

# 1550nm external modulated optical transmitter operating manual



## Table of Contents

Table of Contents.....	- 1 -
1. Overview.....	- 2 -
1.1 About This Manual.....	- 2 -
1.2 Product Description.....	- 2 -
1.3 Features.....	- 2 -
1.4 Block Diagram.....	- 2 -
1.5 Product Applications.....	- 2 -
2. Technique Parameters.....	- 3 -
2.1 Optical Parameters.....	- 3 -
2.2 Model Test Indicators.....	- 3 -
2.3 Test Condition.....	- 3 -
2.4 Technical Data Sheet.....	- 4 -
3. Panel Interface and Menu System Description.....	- 4 -
3.1 Front Panel.....	- 4 -
3.2 Rear Panel.....	- 5 -
3.3 Power Module.....	- 5 -
3.4 Menu Operation.....	- 5 -
4. Installing the WT-1550-EM20 Optical Transmitter.....	- 7 -
4.1 Receiving and Inspecting.....	- 7 -
4.2 Mounting WT-1550-EM20.....	- 7 -
5. Communication Setup.....	- 9 -
5.1 RS232 Communication Interface Description.....	- 9 -
5.2 Set up the Hyper Terminal.....	- 9 -
5.3 Operating Parameters Configuration.....	- 10 -
5.4 Remote Monitoring: SNMP.....	- 12 -
5.5 WEB Network Management.....	- 13 -
6. Maintenance and Troubleshooting.....	- 14 -
6.1 Cleaning Fiber Optic Connectors.....	- 14 -
6.2 Troubleshooting.....	- 15 -
6.3 After-sales Service Description.....	- 16 -
6.4 Disclaimer.....	- 16 -

**Передатчик с длиной волны 1310 и различной оптической мощностью, 1 выход**

Vermax-HL-1310-4	Передатчик оптический Vermax для сетей КТВ HL-1310, 4mW
Vermax-HL-1310-10	Передатчик оптический Vermax для сетей КТВ HL-1310, 10mW
Vermax-HL-1310-12	Передатчик оптический Vermax для сетей КТВ HL-1310, 12mW
Vermax-HL-1310-16	Передатчик оптический Vermax для сетей КТВ HL-1310, 16mW
Vermax-HL-1310-18	Передатчик оптический Vermax для сетей КТВ HL-1310, 18mW
Vermax-HL-1310-20	Передатчик оптический Vermax для сетей КТВ HL-1310, 20mW
Vermax-HL-1310-22	Передатчик оптический Vermax для сетей КТВ HL-1310, 22mW
Vermax-HL-1310-24	Передатчик оптический Vermax для сетей КТВ HL-1310, 24mW
Vermax-HL-1310-26	Передатчик оптический Vermax для сетей КТВ HL-1310, 26mW
Vermax-HL-1310-28	Передатчик оптический Vermax для сетей КТВ HL-1310, 26mW
Vermax-HL-1310-31	Передатчик оптический Vermax для сетей КТВ HL-1310, 31mW

**Передатчик с длиной волны 1550 (цифровая внешняя модуляция) и различной оптической мощностью, 1 выход**

Vermax-HL-1550-1x5	Передатчик оптический для сетей КТВ Vermax-HL-1550-1x5
--------------------	--

Vermax-HL-1550-1x7	Передатчик оптический для сетей КТВ Vermax-HL-1550-1x7
<b>Передатчик с длиной волны 1550 (аналоговая внешняя модуляция) и различной оптической мощностью, 2 выхода</b>	
Vermax-HL-1550CM-2x5	Передатчик оптический для сетей КТВ Vermax-HL-1550CM-2x5
Vermax-HL-1550CM-2x7	Передатчик оптический для сетей КТВ Vermax-HL-1550CM-2x7
Vermax-HL-1550CM-2x7 (DC 48V)	Передатчик оптический для сетей КТВ Vermax-HL-1550CM-2x7 с питанием DC 48 В
Vermax-HL-1550CM-2x7 (AC 220V)	Передатчик оптический для сетей КТВ Vermax-HL-1550CM-2x7 с питанием AC 220 В
Vermax-HL-1550CM-2x7 (AC220 + DC48)	Передатчик оптический для сетей КТВ Vermax-HL-1550CM-2x7 с питанием AC/DC-220/48 В
Vermax-HL-1550CM-2x9	Передатчик оптический для сетей КТВ Vermax-HL-1550CM-2x9
Vermax-HL-1550CM-2x10	Передатчик оптический для сетей КТВ Vermax-HL-1550CM-2x10
Vermax-HL-1550CM-2x10 (DC 48V)	Передатчик оптический для сетей КТВ Vermax-HL-1550CM-2x10 с питанием DC 48 В
Vermax-HL-1550CM-2x10 (AC 220V)	Передатчик оптический для сетей КТВ Vermax-HL-1550CM-2x10 с питанием AC 220 В
Vermax-HL-1550CM-2x10 (AC220+DC48)	Передатчик оптический для сетей КТВ Vermax-HL-1550CM-2x10 с питанием AC/DC-220/48 В
<b>Передатчик с длиной волны 1550 (внешняя модуляция)</b>	
Vermax-HL-D1550-10	Передатчик оптический для сетей КТВ Vermax-HL-D1550-10 с прямой модуляцией
<b>Передатчик с длиной волны 1550 (аналоговая внешняя модуляция)</b>	
Vermax-HL-1550EML	Передатчик оптический для сетей КТВ Vermax-HL-1550EML
<b>Передатчик с длиной волны 1550 (внутренняя модуляция)</b>	
Vermax-HL-1550-DM	Передатчик оптический для сетей КТВ Vermax-HL-1550-DM с прямой модуляцией

# 1. Overview

## 1.1 About This Manual

This instruction manual is guide to install and operate the (1RU) WT-1550-EM20 series 1550nm external modulated optical transmitter. Please read the entire manual before beginning installation.

This manual applies to WT-1550-EM20 series external modulated optical transmitter.

## 1.2 Product Description

WT-1550-EM20 series optical transmitter adopt top-international brand external modulated laser and external modulator, Prevail patent pre-distortion circuit and SBS control circuit. Overall indexes reach to well-known brand types level, and price is inexpensive. We have sold thousands of products over the years. The products save plenty of costs for operator's network construction and get many users' good reputation.

## 1.3 Features

- ◆ This 1550nm optical transmitter can be used in long-distance transmission.
- ◆ Double microwave source SBS control, +13~+19dBm adjustable, 0.5dB step.
- ◆ Adopt the DFB laser and LiNbO3 external modulator.
- ◆ support Ethernet transponder
- ◆ support WEB and SNMP network management.
- ◆ Hot backup dual power modules

## 1.4 Block Diagram

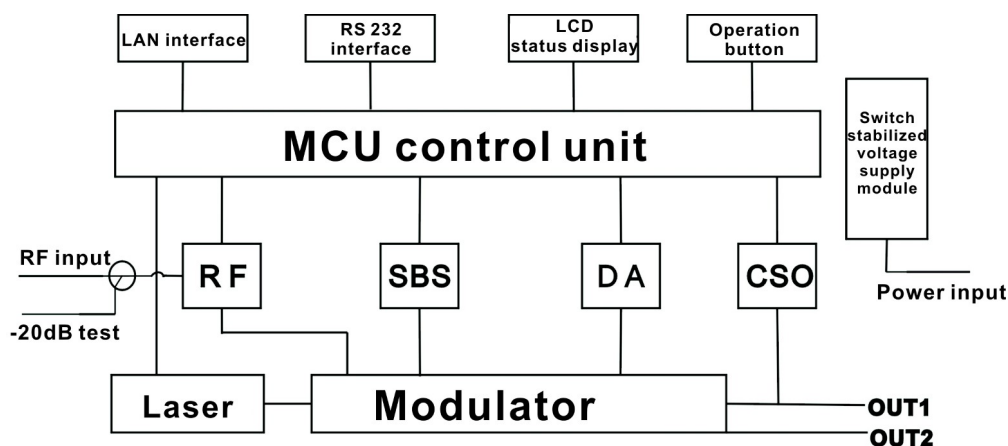

## 1.5 Product Applications

- High-performance long-distance transmission
- High-power distribution network
- Redundancy loop architecture
- FTTx network
- RFOG application
- DWDM network



## 2. Technique Parameters

### 2.1 Optical Parameters

Item	Unit	Value
Optical Wavelength	nm	1545~1560 (or specified by the user)
Side-mode Suppression ratio	dB	>30
Relative Intensity Noise	dB/Hz	<-160
Wavelength Adjustment Range	GHz	+/-50GHz
Optical Power	dBm	2*7, 2*8, 2*9, 2*10
SBS Threshold Value	dBm	+13~+19 (Continuously adjustable)
Laser Linewidth	MHz	0.3

### 2.2 Model Test Indicators

Test Model	C42	D59	D84
Channel Plan	CENELEC42	PAL D59	PAL D84
Channel Number TV/FM/QAM64	42/0/0	59/0/0	84/0/0
Bandwidth Noise	5	5	5
CNR Tx/Rx	55.0	54.0	52.5
CNR Link 1	54.0	53.5	52.0
CNR Link 2	53.0	52.5	50.5
CNR Link 3	50.5	50.5	49.0
CSO Tx/Rx and Link 1	64	64	64
CSO Link 2	63	64	64
CSO Link 3	62	62	62
CTB	62	62	62

### 2.3 Test Condition

	First stage EDFA	First paragraph fiber length	Second stage EDFA	Second paragraph fiber length	RX	SBS (dBm)
Tx/Rx	No	No	No	no	0dBm	13.5
Link 1	No	35km	no	no	0dBm	13.5
Link 2	16dBm	65km	no	no	0dBm	16
Link 3	13dBm	50km	13dBm	50km	0dBm	13.5

## 2.4 Technical Data Sheet

Item	Unit	Technical Parameters
RF range	MHz	47~1003
RF flatness	dB	±0.75
RF return loss	dB	>16
RF input impedance	Ω	75
RF input connector type		F type
Input level range	dBμV	80±5
AGC control range	dB	+3~-3
MGC adjustable range	dB	0~15
Optical connector		SC/APC, FC/APC
Operating temperature	°C	-5~45
Storage temperature	°C	-30~+70
Power Source Specification	V	90~265VAC
		36~72VDC
Consumption	W	≤60
Dimension	mm	483(L) × 455(W) × 44(H)
Total Weight	kg	5.5

## 3. Panel Interface and Menu System Description

### 3.1 Front Panel

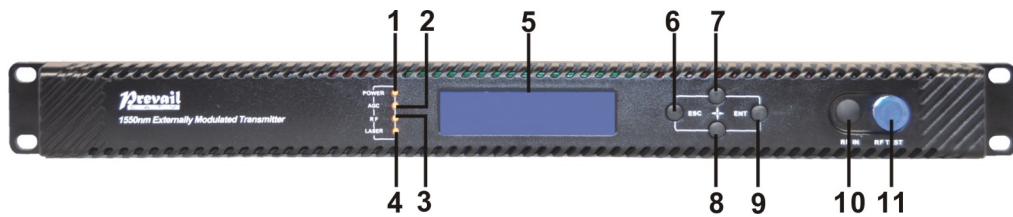

<b>1</b>	Power indicator	<b>2</b>	AGC indicator	<b>3</b>	RF indicator
<b>4</b>	Laser indicator	<b>5</b>	LCD	<b>6</b>	ESC key
<b>7</b>	UP key	<b>8</b>	DOWN key	<b>9</b>	Enter key
<b>10</b>	RF input port (optional)	<b>11</b>	-20dB RF input test port		

#### 3.1.1 Indicator Description

Power indicator	One power supply	LED yellow
	Two power supplies	LED green
AGC indicator	AGC mode	LED green
	MGC mode	LED off
RF indicator	Normal	LED green
	Abnormal	LED flash red
Laser indicator	Bias current, cooling current and output power are all normal	LED green

	At least one of bias current, cooling current and output power is abnormal	LED flash red
--	--	---------------

### 3.2 Rear Panel

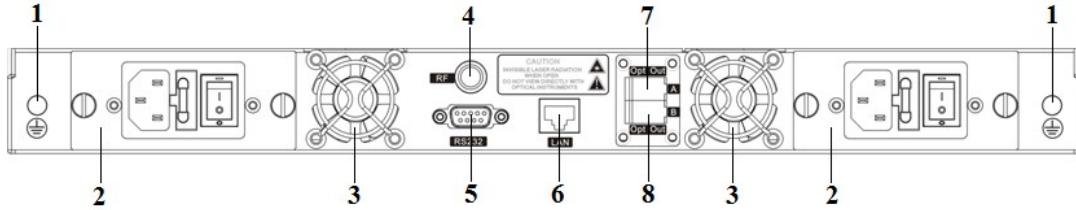

1	Ground stud	2	Power module	3	Fan
4	RF input port (or on the front panel, optional)	5	RS232 interface	6	LAN interface
7	Optical output interface A (or on the front panel, optional)	8	Optical output interface B (or on the front panel, optional)		

### 3.3 Power Module

#### 3.3.1 220V Power Module

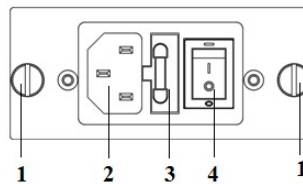

1	Mounting screws	2	220V power outlet	3	Fuse
4	Power switch				

#### 3.3.2 48V Power Module

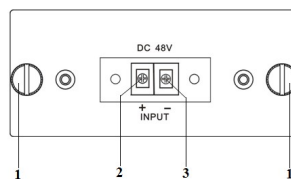

1	Mounting screws	2	+ Positive terminal block	3	- Negative terminal block
---	-----------------	---	---------------------------	---	---------------------------

### 3.4 Menu Operation

#### 3.4.1 Main Menu

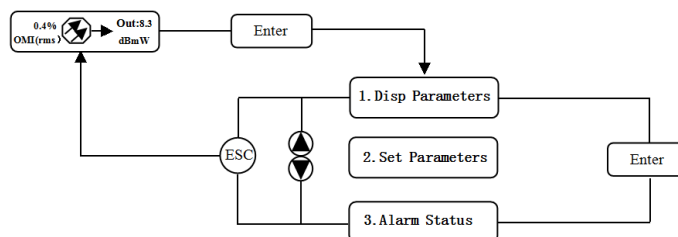

Display	Comments
1. Disp Parameters	Menu one: Display parameters

2.Set Parameters	Menu two: Set parameters
3.Alarm Status	Menu three: Alarm status

### 3.4.2 Display Menu

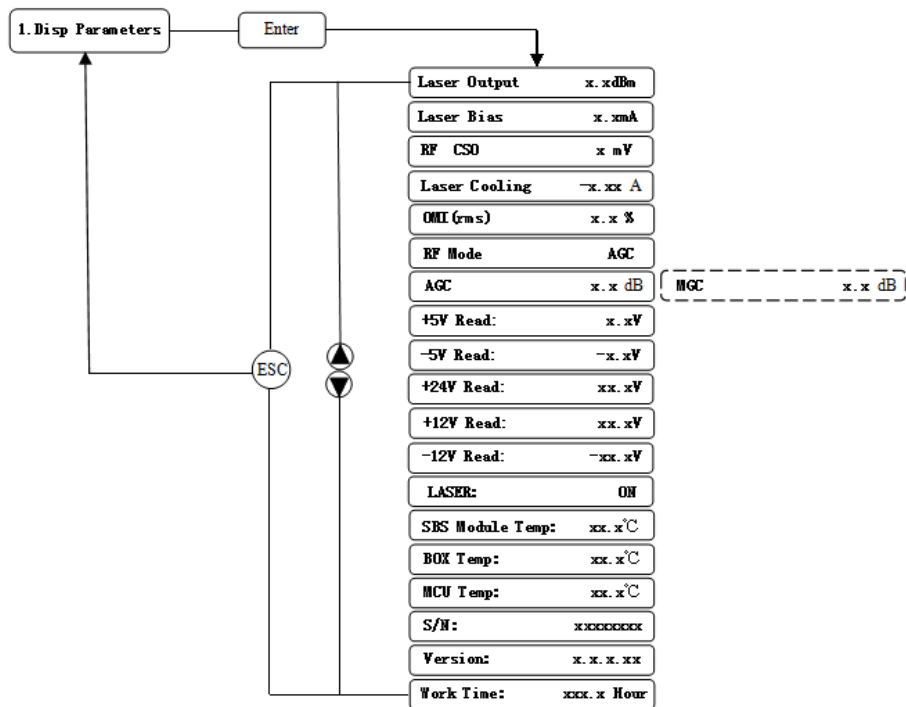

Display	Comments	Display	Comments
Laser Output	Output optical power	+24V Read:	+24V monitor voltage
Laser Bias	Laser current	+12V Read:	+12V monitor voltage
RF CSO	CSO monitor voltage	-12V Read:	-12V monitor voltage
Laser Cooling	Cooling current	LASER:	Laser status
OMI(rms)	Total modulation degree	SBS Module Temp:	SBS module temperature
RF Mode	RF control mode	BOX Temp:	Overall temperature
AGC	Adjusted value with AGC mode	MCU Temp:	MCU temperature
MGC	Adjusted value with MGC mode	S/N:	Serial number
+5V Read:	+5V monitor voltage	Version:	Version number
-5V Read:	-5V monitor voltage	Work Time:	Work time

### 3.4.3 Set Menu

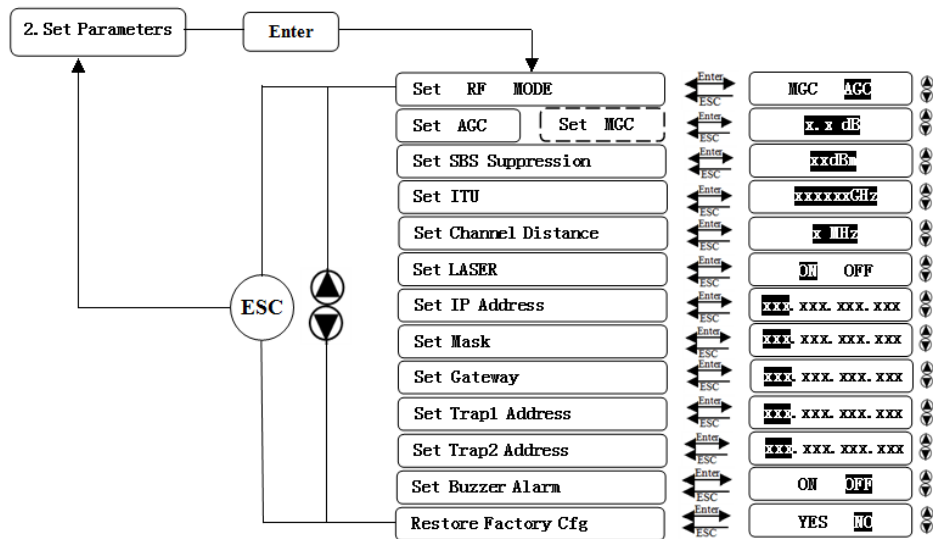

Display	Comments	Remarks
Set RF MODE	Set RF control mode	MGC and AGC two modes selectable
Set AGC   Set MGC	Set RF adjusted value	Adjustable range 0~15dB with MGC mode Adjustable range -3~+3dB with AGC mode
Set SBS Suppression	Set SBS value	Range 13~19dBm, 0.5dB stepping
Set ITU	Set optical wavelength	Range ±50GHz
Set Channel Distance	Set channel distance	6MHz, 7MHz, 8MHz
Set LASER	Set laser status	ON/OFF
Set IP Address	Set IP address	
Set Mask	Set subnet mask	
Set Gateway	Set gateway	
Set Trap1 Address	Set trap1 address	
Set Trap2 Address	Set trap2 address	
Set Buzzer Alarm	Set buzzer alarm	ON/OFF
Restore Factory Cfg	Restore factory settings	

### 3.4.4 Alarm Menu

The displayed alarm content		Comment
RF IN Status	HIGH (LOW)	The RF input signal is high (low)
Laser Bias	HIGH (LOW)	The laser bias current is high (low)
Laser TEC	HIGH	The laser cooling current is high
OutPutPower Status	HIGH (LOW)	The output optical power is high (low)
-5V Status	HIGH (LOW)	The -5V voltage is high (low)
+5V Status	HIGH (LOW)	The +5V voltage is high (low)
+12V Status	HIGH (LOW)	The +12V voltage is high (low)
-12V Status	HIGH (LOW)	The -12V voltage is high (low)
+24V Status	HIGH (LOW)	The +24V voltage is high (low)
Laser	OFF	The laser is off
CSO Initialization failed		The CSO initialization is failed
Power invalid	LEFT (RIGHT)	The left (right) power is invalid

## 4. Installing the WT-1550-EM20 Optical Transmitter

### 4.1 Receiving and Inspecting

As you unpack your unit, inspect the shipping container and equipment for damage. Save the shipping material for future use. If the container or the equipment is damaged, notify both the freight carrier and us.

### 4.2 Mounting WT-1550-EM20

#### 4.2.1 Mounting the EM20 in the Rack

Mounting the EM30 in the standard 19 inch equipment rack:

1. Place the equipment in the rack.
2. Use four screws fixed the mounting lug on the WT-1550-EM20 front panel to the rack.
3. Reliably ground the equipment. The ground terminal is on the rear panel.
4. Visually inspect each key (button) on the front panel to ensure that it is not trapped under the edge of its hole. If a key is trapped, tap the key to enable it to move freely.

#### 4.2.2 Connecting the RF Cables

Verify the RF input F connector type according to the ordering information, then screw on the matched RF cable.

#### 4.2.3 Connecting the Optical Fiber Cables

1. Verify the matched WT-1550-EM20 fiber cable connector type according to the ordering information.
2. Verify that the fiber cable connector has been cleaned properly. If the fiber cable connector needs to be cleaned, follow the cleaning procedure outlined in "Cleaning Patch Cord or Pigtail Fiber Optical Connectors".
3. Verify that the WT-1550-EM20 optical connector has not been exposed to any contamination.

**NOTE:** Any contamination of optical connector can significantly degrade optical link performance. This degradation will most likely manifest itself as poor signal-to-noise (SNR) performance.

4. Note to butt the nick of the connectors and align them accordingly.



#### 4.2.4 Connecting the Ethernet Cable

You can connect the WT-1550-EM20 to your TCP/IP network in order to monitor and control the transmitter remotely. After you complete the installation procedures described in this chapter, you can use a network management system (NMS) to monitor and control the WT-1550-EM20.

To connect the WT-1550-EM20, you must use a shielded and grounded Category 5 Ethernet cable.

To connect the Ethernet cable:

1. Connect an Ethernet cable to the transmitter's RJ-45 Ethernet port and to your TCP/IP network. The Ethernet port is on the built-in transponder of the transmitter.
2. Verify that the green Link LED is illuminated, indicating that there is a connection. The Link LED is above the Ethernet port on the rear panel.

#### 4.2.5 Connecting Power

The WT-1550-EM20 is available in an AC power model or DC power model. After mounting the WT-1550-

EM20 in a rack, follow the power connection procedure below for the model that you are installing.

The AC-powered WT-1550-EM20 has two optional power supplies 110V and 220V:

110V power supply has two 110 VAC (50/60 Hz) input connector that requires input voltage from 90 to 130 VAC, at 50 to 60 Hz single phase. The AC power plug is located on the rear panel.

220V power supply has two 220 VAC (50/60 Hz) input connector that requires input voltage from 150 to 265 VAC, at 50 to 60 Hz single phase. The AC power plug is located on the rear panel.

The DC-powered WT-1550-EM20 has two -48 VDC input connectors that require input voltage from -36 to -72 VDC. The DC input connectors are located on the rear panel.

Turn on the power source. It takes about 60 seconds for all systems to operate. When connect one power supply, the power indicator is yellow; when connect two power supplies, the power indicator is green.

## 5. Communication Setup

### 5.1 RS232 Communication Interface Description

Adopt DB9 standard connector, the pin definitions as follow:

- 1: No Connect
- 2: TX
- 3: RX
- 4: No Connect
- 5: GND
- 6: No Connect
- 7: No Connect
- 8: No Connect
- 9: No Connect

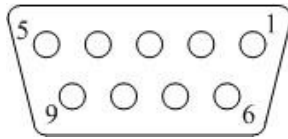

The serial communication uses the standard NRZ form, 1 starts bit, 8 data bits, 1 stop bit and the baud rate is 38400.

### 5.2 Set up the Hyper Terminal

If you have not setup the Hyper Terminal in your Windows system, follow the steps:

Click “start menu → program → accessory → communication → Hyper Terminal”:

This results in the following screen:



Then you input your connection name, such as “SNMP38400”, and choose the serial port to connect with your equipment. As follows:



Press the “OK” button shows the configuration page of serial port. As follows:

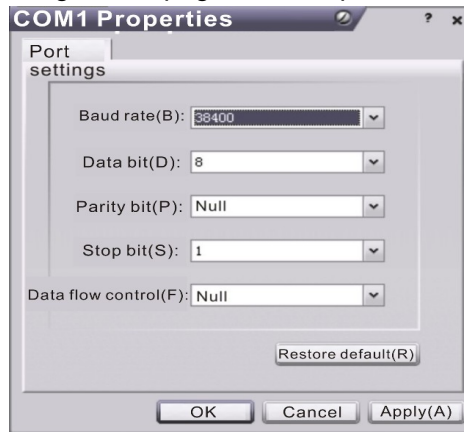

Change the serial port configuration to 38400-baud rate, 8 data bits, no parity bit, 1 stop bit, no data flow control, press the “OK” button, you have set up the Windows serial port Hyper Terminal.

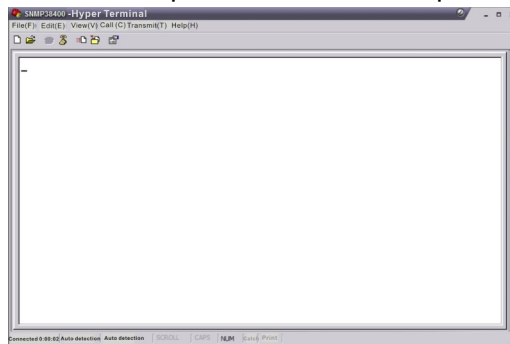

You can click “file→save” menu to save this configuration of Hyper Terminal for later using.

### 5.3 Operating Parameters Configuration

Under the condition of power off, use the serial port lines to connect the RS232 port with the computer port. Open the Windows Hyper Terminal which you have set up. Then turn on the power, you will see the page as follows. Enter the password to enter the configuration interface.

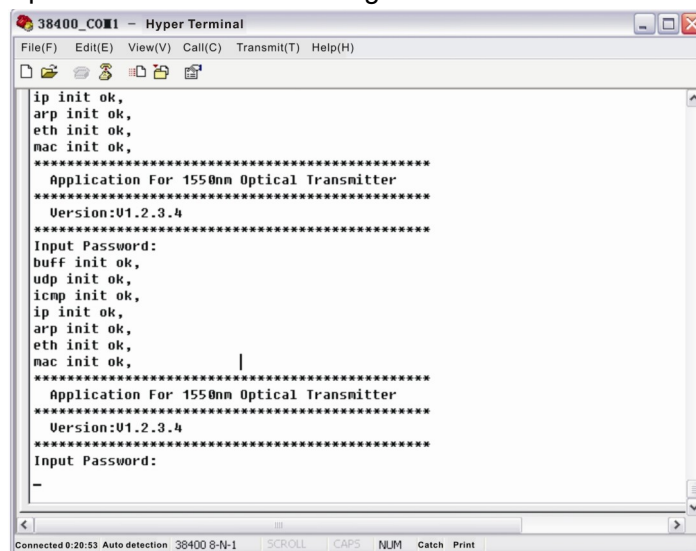

Enter the password, display the following screen:

```

38400_COM1 - Hyper Terminal
File(F) Edit(E) View(V) Call(C) Transmit(T) Help(H)

udp init ok,
icmp init ok,
ip init ok,
arp init ok,
eth init ok,
mac init ok,
mac addr: 00:03:b9:88:10:11
local ip: 192.168.0.251
net mask: 255.255.255.0
gateway : 192.168.0.1
tcpip init ok.
snmp init ok.
gui init ok.

*****
Application For TRANSMITTER SNMP Agent
*****

Version: 3.00
Build time: Jan 12 2007 14:46:35

-----
TRANS:\>

```

You can input your command in this page, and then configure the operating parameter of the application program.

System supports the following commands:

- |                  |  |
|------------------|--|
| <b>help</b>      | List internal commands of the system;                      |
| <b>ethcfg</b>    | Configure the Ethernet operating parameters;               |
| <b>settrap</b>   | Configure the aim host IP address of the SNMP Trap;        |
| <b>community</b> | Configure the SNMP group name;                             |
| <b>List</b>      | List system default parameters or user updated parameters; |
| <b>Restore</b>   | Restore the factory default values;                        |

**Specific using as follows :**

**help**

This command shows current application program version, program name and the internal commands list of the system as follows:

```

38400_COM1 - Hyper Terminal
File(F) Edit(E) View(V) Call(C) Transmit(T) Help(H)

*****
Input Password:
*****
Login Successfull.
Transmitter\>help
NAME
    help - help
SYNOPSIS
    help [command]
DESCRIPTION
    help - show help summary and command help.
OPTIONS
    1) help call help menu/command's help.
    2) entplogo show/set enterprise logo.
    3) ethcfg ethernet module config.
    4) settrap show/set trap address.
    5) list list default/current setting
    6) restore restore to factory default settings.
    7) setpassword reset password
    8) community show/set snmp community string
    9) exit logout
Transmitter\>

```

You can also use the “help” command to show help information of other commands, such as “help ethcfg”, ethcfg’s help information appears as follows:

```

38400_COM1 - Hyper Terminal
File(F) Edit(E) View(V) Call(C) Transmit(T) Help(H)
1) help call help menu/command's help.
2) entplogo show/set enterprise logo.
3) ethcfg ethernet module config.
4) settrap show/set trap address.
5) list list default/current setting
6) restore restore to factory default settings.
7) setpassword reset password
8) community show/set snmp community string
9) exit logout
Tansmitter\>help ethcfg
NAME
ethcfg ethernet module config.
SYNOPSIS
ethcfg [option] [logo]
DESCRIPTION
Only numbers and letters accepted in [logo],with MAXLENGTH 20.
OPTIONS
ip - set ip address.
msk - set subnet mask.
gw - set gateway.
Tansmitter\>_

```

### ethcfg

This command configures the Ethernet parameters, including IP address, subnet mask and gateway. You can refer to the help information for its using.

### settrap

This command shows or modifies the aim host IP address list of the SNMP Trap, IP address of 0.0.0.0 and 255.255.255.255 don't exist. SNMP Trap does not send to these two addresses.

### community

This command configures the read-only group name and read-write group name. "Group name" is the concept of SNMP agreement like the password. Use the command "community ro" to configure the read-only, and "community rw" for the read-write. For example, input "community rw public", "public" is the read-write group name. The group name for read-only and read-write are both "public" as the equipment default setting from factory.

## 5.4 Remote Monitoring: SNMP

LAN communication interface

Adopt RJ45 standard connector, the pin definitions as follow:

- 1: TX+
- 2: TX-
- 3: RX+
- 4: No Connect
- 5: No Connect
- 6: RX-
- 7: No Connect
- 8: No Connect

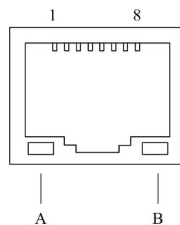

- A: Green indicator flashing means that the LAN port is sending data.
- B: Yellow indicator means that the network connection is normal.

### SNMP basic background

Simple Network Management Protocol (SNMP) is an application layer protocol. It makes the management information between network devices exchange easier. It is part of the TCP / IP protocol group. SNMP enables the end-users to manage network performance, find and solve network problems, and arrange for

future network upgrades.

Management Information Base (MIB) is the organized hierarchical information set. Use SNMP to visit these MIB. They are composed of manageable information, and identified by the object identifier.

## SNMP

Transmitter configuration of network communication

When the transmitter initial work, the IP address and gateway are in the default state, you need to configure them. The configuration of initial state can be achieved through the RS-232 interface or the front panel keys. Other configurations see our **5.5 WEB Network Management** section.

## 5.5 WEB Network Management

Open the IE browser, type the IP address and enter the interface as follows:

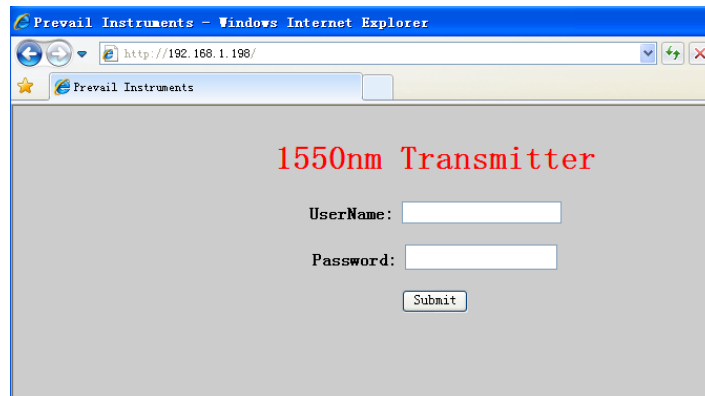

Type the user name **admin** and the password **123456** (factory default), enter the following interface:

### *1550nm External Modulation Optical Transmitter*

- [About 1550](#)
- [Disp Paraments](#)
- [Set Paraments](#)

#### Product brief introduction

1550nm External Modulation Optical Transmitter of WT 1550A series are mainly used for long-distance optical fiber transmission of television image signal, digital TV signal and data signal. In the part of optical circuit, adopt famous brand 1550nm DFB laser and LiNbO3 external modulator. In the part of RF driving, adopt double microwave sources SBS control technology that researched and developed by us independently and advanced RF pre-distortion circuit. Microcomputer automatic control system is built in it to make sure the excellent performance.

#### Performance characteristics

Optimized controlling, get better CNR, CTB, CSO and SBS.

SBS threshold 13-19 adjustable, suitable for different networks.

Use low noise, narrow-band, continuous wave laser as optical source. Varies output level, suitable for different networks.

Chassis temperature automatic monitoring.

Advanced internet management function.

There are 3 sub-interfaces:

1. **About1550** interface: Mainly described the basic information of the equipment.
2. **Disp Paraments** interface: Mainly described the display menu of the equipment.
3. **Set Paraments** interface: Change the device parameters in this interface.

Click **Set Parameters** to enter **Set Parameters** interface as follows:

*1550nm External Modulated Optical Transmitter*

- About 1550
- Diap Parameters
- **Set Parameters**
- Modify Password

**Set Parameter**

---

Module Parameter

Item	Current	New	Update
Channel Distance	8 MHz	6 ▾ MHz	<input type="button" value="Update"/>
RF MODE	AGC	MGC ▾	<input type="button" value="Update"/>
AGC Ref	0.0 dB	-3 ▾ dB	<input type="button" value="Update"/>
MGC Ref	6.0 dB	0 ▾ dB	<input type="button" value="Update"/>
Laser Control	ON	OFF ▾	<input type="button" value="Update"/>
SET ITU	192400 GHz	-50 ▾	<input type="button" value="Update"/>
SET SBS	16.0 dBm	13 ▾	<input type="button" value="Update"/>

IP Address Set

Item	Current	New	Update
Static IP Address	192.168.1.198	<input type="text"/> . <input type="text"/> . <input type="text"/> . <input type="text"/>	<input type="button" value="Update"/>
Subnet Mask	255.255.255.0	<input type="text"/> . <input type="text"/> . <input type="text"/> . <input type="text"/>	<input type="button" value="Update"/>
Default Gateway	192.168.1.1	<input type="text"/> . <input type="text"/> . <input type="text"/> . <input type="text"/>	<input type="button" value="Update"/>
Trap Address1	192.168.14.188	<input type="text"/> . <input type="text"/> . <input type="text"/> . <input type="text"/>	<input type="button" value="Update"/>
Trap Address2	192.168.1.25	<input type="text"/> . <input type="text"/> . <input type="text"/> . <input type="text"/>	<input type="button" value="Update"/>

The Item and Items columns list the parameters that can be changed, the Current column lists the present parameter values, the New column can select or type the new parameter values, and the Update column can update the parameters.

The steps to change the parameters: find the item in the Item column, select the new parameter values in the New column, and click the corresponding Update button to update the parameters.

The change steps in the Items are the same, but finally need to click the Restart Device button to take effect.

## 6. Maintenance and Troubleshooting

### 6.1 Cleaning Fiber Optic Connectors

Dirty optical connectors are the leading source of poor performance in a broadband optical fiber network. Dirty optical connectors lead to optical signal loss and reflections, which in turn can seriously degrade signal-to-noise (SNR) performance and, in some cases, distortion performance. We recommend that you clean all mating fiber connectors before connecting them to an optical transmitter.

In addition, if you suspect that the optical connector of WT-1550-EM20 may have been exposed to contamination (by a dirty fiber cable connector, for example), you should properly clean the WT-1550-EM20 optical connector before connecting the optical fiber.

#### 6.1.1 Cleaning Patch Cord or Pigtail Fiber Optical Connectors

To clean optical connectors, we recommend using a fiber optic connector cleaning cartridge (such as NTT Cletop). If a cleaning cartridge is not available, follow these steps.

To clean the optical connector of a patch cord or pigtail:

1. Fold a piece of unused dry lens cleaning paper twice, for a four-ply thickness.
2. Use a drop of high-grade isopropyl alcohol to wet part of the paper.
3. Lay the connector on the lens cleaning paper with the tip touching the paper.
4. In one continuous motion, pull the connector from the wet part of the paper to the dry part.

## 6.2 Troubleshooting

Should a problem occur, see if the symptoms are listed in Table 6-1.

Table 6-1: Troubleshooting Solutions

Indicator status	Alarm menu content	Fault phenomenon	Solution
Power indicator is yellow	Power Invalid LEFT (RIGHT)	The left (right) power is break down or the power cord is not plugged in	Plug in the left (right) power cord. If that does not correct the problem, contact Customer Service. Replace the power supply.
Power indicator is flash yellow	-5V Status HIGH (LOW) +5V Status HIGH (LOW) +12V Status HIGH (LOW) -12V Status HIGH (LOW) +24V Status HIGH (LOW)	Power alarm menu shows one of the contents The laser is off	Contact Customer Service.
RF indicator is flash red	RF IN Status LOW (HIGH)	RF input is low (high)	Verify the optical transmitter is operating within the proper input level threshold range, If that does not solve the problem, contact Customer Service.
	CSO Initialization failed	CSO nonlinearity indexes are poor	Disconnect the RF connection, wait 10 seconds before reconnecting the RF signal.
Laser indicator is flash red	Laser Bias HIGH	The laser is off	Contact Customer Service.
	Laser TEC HIGH	The laser is off	Verify that the unit is operating within the proper temperature range (-5 ~ +45°C). Verify that nothing is obstructing airflow through the openings in the front and back of the unit. Recall factory settings by pressing the key on the front panel (see Section 3). If that does not correct the problem, contact Customer Service.
	OutPutPower Status HIGH (LOW)	The laser is off	Reboot the equipment. If that does not correct the problem, contact Customer Service.
None	None	The optical output power is lower than the nominal value	Check the fiber connector. Follow the connector cleaning procedure (see Section 6.1). If that does not correct the problem, contact Customer Service.

### **6.3 After-sales Service Description**

If the equipment fault is resulted from the users' improperly operation or unavoidable environment reasons, we will responsible maintenance but ask suitable material cost.

When the equipment breaks down, immediately contact local distributor or directly call our technical support hotline 86-0571-82576002, 18967160936.

The site maintenance of the fault equipment must be operated by professional technicians to avoid worse damage.

Special notice: If the equipment has been maintained by users, we will not responsible free maintenance. We will ask suitable maintenance cost and material cost.

### **6.4 Disclaimer**

We reserve the right to change any products described herein at any time, and without prior notice. We assume no responsibility or liability arising from the use of the products described herein, except as expressly agreed to in writing by us. The use and purchase of this product does not convey a license under any patent rights, copyrights, trademark rights, or any intellectual property rights of us. Nothing hereunder constitutes a representation or warranty that using any products in the manner described herein will not infringe any patents of third parties.