

RPDU (Ruggedized Power Distribution Unit) User Manual

Contents

1. RPDU Introduction.....	3
1.1. Function Description.....	3
1.2 Application range.....	4
1.3 Product picture and description.....	5
1.4 Installation.....	6
2. Hardware Introduction.....	6
2.1. System initialization.....	6
2.2. View system information.....	7
2.3.Overload Monitoring.....	10
2.4. Environment monitoring.....	10
2.5. RPDU reset.....	11
2.6. Display backlight always-on configuration.....	11
2.7. Reverse the display.....	11
2.8. Restore to factory settings.....	11
2.9. Master or Slave configuration.....	11
2.10. Daisy-Chain.....	11
3. RPDU Software Introduction.....	12
3.1. Software overview.....	12
3.2. Access method.....	12
3.2.1 Web access.....	12
3.2.2 SNMP Access.....	36
3.2.3 Telnet Access.....	46
3.2.3 “STATUS” command.....	47
3.2.4 “ON/OFF” command.....	50
3.2.5 Set command:.....	51
4. Frequently Asked Questions.....	55
4.1. Forget IP address?.....	55
4.2. Fail to send email?.....	55
4.3. Lost IP?	55
5. Technology Parameters.....	55
6. Warranty and Service.....	57

1. RPDU Introduction

The RPDU(Ruggedized Power Distribution Unit) is a network manageable device that provides power monitoring, controlling and managements to many equipments in the rack cabinet of data center all over the world through LAN or WAN. For meeting with the restrictions and requirements in different environment, RPDU supplies many connection methods that user can manage it through its Web interface(HTTP or HTTPS), Serial connection, Telnet or SNMP.

1.1. Function Description

1. Monitoring function: monitor the current, voltage, power (kW) and energy consumption (kWh), environment status like temperature, humidity, smoke, door and water leakage via IP and local LCD screen.
2. Controlling function: switch on/off individual outlet, set the interval of sequential power on/off
3. Keeping the former state: keep the former state of each outlet after resetting.
4. User-defined alarm: use can set the threshold of current, temperature and humidity.
5. System default alarm: receive warning when the total rating current,individual rating current(A&C series not included) are exceeded; when smoke, water or door open was detected
6. Alarm methods: Alarming information will be shown on LCD screen and RPDU buzzer beeps, the problem value flashes on web interface and PC buzzer alarms, automatically send e-mail to system administrator, SNMP sends Trap alerts.
7. Daisy-chain: suggest daisy-chain at most 5 units (Master unit included)
8. User management: user rights configurable. Added new user can be distributed into different user groups with different rights. User group rights are editable.
9. Access method: Web interface, HTTP, HTTPS, SNMP (v1 / v2c / v3), Telnet and Serial console.
10. Support multi-user operation system and software update.

A. B. C. D function comparison table:

SN.	Function	Description & Range
1	Monitoring	Monitoring function: Through the local LCD screen user can view the total current and the current of each individual outlet(A&C series not included), the on/off status of each individual outlet(A&B series not included), the environment status like temperature/humidity/smoke/water logging and door
2	Controlling	Controlling function(A&B series not included): Switching On/Off each individual outlet, set up the power on/off delay, Return-to-zero for total or individual power consumption, configure the schedule event, power cut-off settings when overload, quick setup of mass PDUs and back-up, WIFI settings.
3	Keeping the former state	Keeping the former status (A&B series not included) :keep the former state of each outlet after restart
4	User-defined alarm	User-defined alarm: when thresholds of total current, individual current(A&C series not included), temperature and humidity are exceeded
5	System default alarm	System default alarm: when the total rating current,individual rating current(A&C series not included) are exceeded; when smoke, water or door open was detected

1.2 Application range

1. RPDU can be applied to server rack, network cabinet and etc.
2. Outlet type and number (8, 16, 24) can be selected according to the actual needs.
3. Meets RoHS directive, applicable for 110~220VAC, 380VAC power supply, can meet customers' requirements all over the world.

1.3 Product picture and description

1.3.1 Vertical RPDU(0U)

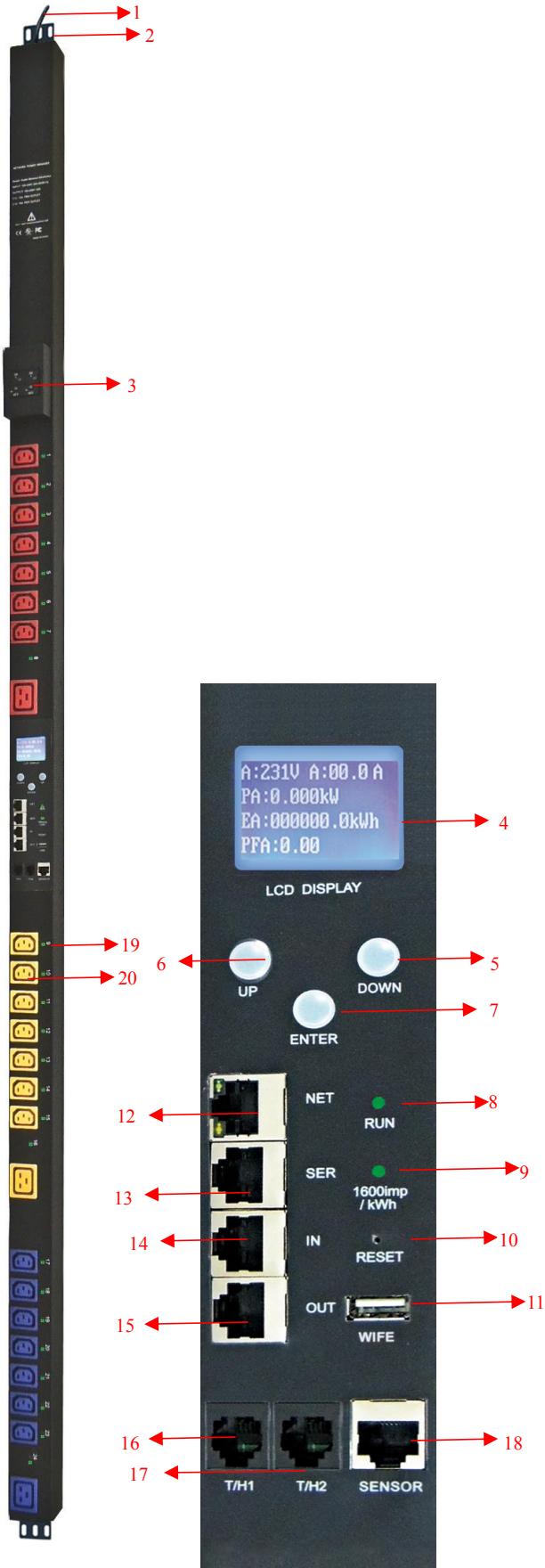

1. Input power cord;
2. Brackets;
3. Hydraulic circuit breaker;
4. LCD screen;
5. DOWN key: scroll down to the next page;
6. UP key: scroll up to the previous page;
7. ENTER: OK button;
8. RUN indicator
9. 1600imp/kWh Energy pulse indicator;
10. RESET button;
11. USB port for WIFI access or software upgrade;
12. NET: 10/100M Ethernet communication port
13. SER: Serial communication port(support MODBUS) ;
14. IN: for daisy-chain
15. OUT: for daisy-chain
16. T/H1: temperature and humidity sensor port 1
17. T/H1: temperature and humidity sensor port 2
18. SENSOR: extend sensor hub communication port, sensor hub support 2 temperature/humidity sensor, 2 door sensor, 1 water logging sensor and 1 smoke sensor
19. LED indicator;
20. Outlets

1.3.2 Horizontal RPDU(1U)

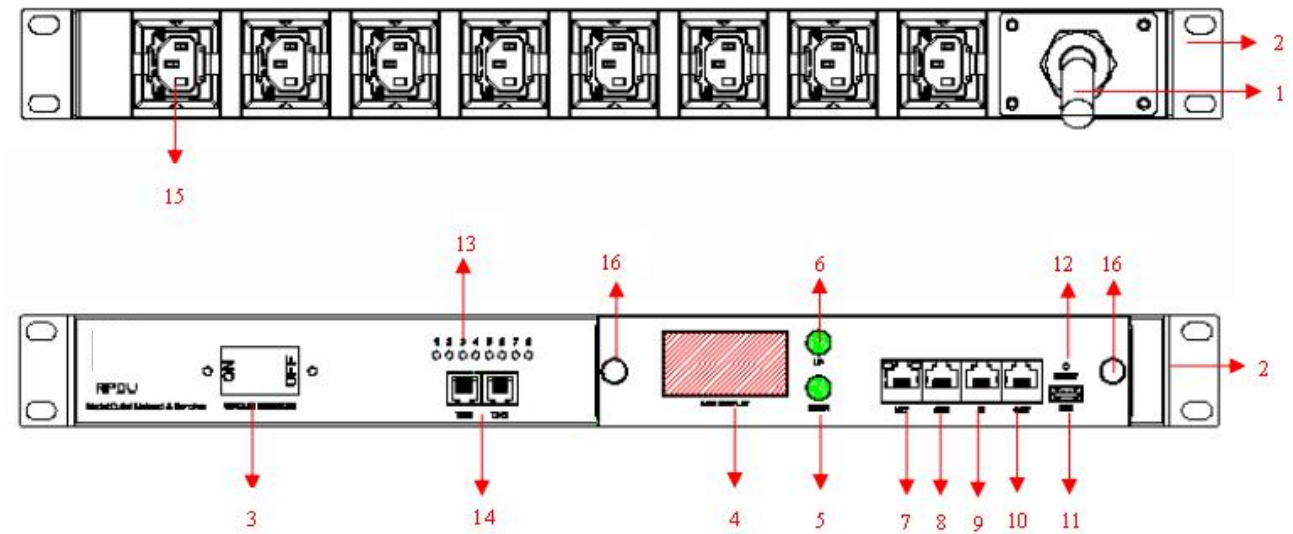

1. Input power cord;
2. Brackets;
3. Hydraulic circuit breaker;
4. LCD screen;
5. DOWN key: scroll down to the next page;
6. UP key: scroll up to the previous page;
- 7.NET: 10/100M Ethernet communication port
8. SER: Serial communication port(support MODBUS) ;
9. IN: for daisy-chain
10. OUT: for daisy-chain
- 11.USB port for WIFI access or software upgrade;
12. RESET button;
13. LED indicator;
- 14.T/H1 T/H2: temperature and humidity sensor port;
- 15.Outlets
- 16.Fixed screw

1.4 Installation

Vertical-mounting (0U)、Horizontal-mounting (1U)

2. Hardware Introduction

2.1. System initialization

The buzzer sounds when the RPDU is switched on and the it stops after 3 seconds. Then the LCD screen is lighted after 6 seconds with the following information displayed:

15:53:58 2015-04-21 192.168.1.163	(Device time) (Date) (IP address)	15:53:58 2015-04-21	(Device time) (Date)
Vertical (0U)		Horizontal (1U)	

Note: 192.168.1.163 is the default IP address; And this is the first page after system initialization.

2.2. View system information

2.2.1. View system information (0U)

Press **ENTER** to go to the main menu

(the first page on menu)

Information Total Tem/Hum Sensors	(Device information) (Total power data) (Temperature/Humidity) (Door/water logging/smoke)
--	--

(The second page on menu)

Output Group	(Outlet socket) (Outlet group)
-----------------	-----------------------------------

Through the DOWN or UP key to scroll down or up to the next/previous page, turn to the main menu and select the first item **Information**, then press **ENTER** to go to the Information menu and the displayed information are as below:

CPU:ARM926EJ-S Verison:1.0.0 M/S:Master Type:3 phase D	(CPU model) (Software version) (Master/Slave unit) (Device series)
---	---

Note: the displayed information may differ from device part number. CPU: ARM926EJ-S means the type of the device CPU chip; Version: 1.0.0 is the software version number; M/S: Master means the Master Unit and Slave 1 means the Slave unit 1(1-4 means the order of Slave unit); Type: 3 phase C means the device is 3 phase C series one.

Through the DOWN or UP key to scroll down or up to the next/previous page, turn to the main menu and select the second item **Total**, then press ENTER to go to the Total menu and the displayed information are as below:

```

U:214V  I:00.0A
P:0.000kW
E:000013.1kWh
PF:0.00
    
```

Note: the above information is from a single phase device, if it is a 3 phase one, the power date of each phase will be displayed as well. U:214V means the input voltage, I:00.0A means the total input current, P:0.000KW means the total power, E:000013.1kWh means the total power consumption, PF:0.00 means the power factor

Press **ENTER** to return to the main menu, then press **DOWN** key to select **Temp/Hum** to view the temperature/humidity as below:

```

T1: ---  H1: ---
T2: ---  H2: ---
T3: ---  H3: ---
T4: ---  H4 :---
    
```

Press **ENTER** to return to the main menu, then press **DOWN** key to select **Sensors** to view the door, water logging, smoke sensor status as below:

```

Door1:None
Door2:None
Smoke:None
Water:None
    
```

Press **ENTER** to return to the main menu, then press **DOWN** key to select **Output** to view each individual outlet current as below:

Output01:00.0A
Output02:00.0A
Output03:00.0A
Output04:00.0A

Press **DOWN** or **UP** key to view the current of rest outputs:

Note: Press **UP** button to view the previous page of device information.

Press **ENTER** to return to the main menu, then press **DOWN** key to select **Group** to view each group outlet current as below:

Group1:00.0A	Group5:00.0A
Group2:00.0A	Group6:00.0A
Group3:00.0A	
Group4:00.0A	

2.2.2. View system information (1U)

Through the **DOWN** or **UP** key to scroll down or up to the next/previous page, turn to the main menu and select the first item **Information**, then press **ENTER** to go to the Information menu and the displayed information are as below:

Type: RPDU(D)	(Device series)
192.168.1.163	(IP address)
Verison:1.0.0	(Software version)
M/S:Master	(Master/Slave unit)

Note: the displayed information may differ from device part number. Type: RPDU(D) means the device is Dseries ; 192.168.1.163 is the IP address, Version: 1.0.0 is the software version number; M/S: Master means the Master Unit and Slave 1 means the Slave unit 1(1-4 means the order of Slave unit);

Through the **DOWN** or **UP** key to scroll down or up to the next/previous page, turn to the main menu and select the second item **Total**, then press **DOWM** to go to the Total menu and the displayed information are as below:

```

U:214V  I:00.0A

P:0.000kW

E:000013.1kWh

PF:0.00
    
```

Note: the above information is from a single phase device, if it is a 3 phase one, the power date of each phase will be displayed as well. U:214V means the input voltage, I:00.0A means the total input current, P:0.000KW means the total power, E:000013.1kWh means the total power consumption, PF:0.00 means the power factor

Press **DOWN** key to select **Temp/Hum** to view the temperature/humidity as below:

```

T1: ---  H1: ---

T2: ---  H2: ---

T3: ---  H3: ---

T4: ---  H4 :---
    
```

Press **DOWN** key to select **Output** to view each individual outlet current as below:

Output1:00.0A	Output5:00.0A
Output2:00.0A	Output6:00.0A
Output3:00.0A	Output7:00.0A
Output4:00.0A	Output8:00.0A

Note: Press UP button to view the previous page of device information.

2.3.Overload Monitoring

2.3.1. When the current of individual outlet exceed the user-defined value, the RPDU buzzer sounds; LCD screen will light up and switch automatically to the alarming page and current value flash

2.3.2. When the total current exceed the user-defined value, the RPDU buzzer sounds; LCD screen will light up and switch automatically to the alarming page and current value flash

2.4. Environment monitoring

When threshold of temperature or humidity is exceeded, the RPDU buzzer sounds, LCD screen light up and switch automatically to the alarming page. The current temperature or humidity value flashes.

2.5. PDU reset

Press and hold the UP key for 6 second to Reset

Note: The configuration of the power on/off delay was required again after reset.

2.6. Display backlight always-on configuration

Press and hold the DOWN key around 2 seconds, the buzzer sounds and the display screen always light on, Press and hold the DOWN key for another 2 seconds, the display screen will back to normal mode

2.7. Reverse the display

Press UP button twice quickly to reverse the text displayed. (Horizontal no rollover function.)

2.8. Restore to factory settings

Press and hold the Reset button for 6 seconds and release it till the beep buzzer to restore to factory settings.

2.9. Master or Slave configuration

To configure the the RPDU to be the Master or Slave in the Web interface. The current Master or Slave status will be displayed in the LCD home page, “M/S: Master” means Master, and “M/S:Slave1” means Slave 1

2.10. Daisy-Chain

Daisy-chain schema is as following:

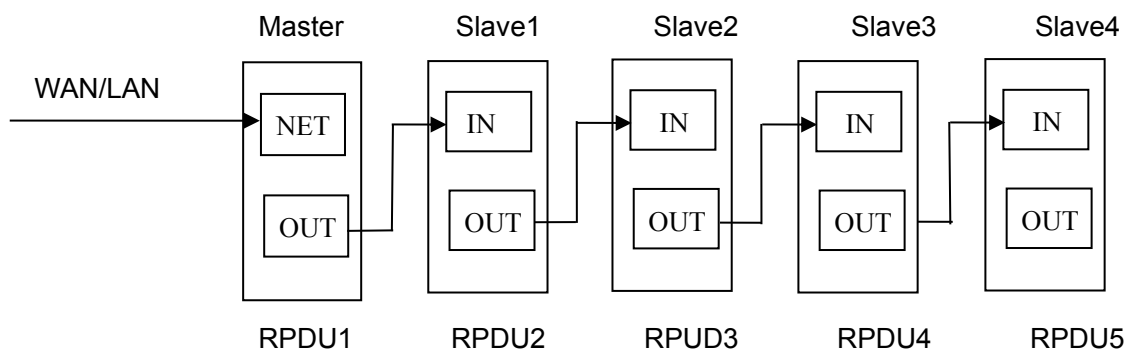

How to daisy-chain

2.10.1. Log on to each RPDU, configure the [work mode](#) on [Device Manage](#) page.

2.10.2. Daisy-chain all devices like above drawing, from OUT to IN, Maximum 5 units including Master.

2.10.3. Access the Master and check all the status of Slaves. If all readable, daisy-chain is successful.

Remark:

1. Once system runs normal, about 10s later LCD screen display normal.
2. Device sequential power on, power off interval time about 30s. Do not power on/off device frequently to avoid device damage.

3. RPDU Software Introduction

3.1. Software overview

RPDU is equipped with embedded software system which provides a lot of network services like WEB server, SNMP, Telnet, SMTP and NTP. It's easy to do second development and software integration.

3.2. Access method

Web based, can access via browsers like Internet Explorer, Google Chrome and Fire fox; supports WIFI (including the mobile device like smart phone and tablet), SNMP (v1 / v2c / v3), Telnet and Serial console like MODBUS.

3.2.1 Web access

Open a browser and enter the default IP address, the login window will pop up like below, See figure 1-1.

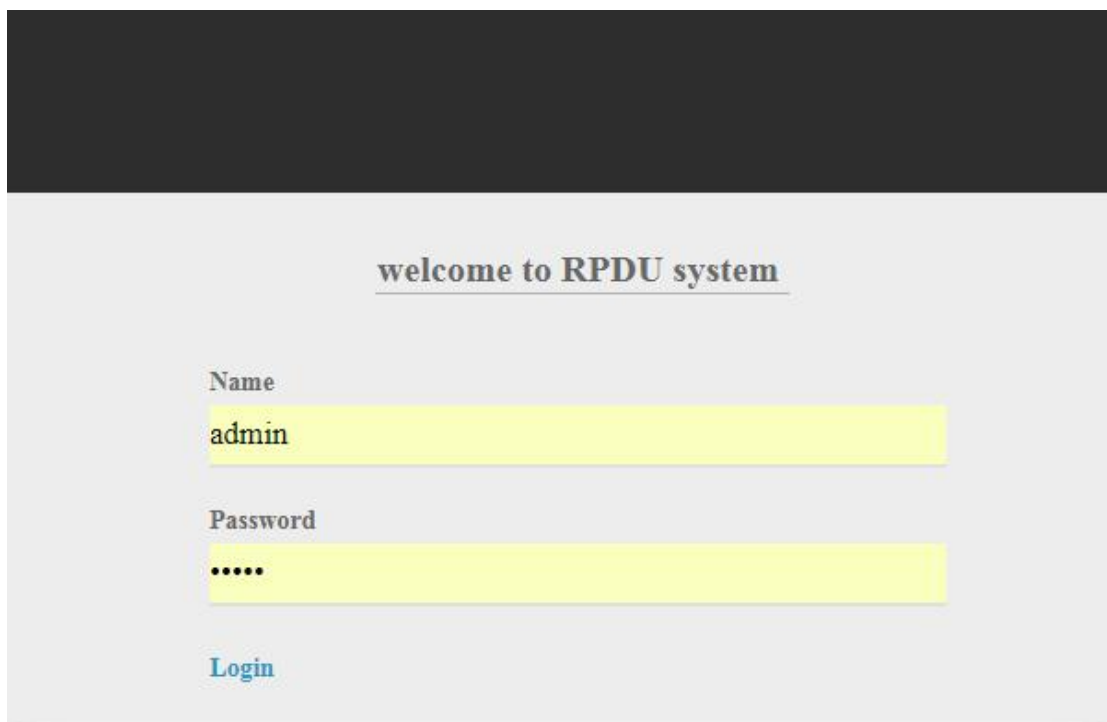

Figure 1-1

Fill in the correct user name and password (Factory default login name is admin, password is admin) to login the main interface . See figure1-2

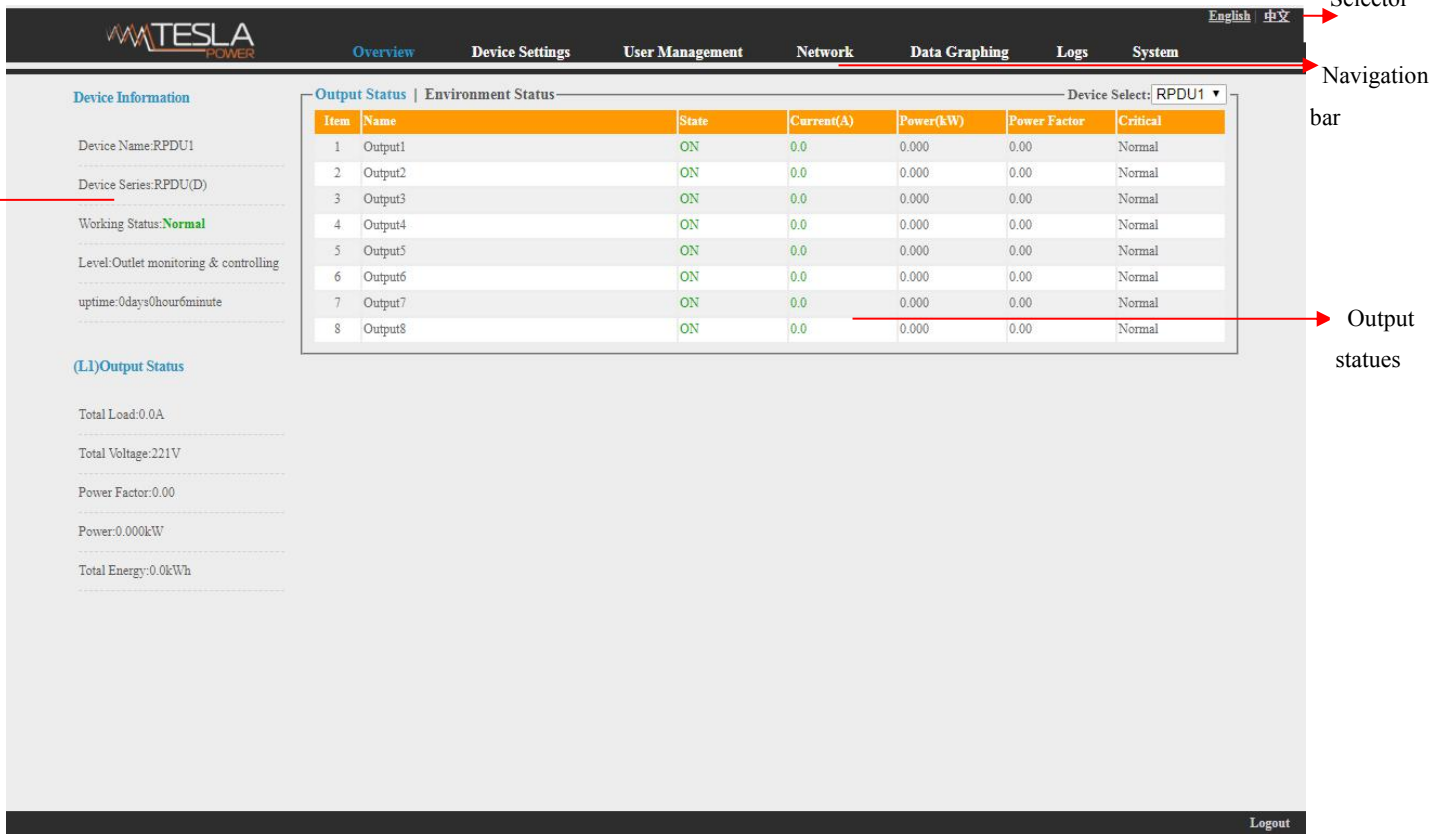

Figure 1-2

Mainly 3 parts on main interface: Navigation menu, Device information and Output status.

Navigation menu: show company logo and function menus and language selector.

Device information: display device name, device series, device status and function level.

Output status: display output name, on/off state, individual current, individual power, power factor and environment status. From the drop down menu of device to check the information of Slaves.

3.2.1.1 Device information

Device information includes device name, device series, device status and function level. Output status includes total load, voltage, power factor, total power (kW) and total energy consumption (kWh).

3.2.1.2. Device Management: Click Device Management from menu to do basic configuration of the device like Figure 1-3

A. Basic settings

- a. **Work mode setting:** set the device as Master or Slave (1-4) from the drop down menu and save.
- b. **Device name setting:** re-name the devices and save.
- c. **Unitive Power delay:** enable or disable the unitive power delay, when enable the unitive power delay, the outlet will power on or off sequentially according to the unitive interval (range from 0 to 15) set.

When the unitive power on/off delay was disabled, the output will power on/off sequentially according to the individual internal, please refer to the outlet settings function on page 12(Figure 1-3-2)

- d. **Mode setting:** configure the buzzer status, enable or disable the group outlet, enable or disable the LCD screen always light on

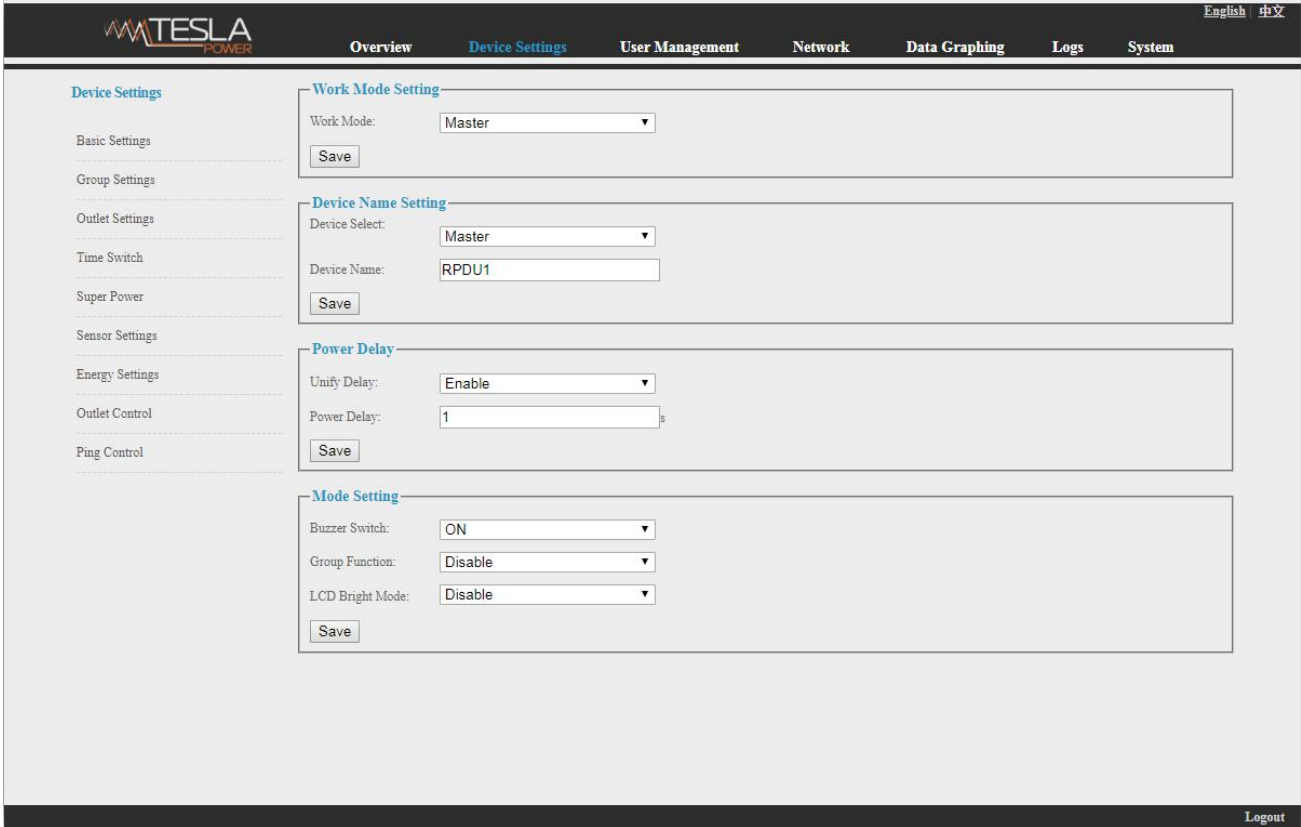

Figure 1-3

B. Group outlet setting: when enabled the group outlet from the basic settings, user can tick off any outlet to 6 different groups randomly, save the operation after configuration

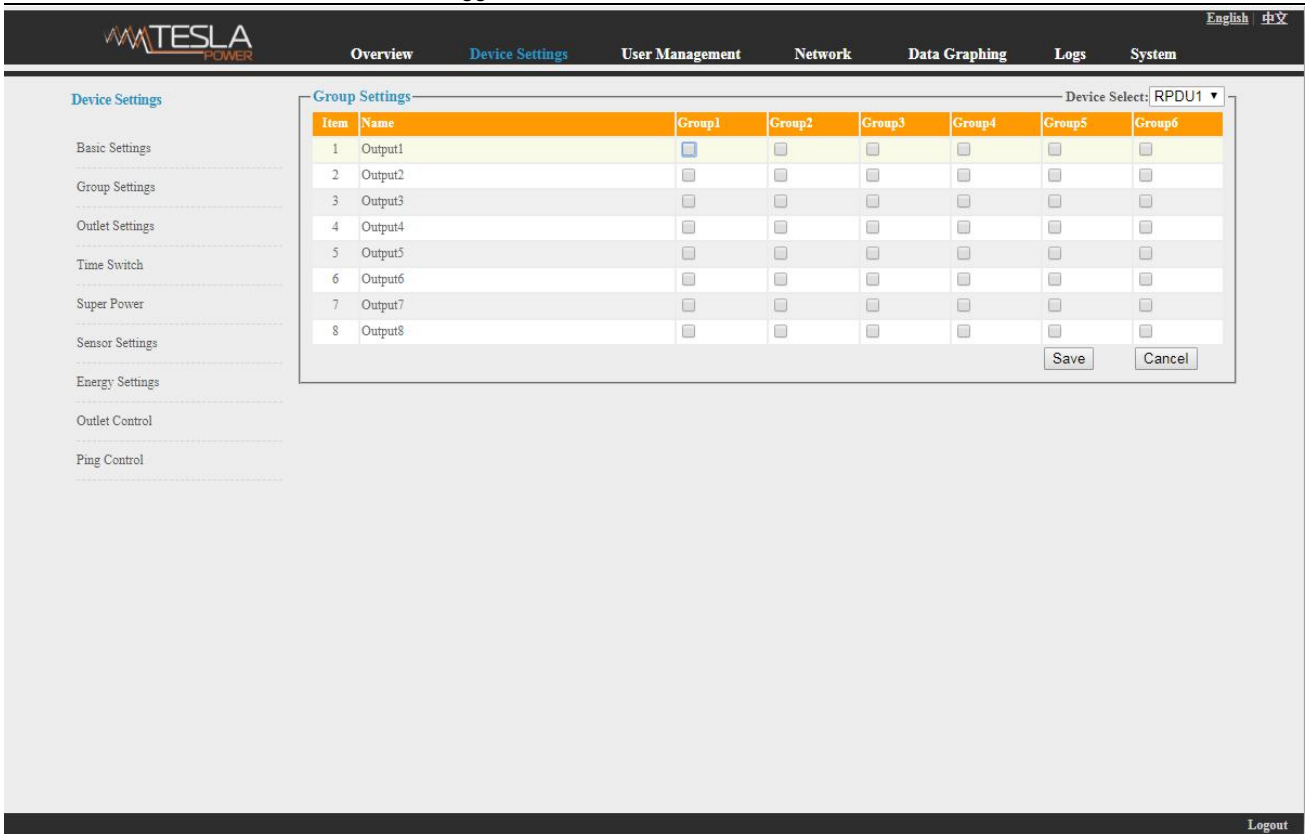

Figure1-3-1

C. Outlet settings: Click [Outlet setting](#) from [Device management](#) to enter the following figure 1-3-2

- a. Outlet name: To rename each individual outlet and click save to complete
- b. The threshold of individual outlet setting: enter the user-defined threshold to alarm
- c. The near threshold of individual outlet setting: configure the near overload warning value for individual outlet
- d. Individual power delay setting: when the unitive power delay was disabled, the output will power on/off sequentially according to the individual interval (range from 0 to 15 seconds)set by user

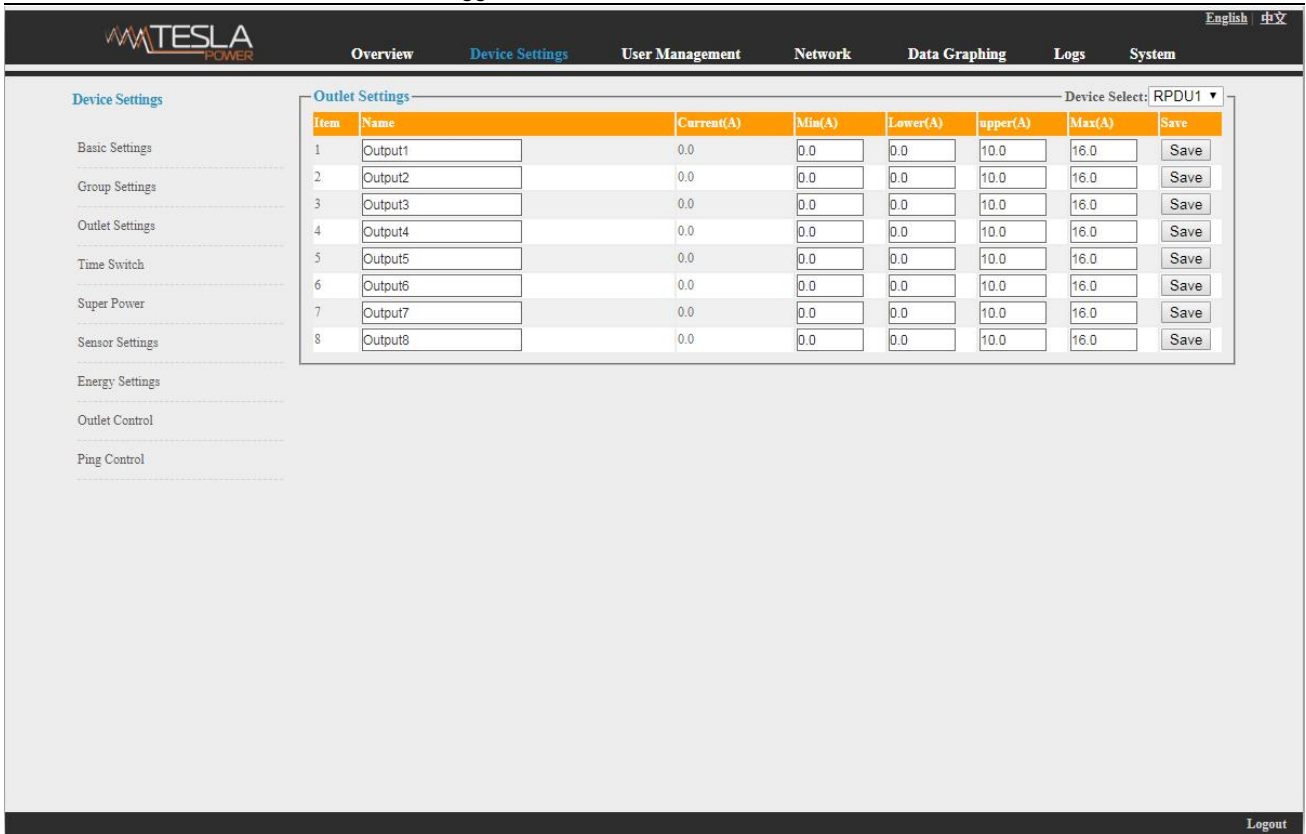

Figure 1-3-2

D. Schedule Outlet action: Use can schedule a specific time that each individual outlet will power on/off automatically, the time format is year-month-day hour:minutes, for example: 2015-05-27 13:52, tick off the box behind, then the outlet will power on/off according the time set;

Note: Please calibration the device time before schedule the outlet action

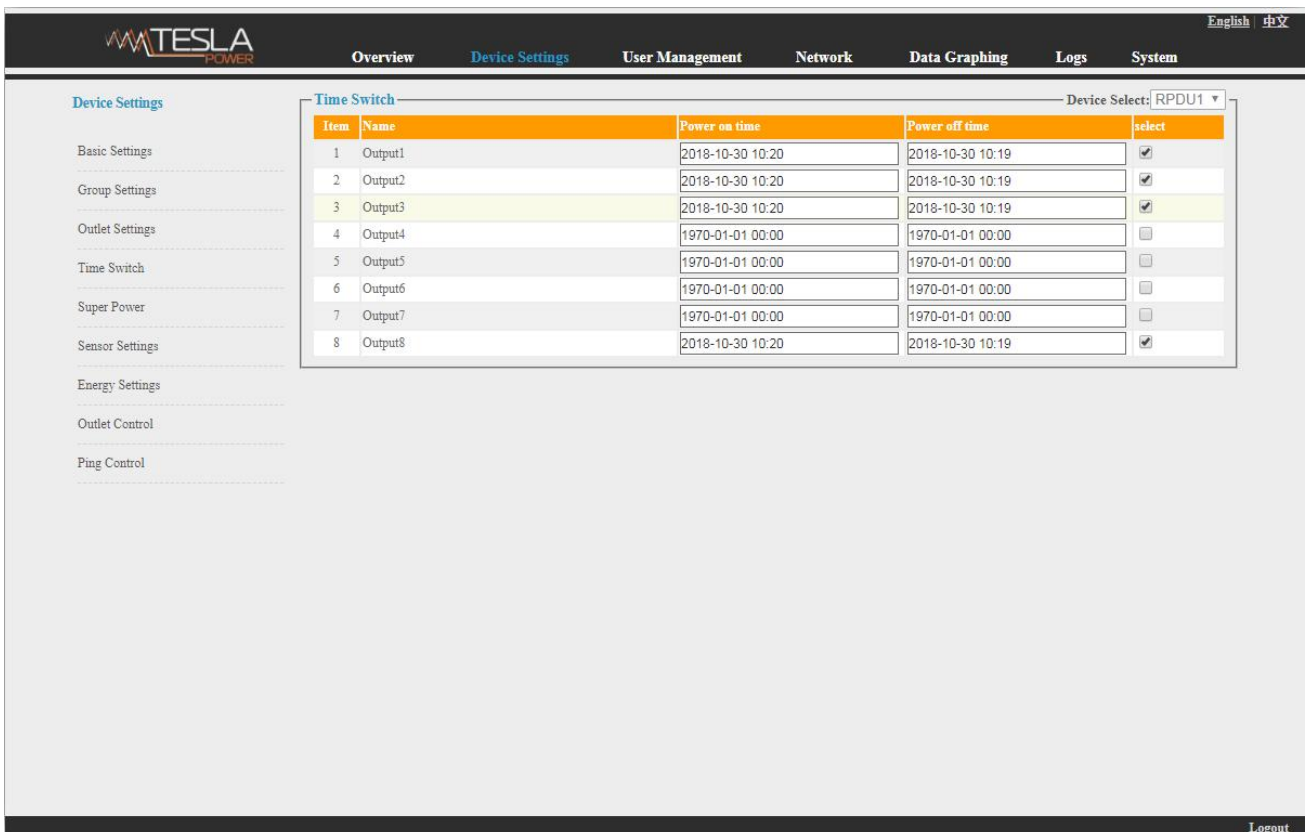

Figure 1-3-3

E. Power cut-off when overload

User can enable the power cut-off function accordingly, the PDU will cut off the overload outlet automatically when this function was ticked off. See figure 1-3-4

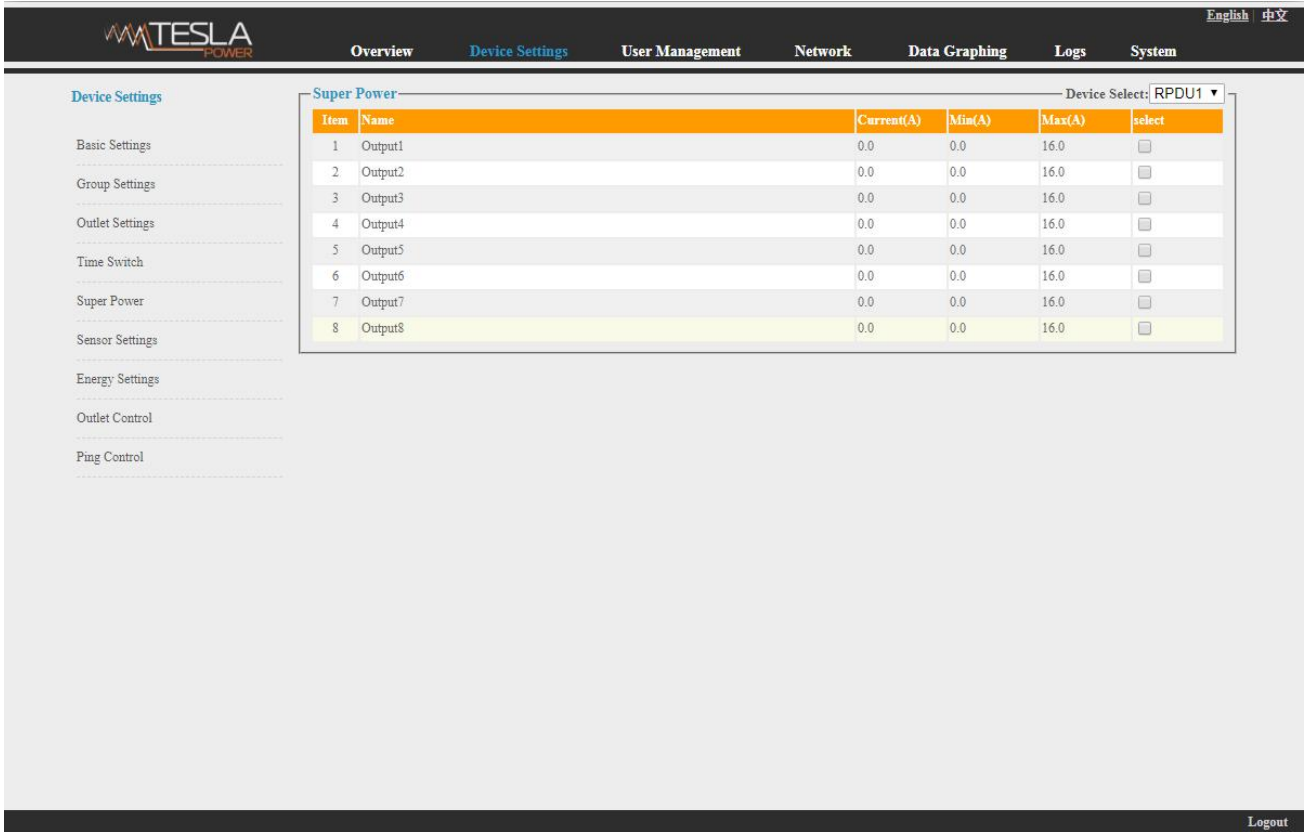

Figure 1-3-4

F. Sensor settings: set the threshold of temperature, humidity as figure 1-3-5

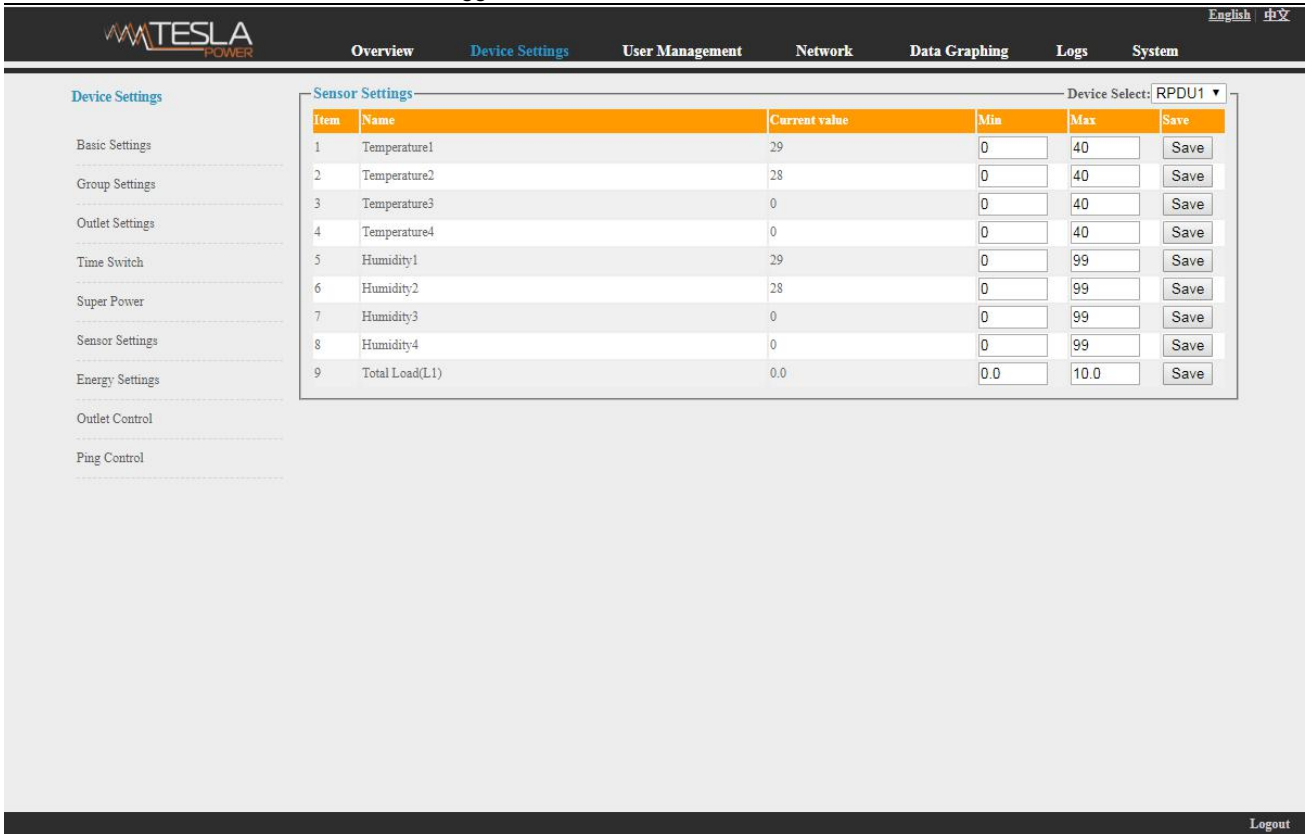

Figure 1-3-5

G. Energy setting: Click the **Energy setting** form the **Device Management** menu as Figure 1-3-6

User can view the power consumption of each individual and click the Reset button to return the kWh to zero, the total power consumption will take off the outlet consumption as well.

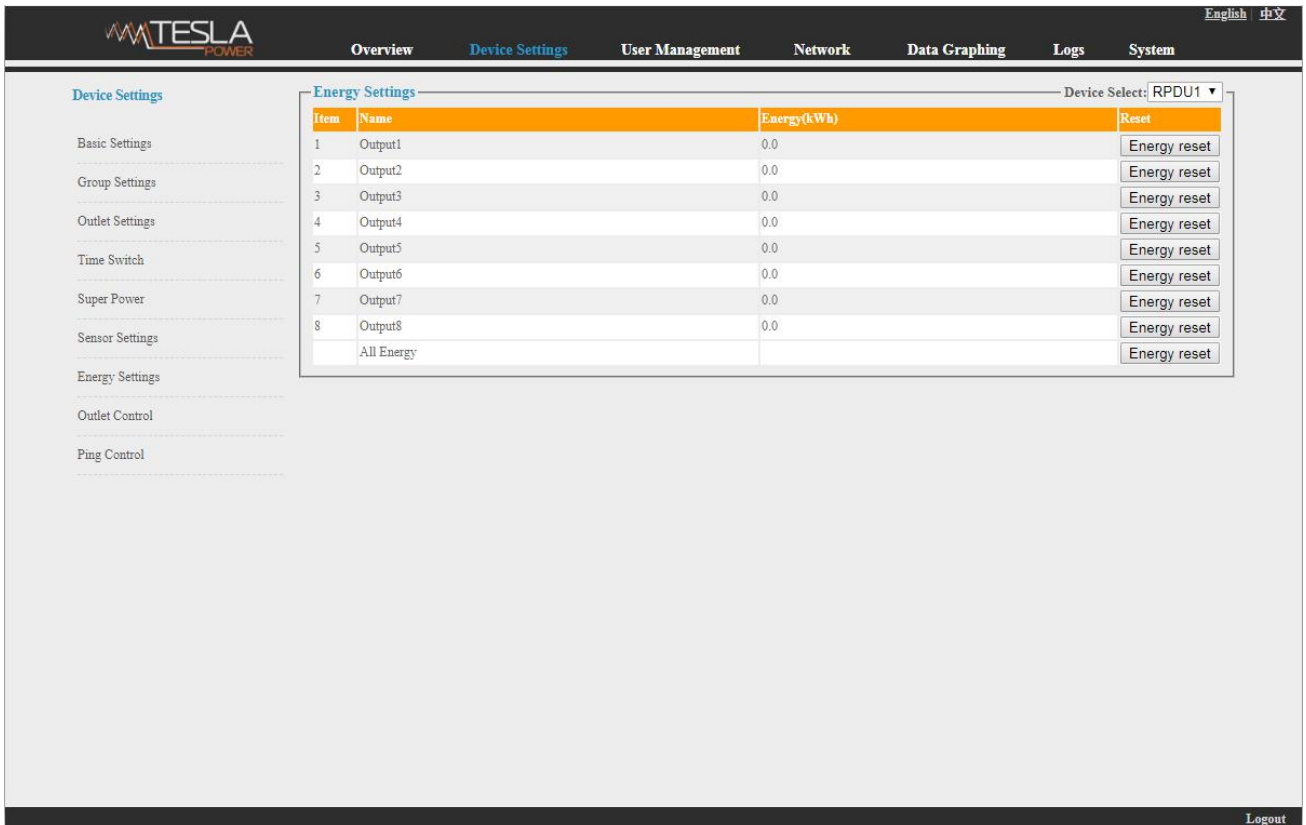

Figure 1-3-6

H. Outlet control: Click the **Outlet control** form the **Device Management** menu as Figure 1-3-6

- a. User can switch on/off/reboot each individual outlet by click the corresponding on/off/reboot buttons;
- b. Also user can switch on or off all socket at once by click the ALL on/off button

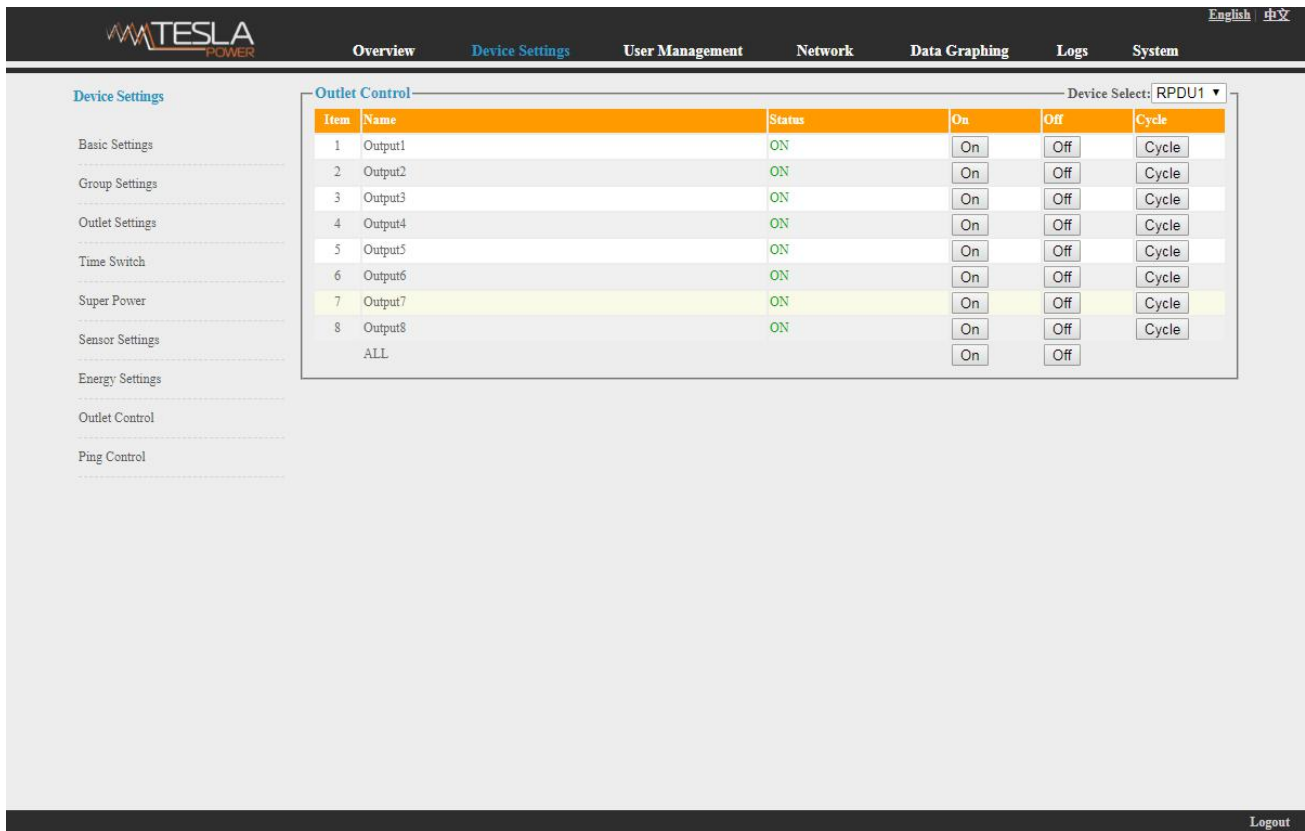

Figure 1-3-7

I. Ping Control

Use the PING command to ping the corresponding outlets network device’s IP address from the first to eighth outlets, When Ping no answer occurs, by the control of outlets’ power up/down so as to realize the power supply operation of network equipment.

Fill in the corresponding input IP address in the IP input box, which is controlled by network device.

Select the drop-down box options of ACTION, the default system command is NONE, PING- no answer, the system does not perform any operation of corresponding outlets; When you select ON / OFF / Once Options, Ping-No answer occurs, the system will perform the corresponding outlets on/off or restart an operation; When you select Cycle option, Ping No answer occurs, the corresponding outlets will repeat restart operation at intervals of time.

The interval time of outlets restart command operation is 15s (system default), the range shouldn’t be less than 3s. Click on “Apply” button, Ping function enable, when Ping function is enabled, the logs of the operation of Ping function will be generated.

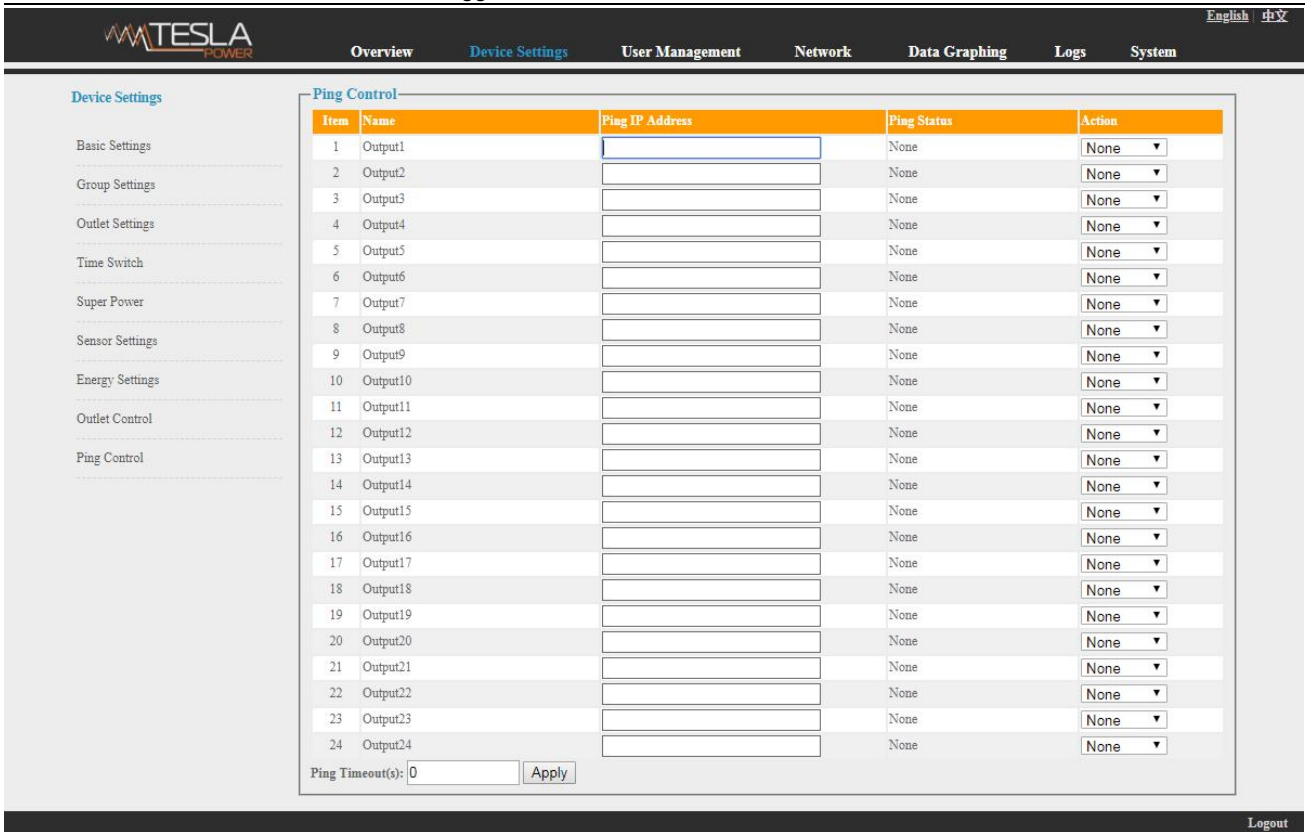

Figure1-3-8

Note: when Ping running normal, the outlets doesn't carry on any operates commands.

Ping function could be available the network device IP connect with output1 to output24.

The other outlets connect the network device IP couldn't be available this function.

3.2.1.3. User Management: Click the [User Management](#) form the navigation bar as Figure 1-4 to manage the user, user group and user access rights

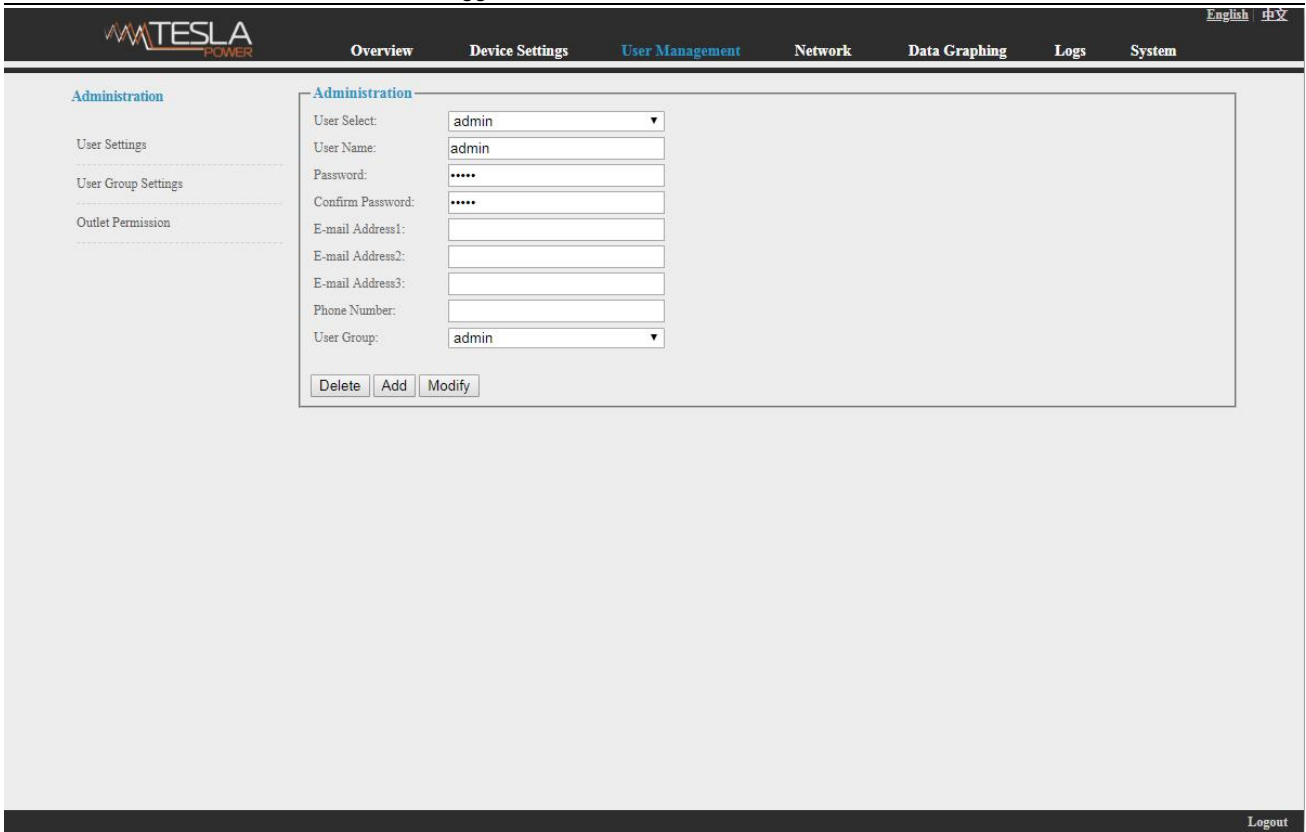

Figure 1-4

A. User Settings: Click the User settings from the User Management menu as figure 1-4

1. Create new account: Click user settings and fill in the new user name and password, click Add to finish
2. Edit account: Click User settings, fill in the changed user name and password in the right side, click Modify to finish
3. Delete account: Click User settings and select the account from the drop down list, then click Delete to finish
4. Create new user group: Click User Group Settings, fill in the new user group name and configure the corresponding rights, then click Save to finish, see as figure 1-4-1

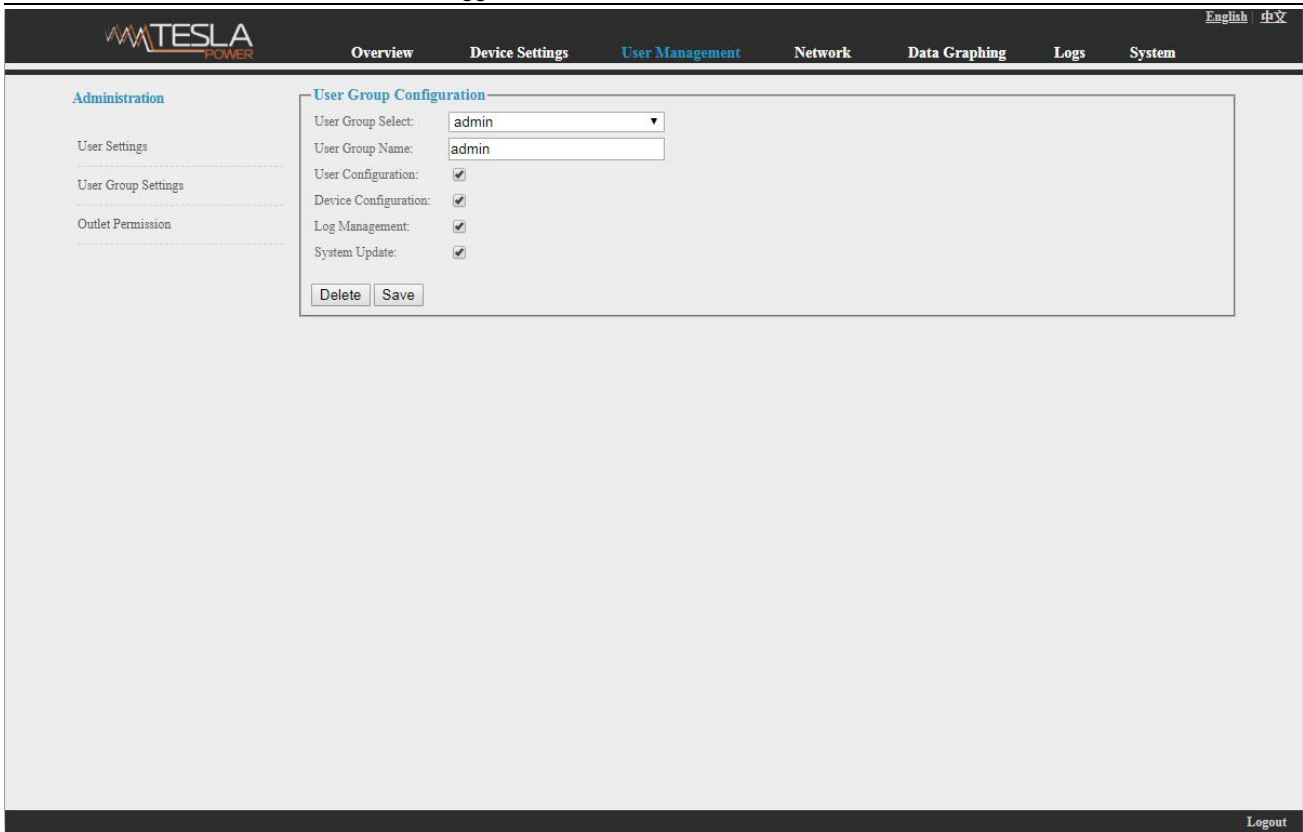

Figure 1-4-1

5. Edit the User Group: Click the User Group settings, then fill in the changed user group name and click Save to finish

6. Delete user group: Click User Group settings, select the user group from the drop down list and click Delete button to finish

7. Edit the User Group rights: Select the User Group from the drop down list and tick off the rights accordingly, click save to finish

User can assign different outlet access rights to different user groups, click Save or Delete to finish. See as figure 1-4-2

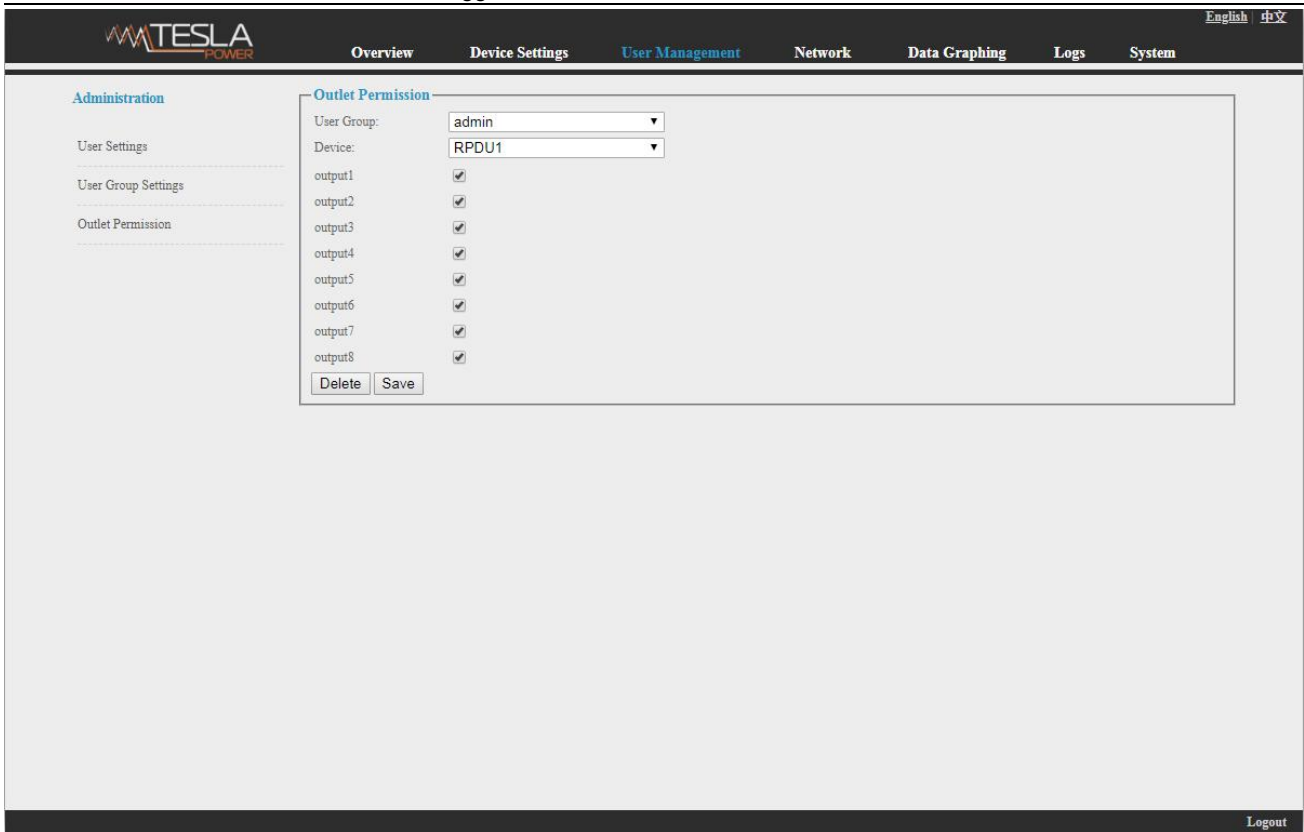

Figure 1-4-2

3.2.1.4 Network Settings: Click the Network Settings from the navigation bar as figure 1-5

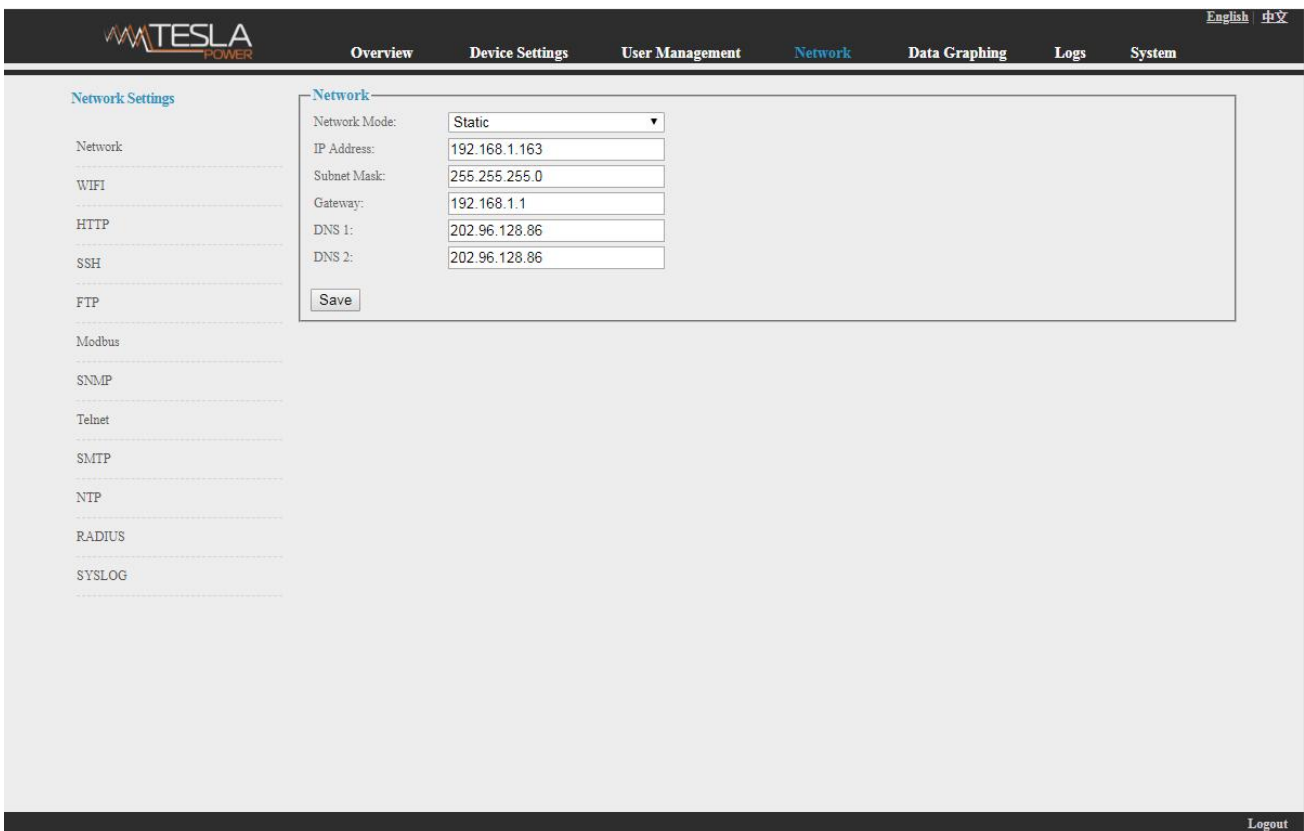

Figure 1-5

Note: the network settings including Network, WIFI, HTTP, SSH, FTP, Modbus, SNMP, Telnet, SMTP, NTP, Radius and SYSOLOG sections

A. Network: User can configure the network by manual or automatic acquisition.

a. Manual setting:

IP:192.168.1.163 (factory default IP) ;

Subnet mask:255.255.255.0

Gateway:192.168.1.1

DNS: default as 0.0.0.0;Should fill in correct DNS to ensure the email send out.

Note: please restart the software after the modification of network settings.

b. Automatic acquisition:

Select Automatic acquisition and click “Save”, then restart the software, device will get the IP automatically. IP can be viewed on LCD.

B. WIFI Settings:

Insert the wireless network card into the USB port

1. WIFI Signal Searching:

Click “Search Network” to find all the wireless network nearby.

2. Enable WIFI: select enable, fill in SSID and password and save.

3.WIFI network settings

Network mode can be manual or automatic acquisition

Manually settings as below:

IP Address: Set the WIFI IP in the LAN like 192.168.1.191

Subnet Mask: correspond to IP address like 255.255.255.0

Gateway: correspond to IP address like 192.168.1.1

DNS: default DNS is 0.0.0.0

automatic acquisition

Fill out the WIFI connection settings and save, select the automatic acquisition from the drop-down list of WIFI network settings and save. Then restart the device and system will acquire the IP address within the LAN and the address can be viewed from the LCD screen.

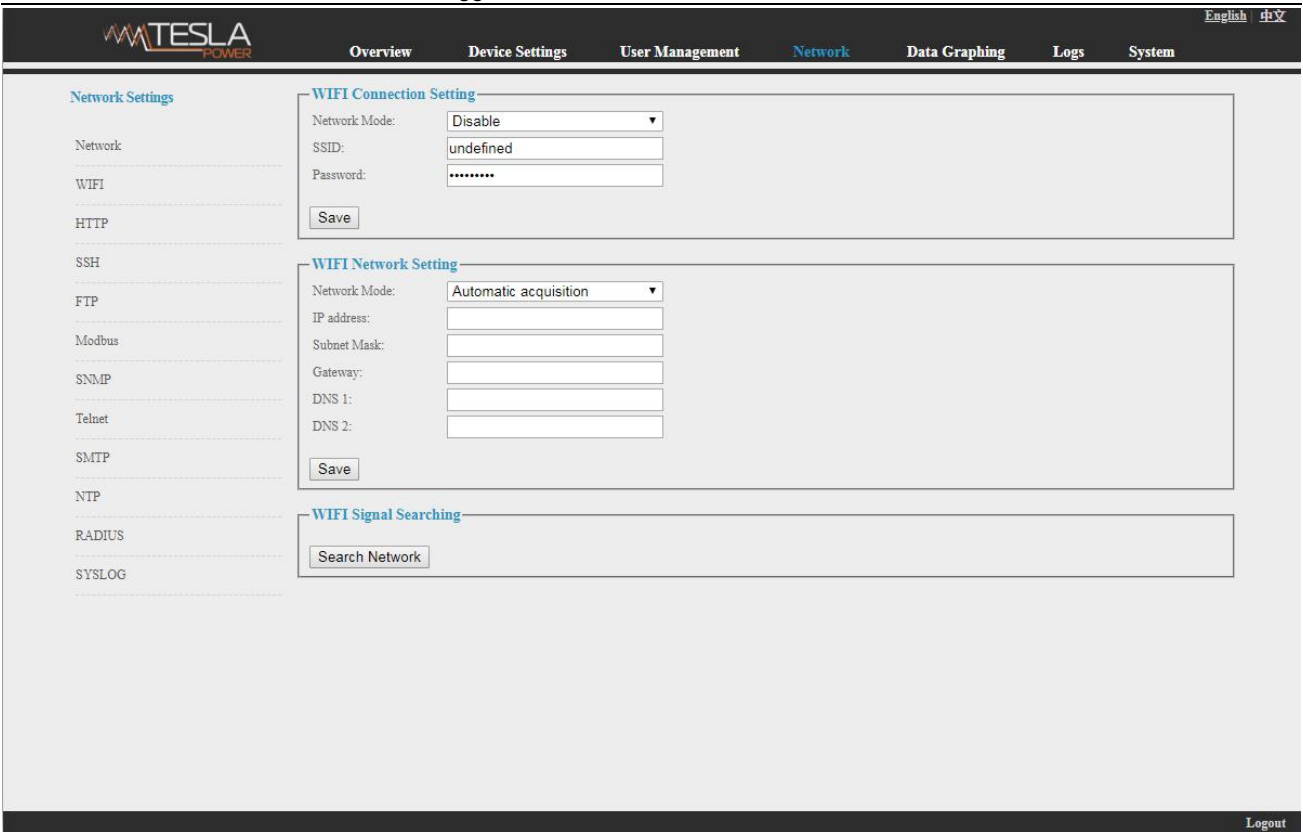

Figure 1-6

C. HTTP: fill in the correct HTTP port and save; under normal work mode, the default port is 80.

HTTPS(SSL) Mode Port: default as 443.

Note: please restart the software after the modification of HTTP settings. See figure 1-7

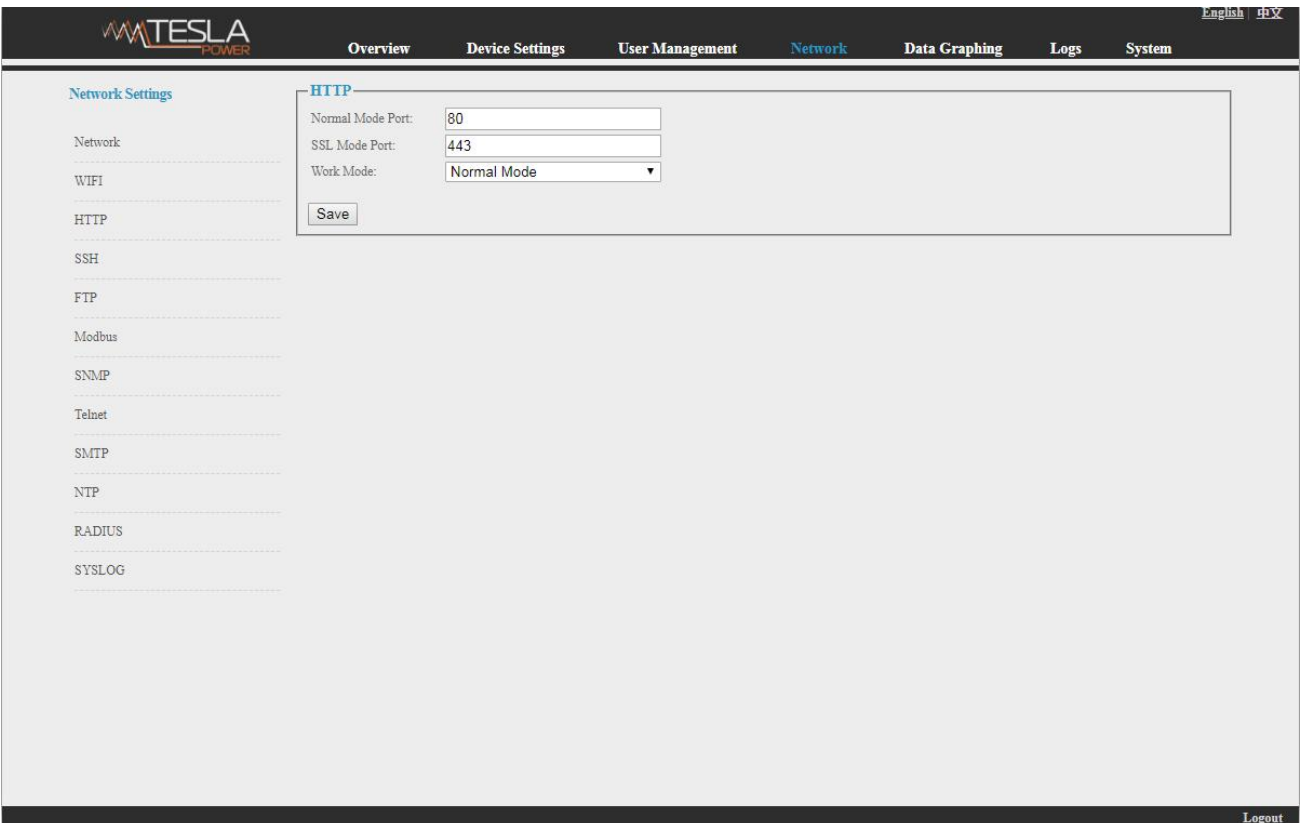

Figure 1-7

D. SSH Setting:

User can enable or disable the SSH, it require restart the device after saving the configuration. The account and password of SSH is the account and password to login to the SSH, the SSH port is 22, see figure 1-8:

Note: SSH command line access, please refer to the Telnet access instruction

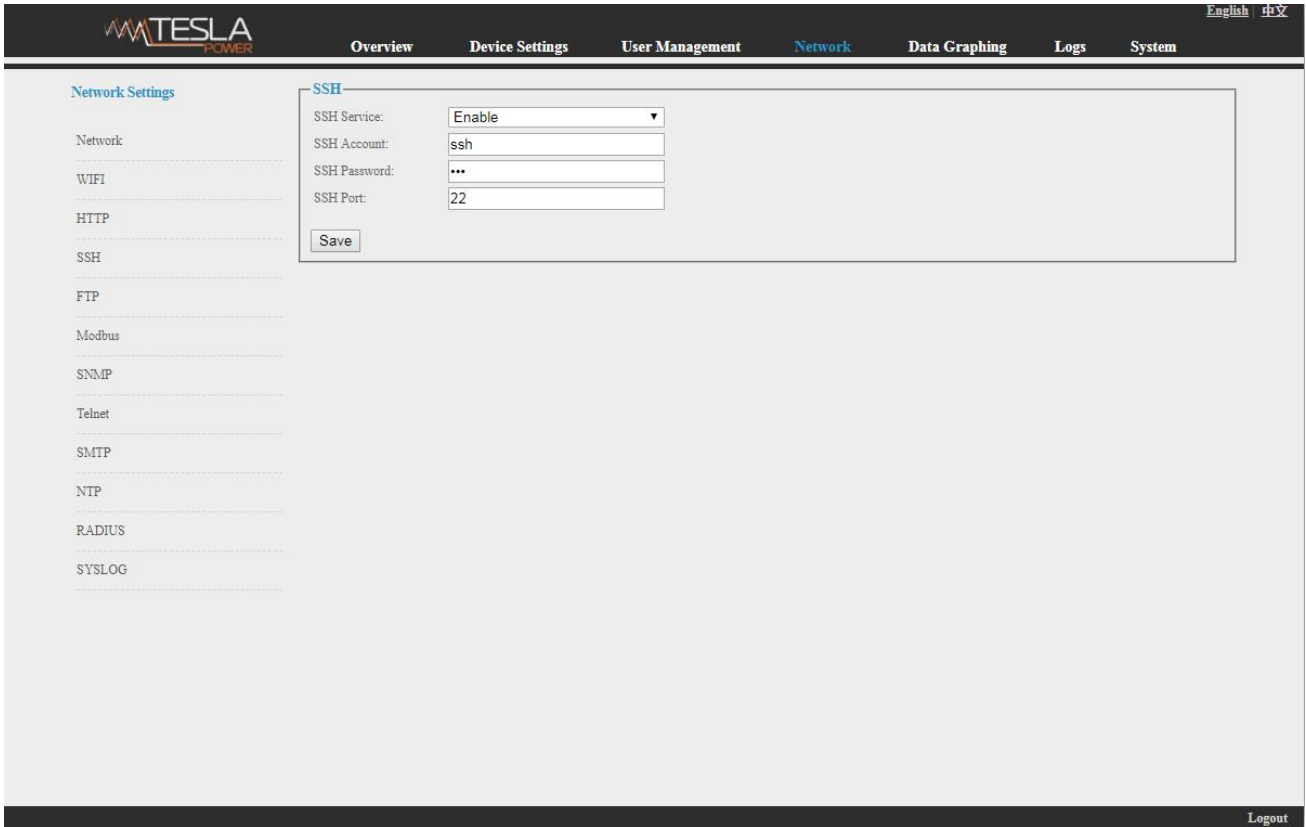

Figure 1-8

E. FTP

User can enable or disable the FTP, it require restart the device after saving the configuration. The account and password of FTP is the account and password to login to the SSH, the FTP port is 21, see figure 1-9:

Note: User can remotely upgrade by enable the FTP service

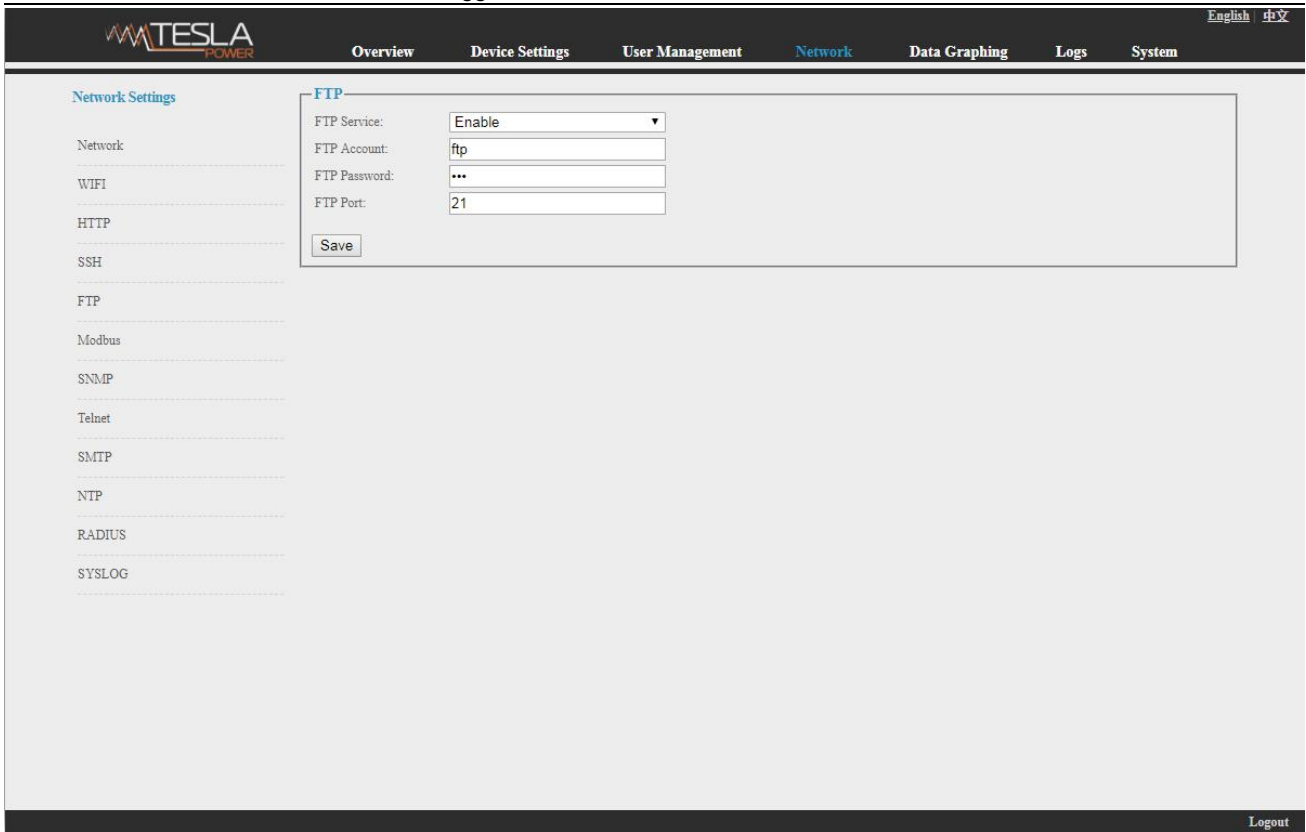

Figure 1-9

F. MODBUS

MODBUS protocol configuration includes MODBUS communication address(1-255), baud rate(9200,19200,38400,57600,115200), data bit(6,7,8), parity (N/A, even number, odd number), stop bit(1,2)

Note: The Master unit collect the data from the SER port, please refer to the MODBUS protocol detail for reference

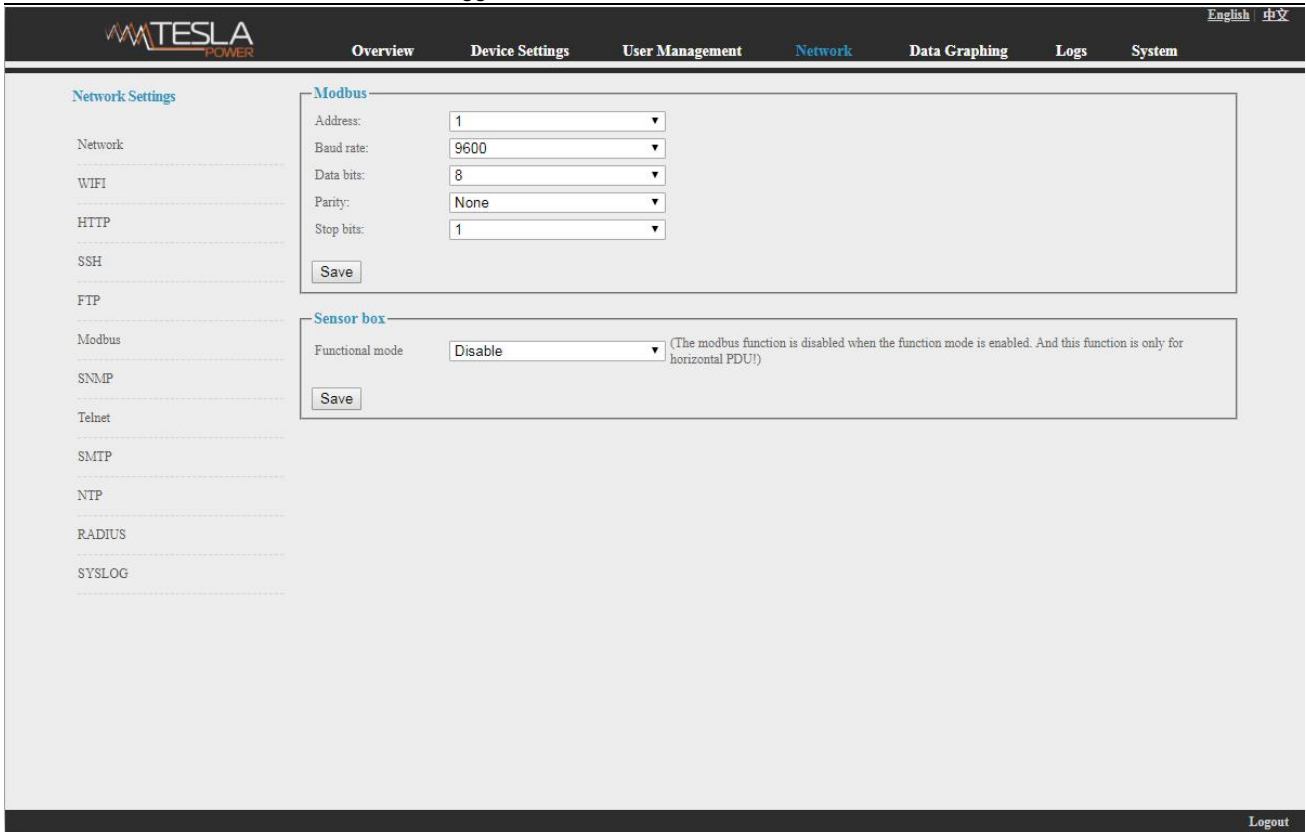

Figure 1-10

G. SNMP:

SNMP V1/V2c:

User can decide to Enable or Disable the SNMP access from the Web interface.

Enable SNMP V1 and V2C requires configuration of read community and write community. And the default “Read community” and “Write community ”is public and private. User can change it accordingly to situation.

Trap address: can set 2 trap addresses. Fill in the trap address of SNMP management platform, Trap information will be sent directly to the addresses.

SNMP server position record the server position information

SNMP v3 settings:

Select “Enable” and fill in account, password, private key.

Note: After save of the SNMP setting, software must be restarted.

For SNMP access please refer to page 24.

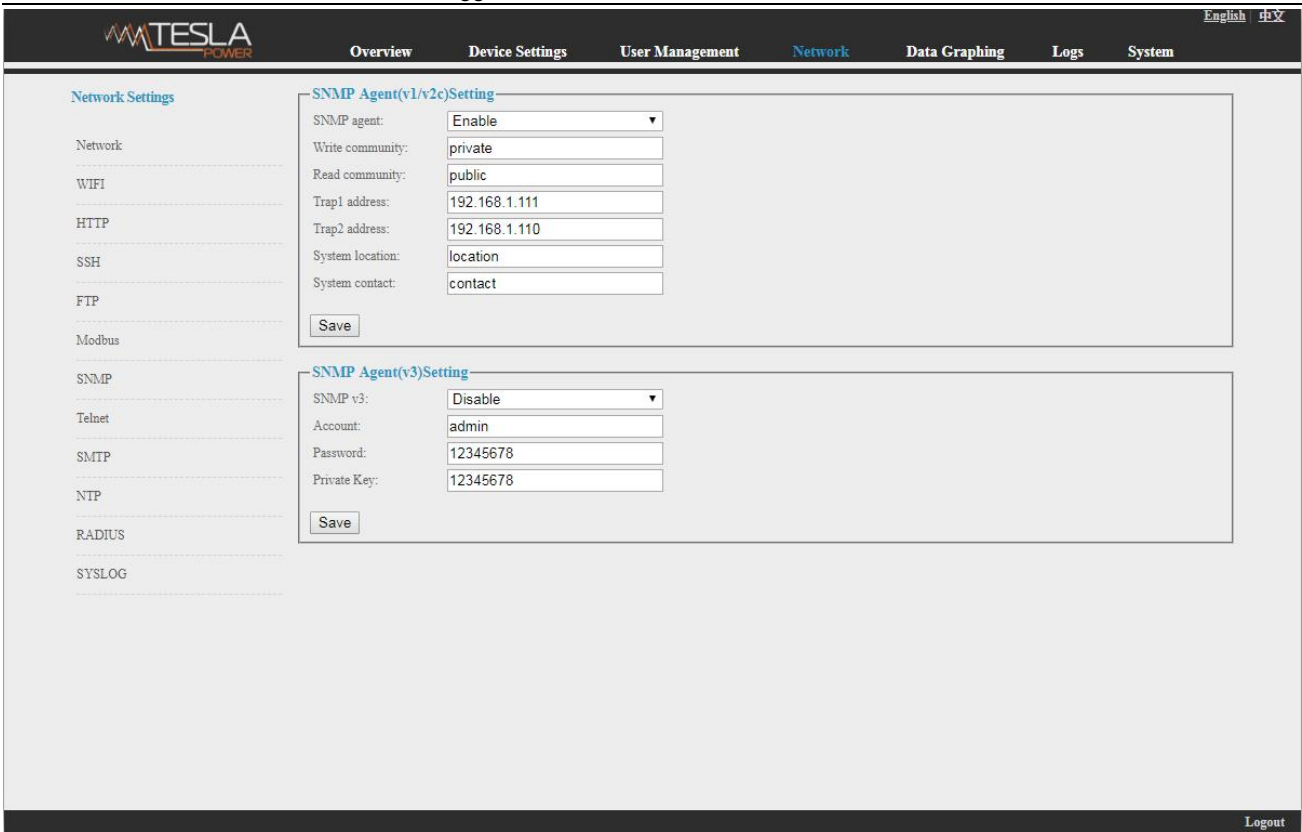

Figure 1-11

H. Telnet:

Telnet: select “Enable” or “Disable” and save, make sure to restart the software after modification.

Fill in Telnet account and password as shown in figure 1-12, Telnet port is 23.

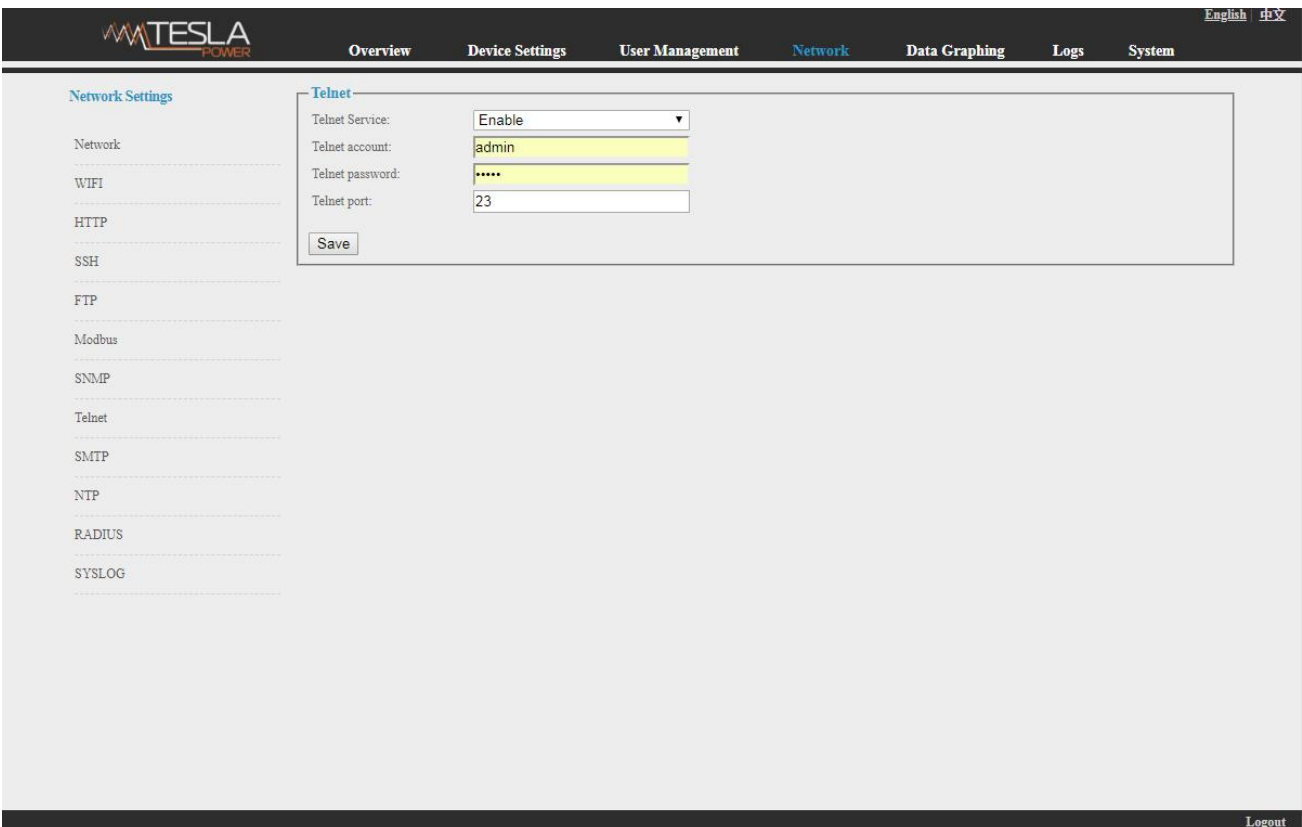

Figure 1-12

I. SMTP: Click SMTP from the network setting tap to enter the SMTP setting as figure 1-13.

Fill in the parameters of SMTP service including SMTP account, password, SMTP server, port and authentication mode. After save, must restart the software to take effect.

SMTP test: fill in the receiver account, click “Test” and then check the test receiver account. If test email received, SMTP setting is successful; if not received, please reset the SMTP.

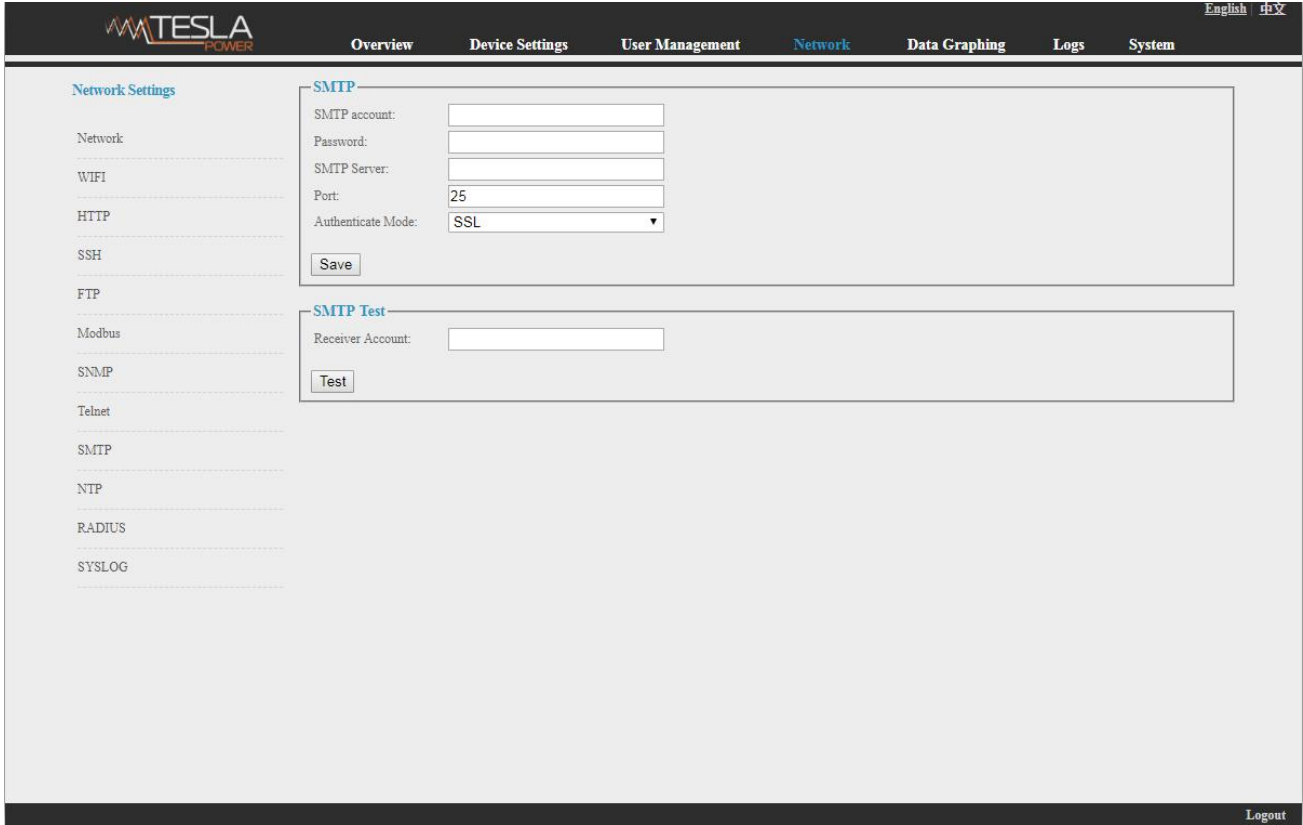

Figure 1-13

J. NTP Settings: Click NTP as shown figure 1-14 from network setting tap

Local time is the present time of the device server.

To enable or Disable the NTP service and click Save. Then restart the device.

Enable NTP, fill in the NTP server, port and select time zone, click “Save”.

Click “Synchronization”, device will update to the local system time according to the the current time zone and date from the internet

User-defined setting: must disable the NTP firstly and then fill in the date and time.

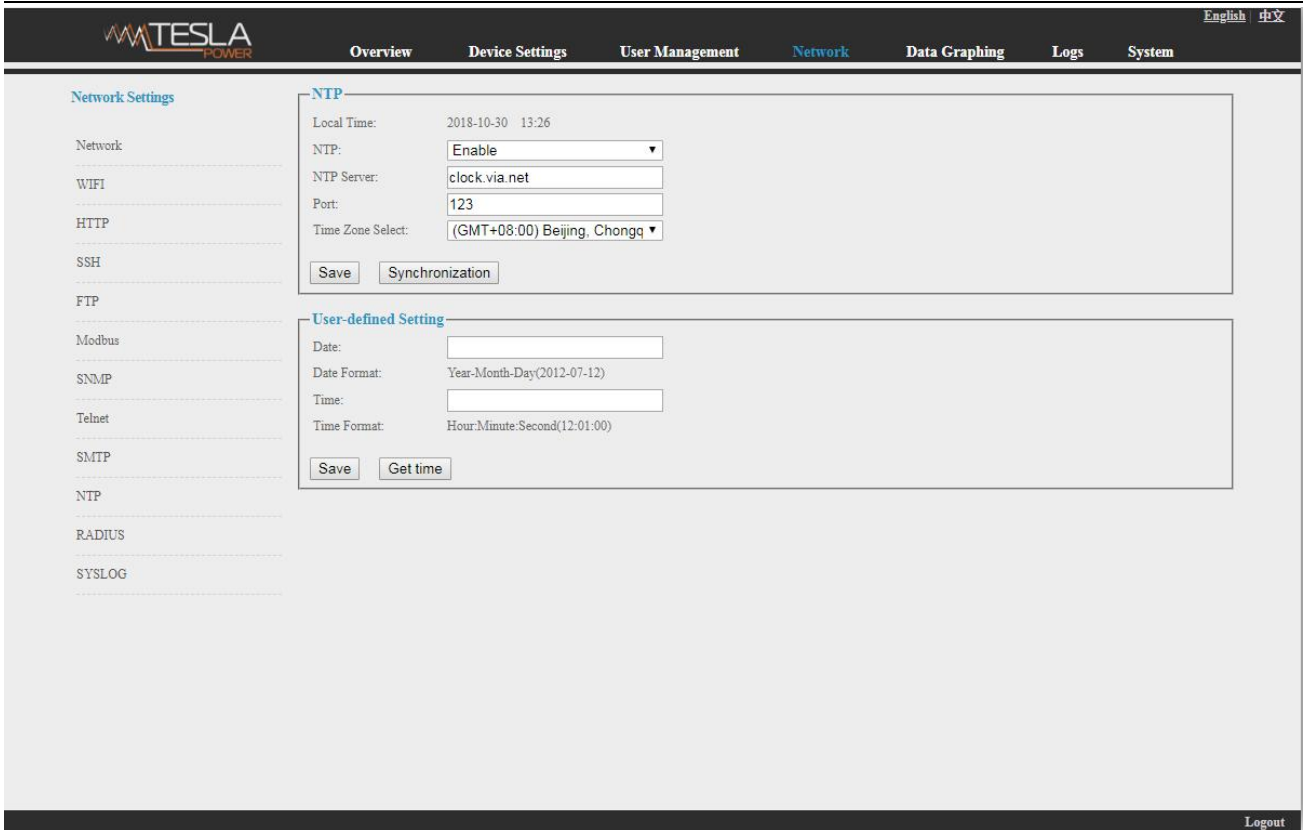

Figure 1-14

K. RADIUS

User can choose basic authentication or Radius authentication.

Select Radius authentication, device will authenticate the user account from the Radius server.

Server address: fill in the Radius server address.

Shared secret: fill in the required public key of the Radius server.

Note: please restart the software after the configuration. Then fill in the requested account and password of Radius server, after authentication, user can access the device.

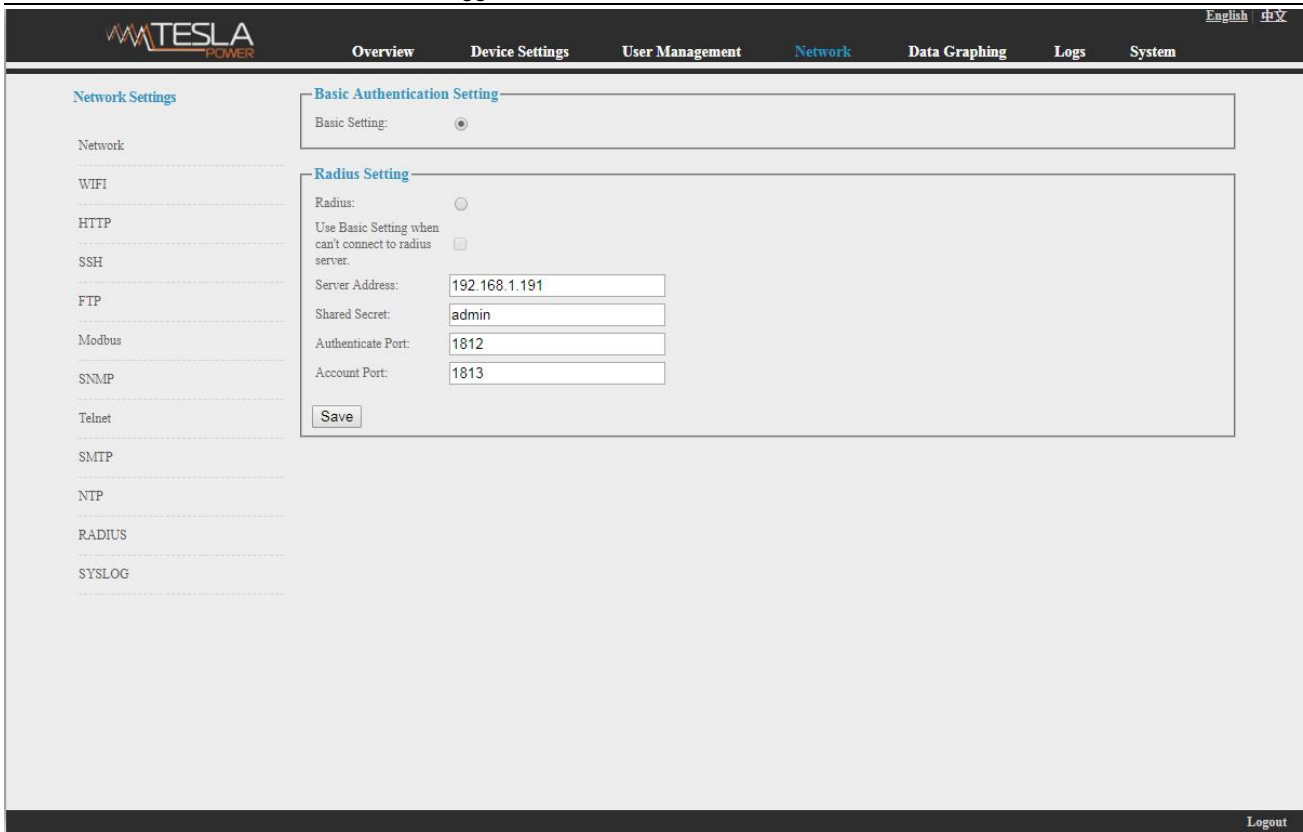

Figure 1-15

L. SYSLOG: fill in the SYSLOG server IP address and syslog protity as shown in figure 1-16

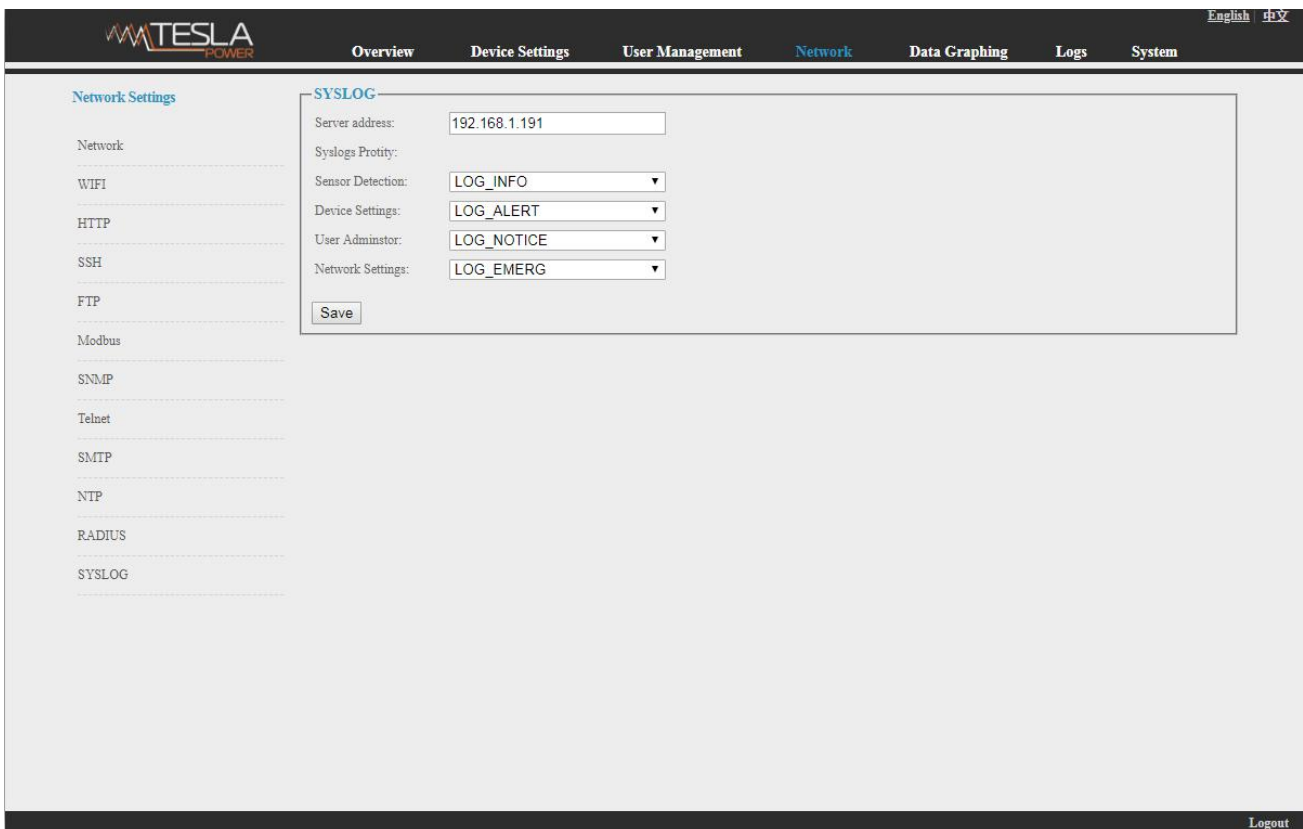

Figure 1-16

Note: SYSLOG contain the system start, service mistake during operation and command mistake information. After save the SYSLOG server address, restart the software to take effect.

2.1.5. Data Graphing

Select device and check the relative information in the past 24 hours including total power (kW), current (ampere), voltage, average temperature and humidity as illustrated in figure 1-17

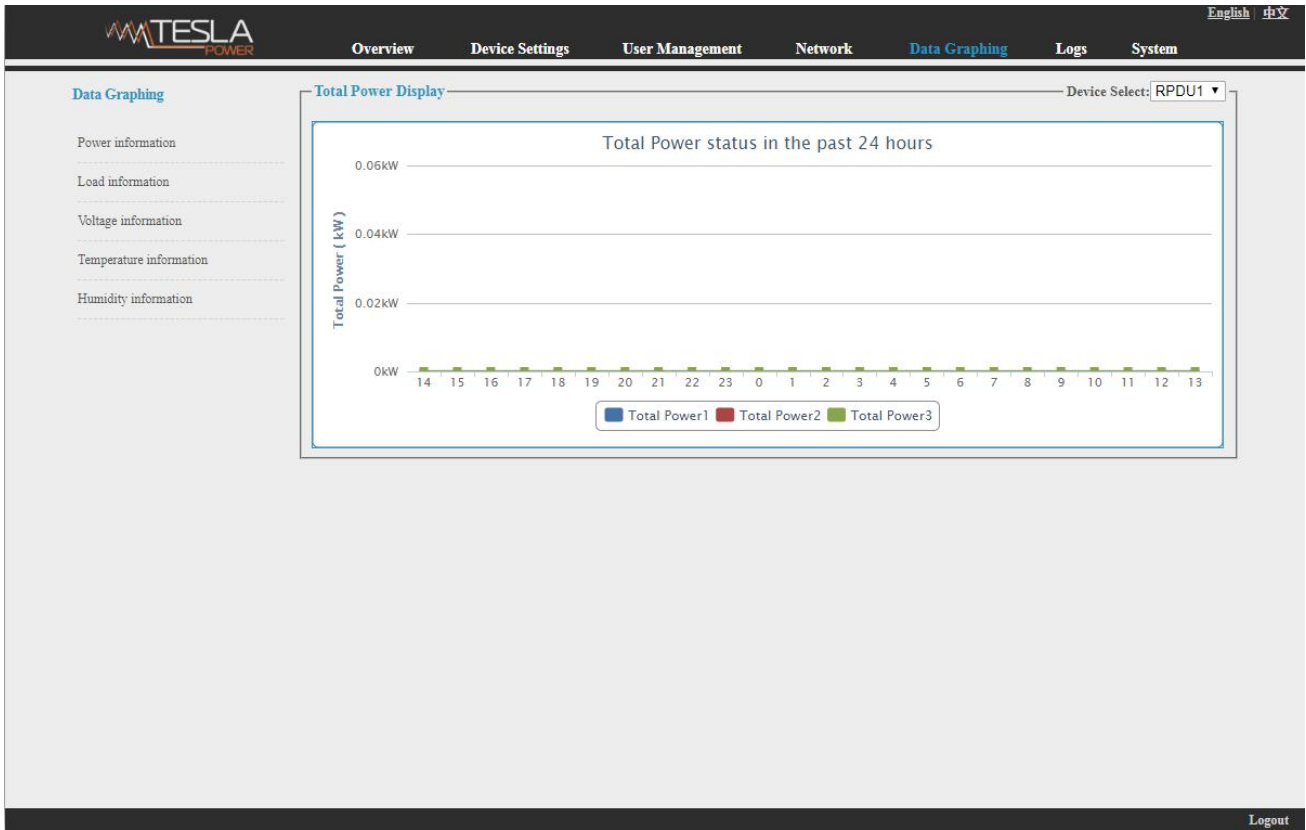

Figure 1-17

3.2.1.6、Logs

Click [Logs](#) from the navigation bar to enter the logs interface as shown in figure 1-18, it contains events, history data and energy data. See also figure 1-19 and 1-20

Logs Record: show the operation time, log type, user name and log details.

Memory capacity 100M.

To view the data:

Jump : enter the page you want to view and it will switch over to the specific page.

Page turning: by click Next or Previous to view the logs

Delete the logs:

Click the [delete logs](#), device will return the confirmation and click OK to delete all the logs.

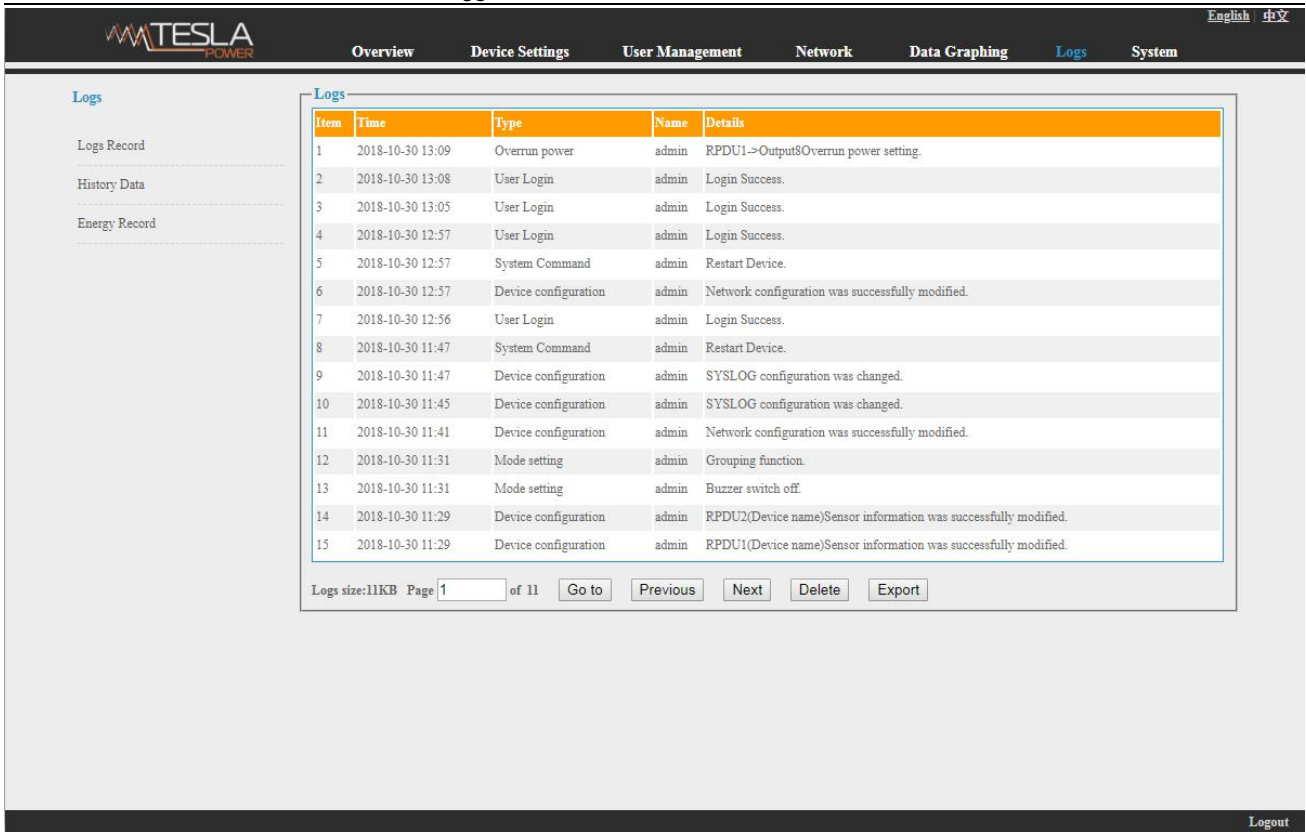

Figure 1-18

History Data: select the date, device and information type (total power, voltage, power, temperature and humidity) want to view, and then click “View” to see the history data.

Figure 1-19 shows the voltage status of 24 hours:

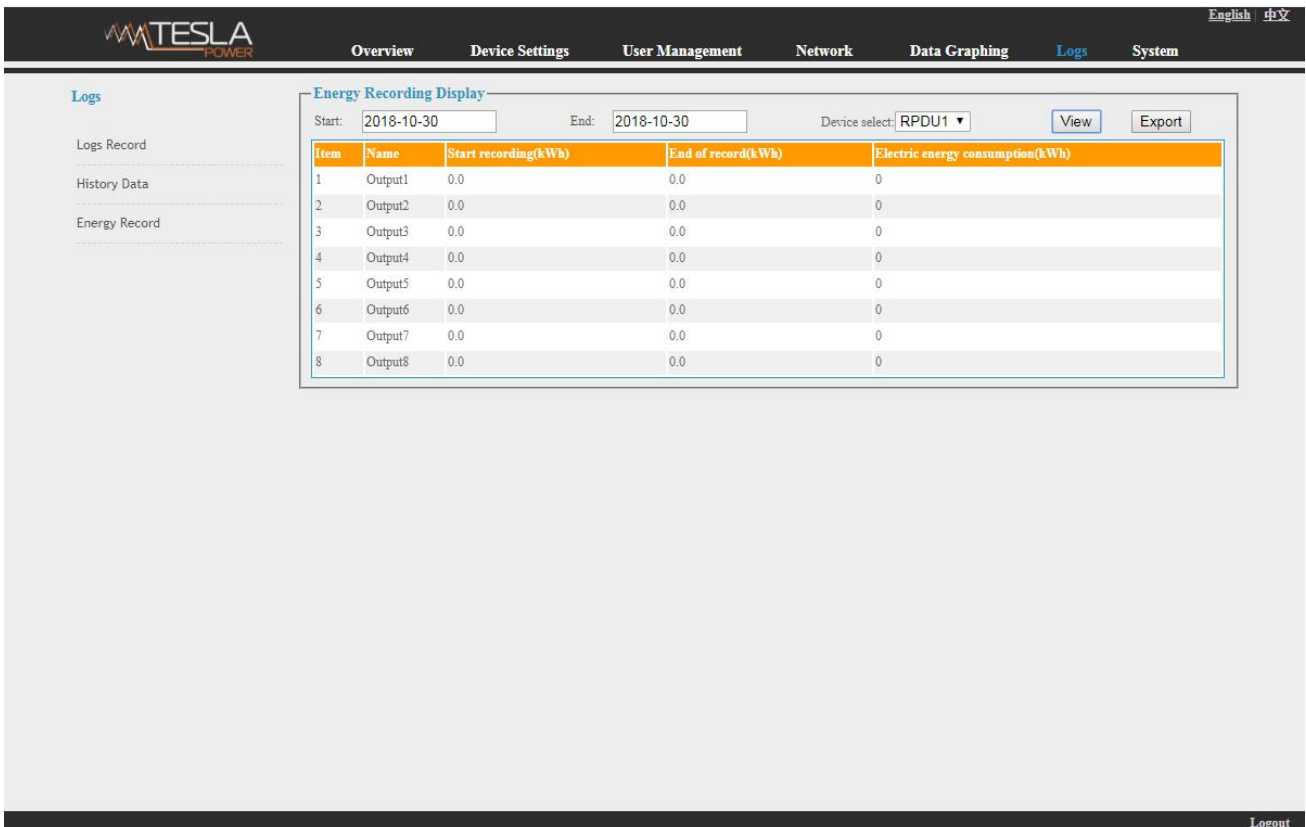

Figure 1-19

Energy Record: select the device, start and end date, and click “View”, system will show the accumulated kWh value on the two date and calculate the kWh value during that period as shown in figure 1-20:

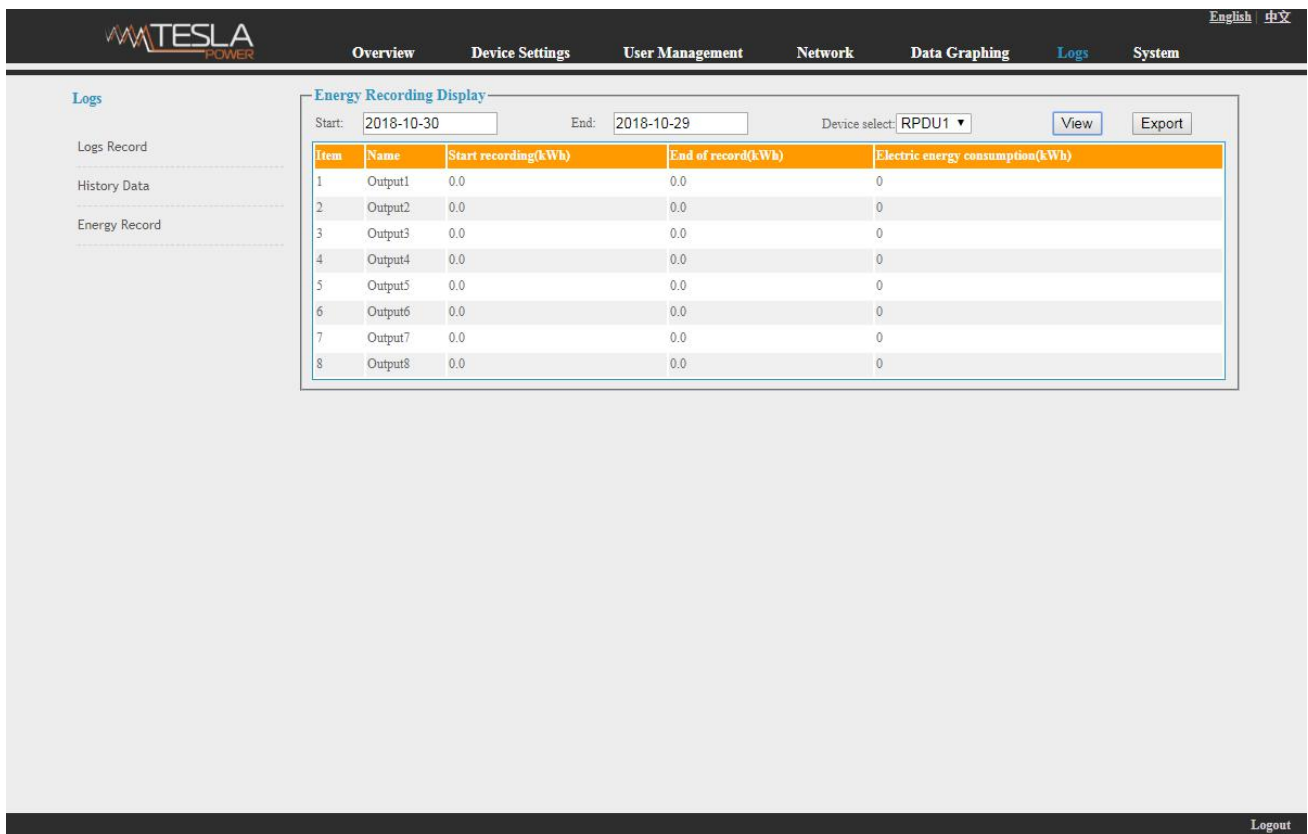

Figure 1-20

3.2.1.7. System

Click [System](#) from the navigation bar to enter the system interface as shown in figure 1-21

1. show system information: User can check system version, last update date, flash size and so on ;
2. download update tool to remotely update the software provided;
3. download user manual and MIB file ;
4. Massive data backup and quick setup of mass PDUs: Click Settings to save the devices settings, user settings and network settings through batch download, user can upload all the backup information easily by the upgrade tool.
5. User can easily upgrade the software version through the Rootfs.bin file provided by following up the instruction to upload the software.

Note: Please make sure the PDU is directly connected to the PC

Ensure no power off, no network disconnection and no operation during upgrading

6. Restart the software or restore to factory default configuration from the [System commands](#).

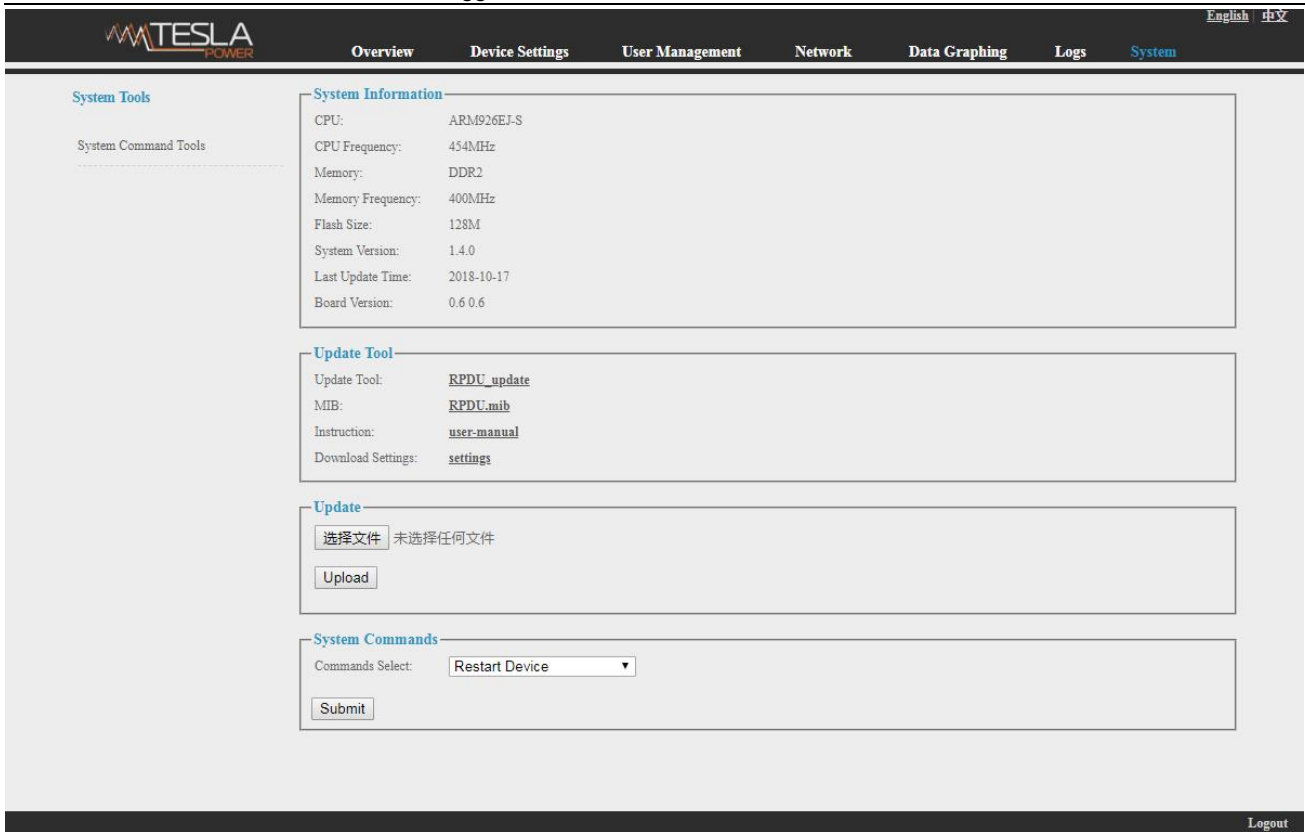

Figure 1-21

3.2.2 SNMP Access

This software support SNMP V1, V2C and V3, a MIB file can be provided at customer's request. User can view the power information and environment status and receive the alarming from the device.

After enable the SNMP function from Web interface. A SNMP management software is required to be installed(the first device can be the Master unit or Slave unit, and the others are all Slave units).

Please refer to the OID table as below:

	OID	Description
RPDUSlave X	1.3.6.1.4.1.40418.8.100.6.X	Device X
slave X Name	1.3.6.1.4.1.40418.8.100.6.X.1.1	Name of device X
slave X Type	1.3.6.1.4.1.40418.8.100.6.X.1.2	Type of device X
slave X Line One	1.3.6.1.4.1.40418.8.100.6.X.1.3	Phase one of device X
slave X Line One Power	1.3.6.1.4.1.40418.8.100.6.X.1.3.1	Power of phase one of device X
slave X Line One PF	1.3.6.1.4.1.40418.8.100.6.X.1.3.2	Power factor of the phase one of device X
slave X Line One Energy	1.3.6.1.4.1.40418.8.100.6.X.1.3.3	Energy of phase one of device X
slave X Line One Current	1.3.6.1.4.1.40418.8.100.6.X.1.3.4	Current of phase one of device X
slave X Line One Voltage	1.3.6.1.4.1.40418.8.100.6.X.1.3.5	voltage of phase one of device X
slave X Line One Current Min	1.3.6.1.4.1.40418.8.100.6.X.1.3.6	Minimum Current of phase one of device X
slave X Line One Current Max	1.3.6.1.4.1.40418.8.100.6.X.1.3.7	Maximum Current of phase one of device X

slave X Line One Voltage Min	1.3.6.1.4.1.40418.8.100.6.X.1.3.8	Minimum voltage of phase one of device X
slave X Line One Voltage Max	1.3.6.1.4.1.40418.8.100.6.X.1.3.9	Maximum voltage of phase one of device X
slave X Line Two	1.3.6.1.4.1.40418.8.100.6.X.1.4	Phase two of device X
slave X Line Two Power	1.3.6.1.4.1.40418.8.100.6.X.1.4.1	Power of phase two of device X
slave X Line Two PF	1.3.6.1.4.1.40418.8.100.6.X.1.4.2	Power factor of the phase two of device X
slave X Line Two Energy	1.3.6.1.4.1.40418.8.100.6.X.1.4.3	Energy of phase two of device X
slave X Line Two Current	1.3.6.1.4.1.40418.8.100.6.X.1.4.4	Current of phase two of device X
slave X Line Two Voltage	1.3.6.1.4.1.40418.8.100.6.X.1.4.5	voltage of phase two of device X
slave X Line Two Current Min	1.3.6.1.4.1.40418.8.100.6.X.1.4.6	Minimum Current of phase two of device X
slave X Line Two Current Max	1.3.6.1.4.1.40418.8.100.6.X.1.4.7	Maximum Current of phase two of device X
slave X Line Two Voltage Min	1.3.6.1.4.1.40418.8.100.6.X.1.4.8	Minimum voltage of phase two of device X
slave X Line Two Voltage Max	1.3.6.1.4.1.40418.8.100.6.X.1.4.9	Maximum voltage of phase two of device X
slave X Line Three	1.3.6.1.4.1.40418.8.100.6.X.1.5	Phase three of device X
slave X Line Three Power	1.3.6.1.4.1.40418.8.100.6.X.1.5.1	Power of phase three of device X
slave X Line Three PF	1.3.6.1.4.1.40418.8.100.6.X.1.5.2	Power factor of the phase three of device X
slave X Line Three Energy	1.3.6.1.4.1.40418.8.100.6.X.1.5.3	Energy of phase three of device X
slave X Line Three Current	1.3.6.1.4.1.40418.8.100.6.X.1.5.4	Current of phase three of device X
slave X Line Three Voltage	1.3.6.1.4.1.40418.8.100.6.X.1.5.5	voltage of phase three of device X
slave X Line Three Current Min	1.3.6.1.4.1.40418.8.100.6.X.1.5.6	Minimum Current of phase three of device X
slave X Line Three Current Max	1.3.6.1.4.1.40418.8.100.6.X.1.5.7	Maximum Current of phase three of device X
slave X Line Three Voltage Min	1.3.6.1.4.1.40418.8.100.6.X.1.5.8	Minimum voltage of phase three of device X
slave X Line Three Voltage Max	1.3.6.1.4.1.40418.8.100.6.X.1.5.9	Maximum voltage of phase three of device X
slave X TempHum	1.3.6.1.4.1.40418.8.100.6.X.1.6	The temperature and humidity of device X
slave X TempOne	1.3.6.1.4.1.40418.8.100.6.X.1.6.1	The temperature one of device X
slave X TempTwo	1.3.6.1.4.1.40418.8.100.6.X.1.6.2	The temperature two of device X
slave X TempThree	1.3.6.1.4.1.40418.8.100.6.X.1.6.3	The temperature three of device X
slave X TempFour	1.3.6.1.4.1.40418.8.100.6.X.1.6.4	The temperature four of device X
slave X HumOne	1.3.6.1.4.1.40418.8.100.6.X.1.6.5	The humidity one of device X
slave X HumTwo	1.3.6.1.4.1.40418.8.100.6.X.1.6.6	The humidity two of device X
slave X HumThree	1.3.6.1.4.1.40418.8.100.6.X.1.6.7	The humidity three of device X
slave X HumFour	1.3.6.1.4.1.40418.8.100.6.X.1.6.8	The humidity four of device X
slave X DoorOne	1.3.6.1.4.1.40418.8.100.6.X.1.6.9	The door one of device X
slave X DoorTwo	1.3.6.1.4.1.40418.8.100.6.X.1.6.10	The door two of device X
slave X Smoke	1.3.6.1.4.1.40418.8.100.6.X.1.6.11	The smoke of device X

slave X Water	1.3.6.1.4.1.40418.8.100.6.X.1.6.12	The water of device X
slave X Output Number	1.3.6.1.4.1.40418.8.100.6.X.1.7	The outlet quantity of device X
slave X Output Name	1.3.6.1.4.1.40418.8.100.6.X.1.8	The outlet name of device X
slave X Output Name One	1.3.6.1.4.1.40418.8.100.6.X.1.8.1	The name of outlet 1 of device X
slave X Output Name Two	1.3.6.1.4.1.40418.8.100.6.X.1.8.2	The name of outlet 2 of device X
slave X Output Name Three	1.3.6.1.4.1.40418.8.100.6.X.1.8.3	The name of outlet 3 of device X
slave X Output Name Four	1.3.6.1.4.1.40418.8.100.6.X.1.8.4	The name of outlet 4 of device X
slave X Output Name Five	1.3.6.1.4.1.40418.8.100.6.X.1.8.5	The name of outlet 5 of device X
slave X Output Name Six	1.3.6.1.4.1.40418.8.100.6.X.1.8.6	The name of outlet 6 of device X
slave X Output Name Seven	1.3.6.1.4.1.40418.8.100.6.X.1.8.7	The name of outlet 7 of device X
slave X Output Name Eight	1.3.6.1.4.1.40418.8.100.6.X.1.8.8	The name of outlet 8 of device X
slave X Output Name Nine	1.3.6.1.4.1.40418.8.100.6.X.1.8.9	The name of outlet 9 of device X
slave X Output Name Ten	1.3.6.1.4.1.40418.8.100.6.X.1.8.10	The name of outlet 10 of device X
slave X Output Name Eleven	1.3.6.1.4.1.40418.8.100.6.X.1.8.11	The name of outlet 11 of device X
slave X Output Name Twelve	1.3.6.1.4.1.40418.8.100.6.X.1.8.12	The name of outlet 12 of device X
slave X Output Name Thirteen	1.3.6.1.4.1.40418.8.100.6.X.1.8.13	The name of outlet 13 of device X
slave X Output Name Fourteen	1.3.6.1.4.1.40418.8.100.6.X.1.8.14	The name of outlet 14 of device X
slave X Output Name Fifteen	1.3.6.1.4.1.40418.8.100.6.X.1.8.15	The name of outlet 15 of device X
slave X Output Name Sixteen	1.3.6.1.4.1.40418.8.100.6.X.1.8.16	The name of outlet 16 of device X
slave X Output Name Seventeen	1.3.6.1.4.1.40418.8.100.6.X.1.8.17	The name of outlet 17 of device X
slave X Output Name Eighteen	1.3.6.1.4.1.40418.8.100.6.X.1.8.18	The name of outlet 18 of device X
slave X Output Name Nineteen	1.3.6.1.4.1.40418.8.100.6.X.1.8.19	The name of outlet 19 of device X
slave X Output Name Twenty	1.3.6.1.4.1.40418.8.100.6.X.1.8.20	The name of outlet 20 of device X
slave X Output Name TwentyOne	1.3.6.1.4.1.40418.8.100.6.X.1.8.21	The name of outlet 21 of device X
slave X Output Name TwentyTwo	1.3.6.1.4.1.40418.8.100.6.X.1.8.22	The name of outlet 22 of device X

slave X Output Name TwentyThree	1.3.6.1.4.1.40418.8.100.6.X.1.8.23	The name of outlet 23 of device X
slave X Output Name TwentyFour	1.3.6.1.4.1.40418.8.100.6.X.1.8.24	The name of outlet 24 of device X
slave X Output Status	1.3.6.1.4.1.40418.8.100.6.X.1.9	The outlet status of device X
slave X Output Status One	1.3.6.1.4.1.40418.8.100.6.X.1.9.1	The outlet 1 status of device X
slave X Output Status Two	1.3.6.1.4.1.40418.8.100.6.X.1.9.2	The outlet 2 status of device X
slave X Output Status Three	1.3.6.1.4.1.40418.8.100.6.X.1.9.3	The outlet 3 status of device X
slave X Output Status Four	1.3.6.1.4.1.40418.8.100.6.X.1.9.4	The outlet 4 status of device X
slave X Output Status Five	1.3.6.1.4.1.40418.8.100.6.X.1.9.5	The outlet 5 status of device X
slave X Output Status Six	1.3.6.1.4.1.40418.8.100.6.X.1.9.6	The outlet 6 status of device X
slave X Output Status Seven	1.3.6.1.4.1.40418.8.100.6.X.1.9.7	The outlet 7 status of device X
slave X Output Status Eight	1.3.6.1.4.1.40418.8.100.6.X.1.9.8	The outlet 8 status of device X
slave X Output Status Nine	1.3.6.1.4.1.40418.8.100.6.X.1.9.9	The outlet 9 status of device X
slave X Output Status Ten	1.3.6.1.4.1.40418.8.100.6.X.1.9.10	The outlet 10status of device X
slave X Output Status Eleven	1.3.6.1.4.1.40418.8.100.6.X.1.9.11	The outlet 11 status of device X
slave X Output Status Twelve	1.3.6.1.4.1.40418.8.100.6.X.1.9.12	The outlet 12 status of device X
slave X Output Status Thirteen	1.3.6.1.4.1.40418.8.100.6.X.1.9.13	The outlet 13 status of device X
slave X Output Status Fourteen	1.3.6.1.4.1.40418.8.100.6.X.1.9.14	The outlet 14 status of device X
slave X Output Status Fifteen	1.3.6.1.4.1.40418.8.100.6.X.1.9.15	The outlet 15 status of device X
slave X Output Status Sixteen	1.3.6.1.4.1.40418.8.100.6.X.1.9.16	The outlet 16 status of device X
slave X Output Status Seventeen	1.3.6.1.4.1.40418.8.100.6.X.1.9.17	The outlet 17 status of device X
slave X Output Status Eighteen	1.3.6.1.4.1.40418.8.100.6.X.1.9.18	The outlet 18 status of device X
slave X Output Status Nineteen	1.3.6.1.4.1.40418.8.100.6.X.1.9.19	The outlet 19 status of device X
slave X Output Status Twenty	1.3.6.1.4.1.40418.8.100.6.X.1.9.20	The outlet 20 status of device X
slave X Output Status TwentyOne	1.3.6.1.4.1.40418.8.100.6.X.1.9.21	The outlet 21 status of device X

slave X Output Status TwentyTwo	1.3.6.1.4.1.40418.8.100.6.X.1.9.22	The outlet 22 status of device X
slave X Output Status TwentyThree	1.3.6.1.4.1.40418.8.100.6.X.1.9.23	The outlet 23 status of device X
slave X Output Status TwentyFour	1.3.6.1.4.1.40418.8.100.6.X.1.9.24	The outlet 24 status of device X
slave X Output Current	1.3.6.1.4.1.40418.8.100.6.X.1.10	The outlet current of device X
slave X Output Current One	1.3.6.1.4.1.40418.8.100.6.X.1.10.1	The current of outlet 1 of device X
slave X Output Current Two	1.3.6.1.4.1.40418.8.100.6.X.1.10.2	The current of outlet 2 of device X
slave X Output Current Three	1.3.6.1.4.1.40418.8.100.6.X.1.10.3	The current of outlet 3 of device X
slave X Output Current Four	1.3.6.1.4.1.40418.8.100.6.X.1.10.4	The current of outlet 4 of device X
slave X Output Current Five	1.3.6.1.4.1.40418.8.100.6.X.1.10.5	The current of outlet 5 of device X
slave X Output Current Six	1.3.6.1.4.1.40418.8.100.6.X.1.10.6	The current of outlet 6 of device X
slave X Output Current Seven	1.3.6.1.4.1.40418.8.100.6.X.1.10.7	The current of outlet 7 of device X
slave X Output Current Eight	1.3.6.1.4.1.40418.8.100.6.X.1.10.8	The current of outlet 8 of device X
slave X Output Current Nine	1.3.6.1.4.1.40418.8.100.6.X.1.10.9	The current of outlet 9 of device X
slave X Output Current Ten	1.3.6.1.4.1.40418.8.100.6.X.1.10.10	The current of outlet 10 of device X
slave X Output Current Eleven	1.3.6.1.4.1.40418.8.100.6.X.1.10.11	The current of outlet 11 of device X
slave X Output Current Twelve	1.3.6.1.4.1.40418.8.100.6.X.1.10.12	The current of outlet 12 of device X
slave X Output Current Thirteen	1.3.6.1.4.1.40418.8.100.6.X.1.10.13	The current of outlet 13 of device X
slave X Output Current Fourteen	1.3.6.1.4.1.40418.8.100.6.X.1.10.14	The current of outlet 14 of device X
slave X Output Current Fifteen	1.3.6.1.4.1.40418.8.100.6.X.1.10.15	The current of outlet 15 of device X
slave X Output Current Sixteen	1.3.6.1.4.1.40418.8.100.6.X.1.10.16	The current of outlet 16 of device X
slave X Output Current Seventeen	1.3.6.1.4.1.40418.8.100.6.X.1.10.17	The current of outlet 17 of device X
slave X Output Current Eighteen	1.3.6.1.4.1.40418.8.100.6.X.1.10.18	The current of outlet 18 of device X
slave X Output Current Nineteen	1.3.6.1.4.1.40418.8.100.6.X.1.10.19	The current of outlet 19 of device X
slave X Output Current Twenty	1.3.6.1.4.1.40418.8.100.6.X.1.10.20	The current of outlet 20 of device X

slave X Output Current TwentyOne	1.3.6.1.4.1.40418.8.100.6.X.1.10.2 1	The current of outlet 21 of device X
slave X Output Current TwentyTwo	1.3.6.1.4.1.40418.8.100.6.X.1.10.2 2	The current of outlet 22 of device X
slave X Output Current TwentyThree	1.3.6.1.4.1.40418.8.100.6.X.1.10.2 3	The current of outlet 23 of device X
slave X Output Current TwentyFour	1.3.6.1.4.1.40418.8.100.6.X.1.10.2 4	The current of outlet 24 of device X
slave X Output Current Min	1.3.6.1.4.1.40418.8.100.6.X.1.11	The outlet Minimum current of device X
slave X Output Current Min One	1.3.6.1.4.1.40418.8.100.6.X.1.11.1	The Minimum current of outlet 1 of device X
slave X Output Current Min Two	1.3.6.1.4.1.40418.8.100.6.X.1.11.2	The Minimum current of outlet 2 of device X
slave X Output Current Min Three	1.3.6.1.4.1.40418.8.100.6.X.1.11.3	The Minimum current of outlet 3 of device X
slave X Output Current Min Four	1.3.6.1.4.1.40418.8.100.6.X.1.11.4	The Minimum current of outlet 4 of device X
slave X Output Current Min Five	1.3.6.1.4.1.40418.8.100.6.X.1.11.5	The Minimum current of outlet 5 of device X
slave X Output Current Min Six	1.3.6.1.4.1.40418.8.100.6.X.1.11.6	The Minimum current of outlet 6 of device X
slave X Output Current Min Seven	1.3.6.1.4.1.40418.8.100.6.X.1.11.7	The Minimum current of outlet 7 of device X
slave X Output Current Min Eight	1.3.6.1.4.1.40418.8.100.6.X.1.11.8	The Minimum current of outlet 8 of device X
slave X Output Current Min Nine	1.3.6.1.4.1.40418.8.100.6.X.1.11.9	The Minimum current of outlet 9 of device X
slave X Output Current Min Ten	1.3.6.1.4.1.40418.8.100.6.X.1.11.1 0	The Minimum current of outlet 10 of device X
slave X Output Current Min Eleven	1.3.6.1.4.1.40418.8.100.6.X.1.11.1 1	The Minimum current of outlet 11 of device X
slave X Output Current Min Twelve	1.3.6.1.4.1.40418.8.100.6.X.1.11.1 2	The Minimum current of outlet 12 of device X
slave X Output Current Min Thirteen	1.3.6.1.4.1.40418.8.100.6.X.1.11.1 3	The Minimum current of outlet 13 of device X
slave X Output Current Min Fourteen	1.3.6.1.4.1.40418.8.100.6.X.1.11.1 4	The Minimum current of outlet 14 of device X
slave X Output Current Min Fifteen	1.3.6.1.4.1.40418.8.100.6.X.1.11.1 5	The Minimum current of outlet 15 of device X
slave X Output Current Min Sixteen	1.3.6.1.4.1.40418.8.100.6.X.1.11.1 6	The Minimum current of outlet 16 of device X
slave X Output Current Min Seventeen	1.3.6.1.4.1.40418.8.100.6.X.1.11.1 7	The Minimum current of outlet 17 of device X
slave X Output Current Min Eighteen	1.3.6.1.4.1.40418.8.100.6.X.1.11.1 8	The Minimum current of outlet 18 of device X
slave X Output Current Min Nineteen	1.3.6.1.4.1.40418.8.100.6.X.1.11.1 9	The Minimum current of outlet 19 of device X

slave X Output Current Min Twenty	1.3.6.1.4.1.40418.8.100.6.X.1.11.2 0	The Minimum current of outlet 20 of device X
slave X Output Current Min TwentyOne	1.3.6.1.4.1.40418.8.100.6.X.1.11.2 1	The Minimum current of outlet 21 of device X
slave X Output Current Min TwentyTwo	1.3.6.1.4.1.40418.8.100.6.X.1.11.2 2	The Minimum current of outlet 22 of device X
slave X Output Current Min TwentyThree	1.3.6.1.4.1.40418.8.100.6.X.1.11.2 3	The Minimum current of outlet 23 of device X
slave X Output Current Min TwentyFour	1.3.6.1.4.1.40418.8.100.6.X.1.11.2 4	The Minimum current of outlet 24 of device X
slave X Output Current Max	1.3.6.1.4.1.40418.8.100.6.X.1.12	The Minimum outlet current of device X
slave X Output Current Max One	1.3.6.1.4.1.40418.8.100.6.X.1.12.1	The Maximum current of outlet 1 of device X
slave X Output Current Max Two	1.3.6.1.4.1.40418.8.100.6.X.1.12.2	The Maximum current of outlet 2 of device X
slave X Output Current Max Three	1.3.6.1.4.1.40418.8.100.6.X.1.12.3	The Maximum current of outlet 3 of device X
slave X Output Current Max Four	1.3.6.1.4.1.40418.8.100.6.X.1.12.4	The Maximum current of outlet 4 of device X
slave X Output Current Max Five	1.3.6.1.4.1.40418.8.100.6.X.1.12.5	The Maximum current of outlet 5 of device X
slave X Output Current Max Six	1.3.6.1.4.1.40418.8.100.6.X.1.12.6	The Maximum current of outlet 6 of device X
slave X Output Current Max Seven	1.3.6.1.4.1.40418.8.100.6.X.1.12.7	The Maximum current of outlet 7 of device X
slave X Output Current Max Eight	1.3.6.1.4.1.40418.8.100.6.X.1.12.8	The Maximum current of outlet 8 of device X
slave X Output Current Max Nine	1.3.6.1.4.1.40418.8.100.6.X.1.12.9	The Maximum current of outlet 9 of device X
slave X Output Current Max Ten	1.3.6.1.4.1.40418.8.100.6.X.1.12.1 0	The Maximum current of outlet 10 of device X
slave X Output Current Max Eleven	1.3.6.1.4.1.40418.8.100.6.X.1.12.1 1	The Maximum current of outlet 11 of device X
slave X Output Current Max Twelve	1.3.6.1.4.1.40418.8.100.6.X.1.12.1 2	The Maximum current of outlet 12 of device X
slave X Output Current Max	1.3.6.1.4.1.40418.8.100.6.X.1.12.1 3	The Maximum current of outlet 13 of device X

Thirteen		
slave X Output Current Max Fourteen	1.3.6.1.4.1.40418.8.100.6.X.1.12.1 4	The Maximum current of outlet 14 of device X
slave X Output Current Max Fifteen	1.3.6.1.4.1.40418.8.100.6.X.1.12.1 5	The Maximum current of outlet 15 of device X
slave X Output Current Max Sixteen	1.3.6.1.4.1.40418.8.100.6.X.1.12.1 6	The Maximum current of outlet 16 of device X
slave X Output Current Max Seventeen	1.3.6.1.4.1.40418.8.100.6.X.1.12.1 7	The Maximum current of outlet 17 of device X
slave X Output Current Max Eighteen	1.3.6.1.4.1.40418.8.100.6.X.1.12.1 8	The Maximum current of outlet 18 of device X
slave X Output Current Max Nineteen	1.3.6.1.4.1.40418.8.100.6.X.1.12.1 9	The Maximum current of outlet 19 of device X
slave X Output Current Max Twenty	1.3.6.1.4.1.40418.8.100.6.X.1.12.2 0	The Maximum current of outlet 20 of device X
slave X Output Current Max TwentyOne	1.3.6.1.4.1.40418.8.100.6.X.1.12.2 1	The Maximum current of outlet 21 of device X
slave X Output Current Max TwentyTwo	1.3.6.1.4.1.40418.8.100.6.X.1.12.2 2	The Maximum current of outlet 22 of device X
slave X Output Current Max TwentyThree	1.3.6.1.4.1.40418.8.100.6.X.1.12.2 3	The Maximum current of outlet 23 of device X
slave X Output Current Max TwentyFour	1.3.6.1.4.1.40418.8.100.6.X.1.12.2 4	The Maximum current of outlet 24 of device X
slave X Output Current Energy	1.3.6.1.4.1.40418.8.100.6.X.1.13	The energy of device X
slave X Output Current Energy One	1.3.6.1.4.1.40418.8.100.6.X.1.13.1	The energy of outlet 1 of device X
slave X Output Current Energy Two	1.3.6.1.4.1.40418.8.100.6.X.1.13.2	The energy of outlet 2 of device X
slave X Output Current Energy Three	1.3.6.1.4.1.40418.8.100.6.X.1.13.3	The energy of outlet 3 of device X
slave X Output Current Energy Four	1.3.6.1.4.1.40418.8.100.6.X.1.13.4	The energy of outlet 4 of device X
slave X Output Current Energy	1.3.6.1.4.1.40418.8.100.6.X.1.13.5	The energy of outlet 5 of device X

Five		
slave X Output Current Energy		
Six	1.3.6.1.4.1.40418.8.100.6.X.1.13.6	The energy of outlet 6 of device X
slave X Output Current Energy		
Seven	1.3.6.1.4.1.40418.8.100.6.X.1.13.7	The energy of outlet 7 of device X
slave X Output Current Energy		
Eight	1.3.6.1.4.1.40418.8.100.6.X.1.13.8	The energy of outlet 8 of device X
slave X Output Current Energy		
Nine	1.3.6.1.4.1.40418.8.100.6.X.1.13.9	The energy of outlet 9 of device X
slave X Output Current Energy		
Ten	1.3.6.1.4.1.40418.8.100.6.X.1.13.10	The energy of outlet 10 of device X
slave X Output Current Energy		
Eleven	1.3.6.1.4.1.40418.8.100.6.X.1.13.11	The energy of outlet 11 of device X
slave X Output Current Energy		
Twelve	1.3.6.1.4.1.40418.8.100.6.X.1.13.12	The energy of outlet 12 of device X
slave X Output Current Energy		
Thirteen	1.3.6.1.4.1.40418.8.100.6.X.1.13.13	The energy of outlet 13 of device X
slave X Output Current Energy		
Fourteen	1.3.6.1.4.1.40418.8.100.6.X.1.13.14	The energy of outlet 14 of device X
slave X Output Current Energy		
Fifteen	1.3.6.1.4.1.40418.8.100.6.X.1.13.15	The energy of outlet 15 of device X
slave X Output Current Energy		
Sixteen	1.3.6.1.4.1.40418.8.100.6.X.1.13.16	The energy of outlet 16 of device X
slave X Output Current Energy		
Seventeen	1.3.6.1.4.1.40418.8.100.6.X.1.13.17	The energy of outlet 17 of device X
slave X Output Current Energy		
Eighteen	1.3.6.1.4.1.40418.8.100.6.X.1.13.18	The energy of outlet 18 of device X
slave X Output Current Energy		
Nineteen	1.3.6.1.4.1.40418.8.100.6.X.1.13.19	The energy of outlet 19 of device X
slave X Output Current Energy		
Twenty	1.3.6.1.4.1.40418.8.100.6.X.1.13.20	The energy of outlet 20 of device X
slave X Output Current Energy		
	1.3.6.1.4.1.40418.8.100.6.X.1.13.21	The energy of outlet 21 of device X

TwentyOne		
slave X Output Current Energy TwentyTwo	1.3.6.1.4.1.40418.8.100.6.X.1.13.2 2	The energy of outlet 22 of device X
slave X Output Current Energy TwentyThree	1.3.6.1.4.1.40418.8.100.6.X.1.13.2 3	The energy of outlet 23 of device X
slave X Output Current Energy TwentyFour	1.3.6.1.4.1.40418.8.100.6.X.1.13.2 4	The energy of outlet 24 of device X

B. To view the device and sensor status by table format via SNMPc software:

Table 2-1 The outlet status information table

Menu	Description
RPDU Device xx	Device xx
Slave xx line xx	Phase xx of device xx
Slave xx line xx Power	Power of phase xx of device xx
Slave xx line xx PF	Power Factor of phase xx of device xx
Slave xx line xx Energy	Energy of phase xx of device xx
Slave xx line xx Current	Current of phase xx of device xx
Slave xx line xx Voltage	Voltage of phase xx of device xx
Slave xx line xx Current MIN	The Minimum current of phase xx of device xx
Slave xx line xx Current Max	The Maximum current of phase xx of device xx
Slave xx line xx Voltage Min	The Minimum voltage of phase xx of device xx
Slave xx line xx Voltage Max	The Maximum voltage of phase xx of device xx
Slave xx temp	The temperature of device xx
Slave xx hum	The humidity of device xx
Slave xx temp Min	The Minimum temperature value of device xx
Slave xx temp Max	The Maximum temperature value of device xx
Slave xx hum Min	The Minimum humidity value of device xx
Slave xx hum Max	The Maximum humidity value of device xx
Slave xx output name xx	The outlet name of outlet xx of device xx
Slave xx output status xx	The on/off status of outlet xx of device xx
Slave xx output current xx	The current of outlet xx of device xx
Slave xx output current Min xx	The Minimum current of outlet xx of device xx

Slave xx output current Max xx	The Maximum current of outlet xx of device
Slave xx output current Energy xx	The energy of outlet xx of device xx
Slave xx name	The name of device xx
Slave xx Type	The type of device xx
Slave xx output number	The outlet quantity of device xx

3.2.3 Telnet Access

The device supports Telnet access, after enter the username and password, user can remotely monitor and management the device. Telnet access support daisy-chain as well to enable the user to manage up to 5 devices.

3.2.3.1. To open the Telnet client  by Start→ Run command→enter “Telnet” in the input box and click OK

3.2.3.2. Enter the IP address as illustrated in figure 2-4

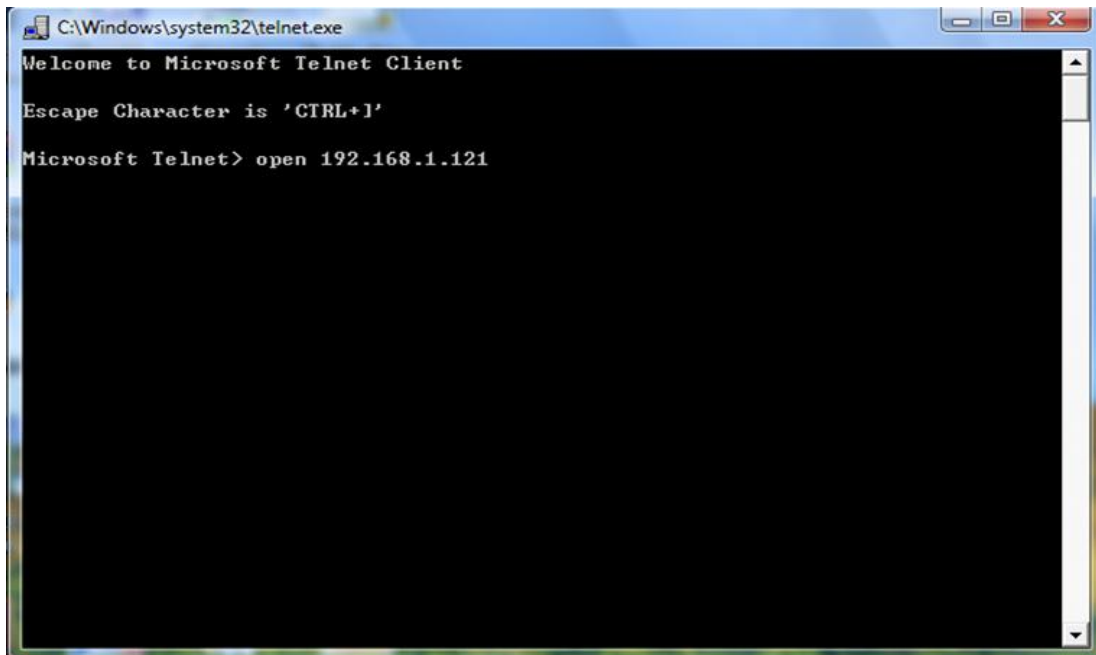

Figure 2-4

Enter the the username and password, interface as shown in figure 2-5 will pop up

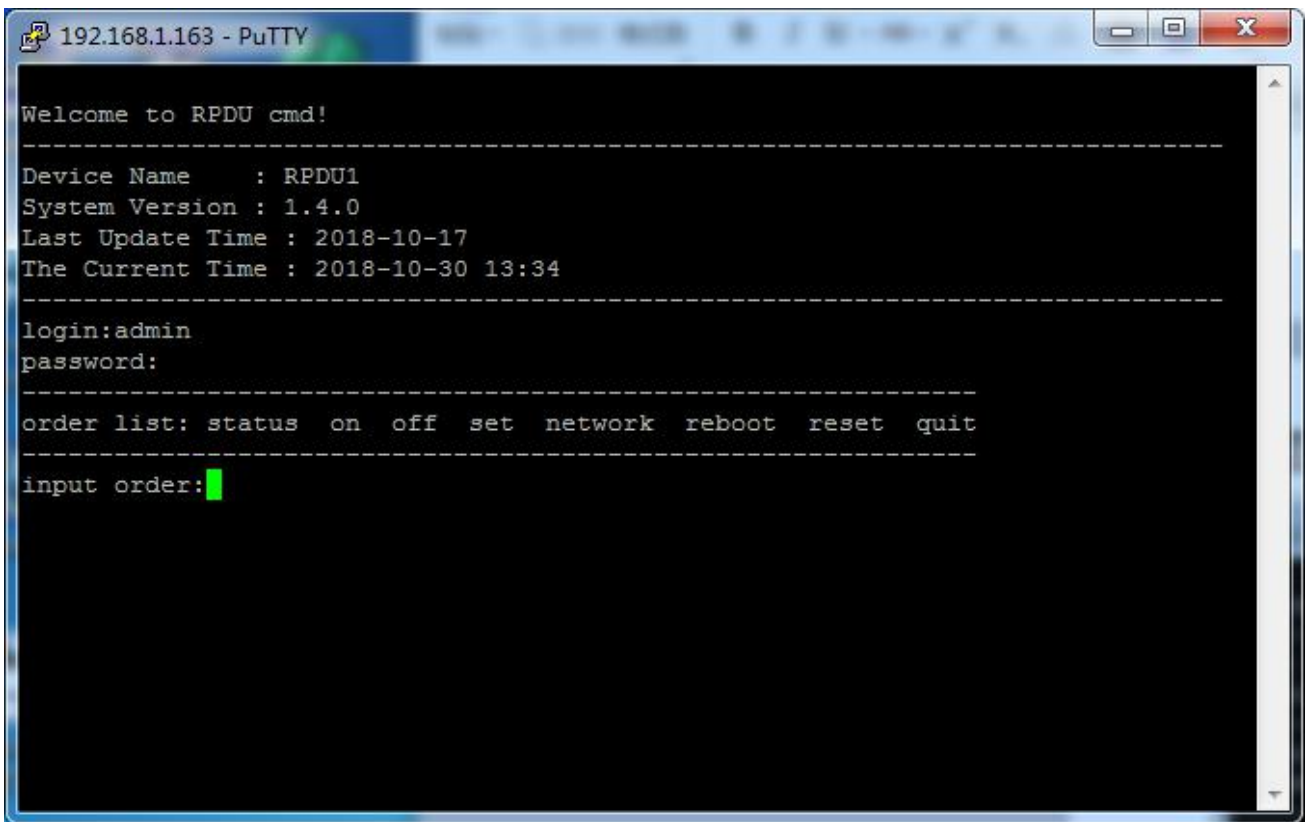

Figure 2-5

2.3.3 “STATUS” command

Input “STATUS” command to view the individual outlet status (including current, on/off state, Max. and Min. current value, kW and kWh) and the overall status (including total current, voltage, kW and kWh).

Command line format: STATUS **【index】【operation】** as illustrated in figure 2-6:

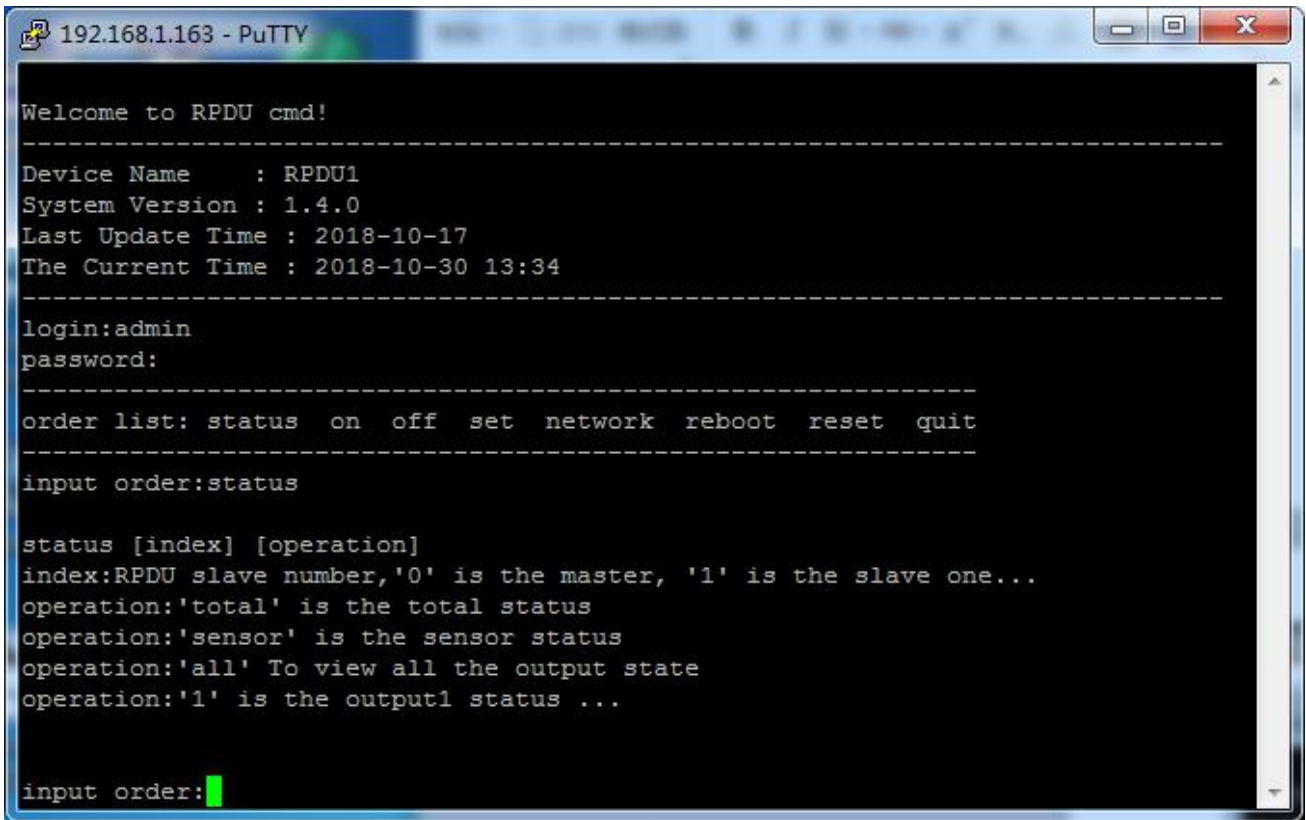
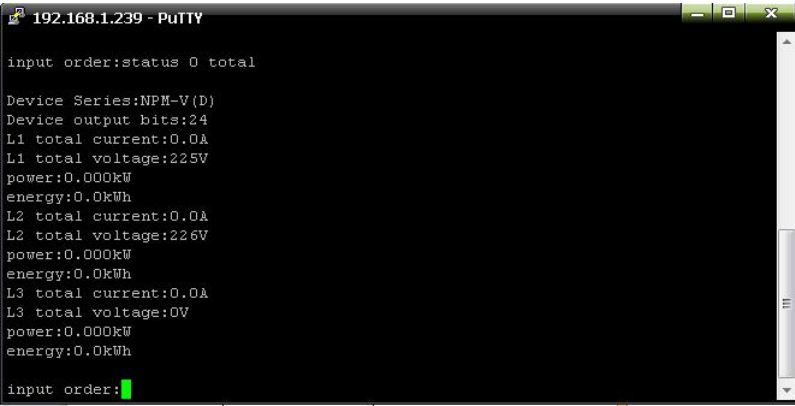
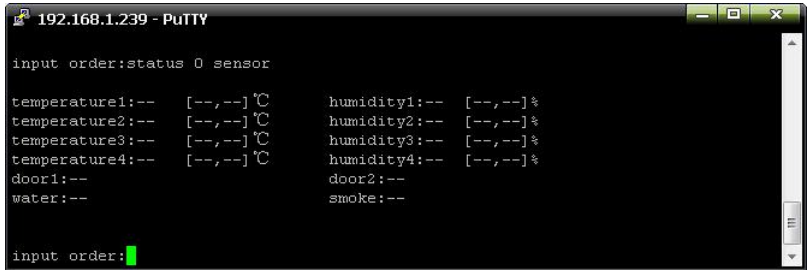

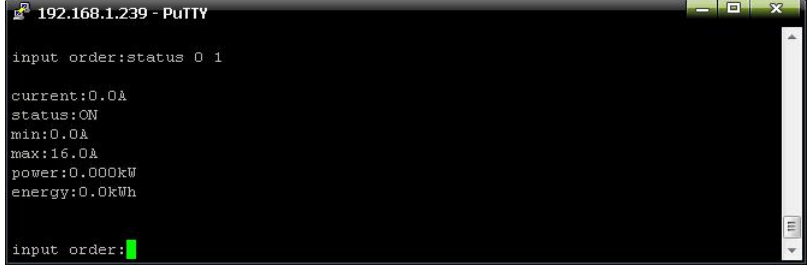

Figure 2-6

【index】 :device mode (0-9, 0 is master, 1-4 is slave) ;

【operation】 :view the device information, details as below:

【operation】	Description
Total	<p>For example:</p>  <p>Enter command line---status 0 total: 0 means the Master(1-4 means Slave 1 to Slave 4), total means the overall status, the above figure shown after input “status 0 total”. The return information will be as picture above</p>

<p>sensor</p>	 <pre> input order:status 0 sensor temperature1:-- [--,--]°C humidity1:-- [--,--]% temperature2:-- [--,--]°C humidity2:-- [--,--]% temperature3:-- [--,--]°C humidity3:-- [--,--]% temperature4:-- [--,--]°C humidity4:-- [--,--]% door1:-- water:-- door2:-- smoke:-- input order: </pre> <p>Enter command line--- status 0 sensor: 0 means the Master unit; 1-4 means the Slave units. The return information will be as picture above</p>
<p>all</p>	 <pre> input order:status 0 all Item Name State Current (A) mincur (A) maxcur (A) Power (kW) energy (kwh) 1 Output1 ON 0.0 0.0 16.0 0.000 0.0 2 Output2 ON 0.0 0.0 16.0 0.000 0.0 3 Output3 ON 0.0 0.0 16.0 0.000 0.0 4 Output4 ON 0.0 0.0 16.0 0.000 0.0 5 Output5 ON 0.0 0.0 16.0 0.000 0.0 6 Output6 ON 0.0 0.0 16.0 0.000 0.0 7 Output7 ON 0.0 0.0 16.0 0.000 0.0 8 Output8 ON 0.0 0.0 16.0 0.000 0.0 9 Output9 ON 0.0 0.0 16.0 0.000 0.0 10 Output10 ON 0.0 0.0 16.0 0.000 0.0 11 Output11 ON 0.0 0.0 16.0 0.000 0.0 12 Output12 ON 0.0 0.0 16.0 0.000 0.0 13 Output13 ON 0.0 0.0 16.0 0.000 0.0 14 Output14 ON 0.0 0.0 16.0 0.000 0.0 15 Output15 ON 0.0 0.0 16.0 0.000 0.0 16 Output16 ON 0.0 0.0 16.0 0.000 0.0 17 Output17 ON 0.0 0.0 16.0 0.000 0.0 18 Output18 ON 0.0 0.0 16.0 0.000 0.0 19 Output19 ON 0.0 0.0 16.0 0.000 0.0 20 Output20 ON 0.0 0.0 16.0 0.000 0.0 21 Output21 ON 0.0 0.0 16.0 0.000 0.0 22 Output22 ON 0.0 0.0 16.0 0.000 0.0 23 Output23 ON 0.0 0.0 16.0 0.000 0.0 24 Output24 ON 0.0 0.0 16.0 0.000 0.0 input order: </pre> <p>Enter command line--- status 0 all, 0 means the Master unit; 1-4 means the Slave units. The return information will be as picture above</p>
<p>Output</p>	<p>For example</p>  <pre> input order:status 0 1 current:0.0A status:ON min:0.0A max:16.0A power:0.000kW energy:0.0kWh input order: </pre> <p>command line---status 0 1: 0 means the Master(1-4 means Slave 1 to Slave 4), 1 means the status of first outlet, the above figure will be displayed after input “status 0 1”</p>

2.3.4 “ON/OFF” command

“ON/OFF” command enable the user to switch on/off the individual outlet or the complete device

Command format: ON/OFF **【index】** **【operation】** as shown in figure 2-7

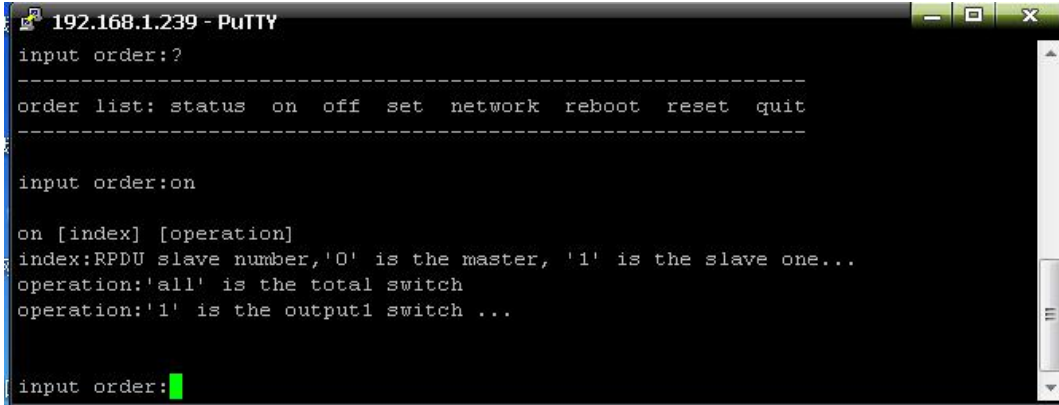
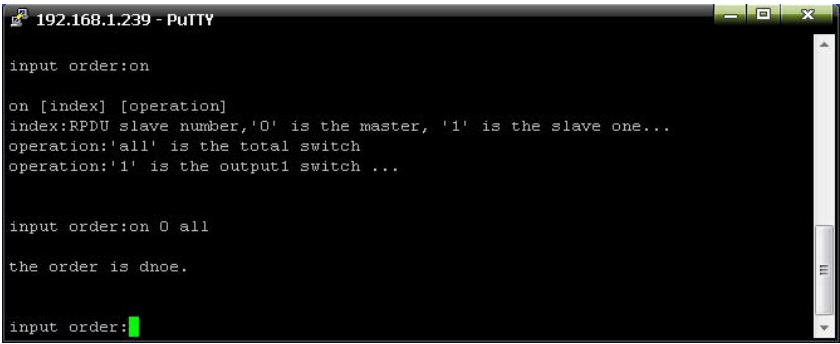
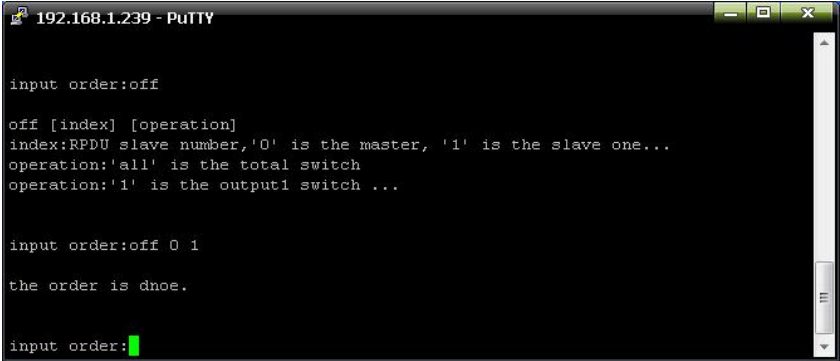

Figure 2-7

【index】 :device mode (0-9, 0 is master, 1-4 is slave) ;

【operation】 :view the device information, details as below:

【operation】	Description
ALL	 <p>Command line---on 0 all means to switch on all outlet from the Master unit</p>
Output	 <p>Command line---off 0 1 on means to switch off the first outlet of the</p>

	Master unit
--	-------------

2.3.5 Set command:

“set” command enable to Set the current of outlet , temperature and humidity minimum and maximum threshold, changing the IP, mask, gateway, dns , dns1;

Command format: set **【index】【operation】** as shown in figure 2-8

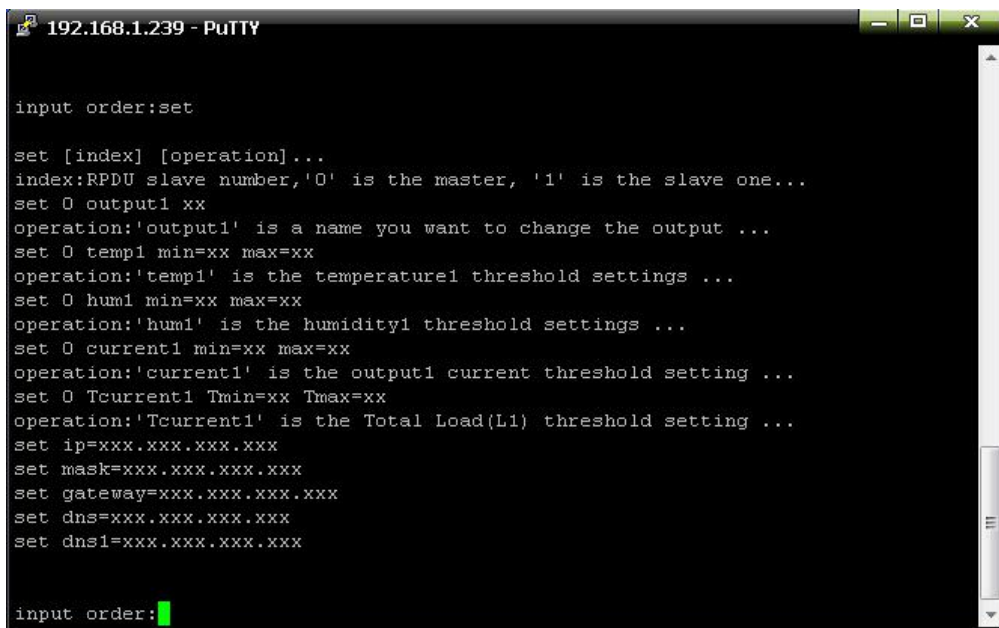
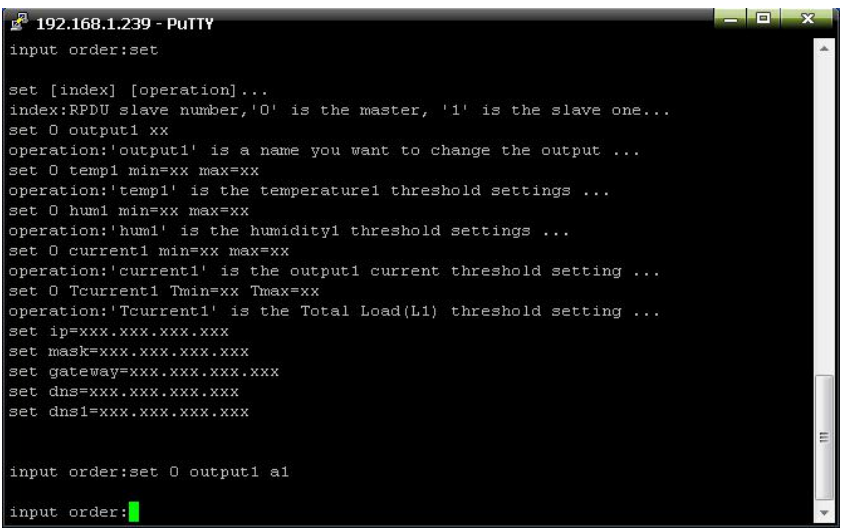
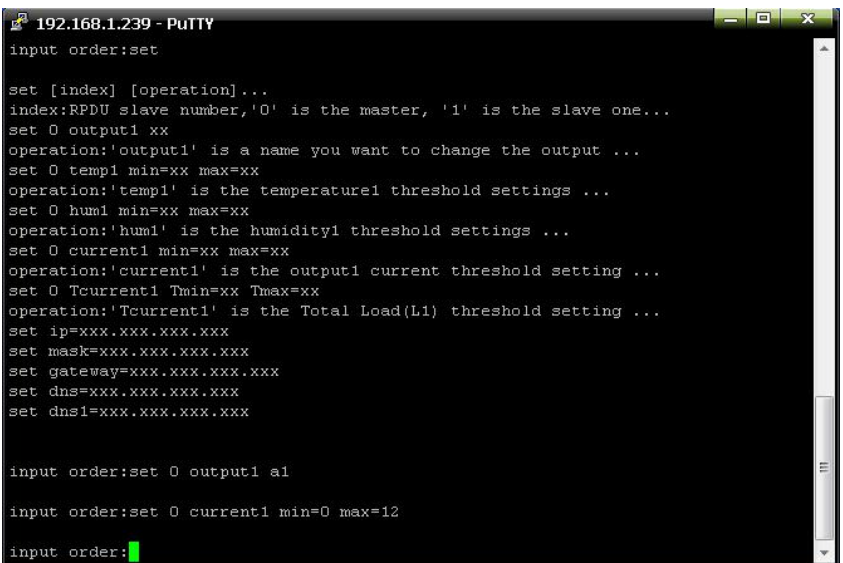

Figure 2-8

【index】 :device mode (0-9, 0 is master, 1-4 is slave) ;

【operation】 :view the device information, details as below:

【operation】	Description
--------------------	--------------------

<p>output</p>	 <p>Command line---set 0 output1 a1 means rename the output 1 as a1</p>
<p>current</p>	 <p>Command line--- set 0 current1 min=0 max=12 means set up the minimum current as 0 and maximum current as 12 for output 1 from Master unit</p>
<p>temperature</p>	

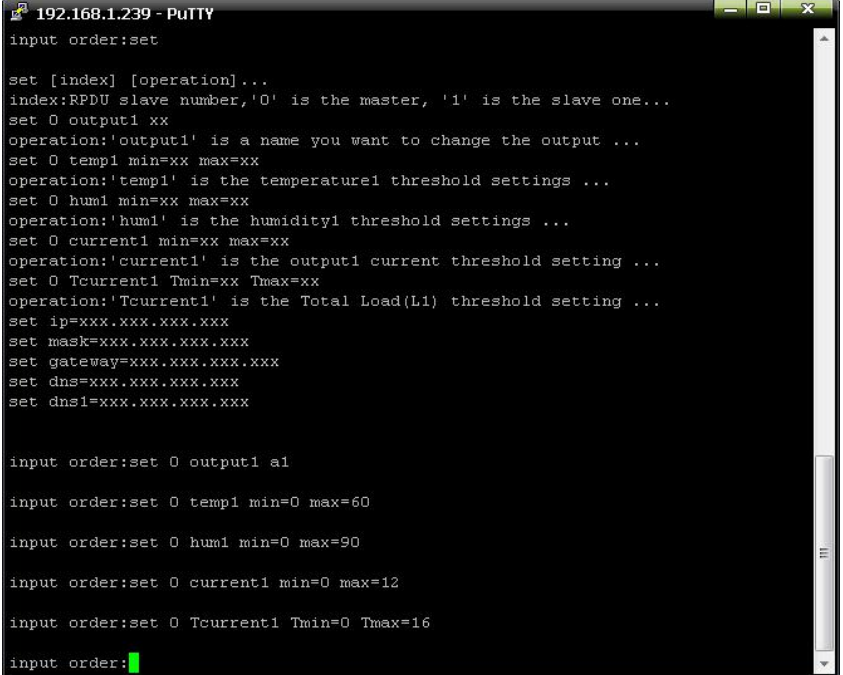
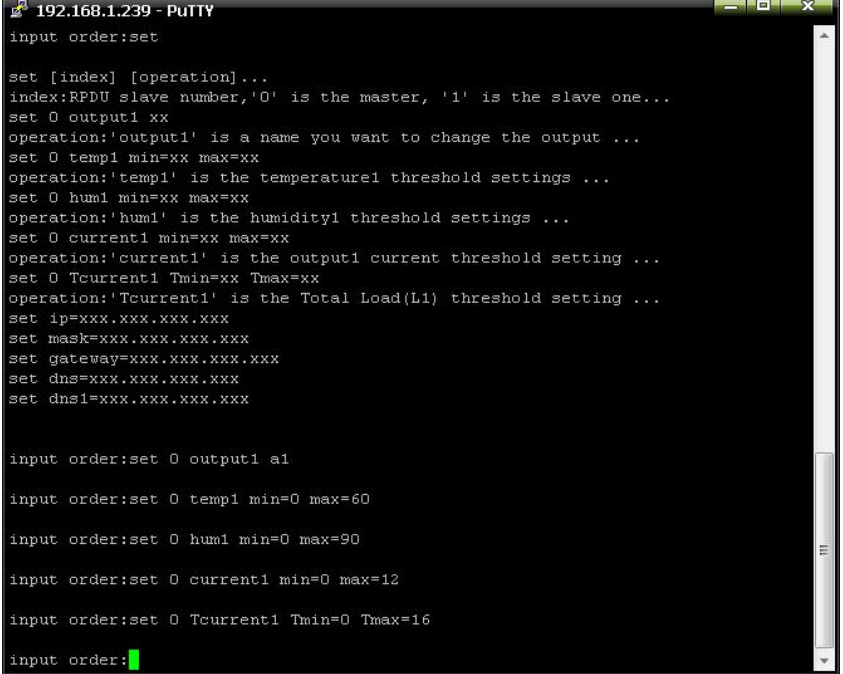
	<p>Command line--- <code>set 0 temp1 min=0 max=60</code> means set the minimum temperature as 0 degree and maximum temperature 60 degree for temperature sensor 1 from master unit</p>
<p>humidity</p>	 <p>Command line---<code>set 0 hum1 min=0 max=90</code> means set the minimum humidity as 0% and maximum humidity as 90% for humidity sensor 1 from Master unit</p>
<p>Tcurrent</p>	 <p>Command line---<code>set 0 Tcurrent1 Tmin=0 Tmax=16</code> means set the minimum current as 0A and maximum current as 16A for total current of phase A from Master unit</p>

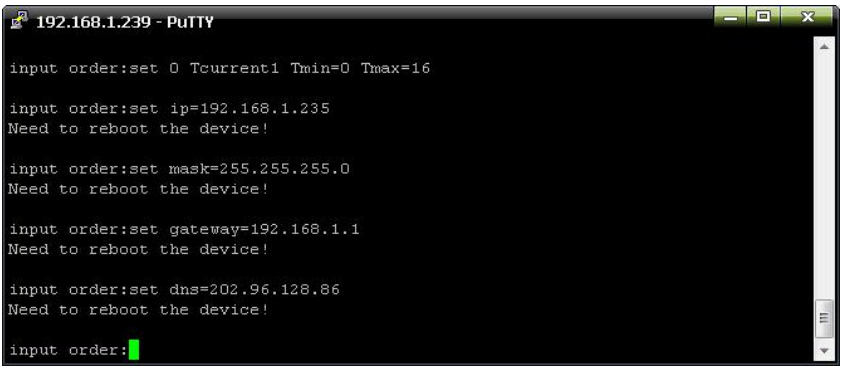
network	 <p>Command line---set 0 ip=192.168.1.223 Means to configure Master network IP address as 192.168.1.223</p>
---------	---

2.3.6 Network command: Check network configuration information, such as IP address, subnet mask, default gateway, main DNS, spare DNS.

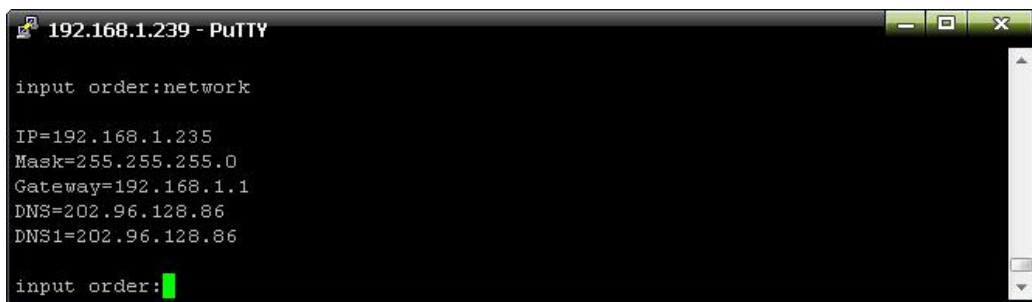

figure 2-9

2.3.7 Reboot command: to restart to device as shown in figure 2-10

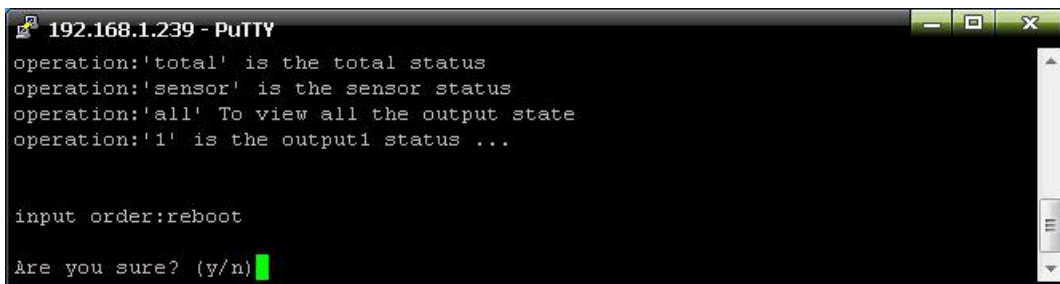

Figure 2-10

After type Y and press Enter, exit the telnet interface, and restart device system; Type n and press Enter to exit the telnet interface

2.3.8: RESET command to restore to factory settings as figure 2-11

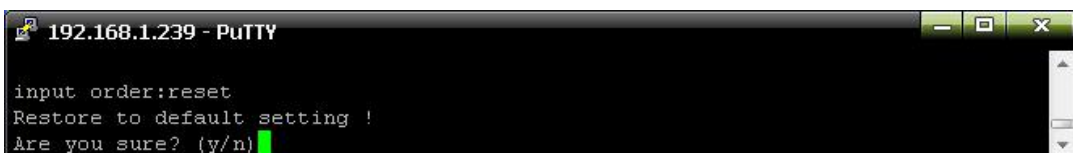

Figure 2-11

2.3.9: QUIT command to quit the telnet client as shown in figure 2-12

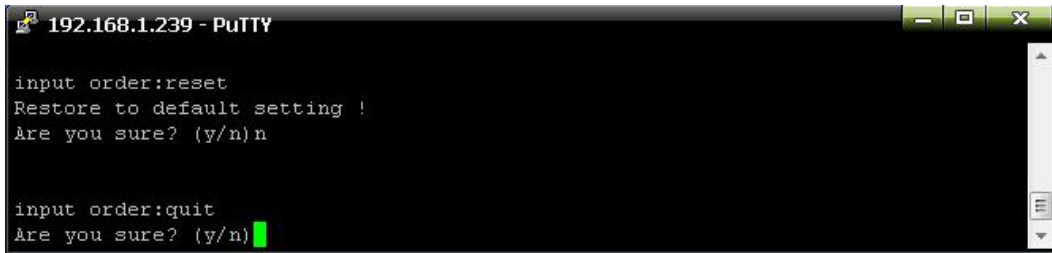

Figure 2-12

Type y and press Enter to quit the Telnet interface. Type n and press Enter to cancel the operation

2.4. MODBUS Access

Please refer to the 《RPDU MODBUS RTU Protocol Instruction》 for the MODBUS access

4. Frequently Asked Questions

4.1. Forget IP address?

A: check on the LCD screen, the first page displays the IP address.

4.2. Fail to send email?

- A:1) Check and confirm the device connected to network and the network works normally.
 2) Check DNS configuration and confirm whether it is successful.
 3) Check and confirm POP, SMTP sever is correct and the same as the sender mailbox sever. Please confirm SMTP port is correct.

4.3. Lost IP

A. Press and hold the RESET button for 6 seconds, Release the RESET button when the device buzz, the device will restart.

5. Technology Parameters

No	Performance parameter	Technical parameter
----	-----------------------	---------------------

1	Input	Rated input voltage	110/220VAC 50/60HZ; 380V~ 50/60 Hz;
		Rated input plug	IEC60309 standard
		Cable specification	16A:3×2.5mm ² 32A:3×6.0mm ² ; 3×16A:5×2.5mm ² 3×32A:5×6.0mm ²
		Cable length	2.5M
		Max. load current	16A, 32A 3×16A, 3×32A
		Overload protector	1P circuit breaker 3P circuit breaker
2	Output	Socket standard	Standard IEC320 C13、C19
		Socket quantity	A Series: 8、16、24、36way; B Series: 8、16、24way; C Series: 8、16、24way; D Series: 8、16、24way;
		Output voltage	110/220VAC 50/60HZ
		Output current	16A、32A 3*16A、3*32A
3	Control ports	Net port	1×RJ45 port
		Daisy chain port	2×RJ45 port
		Software update port	1 ↑ RJ45 port
		Temperature & humidity port	Max 2×RJ11 port (can add more)
		Smoke sensor port	Max 1×RJ11 port (optional)
		Water sensor port	Max 1×RJ11 port (optional)
		Door sensor port	Max 1×RJ11 port (optional)
4	Display	Working state	1×LED
		Power pulse	1×LED

		IP Address, M/S RPDU state, measurement value, alarm state	LCD screen (Resolution: 128×64)
5	Load current display technology requirement	Total current	Full-scale:16A/32A,Accuracy:±1%+0.2 Resolution:200mA, Response:400ms
		Individual load current	Full-scale: 10A/ 16A, Accuracy:±1%+0.1, resolution:100mA, Response:400ms
6	Temperature/ humidity Technology requirement	Temperature	Accuracy:±1℃, Response: 400ms
		Humidity	Accuracy:±5%RH, Response: 400ms
7	Product size	Product size (L×W×H)	X ² ×56×52mm
		Mounting hole	X ³
8	Case color	Color	Black
9	Fittings	Installation bracket	1 set
		Network connection cable	2M, blue
		Serial connection cable	2M, Ivory
		User manual	1 set (CD)
10	Optional fittings	Sensor	Temperature/humidity sensor
			Smoke sensor
			Door sensor
			Water logging sensor
11	Environment	Working Environment	Temperature: 0℃~+45℃ Relative humidity: 5%~95%
		Storage Environment	Temperature: -20℃~+70℃ Relative humidity :0%~95%
12	ROHS	Compliance	

6.Warranty and Service

The RPDU warrants to be free for repairing in two years from the date of purchasing. During this period,

our obligation is limited to repair, replace or return to our company for repair. If the product has been beyond the warrant for repairing time or it has been damaged by accident, negligence or misapplication, you should pay some repair charge.

The above warranty does not apply to the following situation:

- 1、 The damage caused by customers' incorrect or inadequate repair;
- 2、 The damage caused by unauthorized modification or misusing;
- 3、 The damage caused by using out of the product allowed environment.

Repairing Notice:

- 1、 If you want to return the product for repair, please make sure it packed in the bandbox or carton. The damage caused during the transportation is not warranted to repair.
- 2、 Please give a brief description of the repairing product about the problem and its operating process.
- 3、 The customer should pay for the returning freight, all the tariffs and taxes.
- 4、 Please write down your name, address and the telephone number by which we can contact you at anytime.