

### Overview

### HPE 6Gb/s SAS BL Switch for BladeSystem

The HPE 6Gb/s SAS BL Switch for HPE BladeSystem c-Class enclosures is an integral part of HPE direct connect SAS storage, enabling a shared SAS storage solution. The SAS architecture combines a HPE Smart Array P711m, P712m (with cache module), P721m or P731m Controller in each server and 6Gb/s SAS BL switches connected to supported HPE storage enclosures for SAS storage. The 6 Gb/s SAS BL Switch contains an embedded Virtual SAS Manager (VSM) GUI & CLI interface used to zone, monitor, and update SAS fabric devices.

The 6 Gb/s SAS BL Switch enables two external SAS storage solutions for BladeSystem servers:

- **Shared SAS:** The 6 GB/s SAS BL Switch can be used to access shared SAS storage provided by the P2000 G3 SAS array system. A HPE Smart Array P711m, P712m (with cache module) , P721m or P731m Controller installed in each server acts as a pass-through, with RAID functionality for shared SAS storage provided by the P2000 G3 SAS array system. The P2000 G3 SAS array system creates a shared storage environment where more than one blade server can access a storage logical unit.
- **Zoned Direct Attached Storage:** Use the Virtual SAS Manager of the 6Gb SAS BL Switch to zone groups of drive bays in the MDS600, D2000 (D2600/D2700) or D3000 (D3600/D3700) and assign them to individual blade server bays. A HPE Smart Array P711m /P721m/P731m Controller installed in the server provides RAID functionality for the group of SAS and SATA drives that have been zoned to that server. The logical drives provided by the P711m /P721m/P731m Controller will appear as local drives to that individual server. The P711m/P721m/P731m offers load balancing and fail over anytime dual paths to dual-ported SAS drives are available when using two HPE 6Gb SAS BL Switches cabled to a MDS600 configured with the HPE MDS600 Dual I/O Module Option Kit or to a D2600/D2700 or D3600/D3700 or D6000 configured with dual IO module option kit.

For more information on 6Gb/s SAS storage solutions for HPE BladeSystem, see: <http://www.hp.com/go/directconnect>.

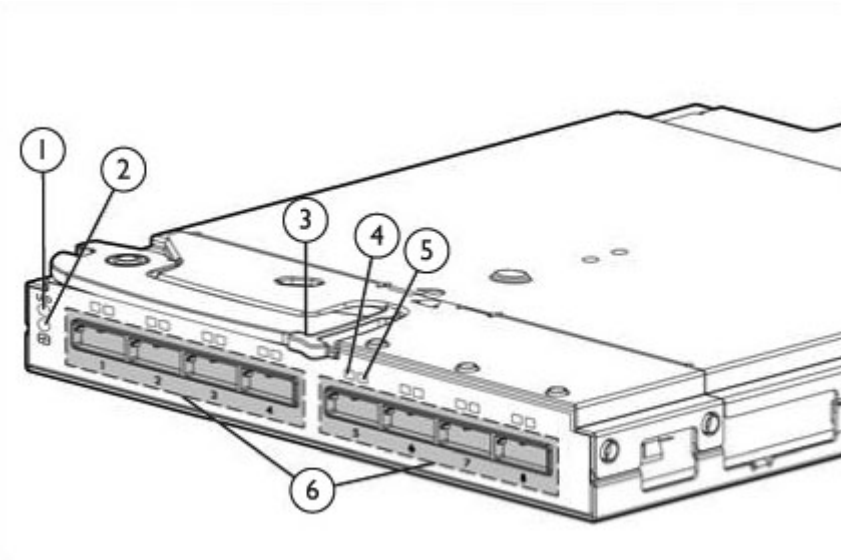

1. Unit ID LED

- Solid Blue-Being identified.
- Blinking Blue-Firmware is being updated

4. Link LED

- Solid green-A link between switch and storage enclosure is established.

## Overview

- Off-Normal.
  - Blinking green-There is activity on the established link.
  - Off-There is no link between the server and storage.
2. Health LED
- Solid Green-Healthy.
  - Blinking Amber-There is a problem with the switch.
  - Off-Not powered up.
3. Release button for the ejector handle
5. Fault LED
- Off-Normal.
  - Solid Amber-There is a link error detected by the switch. Service either the Switch, SAS Cable, or attached Device.
6. Mini-SAS ports containing 4x 6G SAS links (attach to external storage enclosures)

## What's New

- Support for D3000 enclosures
- Support for MSA2040 SAS storage

## At A Glance

- HPE Secure Encryption support when using a HPE Smart Array P731m Controller
- Hot Pluggable 6Gb/s SAS Switch for HPE BladeSystem
- Sixteen internal blade bay ports containing 2x 6Gb/s SAS links
- Eight external Mini-SAS ports containing 4x 6Gb/s SAS links
- Use Mini-SAS cables to connect to P2000 G3 SAS array system enclosures for shared SAS storage or MDS600 or D2000 enclosures for zoned direct attached SAS storage
- Dual Domain direct attached SAS architecture supported with MDS600, D2000 or D3000.
- Supported by c3000 and c7000 BladeSystem enclosures (see supported options list for specific SKUs)
- SAS fabric Topology View allows users to easily view their SAS fabric connectivity.
- View non-zoned hard drive information (capacity, RPM, link rate, etc.) while creating zone groups.
- Advanced tape support - port splitting allows up to 4 tape devices to attach to a single SAS switch port.
- SAS switch web interface allows the capture and deployment of configuration scripts.
- Full SNMP support for SAS switch and attached storage enclosures.
- Detailed diagnostic information provided for MDS600 field issues

For detailed deployment information, see the HPE direct connect external SAS storage for HPE BladeSystem external SAS storage deployment guide for 6Gb at:

<http://bizsupport1.austin.hp.com/bc/docs/support/SupportManual/c02775615/c02775615.pdf>

## Models

<b>6Gb/s SAS Switch</b>	HPE 6Gb SAS Switch Single Pack for HPE BladeSystem c-Class	BK763A
	HPE 6Gb SAS Switch Dual Pack for HPE BladeSystem c-Class	BK764A

## Solutions Components

### Configuration Rules: 6Gb/s SAS Switch:

- The SAS Switch is supported by all c3000 and selected c7000 BladeSystem enclosures (see the Related Items section for the list for specific SKUs). Installation of the 6 Gb/s SAS BL Switch in up to 6 interconnect bays in the c7000 and up to 2 interconnect bays in the c3000 is supported.
- (2) SAS Switches are required in the same c-Class enclosure interconnect bay row for redundancy. Single switch configurations are supported as non-redundant.
- **NOTE: Cascading (“daisy-chaining”) multiple arrays from a single 6 GB/s SAS Switch port is not a supported configuration.**

Use the embedded Virtual SAS Manager GUI or CLI interface to zone switch ports to server bays. Supported Internet browser versions: Microsoft Internet Explorer 6.0/7.0, Mozilla Firefox 3.

### Related Items

#### P2000 G3 SAS

HP P2000 G3 SAS MSA Dual Controller LFF Array System	AW593B
HP P2000 G3 SAS MSA Dual Controller SFF Array System	AW594B

#### MDS600

HP MDS600 Dual I/O Module Option Kit	AP763A
--------------------------------------	--------

#### D6000

HPE D6000 Dual I/O Module Disk Enclosure	QQ695A
--	--------

#### D2000

HP D2600 Disk Enclosure	AJ940A
HPE D2700 Disk Enclosure	AJ941A

**NOTE: For MDS600 6Gb host connectivity, P711m firmware 5.32 or higher, 6Gb BL SAS switch firmware 2.0.1.0 or higher and MDS600 firmware 3.44 are required.**

**NOTE: For D2600/D2700 support in Blade configuration, P711m firmware 5.32 or higher, 6Gb BL SAS switch firmware 2.0.1.0 or higher and D2600/D2700 firmware 1.34 or higher are required**

#### D3000 Enclosures

HP D3600 Enclosure	QW968A
HP D3700 Enclosure	QW967A

**NOTE: For D3600/D3700 support in Blade configuration, P721m firmware 5.32 or higher, 6Gb BL SAS switch firmware 2.0.1.0 or higher and D3600/D3700 firmware 1.34 or higher are required**

#### Smart Array

HP Smart Array P712m/256 6Gb 2-ports Int/2-ports Ext Mezzanine SAS Controller	488348-B21
HPE Smart Array P711m/1G 6Gb FBWC 4-ports Ext Mezzanine SAS Controller	513778-B21

HP Smart Array P721m/2GB FBWC 6Gb 4-ports Ext Mezzanine SAS Controller	650072-B21
HP Smart Array P721m/512 FBWC 6Gb 4-ports Ext Mezzanine SAS Controller	655636-B21
HPE Smart Array P741m/2GB FBWC 12Gb 4-ports Ext Mezzanine SAS Controller	726782-B21

#### SAS cable

HPE External Mini SAS 2m Cable	407339-B21
--------------------------------	------------

NOTE:NOTE: Use this cable to connect HPE P2000 G3 SAS,MDS600, D2000

#### SAS cables for tape

HPE SAS Min-Min 1x-2M Cable Assembly Kit	AE470A
--	--------

NOTE:NOTE: Use this cable to connect HPE SAS external tape devices

## Solutions Components

<b>drives</b>	HPE SAS MIN-MIN 1X-4M Cable Assembly Kit	AE465A
	NOTE:NOTE: Use this cable to connect HPE SAS external tape devices	
	HPE StoreEver 2m External Mini-SAS to 4x1 Mini-SAS Cable	AN975A
	<b>NOTE: Use this cable to connect HPE MSL SAS Tape Libraries</b>	
	HPE StoreEver 4m External Mini-SAS to 4x1 Mini-SAS Cable	AN976A
	NOTE:NOTE: Use this cable to connect HPE MSL SAS Tape Libraries	
	<b>For more information on tape products, see: <a href="http://www.hp.com/go/tape">http://www.hp.com/go/tape</a></b>	
<b>c -Class BladeSystem Enclosures</b>	HP BLc7000 Enclosure with 1 Phase 2 Power Supply 4 Fan ROHS ICE License	507014-B21
	HP BLc7000 Enclosure with 1 Phase 6 Power Supply 10 Fan FI ROHS ICE License	507015-B21
	HP BLc7000 Enclosure with 3 Phase 6 Power Supply 10 Fan INTL ROHS ICE License	507016-B21
	HP BLc7000 Enclosure with 3 Phase 6 Power Supply 10 Fan ENG ROHS ICE License	507017-B21
	HPE BLc7000 Platinum Enclosure with 1 Phase 6 Power Supplies 10 Fans ROHS 16 Insight Control LTU	681842-B21
	HPE BLc7000 Platinum Enclosure w/ 1 Phase 2 Power Supplies 4 Fans ROHS Trial Insight Control License	681840-B21
	HPE BLc7000 Platinum Enclosure with 1 Phase 6 Pwr Supplies 10 Fans ROHS 16 OneView Licenses	763850-B21
	HPE BLc3000 Platinum Enclosure with 4 AC Power Supplies 6 Fans ROHS 8 Insight Control Licenses	696908-B21
	HPE BLc3000 Platinum Enclosure with 4 AC Power Supplies 6 Fans ROHS Trial Insight Control License	696909-B21
	HP BLc3000 Enclosure with 4 AC Power Supplies 6 Fan Full ICE License	508664-B21
	HP BLc3000 Enclosure with 4 AC Power Supplies 6 Fan Trial ICE License	508665-B21
	HP BLc3000 Enclosure with 2 AC Power Supplies 4 Fan Trial ICE License	536841-B21

### Warranty

This product is covered by a global limited warranty and supported by HPE Services and a worldwide network of Hewlett Packard Enterprise Authorized Channel Partners. Hardware diagnostic support and repair is available for three years from date of purchase. Support for software and initial setup is available for 90 days from date of purchase. Additional support may be covered under the warranty or available for an additional fee. Enhancements to warranty services are available through HPE Pointnext operational services or customized service agreements.

**NOTE: Server Blade Interconnect Limited Warranty includes 1 year Parts, 1 year Labor, 1-year on-site support. Additional information regarding worldwide limited warranty and technical support is available at: <http://h18004.www1.hp.com/products/servers/platforms/warranty/index.html>**

HPE services provide total care and support expertise with committed response designed to meet your IT and business needs.

## Service and Support and Warranty Information

### HPE Pointnext operational services

Scalable, Flexible, Dependable. Like your storage.

Your storage is evolving. Get scalable support that evolves with it. HPE Pointnext operational services is an easy-to-buy, easy-to-use portfolio of packaged services covering your lifecycle needs. You can rely on our highly skilled, HPE certified professionals to offer a breadth of expertise across leading storage technologies, and work side by side with you for optimal results. Push services beyond expectations and choose support that meets the changing needs of your business with the same reliability, scalability and flexibility you demand of your storage.

Protect your business beyond the warranty

Standard warranty protects against product defects and some causes of downtime. HPE Pointnext operational services helps you proactively guard against unplanned downtime which can reduce your productivity and profitability. By using a standard approach to warranty uplifts, such as HPE Pointnext operational services, customers can be more sure of consistency of operations for both mission-critical and standard business computing.

Extending warranties with HPE Pointnext operational services

The key to normalizing the warranty of combined solutions-is making service uplift simple: HPE Pointnext operational services. This portfolio of predefined packages, extending across the entire IT lifecycle, offering consulting, education, technical support, optimization, risk assessment, and more. It's entirely flexible allowing customers to extend the cover to the precise level of support required. Customer's standard hardware warranty, for example, can be upgraded to next-business-day response, to same-day coverage, or even to a committed six-hour call-to-repair service available 24 hours every day of the week.

- Provide consistent, predictable levels of support across your entire department or business
- Give you direct access to proven technical and problem-solving expertise
- Offer a choice of response-time and repair-time commitments
- Are available whenever and wherever you do business

For many products, post-warranty HPE Pointnext operational services are available when your original warranty has expired. Choose the support levels that meet your business requirements, from basic to mission-critical. <http://www.hp.com/services/storage>

**NOTE: Care Pack Services availability may vary by product and country.**

### Recommended Services

Hewlett Packard Enterprise recommends Proactive Care for your BladeSystem servers, enclosures and components to prevent problems with proactive advice and assistance, resolve issues and rapidly recover by connecting to The Hewlett Packard Enterprise enhanced call experience and advanced technical expertise.

### HPE Installation and Startup Service for HPE BladeSystem c-Class Infrastructure (OS + ICE)

HPE Installation and Startup Service for HPE BladeSystem c-Class Infrastructure (OS + ICE)

## Service and Support and Warranty Information

Product Number	Product Name	Service Name	Care Pack Services Product # and Band	Alternate Care Pack Services Product #
BK763A	HPE 6Gb/s SAS BL Switch (CTO Only)	3-Year HPE Support Plus 24	HA110A3-9LZ	-
-	-	HPE Installation and Startup Service for HPE BladeSystem c-Class Infrastructure	HA114A1-5N9	UF817E
BK764A	HPE 6Gb/s SAS BL Switch - Dual Pack	3-Year HPE Support Plus 24	HA110A3-4CS	-
-	-	HPE Installation and Startup Service for HPE BladeSystem c-Class Infrastructure	HA114A1-5N9	UF817E

### Related Services

#### Services that will enhance the user experience in many product deployments.

##### HPE SAN Solution Service

Get your SAN implementation right - right from the start.

Storage has become essential to the growth and agility of your business. That's why choosing an HPE SAN as your data management solution is a smart business decision. But your SAN can deliver the results you need only if it is implemented correctly and integrated with your business.

SAN installation, startup, and integration call for specialized expertise in planning and design, hardware configuration, network software installation, and operability verification. Your SAN needs to be configured for high performance and availability. And it needs to be integrated with your applications, management environment, and business processes.

##### HPE Data Migration Service

Minimize the risks involved in transferring data to your HPE Storage SAN.

You need to move your critical enterprise data to your new HPE Storage SAN platform. And you need to accomplish that without losing data. And without interrupting your ongoing business operations.

HPE Data Migration Service helps you lessen the risk of data loss, minimize threats to data integrity, and avoid productivity-sapping performance slowdowns during data transport. A highly experienced HPE Services storage specialist works with you to rapidly and securely migrate mission-critical business information across your data center or around the globe - regardless of the complexity of your environment.

##### HPE Proactive BladeSystem Service

HPE Proactive BladeSystem Service helps you improve the ongoing management and utilization of your HPE blade technology and tools in order to provide the reliability and the cost-effective performance your business expects. It covers HPE blade servers, storage, network and SAN devices, as well as the HPE blade management software suite included in the HPE blade enclosure. This proactive service leverages HPE's global delivery organization with its experienced technical experts who help IT organizations manage and maintain their IT infrastructures to be more cost-effective and change-ready.

## Service and Support and Warranty Information

Product Number	Product Name	Service Name	Care Pack Services Product # and Band	Alternate Care Pack Services Product #
-	-	HPE SAN Solution Service	Contact your Hewlett Packard Enterprise sales rep or Channel Partner for assistance	Contact your Hewlett Packard Enterprise sales rep or Channel Partner for assistance
-	-	HPE Data Migration Service	Contact your Hewlett Packard Enterprise sales rep or Channel Partner for assistance	Contact your Hewlett Packard Enterprise sales rep or Channel Partner for assistance
-	-	HPE Proactive BladeSystem Service	HE805A1	Contact your Hewlett Packard Enterprise sales rep or Channel Partner for assistance

### eSupport

HPE eSupport is a portfolio of technology-based services that assist you with managing your business environment - from the desktop to the data center.

#### Support Portal

The HPE support portal provides one-stop access to the information, tools and services you need to manage the daily operations of your IT environment.

Features include:

- Access to self-solve tools (including search technical knowledge base)
- Efficient logging and tracking of support cases
- Collaboration with other business and IT professionals
- Download of patches and drivers
- Access to diagnostic tools
- Proactive notification of relevant information

Access to certain features of the support portal requires an HPE service agreement. To access the support portal, visit: <http://www.hp.com/support>

#### Remote Support Technology (RST)-HPE Remote Support Pack

Taking a more proactive approach to IT support, the HPE Remote Support pack plug-in module easily integrates with HPE Systems Insight Manager to provide a powerful, unified "single pane of glass" solution for onsite and remote management.

HPE Remote Support Pack enhances HPE Systems Insight Manager with intelligent event diagnosis plus the automatic submission of hardware event notifications securely to HPE support, including acknowledgment and status returns. It adds remote configuration collections to allow the delivery of assessment and proactive services for your SAN storage and HP-UX environments.

### Customer Technical Training

Consider education as an integral part of your strategy to get the best return on investment for your HPE storage solution. Hewlett Packard Enterprise offers a variety of training courses on storage software, networking, archiving and disk storage systems. Our classes are available in many delivery modalities from traditional instructor-led courses at one of our 80 training centers worldwide to on-site training customized to your needs or online. <http://www.hp.com/learn/storage>

---

## Service and Support and Warranty Information

---

**HPE Services Awards**

HPE Services continues to be recognized for service and support excellence by customers, partners, industry organizations and publications around the world. Recent honors and award reflect our services team's dedications, technical expertise, professionalism and uncompromising commitment to customer satisfaction. For a list of all our awards, please visit:

<http://h20129.www2.hp.com/services/cache/77318-0-0-225-121.html>.

---

**Additional Services Information**

For more information about HPE Pointnext operational services for Storage, please visit:

<http://www.hp.com/hps/storage>

If you have specific questions, contact your local HPE representative. Contact information for a representative in your area can be found at "Contact HPE" <http://www.hp.com>



## Technical Specifications

<b>General Specifications</b>	<b>Communications</b>	SSH, Telnet, HTTP, RS232 using OA CLI and SNMP		
	<b>Processor</b>			
<b>Power and Environmental Specifications</b>	<b>Data path</b>	6Gb/s SAS x2 to Server Blade 6Gb/s SAS x4 to external storage enclosures		
	<b>Dimensions (L xW)</b>	Single-wide 1.1" tall, 7.584" wide, and 10.548" deep		
	<b>Weight</b>	5.2 lbs		
	<b>Operating</b>	Temperature	10° to 35°C (50° to 95°F) at sea level with an altitude derating of 1.0°C per every 305m (1.8°F per every 1000ft) above sea level to a maximum of 3050m (10,000ft), no direct sustained sunlight. Maximum rate of change is 10°C/Hr (18°F/Hr ). The upper limit may be limited by the type and number of options installed.	
		Humidity (non-condensing)	10 to 90% relative humidity (Rh), 28°C (82.4°F) maximum wet bulb temperature, non-condensing.	
	<b>Power requirement</b>	40Watts (Max), 3Watts (Min)		
<b>Emissions</b>				
<b>Classifications</b>				

## Summary of Changes

Date	Version History	Action	Description of Change
23-Oct-2017	Version 16	Added	Care Pack naming and Service and Support- Parts and Materials updated.
17-Jun-2016	From Version 14 to 15	Changed	Updated configuration details and supported Smart Array Controllers
05-Dec-2014	From Version 13 to 14	Changed	Changes on the Solution Components Section; Removed Obsolete SKUs
18-Apr-2014	From Version 12 to 13	Changed	Changes made in Service and Support section.
28-Feb-2014	From Version 11 to 12	Changed	Updated the following: Overview - added P731m Controller; At A Glance; Related Items - added MSA2040 SAS, C8S54A, C8S55A, C8S56A and C8S57A; Smart Array - added P731m, 698535-B21 and 698536-B21;
08-Nov-2013	From Version 10 to 11	Changed	Updated the following: Overview; What's New; Solution Components - related items - added MSA 2040 SKUs
10-Sep-2013	From Version 9 to 10	Changed	Product descriptions were revised.
29-Mar-2013	From Version 6 to 9	Changed	Overview: Updated What's New with: Support for HPE BladeSystem Platinum Enclosure  Solutions Components: Updated Configuration Rules and c -Class BladeSystem Enclosures sections.
28-Sep-2012	From Version 5 to 6	Changed	Changes were made in Overview, Solutions Components and Service and Support, HPE Care Pack and Warranty Information sections.
04-Nov-2011	From Version 4 to 5	Changed	Updated the following: What's New - firmware version
23-Sep-2011	From Version 3 to 4	Changed	Updated the following: Overview; What's new; At a Glance; Models; Configuration rules; Related Items; Service and Support; Technical Specifications - Communications Processor
09-Jun-2011	From Version 2 to 3	Removed	Removed "StorageWorks" throughout the document.
27-May-2011	From Version 1 to 2	Changed	Updated the following sections: minor typos corrected; at a Glance; Solution Components - configuration rules added RoHS note; Related Items replaced MSA2000sa with P2000 G3 SAS and updates controller names; Tape Drive list completely redone; c-Class Blade Enclosures - 4 SKUs added; service and warranty - new part numbers for the Installation and Startup Service for BladeSystems c-Class infrastructure.

## Summary of Changes



**Sign up for updates**



**Hewlett Packard  
Enterprise**

---

© Copyright 2017 Hewlett Packard Enterprise Development LP. The information contained herein is subject to change without notice. The only warranties for Hewlett Packard Enterprise products and services are set forth in the express warranty statements accompanying such products and services. Nothing herein should be construed as constituting an additional warranty. Hewlett Packard Enterprise shall not be liable for technical or editorial errors or omissions contained herein.

Windows and Microsoft are registered trademarks of Microsoft Corp., in the U.S.

For hard drives, 1 GB = 1 billion bytes. Actual formatted capacity is less.

c04123176 - 13960 - Worldwide - V16 - 23-October-2017