

What You Make Possible



Cisco Nexus 7000 Switch Architecture

BRKARC-3470

Session Goal

- To provide a thorough understanding of the Cisco Nexus™ 7000 switching architecture, supervisor, fabric, and I/O module design, packet flows, and key forwarding engine functions
- This session will examine only the latest additions to the Nexus 7000 platform
- This session will not examine NX-OS software architecture or other Nexus platform architectures



What is Nexus 7000?

Data-center class Ethernet switch designed to deliver high-availability, system scale, usability, investment protection



Agenda

- Chassis Architecture
- Supervisor Engine and I/O Module Architecture
- Forwarding Engine Architecture
- Fabric Architecture
- I/O Module Queuing
- Layer 2 Forwarding
- IP Forwarding
- Classification
- NetFlow
- Conclusion

Nexus 7000 Chassis Family

Nexus 7010



Nexus 7018

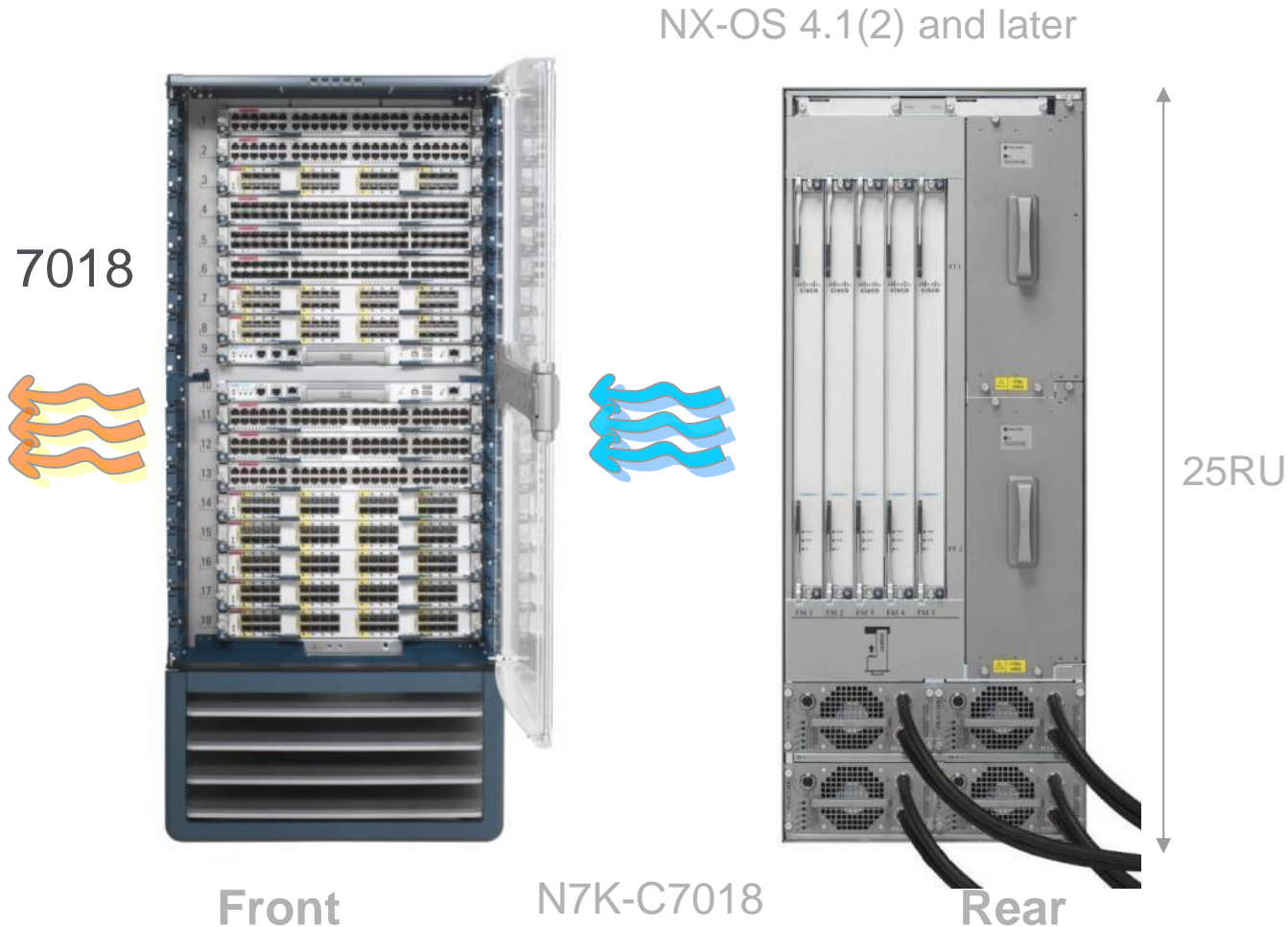

Nexus 7009

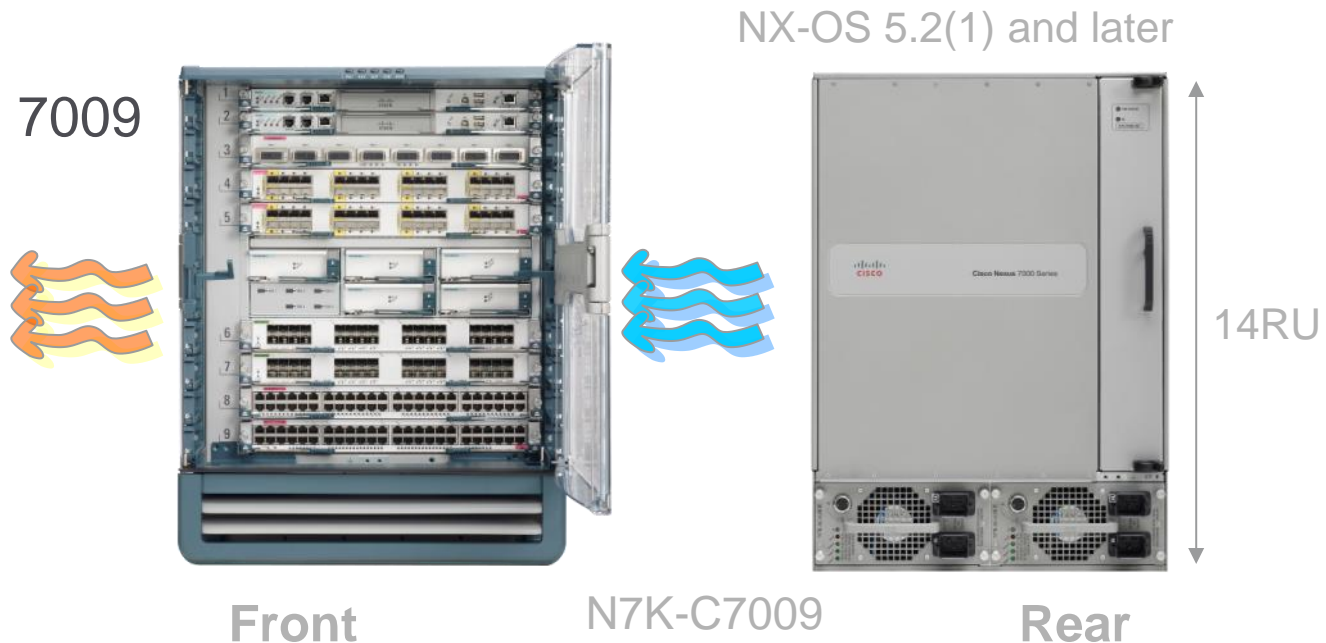

Nexus 7004

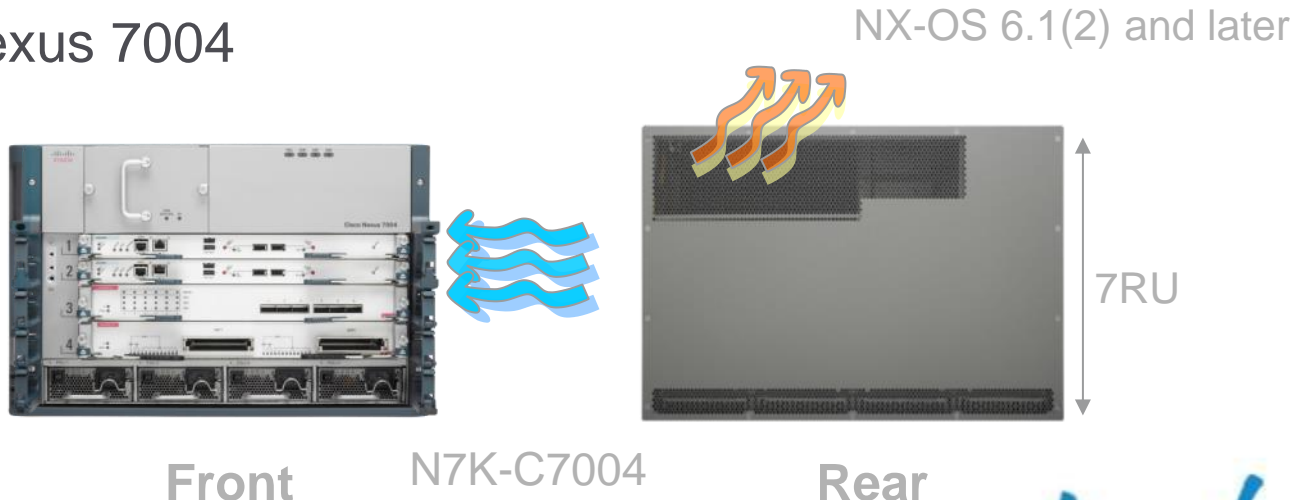

Nexus 7004 Chassis



- 4 slot chassis – 2 payload slots, 2 supervisor slots
- No fabric modules – I/O modules connect back-to-back
- Side-to-back airflow
- 3 X 3000W power supplies (AC or DC)
- All FRUs accessed from chassis front
- Supports Sup2 / 2E only
- Supports M1L, M2, F2, F2E modules
 - No support for M1 non-L, F1 modules

Key Chassis Components

- Common components:
 - Supervisor Engines
 - I/O Modules
 - Power Supplies (except 7004)
- Chassis-specific components:
 - Fabric Modules
 - Fan Trays

Agenda

- Chassis Architecture
- **Supervisor Engine and I/O Module Architecture**
- Forwarding Engine Architecture
- Fabric Architecture
- I/O Module Queuing
- Layer 2 Forwarding
- IP Forwarding
- Classification
- NetFlow
- Conclusion

Supervisor Engine 2 / 2E

- Next generation supervisors providing control plane and management functions

Supervisor Engine 2	Supervisor Engine 2E
Base performance	High performance
One quad-core 2.1GHz CPU with 12GB DRAM	Two quad-core 2.1GHz CPU with 32GB DRAM

- Second-generation dedicated central arbiter ASIC
 - Controls access to fabric bandwidth via dedicated arbitration path to I/O modules
- Interfaces with I/O modules via 1G switched EOBC

N7K-SUP2/N7K-SUP2E

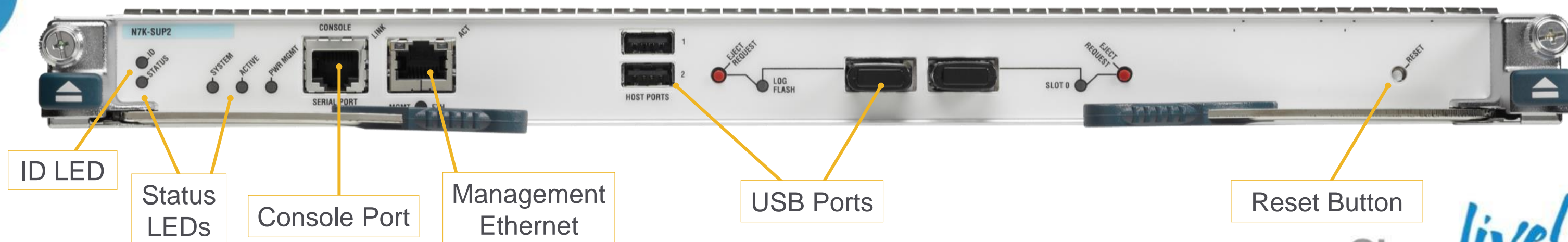

Nexus 7000 I/O Module Families

M Series and F Series

- M Series – L2/L3/L4 with large forwarding tables and rich feature set



- F Series – High performance, low latency, low power with streamlined feature set

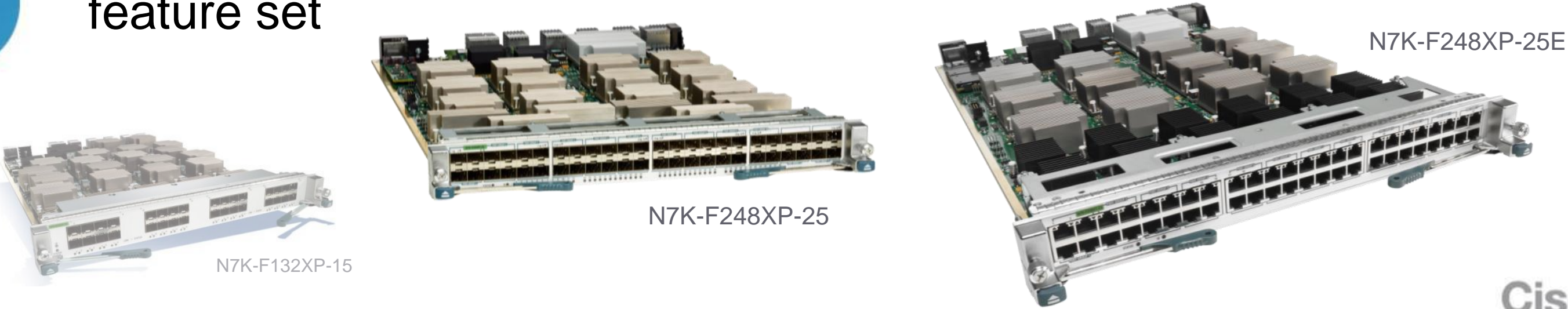

24-Port 10G M2 I/O Module

N7K-M224XP-23L

- 24-port 10G with SFP+ transceivers
- 240G full-duplex fabric connectivity
- Two integrated forwarding engines (120Mpps)
 - Support for “XL” forwarding tables (licensed feature)
- Distributed L3 multicast replication
- 802.1AE LinkSec on all ports

N7K-M224XP-23L

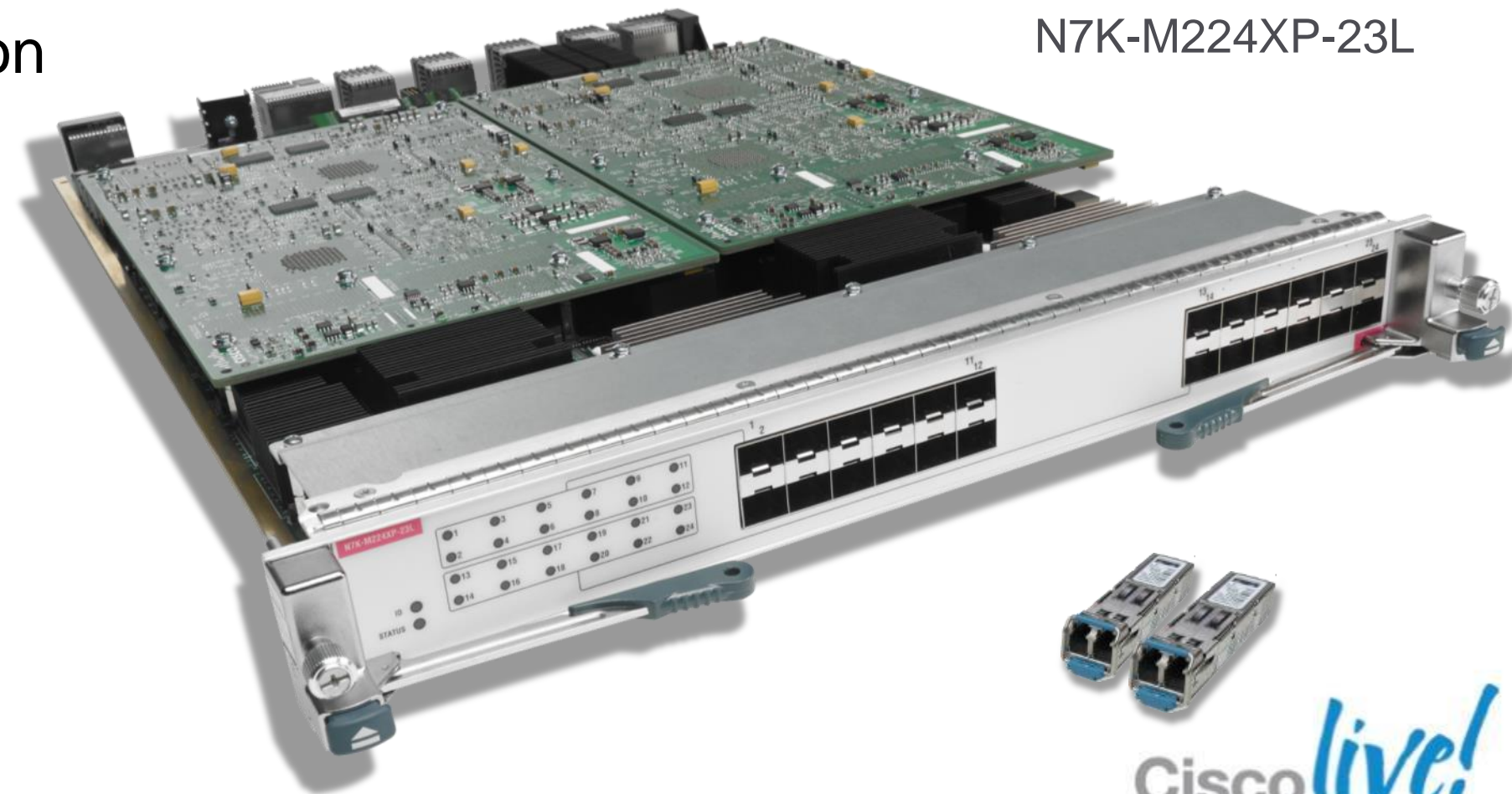

24-Port 10G M2 I/O Module Architecture

N7K-M224XP-23L

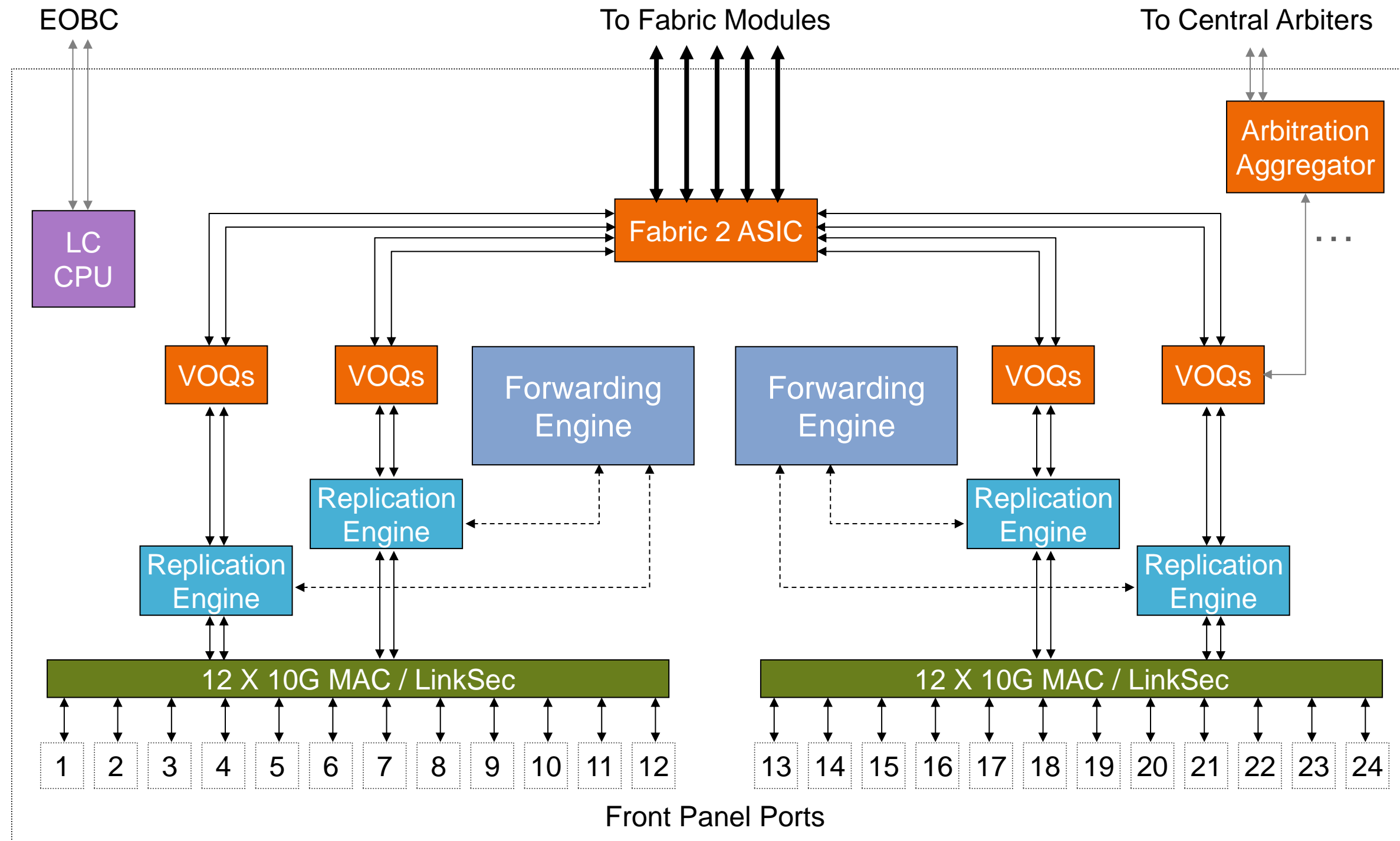

6-Port 40G M2 I/O Module

N7K-M206FQ-23L

- 6-port 40G with QSFP+ transceivers
 - Option to breakout to 4X10G interfaces per 40G port*
- 240G full-duplex fabric connectivity
- Two integrated forwarding engines (120Mpps)
- Support for “XL” forwarding tables (licensed feature)
- Distributed L3 multicast replication
- 802.1AE LinkSec on all ports

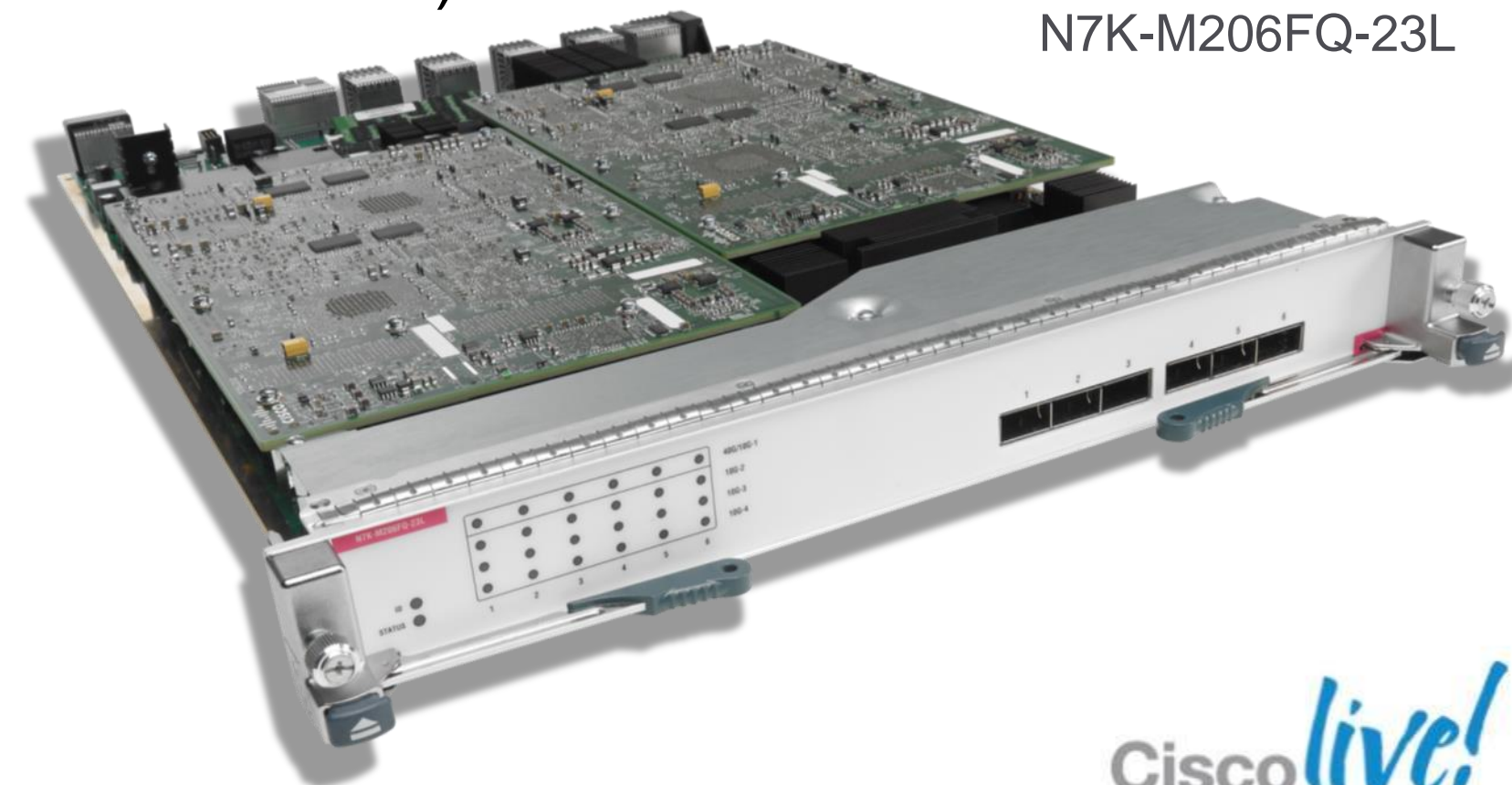

N7K-M206FQ-23L

* Roadmap feature

6-Port 40G M2 I/O Module Architecture

N7K-M206FQ-23L

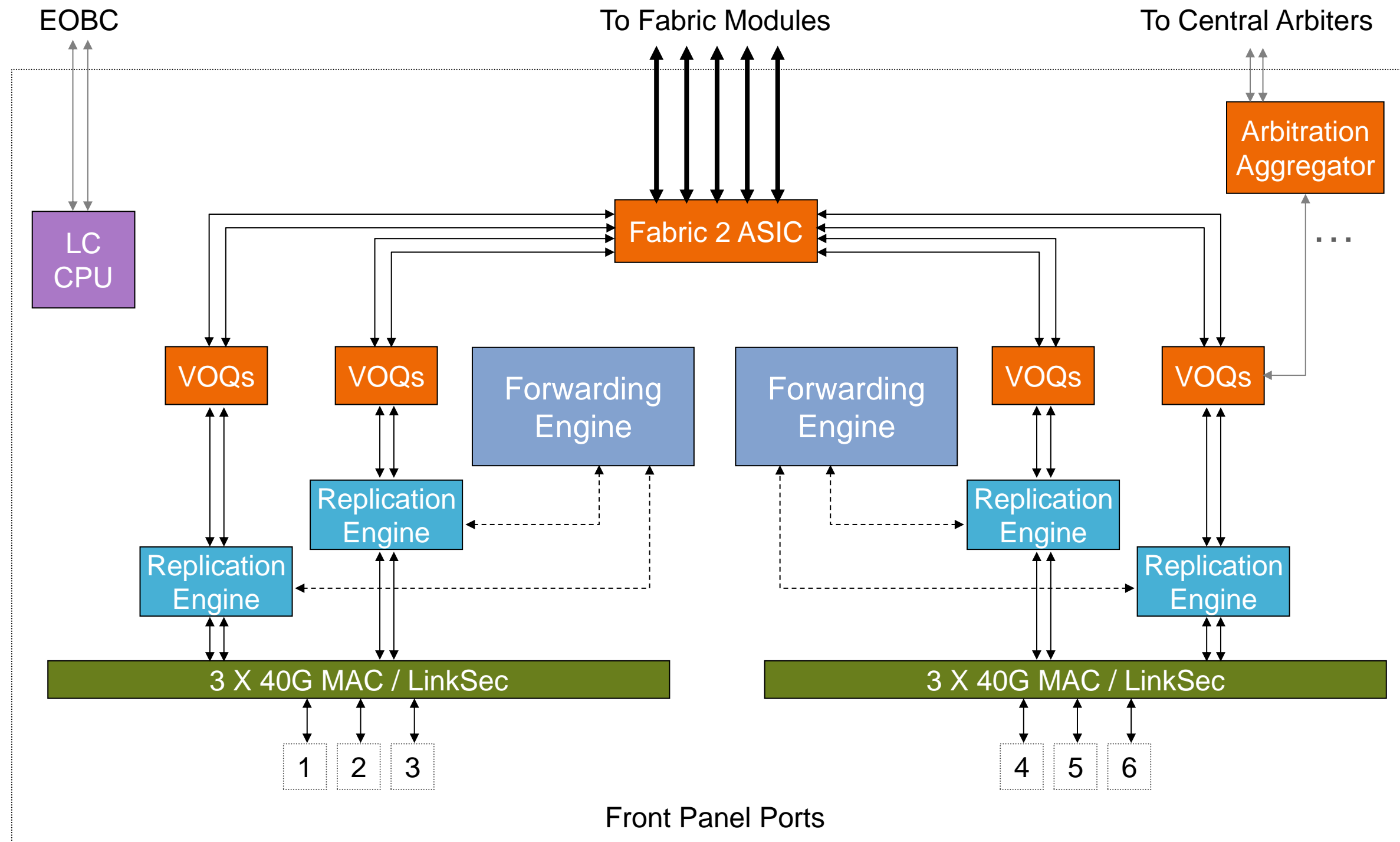

40G Transceivers – QSFP+

- 40GBASE-SR4 supported in 6.1(1)
 - 12-fibre MPO/MTP connector
 - 100m over OM3 MMF, 150m over OM4 MMF
- Other form-factors TBA



QSFP-40G-SR4

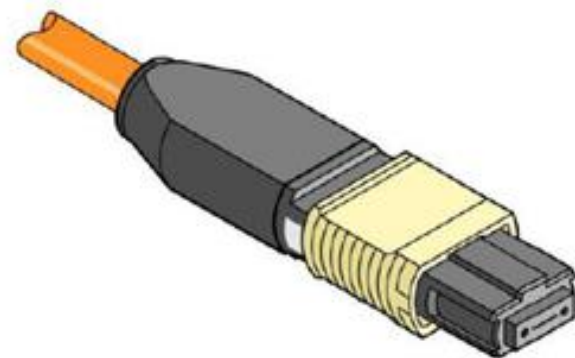

MPO Optical Connector



Interior of ribbon fibre cable

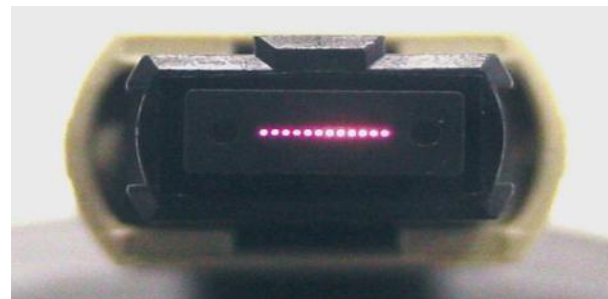

40G MPO interface
(one row of 12 fibres)

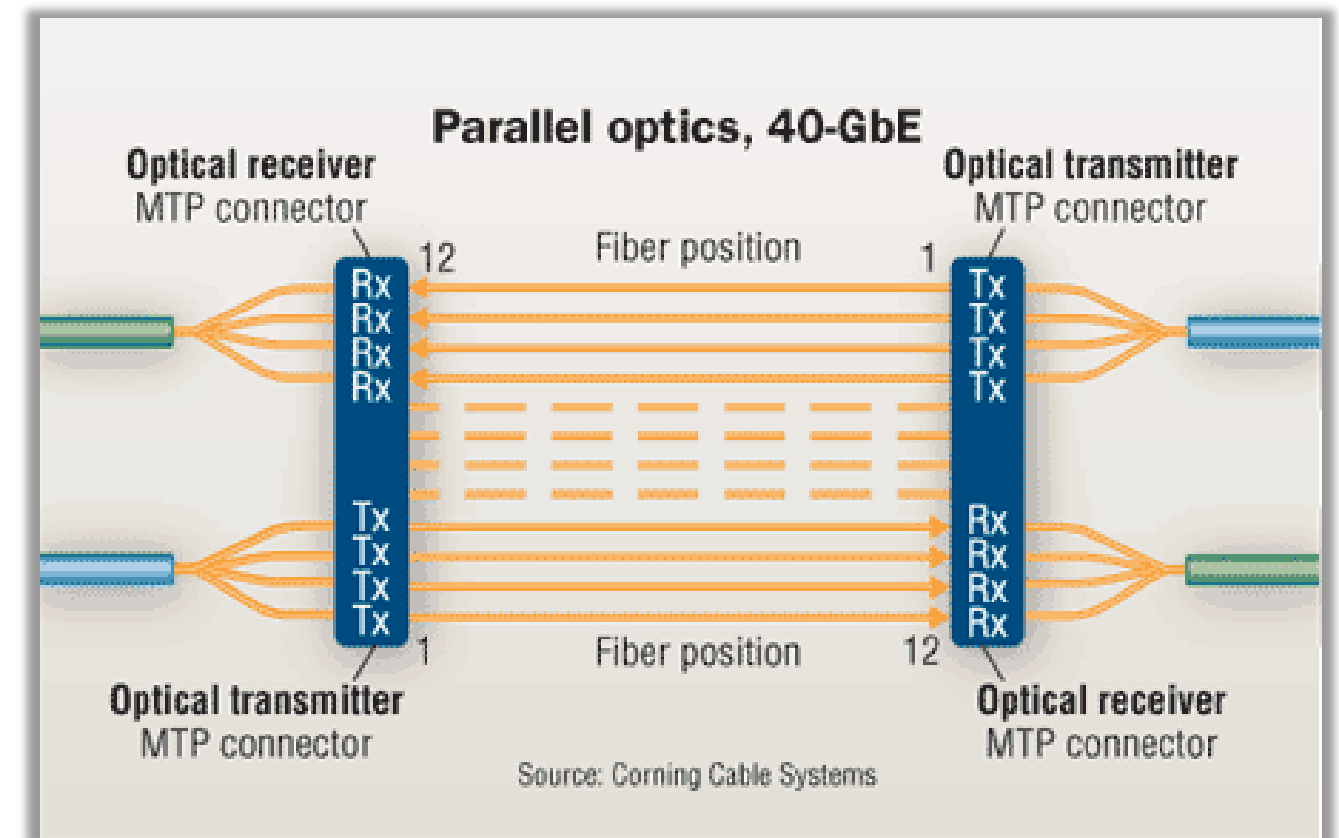

40G 12-strand ribbon fibre
(4 middle fibres unused)

2-Port 100G M2 I/O Module

N7K-M202CF-22L

- 2-port 100G with CFP transceivers
 - Option to breakout to 2X40G or 10X10G interfaces per 100G port*
- 200G full-duplex fabric connectivity
- Two integrated forwarding engines (120Mpps)
- Support for “XL” forwarding tables (licensed feature)
- Distributed L3 multicast replication
- 802.1AE LinkSec on all ports

N7K-M202CF-22L

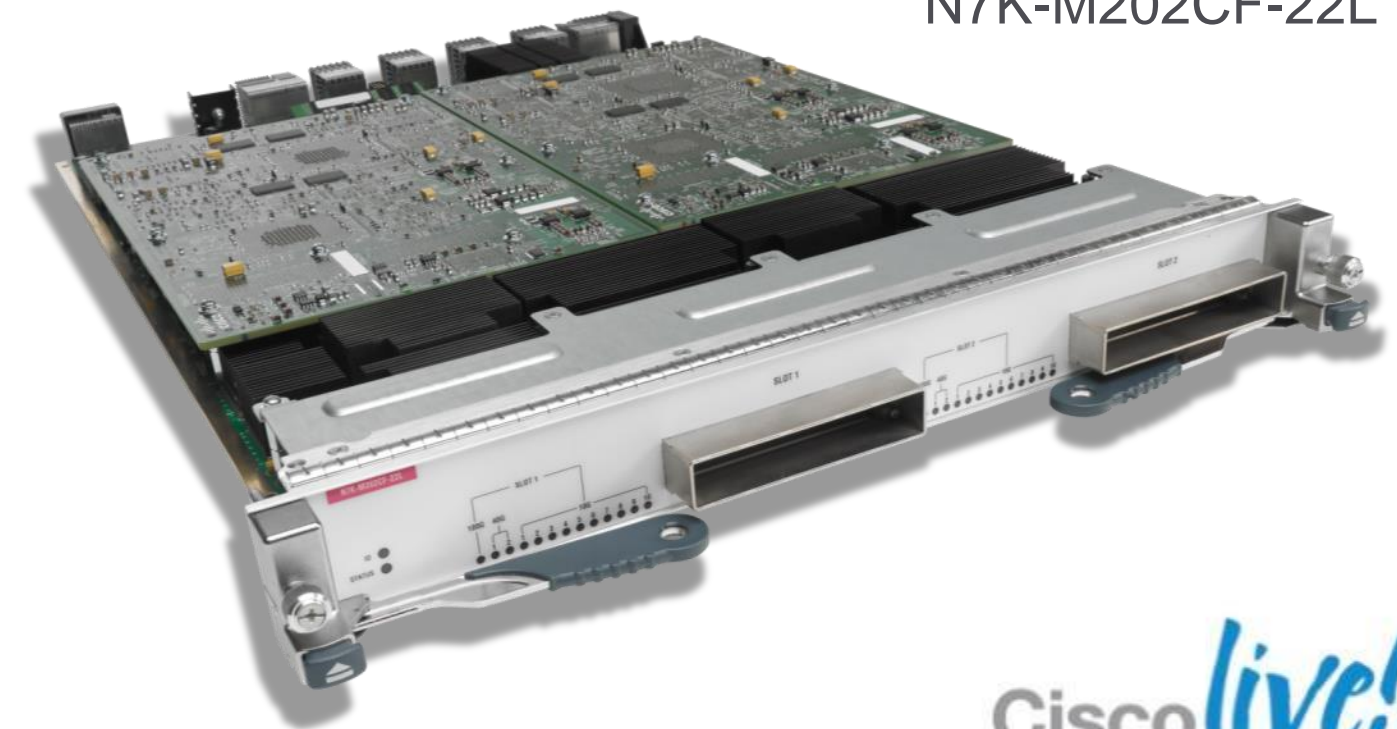

* Roadmap feature

2-Port 100G M2 I/O Module Architecture

N7K-M202CF-22L

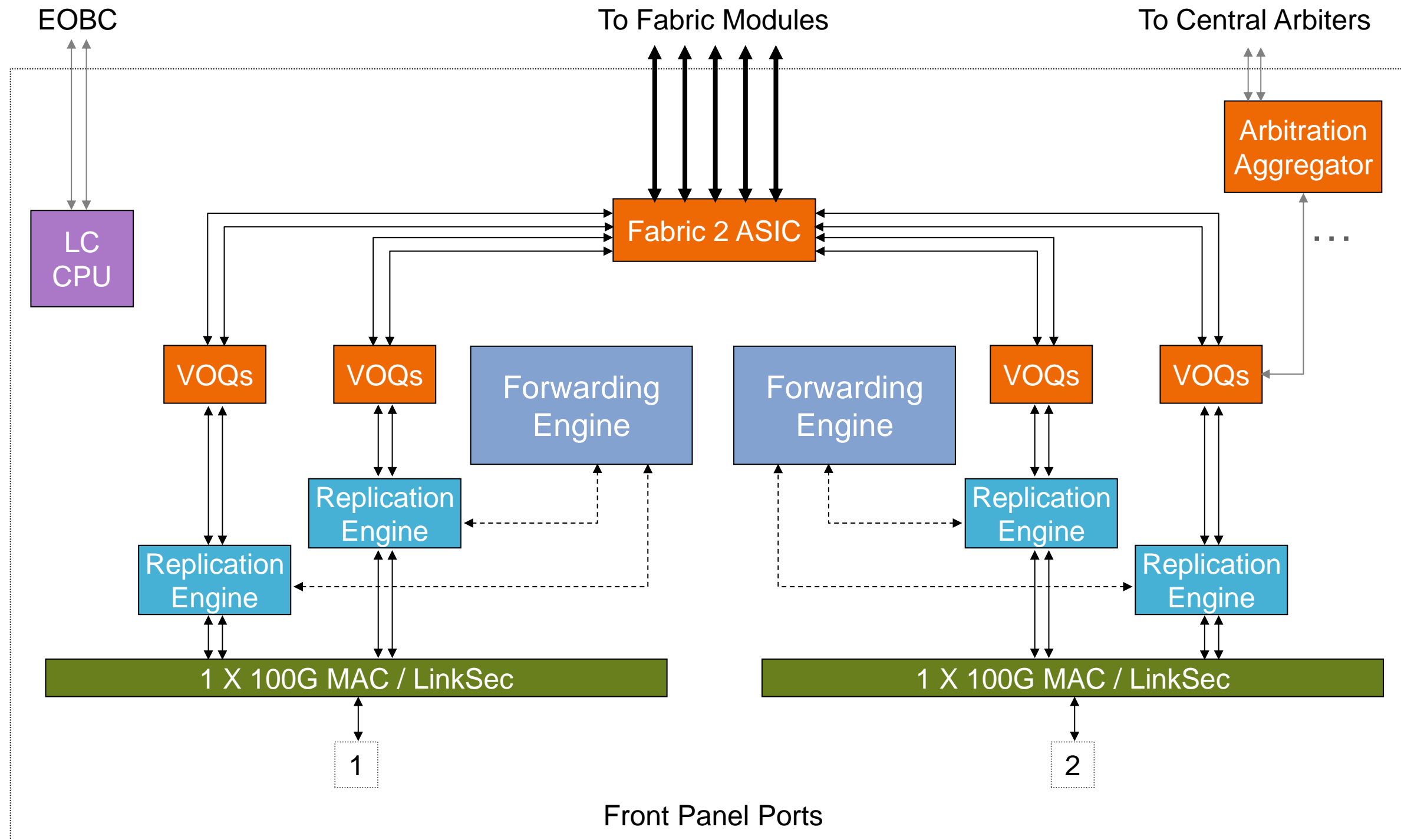

100G Module Transceivers – 40G and 100G CFP

- 100GBASE-LR4 supported from 6.1(1)
 - SC connector
 - 10km over SMF
- Other form-factors on roadmap

- 40GBASE-SR4 supported from 6.1(2)
 - 12-fibre MPO/MTP connector
 - 100m over MMF
- 40GBASE-LR4 supported from 6.1(2)
 - SC connector
 - 10km over SMF

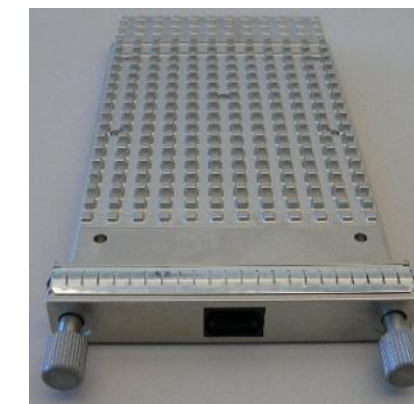

CFP-40G-SR4

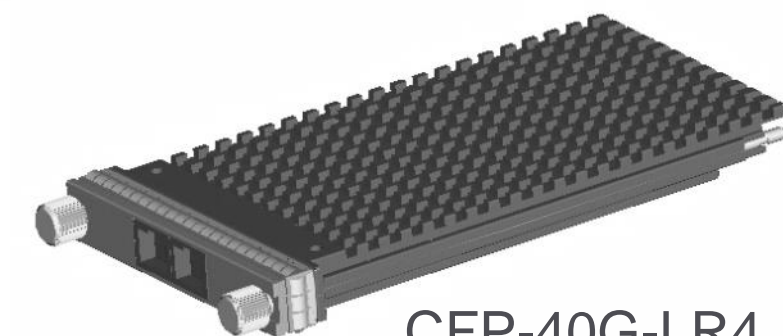

CFP-40G-LR4

40G and 100G Flow Limits – Internal versus “On the Wire”

Internal to Nexus 7000 System

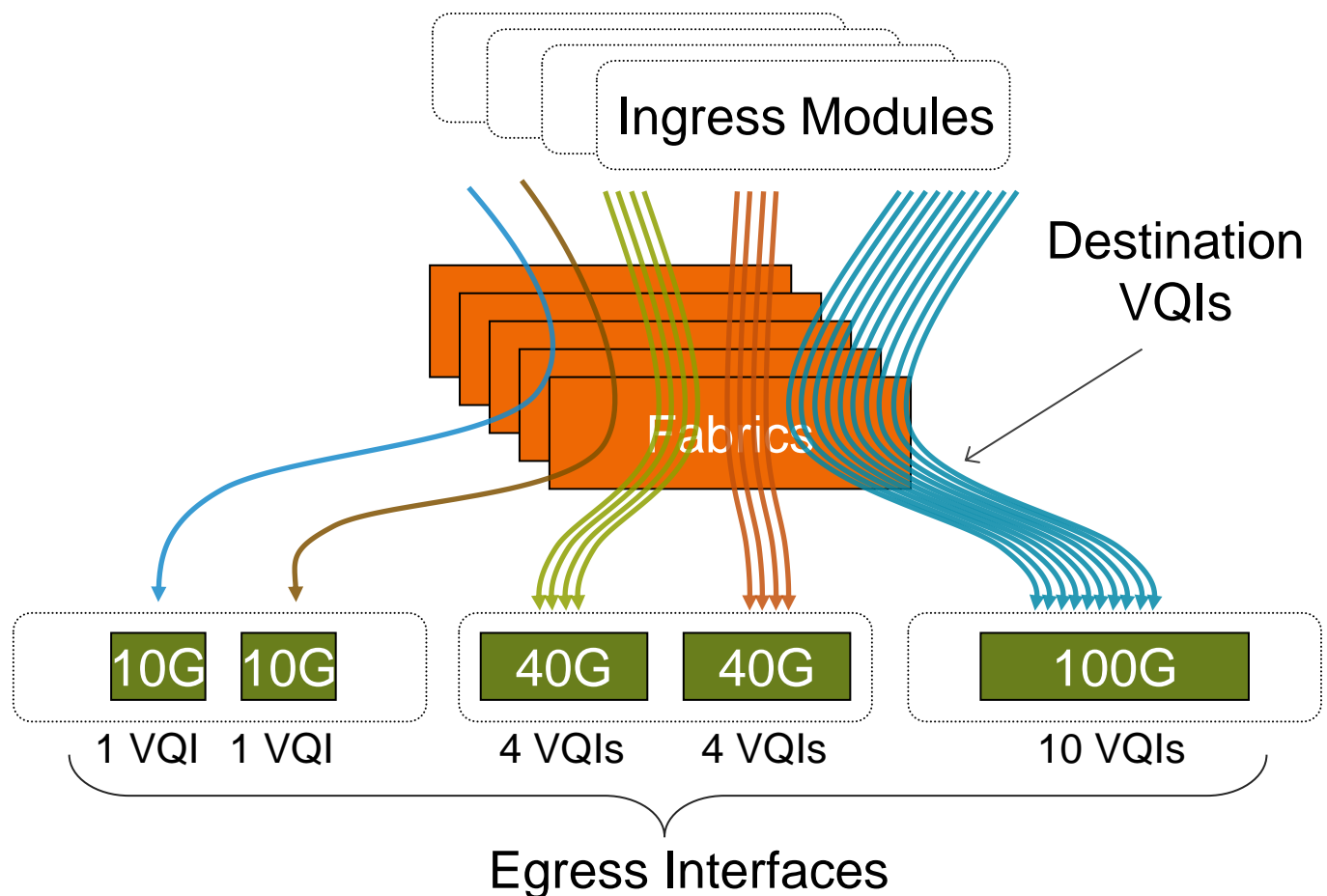

- Each VQI sustains 10-12G traffic flow
- Single-flow limit is ~10G

On the Wire (40G)

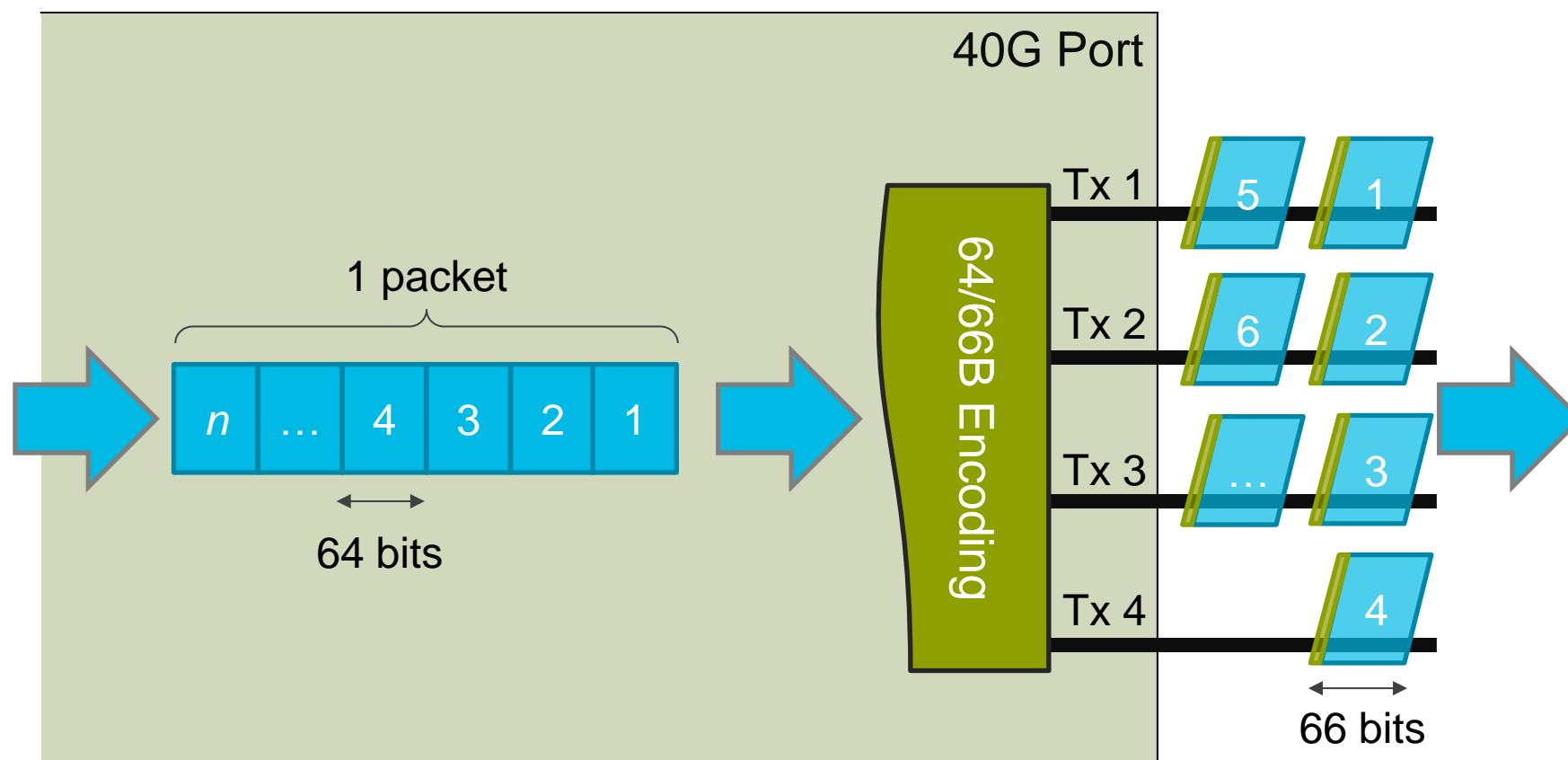

- Packets split into 66-bit “code words”
- Four code words transmitted in parallel, one on each physical Tx fibre
- No per-flow limit imposed – splitting occurs at physical layer

48-Port 1G/10G F2 I/O Module

N7K-F248XP-25

- 48-port 1G/10G with SFP/SFP+ transceivers
- 480G full-duplex fabric connectivity
- System-on-chip (SoC)* forwarding engine design
 - 12 independent SoC ASICs
- Layer 2/Layer 3 forwarding with L3/L4 services (ACL/QoS)
- Supports Nexus 2000 (FEX) connections
- FabricPath-capable
- FCoE-capable

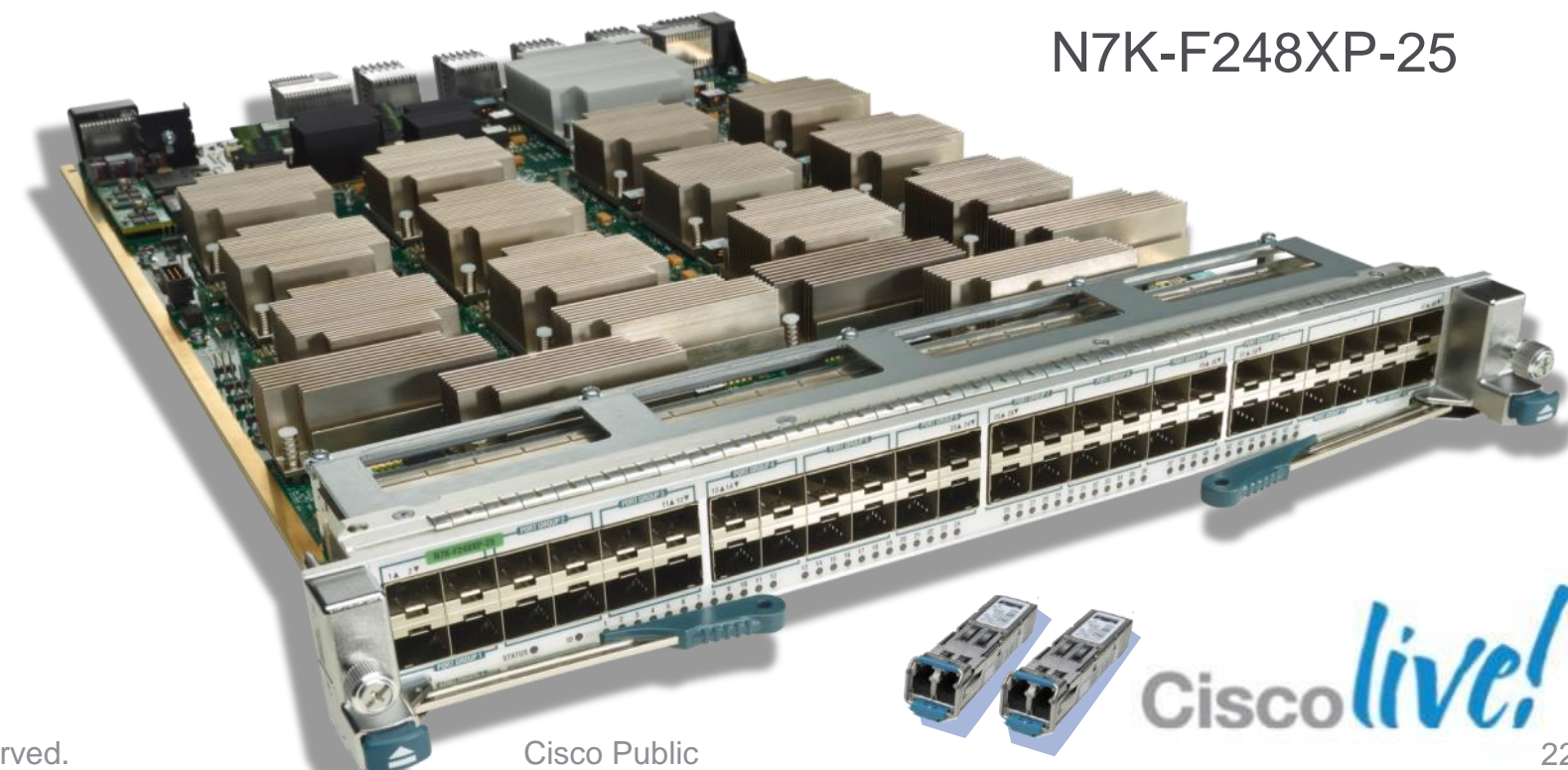

* sometimes called “switch-on-chip”

48-Port 1G/10G F2E I/O Modules (Fibre and Copper)

N7K-F248XP-25E / N7K-F248XT-25E

- Enhanced version of original F2 I/O module
- Fibre and copper version
- 480G full-duplex fabric connectivity
- Same basic SoC architecture as original F2 with some additional functionality

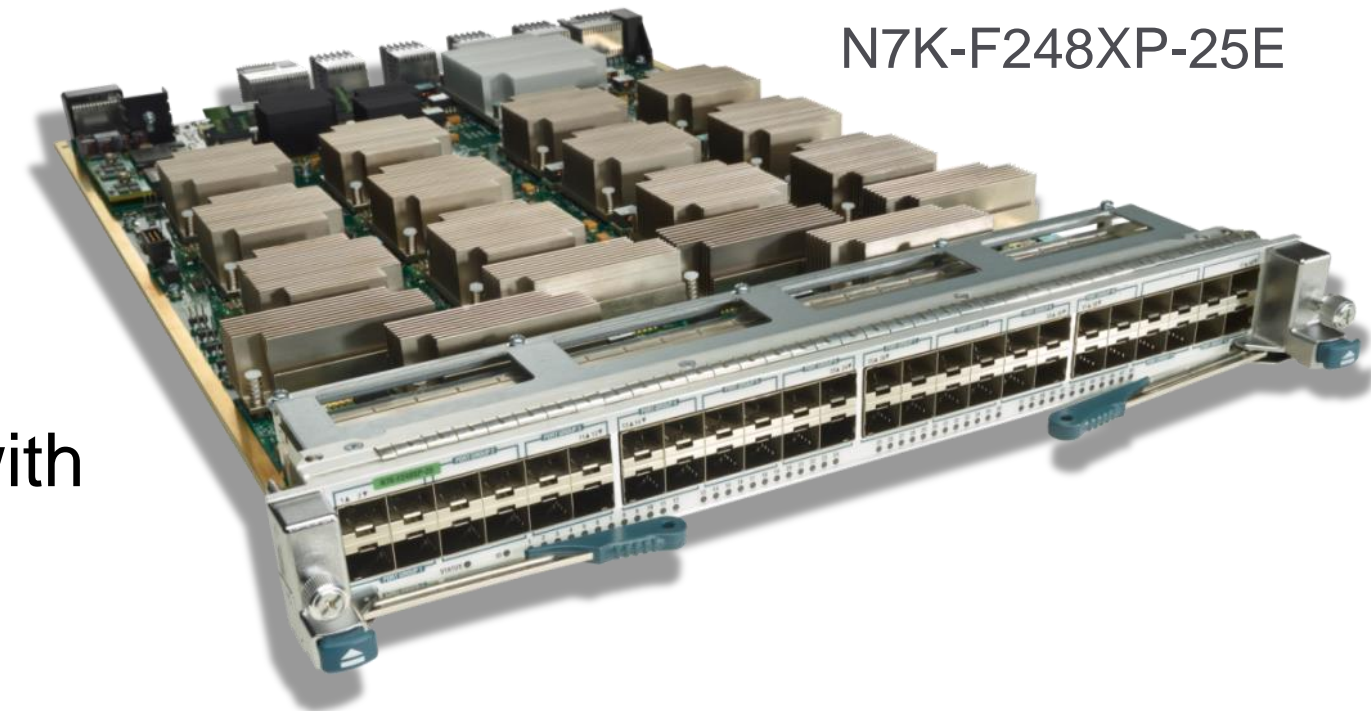

N7K-F248XP-25E

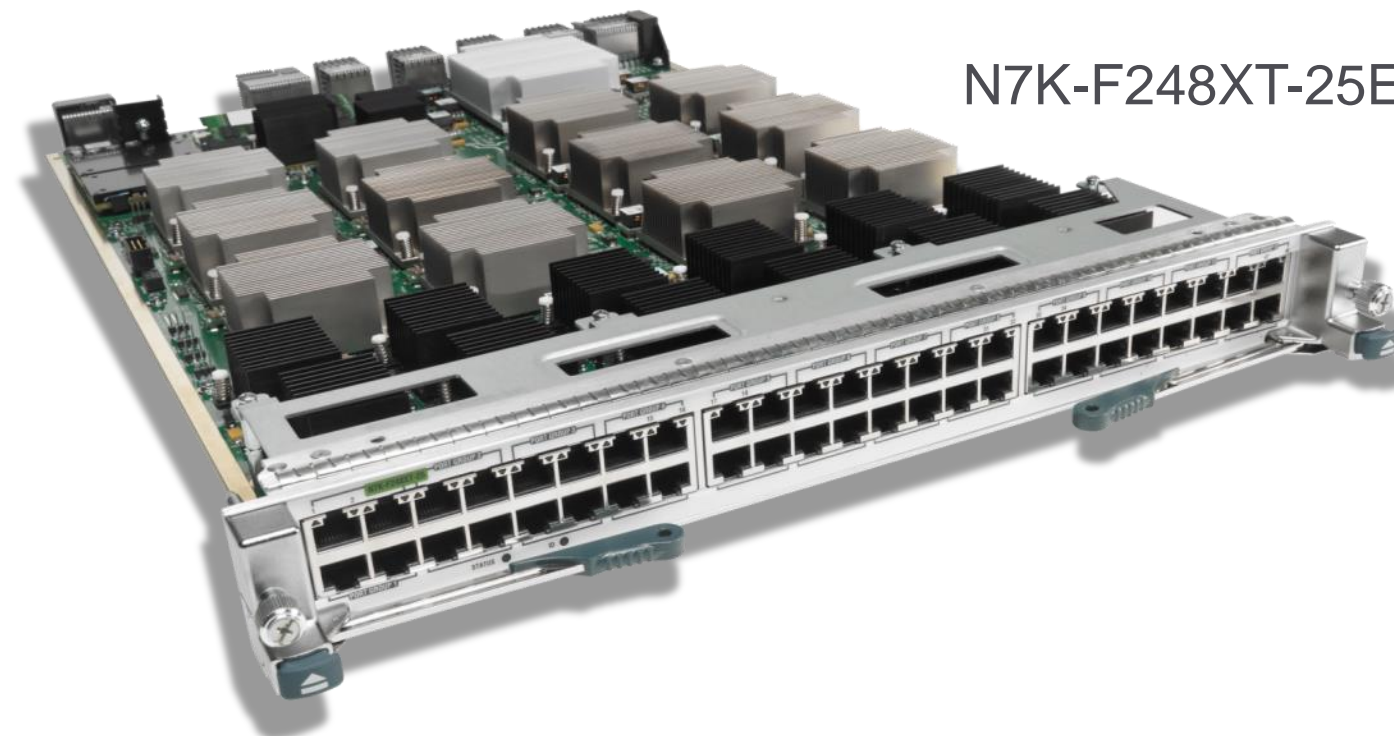

N7K-F248XT-25E

What's Different in F2E?

- Interoperability with M1/M2, in Layer 2 mode*
 - Proxy routing for inter-VLAN/L3 traffic
- LinkSec support*
 - Fibre version: 8 ports
 - Copper version: 48 ports
- Energy Efficient Ethernet (EEE) capability on F2E copper version

* Roadmap feature

48-Port 1G/10G F2 / F2E I/O Module Architecture

N7K-F248XP-25 / N7K-F248XP-25E / N7K-F248XT-25

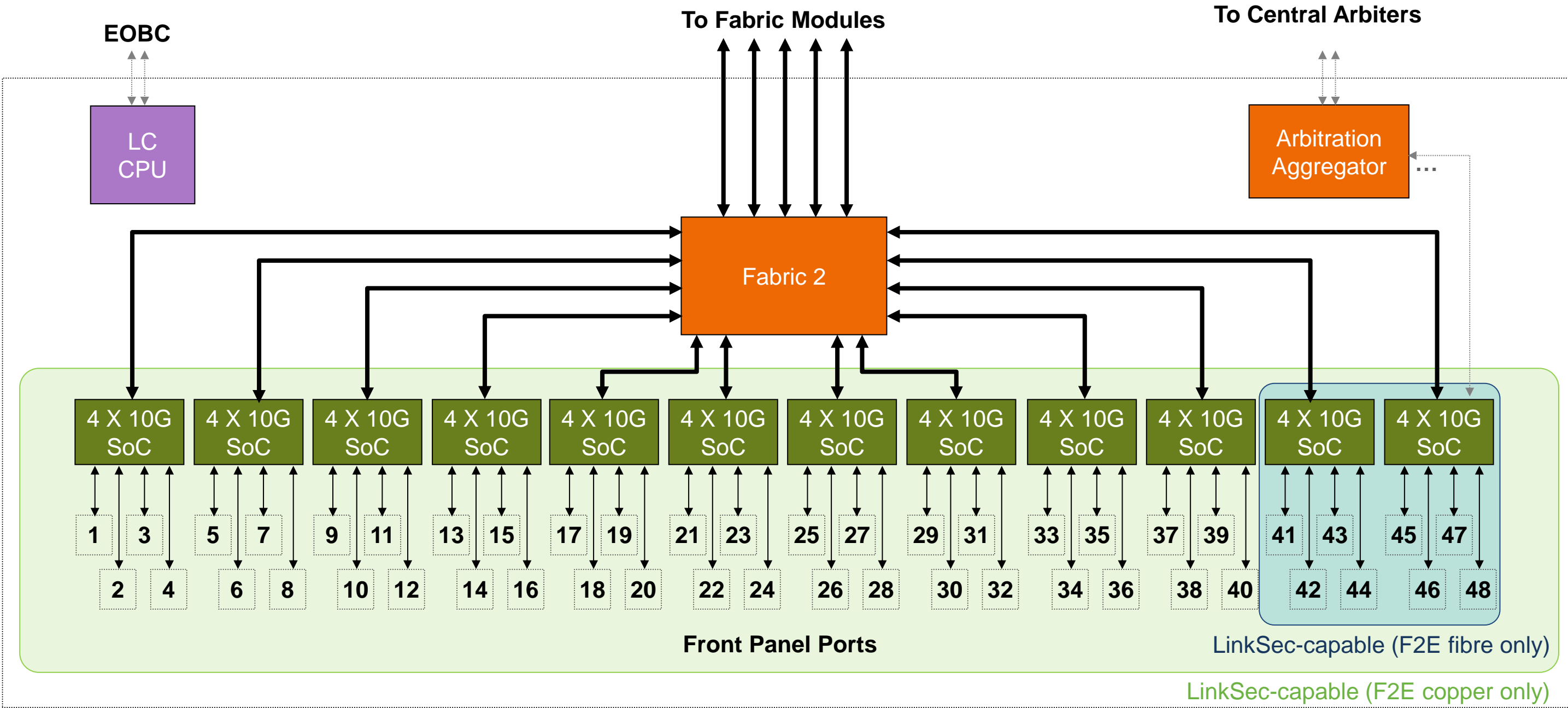

F2-Only VDC

- F2/F2E modules do **not** interoperate with other Nexus 7000 modules*
- Must deploy in an “F2 only” VDC
- Can be default VDC, or any other VDC
 - Use the **limit-resource module-type f2** VDC configuration command
- System with only F2 modules and empty configuration boots with F2-only default VDC automatically

Communication between F2-only VDC and M1/M2/F1 VDC must be through external connection

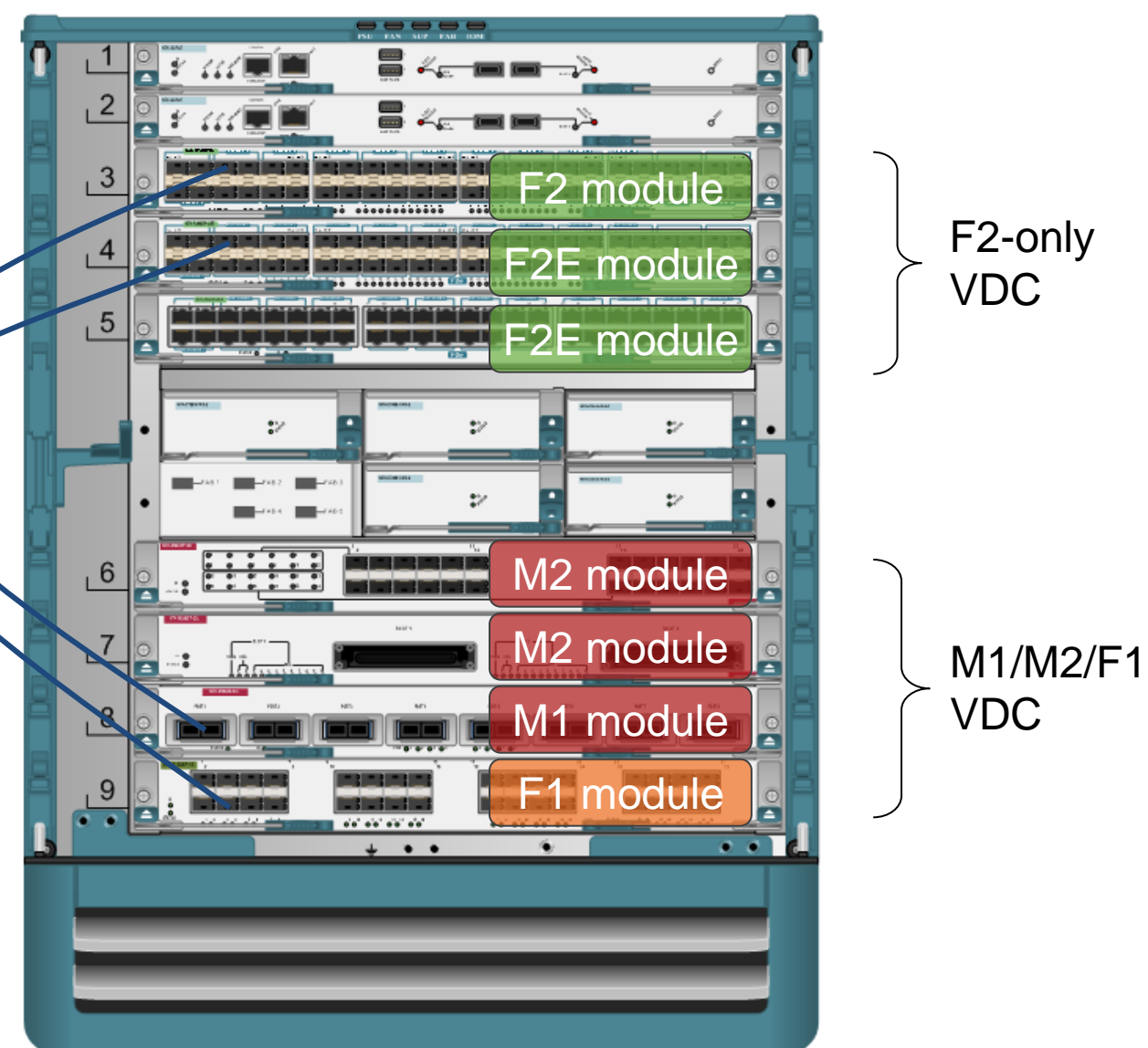

M1/M2/F1 modules can exist in same **chassis** as F2/F2E modules, but **not** in the same VDC

* F2E will interoperate in Layer 2 mode with M1/M2 in a future software release

Agenda

- Chassis Architecture
- Supervisor Engine and I/O Module Architecture
- **Forwarding Engine Architecture**
- Fabric Architecture
- I/O Module Queuing
- Layer 2 Forwarding
- IP Forwarding
- Classification
- NetFlow
- Conclusion

M-Series Forwarding Engine Hardware

- Hardware forwarding engine(s) integrated on every I/O module
- 60Mpps per forwarding engine Layer 2 bridging with hardware MAC learning
- 60Mpps per forwarding engine Layer 3 IPv4 and 30Mpps Layer 3 IPv6 unicast
- Layer 3 IPv4 and IPv6 multicast support (SM, SSM, bidir)
- MPLS
- OTV
- IGMP snooping
- RACL/VACL/PACL
- QoS remarking and policing policies
- Policy-based routing (PBR)
- Unicast RPF check and IP source guard
- Ingress and egress NetFlow (full and sampled)

Hardware Table	M-Series Modules without Scale License	M-Series Modules with Scale License
FIB TCAM	128K	900K
Classification TCAM (ACL/QoS)	64K	128K
MAC Address Table	128K	128K
NetFlow Table	512K	512K

M-Series Forwarding Engine Architecture

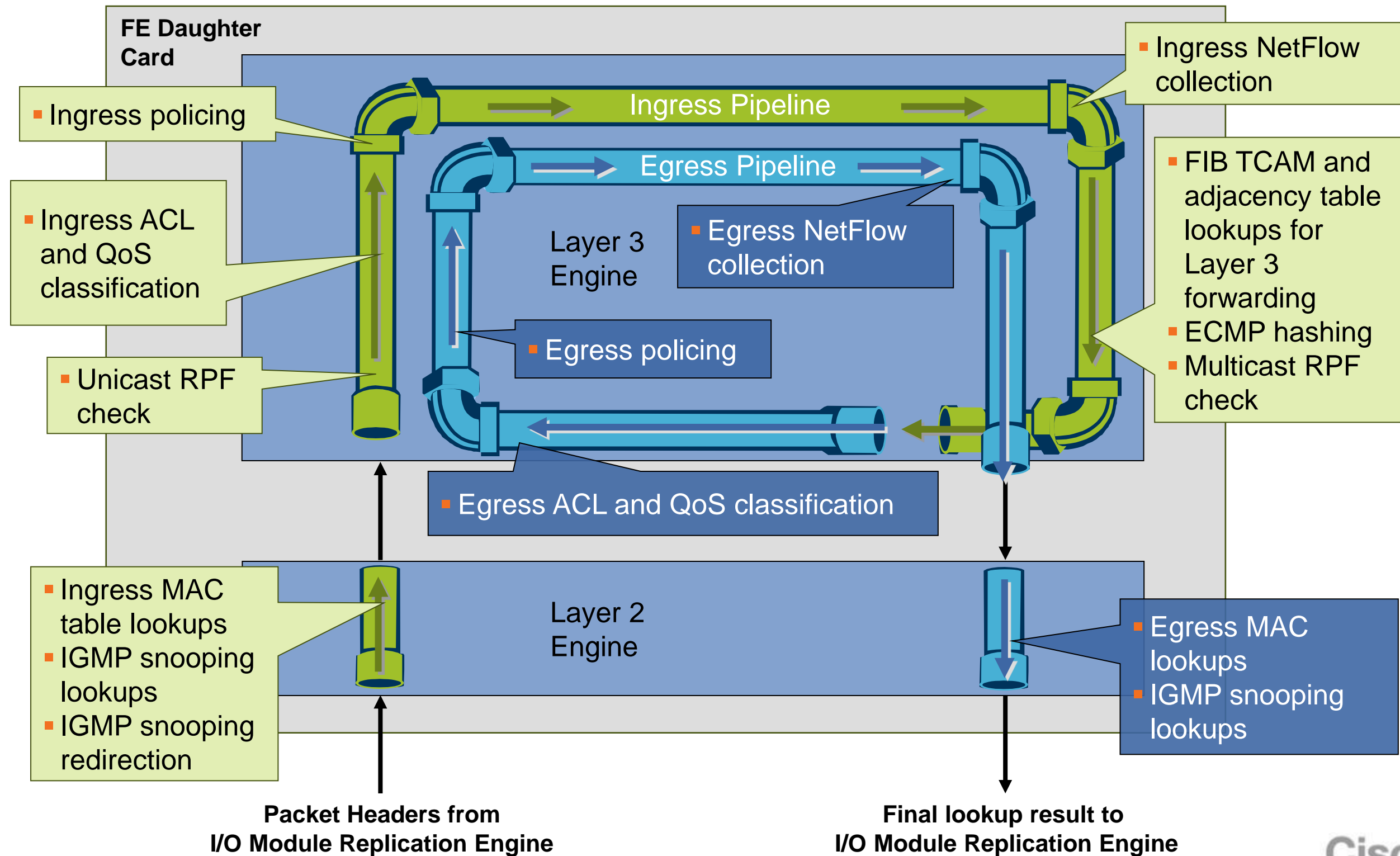

F2/F2E Forwarding Engine Hardware

- Each SoC forwarding engine services 4 front-panel 10G ports (12 SoCs per module)
- 60Mpps per SoC Layer 2 bridging with hardware MAC learning
- 60Mpps per forwarding engine Layer 3 IPv4/IPv6 unicast
- Layer 3 IPv4 and IPv6 multicast support (SM, SSM)
- IGMP snooping
- RACL/VACL/PACL
- QoS remarking and policing policies
- Policy-based routing (PBR)
- Unicast RPF check and IP source guard
- FabricPath forwarding
- Ingress sampled NetFlow
- FCoE

Hardware Table	Per F2 SoC	Per F2 Module
MAC Address Table	16K	256K*
FIB TCAM	32K IPv4/16K IPv6	32K IPv4/16K IPv6
Classification TCAM (ACL/QoS)	16K	192K*

* Assumes specific configuration to scale SoC resources

F2/F2E Forwarding Engine

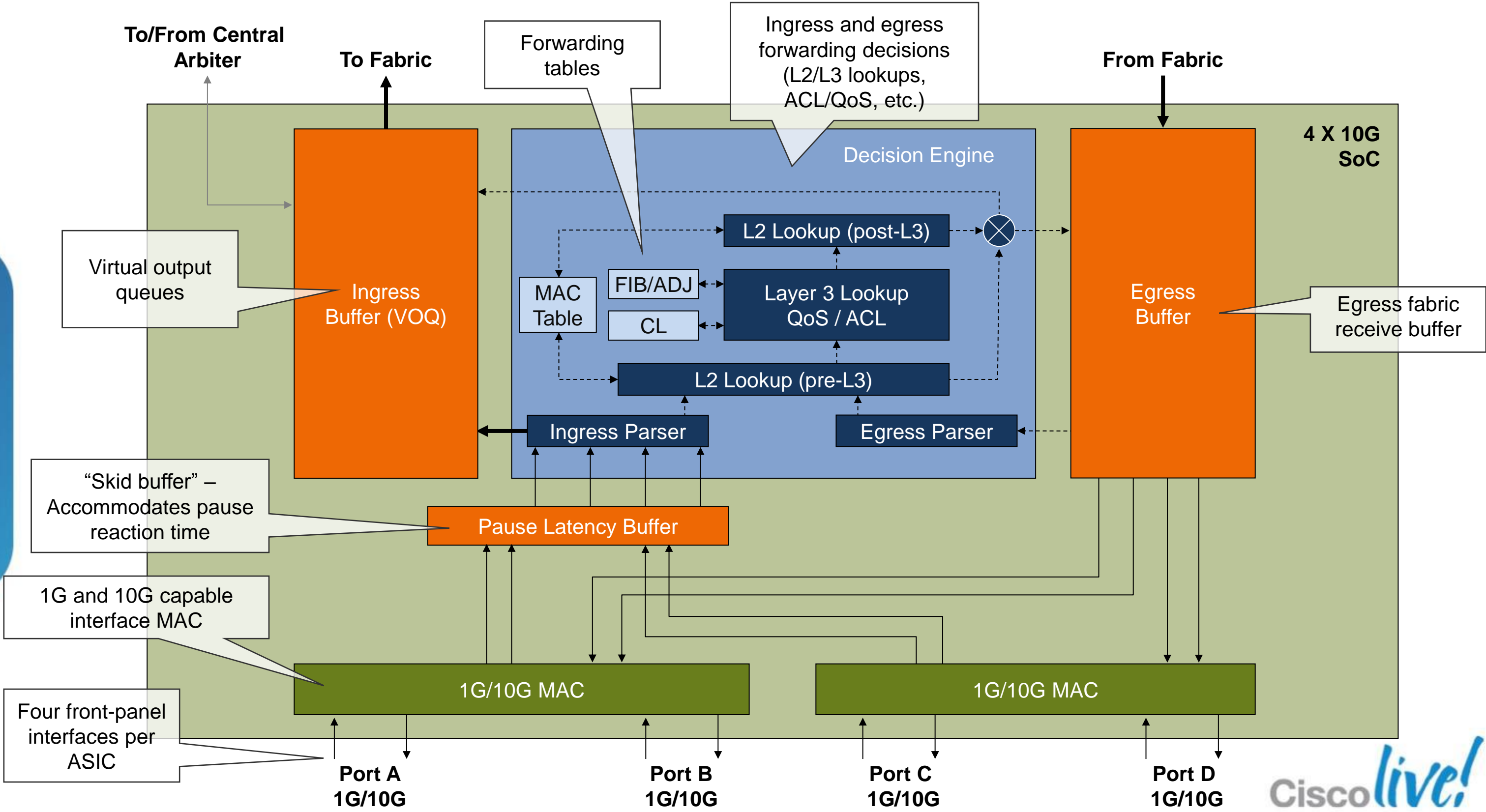

Agenda

- Chassis Architecture
- Supervisor Engine and I/O Module Architecture
- Forwarding Engine Architecture
- **Fabric Architecture**
- I/O Module Queuing
- Layer 2 Forwarding
- IP Forwarding
- Classification
- NetFlow
- Conclusion

Crossbar Switch Fabric Modules

N7K-C7018-FAB-1/FAB-2

- Provide interconnection of I/O modules in Nexus 7009 / 7010 / 7018 chassis
- Each installed fabric increases available per-payload slot bandwidth
- Two fabric generations available – Fabric 1 and Fabric 2

Fabric Module	Supported Chassis	Supported I/O Modules	Per-fabric module bandwidth	Total bandwidth with 5 fabric modules
Fabric 1	7010 / 7018	All	46Gbps per slot	230Gbps per slot
Fabric 2	7009 / 7010 / 7018	All	110Gbps per slot	550Gbps per slot

- Different I/O modules leverage different amount of fabric bandwidth
- Access to fabric bandwidth controlled using QoS-aware central arbitration with VOQ



N7K-C7009-FAB-2

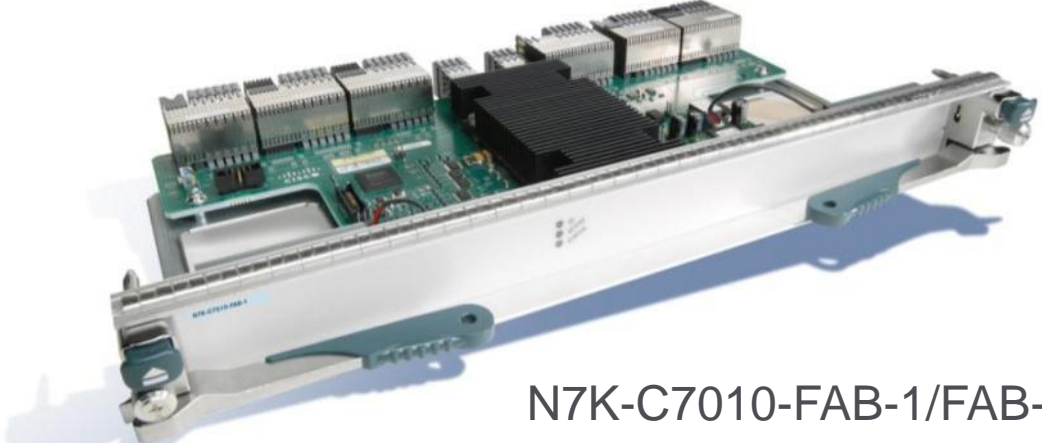

N7K-C7010-FAB-1/FAB-2

Multistage Crossbar

Nexus 7000 implements 3-stage crossbar switch fabric

- Stages 1 and 3 on I/O modules
- Stage 2 on fabric modules

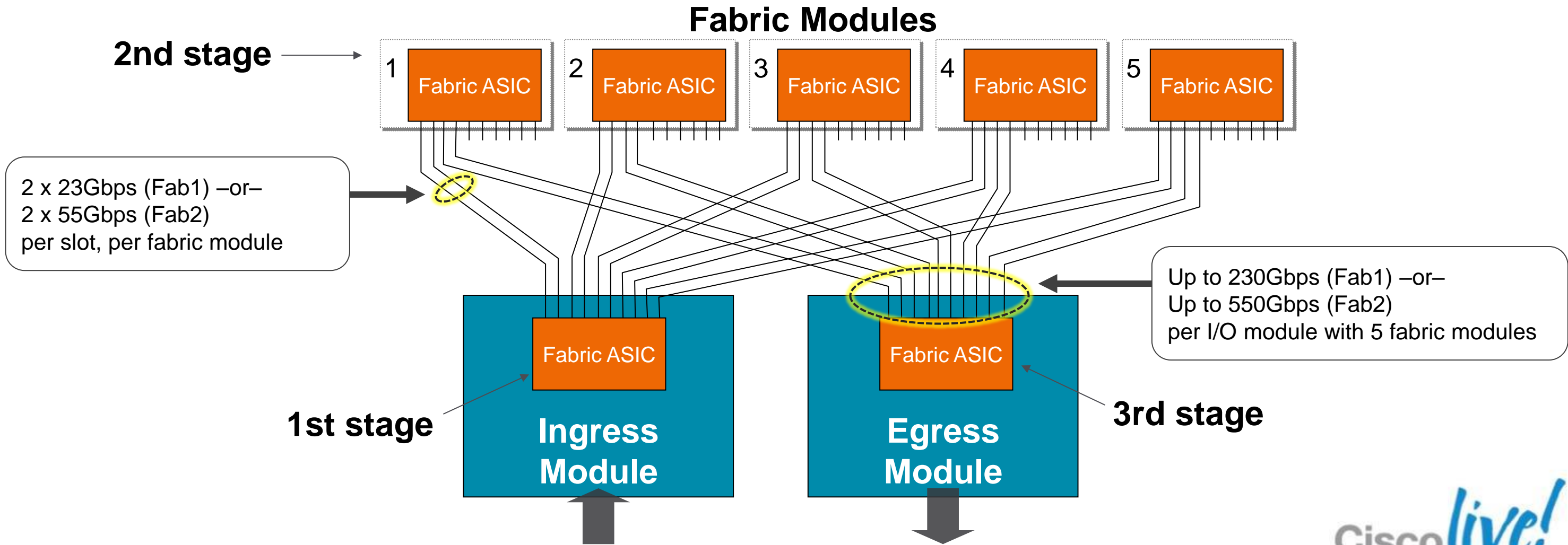

I/O Module Capacity – Fabric 1

230Gbps
per slot bandwidth

One fabric

- **Any port** can pass traffic to **any other port** in system

Two fabrics

- 80G M1 module has full bandwidth

Five fabrics

- 240G M2 module limited to 230G per slot
- 480G F2/F2E module limited to 230G per slot

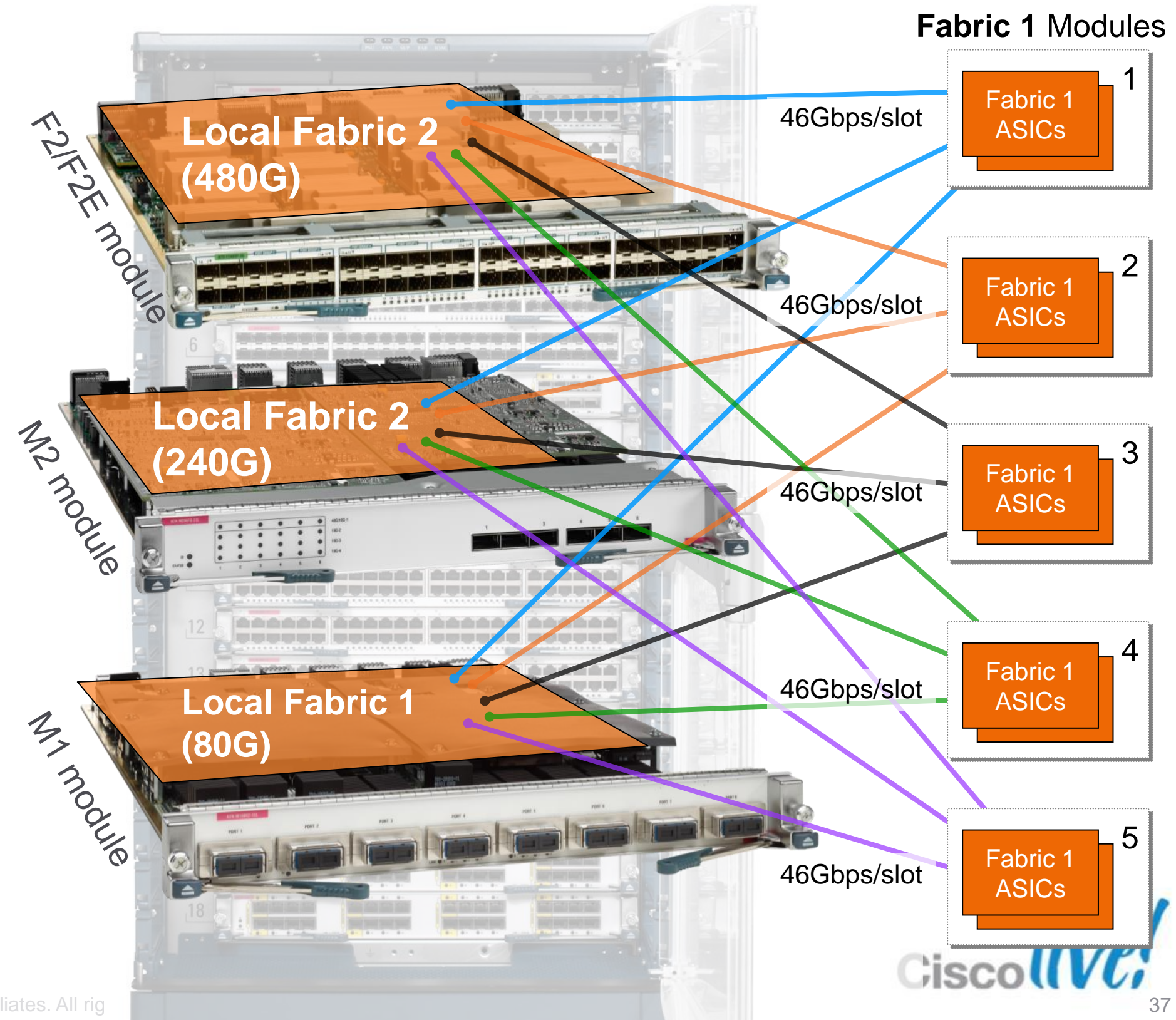

I/O Module Capacity – Fabric 2

Fab2 does NOT make Fab1-based modules faster!!

550Gbps
per slot bandwidth

One fabric

- Any port can pass traffic to any other port in system

Two fabrics

- 80G M1 module has full bandwidth

Three fabrics

- 240G M2 module has maximum bandwidth

Five fabrics

- 480G F2 module has maximum bandwidth

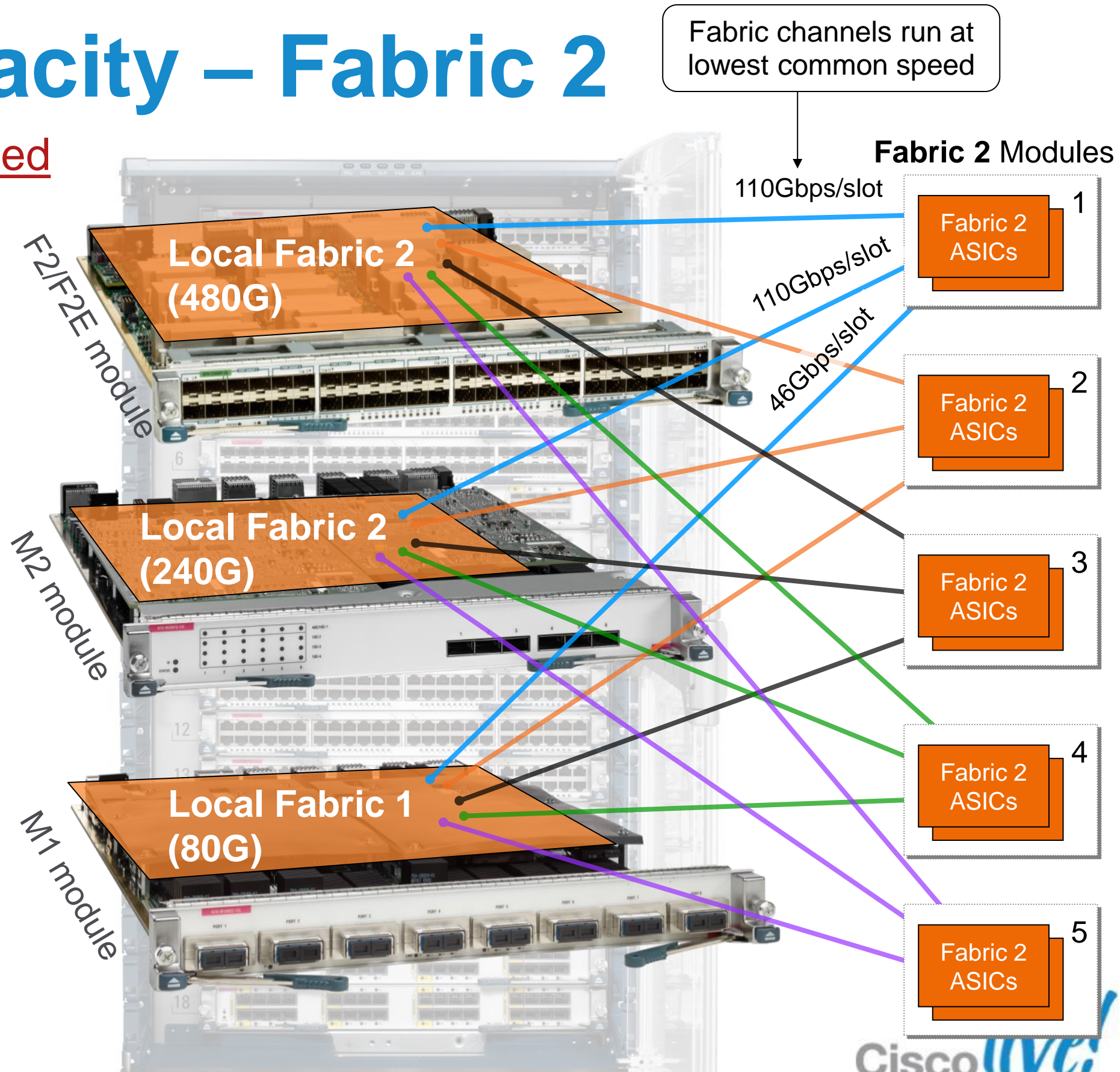

What About Nexus 7004?

- Nexus 7004 has no fabric modules
- I/O modules have local fabric with 10 available fabric channels
 - I/O modules connect “back-to-back” via 8 fabric channels
 - Two fabric channels “borrowed” to connect supervisor engines
- Available inter-module bandwidth dependent on installed module types

M1 Modules in Nexus 7004

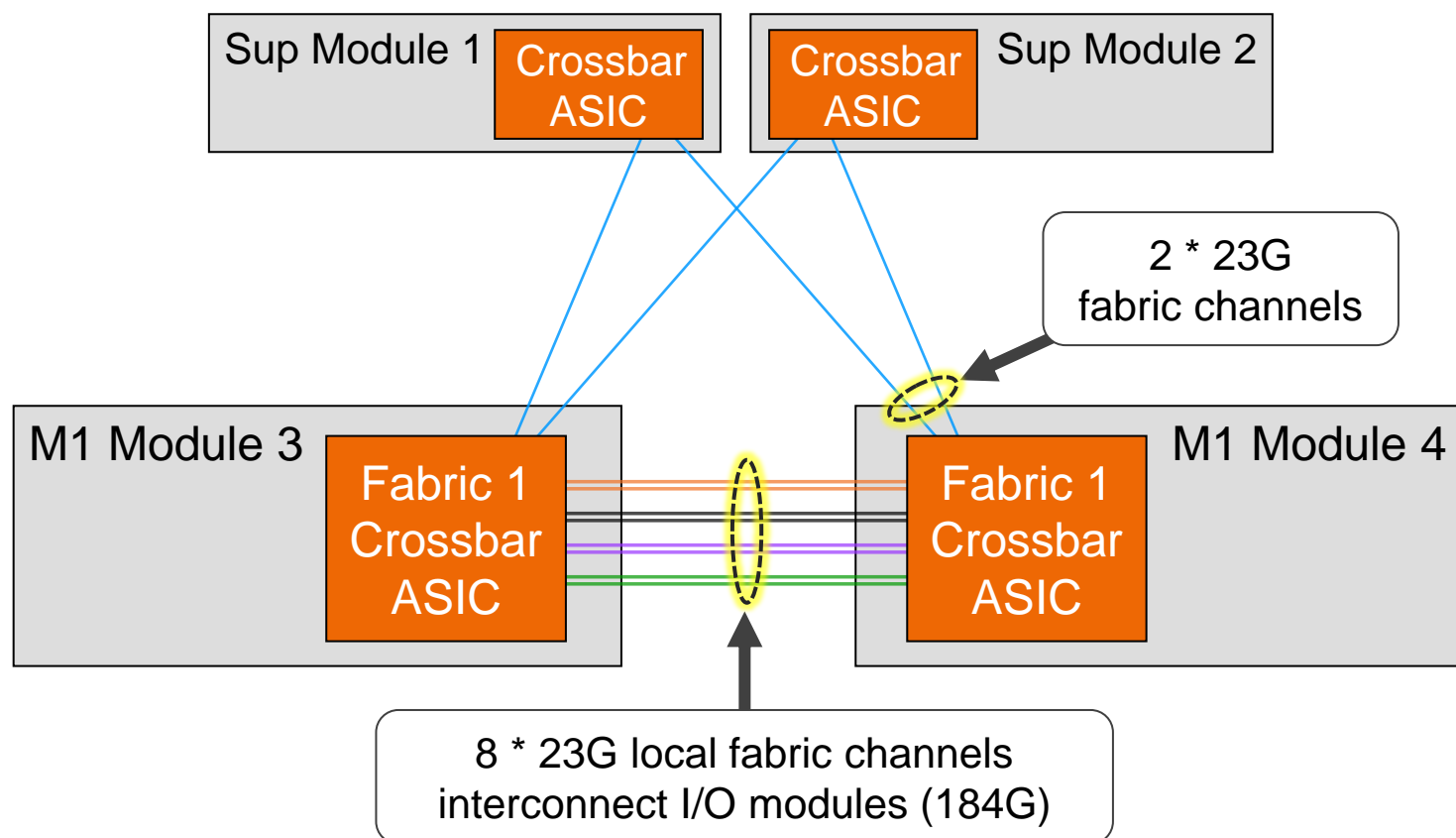

F2/F2E/M2 Modules in Nexus 7004

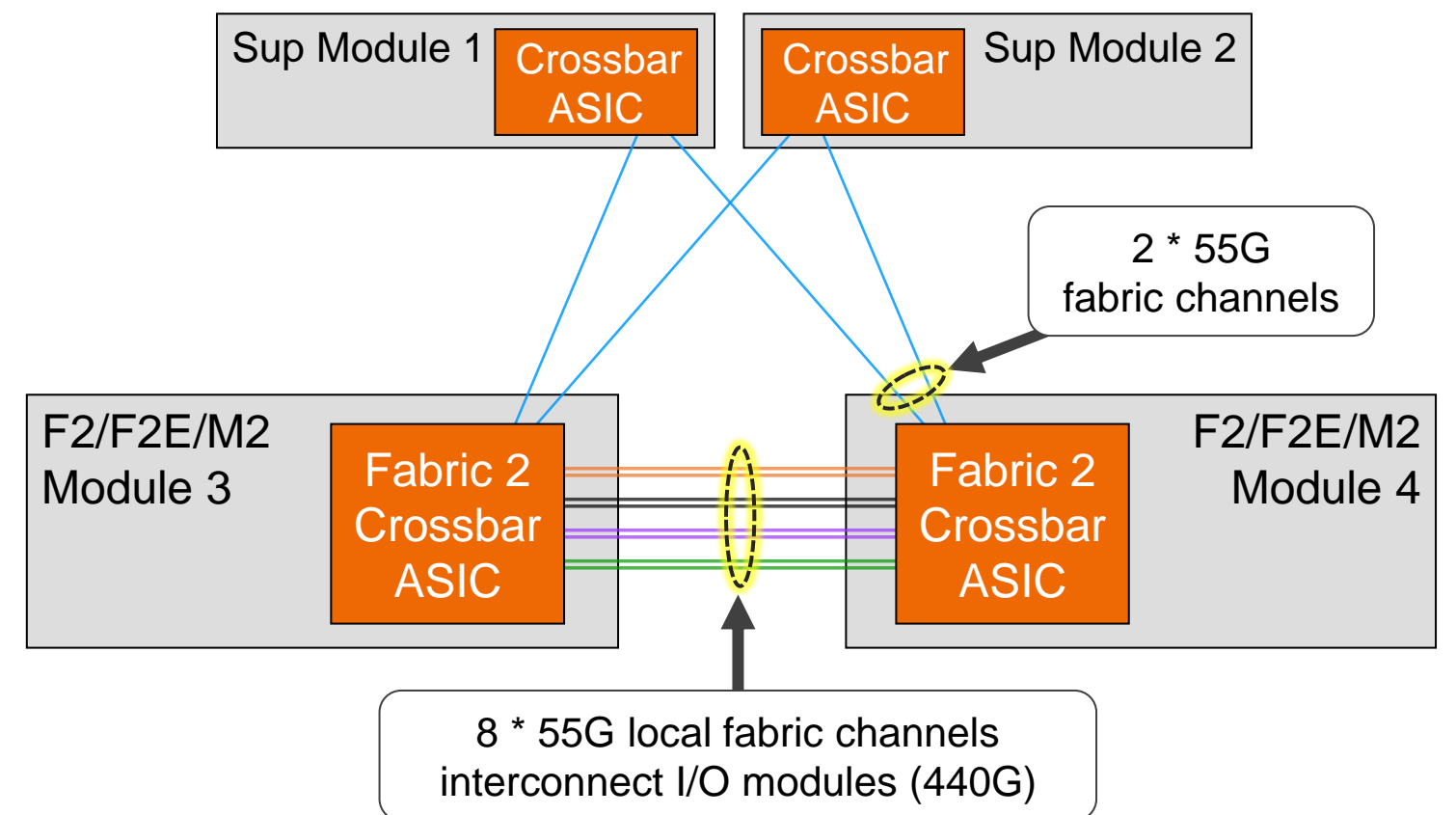

Arbitration, VOQ and Crossbar Fabric

- Arbitration, VOQ, and fabric combine to provide all necessary infrastructure for packet transport inside switch
- **Central arbitration** – Controls **scheduling** of traffic into fabric based on fairness, priority, and bandwidth availability at egress ports
- **Virtual Output Queues (VOQs)** – Provide **buffering** and **queuing** for ingress-buffered switch architecture
- **Crossbar fabric** – Provides dedicated, high-bandwidth interconnects between ingress and egress I/O modules

Agenda

- Chassis Architecture
- Supervisor Engine and I/O Module Architecture
- Forwarding Engine Architecture
- Fabric Architecture
- **I/O Module Queuing**
- Layer 2 Forwarding
- IP Forwarding
- Classification
- NetFlow
- Conclusion

Buffering, Queuing, and Scheduling

- **Buffering** – storing packets in memory
 - Needed to absorb bursts, manage congestion
- **Queuing** – buffering packets according to traffic class
 - Provides dedicated buffer for packets of different priority
- **Scheduling** – controlling the order of transmission of buffered packets
 - Ensures preferential treatment for packets of higher priority and fair treatment for packets of equal priority
- Nexus 7000 uses **queuing policies** and **network-QoS policies** to define buffering, queuing, and scheduling behaviour
- **Default** queuing and network-QoS policies always in effect in absence of any user configuration

I/O Module Buffering Models

- Buffering model varies by I/O module family
 - **M-series modules:** hybrid model combining ingress VOQ-buffered architecture with egress port-buffered architecture
 - **F-series modules:** pure ingress VOQ-buffered architecture
- All configuration through Modular QoS CLI (MQC)
 - Queuing parameters applied using class-maps/policy-maps/service-policies

Hybrid Ingress/Egress Buffered Model

M-Series I/O Modules

- Ingress port buffer – Manages congestion in ingress forwarding/replication engines only
- Ingress VOQ buffer – Manages congestion toward egress destinations (VQIs) over fabric
- Egress VOQ buffer – Receives frames from fabric; also buffers multidestination frames
- Egress port buffer – Manages congestion at egress interface

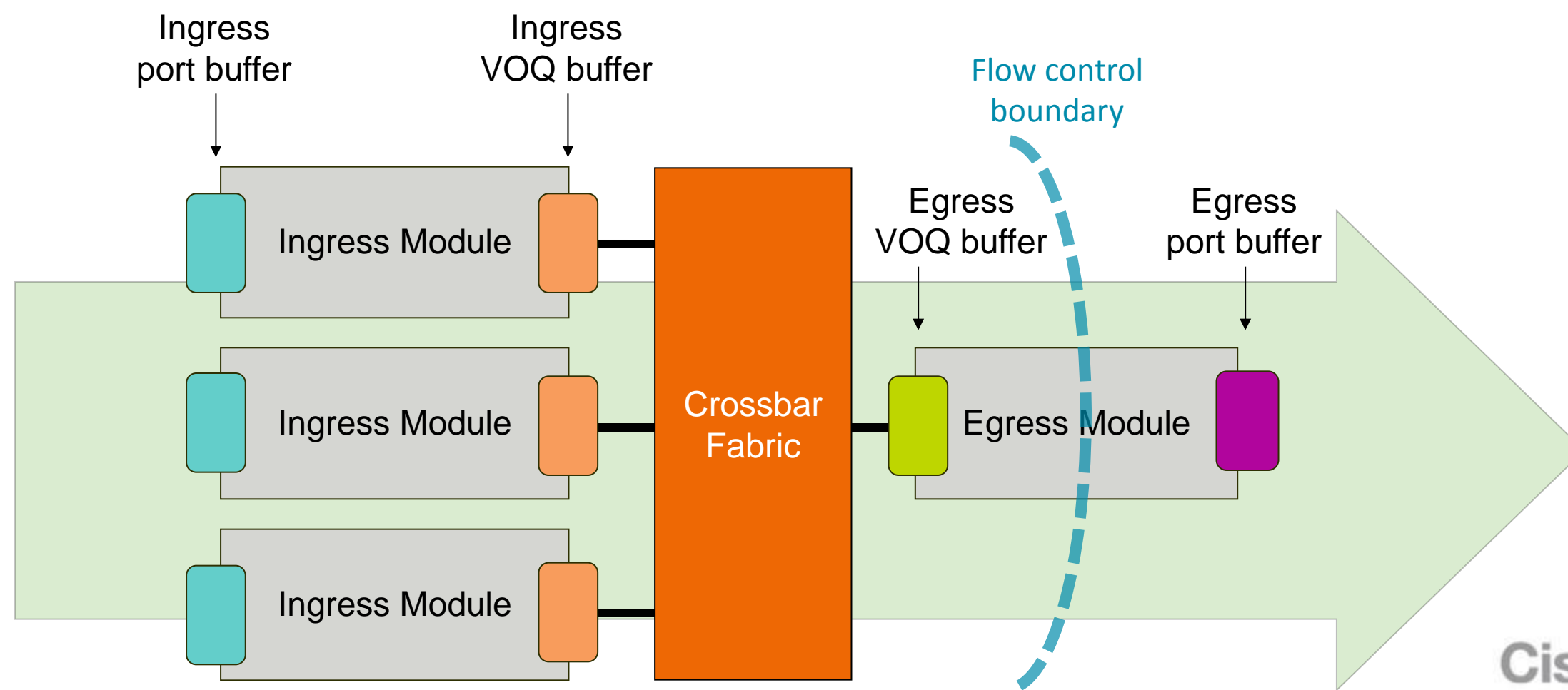

Ingress Buffered Model

F-Series I/O Modules

- Ingress VOQ buffer – Manages congestion toward egress destinations (VQIs) over fabric
- Egress VOQ buffer – Receives frames from fabric; also buffers multidestination frames

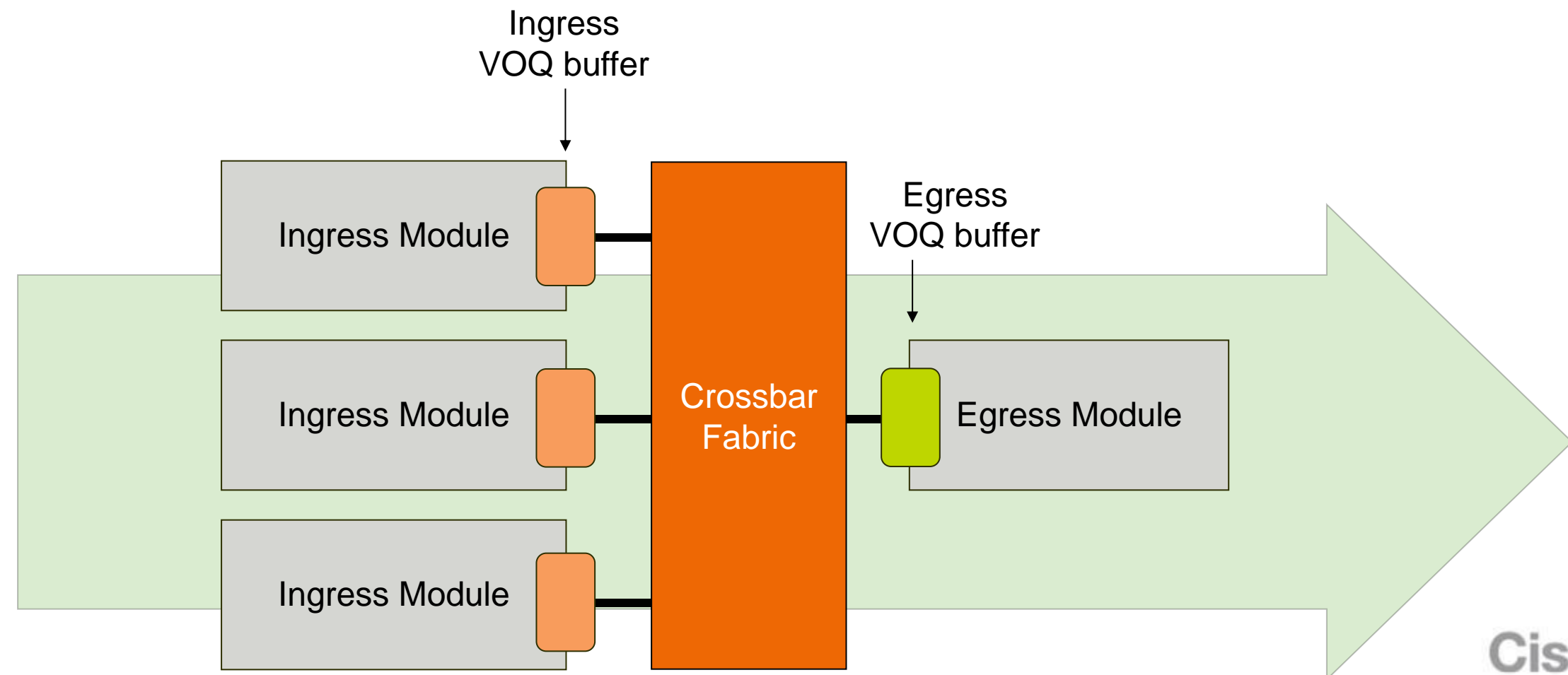

Distributed Buffer Pool

- Ingress-buffered architecture implements large, distributed buffer pool to absorb congestion
- Absorbs congestion at all ingress ports contributing to congestion, leveraging all per-port ingress buffer
- Excess traffic does not consume fabric bandwidth, only to be dropped at egress port

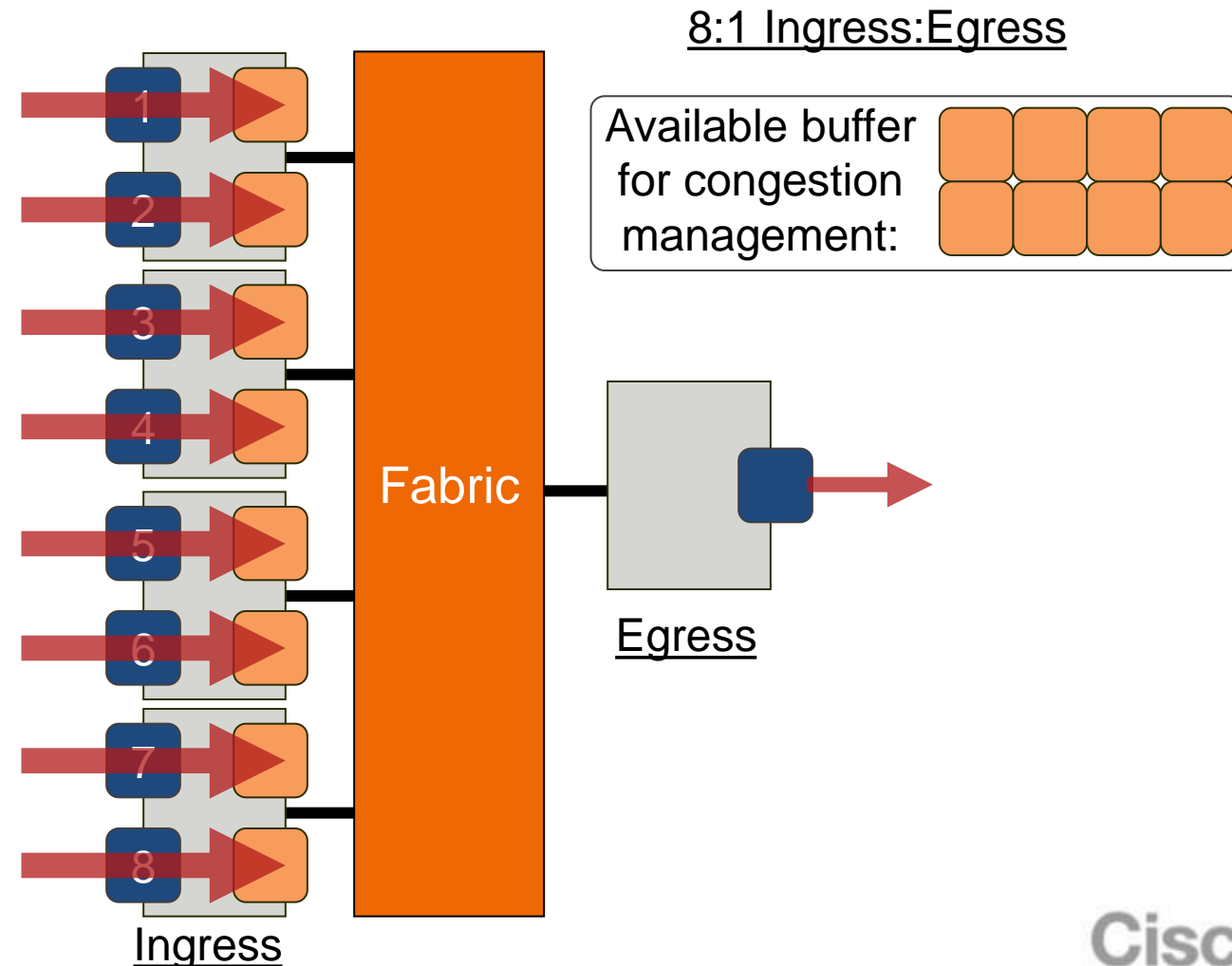
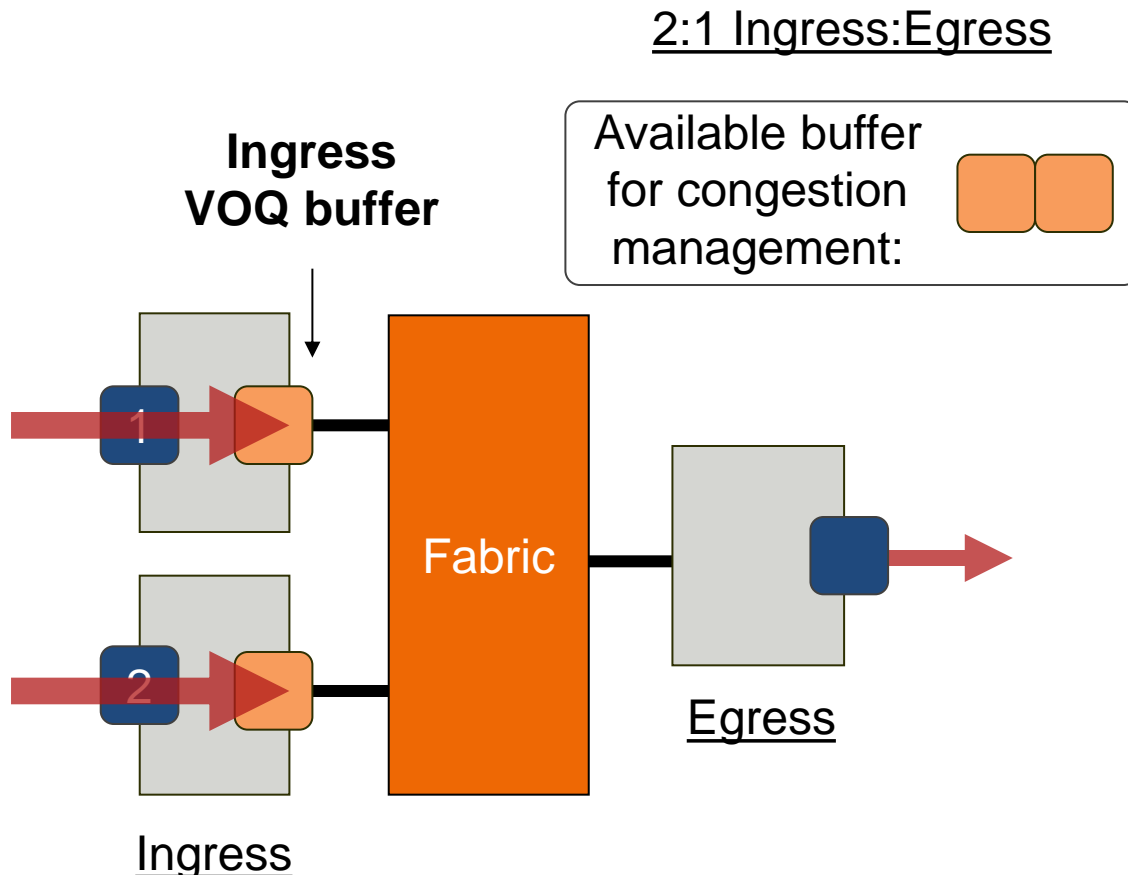

Agenda

- Chassis Architecture
- Supervisor Engine and I/O Module Architecture
- Forwarding Engine Architecture
- Fabric Architecture
- I/O Module Queuing
- **Layer 2 Forwarding**
- IP Forwarding
- Classification
- NetFlow
- Conclusion

Hardware Layer 2 Forwarding Process

MAC table lookup drives Layer 2 forwarding

- Source MAC and destination MAC lookups performed for each frame, based on {VLAN,MAC} pairs
- Source MAC lookup drives new learns and refreshes aging timers
- Destination MAC lookup dictates outgoing switchport



M2 L2 Packet Flow – 10G

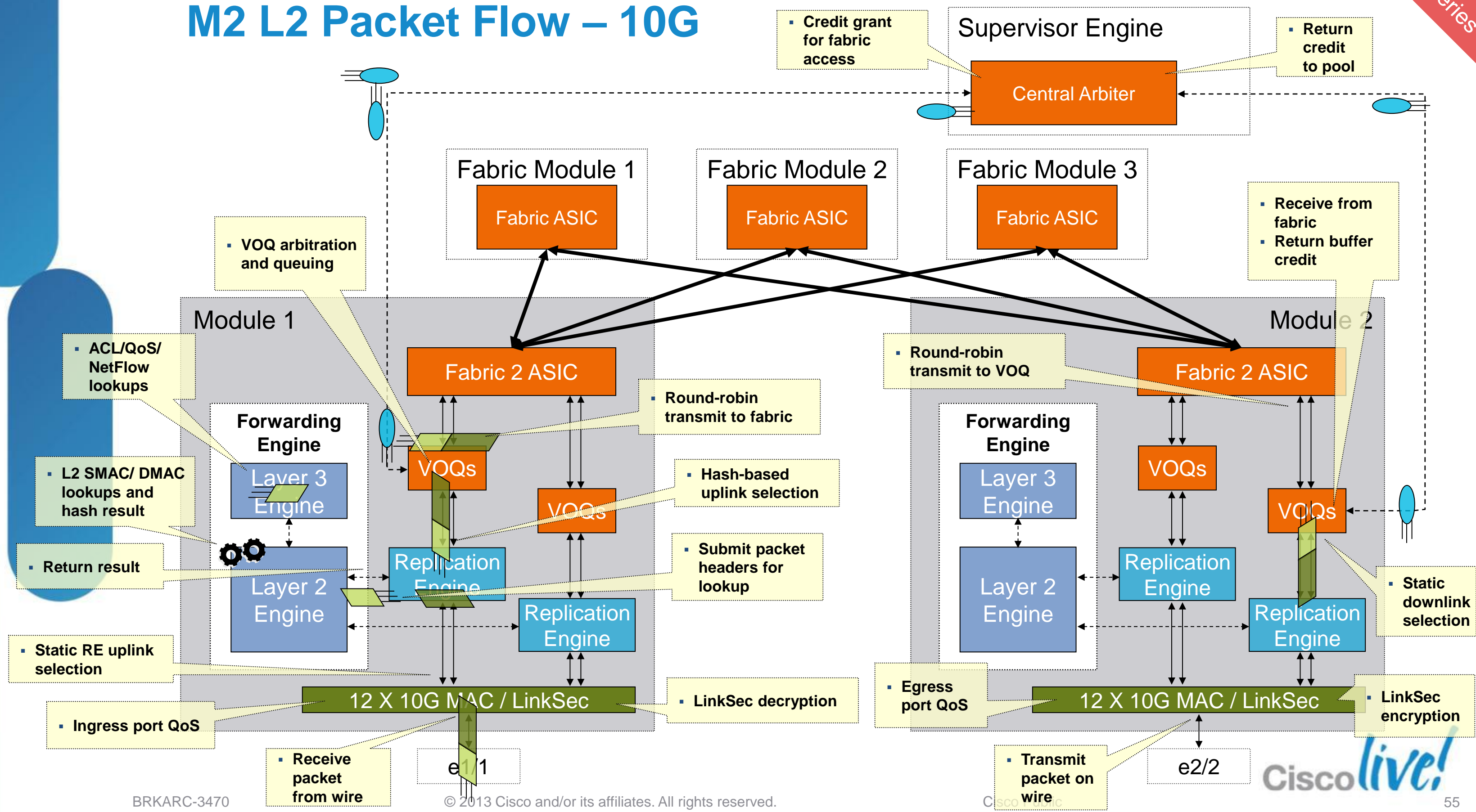

10G M2 Module Ingress Path

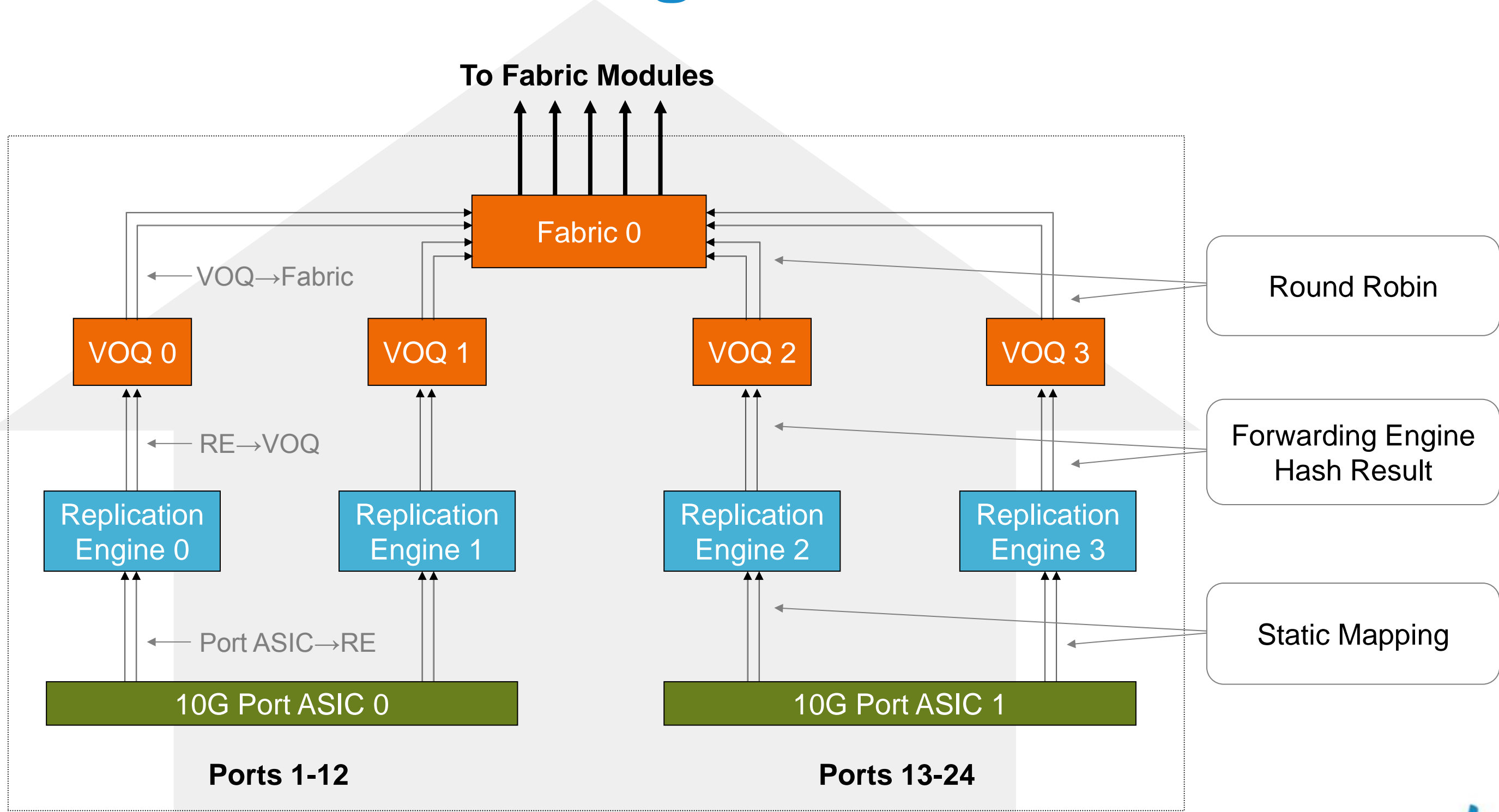

Replication Engine Selection on Ingress

– 10G M2 Module

- Front-panel ports statically mapped to replication engine uplinks

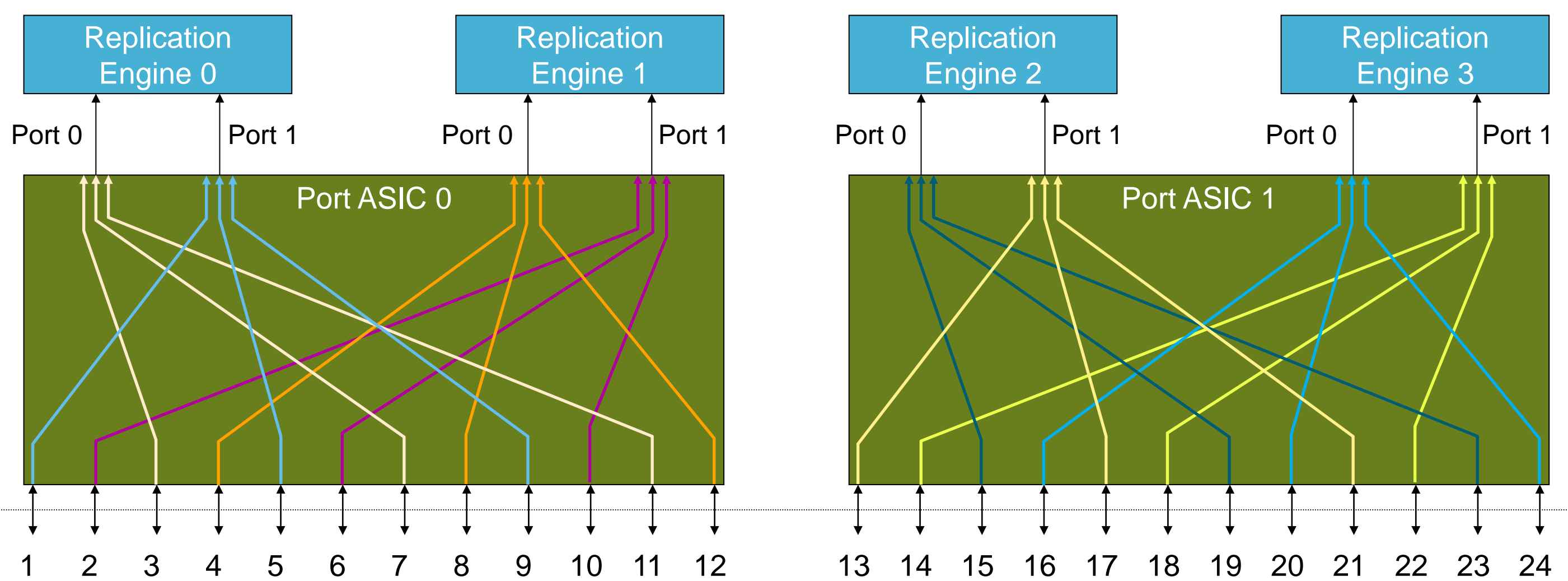

10G M2 Module Egress Path

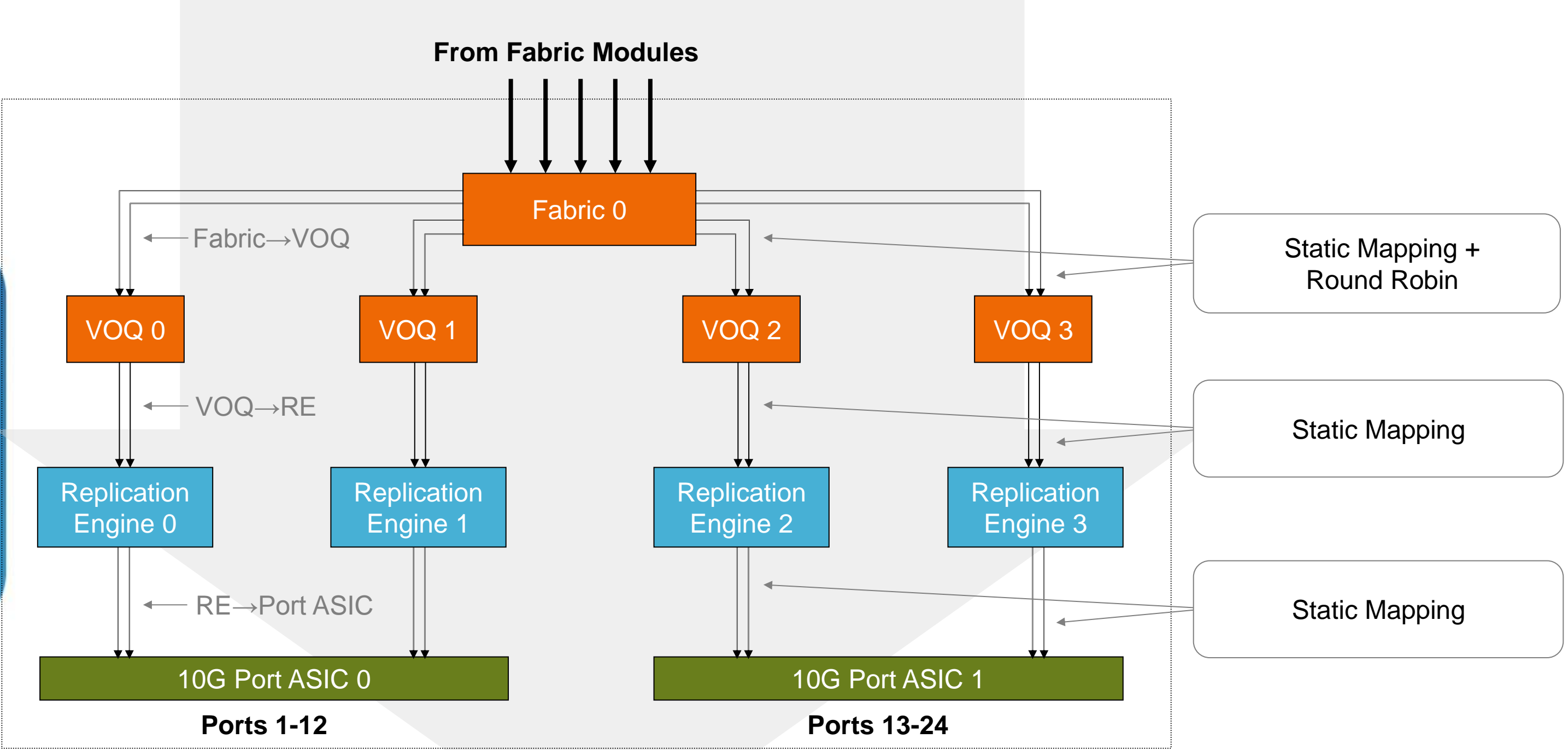

10G M2 Module Egress VQI Mapping

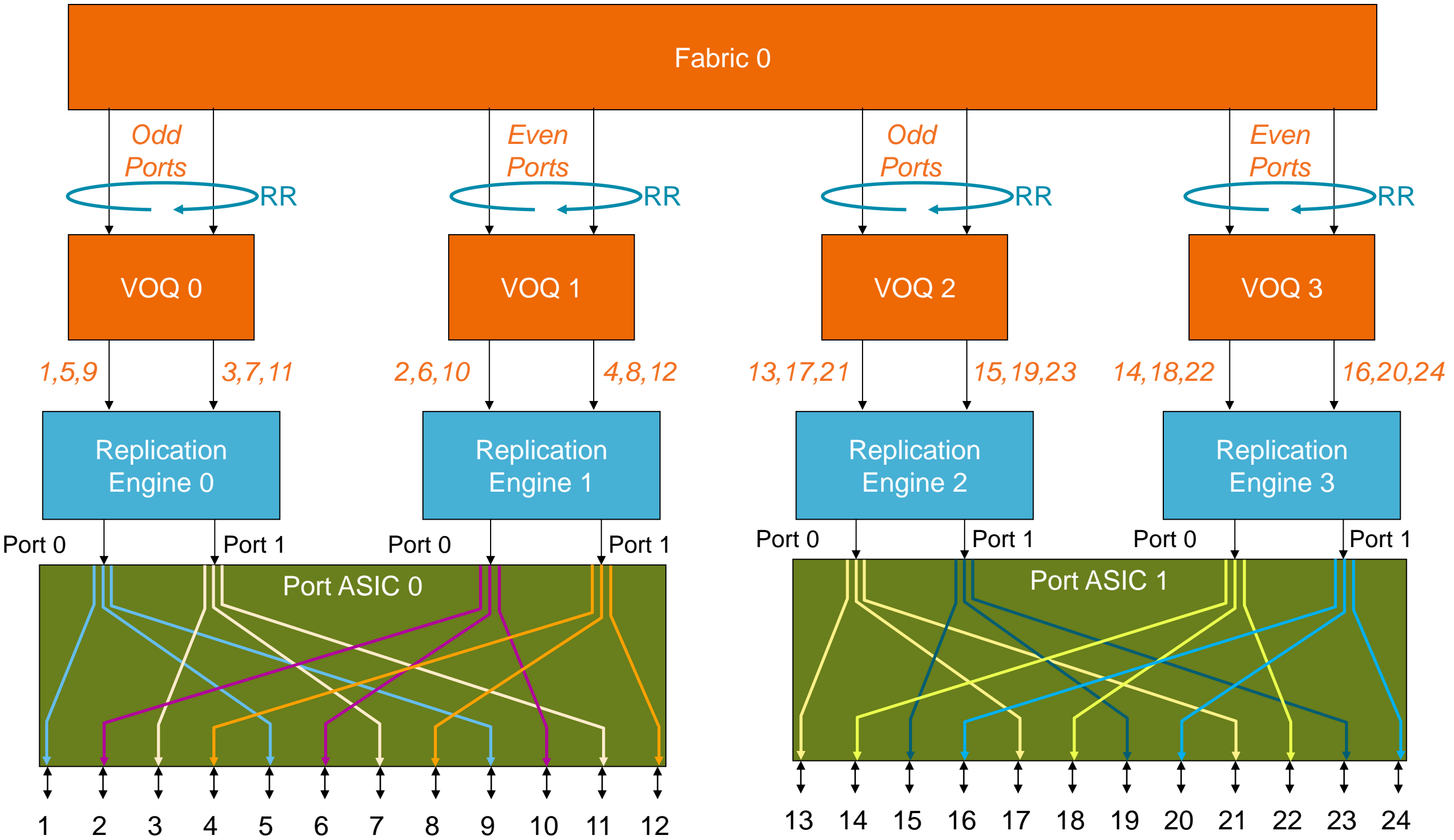

HDR = Packet Headers **DATA** = Packet Data **CTRL** = Internal Signalling

M2 L2 Packet Flow – 40G/100G

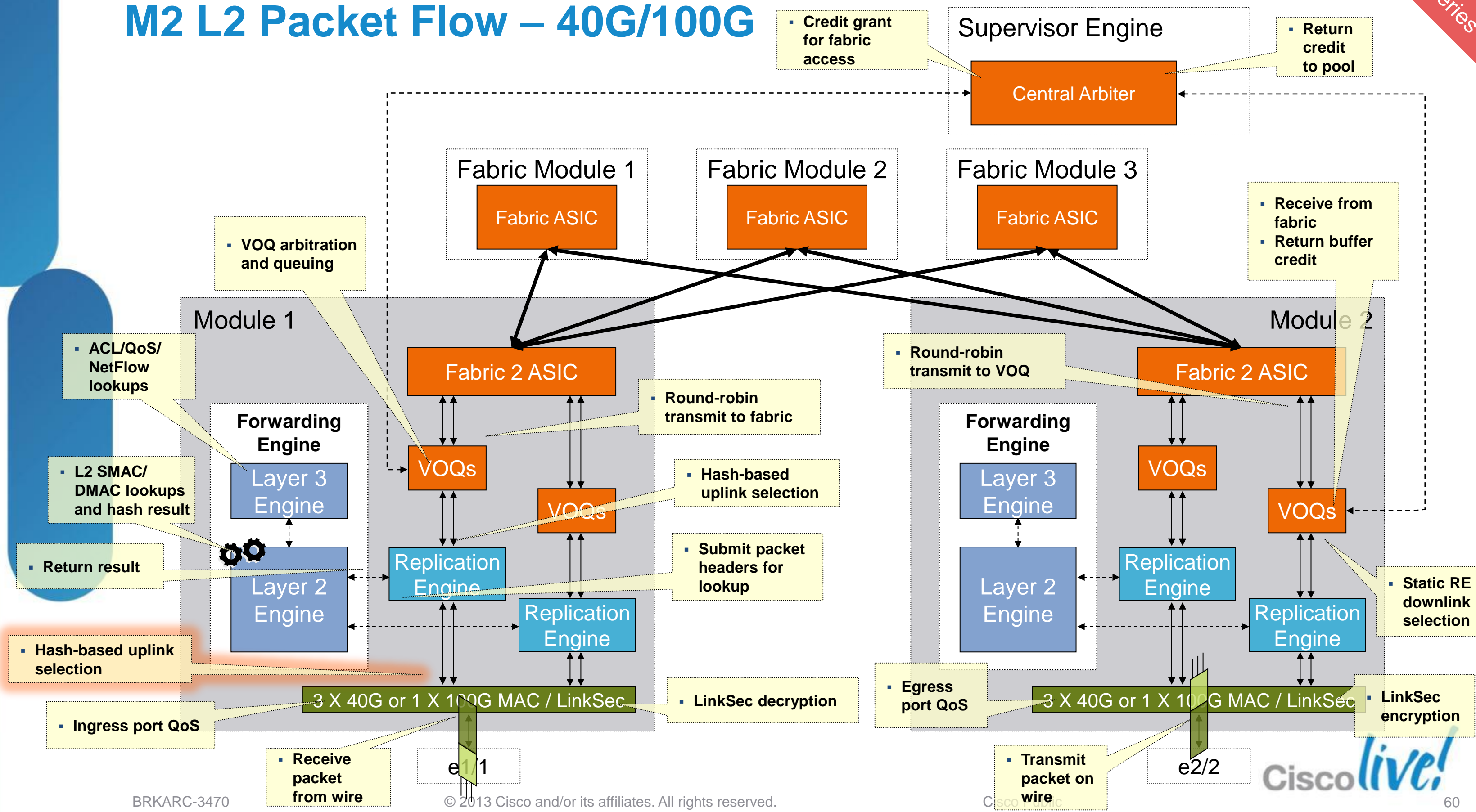

40G / 100G M2 Module Ingress Path

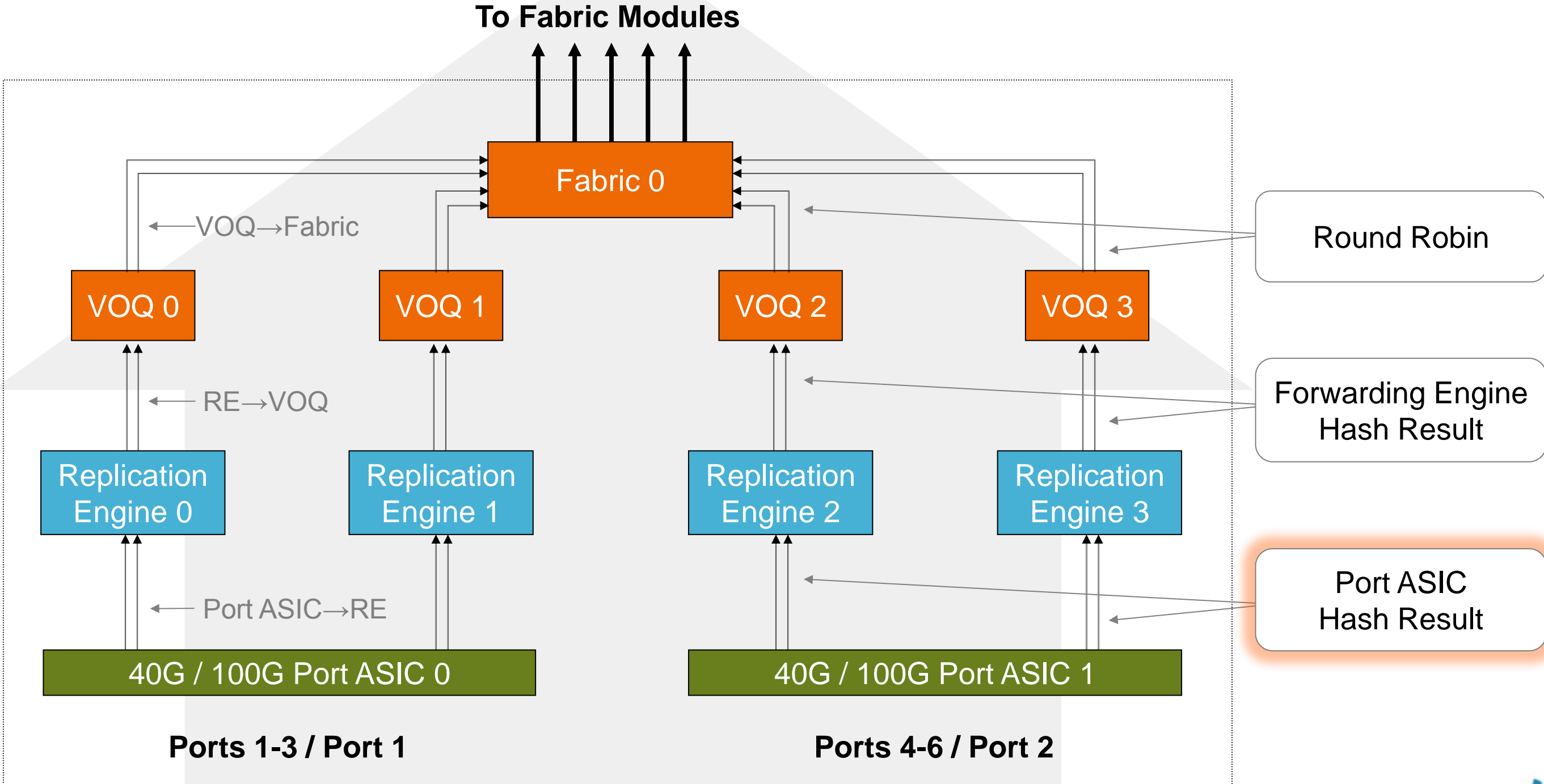

Replication Engine Selection on Ingress

– 40G / 100G M2 Module

- Hash Result generated by Port ASIC selects replication engine uplink
- Hash input uses Layer 3 + Layer 4 information

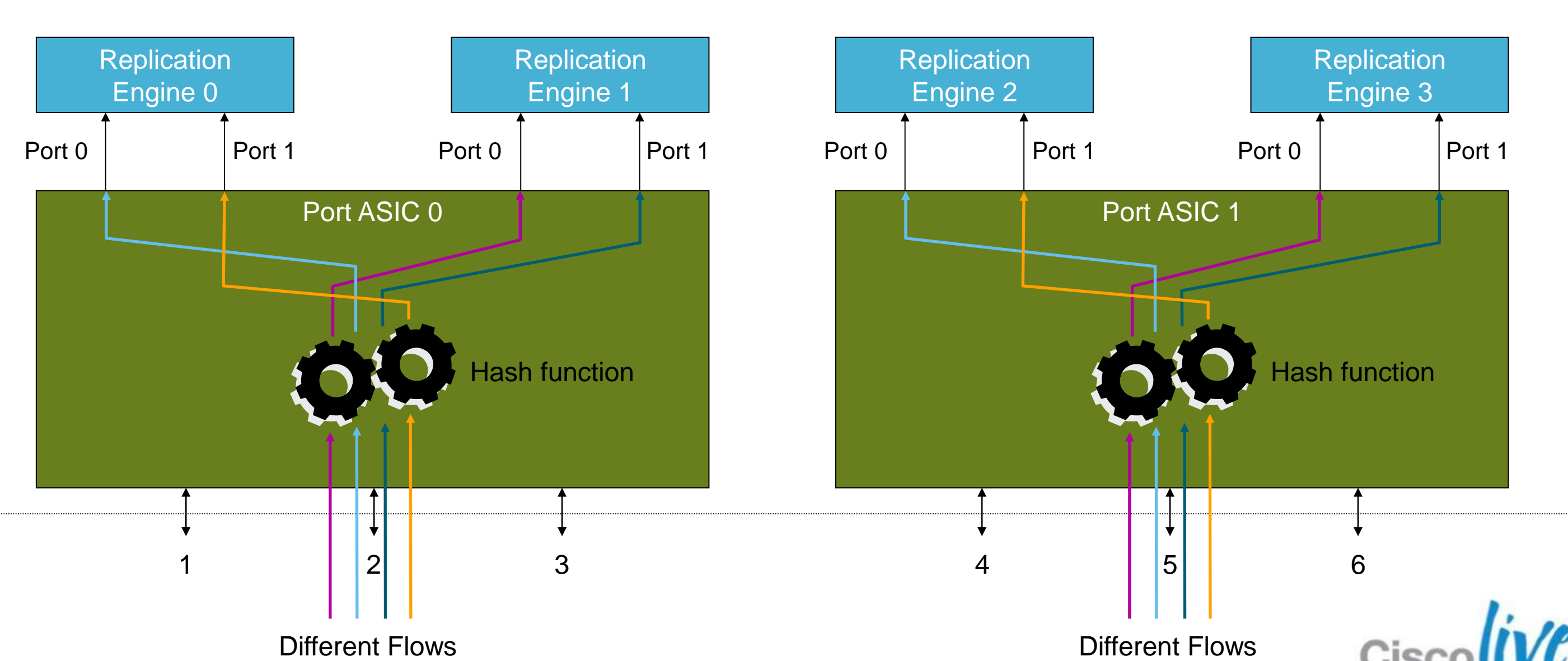

VQI Selection on Ingress – 40G / 100G M2 Module

- Combination of destination port and hash result generated by forwarding engine selects destination VQI for 40G or 100G
- Hash input same as port-channel hash (Layer 3 + Layer 4 by default on M2 modules)

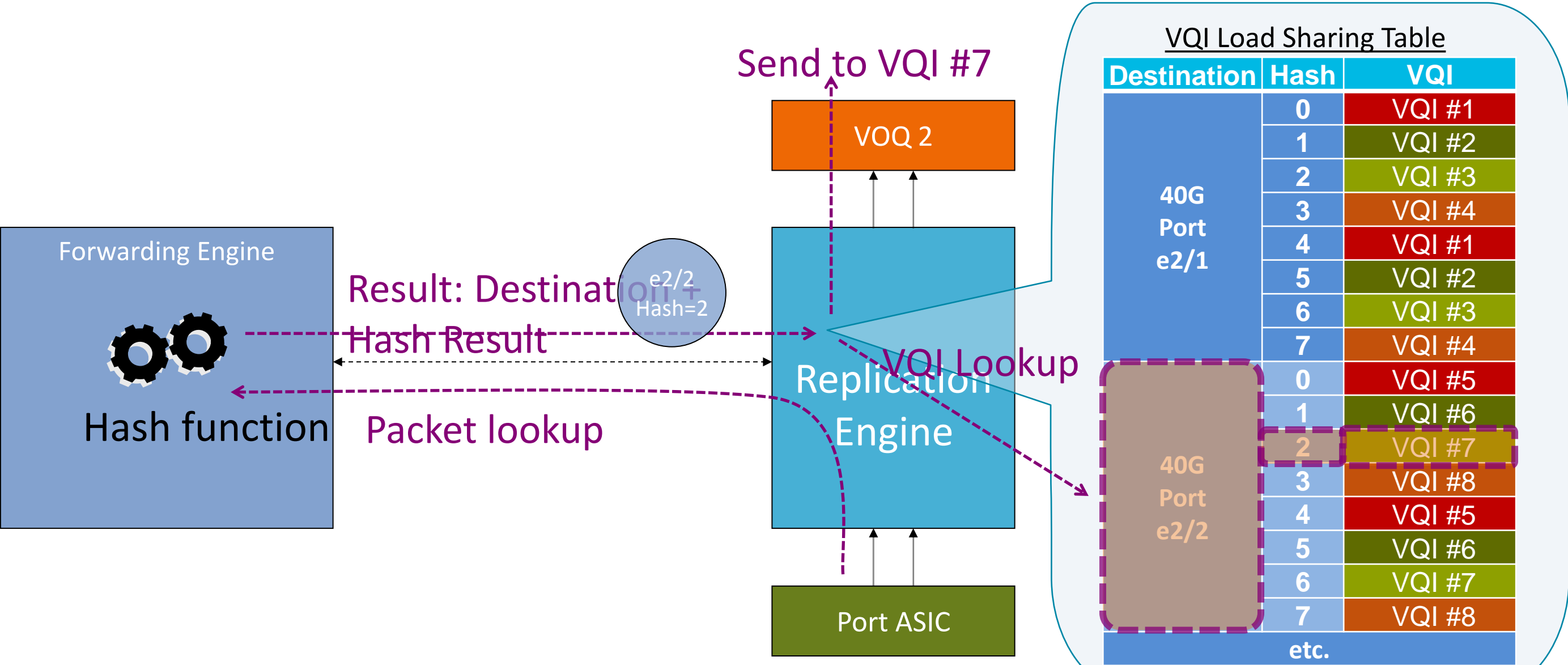

40G / 100G M2 Module Egress Path

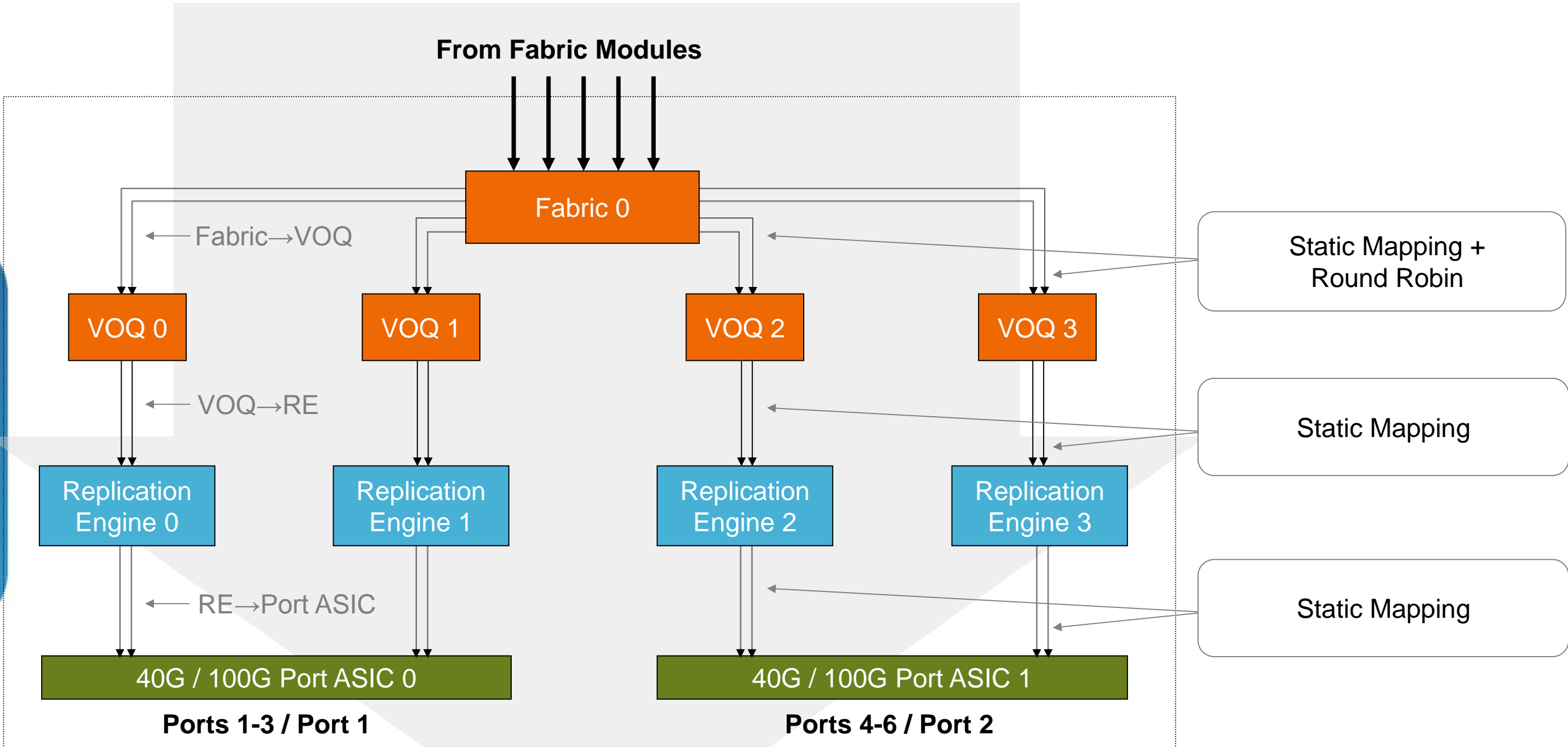

40G / 100G M2 Module Egress VQI Mapping

100G example

40G example

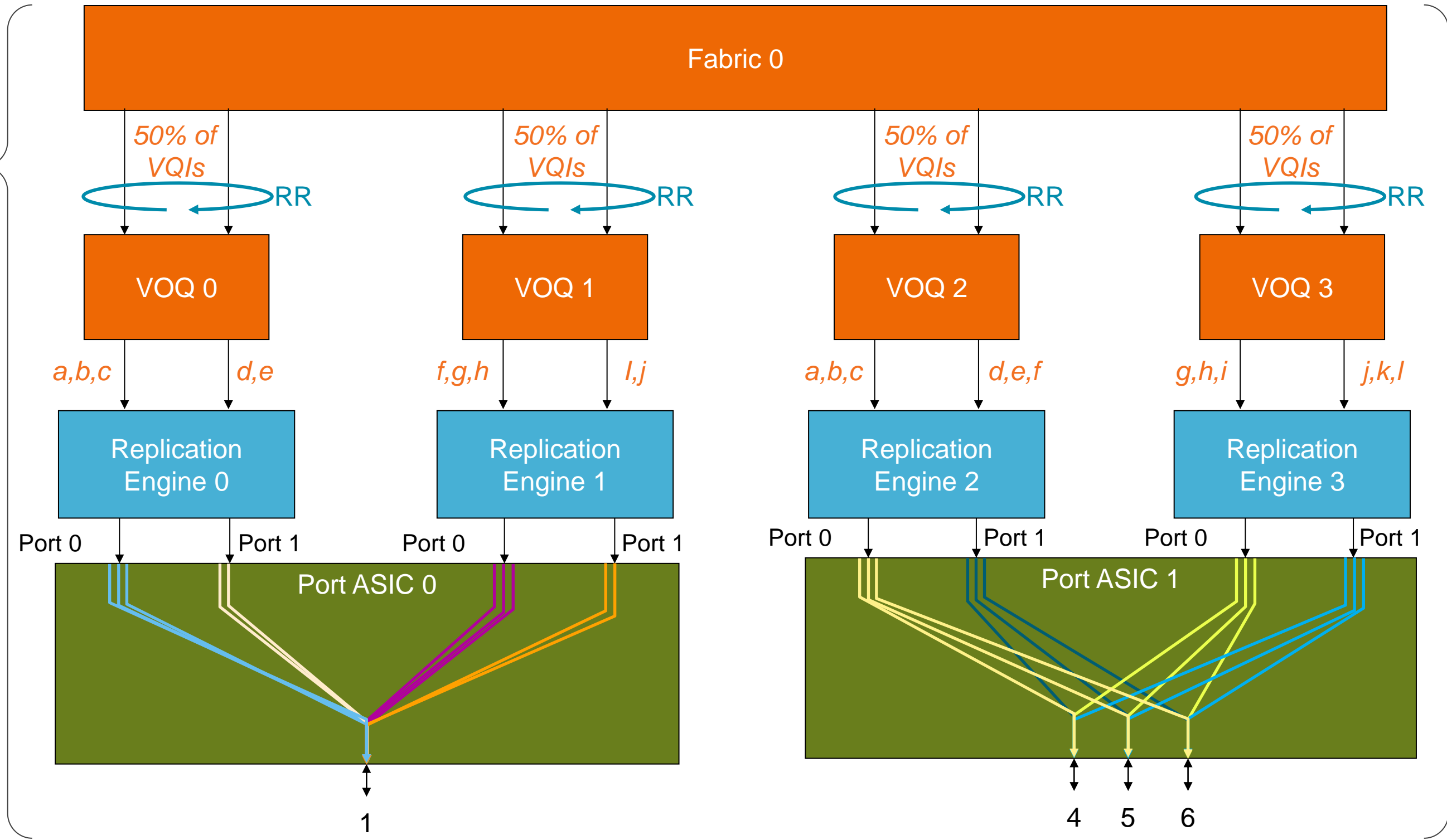

F2 / F2E L2 Packet Flow

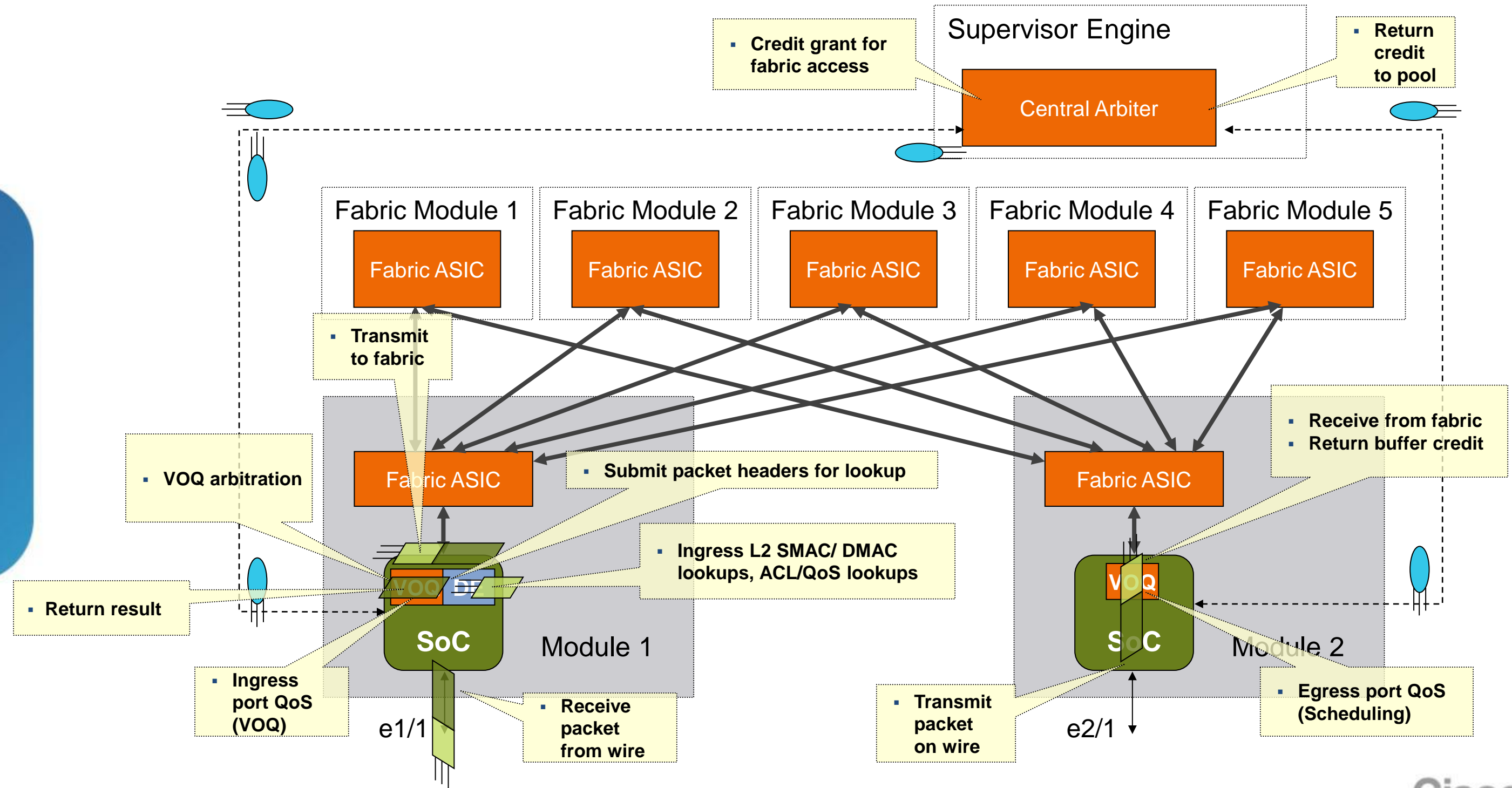

Agenda

- Chassis Architecture
- Supervisor Engine and I/O Module Architecture
- Forwarding Engine Architecture
- Fabric Architecture
- I/O Module Queuing
- Layer 2 Forwarding
- **IP Forwarding**
- Classification
- NetFlow
- Conclusion

IP Forwarding

- Nexus 7000 decouples control plane and data plane
- Forwarding tables built on control plane using routing protocols or static configuration
 - OSPF, EIGRP, IS-IS, RIP, BGP for dynamic routing
- Tables downloaded to forwarding engine hardware for data plane forwarding
 - FIB TCAM contains IP prefixes
 - Adjacency table contains next-hop information



Hardware IP Forwarding Process

- FIB TCAM lookup based on destination prefix (longest-match)
- FIB “hit” returns adjacency, adjacency contains rewrite information (next-hop)
- Pipelined forwarding engine architecture also performs ACL, QoS, and NetFlow lookups, affecting final forwarding result



IPv4 FIB TCAM Lookup (M1/M2)

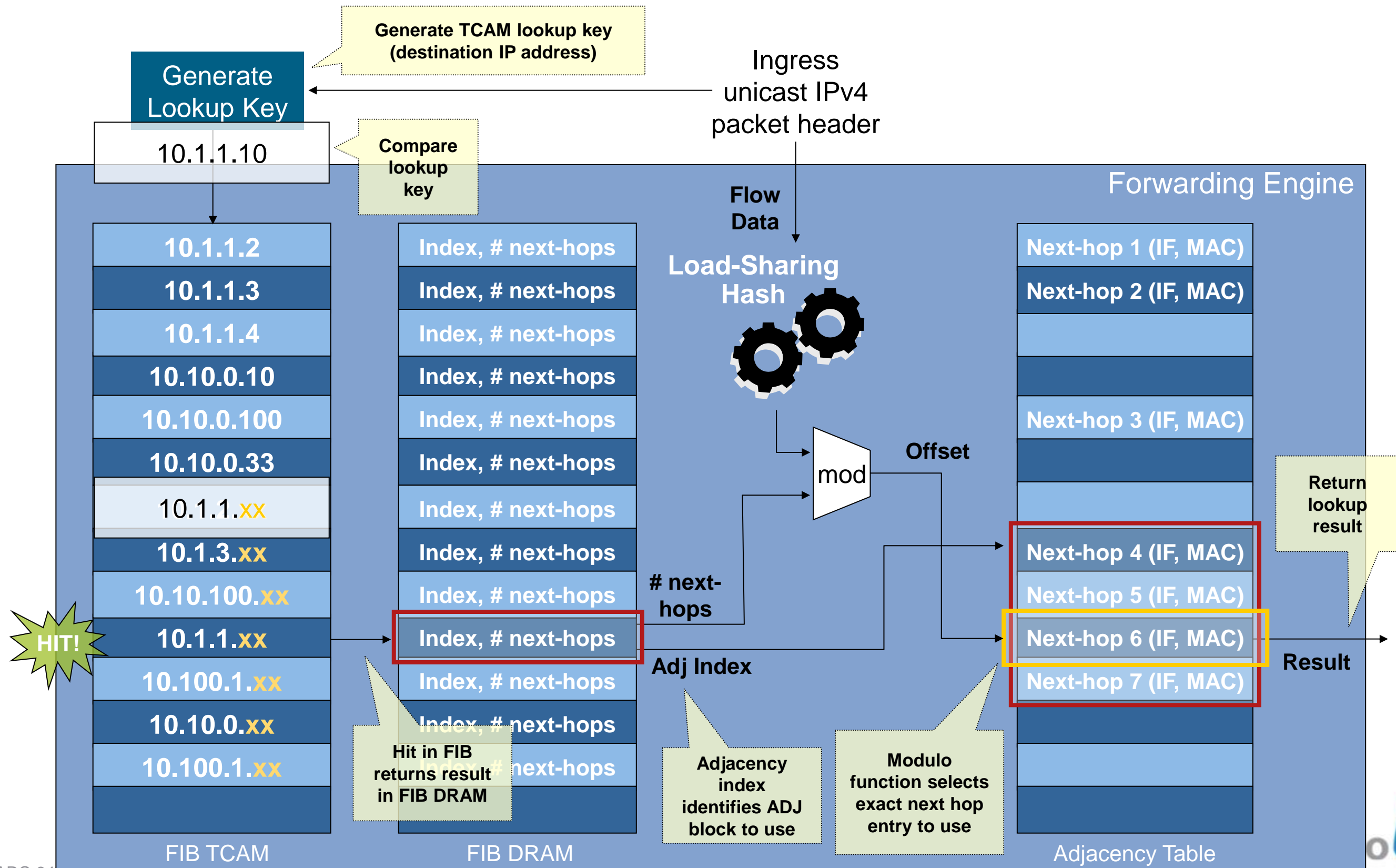

IPv4 FIB TCAM Lookup (F2 / F2E)

Use of Load-Sharing Table decouples prefix entries and adjacency entries

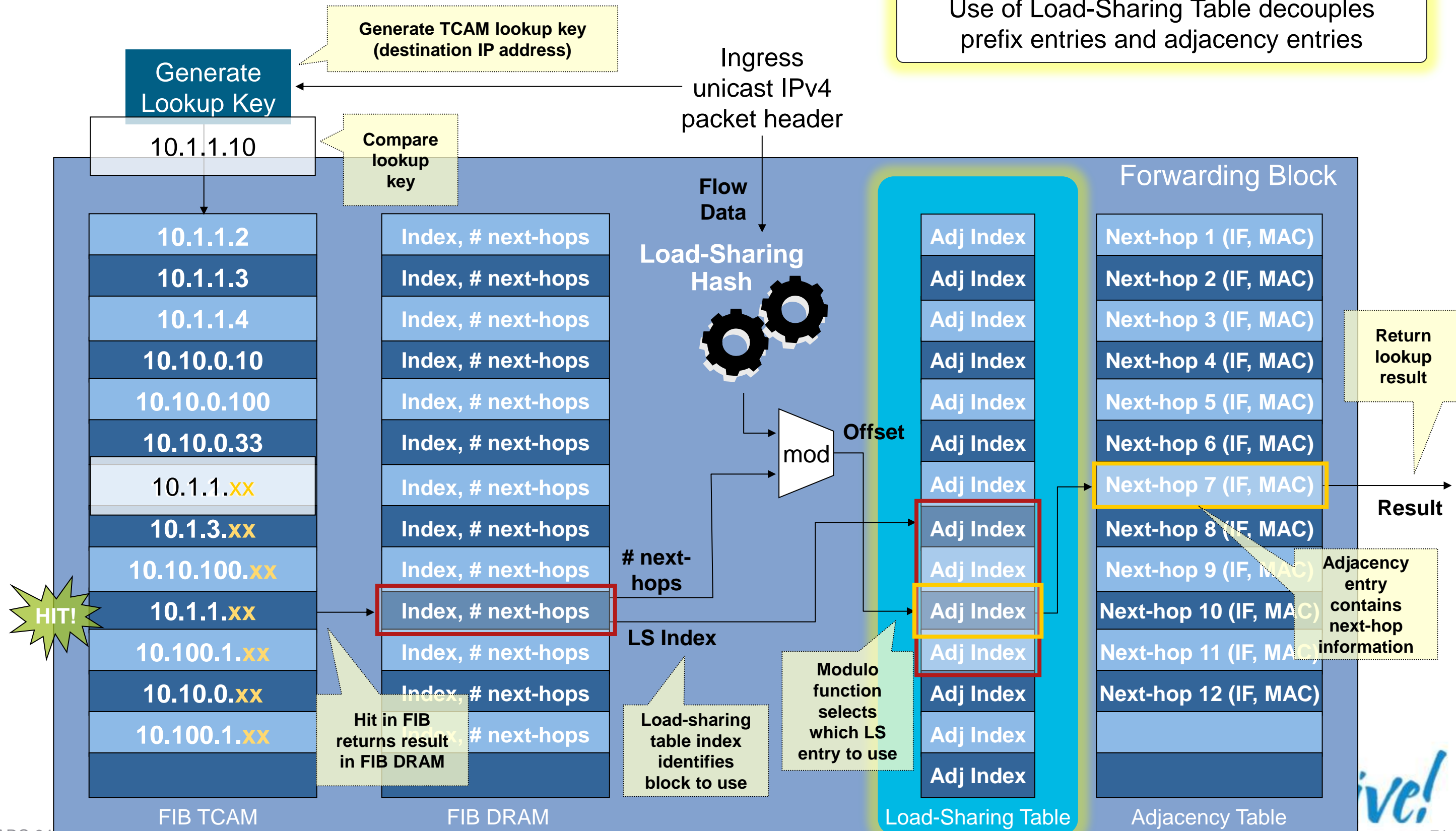

M2 L3 Packet Flow

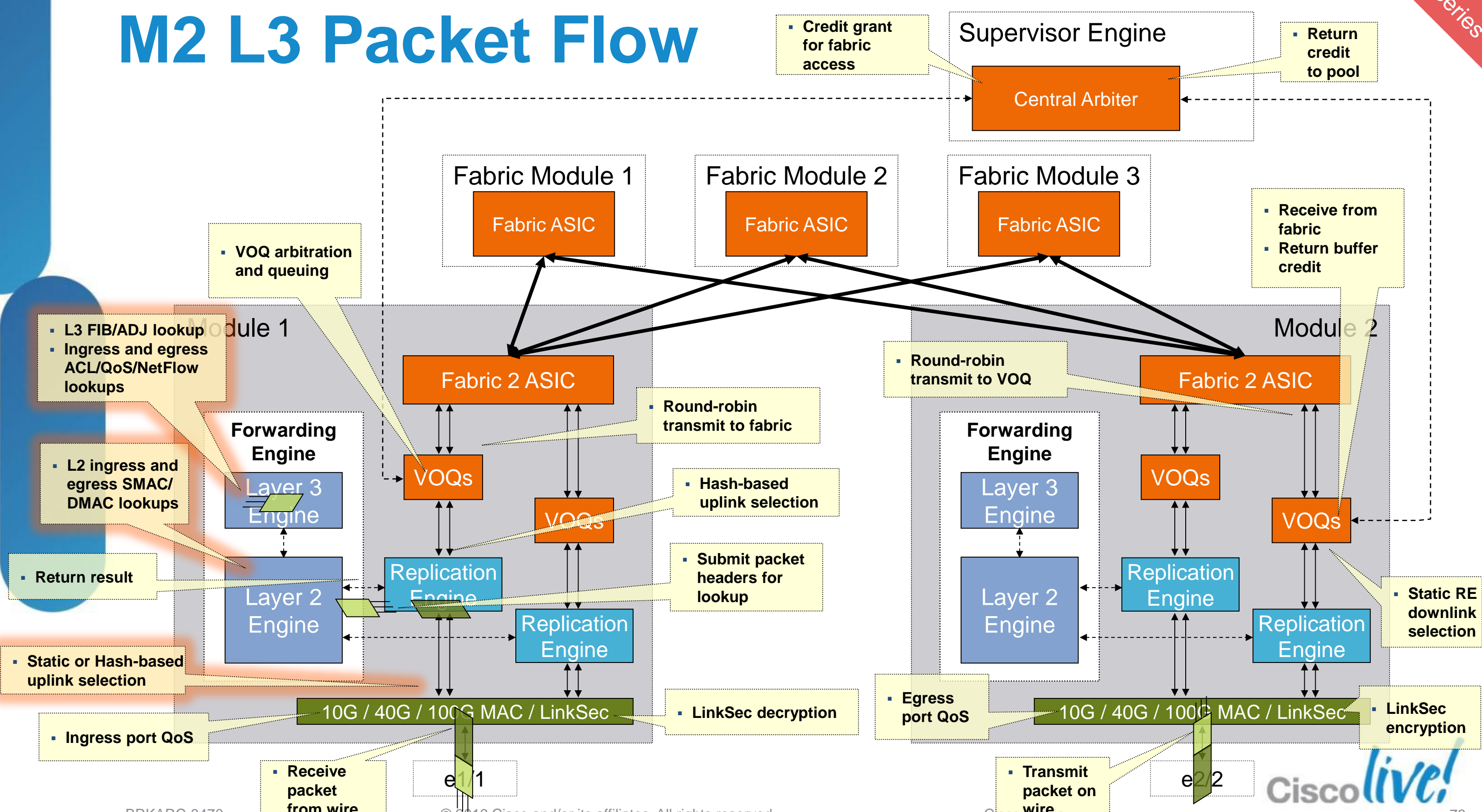

F2 / F2E L3 Packet Flow

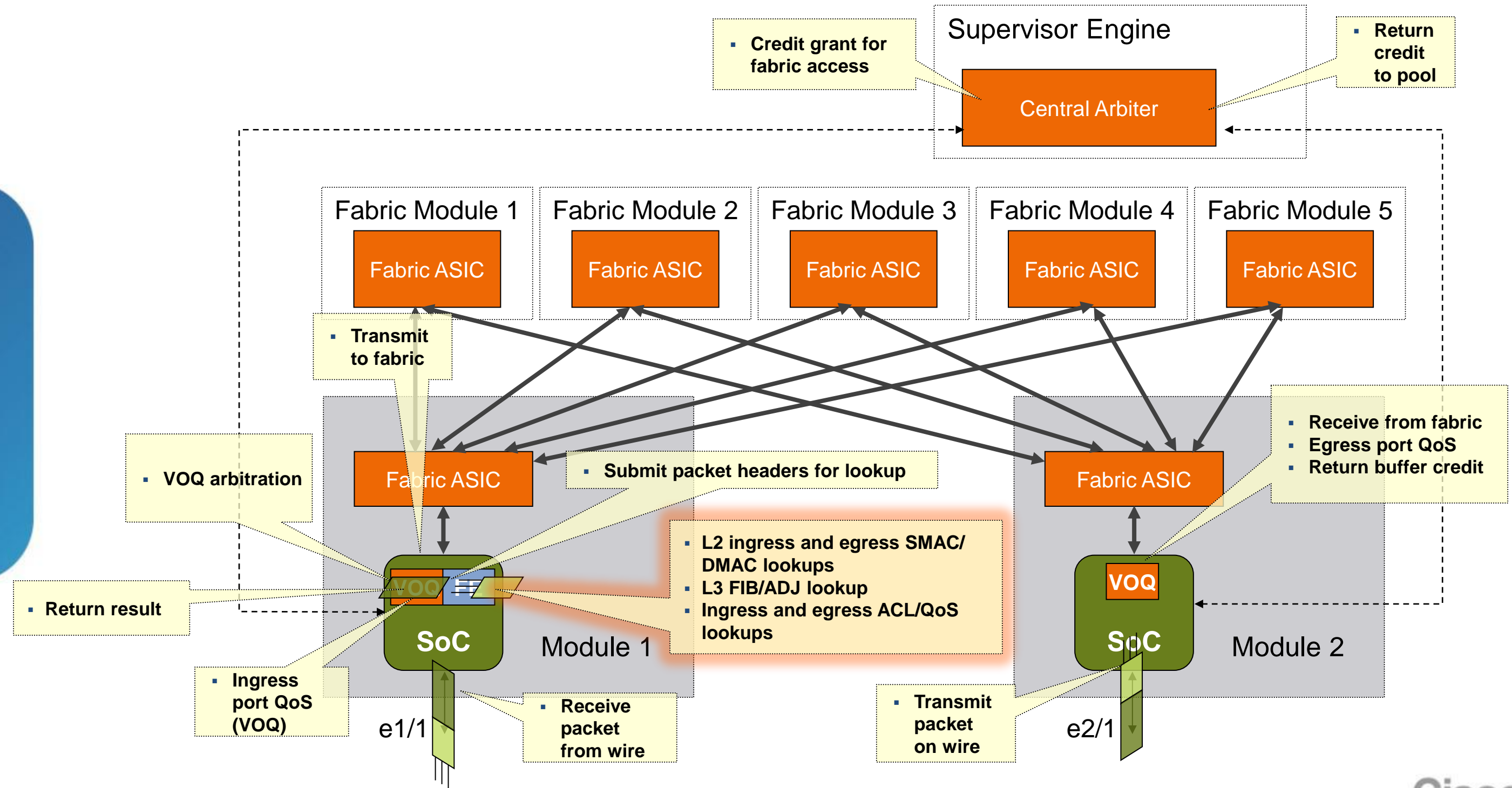

Agenda

- Chassis Architecture
- Supervisor Engine and I/O Module Architecture
- Forwarding Engine Architecture
- Fabric Architecture
- I/O Module Queuing
- Layer 2 Forwarding
- IP Forwarding
- **Classification**
- NetFlow
- Conclusion

What is Classification?



- Matching packets
 - Layer 2, Layer 3, and/or Layer 4 information
- Used to decide whether to apply a particular policy to a packet
 - Enforce security, QoS, or other policies
- Some examples:
 - Match TCP/UDP source/destination port numbers to enforce security policy
 - Match destination IP addresses to apply policy-based routing (PBR)
 - Match 5-tuple to apply marking policy
 - Match protocol-type to apply Control Plane Policing (CoPP)
 - etc.

CL TCAM Lookup – ACL

Security ACL

Packet header:
 SIP: 10.1.1.1
 DIP: 10.2.2.2
 Protocol: TCP
 SPORT: 33992
 DPORT: 80

Generate TCAM lookup key

Generate Lookup Key

SIP | DIP | Pr | SP | DP

```
ip access-list example
permit ip any host 10.1.2.100
deny ip any host 10.1.68.44
deny ip any host 10.33.2.25
permit tcp any any eq 22
deny tcp any any eq 23
deny udp any any eq 514
permit tcp any any eq 80
permit udp any any eq 161
```

Compare lookup key to CL TCAM entries

10.1.1.1 | 10.2.2.2 | tcp | 33992 | 80

XXXXXXXX | 10.2.2.2 | XX | XXX | XXXXX

XXXXXXXX | 10.1.68.44 | XX | XXX | XXX

XXXXXXXX | 10.33.2.25 | XX | XXX | XXX

Comparisons (X = "Mask")

XXXXXXXX | XXXXXXXX | tcp | XXX | 802

XXXXXXXX | XXXXXXXX | tcp | XXX | 23

XXXXXXXX | XXXXXXXX | udp | XXX | 514

HIT!

XXXXXXXX | XXXXXXXX | tcp | XXX | 80

XXXXXXXX | XXXXXXXX | udp | XXX | 161

SIP | DIP | Pr | SP | DP

CL TCAM

Forwarding Engine

- Permit
- Deny
- Deny
- Permit
- Deny
- Deny
- Permit**
- Permit

Results

Hit in CL TCAM returns result in CL SRAM

CL SRAM

Result

Return lookup result

Result affects final packet handling



CL TCAM Lookup – QoS

QoS Classification ACLs

```

ip access-list police
 permit ip any 10.3.3.0/24
 permit ip any 10.4.12.0/24
ip access-list remark-dscp-32
 permit udp 10.1.1.0/24 any
ip access-list remark-dscp-40
 permit tcp 10.1.1.0/24 any
ip access-list remark-prec-3
 permit tcp any 10.5.5.0/24 eq 23
    
```

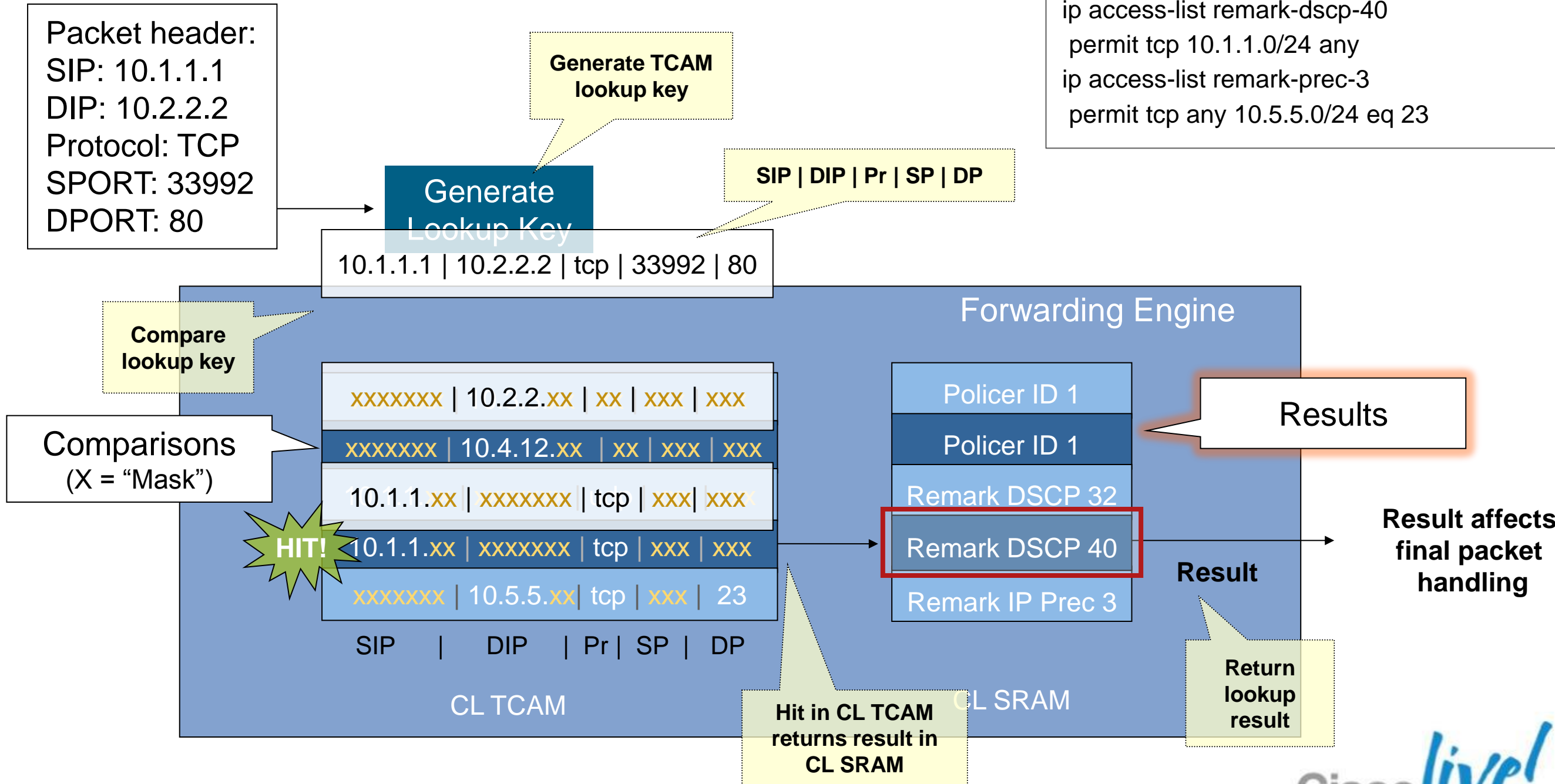

Agenda

- Chassis Architecture
- Supervisor Engine and I/O Module Architecture
- Forwarding Engine Architecture
- Fabric Architecture
- I/O Module Queuing
- Layer 2 Forwarding
- IP Forwarding
- Classification
- **NetFlow**
- Conclusion

NetFlow on Nexus 7000

- NetFlow collects flow data for packets traversing the switch
- Each module maintains independent NetFlow table

	M1 / M2	F2 / F2E
Per-interface NetFlow	Yes	Yes
NetFlow direction	Ingress/Egress	Ingress only
Full NetFlow	Yes	No
Sampled NetFlow	Yes	Yes
Bridged NetFlow	Yes	Yes
Hardware Cache	Yes	No
Software Cache	No	Yes
Hardware Cache Size	512K entries per forwarding engine	N/A
NDE (v5/v9)	Yes	Yes



Full vs. Sampled NetFlow

- NetFlow collects **full** or **sampled** flow data
- **Full NetFlow**: Accounts for every packet of every flow on interface
 - Available on M-Series modules only
 - Flow data collection up to capacity of hardware NetFlow table
- **Sampled NetFlow**: Accounts for M in N packets on interface
 - Available on both M-Series (ingress/egress) and F2/F2E (ingress only)
 - M-Series: Flow data collection up to capacity of hardware NetFlow table
 - F2/F2E: Flow data collection for up to ~1000pps per module

Sampled NetFlow Details

- Random packet-based sampling
- M:N sampling: Out of N consecutive packets, select M consecutive packets and account only for those flows
- On M-Series, sampled packets create hardware NetFlow table entry
- On F2/F2E, sampled packets sent to LC CPU via module inband
 - Rate limited to ~1000pps per module
- Software multiplies configured sampler rate by 100 on F2/F2E modules
 - Example: when using 1 out-of 100 sampler on F2/F2E interface, sampled rate becomes 1:10000

NetFlow on M1/M2 Modules

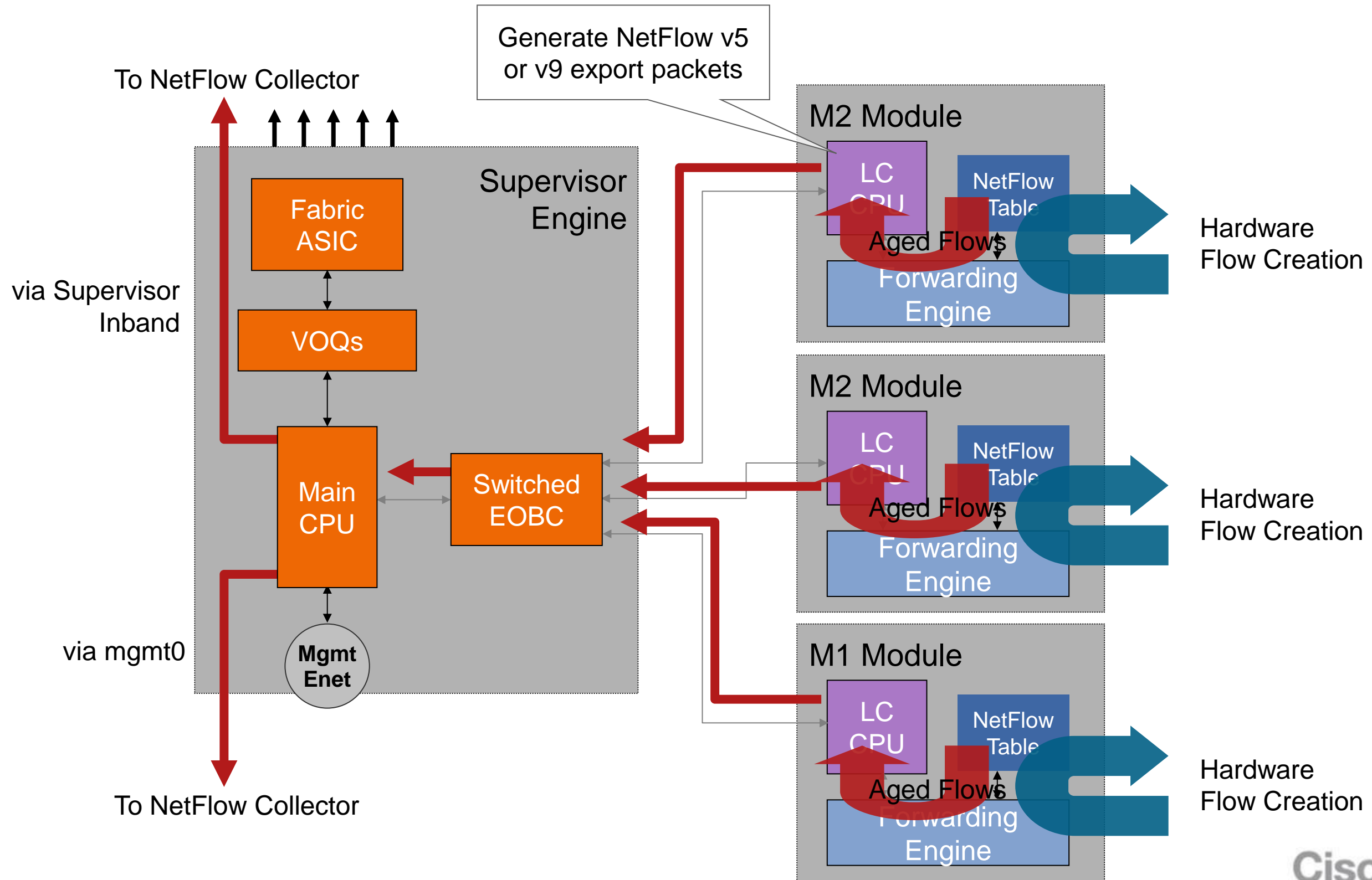

Sampled NetFlow on F2/F2E Modules

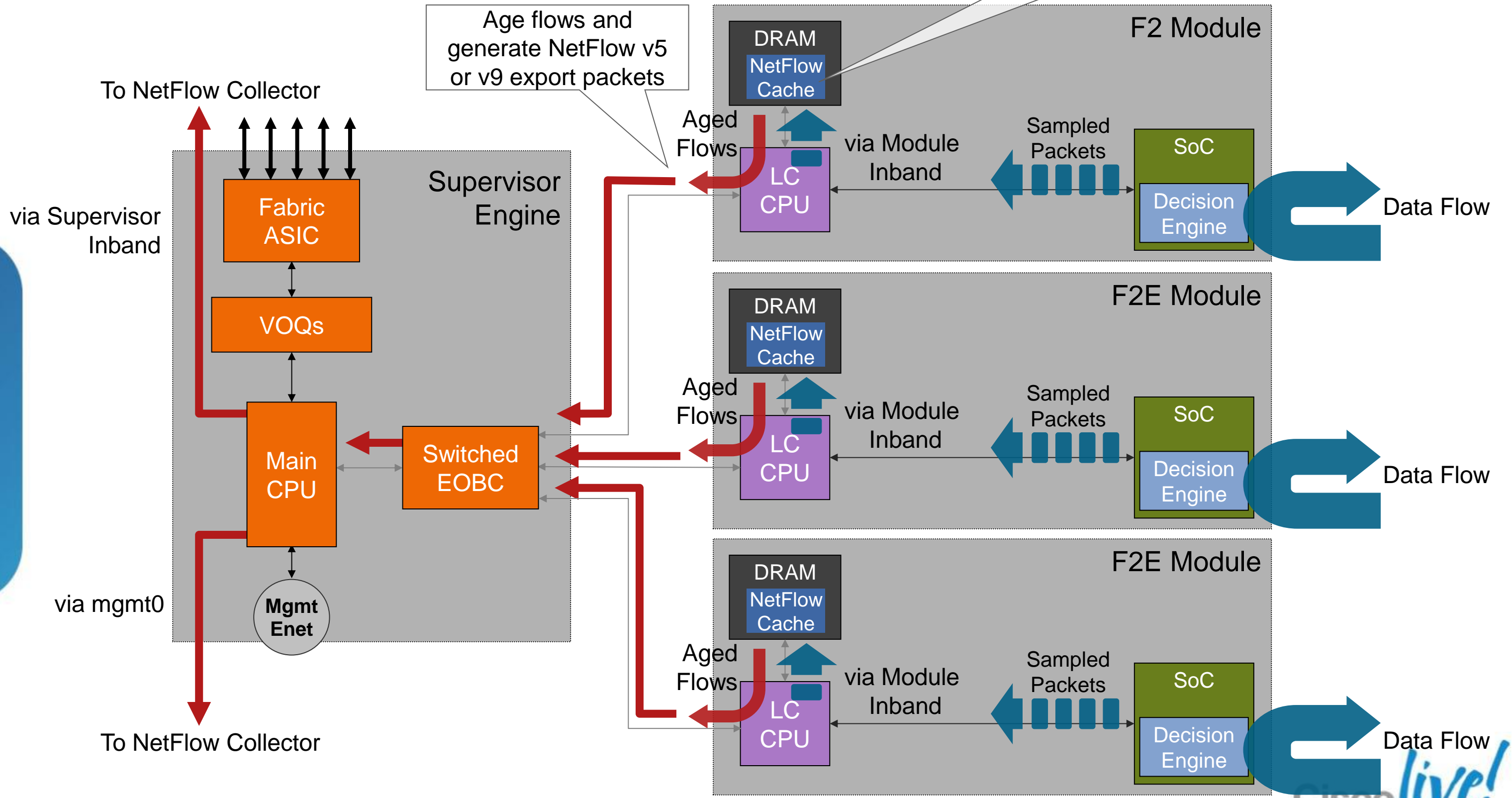

Agenda

- Chassis Architecture
- Supervisor Engine and I/O Module Architecture
- Forwarding Engine Architecture
- Fabric Architecture
- I/O Module Queuing
- Layer 2 Forwarding
- IP Forwarding
- Classification
- NetFlow
- **Conclusion**

Nexus 7000 Architecture Summary

Control plane protocols, system and network management

Multiple chassis designs with density and airflow options

Supervisor Engines

I/O Modules

Chassis

Fabrics

Variety of front-panel interface and transceiver types with hardware-based forwarding and services, including unicast/multicast, bridging/routing, ACL/QoS classification, and NetFlow statistics

High-bandwidth fabric to interconnect I/O modules and provide investment protection



Conclusion

- You should now have a thorough understanding of the Nexus 7000 switching architecture, I/O module design, packet flows, and key forwarding engine functions...
- **Any questions?**



Q & A



Complete Your Online Session Evaluation

Give us your feedback and receive a Cisco Live 2013 Polo Shirt!

Complete your Overall Event Survey and 5 Session Evaluations.

- Directly from your mobile device on the Cisco Live Mobile App
- By visiting the Cisco Live Mobile Site www.ciscoliveaustralia.com/mobile
- Visit any Cisco Live Internet Station located throughout the venue

Polo Shirts can be collected in the World of Solutions on Friday 8 March 12:00pm-2:00pm



Cisco *live!* 365

Don't forget to activate your Cisco Live 365 account for access to all session material,

communities, and on-demand and live activities throughout the year. Log into your Cisco Live portal and click the "Enter Cisco Live 365" button.

www.ciscoliveaustralia.com/portal/login.wv

Cisco *live!*

