



Cisco Nexus 9396PX NX-OS Mode Switch Hardware Installation Guide

First Published: 2014-03-17

Last Modified: 2017-11-13

Americas Headquarters

Cisco Systems, Inc.
170 West Tasman Drive
San Jose, CA 95134-1706
USA
<http://www.cisco.com>
Tel: 408 526-4000
800 553-NETS (6387)
Fax: 408 527-0883

THE SPECIFICATIONS AND INFORMATION REGARDING THE PRODUCTS IN THIS MANUAL ARE SUBJECT TO CHANGE WITHOUT NOTICE. ALL STATEMENTS, INFORMATION, AND RECOMMENDATIONS IN THIS MANUAL ARE BELIEVED TO BE ACCURATE BUT ARE PRESENTED WITHOUT WARRANTY OF ANY KIND, EXPRESS OR IMPLIED. USERS MUST TAKE FULL RESPONSIBILITY FOR THEIR APPLICATION OF ANY PRODUCTS.

THE SOFTWARE LICENSE AND LIMITED WARRANTY FOR THE ACCOMPANYING PRODUCT ARE SET FORTH IN THE INFORMATION PACKET THAT SHIPPED WITH THE PRODUCT AND ARE INCORPORATED HEREIN BY THIS REFERENCE. IF YOU ARE UNABLE TO LOCATE THE SOFTWARE LICENSE OR LIMITED WARRANTY, CONTACT YOUR CISCO REPRESENTATIVE FOR A COPY.

The following information is for FCC compliance of Class A devices: This equipment has been tested and found to comply with the limits for a Class A digital device, pursuant to part 15 of the FCC rules. These limits are designed to provide reasonable protection against harmful interference when the equipment is operated in a commercial environment. This equipment generates, uses, and can radiate radio-frequency energy and, if not installed and used in accordance with the instruction manual, may cause harmful interference to radio communications. Operation of this equipment in a residential area is likely to cause harmful interference, in which case users will be required to correct the interference at their own expense.

The following information is for FCC compliance of Class B devices: This equipment has been tested and found to comply with the limits for a Class B digital device, pursuant to part 15 of the FCC rules. These limits are designed to provide reasonable protection against harmful interference in a residential installation. This equipment generates, uses and can radiate radio frequency energy and, if not installed and used in accordance with the instructions, may cause harmful interference to radio communications. However, there is no guarantee that interference will not occur in a particular installation. If the equipment causes interference to radio or television reception, which can be determined by turning the equipment off and on, users are encouraged to try to correct the interference by using one or more of the following measures:

- Reorient or relocate the receiving antenna.
- Increase the separation between the equipment and receiver.
- Connect the equipment into an outlet on a circuit different from that to which the receiver is connected.
- Consult the dealer or an experienced radio/TV technician for help.

Modifications to this product not authorized by Cisco could void the FCC approval and negate your authority to operate the product

The Cisco implementation of TCP header compression is an adaptation of a program developed by the University of California, Berkeley (UCB) as part of UCB's public domain version of the UNIX operating system. All rights reserved. Copyright © 1981, Regents of the University of California.

NOTWITHSTANDING ANY OTHER WARRANTY HEREIN, ALL DOCUMENT FILES AND SOFTWARE OF THESE SUPPLIERS ARE PROVIDED "AS IS" WITH ALL FAULTS. CISCO AND THE ABOVE-NAMED SUPPLIERS DISCLAIM ALL WARRANTIES, EXPRESSED OR IMPLIED, INCLUDING, WITHOUT LIMITATION, THOSE OF MERCHANTABILITY, FITNESS FOR A PARTICULAR PURPOSE AND NONINFRINGEMENT OR ARISING FROM A COURSE OF DEALING, USAGE, OR TRADE PRACTICE.

IN NO EVENT SHALL CISCO OR ITS SUPPLIERS BE LIABLE FOR ANY INDIRECT, SPECIAL, CONSEQUENTIAL, OR INCIDENTAL DAMAGES, INCLUDING, WITHOUT LIMITATION, LOST PROFITS OR LOSS OR DAMAGE TO DATA ARISING OUT OF THE USE OR INABILITY TO USE THIS MANUAL, EVEN IF CISCO OR ITS SUPPLIERS HAVE BEEN ADVISED OF THE POSSIBILITY OF SUCH DAMAGES.

Any Internet Protocol (IP) addresses and phone numbers used in this document are not intended to be actual addresses and phone numbers. Any examples, command display output, network topology diagrams, and other figures included in the document are shown for illustrative purposes only. Any use of actual IP addresses or phone numbers in illustrative content is unintentional and coincidental.

Cisco and the Cisco logo are trademarks or registered trademarks of Cisco and/or its affiliates in the U.S. and other countries. To view a list of Cisco trademarks, go to this URL: [www.cisco.com go trademarks](http://www.cisco.com/go/trademarks). Third-party trademarks mentioned are the property of their respective owners. The use of the word partner does not imply a partnership relationship between Cisco and any other company. (1721R)

© 2014–2017 Cisco Systems, Inc. All rights reserved.



CONTENTS

Trademarks ?

PREFACE

Preface vii

Audience vii

Documentation Conventions vii

Related Documentation for Cisco Nexus 9000 Series NX-OS Software viii

Documentation Feedback x

Obtaining Documentation and Submitting a Service Request x

CHAPTER 1

Overview 1

Overview 1

CHAPTER 2

Preparing the Site 7

Temperature Requirements 7

Humidity Requirements 7

Altitude Requirements 7

Dust and Particulate Requirements 8

Minimizing Electromagnetic and Radio Frequency Interference 8

Shock and Vibration Requirements 9

Grounding Requirements 9

Planning for Power Requirements 9

Airflow Requirements 10

Rack and Cabinet Requirements 11

Clearance Requirements 12

CHAPTER 3

Installing the Chassis 15

| | |
|--|----|
| Installation Options with Rack-Mount Kits, Racks, and Cabinets | 15 |
| Install a Rack | 16 |
| Unpacking and Inspecting a New Switch | 16 |
| Planning How to Position the Chassis in the Rack | 18 |
| Installing the Chassis in a Two-Post Rack | 18 |
| Attaching Center-Mount Brackets to the Chassis | 19 |
| Installing the Chassis in a Two-Post Rack | 20 |
| Installing the Chassis in a Four-Post Rack | 21 |
| Installing the Switch using the N9K-C9300-RMK Rack-mount Kit | 22 |
| Attaching the Bottom-Support Rails to the Rack | 22 |
| Attaching Front-Mount Brackets to the Chassis | 24 |
| Installing the Chassis in a Four-Post Rack | 25 |
| Grounding the Chassis | 27 |
| Powering Up the Switch | 28 |

CHAPTER 4

| | |
|---|-----------|
| Connecting the Switch to the Network | 33 |
| Setting Up the Management Interface | 33 |
| Uplink Connections | 33 |
| Downlink Connections | 34 |
| Guidelines for Connecting Ports | 34 |
| Maintaining Transceivers and Optical Cables | 35 |

CHAPTER 5

| | |
|---|-----------|
| Replacing Modules | 37 |
| Replacing the Uplink Module | 37 |
| Replacing a Fan Module During Operations | 38 |
| Replacing a Power Supply Module | 40 |
| Removing an AC Power Supply | 40 |
| Removing an HVAC/HVDC Power Supply | 41 |
| Removing a DC Power Supply | 42 |
| Installing an AC Power Supply | 42 |
| Installing an HVAC/HVDC Power Supply | 43 |
| Installing a DC Power Supply | 44 |
| Wiring a 48 V DC Electrical Connector Block | 45 |

| | | |
|-------------------|--|-----------|
| APPENDIX A | Rack Specifications | 47 |
| | Overview of Racks | 47 |
| | General Requirements for Cabinets and Racks | 47 |
| | Requirements Specific to Standard Open Racks | 48 |
| | Requirements Specific to Perforated Cabinets | 48 |
| | Cable Management Guidelines | 48 |

| | | |
|-------------------|--|-----------|
| APPENDIX B | System Specifications | 49 |
| | Environmental Specifications | 49 |
| | Switch Dimensions | 49 |
| | Switch and Module Weights and Quantities | 50 |
| | Transceiver and Cable Specifications | 51 |
| | Switch Power Input Requirements | 51 |
| | Power Specifications | 51 |
| | 650-W AC Power Supply Specifications | 51 |
| | 1200-W HVAC/HVDC Power Supply Specifications | 52 |
| | 930-W DC Power Supply (Port-Side Intake) Specifications | 53 |
| | 930-W DC Power Supply (Port-Side Exhaust) Specifications | 53 |
| | Power Cable Specifications | 54 |
| | AC Power Cables Supported by NX-OS Mode Switches | 54 |
| | HVAC/HVDC Power Cables Supported by ACI-Mode and NX-OS Mode Switches | 55 |
| | DC Power Cable Specifications | 56 |
| | Regulatory Standards Compliance Specifications | 56 |

| | | |
|-------------------|---------------------|-----------|
| APPENDIX C | LEDs | 59 |
| | Switch Chassis LEDs | 59 |
| | Uplink Module LEDs | 60 |
| | Fan Module LEDs | 60 |
| | Power Supply LEDs | 61 |

| | | |
|-------------------|------------------------------|-----------|
| APPENDIX D | Additional Kits | 63 |
| | Rack Mount Kit N9K-C9300-RMK | 63 |

APPENDIX E **Site Preparation and Maintenance Records** **65**

- Site Preparation Checklist **65**
- Contact and Site Information **66**
- Chassis and Module Information **67**



Preface

- [Audience, on page vii](#)
- [Documentation Conventions, on page vii](#)
- [Related Documentation for Cisco Nexus 9000 Series NX-OS Software, on page viii](#)
- [Documentation Feedback, on page x](#)
- [Obtaining Documentation and Submitting a Service Request, on page x](#)

Audience

This publication is for hardware installers and network administrators who install, configure, and maintain Cisco Nexus switches.

Documentation Conventions

Command descriptions use the following conventions:

| Convention | Description |
|---------------|---|
| bold | Bold text indicates the commands and keywords that you enter literally as shown. |
| <i>Italic</i> | Italic text indicates arguments for which the user supplies the values. |
| [x] | Square brackets enclose an optional element (keyword or argument). |
| [x y] | Square brackets enclosing keywords or arguments separated by a vertical bar indicate an optional choice. |
| {x y} | Braces enclosing keywords or arguments separated by a vertical bar indicate a required choice. |
| [x {y z}] | Nested set of square brackets or braces indicate optional or required choices within optional or required elements. Braces and a vertical bar within square brackets indicate a required choice within an optional element. |
| variable | Indicates a variable for which you supply values, in context where italics cannot be used. |

| Convention | Description |
|------------|---|
| string | A nonquoted set of characters. Do not use quotation marks around the string or the string will include the quotation marks. |

Examples use the following conventions:

| Convention | Description |
|-----------------------------|---|
| screen font | Terminal sessions and information the switch displays are in screen font. |
| boldface screen font | Information you must enter is in boldface screen font. |
| <i>italic screen font</i> | Arguments for which you supply values are in italic screen font. |
| <> | Nonprinting characters, such as passwords, are in angle brackets. |
| [] | Default responses to system prompts are in square brackets. |
| !, # | An exclamation point (!) or a pound sign (#) at the beginning of a line of code indicates a comment line. |

Related Documentation for Cisco Nexus 9000 Series NX-OS Software

The entire Cisco NX-OS 9000 Series documentation set is available at the following URL:

https://www.cisco.com/en/US/products/ps13386/tsd_products_support_series_home.html

Release Notes

The release notes are available at the following URL:

https://www.cisco.com/en/US/products/ps13386/prod_release_notes_list.html

Configuration Guides

These guides are available at the following URL:

https://www.cisco.com/en/US/products/ps13386/products_installation_and_configuration_guides_list.html

The documents in this category include:

- *Cisco Nexus 2000 Series NX-OS Fabric Extender Software Configuration Guide for Cisco Nexus 9000 Series Switches*
- *Cisco Nexus 9000 Series NX-OS Fundamentals Configuration Guide*
- *Cisco Nexus 9000 Series NX-OS High Availability and Redundancy Guide*
- *Cisco Nexus 9000 Series NX-OS Interfaces Configuration Guide*
- *Cisco Nexus 9000 Series NX-OS Layer 2 Switching Configuration Guide*
- *Cisco Nexus 9000 Series NX-OS Multicast Routing Configuration Guide*

- *Cisco Nexus 9000 Series NX-OS Quality of Service Configuration Guide*
- *Cisco Nexus 9000 Series NX-OS Security Configuration Guide*
- *Cisco Nexus 9000 Series NX-OS System Management Configuration Guide*
- *Cisco Nexus 9000 Series NX-OS Unicast Routing Configuration Guide*
- *Cisco Nexus 9000 Series NX-OS Verified Scalability Guide*
- *Cisco Nexus 9000 Series NX-OS VXLAN Configuration Guide*

Other Software Documents

- *Cisco Nexus 7000 Series and 9000 Series NX-OS MIB Quick Reference*
- *Cisco Nexus 9000 Series NX-OS Programmability Guide*
- *Cisco Nexus 9000 Series NX-OS Software Upgrade and Downgrade Guide*
- *Cisco Nexus 9000 Series NX-OS System Messages Reference*
- *Cisco Nexus 9000 Series NX-OS Troubleshooting Guide*
- *Cisco NX-OS Licensing Guide*
- *Cisco NX-OS XML Interface User Guide*

Hardware Documents

- *Cisco Nexus 3000 Series Hardware Installation Guide*
- *Cisco Nexus 92160YC-X NX-OS Mode Switch Hardware Installation Guide*
- *Cisco Nexus 92300YC NX-OS Mode Switch Hardware Installation Guide*
- *Cisco Nexus 92304QC NX-OS Mode Switch Hardware Installation Guide*
- *Cisco Nexus 9236C NX-OS Mode Switch Hardware Installation Guide*
- *Cisco Nexus 9272Q NX-OS Mode Switch Hardware Installation Guide*
- *Cisco Nexus 93108TC-EX NX-OS Mode Switch Hardware Installation Guide*
- *Cisco Nexus 93120TX NX-OS Mode Switch Hardware Installation Guide*
- *Cisco Nexus 93128TX NX-OS Mode Switch Hardware Installation Guide*
- *Cisco Nexus 93180LC-EX NX-OS Mode Switch Hardware Installation Guide*
- *Cisco Nexus 93180YC-EX NX-OS Mode Switch Hardware Installation Guide*
- *Cisco Nexus 9332PQ NX-OS-Mode Switch Hardware Installation Guide*
- *Cisco Nexus 9372PX and 9372PX-E NX-OS Mode Switches Hardware Installation Guide*
- *Cisco Nexus 9372TX and 9372TX-E NX-OS Mode Switches Hardware Installation Guide*
- *Cisco Nexus 9396PX NX-OS Mode Switch Hardware Installation Guide*

- *Cisco Nexus 9396TX NX-OS Mode Switch Hardware Installation Guide*
- *Cisco Nexus 9504 NX-OS Mode Switch Hardware Installation Guide*
- *Cisco Nexus 9508 NX-OS Mode Switch Hardware Installation Guide*
- *Cisco Nexus 9516 NX-OS Mode Switch Hardware Installation Guide*
- *Regulatory, Compliance, and Safety Information for the Cisco Nexus 3000 and 9000 Series*

Documentation Feedback

To provide technical feedback on this document, or to report an error or omission, please send your comments to nexus9k-docfeedback@cisco.com. We appreciate your feedback.

Obtaining Documentation and Submitting a Service Request

For information on obtaining documentation, using the Cisco Bug Search Tool (BST), submitting a service request, and gathering additional information, see *What's New in Cisco Product Documentation*, at: <https://www.cisco.com/warp/public/687/Directory/DirTAC.shtml>.

Subscribe to *What's New in Cisco Product Documentation*, which lists all new and revised Cisco technical documentation as an RSS feed and delivers content directly to your desktop using a reader application. The RSS feeds are a free service.



CHAPTER 1

Overview

- [Overview, on page 1](#)

Overview

The Cisco Nexus 9396PX switch (N9K-C9396PX) is a 2-RU, fixed-port switch designed for Top-of-Rack (ToR), Middle-of-Rack (MoR), and End-of-Rack (EoR) deployment in data centers. This switch has 48 fixed 1- and 10-Gigabit Ethernet downlink ports and a choice of 4-, 6-, or 12-port uplink modules. The chassis for this switch includes the following user-replaceable components:

- Uplink modules (one of either of the following for uplink ports)
 - M4PC-CFP2 uplink module (4-port, 100-Gigabit Ethernet module)
 - M6PQ uplink module (6-port, 40-Gigabit Ethernet module)
 - M6PQ-E uplink module (6-port, 40-Gigabit Ethernet module)
 - M12PQ uplink module (12-port, 10/40-Gigabit Ethernet module)
- Fan modules (three—two for operations and one for redundancy [2+1]) with the following airflow choices:
 - Port-side intake version with burgundy coloring (N9K-C9300-FAN2)
 - Port-side exhaust version with blue coloring (N9K-C9300-FAN2-B)



Note Previously, the Cisco Nexus 9396PX shipped with the N9k-C9300-FAN1-B or N9K-C9300-FAN1 fans. Currently, the N9K-C9300-FAN2-B and N9K-C9300-FAN2 are shipped with the switch.

- Power supplies (two—one for operations and one for redundancy [1+1]) with the following airflow choices:
 - 650-W AC power supply with port-side intake airflow (burgundy coloring) (N9K-PAC-650W)
 - 650-W AC power supply with port-side exhaust airflow (blue coloring) (N9K-PAC-650W-B)

- 1200-W HVAC/HVDC power supply with dual-direction airflow (white coloring) (N9K-PUV-1200W)
- 930-W DC power supply with port-side intake airflow (green coloring) (UCSC-PSU-930WDC)
- 930-W DC power supply with port-side exhaust airflow (gray coloring) (UCS-PSU-6332-DC)



Note Do not mix AC and DC power supplies in the same chassis.



Note All fan modules and power supplies must use the same airflow direction during operations. If you are using the 1200-W HVAC/HVDC power supply, the power supply automatically uses the same airflow direction as used by the other modules in the switch.

The switch supports the Fabric Extenders (FEXs) listed at <https://www.cisco.com/c/en/us/td/docs/switches/datacenter/nexus9000/hw/interoperability/fexmatrix/fextables.html>.

The following figure shows the hardware features seen from the port side of the chassis.

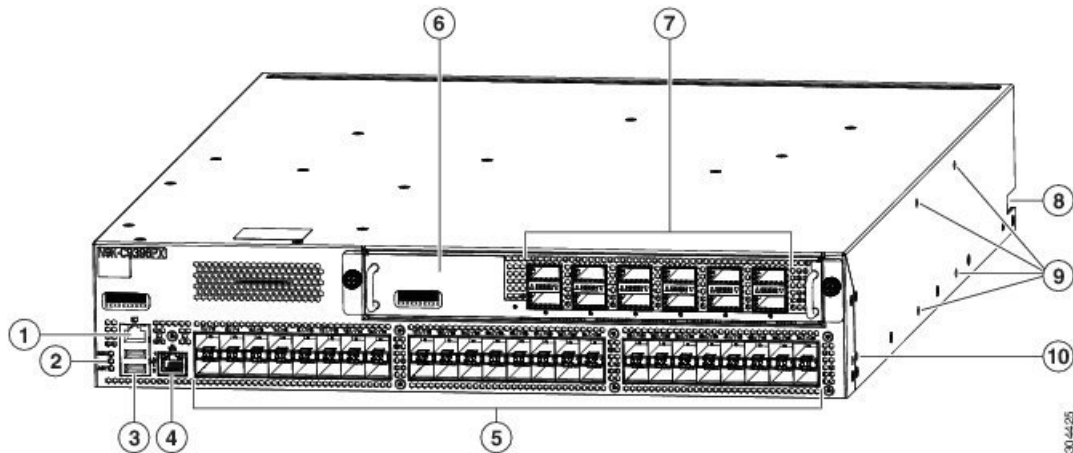

| | | | |
|---|--|---|---|
| 1 | Console port (RS232 port) | 6 | M6PQ, M6PQ-E or M12PQ uplink module (M12PQ uplink module shown). |
| 2 | Chassis LEDs <ul style="list-style-type: none"> • Beacon (BCN) • Status (STS) • Environment (ENV) | 7 | 6- or 12-port 40-Gigabit Ethernet Quad Small Form-Factor Pluggable (QSFP+) optical ports for connections to other devices (12-port uplink module shown) |

| | | | |
|---|--|----|--|
| 3 | Two USB ports used for saving or copying functions Note USB support is limited to USB 2.0 devices that use less than 2.5 W (less than 0.5 A inclusive of surge current). Devices, such as external hard drives, that instantaneously draw more than 0.5 A are not supported. | 8 | Notch in both sides of the chassis for locking the power supply end of the chassis to the bottom-support rails |
| 4 | Out-of-band management port (RJ-45 port) | 9 | Screw holes (4) for attaching a center-mount rack bracket for two-post racks (one bracket for each of two sides) |
| 5 | 48 1- and 10-Gigabit Ethernet Small Form-Factor Pluggable (SFP+) optical ports (supporting 1-Gigabit and 10-Gigabit speeds) to switches or Fabric Extenders (FEXs) | 10 | Screw holes (2) for attaching a front-mount bracket for four-post racks (one bracket on each of two sides) |

To determine which transceivers, adapters, and cables are supported by this switch, see the [Cisco Transceiver Modules Compatibility Information](#) document.

The following figure shows the hardware features seen from the fan side of the chassis.

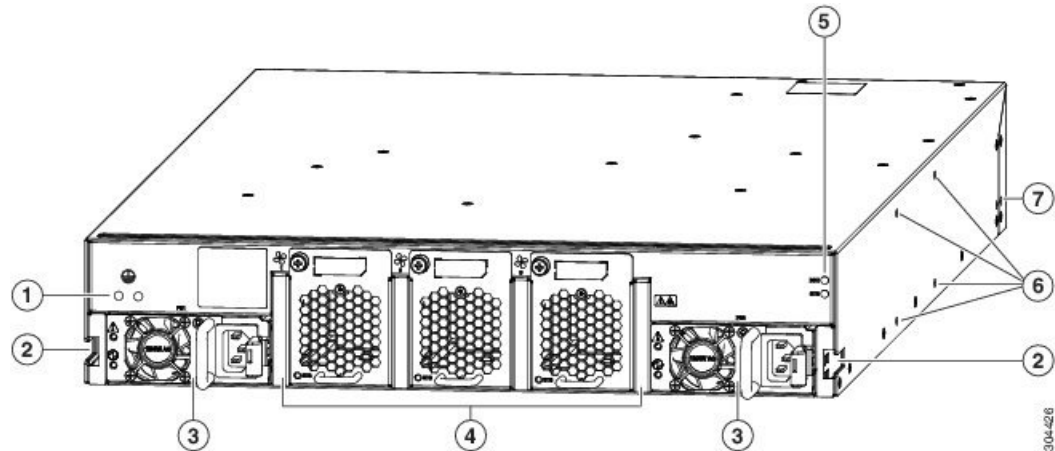

| | | | |
|---|--|---|---|
| 1 | Screw holes (2) for attaching the grounding lug. | 5 | Chassis LEDs are as follows: <ul style="list-style-type: none"> • Beacon (BCN) • Status (STS) |
| 2 | Notch in both sides of the chassis for locking the fan end of the chassis to the bottom-support rails. | 6 | Screw holes (4) for attaching a center-mount rack bracket for two-post racks (one bracket for each of two sides). |

| | | | |
|---|--|---|--|
| 3 | <p>Two power supply modules (AC power supply shown)</p> <p>Power supply slots are numbered 1 on the left and 2 on the right (as seen when looking at the power supplies).</p> | 7 | Screw holes (2) for attaching a front-mount bracket for 4-post racks (1 bracket on each of 2 sides). |
| 4 | <p>Three fan modules (2 used for operations and one used for redundancy) of the following types:</p> <p>Note Earlier shipments of the switch were made with the N9K-C9300-FAN1-B or N9K-C9300-FAN1 fans.</p> <p>Fan slots are numbered 1 (leftmost slot) to 3 (rightmost slot).</p> | | |

You can use the 1- and 10-Gigabit ports to connect this switch to up to 48 devices or to FEXs, which can be connected to additional servers (for the number of FEXs that can be supported, see the release notes for the NX-OS software that you are using). You can connect any of the supported FEXs to the downlink ports.

For installation information on the Cisco Nexus 2000 Series FEXs, see the *Cisco Nexus 2000 Series Hardware Installation Guide*. For information on a B22-HP FEX, see the Getting Started Guide for that FEX model.

Depending on whether you plan to position the ports in a hot or cold aisle, you can order the fan and power supply modules with port-side intake or port-side exhaust airflow. For port-side intake airflow, the fan and AC power supply modules have burgundy coloring (DC power supply modules have green coloring). For port-side exhaust airflow, the fan and AC power supplies have blue coloring (DC power supply modules have gray coloring). You can also order the 1200-W HVAC/HVDC power supply which has dual-direction airflow with white coloring. Dual-direction airflow modules automatically use the airflow direction of the other modules installed in the switch.

The fan and power supply modules are field replaceable and you can replace one fan module or one power supply module during operations so long as the other modules are installed and operating. If you have only one power supply installed, you can install the replacement power supply in the open slot before removing the original power supply.



Note All of the fan and power supply modules must have the same direction of airflow. Otherwise, the switch can overheat and shut down. If you are installing a dual-direction power supply, that module will automatically use the same airflow direction as the other modules in the switch.

**Caution**

If the switch has port-side intake airflow (burgundy coloring for fan modules), you must locate the ports in the cold aisle. If the switch has port-side exhaust airflow (blue coloring for fan modules), you must locate the ports in the hot aisle. If you locate the air intake in a hot aisle, the switch can overheat and shut down.



CHAPTER 2

Preparing the Site

- [Temperature Requirements, on page 7](#)
- [Humidity Requirements, on page 7](#)
- [Altitude Requirements, on page 7](#)
- [Dust and Particulate Requirements, on page 8](#)
- [Minimizing Electromagnetic and Radio Frequency Interference, on page 8](#)
- [Shock and Vibration Requirements, on page 9](#)
- [Grounding Requirements, on page 9](#)
- [Planning for Power Requirements, on page 9](#)
- [Airflow Requirements, on page 10](#)
- [Rack and Cabinet Requirements, on page 11](#)
- [Clearance Requirements, on page 12](#)

Temperature Requirements

The switch requires an operating temperature of 32 to 104 degrees Fahrenheit (0 to 40 degrees Celsius). If the switch is not operating, the temperature must be between –40 to 158 degrees Fahrenheit (–40 to 70 degrees Celsius).

Humidity Requirements

High humidity can cause moisture to enter the switch. Moisture can cause corrosion of internal components and degradation of properties such as electrical resistance, thermal conductivity, physical strength, and size. The switch is rated to withstand from 5- to 95-percent (noncondensing) relative humidity.

Buildings in which the climate is controlled by air-conditioning in the warmer months and by heat during the colder months usually maintain an acceptable level of humidity for the switch equipment. However, if the switch is located in an unusually humid location, use a dehumidifier to maintain the humidity within an acceptable range.

Altitude Requirements

This switch is rated to operate at altitudes from 0 to 13,123 feet (0 to 4,000 meters). If you operate this switch at a higher altitude (low pressure), the efficiency of forced and convection cooling is reduced and can result

in electrical problems that are related to arcing and corona effects. This condition can also cause sealed components with internal pressure, such as electrolytic capacitors, to fail or to perform at a reduced efficiency.

Dust and Particulate Requirements

Exhaust fans cool power supplies and system fans cool switches by drawing in air and exhausting air out through various openings in the chassis. However, fans also ingest dust and other particles, causing contaminant buildup in the switch and increased internal chassis temperature. Dust and particles can act as insulators and interfere with the mechanical components in the switch. A clean operating environment can greatly reduce the negative effects of dust and other particles.

In addition to regular cleaning, follow these precautions to avoid contamination of your switch:

- Do not permit smoking near the switch.
- Do not permit food or drink near the switch.

Minimizing Electromagnetic and Radio Frequency Interference

Electromagnetic interference (EMI) and radio frequency interference (RFI) from the switch can adversely affect other devices, such as radio and television (TV) receivers. Radio frequencies that emanate from the switch can also interfere with cordless and low-power telephones. Conversely, RFI from high-power telephones can cause spurious characters to appear on the switch monitor.

RFI is defined as any EMI with a frequency above 10 kHz. This type of interference can travel from the switch to other devices through the power cable and power source or through the air as transmitted radio waves. The Federal Communications Commission (FCC) publishes specific regulations to limit the amount of EMI and RFI that are emitted by computing equipment. Each switch meets these FCC regulations.

To reduce the possibility of EMI and RFI, follow these guidelines:

- Cover all open expansion slots with a blank filler plate.
- Always use shielded cables with metal connector shells for attaching peripherals to the switch.

When wires are run for any significant distance in an electromagnetic field, interference can occur to the signals on the wires with the following implications:

- Bad wiring can result in radio interference emanating from the plant wiring.
- Strong EMI, especially when it is caused by lightning or radio transmitters, can destroy the signal drivers and receivers in the chassis and even create an electrical hazard by conducting power surges through lines into equipment.



Note

To predict and prevent strong EMI, you need to consult experts in radio frequency interference (RFI).

The wiring is unlikely to emit radio interference if you use a twisted-pair cable with a good distribution of grounding conductors. If you exceed the recommended distances, use a high-quality twisted-pair cable with one ground conductor for each data signal when applicable.

**Caution**

If the wires exceed the recommended distances, or if wires pass between buildings, give special consideration to the effect of a lightning strike in your vicinity. The electromagnetic pulse that is caused by lightning or other high-energy phenomena can easily couple enough energy into unshielded conductors to destroy electronic switches. You will want to consult experts in electrical surge suppression and shielding if you had similar problems in the past.

Shock and Vibration Requirements

The switch has been shock- and vibration-tested for operating ranges, handling, and earthquake standards.

Grounding Requirements

The switch is sensitive to variations in voltage that is supplied by the power sources. Overvoltage, undervoltage, and transients (or spikes) can erase data from memory or cause components to fail. To protect against these types of problems, ensure that there is an earth-ground connection for the switch. You can connect the grounding pad on the switch either directly to the earth-ground connection or to a fully bonded and grounded rack.

When you properly install the chassis in a grounded rack, the switch is grounded because it has a metal-to-metal connection to the rack. Alternatively, you can ground the chassis by using a customer-supplied grounding cable that meets your local and national installation requirements. For U.S. installations, we recommend 6-AWG wire. Connect your grounding cable to the chassis with a grounding lug (provided in the switch accessory kit) and to the facility ground.

**Note**

You automatically ground AC power supplies when you connect them to AC power sources. For DC power supplies, you must connect a grounding wire when wiring the power supply to the DC power source.

Planning for Power Requirements

The switch includes two power supplies (1-to-1 redundancy with current sharing) in one of the following combinations:

- Two 650-W AC power supplies
- Two 1200-W HVAC/HVDC power supplies
- Two 930-W DC power supplies

**Note**

Both power supplies must be the same type. Do not mix AC, DC, and HVAC/HVDC power supplies in the same chassis.



Note For $n+1$ redundancy, you can use one or two power sources for the two power supplies. For $n+n$ redundancy, you must use two power sources and connect each power supply to a separate power source.

The power supplies are rated to output up to 650 W (AC power supplies), up to 1200 W (HVAC/HVDC power supplies), or up to 930 W (DC power supplies), but the switch requires less than those amounts of power from the power supply. To operate the switch, you must provision enough power from the power source to cover the requirements of both the switch and a power supply. Typically, this switch and a power supply require about 232 W of power input from the power source, but you must provision as much as 455 W power input from the power source to cover peak demand.



Note Some of the power supply modules have rating capabilities that exceed the switch requirements. When calculating your power requirements, use the switch requirements to determine the amount of power that is required for the power supplies.

To minimize the possibility of circuit failure, make sure that each power-source circuit that is used by the switch is dedicated to the switch.



Note For AC input application, please refer to the following statement:



Warning **Statement 1005**—Circuit Breaker

This product relies on the building's installation for short-circuit (overcurrent) protection. Ensure that the protective devices are rated not greater than 20A (North America), 16A (Europe), and 13A (UK).



Note For DC input application, please refer to the following statement:



Note We recommend 8-AWG wire for DC installations in the U.S.



Note For the power cables to use with the power supplies, see [Power Cable Specifications, on page 54](#).

Airflow Requirements

The switch is positioned with its ports in either the front or the rear of the rack depending on your cabling and maintenance requirements. You must have fan and power supply modules that move the coolant air from the cold aisle to the hot aisle in one of the following ways:

- Port-side exhaust airflow—Cool air enters the chassis through the fan and power supply modules in the cold aisle and exhausts through the port end of the chassis in the hot aisle.
- Port-side intake airflow—Cool air enters the chassis through the port end in the cold aisle and exhausts through the fan and power supply modules in the hot aisle.
- Dual-direction airflow—The direction of the installed fan modules determines the airflow.

You can identify the airflow direction of each fan and power supply module by its coloring as follows:

- Blue coloring indicates port-side exhaust airflow.
- Burgundy coloring indicates port-side intake airflow.
- White coloring on HVAC/HVDC power supplies indicates dual-direction airflow.
- Gray coloring on DC power supplies indicates port-side exhaust airflow.
- Green coloring on DC power supplies indicates port-side intake airflow.



Note To prevent the switch from overheating and shutting down, you must position the air intake for the switch in a cold aisle. The fan and power supply modules must have the same direction of airflow (even if their coloring is different). If you must change the airflow direction for the switch, you must shutdown the switch before changing the modules.

Rack and Cabinet Requirements

You can install the following types of racks or cabinets for your switch:

- Standard perforated cabinets
- Solid-walled cabinets with a roof fan tray (bottom-to-top cooling)
- Standard open four-post Telco racks
- Standard open two-post Telco racks

Work with your cabinet vendors to determine which of their cabinets meet the following requirements or see the Cisco Technical Assistance Center (TAC) for recommendations:

- Use a standard 19-inch (48.3-cm), four-post Electronic Industries Alliance (EIA) cabinet or rack with mounting rails that conform to English universal hole spacing per section 1 of the ANSI/EIA-310-D-1992 standard.
- The depth of a four-post rack must be 24 to 32 inches (61.0 to 81.3 cm) between the front and rear mounting rails (for proper mounting of the bottom-support brackets or other mounting hardware).
- Required clearances between the chassis and the edges of its rack or the interior of its cabinet are as follows:
 - 4.5 inches (11.4 cm) between the front of the chassis and the interior of the cabinet (required for cabling).

- 3.0 inches (7.6 cm) between the rear of the chassis and the interior of the cabinet (required for airflow in the cabinet if used).
- No clearance is required between the chassis and the sides of the rack or cabinet (no side airflow).

Also, you must have power receptacles that are located within reach of the power cords that are used with the switch.



Warning Statement 1048—Rack Stabilization

The rack stabilizing mechanism must be in place, or the rack must be bolted to the floor before installation or servicing. Failure to stabilize the rack can cause bodily injury.

Clearance Requirements

Provide the chassis with adequate clearance between the chassis and any other rack, device, or structure so that you can properly install the chassis. Provide the chassis with adequate clearance to route cables, provide airflow, and maintain the switch. For the clearances required for an installation of this chassis in a four-post rack, see the following figure.

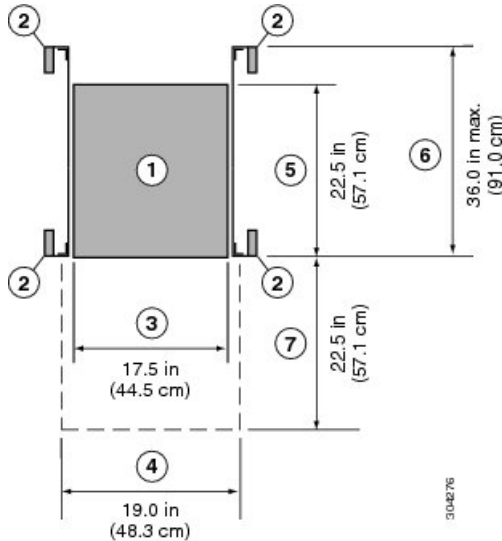

| | | | |
|---|---|---|--|
| 1 | Chassis | 5 | Depth of the chassis |
| 2 | Vertical rack-mount posts and rails | 6 | Maximum extension of the bottom-support rails |
| 3 | Chassis width | 7 | Depth of the front clearance area (equal to the depth of the chassis). |
| 4 | Width of the front clearance area (equal to the width of the chassis with two rack-mount brackets that are attached to it). | | |

For the clearances required for a two-post rack installation, see the following figure.

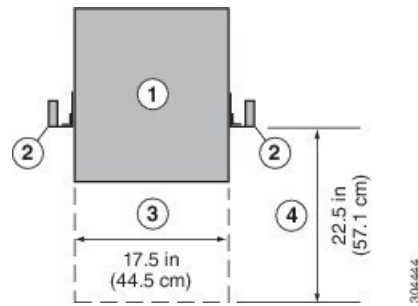

| | | | |
|---|-------------------------------------|---|--|
| 1 | Chassis | 3 | Chassis width |
| 2 | Vertical rack-mount posts and rails | 4 | Service clearance that is required for replacing the chassis (equals the length of the chassis). |



Note Both the front and rear of the chassis must be open to both aisles for airflow.



CHAPTER 3

Installing the Chassis

- [Installation Options with Rack-Mount Kits, Racks, and Cabinets, on page 15](#)
- [Install a Rack, on page 16](#)
- [Unpacking and Inspecting a New Switch, on page 16](#)
- [Planning How to Position the Chassis in the Rack, on page 18](#)
- [Installing the Chassis in a Two-Post Rack, on page 18](#)
- [Installing the Chassis in a Four-Post Rack, on page 21](#)
- [Grounding the Chassis, on page 27](#)
- [Powering Up the Switch, on page 28](#)

Installation Options with Rack-Mount Kits, Racks, and Cabinets

The rack-mount kit enables you to install the switch into racks of varying depths. You can position the switch with easy access to either the port connections or the fan and power supply modules.

You can install the switch using the following rack-mount options:

- Rack-mount kit (N9K-C9300-RMK) which you can order from Cisco.

You can install the switch in the following types of racks:

- Open EIA rack
- Perforated EIA cabinet

The rack or cabinet that you use must meet the requirements listed in [General Requirements for Cabinets and Racks, on page 47](#) section.



Note You are responsible for verifying that your rack and rack-mount hardware comply with the guidelines that are described in this doc.

Install a Rack

Before you install the switch, you must install a standard two- or four-post, 19-inch EIA data center rack (or a cabinet that contains such a rack) that meets the requirements listed in [Overview of Racks, on page 47](#).

Step 1 Bolt the rack to the concrete subfloor before moving the chassis onto it.

Warning Statement 1048—Rack Stabilization

The rack stabilizing mechanism must be in place, or the rack must be bolted to the floor before installation or servicing. Failure to stabilize the rack can cause bodily injury.

Step 2 If the rack has bonded construction, connect it to the earth ground. This action enables you to easily ground the switch and its components and to ground your electrostatic discharge (ESD) wrist strap to prevent damaging discharges when you handle ungrounded components before installing them.

Step 3 Include one or two power sources at the rack. For AC power, provide a power receptacle. For DC power, provide a circuit breaker with terminals for connecting power cables.

Warning Statement 1018—Supply Circuit

To reduce risk of electric shock and fire, take care when connecting units to the supply circuit so that wiring is not overloaded.

Note If you are not using power redundancy or are using $n+1$ redundancy, you need only one power source. If you are using $n+n$ redundancy, you need two power sources.

Unpacking and Inspecting a New Switch

Before you install a new chassis, you need to unpack and inspect it to be sure that you have all the items that you ordered and verify that the switch was not damaged during shipment. If anything is damaged or missing, contact your customer representative immediately.



Caution

When you handle the chassis or its components, you must follow ESD protocol at all times to prevent ESD damage. This protocol includes but is not limited to wearing an ESD wrist strap that you connect to the earth ground.



Tip

Do not discard the shipping container when you unpack the switch. Flatten the shipping cartons and store them. If you need to move or ship the system in the future, you will need this container.

Step 1 Compare the shipment to the equipment list that is provided by your customer service representative and verify that you have received all of the ordered items.

The shipment should include the following:

- Switch chassis, which includes the following installed components:
 - One uplink module:
 - M4PC uplink module
 - M6PQ uplink module
 - M6PQ-E uplink module
 - M12PQ uplink module
 - Two power supplies (any combination of the following with the airflow direction being the same as for the fan modules):
 - 650-W AC power supply
 - Port-side exhaust airflow with blue coloring (N9K-PAC-650W-B)
 - Port-side intake airflow with burgundy coloring (N9K-PAC-650W)
 - 1200-W HVAC/HVDC power supply
 - Dual-direction HVAC/HVDC power supply with white coloring (N9K-PUV-1200W)
 - 930-W DC power supply
 - Port-side exhaust airflow with gray coloring (UCS-PSU-6332-DC)
 - Port-side intake airflow with green coloring (UCSC-PDU-930WDC)
 - Three fan modules (all fan and power supply modules must have the same airflow direction)
 - Port-side exhaust airflow with blue coloring (N9K-C9300-FAN2-B)
 - Port-side intake airflow with burgundy coloring (N9K-C9300-FAN2)
 - Port-side exhaust airflow with blue coloring (N9K-C9300-FAN1-B) (previously shipped with the switch)
 - Port-side intake airflow with burgundy coloring (N9K-C9300-FAN1) (previously shipped with the switch)
- Switch accessory kit
- Rack mount kit

Step 2 Check the contents of the box for damage.

Step 3 If you notice any discrepancies or damage, send the following information to your customer service representative by email:

- Invoice number of the shipper (see the packing slip)
- Model and serial number of the missing or damaged unit

- Description of the problem and how it affects the installation
-

Planning How to Position the Chassis in the Rack

The switch is designed so that you can have coolant air flow through the switch in one of the two following directions:

- Enter the port side and exhaust out the power supply side (port-side intake airflow)
- Enter the power supply side and exhaust out the port side (port-side exhaust airflow)

For port-side intake airflow, the switch must have port-side intake fan and AC power supply modules with one or more of the following colorings:

- Burgundy coloring on fan modules and AC power supplies
- Green coloring on DC power supplies
- White coloring on 1200-W HVAC/HVDC power supplies (dual-direction airflow power supplies with their airflow direction set by the fan modules)

For port-side exhaust airflow, the switch must have port-side exhaust fan and AC power supply modules with one or more of the following colorings:

- Blue coloring on fan modules and AC power supplies
- Gray coloring on DC power supplies
- White coloring on 1200-W HVAC/HVDC power supplies (dual-direction airflow power supplies with their airflow direction set by the fan modules)

You can plan the positioning of the switch so that its ports are located close to ports on connected devices or so that the fan and power supply modules are conveniently located in a maintenance aisle, and then order the modules that move coolant air in the appropriate direction from the cold aisle to the hot aisle.



Note All fan and power supply modules in the same switch must operate with the same direction of airflow and the air intake portion of the switch must be located in a cold aisle.

Installing the Chassis in a Two-Post Rack

Before you install the chassis, be sure that the rack is fully secured to the data center floor.

You must attach mounting brackets to the chassis before mounting the chassis.

Attaching Center-Mount Brackets to the Chassis

You need to attach a right-angled bracket to each side of the chassis. This bracket centers the chassis and secures it in place on a two-post rack.



Warning Statement 1006—Chassis Warning for Rack-Mounting and Servicing

To prevent bodily injury when mounting or servicing this unit in a rack, you must take special precautions to ensure that the system remains stable. The following guidelines are provided to ensure your safety:

- This unit should be mounted at the bottom of the rack if it is the only unit in the rack.
- When mounting this unit in a partially filled rack, load the rack from the bottom to the top with the heaviest component at the bottom of the rack.
- If the rack is provided with stabilizing devices, install the stabilizers before mounting or servicing the unit in the rack.

Before you begin

- You must separately order the center-mount brackets if you are installing the chassis in a two-post rack. These brackets do not ship with the chassis unless you specifically order them.
- You must have the following tools and equipment:
 - Manual Phillips-head torque screwdriver
 - Center-mount bracket kit

Step 1

Align one of the two center-mount brackets on the left or right side of the chassis and be sure that the angled portion is facing the front of the chassis (see the following figure).

Be sure to align four of the screw holes on the larger side of the bracket with the four screw holes near the center of the left or right side of the chassis.

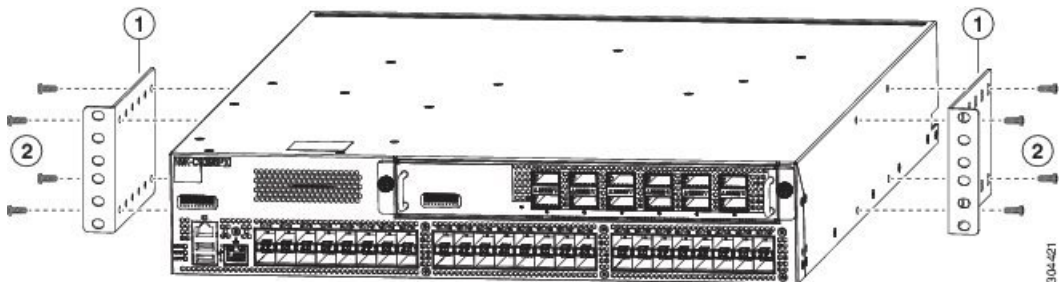

| | | | |
|---|---|---|--|
| 1 | Center-mount bracket with its larger side facing the chassis and the longer side facing the front (port side) of the chassis. Align four screw holes in the bracket to four screw holes in the side of the chassis. | 2 | Four M4 x 8 mm screws used to fasten the bracket to the chassis. |
|---|---|---|--|

Step 2

Use four M4 x 8 mm screws to attach the bracket to the chassis. Tighten each screw to 11 to 15 in-lb (1.2 to 1.7 N·m).

Step 3 Repeat Steps 1 and 2 to attach the second center-mount bracket to the other side of the chassis.

What to do next

You are ready to mount the chassis to the two-post rack.

Installing the Chassis in a Two-Post Rack

You need to position the chassis near the top of the rack with the power supply and fan modules in the appropriate aisle for their required airflow. If the fan modules have a blue coloring for port-side exhaust airflow, then you must position the modules by the cold aisle. If the fan modules have a burgundy coloring for port-side intake airflow, you must position the modules by the hot aisle.



Note Power supply modules must have the same airflow direction as the fan modules.



Note Power supply modules must have the same airflow direction as the fan modules but might have different coloring if they use DC power (green coloring for port-side intake airflow or gray coloring for port-side exhaust airflow). HVAC/HVDC power supplies with white coloring use the same direction of airflow as used by the fan modules.



Warning **Statement 1074**—Comply with Local and National Electrical Codes

To reduce risk of electric shock or fire, installation of the equipment must comply with local and national electrical codes.



Warning **Statement 1032**—Lifting the Chassis

To prevent personal injury or damage to the chassis, never attempt to lift or tilt the chassis using the handles on modules (such as power supplies, fans, or cards); these types of handles are not designed to support the weight of the unit.

Before you begin

- Make sure that the two-post rack is properly installed and secured to the concrete subfloor.
- Make sure that two center-mount brackets are securely fastened to the middle of each side of the chassis.
- Make sure that you have six customer-supplied rack-mount screws (typically M6 x 10 mm or the appropriate screw for the vertical mounting rails on the rack).
- You have at least two people to install the chassis.



Warning Statement 1006—Chassis Warning for Rack-Mounting and Servicing

To prevent bodily injury when mounting or servicing this unit in a rack, you must take special precautions to ensure that the system remains stable. The following guidelines are provided to ensure your safety:

- This unit should be mounted at the bottom of the rack if it is the only unit in the rack.
- When mounting this unit in a partially filled rack, load the rack from the bottom to the top with the heaviest component at the bottom of the rack.
- If the rack is provided with stabilizing devices, install the stabilizers before mounting or servicing the unit in the rack.

Step 1

Use one person to position the chassis so that it is near the top of the rack with the fan and power supply modules in the appropriate aisle and the center-mount bracket has its screw holes aligned to screw holes on the two-post rack.

If these modules have a blue or gray coloring for port-side exhaust airflow, then you must position the modules by the cold aisle. If the modules have a burgundy or green coloring for port-side intake airflow, you must position the modules by the hot aisle.

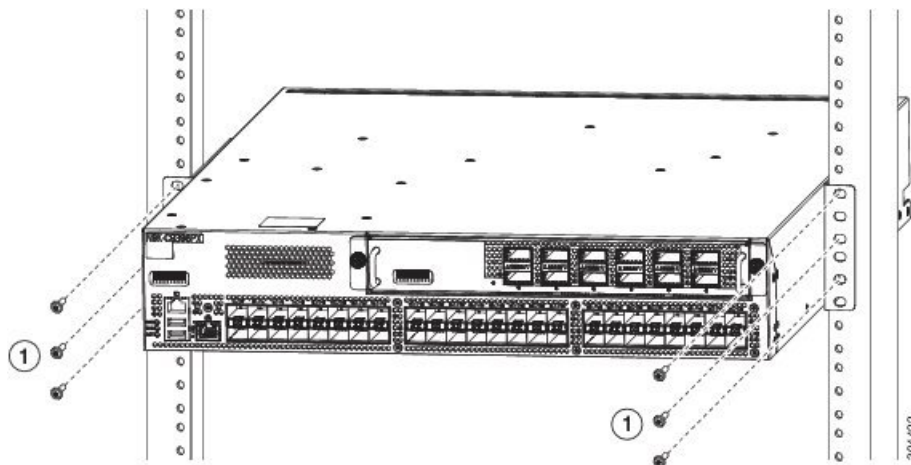

| | | |
|---|--|--|
| 1 | Three customer-supplied screws (typically M6 x 10 mm screws or the appropriate screws for the rack) to hold each side of the chassis to the two-post rack. | |
|---|--|--|

Step 2

Use the second person to secure the three customer-supplied rack-mount screws (typically M6 x 10 mm or other appropriate screws for the rack) on each center-mount bracket to attach the chassis to the rack. Tighten each screw to the appropriate torque setting for the screws (for M6 x 10 mm screws, use 40 in-lbs [4.5 N·m] of torque).

Installing the Chassis in a Four-Post Rack

Before you install the chassis, be sure that the rack is fully secured to the data center floor.

Installing the Switch using the N9K-C9300-RMK Rack-mount Kit

Attaching the Bottom-Support Rails to the Rack

The switch chassis that you are installing ships with two adjustable bottom-support rails that you can attach to a four-post rack to hold the chassis. Each of these bottom-support rails has two pieces—one that slides into the other so that you can adjust them to fit racks with front and rear mounting posts that are spaced less than 36 inches (91 cm). On each bottom-support rail, the rail half that slides into the other rail includes a chassis stop that fits into the module end of the chassis. Depending on direction of the chassis airflow, you need to position the rail half with the chassis stop so that the fan and power supply modules end up in the appropriate aisle as follows:

- Port-side intake (burgundy coloring for fan modules) airflow requires that the bottom-support rail with the chassis stop be located on the hot aisle side of the rack.
- Port-side exhaust (blue coloring for fan modules) airflow requires that the bottom-support rail with the chassis stop be located on the cold aisle side of the rack.



Warning **Statement 1074**—Comply with Local and National Electrical Codes

To reduce risk of electric shock or fire, installation of the equipment must comply with local and national electrical codes.

Before you begin

Before you can install the bottom support rails for the chassis, you must do the following:

- Verify that a four-post rack or cabinet is installed.
- If any other devices are stored in the rack or cabinet, verify that the heavier switches are installed below lighter switches.
- Verify that the bottom-support rails kit is included in the switch accessory kit.
- Verify that you have 8 screws for attaching the bottom support brackets to the racks (typically M6 x 10 mm screws or the screw appropriate for the vertical mounting rails on the rack).



Warning **Statement 1006**—Chassis Warning for Rack-Mounting and Servicing

To prevent bodily injury when mounting or servicing this unit in a rack, you must take special precautions to ensure that the system remains stable. The following guidelines are provided to ensure your safety:

- This unit should be mounted at the bottom of the rack if it is the only unit in the rack.
 - When mounting this unit in a partially filled rack, load the rack from the bottom to the top with the heaviest component at the bottom of the rack.
 - If the rack is provided with stabilizing devices, install the stabilizers before mounting or servicing the unit in the rack.
-

- Step 1** Look at the fan and power supply modules installed in the chassis to determine how you must position the bottom-support rails on the rack.
- If the fan modules have blue coloring (port-side exhaust modules), you must position the bottom support rails so that the chassis stop is positioned by the cold aisle.
 - If the fan modules have burgundy (port-side intake modules), you must position the bottom support rails so that the chassis stop is positioned by the hot aisle.
- Step 2** Separate the two sliders that make up one bottom-support rail and position the half with the chassis stop by the appropriate aisle for the fan and power supply modules. Also make sure that there is at least 1 rack unit open above the bottom-support rails so that you can easily install the chassis.
- Step 3** Use two customer-supplied screws (typically M6 x 10 mm screws) to attach the bottom-support rail half to the vertical mounting rails on the rack post. Tighten each screw to the appropriate torque setting for the screws (for M6 x 10 mm screws, use 40 in. lbs [4.5 N·m] of torque).
- Step 4** Slide the other half of the bottom-support rail onto the attached half of the rail set and use two customer supplied screws (typically M6 x 10 mm screws) to secure that portion to the vertical mounting rails on the rack. Tighten each screw to the appropriate torque setting for the screws (for M6 x 10 mm screws, use 40 in. lbs [4.5 N·m] of torque).

Figure 1: Positioning an Expanding Bottom-Support Rail Set

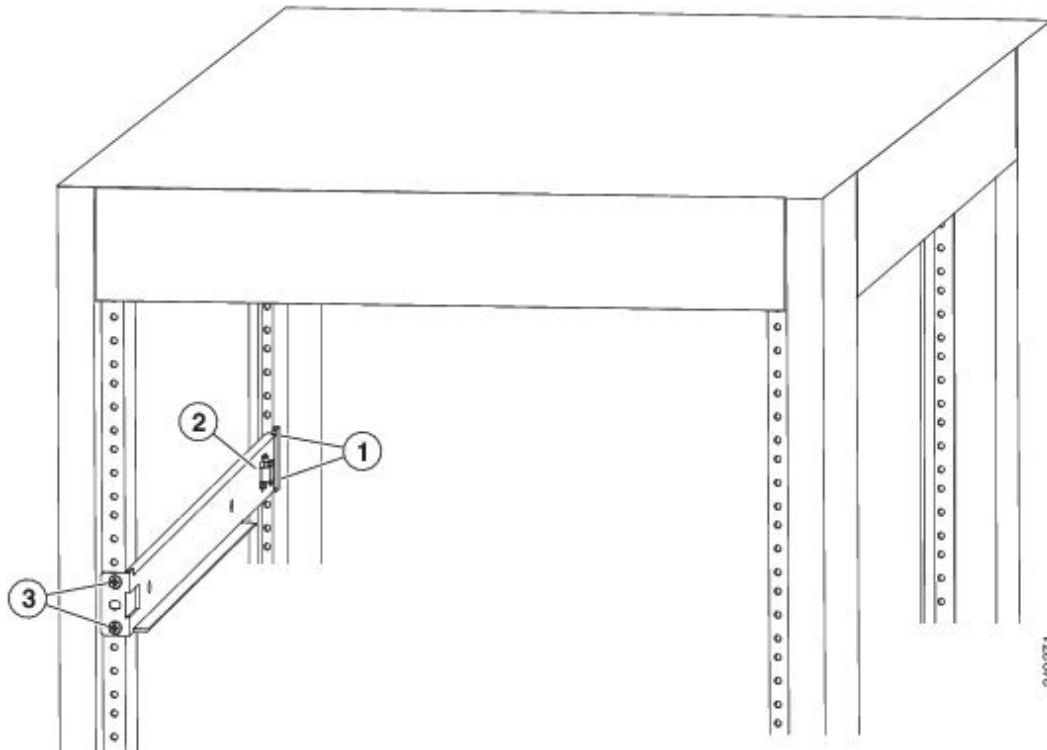

| | | | |
|---|--|---|--|
| 1 | 2 screws holding one end of the bottom-support bracket to the rear of the rack | 3 | 2 screws holding the front end of the bottom-support bracket to the front side of the rack |
|---|--|---|--|

| | | | |
|---|--|--|--|
| 2 | Chassis stop on the expanding bottom-support bracket | | |
|---|--|--|--|

Step 5 Repeat Steps 2 and 3 to attach the other expanding bottom-support rails to the other side of the rack.

Note Check the two installed bottom support rails to be sure that both have their chassis stops by the same aisle (either both by the hot aisle or both by the cold aisle) and that both rails are level and level with each other. If they are not level, adjust the higher rail down to the level of the lower rail.

What to do next

You are ready to install two front-mount brackets on the chassis.

Attaching Front-Mount Brackets to the Chassis

You need to attach a right-angled bracket to each side of the chassis. This bracket holds the chassis in place on a four-post rack.

Before you begin

- You must have the following tools and equipment:
 - Manual Phillips-head torque screwdriver
 - Front-mount brackets (2) and screws (4) (found inside the switch accessory kit)

Step 1 Align the two holes in one side of one of two front-mount brackets to two holes on the left or right side of the chassis (see the following figure).

Be sure that the other side of the bracket is facing toward the front (port end) of the chassis.

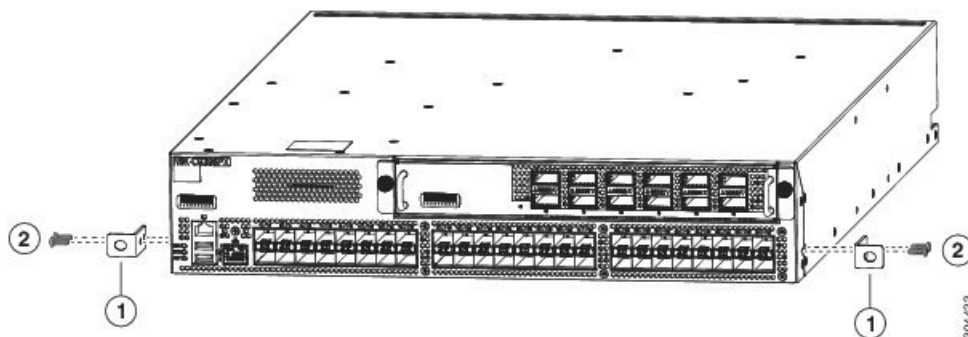

| | | | |
|---|--|---|---|
| 1 | Front-mount bracket with two screw holes aligned to two screw holes in the chassis and one screw hole facing the front (port side) of the chassis. | 2 | Two M4 x 6 mm screws used to fasten the bracket to the chassis. |
|---|--|---|---|

Step 2 Use two M4 x 6 mm screws to attach the bracket to the chassis. Tighten each screw to 11 to 15 in-lb (1.2 to 1.7 N·m).

Step 3 Repeat Steps 1 and 2 to attach the second center-mount bracket to the other side of the chassis.

What to do next

You are ready to mount the chassis to the four-post rack.

Installing the Chassis in a Four-Post Rack

You need to slide the chassis onto the bottom-support rails so that the power supply end locks onto the chassis stops at the end of the rails and so that the front-mount brackets on the chassis come into contact with the front-mount rails on the rack.



Warning **Statement 1074**—Comply with Local and National Electrical Codes

To reduce risk of electric shock or fire, installation of the equipment must comply with local and national electrical codes.



Warning **Statement 1032**—Lifting the Chassis

To prevent personal injury or damage to the chassis, never attempt to lift or tilt the chassis using the handles on modules (such as power supplies, fans, or cards); these types of handles are not designed to support the weight of the unit.

Before you begin

- Make sure that the four-post rack is properly installed and secured to the concrete subfloor.
- Make sure that the bottom-support rails are installed so that the fan modules will be in the appropriate aisle as follows:
 - Burgundy (port-side intake airflow) fan modules are positioned in a hot aisle (the chassis stop on the bottom-support rails is positioned by the hot aisle).
 - Blue colored (port-side exhaust airflow) fan modules are positioned in a cold aisle (the chassis stop on the bottom-support rails is positioned by the cold aisle).
- Make sure that two front-mount brackets are securely fastened to the sides of the chassis at the port end.
- Make sure that you have two customer-supplied rack-mount screws (M6 x 10 mm or appropriate screw for the vertical mounting rails on the rack).



Warning Statement 1006—Chassis Warning for Rack-Mounting and Servicing

To prevent bodily injury when mounting or servicing this unit in a rack, you must take special precautions to ensure that the system remains stable. The following guidelines are provided to ensure your safety:

- This unit should be mounted at the bottom of the rack if it is the only unit in the rack.
- When mounting this unit in a partially filled rack, load the rack from the bottom to the top with the heaviest component at the bottom of the rack.
- If the rack is provided with stabilizing devices, install the stabilizers before mounting or servicing the unit in the rack.

Step 1 Slide the power supply end of the chassis onto the bottom-support rails that are installed on the rack.

Be sure that the sides of the chassis by the power supplies clips into the chassis stops on the bottom-support rails and the front-mount brackets come in contact with the rack (see the following figure).

Note If the bottom-support rails are extended a long distance, they can bend outwards slightly when you install the chassis and the chassis stops at the far end of the rails might not fit into the end of the chassis. If this happens, press the side rails toward the sides of the chassis so that the chassis stops can go inside the chassis and hold it in place on the rack.

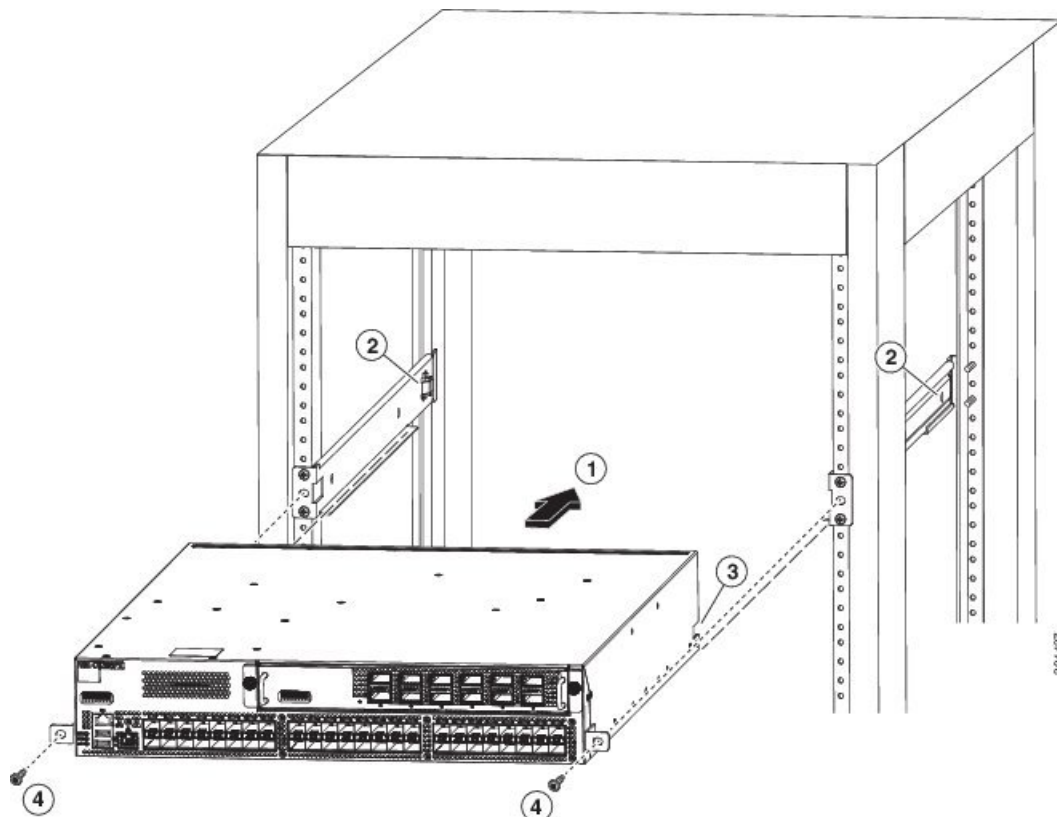

| | | | |
|---|---|---|--|
| 1 | Slide the power-supply end of the chassis onto the bottom-support rails so that the chassis locks onto the chassis stops at the end of the rails. | 3 | Receiving hole on each side of the chassis for the chassis stops on the bottom-support rails. |
| 2 | Chassis stops for holding the chassis (positioned by the aisle required for the fan and power supply modules). | 4 | Customer-supplied rack-mount screw (M6 x 10 mm screw or other screw appropriate for the rack) used to secure each side of the chassis to the rack. |

- Step 2** Use a customer-supplied rack-mount screw (an M6 x 10 mm screw or other appropriate screw for the rack) to attach each of the two mounting brackets on the chassis to the rack and tighten each screw to the appropriate torque setting for the screw (for M6 x 10 mm screws, use 40 in-lbs [4.5 N·m] of torque).

Grounding the Chassis

The switch chassis is automatically grounded when you properly install the switch in a grounded rack with metal-to-metal connections between the switch and rack.

You can also ground the chassis, which is required if the rack is not grounded, by attaching a customer-supplied grounding cable. Attach the cable to the chassis grounding pad and the facility ground.



Warning Statement 1024—Ground Conductor

This equipment must be grounded. To reduce the risk of electric shock, never defeat the ground conductor or operate the equipment in the absence of a suitably installed ground conductor. Contact the appropriate electrical inspection authority or an electrician if you are uncertain that suitable grounding is available.



Warning Statement 1046—Installing or Replacing the Unit

To reduce risk of electric shock, when installing or replacing the unit, the ground connection must always be made first and disconnected last.

Before you begin

Before you can ground the chassis, you must have a connection to the earth ground for the data center building.

- Step 1** Use a wire-stripping tool to remove approximately 0.75 inch (19 mm) of the covering from the end of the grounding wire. We recommend 6-AWG wire for the U.S. installations.
- Step 2** Insert the stripped end of the grounding wire into the open end of the grounding lug. Use a crimping tool to crimp the lug to the wire, see the following figure. Verify that the ground wire is securely attached to the grounding lug by attempting to pull the wire out of the crimped lug.

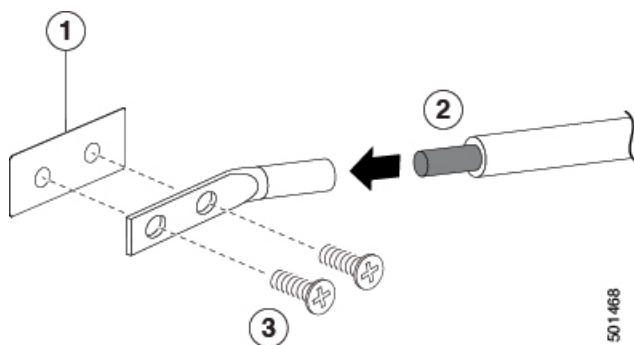

| | | | |
|---|---|---|---|
| 1 | Chassis grounding pad | 3 | 2 M4 screws are used to secure the grounding lug to the chassis |
| 2 | Grounding cable, with 0.75 in. (19 mm) of insulation that is stripped from one end, which is inserted into the grounding lug and crimped in place | | |

Step 3 Secure the grounding lug to the chassis grounding pad with two M4 screws, see the previous figure. Tighten the screws to 11 to 15 in-lb (1.24 to 1.69 N·m) of torque.

Step 4 Prepare the other end of the grounding wire and connect it to the facility ground.

Powering Up the Switch

To power up the switch, you must connect the power supplies to one or two power sources. The number of power sources used depends on the type of power redundancy that you require as follows:

- For no power redundancy, connect only the power supplies to one power source.
- For $n+1$ redundancy, connect the power supplies to one or two power sources.
- For $n+n$ redundancy, connect each power supply to a different power source (two power sources required).

Statement 7012—Equipment Interfacing with AC Power Ports

This equipment shall be connected to AC mains provided with a surge protective device (SPD) at the service equipment complying with NFPA 70, the National Electrical Code (NEC).



Warning Statement 1004—Installation Instructions

Read the installation instructions before using, installing or connecting the system to the power source.

**Warning Statement 1018**—Supply Circuit

To reduce risk of electric shock and fire, take care when connecting units to the supply circuit so that wiring is not overloaded.

Before you begin

- Switch installed in a rack and connected to an earth ground
- Recommended power cable for your nation or region
- Power source with the required amperage located within reach of the power cable being used

Connect each power supply to a power source as follows:

- Connecting an AC power supply:
 1. Using the recommended power cable for your country or region (see [Power Cable Specifications, on page 54](#)), connect the C13 plug on the power cable to the power receptacle on the power supply.
 2. Rotate the cable retention clip on the power supply over the C13 plug to prevent accidental unplugging of the cable.
 3. Connect the other end of the power cable to the AC power source.
 4. Verify that the  LED is on and green.
If the LED is off, check the AC power source circuit breaker to be sure that it is turned on.
- Connecting a DC power supply:
 1. Verify that the circuit breaker for the DC power source you are connecting is turned off.
 2. Remove the DC power connector block from the power supply by doing the following:
 1. Push the orange plastic button on the top of the connector block inward toward the power supply.
 2. Pull the connector block out of the power supply.
 3. Strip 0.6 inches (15 mm) of insulation off the DC wires that you are using.
 4. Orient the connector as shown in the following figure with the orange plastic button on top.

Figure 2: Wiring a 930W -48VDC Power Supply Connector Block



| | | | |
|---|---|---|-------------------------------------|
| 1 | Wire retainer lever | 4 | -48V (-DC) cable |
| 2 | Orange plastic button on top of the connector | 5 | Grounding cable (8 AWG recommended) |
| 3 | -48V Return (+DC) cable | | |

5. Use a small screwdriver to depress the spring-loaded wire retainer lever on the lower spring-cage wire connector. Insert your green (ground) wire into the aperture and then release the lever.
6. Use a small screwdriver to depress the spring-loaded wire retainer lever on the middle spring-cage wire connector. Insert your black (DC negative) wire into the aperture and then release the lever.
7. Use a small screwdriver to depress the spring-loaded wire retainer lever on the upper spring-cage wire connector. Insert your red (DC positive) wire into the aperture and then release the lever.
8. Insert the connector block back into the power supply. Make sure that your red (DC positive) wire aligns with the power supply label, "+ DC".

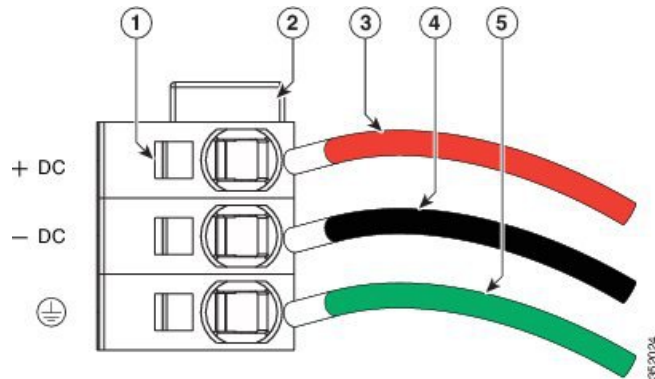
Note If you require $n+n$ redundancy, be sure that each power supply is powered by a different power source.

• Connecting an HVAC/HVDC power supply:

1. Using the recommended power cable for your country or region (see [Power Cable Specifications, on page 54](#)), insert the Saf-D-Grid connector on the power cable to the power receptacle on the power supply until it clicks in place.
2. Connect the other end of the power cable to the power source.
 - If connecting to an AC power source, plug the cable into the receptacle for the power source.
 - If connecting to a DC power source, do the following:
 1. Verify that the power source is turned off at the circuit breaker located between the power source and the terminals where you will connect the power cable.
 2. Connect each of the three wires in the power cable to the three terminals for the power source and secure them with the terminal nuts. Make sure that the positive wire is attached to the positive terminal, the negative wire is attached to the negative terminal, and the ground wire is attached to the ground terminal.

3. If there is a safety cover for the terminals, place it over the terminals to prevent people from accidentally touching the terminals when the power is on.
 4. Turn the power on at the circuit breaker.
-
3. Verify that the  LED is on and green.
If the LED is off, check the AC power source circuit breaker to be sure that it is turned on.
-



CHAPTER 4

Connecting the Switch to the Network

- [Setting Up the Management Interface, on page 33](#)
- [Uplink Connections, on page 33](#)
- [Downlink Connections, on page 34](#)
- [Guidelines for Connecting Ports, on page 34](#)
- [Maintaining Transceivers and Optical Cables, on page 35](#)

Setting Up the Management Interface

The management port (MGMT ETH) provides out-of-band management, which enables you to use the command-line interface (CLI) to manage the switch by its IP address. This port uses a 10/100/1000 Ethernet connection with an RJ-45 interface.

Before you begin

The switch must be powered on.

-
- Step 1** Connect the RJ-45, UTP cable to the MGMT ETH port on the switch.
- Step 2** Connect the other end of the cable to a 10/100/1000 Ethernet port on a network device.
-

What to do next

You are ready to connect the interface ports on each of the line cards to the network.

Uplink Connections

The switch has an uplink module with 12 or six 40-Gigabit optical ports or four 100-Gigabit optical ports. For a list of transceivers and cables used by this switch for uplink connections, see <http://www.cisco.com/c/en/us/support/interfaces-modules/transceiver-modules/products-device-support-tables-list.html>.

By default, the 40-Gigabit uplink ports operate at 40 Gbps, but you can use the **speed-group 10000** command to change the administrative speed to 10 Gbps. If you change the speed, you must also use a QSFP-to-SFP adapter and a supported SFP+ transceiver in each of the converted SFP+ ports. All of the ports in a group of

ports must operate at the same speed or you will see an error with a "check speed-group config" message. The 12-port uplink module has two port groups (ports 1 through 6 [2/1-6], and ports 7 through 12 [2/7-12], the six-port uplink module has six active ports (ports 1 through 6), and the four-port uplink module has four active ports (ports 1 through 4). To return the administrative speed to 40 Gigabits, use the **no speed-group 10000** command.



Note The M12PQ uplink module ports connected with copper cables do not autonegotiate their speeds so you must set the speed for each port at the connected device by using the **speed 40000** command.



Warning **Statement 1051**—Laser Radiation

Invisible laser radiation may be emitted from disconnected fibers or connectors. Do not stare into beams or view directly with optical instruments.

Downlink Connections

The Cisco Nexus 9396PX switch has 48 downlink ports that connect to servers or Fabric Extenders (FEXs). Each of these ports supports 1-Gigabit and 10-Gigabit speeds over optical cables.

For a listing of the transceivers and cables that the optical downlink ports support, see <http://www.cisco.com/c/en/us/support/interfaces-modules/transceiver-modules/products-device-support-tables-list.html>

Guidelines for Connecting Ports

You can use Quad Small Form-Factor Pluggable Plus (QSFP+) transceivers for uplink connections to other network devices. You can use SFP or SFP+ transceivers for downlink connections to other network devices.

For information about the transceivers currently being used with the switch, use the **show inventory all** command.

Prevent damage to the fiber-optic cables that can separate from their cables. Keep the transceivers disconnected from their fiber-optic cables when installing the transceiver in the line card. Before removing such a transceiver from the switch, remove the cable from the transceiver.

To maximize the effectiveness and life of your transceivers and optical cables, do the following:

- Wear an ESD-preventative wrist strap that is connected to an earth ground whenever handling transceivers. The switch is typically grounded during installation and provides an ESD port to which you can connect your wrist strap.
- Do not remove and insert a transceiver more often than is necessary. Repeated removals and insertions can shorten its useful life.
- Keep the transceivers and fiber-optic cables clean and dust free to maintain high signal accuracy and to prevent damage to the connectors. Contamination causes increased attenuation (loss of light), and should be kept below 0.35 dB.
 - Clean these parts before installation to prevent dust from scratching the fiber-optic cable ends.

- Clean the connectors regularly; the required frequency of cleaning depends upon the environment. In addition, clean connectors if they are exposed to dust or accidentally touched. Both wet and dry cleaning techniques can be effective; refer to your site's fiber-optic connection cleaning procedures.
- Do not touch the ends of connectors. Touching the ends can leave fingerprints and cause other contamination.
- Inspect routinely for dust and damage. If you suspect damage, clean and then inspect fiber ends under a microscope to determine if damage has occurred.
- To minimize the chance of damaging transceivers when installing them, slide them gently into their switch slots. Never force transceivers all the way into the slots. If the transceiver stops part way into the slot, it might be upside down. Remove the transceiver before turning it over and reinstalling it. If positioned correctly, the transceiver slides all the way into the slot and clicks when fully installed.



Warning Statement 1051—Laser Radiation

Invisible laser radiation may be emitted from disconnected fibers or connectors. Do not stare into beams or view directly with optical instruments.



Warning Statement 1055—Class I and Class 1M Laser

Class 1/1M laser product.



Warning Statement 1056—Unterminated Fiber Cable

Invisible laser radiation may be emitted from the end of the unterminated fiber cable or connector. Do not view directly with optical instruments. Viewing the laser output with certain optical instruments (for example, eye loupes, magnifiers, and microscopes) within a distance of 100 mm may pose an eye hazard.

Maintaining Transceivers and Optical Cables

Transceivers and fiber-optic cables must be kept clean and dust free to maintain high signal accuracy and prevent damage to the connectors. Contamination increases attenuation (loss of light) and should be below 0.35 dB.

Consider the following maintenance guidelines:

- Transceivers are static sensitive. To prevent ESD damage, wear an ESD-preventative wrist strap that is connected to the grounded chassis.
- Do not remove and insert a transceiver more often than is necessary. Repeated removals and insertions can shorten its useful life.
- Keep all optical connections covered when not in use. Clean them before using to prevent dust from scratching the fiber-optic cable ends.

- Do not touch the ends of connectors. Touching the ends can leave fingerprints and cause other contamination.
- Clean the connectors regularly; the required frequency of cleaning depends upon the environment. In addition, clean connectors if they are exposed to dust or accidentally touched. Both wet and dry cleaning techniques can be effective; refer to the fiber-optic connection cleaning procedures for your site.
- Inspect routinely for dust and damage. If you suspect damage, clean and then inspect fiber ends under a microscope to determine if damage has occurred.



CHAPTER 5

Replacing Modules

- [Replacing the Uplink Module, on page 37](#)
- [Replacing a Fan Module During Operations, on page 38](#)
- [Replacing a Power Supply Module, on page 40](#)

Replacing the Uplink Module

You must shut down the switch before replacing the M4PC-CFP2, M6PQ, M6PQ-E, or M12PQ uplink module.



Note The M12PQ, M6PQ, and M6PQ-E uplink-module ports connected with copper cables do not auto negotiate their speeds so you must set the speed for each port at the connected device by using the **speed 40000** command.

- Step 1** Power off the switch by removing the power cables from both of the power supplies installed in the switch.
- Step 2** Verify that both LEDs on each power supply are off and that all of the other switch LEDs are off. If any LEDs are on, look for a power supply that is still powered on and remove its power cable.
- Step 3** Remove the cables from each of the ports on the uplink module. Be sure to label each cable for future reference.
- Step 4** Unscrew both captive screws on the front of the module.
- Step 5** Holding both handles on the front of the module, slide the module out of the slot.
- Caution** To prevent electrostatic discharge (ESD) damage to the module electronics, do not touch the electrical connectors on the back side of the module. Also, to prevent any damage to the electrical connectors, prevent them touching anything that can bend or break them.
- Step 6** Place the module on an antistatic surface or inside an antistatic bag. If possible, repack the module in its shipping materials for safe shipping or storage.
- Step 7** Remove the replacement module from its packing materials and place it on an antistatic surface.
- Hold the module by its two handles and do not touch the electrical connectors on its backside. Also, to protect the electrical connectors, avoid letting them come in contact with anything other than the electrical connectors inside the chassis.

- Step 8** Holding the replacement module by its two handles, position the module with the electrical components on its backside facing the open uplink-module slot.
- Step 9** Slide the module all the way into the chassis until its front side comes in contact with the chassis. For the last 0.2 inches (0.5 cm), carefully mount the module onto the chassis connectors by pushing more firmly, but do not force the module if it does not move further (excessive force can damage the connectors).
- Note** If you are not able to push the module all the way into the slot, carefully slide the module out of the slot and check its electrical connectors for damage. If damaged, contact Cisco Technical Assistance for help. If undamaged, repeat Step 6 to reinstall the module.
- Step 10** Screw in both captive screws on the front of the module to secure the module to the chassis. Tighten each screw to 8 in-lb (0.9 N·m).
- Step 11** Verify that the Status (STS) LED turns on and becomes amber.
- Step 12** Reconnect each of the uplink cables and verify that the LED for each port becomes green.
- Under each set of two uplink ports, there is an Active (ACT) LED that indicates whether the ports are active for this switch. Connect cables to only the active ports.
-

Replacing a Fan Module During Operations

There must always be at least one fan module installed in the chassis to maintain the designed airflow. You can remove one fan module temporarily to replace it with another fan module within two minutes to avoid a shutdown, but if the replacement fan module is not available, leave the original fan module in the chassis.

All fan and power supply modules must have the same airflow direction or else an error can occur with the switch overheating and shutting down. You can determine the airflow direction of a fan module by the color of the stripe on the front of the module. If the fan module has a blue stripe for port-side exhaust airflow, the power supplies must have blue or gray coloring for the same airflow direction. If the fan module has a burgundy stripe for port-side intake airflow, the power supplies must have burgundy or green coloring for the same airflow direction. If a power supply has white coloring, it can be used with fan modules using either port-side intake or port-side exhaust airflow. To avoid over heating the switch, make sure that the fan modules are positioned in one of the following ways:

- For port-side exhaust airflow with blue coloring, position the fan modules in a cold aisle.
- For port-side intake airflow with burgundy coloring, position the ports in a cold aisle.

Before you begin

Before you can replace a fan module, ensure that both of the following conditions exist:

- There are two functioning fan modules in the other fan slots. In order to replace a fan module during operations, there must be two fan modules circulating air in the chassis at all times. The other fan module is redundant and can be replaced.
- The replacement fan module must have the same airflow direction as the other modules in the chassis.

If you must replace the fan module during operations and both of the above conditions are not met, leave the fan module that you need to replace in the chassis to preserve the designed airflow until you have the required module.

Step 1 Remove the fan module that you need to replace as follows:

- a) Verify that the fan modules that you are not replacing each have a lit Status (STS) LED (see the following figure for the location of the LED). If you are replacing a fan module during operations, the other two fan modules must be operating.

Note If you are replacing the fan module while the chassis is not operating, you can skip this step.

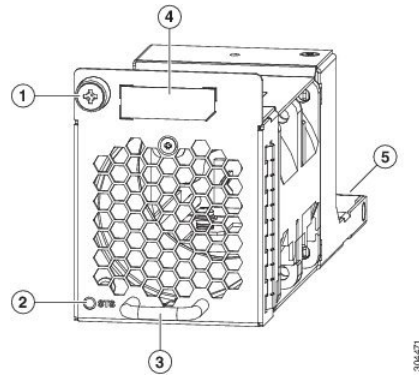

| | | | |
|---|------------------|---|---|
| 1 | Captive screw | 4 | Colored stripe specifying the airflow direction (burgundy for the port-side intake direction or blue for the port-side exhaust direction) |
| 2 | Status (STS) LED | 5 | Electrical connectors on the backside. |
| 3 | Handle | | |

Note Early shipments of the switch included the FAN1 or FAN1-B fan modules, which have a slightly different appearance when removed from the chassis.

- b) Pull the fan module handle to slide the module out of the chassis.

Caution To prevent electrostatic discharge (ESD) damage to the module electronics, do not touch the electrical connectors on the back side of the module. Also, to prevent any damage to the electrical connectors, prevent them touching anything that can bend or break them.

- c) Place the removed module on an antistatic surface or in an antistatic bag. If possible, repack the module in its packing materials for safe shipping or storage.

Step 2 Follow these steps to replace the missing fan module within two minutes to avoid a shutdown.

- a) Remove the replacement fan module from its packing materials and place it on an antistatic surface.

Hold the module by its handle and do not touch the electrical connectors on its backside. Also, to protect the electrical connectors, avoid letting them come in contact with anything other than the electrical connectors inside the chassis.

- b) Verify that you have the right fan module for the chassis. The correct fan module has one of the following part numbers:

- N9K-C9300-FAN2-B (port-side exhaust airflow direction and a blue stripe)
- N9K-C9300-FAN2 (port-side intake airflow direction and a burgundy stripe)

Note Previously, the Cisco Nexus 9396PX shipped with the N9k-C9300-FAN1-B or N9K-C9300-FAN1 fans. Currently, the N9K-C9300-FAN2-B and N9K-C9300-FAN2 are shipped with the switch by default.

Note Be sure that the airflow direction of the new fan module matches the airflow direction of the other fan and AC power supply modules already installed in the chassis. Port-side intake airflow is indicated with burgundy or green coloring, and port-side exhaust airflow is indicated with blue or gray coloring. Power supplies with dual-direction airflow (airflow direction is set by the fan modules) have white coloring.

- c) Position the fan module in front of the open fan slot (be sure that the backside of the module with the electrical connectors is positioned to enter the slot first) and slide the module all the way into the chassis until its front side comes in contact with the chassis. For the last 0.2 inches (0.5 cm), carefully mount the module onto the chassis connectors by pushing more firmly, but do not force the module if it does not move further (excessive force can damage the connectors).

Note If you are not able to push the module all the way into the slot, carefully slide the module out of the slot and check its electrical connectors for damage. If damaged, contact Cisco Technical Assistance for help. If undamaged, repeat this step to reinstall the module.

- d) Verify that the STS LED turns on and becomes green.

If the STS LED does not turn on, slide the module out of the chassis, and visually check the electrical connectors on the back side of the chassis for damage. If damaged, contact Cisco Technical Assistance for help. If undamaged, repeat the previous step to reinstall the module.

- e) Secure the fan module to the chassis by screwing in the captive screw to the chassis. Tighten the screw to 5 to 7 in-lb (0.56 to 0.79 N·m).

Replacing a Power Supply Module

The switch requires two power supplies for redundancy. With one power supply providing the necessary power for operations, you can replace the other power supply during operations so long as the new power supply has the same airflow direction as the other modules in the chassis.

You can replace a power supply with another supported power supply that has the same power source type and the same wattage rating as the other installed power supply. Additionally, the airflow direction of the power supply must match or conform to the airflow direction of the installed fan modules. For the airflow direction used by the switch, see the coloring of the fan modules.



Removing an AC Power Supply

To remove an AC power supply, you must first disconnect the power cable and then remove the module from the chassis.

Before you begin

- To replace a power supply during operations, you must have a functioning power supply providing power to the switch while you replace the other power supply. If there is only one power supply installed in the switch and you need to replace it, install the new power supply in the open slot and power it up before removing the original power supply.

- Ensure that the chassis is grounded. For grounding instructions, see [Grounding the Chassis, on page 27](#).

-
- Step 1** Pull the power cord out from the power receptacle on the power supply to be removed and verify that the  LED turns off.
- Note** The  LED might be on and amber colored to indicate that the input power has been disconnected.
- Note** If you need to remove an Anderson's Saf-D-Grid power cable connector from a high-voltage power supply, press the tab at the top of the connector and pull the connector out of the power supply.
- Step 2** Remove the power supply from the chassis by pushing and holding its thumb latch to the left and pulling the power supply part way out of the chassis.
- Step 3** Place your other hand under the power supply to support it while you slide it out of the chassis.
Either place the power supply on an antistatic surface or pack it in its packing materials.
- Step 4** If the power supply slot is to remain empty, install a blank power supply filler panel (part number N2200-P-BLNK).
-

What to do next

You are ready to install the replacement power supply.

Removing an HVAC/HVDC Power Supply

You can remove one power supply while the other one provides power to the switch.

To disconnect the power supply from its power cables, you must shut off the power from the power source and then either disconnect a connector for the power cables or release each of three cables from the power supply (requires a standard screw driver).

-
- Step 1** Turn off the circuit breaker for the power feed to the power supply that you are replacing.
Be sure that the LEDs turn off on the power supply that you are removing.
- Step 2** Remove the power cable from the power supply by pressing the tab on the top of the Anderson Power SAF-D-Grid connector and pull the cable and connector out of the power supply.
- Step 3** Grasp the power supply handle while pressing the release latch towards the power supply handle.
- Step 4** Place your other hand under the power supply to support it while you slide it out of the chassis.
- Caution** Do not touch the electrical connectors on the back side of the module and prevent anything else from coming into contact with and damaging the connectors.
-

What to do next

You are ready to install an HVAC/HVDC power supply in the open slot.

Removing a DC Power Supply

You can remove one power supply while the other one provides power to the switch.

To disconnect the power supply from its power cables, you must shut off the power from the power source and then either disconnect a connector for the power cables or release each of three cables from the power supply (requires a standard screw driver).

-
- Step 1** Turn off the circuit breaker for the power feed to the power supply that you are replacing.
Be sure that the LEDs turn off on the power supply that you are removing.
- Step 2** Remove the power cable from the power supply by doing the following:
- To remove an orange power cable connector from a 48-V DC power supply, do the following:
 1. Push the orange plastic button on the top of the connector block inward toward the power supply.
 2. Pull the connector block out of the power supply.
 - To remove an Anderson Power Products Saf-D-Grid power cable connector from a high-voltage power supply, press on the tab at the top of the Saf-D-Grid connector and pull the connector out of the power supply.
- Step 3** Grasp the power supply handle while pressing the release latch towards the power supply handle.
- Step 4** Pull the power supply out of the bay.
-

What to do next

You are ready to install a DC power supply in the open slot.

Installing an AC Power Supply

You can replace one power supply while the other one provides power to the switch.

Before you begin

- The power supply that you are installing must be capable of using the same airflow direction as the fan trays installed in the same switch and it must use the same type of power source as the other power supply installed in the same switch (do not mix AC and DC power supplies in the same switch).



Note DC power supplies with green coloring have the same port-side intake airflow direction as the power supplies with red coloring, and DC power supplies with gray coloring have the same port-side exhaust airflow direction as the power supplies with blue coloring. HVAC/HVDC power supplies automatically use the same airflow direction as the installed fan modules. If the power supply that you are replacing has a different color handle than the replacement power supply, verify that it has or will have the same airflow direction as the other modules in the switch.

- An AC power source must be within reach of the power cable that will be used with the replacement power supply. If you are using $n+n$ power redundancy, there must be a separate power source for each power supply installed in the chassis. Otherwise, only one power source is required.
- There must be an earth ground connection to the chassis that you are installing the replacement module. Typically, the chassis is grounded by its metal-to-metal connection with a grounded rack. If you need to ground the chassis, see [Grounding the Chassis, on page 27](#).

Step 1 Holding the replacement power supply with one hand underneath the module and the other hand holding the handle, turn the power supply so that its release latch is on the right side and align the back end of the power supply (the end with the electrical connections) to the open power supply slot before carefully sliding the power supply all the way into the slot until it clicks into place.

Note If the power supply does not fit into the open slot, turn the module over before sliding it carefully into the open slot.

Step 2 Test the installation by trying to pull the power supply out of the slot without using the release latch.

If the power supply does not move out of place, it is secured in the slot. If the power supply moves, carefully press it all the way into the slot until it clicks in place.

Step 3 Attach the power cable to the electrical outlet on the front of the power supply.

Step 4 Make sure that the other end of the power cable is attached to the appropriate power source for the power supply.

Note Depending on the outlet receptacle on your power distribution unit, you might need the optional jumper cable to connect the switch to your outlet receptacle.

Step 5 Verify that the power supply is operational by making sure that the power supply  LED is green. For information on what the power supply LEDs indicate, see [Power Supply LEDs, on page 61](#).

Installing an HVAC/HVDC Power Supply

You can replace one power supply while the other one provides power to the switch.



Note DC power supplies with green coloring have the same port-side intake airflow direction as the power supplies with red coloring, and DC power supplies with gray coloring have the same port-side exhaust airflow direction as the power supplies with blue coloring. HVAC/HVDC power supplies automatically use the same airflow direction as the installed fan modules. If the power supply that you are replacing has a different color handle than the replacement power supply, verify that it has or will have the same airflow direction as the other modules in the switch.

Before you begin

- If you are using DC power for the replacement power supply, the circuit breaker for the power feed to the power supply that you are replacing must be turned off.

- If you are using $n+n$ power redundancy, there must be a separate power source for each power supply installed in the chassis (power sources must be of the same type—do not mix AC and DC power sources for the same switch). Otherwise, only one power source is required.
- There must be an earth ground connection to the chassis that you are installing the replacement module. Typically, the chassis is grounded by its metal-to-metal connection to a grounded rack. If you need to ground this chassis by another means, see [Grounding the Chassis, on page 27](#).

-
- Step 1** Holding the replacement power supply with one hand underneath the module and the other hand holding the handle, turn the power supply so that its release latch is on the right side and align the back end of the power supply (the end with the electrical connections) to the open power supply slot before carefully sliding the power supply all the way into the slot until it clicks into place.
- Note** If the power supply does not fit into the open slot, turn the module over before sliding it into the open slot.
- Step 2** Test the installation by trying to pull the power supply out of the slot without using the release latch. If the power supply does not move out of place, it is secured in the slot. If the power supply moves, carefully press it all the way into the slot until it clicks in place.
- Step 3** If the DC power cables and a grounding cable are already connected to an electrical connector block, insert the block into the power receptacle on the power supply. If the electrical cables have not been connected to the electrical connector block, wire them as described in [Wiring a 48 V DC Electrical Connector Block, on page 45](#).
- Step 4** Make sure that the other end of the power cable is connected to the appropriate power source for the power supply.
- Step 5** If using a DC power source, turn on the circuit breaker for the DC power source connected to the power supply.
- Step 6** Verify that the power supply is operational by making sure that the power supply  LED is green. For information on what the power supply LEDs indicate, see [Power Supply LEDs, on page 61](#).
-

Installing a DC Power Supply

This topic is for installing the 48-V DC power supply into switch chassis. If you need to install a high voltage (HVAC/HVDC) power supply, see [Installing an HVAC/HVDC Power Supply, on page 43](#).

You can replace one power supply while the other one provides power to the switch.

Before you begin

- The circuit breaker for the DC power source for the power supply must be turned off.
- The power supply that you are installing must be capable of using the same airflow direction as the fan trays installed in the same switch
- A DC power source must be within reach of the power cable that will be used with the replacement power supply. If you are using $n+n$ power redundancy, there must be a separate power source for each power supply installed in the chassis (do not mix AC and DC power sources for the same switch). Otherwise, only one power source is required.

- There must be an earth ground connection to the chassis that you are installing the replacement module. Typically, the chassis is grounded by its metal-to-metal connection to a grounded rack. If you need to ground this chassis by another means, see [Grounding the Chassis, on page 27](#).

Step 1 Holding the replacement power supply with one hand underneath the module and the other hand holding the handle, turn the power supply so that its release latch is on the right side and align the back end of the power supply (the end with the electrical connections) to the open power supply slot before carefully sliding the power supply all the way into the slot until it clicks into place.

Note If the power supply does not fit into the open slot, turn the module over before carefully sliding it into the open slot.

Step 2 If the DC power cables and a grounding cable are already connected to an electrical connector block, insert the block into the power receptacle on the power supply.

If the electrical cables have not been connected to the electrical connector block, wire them as described in [Wiring a 48 V DC Electrical Connector Block, on page 45](#).

Step 3 Turn on the circuit breaker for the DC power source connected to the power supply.

Step 4 Verify that the power supply is operational by making sure that the power supply  LED is green. For information on what the power supply LEDs indicate, see [Power Supply LEDs, on page 61](#).

Wiring a 48 V DC Electrical Connector Block

You must connect the ground, negative, and positive DC power cables to a connector block in order to connect the power cables to a 48 V DC power supply.



Note The recommended wire gauge is 8 AWG. The minimum wire gauge is 10 AWG.



Warning **Statement 342**—Before Connecting to System Power Supply

High touch/leakage current – Permanently connected protective earth ground is essential before connecting to system power supply.



Warning **Statement 1024**—Ground Conductor

This equipment must be grounded. To reduce the risk of electric shock, never defeat the ground conductor or operate the equipment in the absence of a suitably installed ground conductor. Contact the appropriate electrical inspection authority or an electrician if you are uncertain that suitable grounding is available.

Before you begin

You must turn off the circuit breaker for the DC power cables that you are connecting to prevent electrocution.

Step 1 Verify that the circuit breaker for the power feed to the replacement power supply is turned off.

Step 2 Remove the DC power connector block from the power supply by doing the following:

- a) Push the orange plastic button on the top of the connector block inward toward the power supply.
- b) Pull the connector block out of the power supply.

Step 3 Strip 0.6 inches (15 mm) of insulation off the DC wires that you are using.

Step 4 Orient the connector as shown in the following figure with the orange plastic button on top.

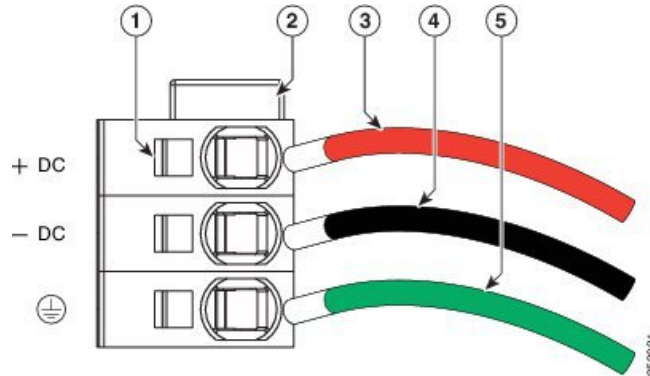

| | | | |
|---|---|---|-------------------------------------|
| 1 | Wire retainer lever | 4 | -48V (-DC) cable |
| 2 | Orange plastic button on top of the connector | 5 | Grounding cable (8 AWG recommended) |
| 3 | -48V Return (+DC) cable | | |

Step 5 Use a small screwdriver to depress the spring-loaded wire retainer lever on the lower spring-cage wire connector. Insert your green (ground) wire into the aperture and then release the lever.

Step 6 Use a small screwdriver to depress the spring-loaded wire retainer lever on the middle spring-cage wire connector. Insert your black (DC negative) wire into the aperture and then release the lever.

Step 7 Use a small screwdriver to depress the spring-loaded wire retainer lever on the upper spring-cage wire connector. Insert your red (DC positive) wire into the aperture and then release the lever.

Step 8 Insert the connector block back into the power supply. Make sure that your red (DC positive) wire aligns with the power supply label, "+ DC".

Step 9 Verify that the other ends of the cables are attached to the DC power source and ground. You are then ready to turn on the DC power source.



APPENDIX **A**

Rack Specifications

- [Overview of Racks, on page 47](#)
- [General Requirements for Cabinets and Racks, on page 47](#)
- [Requirements Specific to Standard Open Racks, on page 48](#)
- [Requirements Specific to Perforated Cabinets, on page 48](#)
- [Cable Management Guidelines, on page 48](#)

Overview of Racks

You can install the switch in the following types of cabinets and racks, assuming an external ambient air temperature range of 0 to 104°F (0 to 40°C):

- Standard perforated cabinets
- Solid-walled cabinets with a roof fan tray (bottom to top cooling)
- Standard open racks



Note If you are selecting an enclosed cabinet, we recommend one of the thermally validated types, either standard perforated or solid-walled with a fan tray.



Note We do not recommend that you use racks that have obstructions (such as power strips), because the obstructions could impair access to field-replaceable units (FRUs).

General Requirements for Cabinets and Racks

The cabinet or rack must also meet the following requirements:

- Standard 19-inch (48.3 cm) (two- or four-post EIA cabinet or rack, with mounting rails that conform to English universal hole spacing per section 1 of ANSI/EIA-310-D-1992). For more information, see [Requirements Specific to Perforated Cabinets, on page 48](#).

- The minimum vertical rack space requirement per chassis is:
 - For a one RU (rack unit) switch, 1.75 inches (4.4 cm)
 - For a one and a half RU (rack unit) switch, 2.63 (6.68 cm)
 - For a two RU (rack unit) switch, 3.5 inches (8.8 cm)
 - For a three RU (rack unit) switch, 5.25 inches (13.3 cm)
- The width between the rack-mounting rails must be at least 17.75 inches (45.0 cm) if the rear of the device is not attached to the rack. For four-post EIA racks, this measurement is the distance between the two front rails.

Four-post EIA cabinets (perforated or solid-walled) must meet the following requirements:

- The minimum spacing for the bend radius for fiber-optic cables should have the front-mounting rails of the cabinet offset from the front door by a minimum of 3 inches (7.6 cm).
- The distance between the outside face of the front mounting rail and the outside face of the back mounting rail should be 23.0 to 30.0 inches (58.4 to 76.2 cm) to allow for rear-bracket installation.

Requirements Specific to Standard Open Racks

If you are mounting the chassis in an open rack (no side panels or doors), ensure that the rack meets the following requirements:

- The minimum vertical rack space per chassis must be two rack units (RUs), equal to 3.5 inches (8.8 cm).
- The distance between the chassis air vents and any walls should be 2.5 inches (6.4 cm).

Requirements Specific to Perforated Cabinets

A perforated cabinet has perforations in its front and rear doors and side walls. Perforated cabinets must meet the following requirements:

- The front and rear doors must have at least a 60 percent open area perforation pattern, with at least 15 square inches (96.8 square cm) of open area per rack unit of door height.
- The roof should be perforated with at least a 20 percent open area.
- The cabinet floor should be open or perforated to enhance cooling.

The Cisco R Series rack conforms to these requirements.

Cable Management Guidelines

To help with cable management, you might want to allow additional space in the rack above and below the chassis to make it easier to route all of the fiber optic or copper cables through the rack.



APPENDIX **B**

System Specifications

- [Environmental Specifications, on page 49](#)
- [Switch Dimensions, on page 49](#)
- [Switch and Module Weights and Quantities, on page 50](#)
- [Transceiver and Cable Specifications, on page 51](#)
- [Switch Power Input Requirements, on page 51](#)
- [Power Specifications, on page 51](#)
- [Power Cable Specifications, on page 54](#)
- [Regulatory Standards Compliance Specifications, on page 56](#)

Environmental Specifications

| Environment | | Specification |
|-------------------|-------------------------------|--------------------------------------|
| Temperature | Ambient operating temperature | 32 to 104°F (0 to 40°C) |
| | Ambient nonoperating | –40 to 158°F (–40 to 70°C) |
| Relative humidity | Nonoperating | 5 to 85% |
| Altitude | Operating | 0 to 13,123 feet (0 to 4,000 meters) |

Switch Dimensions

| Switch | Width | Depth | Height |
|--------------------|-----------------------|-----------------------|----------------------------|
| Cisco Nexus 9396PX | 17.5 inches (44.5 cm) | 22.5 inches (57.1 cm) | 3.5 inches (8.9 cm) (2 RU) |

Switch and Module Weights and Quantities

| Component | Weight per Unit | Quantity |
|---|--------------------|---|
| Cisco Nexus 9396PX Chassis (N9K-C9396PX) | 22.45 lb (10.2 kg) | 1 |
| Uplink Module | — | 1 |
| – M4PC-CFP2 | 2.6 lb (1.2 kg) | |
| – M6PQ and M6PQ-E | 2.0 lb (0.9 kg) | |
| – M12PQ | 3.12 lb (1.4 kg) | |
| Fan Modules (fan modules that are currently shipped with the switch). | — | 3 (2 for operations and 1 for redundancy) |
| – Port-side exhaust (blue) (N9K-C9300-FAN2-B) | 1.14 lb (0.5 kg) | |
| – Port-side intake (burgundy) (N9K-C9300-FAN2) | 1.14 lb (0.5 kg) | |
| Fan Modules (fan modules that were previously shipped with the switch). | — | 3 (2 for operations and 1 for redundancy) |
| | 0.92 lb (0.4 kg) | |
| – Port-side exhaust (blue) (N9K-C9300-FAN1-B) | 0.92 lb (0.4 kg) | |
| – Port-side intake (burgundy) (N9K-C9300-FAN1) | | |
| Power Supply module | — | 2 (1 for operations and 1 for redundancy) |
| – 650-W AC port-side exhaust (blue) (N9K-PAC-650W-B) | 2.42 lb (1.1 kg) | |
| | 2.42 lb (1.1 kg) | |
| – 650-W AC port-side intake (burgundy) (N9K-PAC-650W) | 2.42 lb (1.1 kg) | |
| | 2.42 lb (1.1 kg) | |
| – 1200-W HVAC/HVDC dual-direction (white) (N9K-PUV-1200W) | 2.42 lb (1.1 kg) | |
| | 2.42 lb (1.1 kg) | |
| – 930-W DC port-side exhaust (gray) (UCS-PSU-6332-DC) | | |
| – 930-W DC port-side intake (green) (UCSC-PSU-930WDC) | | |

Transceiver and Cable Specifications

To determine which transceivers, adapters, and cables are supported by this switch, see <https://www.cisco.com/c/en/us/support/interfaces-modules/transceiver-modules/products-device-support-tables-list.html>.

To see the transceiver specifications and installation information, see <https://www.cisco.com/c/en/us/support/interfaces-modules/transceiver-modules/products-device-support-tables-list.html>.

Switch Power Input Requirements

The following table lists the typical amount of power that the switch consumes. It also lists the maximum amount of power that you must provision for the switch and power supply for peak conditions.



Note Some power supplies have capabilities that are greater than the maximum power requirements for a switch. To determine the power consumption characteristics for the switch, use the typical and maximum requirements that are listed in the following table.

| Switch | Typical Power Consumption (AC or DC) | Maximum Power Consumption (AC or DC) | Heat Dissipation Requirement |
|--------------------|--------------------------------------|--------------------------------------|------------------------------|
| Cisco Nexus 9396PX | 232 W | 455 W | 1552.524 BTUs per hour |

Power Specifications

Power specifications include the specifications for each type of power supply module.

650-W AC Power Supply Specifications

These specifications apply to the following power supplies:

- N9K-PAC-650W
- N9K-PAC-650W-B

| Characteristic | Specification |
|----------------------------|---|
| AC input voltage | Nominal range: 100 and 240 VAC (Range: 90-132 VAC, 180-264 VAC) |
| AC input frequency | Nominal range: 50 to 60 Hz (Range: 47-63 Hz) |
| Maximum AC input current | 7.6 A at 100 VAC 3.65 A at 208 VAC |
| Maximum input volt-amperes | 760 A at 100 VAC |

| Characteristic | Specification |
|---------------------------------------|--|
| Maximum output power per power supply | 650 W |
| Maximum inrush current | 33 A (sub-cycle duration) |
| Maximum hold-up time | 12 ms at 650 W |
| Power supply output voltage | 12 VDC |
| Power supply standby voltage | 12 VDC |
| Efficiency rating | Climate Savers Platinum Efficiency (80Plus Platinum certified) |
| Form factor | RSP1 |

1200-W HVAC/HVDC Power Supply Specifications

These specifications apply to the 1200-W HVAC/HVDC (N9K-PUV-1200W) power supplies.

| Characteristic | Specification |
|--|---|
| Input voltage <ul style="list-style-type: none"> • AC (for 1230 W output) • DC (for 1230 W output) | Nominal (Range) <ul style="list-style-type: none"> • 200 to 277 VAC • -240 to -380 VDC |
| AC input frequency | Nominal: 50 to 60 Hz (Range: 47-63 Hz) |
| Maximum inrush current | 35 A (cold turn on); 70 A (hot turn on) |
| Maximum output Watts <ul style="list-style-type: none"> • For 200 to 277 VAC • For 192 to 400 VDC | Per power supply <ul style="list-style-type: none"> • 1230 W • 1230 W |
| Power supply output voltage <ul style="list-style-type: none"> • For 200 to 277 VAC • For 192 to 400 VDC | Per power supply <ul style="list-style-type: none"> • 12 VAC at 100 A • 12 VDC at 100 A |
| Power supply standby voltage | 12 V at 2.5 A |
| Efficiency rating | Climate Savers Platinum Efficiency (80Plus Platinum certified) |
| Form factor | RSP1 |

930-W DC Power Supply (Port-Side Intake) Specifications

These specifications apply to the 930-W DC (UCSC-PSU-930WDC) port-side intake power supplies.

| Characteristic | Specification |
|---------------------------------------|---|
| DC input voltage range | Nominal range: -48 to -60 VDC nominal (Range: -40 to -60 VDC) |
| Maximum DC input current | 23 A at -48 VDC |
| Maximum input W | 1104 W |
| Maximum output power per power supply | 930 W |
| Maximum inrush current | 35 A (sub-cycle duration) |
| Maximum hold-up time | 8 ms at 930 W |
| Power supply output voltage | 12 VDC |
| Power supply standby voltage | 12 VDC |
| Efficiency rating | Greater than 92% at 50% load |
| Form factor | RSP1 |

930-W DC Power Supply (Port-Side Exhaust) Specifications

These specifications apply to the 930-W DC (UCS-PSU-6332-DC) power supplies.

| Characteristic | Specification |
|---------------------------------------|--|
| Maximum DC input current | 23 A at -48 VDC |
| Maximum input W | 1104 W |
| Maximum output power per power supply | 930 W |
| Maximum inrush current | 35 A at +35° Celcius |
| Maximum hold-up time | 8 ms at 50 % load |
| Power supply output voltage | 12 VDC |
| Power supply standby voltage | 12 VDC |
| Efficiency rating | Climate Savers Platinum Efficiency (80Plus Platinum certified) |
| Form factor | 1U |

Power Cable Specifications



The following sections specify the power cables that you can order and use with this switch.

AC Power Cables Supported by NX-OS Mode Switches

| Power Type | Power Cord Part Number | Cord Set Description |
|---------------------------|------------------------|--|
| | CAB-C13-C14-2M | Power Cord Jumper, C13-C14 Connectors, 6.6 feet (2.0 m) |
| | CAB-C13-C14-AC | Power cord, C13 to C14 (recessed receptacle), 10 A, 9.8 feet (3 m) |
| | CAB-C13-CBN | Cabinet jumper power cord, 250 VAC, 10 A, C14-C13 connectors, 2.3 feet (0.7 m) |
| Argentina | CAB-250V-10A-AR | 250 V, 10 A, 8.2 feet (2.5 m) |
| Australia | CAB-9K10A-AU | 250 VAC, 10 A, 3112 plug, 8.2 feet (2.5 m) |
| Brazil | CAB-250V-10A-BR | 250 V, 10 A, 6.9 feet (2.1 m) |
| European Union | CAB-9K10A-EU | 250 VAC, 10 A, CEE 7/7 plug, 8.2 feet (2.5 m) |
| India | CAB-IND-10A | 10 A, 8.2 feet (2.5 m) |
| Israel | CAB-250V-10A-IS | 250 V, 10 A, 8.2 feet (2.5 m) |
| Italy | CAB-9K10A-IT | 250 VAC, 10 A, CEI 23-16/VII plug, 8.2 feet (2.5 m) |
| North America | CAB-9K12A-NA | 125 VAC, 13 A, NEMA 5-15 plug, 8.2 feet (2.5 m) |
| North America | CAB-AC-L620-C13 | NEMA L6-20-C13, 6.6 feet (2.0 m) |
| North America | CAB-N5K6A-NA | 200/240V, 6A, 8.2 feet (2.5 m) |
| Peoples Republic of China | CAB-250V-10A-CN | 250 V, 10 A, 8.2 feet (2.5 m) |
| South Africa | CAB-250V-10A-ID | 250 V, 10 A, 8.2 feet (2.5 m) |
| Switzerland | CAB-9K10A-SW | 250 VAC, 10 A, MP232 plug, 8.2 feet (2.5 m) |
| United Kingdom | CAB-9K10A-UK | 250 VAC, 10 A, BS1363 plug (13 A fuse), 8.2 (2.5 m) |

| Power Type | Power Cord Part Number | Cord Set Description |
|---|------------------------|------------------------------------|
| All except Argentina, Brazil, and Japan | NO-POWER-CORD | No power cord included with switch |

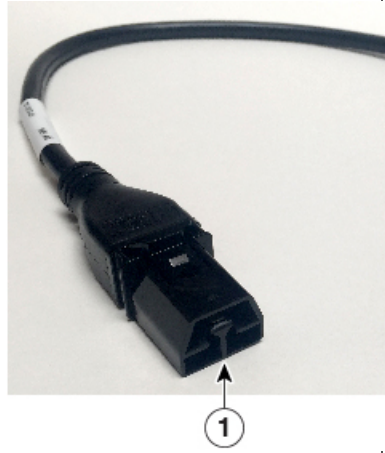
HVAC/HVDC Power Cables Supported by ACI-Mode and NX-OS Mode Switches

| Part Number | Cord Set Description | Photo |
|------------------|--|---|
| CAB-HVAC-SD-0.6M | HVAC 2-foot (0.6 m) cable with Saf-D-Grid and SD connectors |  |
| CAB-HVAC-C14-2M | HVAC 6.6-foot (2.0 m) cable with Saf-D-Grid and C14 connector (use for up to 240 V) |  |
| CAB-HVAC-RT-0.6M | HVAC 2-foot (0.6 m) cable with Saf-D-Grid and RT connector |  |

| Part Number | Cord Set Description | Photo |
|----------------|---|---|
| CAB-HVDC-3T-2M | HVDC 6.6-foot (2.0 m) cable with Saf-D-Grid and three terminal connectors |  |
| NO-POWER-CORD | All except Argentina, Brazil, and Japan No power cord included with switch | Not applicable |

Table 1: HVAC/HVDC Power Cables Callout Table

| | |
|---|--|
| 1 | Connect this end to the power supply unit. |
|---|--|

DC Power Cable Specifications

| Power Supply | Power Cord | Cord Set Description |
|---|---------------------|---|
| UCSC-PSU-930WDC (port-side intake airflow) | (customer supplied) | 8 AWG insulated cable (10 AWG minimum) for each power supply |
| UCS-PSU-6332-DC (port-side exhaust airflow) | CAB-48DC-40A-8AWG | 8-AWG cable with 3-pin keyed power supply connector and three wires (power source connection) |
| All except Argentina, Brazil, and Japan | NO-POWER-CORD | No power cord included with switch |

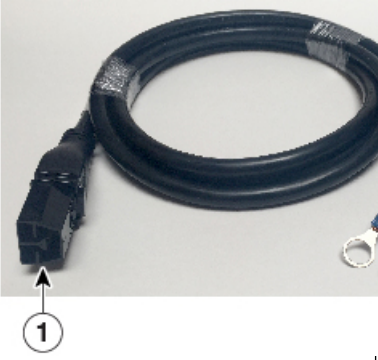
Regulatory Standards Compliance Specifications

The following table lists the regulatory standards compliance for the switch.

Table 2: Regulatory Standards Compliance: Safety and EMC

| Specification | Description |
|-----------------------|---|
| Regulatory compliance | Products should comply with CE Markings according to directives 2004/108/EC and 2006/95/EC. |

| Specification | Description |
|----------------|---|
| Safety | <ul style="list-style-type: none"> • CAN/CSA-C22.2 No. 60950-1 Second Edition • EN 60950-1 Second Edition • IEC 60950-1 Second Edition • AS/NZS 60950-1 • GB4943 |
| EMC: Emissions | <ul style="list-style-type: none"> • 47CFR Part 15 (CFR 47) Class A • AS/NZS CISPR22 Class A • CISPR22 Class A • EN55022 Class A • ICES003 Class A • VCCI Class A • EN61000-3-2 • EN61000-3-3 • KN22 Class A • CNS13438 Class A |
| EMC: Immunity | <ul style="list-style-type: none"> • EN55024 • CISPR24 • EN300386 • KN 61000-4 series |
| RoHS | The product is RoH-6 compliant with exceptions for leaded-ball grid-array (BGA) balls and lead press-fit connectors. |



APPENDIX C

LEDs

- [Switch Chassis LEDs, on page 59](#)
- [Uplink Module LEDs, on page 60](#)
- [Fan Module LEDs, on page 60](#)
- [Power Supply LEDs, on page 61](#)

Switch Chassis LEDs

The BCN, STS, and ENV, LEDs are located on the left side of the front of the switch. The port LEDs appear as triangles pointing up or down to the nearest port.

| LED | Color | Status |
|-----|----------------|---|
| BCN | Flashing blue | The operator has activated this LED to identify this switch in the chassis. |
| | Off | This switch is not being identified. |
| STS | Green | The switch is operational. |
| | Flashing amber | The switch is booting up. |
| | Amber | Temperature exceeds the minor alarm threshold. |
| | Red | Temperature exceeds the minor alarm threshold. |
| | Off | The switch is not receiving power. |
| ENV | Green | Fans and power supply modules are operational. |
| | Amber | At least one fan or power supply module is not operating. |

| LED | Color | Status |
|--------|-------|---|
| (port) | Green | Port admin state is 'Enabled', SFP is present and the interface is connected (that is, cabled, and the link is up). |
| | Amber | Port admin state is 'Disabled', or the SFP is absent, or both. |
| | Off | Port admin state is 'Enabled' and SFP is present, but interface is not connected. |

Uplink Module LEDs

The Status (STS) LED is located on the left side of the uplink module. There is an ACT LED located below each two uplink ports. Next to each ACT LED are two triangular port LEDs that point to the top or bottom to identify their port as being the top or bottom port.

| LED | Color | Status |
|--------|------------|--|
| STS | Green | This module is operational. |
| | Red | Temperature is not operational. |
| | Off | The module is not receiving power. |
| ACT | On (white) | The two ports above this LED are enabled. |
| | Off | The two ports above this LED are not enabled. |
| (port) | Green | The port is connected with a transceiver or other connector. |
| | Off | The port is not connected. |

Fan Module LEDs

The fan module LED is located below the air holes on the front of the module.

| LED | Color | Status |
|-----|-------|---|
| STS | Green | The fan module is operational. |
| | Red | The fan module is not operational (fan is probably not functional). |
| | Off | Fan module is not receiving power. |

Power Supply LEDs

The power supply LEDs are located on the left front portion of the power supply. Combinations of states indicated by the Okay (🟢) and Fault (🟡) LEDs indicate the status for the module as shown in the following table.

| 🟢 LED | 🟡 LED | Status |
|----------------|----------------|--|
| Green | Off | Power supply is on and outputting power to the switch. |
| Flashing green | Off | Power supply is connected to a power source but not outputting power to the switch—power supply might not be installed in the chassis. |
| Off | Off | Power supply is not receiving power. |
| Green | Flashing amber | Power supply warning—possibly one of the following conditions: <ul style="list-style-type: none"> • High voltage • High power • Low voltage • Power supply installed in chassis but not connected to a power source • Slow power supply fan |



APPENDIX **D**

Additional Kits

- [Rack Mount Kit N9K-C9300-RMK, on page 63](#)

Rack Mount Kit N9K-C9300-RMK

The following table lists and illustrates the contents for the 2-RU rack-mount kit (N9K-C9300-RMK).

| Illustration | Description | Quantity |
|--------------|---|----------|
| | Rack-mount kit <ul style="list-style-type: none"> • Bottom support rails (2) • Front-mount brackets (2) | 1 |



APPENDIX **E**

Site Preparation and Maintenance Records

- [Site Preparation Checklist, on page 65](#)
- [Contact and Site Information, on page 66](#)
- [Chassis and Module Information, on page 67](#)

Site Preparation Checklist

Planning the location and layout of your equipment rack or cabinet is essential for successful switch operation, ventilation, and accessibility.

The following table lists the site planning tasks that we recommend that you complete before you install the switch. Your completion of each task ensures a successful switch installation.

| Planning Activity | Verification Time and Date |
|---------------------------|----------------------------|
| Space evaluation: | |
| Space and layout | |
| Floor covering | |
| Impact and vibration | |
| Lighting | |
| Physical access | |
| Maintenance access | |
| Environmental evaluation: | |
| Ambient temperature | |
| Humidity | |
| Altitude | |
| Atmospheric contamination | |
| Airflow | |

| Planning Activity | Verification Time and Date |
|--|----------------------------|
| Power evaluation: | |
| Input power type | |
| Power receptacles | |
| Receptacle proximity to the equipment | |
| Dedicated (separate) circuits for power redundancy | |
| UPS for power failures | |
| Grounding: proper wire gauge and lugs | |
| Circuit breaker size | |
| Grounding evaluation: | |
| Data center ground | |
| Cable and interface equipment evaluation: | |
| Cable type | |
| Connector type | |
| Cable distance limitations | |
| Interface equipment (transceivers) | |
| EMI evaluation: | |
| Distance limitations for signaling | |
| Site wiring | |
| RFI levels | |

Contact and Site Information

Use the following worksheet to record contact and site information for the installation.

| | |
|----------------|--|
| Contact person | |
| Contact phone | |

| | |
|----------------------|--|
| Contact e-mail | |
| Building/site name | |
| Data center location | |
| Floor location | |
| Address (line 1) | |
| Address (line 2) | |
| City | |
| State/Provence | |
| Contact person | |
| ZIP/postal code | |
| Country | |

Chassis and Module Information

Use the following worksheet to record information about the switch.

| | |
|-----------------------|--|
| Contract number | |
| Chassis serial number | |
| Product number | |

Use the following worksheet to record network-related information.

| | |
|------------------------|--|
| Switch IP address | |
| Switch IP netmask | |
| Hostname | |
| Domain name | |
| IP broadcast address | |
| Gateway/router address | |
| DNS address | |

Use the following worksheet to record information about the modules in the switch.

| Module Slot | Module Type | Module Serial Number | Notes |
|---------------|-------------|----------------------|-------|
| Uplink module | | | |

| Module Slot | Module Type | Module Serial Number | Notes |
|--------------------|--------------------|-----------------------------|--------------|
| Fan module 1 | | | |
| Fan module 2 | | | |
| Fan module 3 | | | |
| Power Supply 1 | | | |
| Power Supply 2 | | | |