



Cisco Nexus 6000 Series Hardware Installation Guide

July 2016

Americas Headquarters
Cisco Systems, Inc.
170 West Tasman Drive
San Jose, CA 95134-1706
USA
<http://www.cisco.com>
Tel: 408 526-4000
800 553-NETS (6387)
Fax: 408 527-0883

THE SPECIFICATIONS AND INFORMATION REGARDING THE PRODUCTS IN THIS MANUAL ARE SUBJECT TO CHANGE WITHOUT NOTICE. ALL STATEMENTS, INFORMATION, AND RECOMMENDATIONS IN THIS MANUAL ARE BELIEVED TO BE ACCURATE BUT ARE PRESENTED WITHOUT WARRANTY OF ANY KIND, EXPRESS OR IMPLIED. USERS MUST TAKE FULL RESPONSIBILITY FOR THEIR APPLICATION OF ANY PRODUCTS.

THE SOFTWARE LICENSE AND LIMITED WARRANTY FOR THE ACCOMPANYING PRODUCT ARE SET FORTH IN THE INFORMATION PACKET THAT SHIPPED WITH THE PRODUCT AND ARE INCORPORATED HEREIN BY THIS REFERENCE. IF YOU ARE UNABLE TO LOCATE THE SOFTWARE LICENSE OR LIMITED WARRANTY, CONTACT YOUR CISCO REPRESENTATIVE FOR A COPY.

The following information is for FCC compliance of Class A devices: This equipment has been tested and found to comply with the limits for a Class A digital device, pursuant to part 15 of the FCC rules. These limits are designed to provide reasonable protection against harmful interference when the equipment is operated in a commercial environment. This equipment generates, uses, and can radiate radio-frequency energy and, if not installed and used in accordance with the instruction manual, may cause harmful interference to radio communications. Operation of this equipment in a residential area is likely to cause harmful interference, in which case users will be required to correct the interference at their own expense.

The following information is for FCC compliance of Class B devices: The equipment described in this manual generates and may radiate radio-frequency energy. If it is not installed in accordance with Cisco's installation instructions, it may cause interference with radio and television reception. This equipment has been tested and found to comply with the limits for a Class B digital device in accordance with the specifications in part 15 of the FCC rules. These specifications are designed to provide reasonable protection against such interference in a residential installation. However, there is no guarantee that interference will not occur in a particular installation.

Modifying the equipment without Cisco's written authorization may result in the equipment no longer complying with FCC requirements for Class A or Class B digital devices. In that event, your right to use the equipment may be limited by FCC regulations, and you may be required to correct any interference to radio or television communications at your own expense.

You can determine whether your equipment is causing interference by turning it off. If the interference stops, it was probably caused by the Cisco equipment or one of its peripheral devices. If the equipment causes interference to radio or television reception, try to correct the interference by using one or more of the following measures:

- Turn the television or radio antenna until the interference stops.
- Move the equipment to one side or the other of the television or radio.
- Move the equipment farther away from the television or radio.
- Plug the equipment into an outlet that is on a different circuit from the television or radio. (That is, make certain the equipment and the television or radio are on circuits controlled by different circuit breakers or fuses.)

Modifications to this product not authorized by Cisco Systems, Inc. could void the FCC approval and negate your authority to operate the product.

The Cisco implementation of TCP header compression is an adaptation of a program developed by the University of California, Berkeley (UCB) as part of UCB's public domain version of the UNIX operating system. All rights reserved. Copyright © 1981, Regents of the University of California.

NOTWITHSTANDING ANY OTHER WARRANTY HEREIN, ALL DOCUMENT FILES AND SOFTWARE OF THESE SUPPLIERS ARE PROVIDED "AS IS" WITH ALL FAULTS. CISCO AND THE ABOVE-NAMED SUPPLIERS DISCLAIM ALL WARRANTIES, EXPRESSED OR IMPLIED, INCLUDING, WITHOUT LIMITATION, THOSE OF MERCHANTABILITY, FITNESS FOR A PARTICULAR PURPOSE AND NONINFRINGEMENT OR ARISING FROM A COURSE OF DEALING, USAGE, OR TRADE PRACTICE.

IN NO EVENT SHALL CISCO OR ITS SUPPLIERS BE LIABLE FOR ANY INDIRECT, SPECIAL, CONSEQUENTIAL, OR INCIDENTAL DAMAGES, INCLUDING, WITHOUT LIMITATION, LOST PROFITS OR LOSS OR DAMAGE TO DATA ARISING OUT OF THE USE OR INABILITY TO USE THIS MANUAL, EVEN IF CISCO OR ITS SUPPLIERS HAVE BEEN ADVISED OF THE POSSIBILITY OF SUCH DAMAGES.

Cisco and the Cisco logo are trademarks or registered trademarks of Cisco and/or its affiliates in the U.S. and other countries. To view a list of Cisco trademarks, go to this URL: www.cisco.com/go/trademarks. Third-party trademarks mentioned are the property of their respective owners. The use of the word partner does not imply a partnership relationship between Cisco and any other company. (1721R)

Any Internet Protocol (IP) addresses used in this document are not intended to be actual addresses. Any examples, command display output, and figures included in the document are shown for illustrative purposes only. Any use of actual IP addresses in illustrative content is unintentional and coincidental.

© 2008-2016 Cisco Systems, Inc. All rights reserved.



CONTENTS

Preface vii

Audience	vii
Organization	vii
Conventions	viii
Related Documentation	xiv
Obtaining Documentation and Submitting a Service Request	xiv

CHAPTER 1

Overview 1-1

Cisco Nexus 6001 Switch	1-1
Features	1-1
Chassis	1-2
Power Supply	1-3
Fan Modules	1-4
Transceivers	1-4
1 and 10 Gigabit Ethernet SFP+ Transceiver Support Matrix	1-5
40 Gigabit Ethernet QSFP+ Transceiver Support Matrix	1-5
Cisco Nexus 6004 Switch	1-6
Features	1-6
Chassis	1-7
Expansion Modules	1-9
N6004X-M20UP	1-10
N5696-M4C	1-10
Ports	1-11
Power Supply	1-12
Fan Module	1-13
Transceivers	1-15
Transceiver Support Matrix	1-15

CHAPTER 2

Installing the Cisco Nexus 6000 Series Switches 2-1

Preparing for Installation	2-2
Installation Options with Racks and Cabinets	2-2
Airflow Direction	2-2
Chassis Weight	2-2
Installation Guidelines	2-3

- Required Equipment 2-4
- Unpacking and Inspecting the Switch 2-4
- Installing the Switch 2-5
 - Installing a Cisco Nexus 6000 switch 2-5
- Grounding the Switch 2-7
 - Proper Grounding Practices 2-7
 - Preventing Electrostatic Discharge Damage 2-9
 - Establishing the System Ground 2-10
 - Required Tools and Equipment 2-11
 - Grounding the Cisco Nexus 6000 Series Chassis 2-11
- Starting the Switch 2-12
- Installing a Reverse Airflow System for the Cisco Nexus 6004 Switch 2-14
- Removing Fan Shutters 2-15

CHAPTER 3

Connecting the Switch 3-1

- Preparing for Network Connections 3-2
- Connecting to the Console Port 3-2
- Connecting to the Ethernet Connector Port 3-3
- Connecting to an Ethernet Port 3-3
 - Installing and Replacing Transceivers 3-3
 - Installing a Transceiver 3-3
 - Replacing a Transceiver 3-4
 - Installing Cables into Transceivers 3-5
 - Installing a Cable into a Transceiver 3-5
 - Replacing a Cable for a Transceiver 3-5

CHAPTER 4

Replacing Components 4-1

- Replacing Expansion Modules 4-1
 - Removing an Expansion Module from a Cisco Nexus 6000 Platform Chassis 4-1
 - Installing an Expansion Module in a Cisco Nexus 6000 Platform Chassis 4-2
- Replacing LEMs 4-2
 - Removing a LEM 4-2
 - Installing a LEM 4-3
- Replacing Modules 4-3
 - Removing a Module 4-3
 - Installing a Module 4-3
- Replacing or Installing Power Supplies 4-4
 - Removing a Power Supply 4-4

Installing a Power Supply	4-5
Wiring a DC Power Connector	4-5
Replacing a Fan Module	4-7
Removing a Fan Module	4-8
Installing a Fan Module	4-8
Removing the Cisco Nexus 6000 Platform Chassis	4-8
Repacking Cisco Nexus 6000 Platform Switch Components or Cisco Nexus Platform Switch Components for Return Shipment	4-9

APPENDIX A**Cabinet and Rack Installation** A-1

Cabinet and Rack Requirements	A-1
General Requirements for Cabinets and Racks	A-1
Requirements Specific to Perforated Cabinets	A-2
Cable Management Guidelines	A-2

APPENDIX B**Technical Specifications** B-1

Switch Specifications	B-1
Environmental Specifications	B-2
Expansion Module Specifications	B-2
Power Specifications	B-3
Specifications for the Cisco Nexus 6001 Power Supply	B-3
Specifications for the Cisco Nexus 6004 Power Supply	B-4

APPENDIX C**Cable and Port Specifications** C-1

Cable RJ-45 Connector Pinouts	C-1
Console Port	C-2
Supported Power Cords and Plugs	C-2
Jumper Power Cord	C-8

APPENDIX D**LEDs** D-1

Chassis and Module LEDs for the Cisco Nexus 6000 Series Switches	D-1
Chassis and Module LED Descriptions	D-1
Conditions Indicated by the Power Supply LEDs	D-2
Port LEDs	D-2
Ethernet Port LEDs	D-3
Ethernet and Fibre Channel LEDs	D-3

APPENDIX E

Troubleshooting Hardware Components E-1

- Overview E-1
- Switch Hardware Best Practices E-1
 - Installation Best Practices E-2
 - Initialization Best Practices E-2
 - Switch Operation Best Practices E-2
- Power Supply Conditions E-2

APPENDIX F

Accessory Kits F-1

- Cisco Nexus 6001 Switch Accessory Kit F-1
- Cisco Nexus 6004 Switch Accessory Kit F-1

APPENDIX G

Site Planning and Maintenance Records G-1

- Site Preparation Checklist G-1
- Contact and Site Information G-3
- Chassis and Module Information G-4



Preface

This preface describes the audience, organization, and conventions of the *Cisco Nexus 6000 Series Hardware Installation Guide*. It also provides information on how to obtain related documentation.

Audience

To use this installation guide, you must be familiar with electronic circuitry and wiring practices and preferably be an electronic or electromechanical technician.

Organization

This guide is organized as follows:

Chapter and Title	Description
Chapter 1, “ Overview ”	Provides an overview of the Cisco Nexus 6000 Series switches.
Chapter 2, “ Installing the Cisco Nexus 6000 Series Switches ”	Describes how to install the Cisco Nexus 6000 switches, and how to install modules, power supplies, and fan assemblies.
Chapter 3, “ Connecting the Switch ”	Describes how to connect the Cisco Nexus 6000 Series switches.
Chapter 4, “ Replacing Components ”	Describes how to remove and install components for the Cisco Nexus 6000 Series switches.
Appendix A, “ Cabinet and Rack Installation ”	Provides guidelines for selecting an enclosed cabinet, and rack installation.
Appendix B, “ Technical Specifications ”	Lists specifications for the Cisco Nexus 6000 Series switches and components including modules, power supplies, and transceivers.
Appendix C, “ Cable and Port Specifications ”	Lists cable and port specifications for the Cisco Nexus 6000 Series switches.
Appendix D, “ LEDs ”	Provides installation troubleshooting information for the Cisco Nexus 6000 Series switches.
Appendix E, “ Troubleshooting Hardware Components ”	Provides installation troubleshooting information for the Cisco Nexus 6000 Series switches.

Chapter and Title	Description
Appendix F, “ Accessory Kits ”	Provides installation troubleshooting information for the Cisco Nexus 6000 Series switches.
Appendix G, “ Site Planning and Maintenance Records ”	Provides site planning and maintenance records.

Conventions

This document uses the following conventions for notes, cautions, and safety warnings.

Notes and Cautions contain important information that you should be aware of.



Note

Means *reader take note*. Notes contain helpful suggestions or references to material that are not covered in the publication.



Caution

Means *reader be careful*. You are capable of doing something that might result in equipment damage or loss of data.

Safety warnings appear throughout this publication in procedures that, if performed incorrectly, can cause physical injuries. A warning symbol precedes each warning statement.



Warning

IMPORTANT SAFETY INSTRUCTIONS

This warning symbol means danger. You are in a situation that could cause bodily injury. Before you work on any equipment, be aware of the hazards involved with electrical circuitry and be familiar with standard practices for preventing accidents. Use the statement number provided at the end of each warning to locate its translation in the translated safety warnings that accompanied this device. Statement 1071

SAVE THESE INSTRUCTIONS

Waarschuwing

BELANGRIJKE VEILIGHEIDSINSTRUCTIES

Dit waarschuwingssymbool betekent gevaar. U verkeert in een situatie die lichamelijk letsel kan veroorzaken. Voordat u aan enige apparatuur gaat werken, dient u zich bewust te zijn van de bij elektrische schakelingen betrokken risico's en dient u op de hoogte te zijn van de standaard praktijken om ongelukken te voorkomen. Gebruik het nummer van de verklaring onderaan de waarschuwing als u een vertaling van de waarschuwing die bij het apparaat wordt geleverd, wilt raadplegen.

BEWAAR DEZE INSTRUCTIES

Varoitus TÄRKEITÄ TURVALLISUUSOHJEITA

Tämä varoitusmerkki merkitsee vaaraa. Tilanne voi aiheuttaa ruumiillisia vammoja. Ennen kuin käsittelet laitteistoa, huomioi sähköpiirien käsittelemiseen liittyvät riskit ja tutustu onnettomuuksien yleisiin ehkäisytapoihin. Turvallisuusvaroitusten käännökset löytyvät laitteen mukana toimitettujen käännettyjen turvallisuusvaroitusten joukosta varoitusten lopussa näkyvien lausuntonumeroiden avulla.

SÄILYTÄ NÄMÄ OHJEET**Attention IMPORTANTES INFORMATIONS DE SÉCURITÉ**

Ce symbole d'avertissement indique un danger. Vous vous trouvez dans une situation pouvant entraîner des blessures ou des dommages corporels. Avant de travailler sur un équipement, soyez conscient des dangers liés aux circuits électriques et familiarisez-vous avec les procédures couramment utilisées pour éviter les accidents. Pour prendre connaissance des traductions des avertissements figurant dans les consignes de sécurité traduites qui accompagnent cet appareil, référez-vous au numéro de l'instruction situé à la fin de chaque avertissement.

CONSERVEZ CES INFORMATIONS**Warnung WICHTIGE SICHERHEITSHINWEISE**

Dieses Warnsymbol bedeutet Gefahr. Sie befinden sich in einer Situation, die zu Verletzungen führen kann. Machen Sie sich vor der Arbeit mit Geräten mit den Gefahren elektrischer Schaltungen und den üblichen Verfahren zur Vorbeugung vor Unfällen vertraut. Suchen Sie mit der am Ende jeder Warnung angegebenen Anweisungsnummer nach der jeweiligen Übersetzung in den übersetzten Sicherheitshinweisen, die zusammen mit diesem Gerät ausgeliefert wurden.

BEWAHREN SIE DIESE HINWEISE GUT AUF.**Avvertenza IMPORTANTI ISTRUZIONI SULLA SICUREZZA**

Questo simbolo di avvertenza indica un pericolo. La situazione potrebbe causare infortuni alle persone. Prima di intervenire su qualsiasi apparecchiatura, occorre essere al corrente dei pericoli relativi ai circuiti elettrici e conoscere le procedure standard per la prevenzione di incidenti. Utilizzare il numero di istruzione presente alla fine di ciascuna avvertenza per individuare le traduzioni delle avvertenze riportate in questo documento.

CONSERVARE QUESTE ISTRUZIONI**Advarsel VIKTIGE SIKKERHETSINSTRUKSJONER**

Dette advarselssymbolet betyr fare. Du er i en situasjon som kan føre til skade på person. Før du begynner å arbeide med noe av utstyret, må du være oppmerksom på farene forbundet med elektriske kretser, og kjenne til standardprosedyrer for å forhindre ulykker. Bruk nummeret i slutten av hver advarsel for å finne oversettelsen i de oversatte sikkerhetsadvarslene som fulgte med denne enheten.

TA VARE PÅ DISSE INSTRUKSJONENE

Aviso INSTRUÇÕES IMPORTANTES DE SEGURANÇA

Este símbolo de aviso significa perigo. Você está em uma situação que poderá ser causadora de lesões corporais. Antes de iniciar a utilização de qualquer equipamento, tenha conhecimento dos perigos envolvidos no manuseio de circuitos elétricos e familiarize-se com as práticas habituais de prevenção de acidentes. Utilize o número da instrução fornecido ao final de cada aviso para localizar sua tradução nos avisos de segurança traduzidos que acompanham este dispositivo.

GUARDE ESTAS INSTRUÇÕES**¡Advertencia! INSTRUCCIONES IMPORTANTES DE SEGURIDAD**

Este símbolo de aviso indica peligro. Existe riesgo para su integridad física. Antes de manipular cualquier equipo, considere los riesgos de la corriente eléctrica y familiarícese con los procedimientos estándar de prevención de accidentes. Al final de cada advertencia encontrará el número que le ayudará a encontrar el texto traducido en el apartado de traducciones que acompaña a este dispositivo.

GUARDE ESTAS INSTRUCCIONES**Varning! VIKTIGA SÄKERHETSANVISNINGAR**

Denna varningssignal signalerar fara. Du befinner dig i en situation som kan leda till personskada. Innan du utför arbete på någon utrustning måste du vara medveten om farorna med elkretsar och känna till vanliga förfaranden för att förebygga olyckor. Använd det nummer som finns i slutet av varje varning för att hitta dess översättning i de översatta säkerhetsvarningar som medföljer denna anordning.

SPARA DESSA ANVISNINGAR**Figyelem FONTOS BIZTONSÁGI ELOÍRÁSOK**

Ez a figyelmeztető jel veszélyre utal. Sérülésveszélyt rejte helyzetben van. Mielőtt bármely berendezésen munkát végezte, legyen figyelemmel az elektromos áramkörök okozta kockázatokra, és ismerkedjen meg a szokásos balesetvédelmi eljárásokkal. A kiadványban szereplő figyelmeztetések fordítása a készülékhez mellékelt biztonsági figyelmeztetések között található; a fordítás az egyes figyelmeztetések végén látható szám alapján kereshető meg.

ORIZZE MEG EZEKET AZ UTASÍTÁSOKAT!**Предупреждение ВАЖНЫЕ ИНСТРУКЦИИ ПО СОБЛЮДЕНИЮ ТЕХНИКИ БЕЗОПАСНОСТИ**

Этот символ предупреждения обозначает опасность. То есть имеет место ситуация, в которой следует опасаться телесных повреждений. Перед эксплуатацией оборудования выясните, каким опасностям может подвергаться пользователь при использовании электрических цепей, и ознакомьтесь с правилами техники безопасности для предотвращения возможных несчастных случаев. Воспользуйтесь номером заявления, приведенным в конце каждого предупреждения, чтобы найти его переведенный вариант в переводе предупреждений по безопасности, прилагаемом к данному устройству.

СОХРАНИТЕ ЭТИ ИНСТРУКЦИИ

警告 重要的安全性说明

此警告符号代表危险。您正处于可能受到严重伤害的工作环境中。在您使用设备开始工作之前，必须充分意识到触电的危险，并熟练掌握防止事故发生的标准工作程序。请根据每项警告结尾提供的声明号码来找到此设备的安全性警告说明的翻译文本。

请保存这些安全性说明

警告 安全上の重要な注意事項

「危険」の意味です。人身事故を予防するための注意事項が記述されています。装置の取り扱い作業を行うときは、電気回路の危険性に注意し、一般的な事故防止策に留意してください。警告の各国語版は、各注意事項の番号を基に、装置に付属の「Translated Safety Warnings」を参照してください。

これらの注意事項を保管しておいてください。

주의 중요 안전 지침

이 경고 기호는 위험을 나타냅니다. 작업자가 신체 부상을 일으킬 수 있는 위험한 환경에 있습니다. 장비에 작업을 수행하기 전에 전기 회로와 관련된 위험을 숙지하고 표준 작업 관례를 숙지하여 사고를 방지하십시오. 각 경고의 마지막 부분에 있는 경고문 번호를 참조하여 이 장치와 함께 제공되는 번역된 안전 경고문에서 해당 번역문을 찾으십시오.

이 지시 사항을 보관하십시오.

Aviso **INSTRUÇÕES IMPORTANTES DE SEGURANÇA**

Este símbolo de aviso significa perigo. Você se encontra em uma situação em que há risco de lesões corporais. Antes de trabalhar com qualquer equipamento, esteja ciente dos riscos que envolvem os circuitos elétricos e familiarize-se com as práticas padrão de prevenção de acidentes. Use o número da declaração fornecido ao final de cada aviso para localizar sua tradução nos avisos de segurança traduzidos que acompanham o dispositivo.

GUARDE ESTAS INSTRUÇÕES**Advarsel** **VIGTIGE SIKKERHEDSANVISNINGER**

Dette advarselssymbol betyder fare. Du befinder dig i en situation med risiko for legemeskade. Før du begynder arbejde på udstyr, skal du være opmærksom på de involverede risici, der er ved elektriske kredsløb, og du skal sætte dig ind i standardprocedurer til undgåelse af ulykker. Brug erklæringsnummeret efter hver advarsel for at finde oversættelsen i de oversatte advarsler, der fulgte med denne enhed.

GEM DISSE ANVISNINGER**تحذير****إرشادات الأمان الهامة**

يوضح رمز التحذير هذا وجود خطر. وهذا يعني أنك متواجد في مكان قد ينتج عنه التعرض لإصابات. قبل بدء العمل، احذر مخاطر التعرض للصدمات الكهربائية وكن على علم بالإجراءات القياسية للحيلولة دون وقوع أي حوادث. استخدم رقم البيان الموجود في أحر كل تحذير لتحديد مكان ترجمته داخل تحذيرات الأمان المترجمة التي تأتي مع الجهاز. قم بحفظ هذه الإرشادات

Upozorenje VAŽNE SIGURNOSNE NAPOMENE

Ovaj simbol upozorenja predstavlja opasnost. Nalazite se u situaciji koja može prouzročiti tjelesne ozljede. Prije rada s bilo kojim uređajem, morate razumjeti opasnosti vezane uz električne sklopove, te biti upoznati sa standardnim načinima izbjegavanja nesreća. U prevedenim sigurnosnim upozorenjima, priloženima uz uređaj, možete prema broju koji se nalazi uz pojedino upozorenje pronaći i njegov prijevod.

SAČUVAJTE OVE UPUTE**Upozornění DŮLEŽITÉ BEZPEČNOSTNÍ POKYNY**

Tento upozorňující symbol označuje nebezpečí. Jste v situaci, která by mohla způsobit nebezpečí úrazu. Před prací na jakémkoliv vybavení si uvědomte nebezpečí související s elektrickými obvody a seznamte se se standardními opatřeními pro předcházení úrazům. Podle čísla na konci každého upozornění vyhledejte jeho překlad v přeložených bezpečnostních upozorněních, která jsou přiložena k zařízení.

USCHOVEJTE TYTO POKYNY**Προειδοποίηση ΣΗΜΑΝΤΙΚΕΣ ΟΔΗΓΙΕΣ ΑΣΦΑΛΕΙΑΣ**

Αυτό το προειδοποιητικό σύμβολο σημαίνει κίνδυνο. Βρίσκεστε σε κατάσταση που μπορεί να προκαλέσει τραυματισμό. Πριν εργαστείτε σε οποιοδήποτε εξοπλισμό, να έχετε υπόψη σας τους κινδύνους που σχετίζονται με τα ηλεκτρικά κυκλώματα και να έχετε εξοικειωθεί με τις συνήθειες πρακτικές για την αποφυγή ατυχημάτων. Χρησιμοποιήστε τον αριθμό δήλωσης που παρέχεται στο τέλος κάθε προειδοποίησης, για να εντοπίσετε τη μετάφρασή της στις μεταφρασμένες προειδοποιήσεις ασφαλείας που συνοδεύουν τη συσκευή.

ΦΥΛΑΞΤΕ ΑΥΤΕΣ ΤΙΣ ΟΔΗΓΙΕΣ**אזהרה****הוראות בטיחות חשובות**

סימן אזהרה זה מסמל סכנה. אתה נמצא במצב העלול לגרום לפציעה. לפני שתעבוד עם ציוד כלשהו, עליך להיות מודע לסכנות הכרוכות במעגלים חשמליים ולהכיר את הנהלים המקובלים למניעת תאונות. השתמש במספר ההוראה המסופק בסופה של כל אזהרה כדי לאתר את התרגום באזהרות הבטיחות המתורגמות שמצורפות להתקן.

שמור הוראות אלה**предупреждение ВАЖНИ БЕЗБЕДНОСНИ НАПАТСТВИЈА**

Симболот за предупредување значи опасност. Се наоѓате во ситуација што може да предизвика телесни повреди. Пред да работите со опремата, бидете свесни за ризикот што постои кај електричните кола и треба да ги познавате стандардните постапки за спречување на несреќни случаи. Искористете го бројот на изјавата што се наоѓа на крајот на секое предупредување за да го најдете неговиот период во prevedените безбедносни предупредувања што се испорачани со уредот.

ЧУВАЈТЕ ГИ ОБИЕ НАПАТСТВИЈА

Ostrzeżenie WAŻNE INSTRUKCJE DOTYCZĄCE BEZPIECZEŃSTWA

Ten symbol ostrzeżenia oznacza niebezpieczeństwo. Zachodzi sytuacja, która może powodować obrażenia ciała. Przed przystąpieniem do prac przy urządzeniach należy zapoznać się z zagrożeniami związanymi z układami elektrycznymi oraz ze standardowymi środkami zapobiegania wypadkom. Na końcu każdego ostrzeżenia podano numer, na podstawie którego można odszukać tłumaczenie tego ostrzeżenia w dołączonym do urządzenia dokumencie z tłumaczeniami ostrzeżeń.

NINIEJSZE INSTRUKCJE NALEŻY ZACHOWAĆ**Upozornenie DÔLEŽITÉ BEZPEČNOSTNÉ POKYNY**

Tento varovný symbol označuje nebezpečenstvo. Nachádzate sa v situácii s nebezpečenstvom úrazu. Pred prácou na akomkoľvek vybavení si uvedomte nebezpečenstvo súvisiace s elektrickými obvodmi a oboznámte sa so štandardnými opatreniami na predchádzanie úrazom. Podľa čísla na konci každého upozornenia vyhľadajte jeho preklad v preložených bezpečnostných upozorneniach, ktoré sú priložené k zariadeniu.

USCHOVAJTE SI TENTO NÁVOD**Opozorilo POMEMBNI VARNOSTNI NAPOTKI**

Ta opozorilni simbol pomeni nevarnost. Nahajate se v situaciji, kjer lahko pride do telesnih poškodb. Preden pričnete z delom na napravi, se morate zavedati nevarnosti udara električnega toka, ter tudi poznati preventivne ukrepe za preprečevanje takšnih nevarnosti. Uporabite obrazložitevno številko na koncu posameznega opozorila, da najdete opis nevarnosti v priloženem varnostnem priročniku.

SHRANITE TE NAPOTKE!**警告****重要安全性指示**

此警告符號代表危險，表示可能造成人身傷害。使用任何設備前，請留心電路相關危險，並熟悉避免意外的標準作法。您可以使用每項警告後的聲明編號，查詢本裝置隨附之安全性警告譯文中的翻譯。請妥善保留此指示

Related Documentation

Documentation for the Cisco Nexus 600 Series switches is available at the following URL:

<http://www.cisco.com/c/en/us/support/switches/nexus-6000-series-switches/tsd-products-support-series-home.html>

Obtaining Documentation and Submitting a Service Request

For information on obtaining documentation, submitting a service request, and gathering additional information, see the monthly *What's New in Cisco Product Documentation*, which also lists all new and revised Cisco technical documentation, at:

<http://www.cisco.com/c/en/us/td/docs/general/whatsnew/whatsnew.html>

Subscribe to the *What's New in Cisco Product Documentation* as a Really Simple Syndication (RSS) feed and set content to be delivered directly to your desktop using a reader application. The RSS feeds are a free service and Cisco currently supports RSS Version 2.0.



CHAPTER 1

Overview

This chapter provides an overview of the Cisco Nexus 6000 Series switches. The overview includes information on the expansion modules, power supplies, and fan modules that you can include with the switches. This chapter describes the Cisco Nexus 6000 Series switches and includes the following sections:

- [Cisco Nexus 6001 Switch, page 1-1](#)
- [Cisco Nexus 6004 Switch, page 1-6](#)

Cisco Nexus 6001 Switch

This section describes the Cisco Nexus 6001 switches (N6K-C6001-64P and N6K-C6001-64T) and their components. This section includes the following topics:

- [Features, page 1-1](#)
- [Chassis, page 1-2](#)
- [Power Supply, page 1-3](#)
- [Fan Modules, page 1-4](#)
- [Transceivers, page 1-4](#)

Features

The Cisco Nexus 6001 Switch is a compact 1RU (1 Rack Unit), high-performance, low-latency 10/40-Gigabit Ethernet and Fibre Channel over Ethernet (FCoE) switch. It runs the industry-leading Cisco NX-OS Software operating system, providing features and capabilities that are widely deployed. There are two versions of the device, a Small Form-Factor Pluggable (SFP+) version (N6K-C6001-64P) and a 10G BASE-T (N6K-C6001-64T) version.

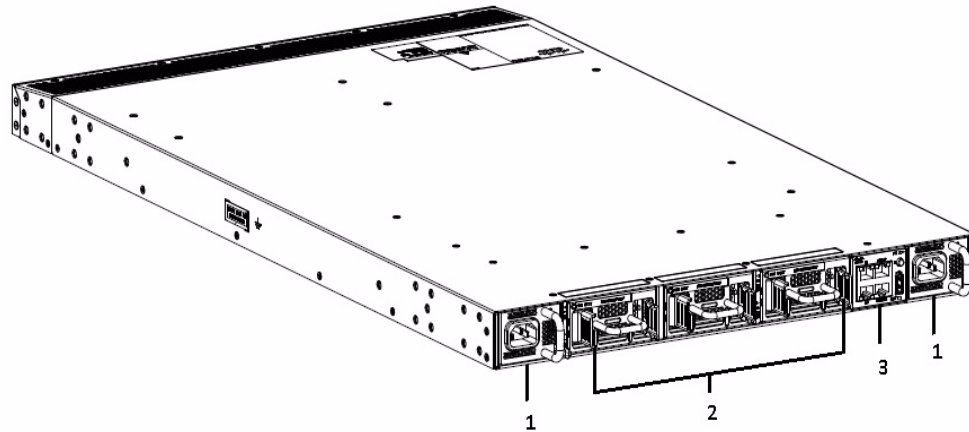
The Cisco Nexus 6001 switch has the following features:

- 48 fixed SFP+ ports on the back of the switch.
- Four Quad Small Form-Factor Pluggable (QSFP+) ports on the back of the switch.
- Two slots on the front of the switch for hot swap-capable power supplies, which provide front-to-back and back-to-front airflow for cooling.
- Three slots on the front of the switch for hot swap-capable fan modules.
- A management and console interface on the front of the switch.

Chassis

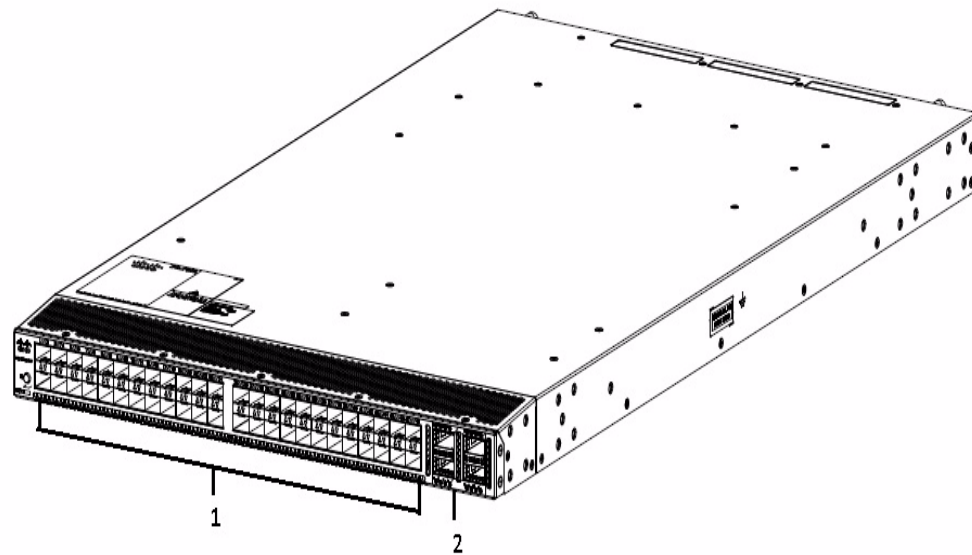
The Cisco Nexus 6001 switch chassis is 1 RU, 1.75 inches (4.4 cm) tall, 17.3 inches (43.9 cm) wide, and 30 inches (76.2 cm) deep. The front of the switch is shown in [Figure 1-1](#).

Figure 1-1 Front View of the Cisco Nexus 6001 switch



1	Two power supplies
2	Three fan modules
3	Management and Console interface

The rear of the Cisco Nexus 6001 switch chassis, is shown in [Figure 1-2](#).

Figure 1-2 Rear View of the Cisco Nexus 6001 switch

1	48 fixed SFP+ ports	2	4 QSFP+ ports
----------	---------------------	----------	---------------

Power Supply

The Cisco Nexus 6001 switch uses a front-end power supply. The chassis has slots for two redundant power supplies. Power Supply options need to be configured with the base chassis. It needs minimum of one power supply to operate. OIR is supported on the power supplies and the power supplies are hot swappable. The Cisco Nexus 6001 supports front-to-back (port-side exhaust) and back-to-front airflow (port-side intake). [Table 1-1](#) lists the power supplies that you can order with a Cisco Nexus 6001 switch.

Table 1-1 Power Supplies for the Cisco Nexus 6001 switch

Part Number	Power Supply
N55K-PAC-1100W	Cisco Nexus 6001 PSU module, 100-240VAC 1100W, Front-to-Back (Port Side Exhaust) Airflow
N55K-PAC-1100W-B	Cisco Nexus 6001 PSU module, 100-240VAC 1100W, Back-to-Front (Port Side Intake) Airflow
N55-PDC-1100W	Cisco Nexus 1100 Watt DC front-to-back power supply
NXA-PHV-1100W	Cisco Nexus 5500/6000 PSU port side exhaust airflow module, AC/DC, 1100W
NXA-PHV-1100W-B	Cisco Nexus 5500/6000 PSU port side intake airflow module, AC/DC, 1100W

**Note**

The 1100 W, AC/DC, back-to-front, power supply (PID: N55-PAC-1100W-B) is not supported on the N6K-C6001-64T.

**Note**

The Cisco Nexus 6001 AC power supplies support both 110 and 220-volt (V) inputs.

**Caution**

Never leave a power supply slot empty. If you remove a power supply, replace it with another one. If you do not have a replacement power supply, leave the non functioning one in place until you can replace it.

Fan Modules

The Cisco Nexus 6001 has three individual fan modules supporting four fans per module. Fan modules are hot-swappable. Fan modules operate in a 2+1 redundancy mode. If a fan fails, the unit can run indefinitely with only 3 operational fans. Fan options need to be configured with the base chassis. The Cisco Nexus 6001 switch supports front-to-back and back-to-front airflow. OIR is supported on the fan tray. [Table 1-2](#) lists the fans that you can order with a Cisco Nexus 6001 switch.

Table 1-2 Fan Modules for the Cisco Nexus 6001 switch

Part Number	Power Supply
N6K-C6001-FAN-F=	Cisco Nexus 6001 Fan Module, Front-to-Back (Port Side Exhaust) Airflow, spare
N6K-C6001-FAN-B=	Cisco Nexus 6001 PSU module, 100-240VAC 1100W, Back-to-Front (Port Side Intake) Airflow, Spare

**Caution**

You must order all fan modules and power supplies in the same chassis so that they have the same direction of airflow with coolant air entering the chassis from the cold aisle and exhausting to the hot aisle.

Transceivers

The Cisco Nexus 6001 supports a wide variety of 1, 10, and 40 Gigabit Ethernet connectivity options. This section includes the following topics:

- [1 and 10 Gigabit Ethernet SFP+ Transceiver Support Matrix, page 1-5](#)
- [40 Gigabit Ethernet QSFP+ Transceiver Support Matrix, page 1-5](#)

1 and 10 Gigabit Ethernet SFP+ Transceiver Support Matrix

Cisco SFP	Description
FET-10G	10-Gbps SFP+ module for Cisco Nexus 2000 Series to Cisco Nexus 5000 Series connectivity
Cisco SFP-10G-SR	10GBASE-SR SFP+ module (multimode fiber [MMF])
Cisco SFP-10G-LR	10GBASE-LR SFP+ module (single-mode fiber [SMF])
Cisco SFP-10G-ER	10GBASE-ER-SFP+ module (SMF)
Cisco SFP-H10GB-CU1M	10GBASE-CU SFP+ cable 1m (Twinax cable)
Cisco SFP-H10GB-CU3M	10GBASE-CU SFP+ cable 3m (Twinax cable)
Cisco SFP-H10GB-CU5M	10GBASE-CU SFP+ cable 5m (Twinax cable)
Cisco SFP-H10GB-ACU7M	10GBASE-CU SFP+ cable 7m (active Twinax cable)
Cisco SFP-H10GB-ACU10M	10GBASE-CU SFP+ cable 10m (active Twinax cable)
Cisco GLC-T	1000BASE-T SFP
GLC-ZX-SM	1000BASE-ZX SFP transceiver module for SMF, 1550-nm wavelength, dual LC/PC connector
Cisco GLC-SX-MM	Gigabit Ethernet SFP, LC connector SX transceiver (MMF)
Cisco GLC-SX-MMD	Gigabit Ethernet SFP, LC connector SX transceiver (MMF), extended temperature range and digital optical monitoring (DOM)
Cisco GLC-LH-SM	Gigabit Ethernet SFP, LC connector LX/LH transceiver (SMF)
Cisco GLC-LH-SMD	Gigabit Ethernet SFP, LC connector LX/LH transceiver (SMF), extended temperature range and digital optical monitoring (DOM)
Cisco SFP-GE-T	1000BASE-T SFP, extended temperature range
Cisco SFP-GE-S	Gigabit Ethernet SFP, LC connector SX transceiver (MMF), extended temperature range and digital optical monitoring (DOM)
Cisco SFP-GE-L	Gigabit Ethernet SFP, LC connector LX/LH transceiver (SMF), extended temperature range and DOM

40 Gigabit Ethernet QSFP+ Transceiver Support Matrix

Cisco SFP	Description
QSFP-40G-SR4	40GBASE-SR4 QSFP module, (multi-mode fiber, MMF at 100m)
QSFP-40G-CSR4	40GBASE Extended CSR4 QSFP module, (multi-mode fiber, MMF at 300m)
QSFP-40G-LR4	40G Base Extended LR4 QSFP module, LC connector 10Km
QSFP-4x10G-AC7M	Cisco 40GBASE-CR4 QSFP+ to 4 10GBASE-CU SFP+ direct-attach breakout cable, 7-meter, active

Cisco SFP	Description
QSFP-4x10G-AC10M	Cisco 40GBASE-CR4 QSFP+ to 4 10GBASE-CU SFP+ direct-attach breakout cable, 10-meter, active
QSFP-H40G-CU1M	Cisco 40GBASE-CR4 QSFP+ direct-attach copper cable, 1-meter, passive
QSFP-H40G-CU3M	Cisco 40GBASE-CR4 QSFP+ direct-attach copper cable, 3-meter, passive
QSFP-H40G-CU5M	Cisco 40GBASE-CR4 QSFP+ direct-attach copper cable, 5-meter, passive
QSFP-H40G-ACU7M	Cisco 40GBASE-CR4 QSFP+ direct-attach copper cable, 7-meter, active
QSFP-H40G-ACU10M	Cisco 40GBASE-CR4 QSFP+ direct-attach copper cable, 10-meter, active

**Note**

The platform supports a Twinax copper cabling solution that connects to standard QSFP connectors for in-rack use, and optical cabling for longer cable runs:

For in-rack or adjacent-rack cabling, the Cisco Nexus 6001 supports QSFP+ direct-attach 40 Gigabit Ethernet copper cables, an innovative solution that integrates transceivers with Twinax cables into an energy-efficient, low-cost, and low-latency solution. QSFP+ direct-attach 40 Gigabit Twinax copper cables use only 1.5 watt (W) of power per transceiver and introduce approximately 0.1 microsecond of latency per link.

For longer cable runs, the Cisco Nexus 6001 supports multimode, short-reach optical QSFP+ transceivers. These optical transceivers use approximately 1.5W per transceiver and have a latency of approximately 0.1 microsecond.

Cisco Nexus 6004 Switch

This section describes the Cisco Nexus 6004 Switches (N6K-C6004-96Q and N6004-B-24Q) and their components. This section includes the following topics:

- [Features, page 1-6](#)
- [Chassis, page 1-7](#)
- [Expansion Modules, page 1-9](#)
- [Ports, page 1-11](#)
- [Power Supply, page 1-12](#)
- [Fan Module, page 1-13](#)
- [Transceivers, page 1-15](#)

Features

The Cisco Nexus 6004 offers the industry's highest 10 and 40 Gigabit Ethernet and Fibre Channel over Ethernet (FCoE) port density in a compact energy-efficient form factor, with integrated Layer 2 and Layer 3 features at wire speed and low latency of approximately 1 microsecond for any packet size. With a choice of front-to-back or back-to-front airflow options, the switch is designed for a broad range of traditional data center and large-scale virtualized cloud deployments. The Cisco Nexus 6004 switches are 4RU switches. The N6K-C6004-96Q is a 96-port, 10/40-Gigabit Ethernet and Fibre Channel over Ethernet (FCoE) switch and has the following features:

- 48 fixed ports on the back of the switch

- Four slots on the back of the switch for expansion modules.
- Six slots on the front of the switch for hot swap-capable power supplies, which provide front-to-back and back-to-front airflow for cooling
- Four slots on the front of the switch for hot swap-capable fan modules.
- One console management port on the front of the switch.
- One USB port on the front of the switch.

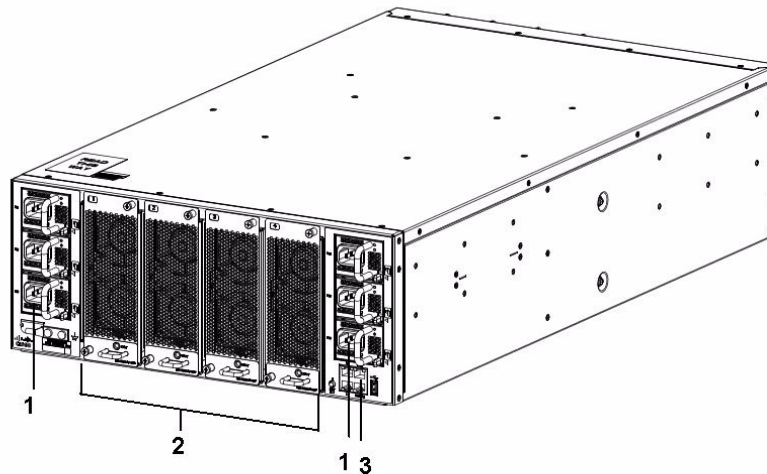
The Cisco Nexus 6004 Extensible Fixed (EF) version (N6004-B-24Q) offers eight line-card expansion module (LEM) slots to support a total of 96 ports of 40 Gbps throughput in a fully populated system. It provides low-cost entry point for small-scale deployments. Each LEM supports 12 ports of 40 Gigabit Ethernet in a QSFP form factor. Each 40 Gigabit Ethernet port can also be split into four line-rate 10 Gigabit Ethernet ports using QSFP breakout cables. this Cisco Nexus 6004 chassis along with the LEMs offers incredible flexibility for scaling deployments, making it the only fully extensible fixed 10 and 40 Gigabit Ethernet platform in the industry.

Chassis

The Cisco Nexus 6004 switch chassis is 4 RU, 6.97 inches (17.7 cm) tall, 17.3 inches (43.9 cm) wide, and 30 inches (76.2 cm) deep.

It is designed to be mounted in a standard 19-inch wide rack. The front of the switch, shown in [Figure 1-3](#), has a console management port and USB port, six power supplies, and four fan modules.

Figure 1-3 Front View of the Cisco Nexus 6004 switch



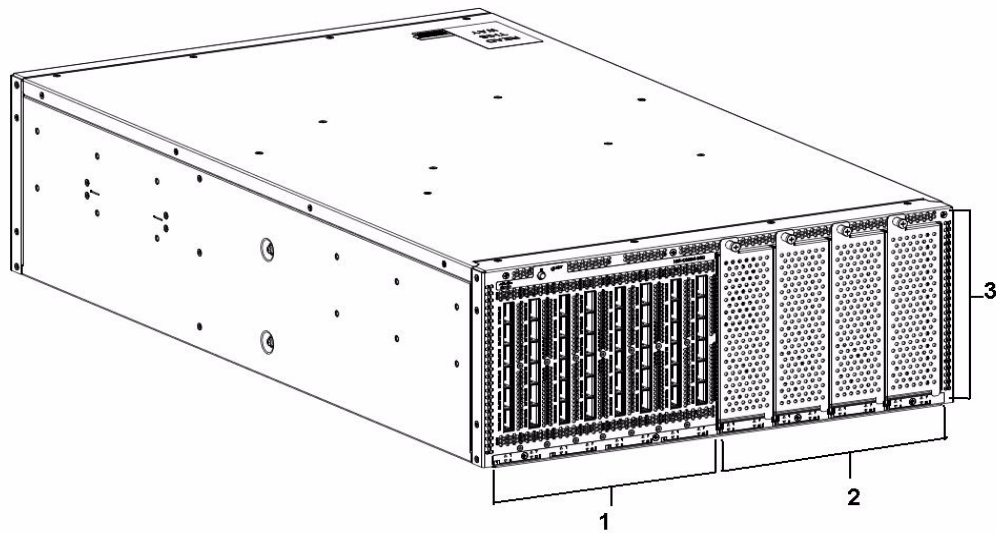
1	Six power supplies with 3+3 grid redundancy
2	Four fan module with 3+1 redundancy
3	Console Mgmt0 port and USB port

**Note**

The fans and power supplies need to be configured.

The rear of the Cisco Nexus 6004 switch (N6K-C6004-96Q) chassis, shown in [Figure 1-4](#), has 48 fixed 10/40-Gigabit Ethernet ports, and four slots for expansion modules.

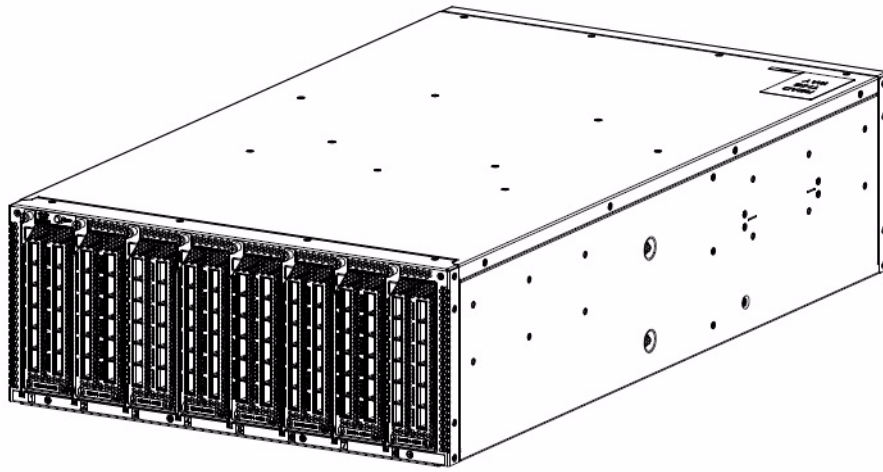
Figure 1-4 Rear View of the Cisco Nexus 6004 Switch (N6K-C6004-96Q)



1	Fixed ports	3	4RU chassis
2	Four expansion modules		

The rear of the Cisco Nexus 6004 switch (N6004-B-24Q) chassis, shown in [Figure 1-5](#), has 8 removable line-card expansion module (LEM) slots to support a total of 96 ports of 40 Gbps.

Figure 1-5 Rear View of the Cisco Nexus 6004 Switch (N6004-B-24Q)



Expansion Modules

Expansion modules allow the Cisco Nexus 6004 switch to be configured as a cost-effective 10/40/100-Gigabit Ethernet switch and as an I/O consolidation platform with native Fibre Channel connectivity.

The Cisco Nexus 6004EF switch has eight slots, and the Cisco Nexus 6004 switch has four slots, that can be used for the following expansion modules:

- N6004-M12Q: Hot swappable linecard expansion module (LEM) that provides 12x 40-Gigabit Ethernet/FCoE ports.
- N6004X-M20UP: Hot swappable LEM that provides 20x 1/10-Gigabit Ethernet/FCoE SFP+ and 8/4/2-Gigabit Fibre Channel ports for the Cisco Nexus 6004EF switch.
- N5696-M4C: Hot swappable LEM that provides 4x 100-Gigabit Ethernet ports for the Cisco Nexus 6004EF switch.

You can hot swap the expansion modules during operations.



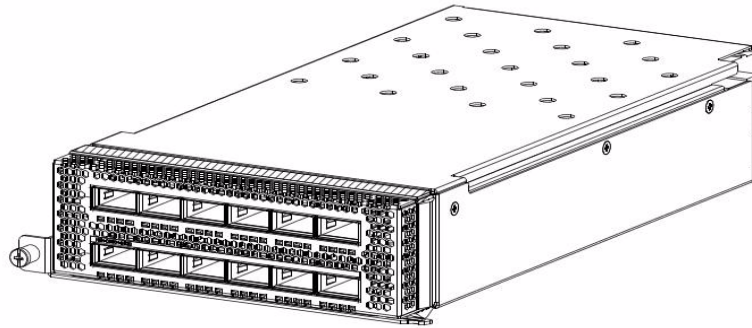
Caution

You must power off the module before removing the module from the system for hot swap.

N6004-M12Q

The Cisco Nexus 6004-M12Q expansion module provides up to twelve 40 Gigabit Ethernet and FCoE ports for the Cisco Nexus 6004EF switch.

[Figure 1-6](#) shows the N6004-M12Q expansion module.

Figure 1-6 12 Port 40 Gbps Linecard Expansion Module**Note**

The Cisco Nexus N6004-M12Q LEM is supported from Cisco NX-OS Release 7.0(4)N1(1).

N6004X-M20UP

The Unified Port LEM (N6004X-M20UP) for the Cisco Nexus 6004EF switch provides up to twenty 1/10 Gigabit Ethernet and FCoE ports using the SFP+ interface or up to twenty ports of native Fibre Channel connectivity using 8/4/2-Gbps SFP+ and SFP interfaces. The use of 1/10 Gigabit Ethernet or 8/4/2-Gbps Fibre Channel on a port is mutually exclusive but can be selected for any of the twenty physical ports per module.

**Note**

The Cisco Nexus N6004X-M20UP LEM is supported from Cisco NX-OS Release 7.0(1)N1(1).

N5696-M4C

The Cisco Nexus 5696-M4C LEM is a 4-port 100G LEM that provides 100 Gigabit Ethernet ports for the Cisco Nexus 6004EF switch. Each 5696-M4C offers 4 CXP optical module connections, which provide a total bandwidth of 400Gbps. The port interface supports CXP optical PMD modules such as CXP-100G-SR10 and CXP-100G-SR12. You can configure a total of 8 100G LEM modules in a Cisco Nexus 6004EF switch to provide a total of 32 CXP 100 Gigabit Ethernet connections.

Figure 1-7 4 Port 100Gbps Linecard Expansion Module



Note

The Cisco Nexus 5696-M4C LEM requires a minimum of 4 operating power supplies when installed.



Note

The Cisco Nexus 5696-M4C LEM is supported from Cisco NX-OS Release 7.1(0)N1(1b) and BIOS version 2.8.0 (included in the Cisco NX-OS release).

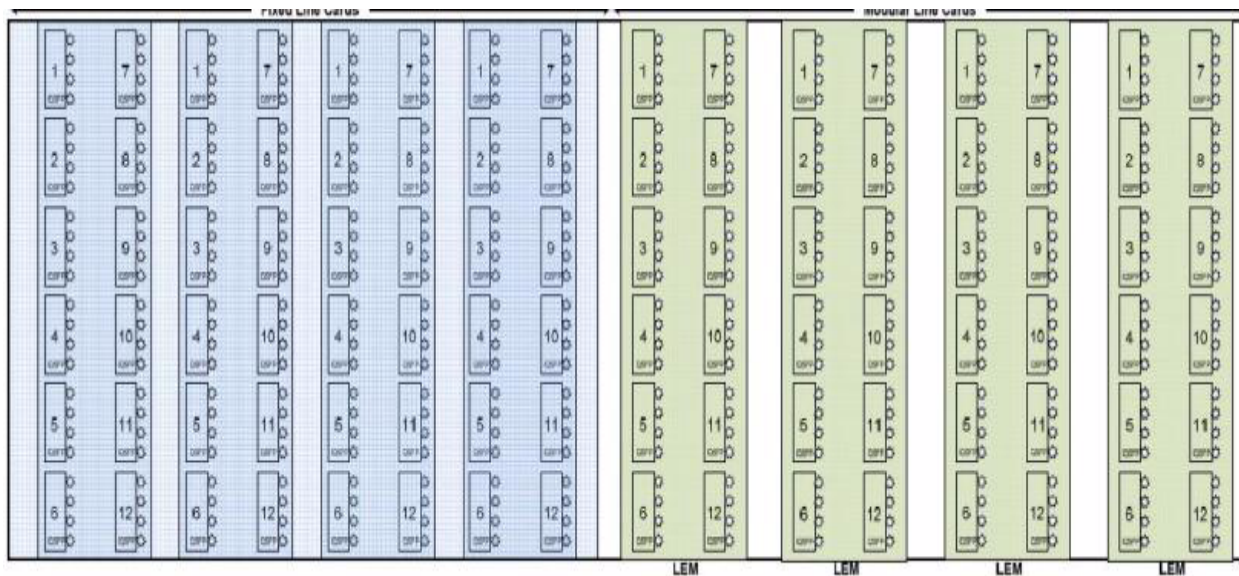
Ports

All the individual ports on the Cisco Nexus 6004 switch are numbered and groups of ports are numbered based on their function. Depending on how it is configured, there are 96 ports on the Cisco Nexus 6004 switch. The ports are numbered from top-to-bottom and from left-to-right. The fixed ports are grouped together and the modular ports are grouped together.

For the M4C LEM, port 1 and 2 are on the left and port 3 and 4 are on the right.

[Figure 1-8](#) shows how ports are numbered and grouped by function.

Figure 1-8 Port Numbering of the Cisco Nexus 6004 switch



Power Supply

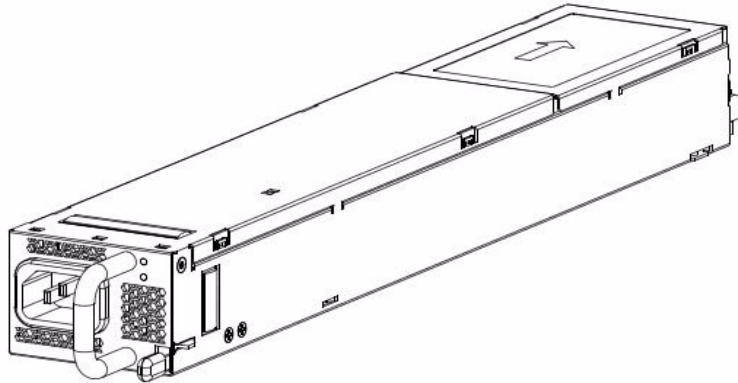
The Cisco Nexus 6004 switch uses a front-end power supply. The chassis has slots for six power supplies. [Table 1-3](#) lists the power supplies that you can order with the Cisco Nexus 6004 N6K-C6004-96Q and N6004-B-24Q switches.

Table 1-3 Power Supplies for the Cisco Nexus 6004 switches

Part Number	Power Supply
N55-PAC-1100W	Cisco Nexus 5500/6000 PSU module, (port side exhaust airflow) 100-240VAC 1100W
N55-PAC-1100W=	Cisco Nexus 5500/6000 PSU module, (port side exhaust airflow) 100-240VAC 1100W, Spare
N55-PAC-1100W-B	Cisco Nexus 5500/6000 PSU module, port side intake (back to front) airflow 100-240VAC 1100W
N55-PAC-1100W-B=	Cisco Nexus 5500/6000 PSU module, port side intake (back to front) airflow 100-240VAC 1100W, Spare
N55-PDC-1100W	Cisco Nexus 5500/6000 PSU module, DC 1100W
N55-PDC-1100W=	Cisco Nexus 5500/6000 PSU module, DC 1100W, Spare

[Figure 1-9](#) shows a Cisco Nexus 6004 Power Supply. You can see the Cisco Nexus 5000 Series Hardware Installation Guide for details about the power supplies.

Figure 1-9 Cisco Nexus 6004 Power Supply

**Note**

Never leave a power supply slot empty. If you remove a power supply, replace it with another one. If you do not have a replacement power supply, leave the non functioning one in place until you can replace it.

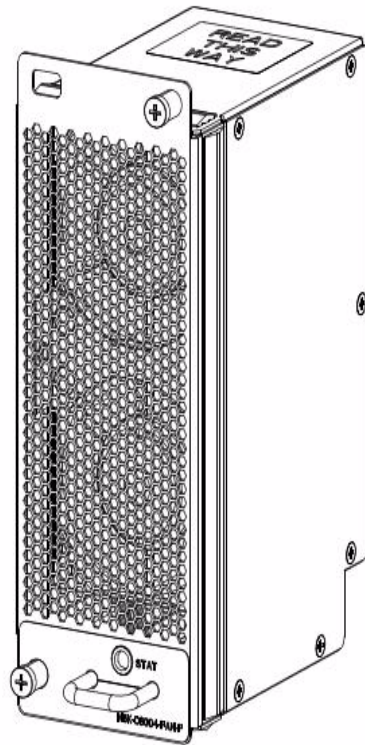
Fan Module

The Cisco Nexus 6004 switch has four fan modules. Although the switch can function when a fan stops functioning within a fan module, if a whole fan module stops functioning, you must replace the fan module. The Cisco Nexus 6004 switch supports the front to back airflow (N6K-C6004-FAN-F) and back to front airflow (N6K-C6004-FAN-B).

**Note**

On a Cisco Nexus 6004 Extensible Fixed Switch, if you upgrade from an earlier release to Cisco NX-OS Release 7.1(4)N1(1) or later, the fan speed on all fans will increase and it will operate at 100%. This is according to the design and will not have any longevity issues.

Figure 1-10 shows a fan module.

Figure 1-10 Cisco Nexus 6004 Fan Module

The bicolor status LED indicates fan tray health. Green indicates normal operation, while amber indicates a fan failure. For more information about LEDs, see [Table D-1](#).

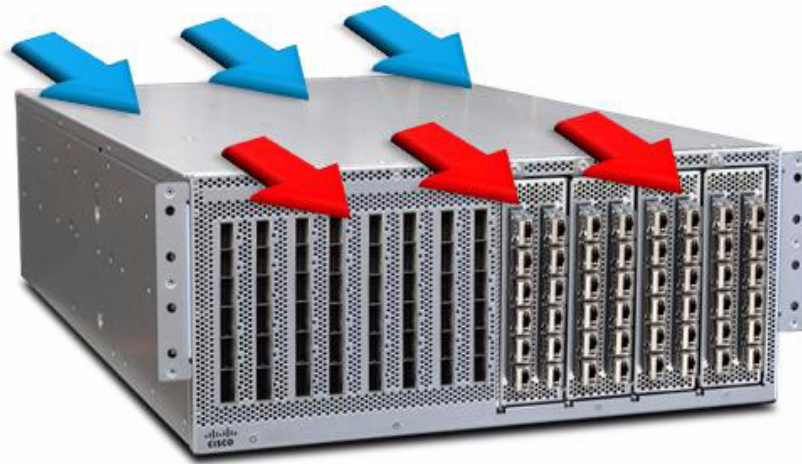
**Caution**

You must order all fan modules and power supplies in the same chassis so that they have the same direction of airflow with coolant air entering the chassis from the cold aisle and exhausting to the hot aisle.

Airflow

Power supplies and fan modules should be selected depending on the desired air flow direction.

[Figure 1-11](#) shows a fan module

Figure 1-11 **Airflow**

Transceivers

The Cisco Nexus 6004 series switch supports a wide variety of 10 and 40 Gigabit Ethernet connectivity options using Cisco 40GBASE QSFP and breakout cable options.

This section includes the following topics:

- [Transceiver Support Matrix, page 1-15](#)

Transceiver Support Matrix

The Cisco Nexus 6004 switch also supports the following QSFP transceivers:

Cisco SFP	Description
QSFP-40G-SR4	40GBASE-SR4 QSFP module, (multimode fiber [MMF] at 100m)
QSFP-40G-CSR4	40GBASE Extended CSR4 QSFP module, (MMF at 300m)
QSFP-4x10G-AC7M	Cisco 40GBASE-CR4 QSFP+ to 4 10GBASE-CU SFP+ direct-attach breakout cable, 7m, active
QSFP-4x10G-AC10M	Cisco 40GBASE-CR4 QSFP+ to 4 10GBASE-CU SFP+ direct-attach breakout cable, 10m, active
QSFP-H40G-CU1M	Cisco 40GBASE-CR4 QSFP+ direct-attach copper cable, 1m, passive
QSFP-H40G-CU3M	Cisco 40GBASE-CR4 QSFP+ direct-attach copper cable, 3m, passive
QSFP-H40G-CU5M	Cisco 40GBASE-CR4 QSFP+ direct-attach copper cable, 5m, passive
QSFP-H40G-ACU7M	Cisco 40GBASE-CR4 QSFP+ direct-attach copper cable, 7m, active
QSFP-H40G-ACU10M	Cisco 40GBASE-CR4 QSFP+ direct-attach copper cable, 10m, active

**Note**

For in-rack or adjacent-rack cabling, the Cisco Nexus 6004 platform supports QSFP+ direct-attach 40 Gigabit Ethernet copper cables, an innovative solution that integrates transceivers with Twinax cables into an energy-efficient, low-cost, and low-latency solution. QSFP+ direct-attach 40 Gigabit Ethernet Twinax copper cables use only 1.5 watts (W) of power per transceiver and introduce less than 0.1 microsecond of latency per link. For longer cable runs, the Cisco Nexus 6004 platform supports multimode, short-reach optical QSFP transceivers. These optical transceivers use approximately 1.5W per transceiver and have a latency of less than 0.1 microsecond.



CHAPTER 2

Installing the Cisco Nexus 6000 Series Switches

This chapter describes how to install the Cisco Nexus 6000 switch. This chapter includes the following sections:

- [Preparing for Installation, page 2-2](#)
- [Installing the Switch, page 2-5](#)
- [Grounding the Switch, page 2-7](#)
- [Starting the Switch, page 2-12](#)
- [Installing a Reverse Airflow System for the Cisco Nexus 6004 Switch, page 2-14](#)
- [Removing Fan Shutters, page 2-15](#)



Note

Before you install, operate, or service the system, see the *Regulatory, Compliance, and Safety Information for the Cisco Nexus 6000 Series, Cisco Nexus 5000 Series, Cisco Nexus 3000 Series, and Cisco Nexus 2000 Series* for important safety information.



Warning

IMPORTANT SAFETY INSTRUCTIONS

This warning symbol means danger. You are in a situation that could cause bodily injury. Before you work on any equipment, be aware of the hazards involved with electrical circuitry and be familiar with standard practices for preventing accidents. Use the statement number provided at the end of each warning to locate its translation in the translated safety warnings that accompanied this device.
Statement 1071

SAVE THESE INSTRUCTIONS



Warning

This unit is intended for installation in restricted access areas. A restricted access area can be accessed only through the use of a special tool, lock and key, or other means of security.
Statement 1017



Warning

Only trained and qualified personnel must be allowed to install, replace, or service this equipment.
Statement 1030

**Note**

Each new switch requires a license. For information on licensing, see the *Cisco NX-OS Licensing Guide*.

Preparing for Installation

This section describes how to prepare the Cisco Nexus 6000 switch for installation. This section includes the following topics:

- [Installation Options with Racks and Cabinets, page 2-2](#)
- [Airflow Direction, page 2-2](#)
- [Chassis Weight, page 2-2](#)
- [Installation Guidelines, page 2-3](#)
- [Required Equipment, page 2-4](#)
- [Unpacking and Inspecting the Switch, page 2-4](#)

Installation Options with Racks and Cabinets

The Cisco Nexus 6000 switch can be installed in the following types of racks using a rack-mount kit shipped with the switch:

- Open EIA rack
- Perforated EIA cabinet

To enable you to easily mount your switch in any qualifying rack, you can attach the rack-mount brackets to accommodate racks of different depths. For instructions on how to use a rack-mount kit, see the “[Installing the Switch](#)” section on page 2-5.

Airflow Direction

The airflow through the fan trays and power supplies on the Cisco Nexus 6000 switch is either from front to back or from back to front, depending on how the modules were ordered. To ensure proper airflow, you must make sure that when you install the switch its air intake is positioned in a cold aisle and the air exhaust is positioned in a hot aisle for your data center.

AI: Add the terms port side intake (back to front) and port side exhaust (front to back)

Chassis Weight

When lifting the switch chassis, follow these guidelines:

- Disconnect all power and external cables before lifting the switch.
- Have two people lift the switch. The Cisco Nexus 6004 with three 1100W power supplies, four expansion modules, and four fan modules weighs 122 lb. The Cisco Nexus 6004 with three 1100W power supplies and four fan modules weighs 100 lb.
- Ensure that your footing is solid and the weight of the switch is evenly distributed between your feet.

- Lift the switch slowly, keeping your back straight. Lift with your legs, not with your back. Bend at the knees, not at the waist.

Installation Guidelines

When installing the Cisco Nexus 6000 switch, follow these guidelines:

- Record the information listed in [Appendix G, “Site Planning and Maintenance Records,”](#) as you install and configure the switch.
- Ensure that there is adequate space around the switch to allow for servicing the switch and for adequate airflow ([Appendix B, “Technical Specifications,”](#) lists the service and airflow requirements).
- Ensure that the air-conditioning meets the heat dissipation requirements listed in [Appendix B, “Technical Specifications.”](#)
- Ensure that the cabinet or rack meets the requirements listed in [Appendix A, “Cabinet and Rack Installation.”](#)



Note Jumper power cords are available for use in a cabinet. See the [“Jumper Power Cord”](#) section on [page C-8](#).

- Ensure that the chassis can be adequately grounded. If the switch is not mounted in a grounded rack, we recommend connecting both the system ground on the chassis and the power supply ground directly to an earth ground.
- Ensure that the site power meets the power requirements listed in [Appendix B, “Technical Specifications.”](#) If available, you can use an uninterruptible power supply (UPS) to protect against power failures.



Caution Avoid UPS types that use ferroresonant technology. These UPS types can become unstable with systems such as the Cisco Nexus 6000 switch, which can have substantial current draw fluctuations because of fluctuating data traffic patterns.

- Ensure that circuits are sized according to local and national codes. For North America, the power supply requires a 15-A or 20-A circuit.



Caution To prevent loss of input power, ensure the total maximum loads on the circuits supplying power to the switch are within the current ratings for the wiring and breakers.

- Ensure that all fan trays and power supplies have the same airflow direction.
- Use the following screw torques when installing the switch:
 - Captive screws: 4 in-lb (0.45 N·m)
 - M3 screws: 4 in-lb (0.45 N·m)
 - M4 screws: 12 in-lb (1.36 N·m)
 - 10-32 screws: 20 in-lb (2.26 N·m)
 - 12-24 screws: 30 in-lb (3.39 N·m)

Required Equipment

Before beginning the installation, ensure that you have the following items available:

- Four 12-24 or 10-32 screws for attaching slider rails to the rack
- Number 1 and number 2 Phillips screwdrivers with torque capability
- 3/16-inch flat-blade screwdriver
- Tape measure and level
- ESD wrist strap or other grounding device
- Antistatic mat or antistatic foam

The following additional items (not found in the accessory kit) are required to ground the chassis:

- Grounding cable (6 AWG recommended), sized according to local and national installation requirements; the required length depends on the proximity of the switch to proper grounding facilities
- Crimping tool large enough to accommodate the girth of the lug
- Wire-stripping tool

Unpacking and Inspecting the Switch



Caution

When handling switch components, wear an ESD strap and handle modules by their handles and carrier edges only. An ESD socket is provided on the chassis. For the ESD socket to be effective, the chassis must be grounded through the power cable, the chassis ground, or the metal-to-metal contact with a grounded rack.



Tip

Keep the shipping container in case the chassis requires shipping in the future.



Note

The switch is thoroughly inspected before shipment. If any damage occurred during transportation or any items are missing, contact your customer service representative immediately.

To inspect the shipment, follow these steps:

Step 1 Compare the shipment to the equipment list provided by your customer service representative and verify that you have received all items, including the following:

- Grounding lug kit
- Rack-mount kit
- ESD wrist strap
- Cables with connectors
- Any optional items ordered

Step 2 Check for damage and report any discrepancies or damage to your customer service representative. Have the following information ready:

- Invoice number of shipper (see packing slip)
- Model and serial number of the damaged unit
- Description of damage
- Effect of damage on the installation

Installing the Switch

This section includes the following topics:

- [Installing a Cisco Nexus 6000 switch, page 2-5](#)

Installing a Cisco Nexus 6000 switch

This section describes how to use the rack-mount kit provided with the switch to install the Cisco Nexus 6000 switch into a cabinet or rack that meets the requirements described in [Appendix A, “Cabinet and Rack Installation.”](#)



Caution

If the rack is on wheels, ensure that the brakes are engaged or that the rack is otherwise stabilized.

The table below lists the items contained in the rack-mount kit provided with the Cisco Nexus 6004 switch.

Table 2-1 Cisco Nexus 6004 switch Rack-Mount Kit

Quantity	Part Description
4	Rack-mount brackets
24	M4 x 0.7 x 8-mm Phillips flat-head screws
4	Rack-mount guides
4	Slider rails (22 inch minimum to a 36 inch maximum)



Note

You must supply the 24 screws required to mount the rack brackets and slider rails to the rack. The rack-mount kit does not provide these screws.

To install the switch in a rack or cabinet using the rack-mount kit provided with the switch, follow these steps:

Step 1

Install the front rack-mount brackets on the chassis as follows:

- a. Position a front rack-mount bracket on the side of the chassis with its four holes aligned to four of the six screw holes on the front side of the chassis, and then use four M4 screws to attach the bracket to the chassis.



Note You can align any four of the holes in the front rack-mount bracket to four of the six screw holes in the chassis. The holes that you use depend on the requirements of your rack.

- b. Repeat Step 1a with the other front rack-mount bracket on the other side of the switch.

Step 2 Install the rear rack-mount guides on the chassis as follows:

- a. Position a rear rack-mount bracket on the side of the chassis with its four holes aligned to four of the six screw holes on the side of the chassis, and then use four M4 screws to attach the bracket to the chassis.
- b. Repeat Step 2a with the other rear rack-mount bracket on the other side of the switch.

Step 3 Install the slider rails to the rack as follows:

- a. Position the slider rails at the desired level on the back side of the rack and use two 12-24 screws or two 10-32 screws, depending on the rack thread type, to attach the rails to the rack.



Note For racks with square holes, you might need to position a 12-24 cage nut behind each mounting hole in a slider rail before using a 12-24 screw.

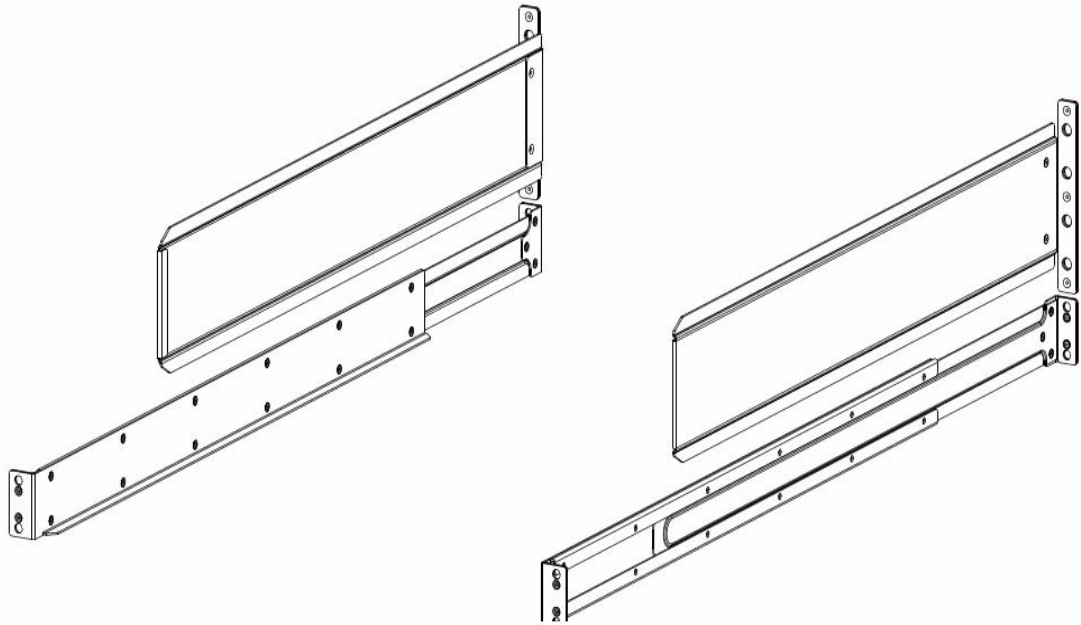
- b. Repeat with the other slider rail on the other side of the rack.
- c. Use the tape measure and level to verify that the rails are at the same height and horizontal.

Step 4 Insert the switch into the rack and attach it as follows:

- a. Holding the switch with both hands, position the back of the switch between the front posts of the rack.
- b. Align the two rear rack-mount guides on either side of the switch with the slider rails installed in the rack. Slide the rack-mount guides onto the slider rails, and then gently slide the switch all the way into the rack. The Cisco Nexus 6004 chassis slider rails are shown in [Figure 2-1](#).



Note If the switch does not slide easily, try realigning the rack-mount guides on the slider rails.

Figure 2-1 *Slider Rails*

- c. Holding the chassis level, insert two screws (12-24 or 10-32, depending on the rack type) through the cage nuts and the holes in one of the front rack-mount brackets and into the threaded holes in the rack-mounting rail.
- d. Repeat for the other front rack-mount bracket on the other side of the switch.

Grounding the Switch

This section describes the need for system grounding for all of the Cisco Nexus 6000 switch and explains how to prevent damage from electrostatic discharge.

This section includes the following topics:

- [Proper Grounding Practices, page 2-7](#)
- [Preventing Electrostatic Discharge Damage, page 2-9](#)
- [Establishing the System Ground, page 2-10](#)
- [Required Tools and Equipment, page 2-11](#)
- [Grounding the Cisco Nexus 6000 Series Chassis, page 2-11](#)

Proper Grounding Practices

Grounding is one of the most important parts of equipment installation. Proper grounding practices ensure that the buildings and the installed equipment within them have low-impedance connections and low-voltage differentials between chassis. When you properly ground systems during installation, you reduce or prevent shock hazards, equipment damage due to transients, and data corruption. [Table 2-2](#) lists some general grounding practice guidelines.

Table 2-2 Proper Grounding Guidelines

Environment	Electromagnetic Noise Severity Level	Grounding Recommendations
Commercial building is subjected to direct lightning strikes. For example, some places in the United States, such as Florida, are subject to more lightning strikes than other areas.	High	All lightning protection devices must be installed in strict accordance with manufacturer recommendations. Conductors carrying lightning current should be spaced away from power and data lines in accordance with applicable recommendations and codes. Best grounding recommendations must be closely followed.
Commercial building is located in an area where lightning storms frequently occur but is not subject to direct lightning strikes.	High	Best grounding recommendations must be closely followed.
Commercial building contains a mix of information technology equipment and industrial equipment, such as welding.	Medium to high	Best grounding recommendations must be closely followed.
Existing commercial building is not subject to natural environmental noise or man-made industrial noise. This building contains a standard office environment. This installation has a history of malfunction due to electromagnetic noise.	Medium	Determine source and cause of noise if possible, and mitigate as closely as possible at the noise source or reduce coupling from the noise source to the affected equipment. Best grounding recommendations must be closely followed.
New commercial building is not subject to natural environmental noise or man-made industrial noise. This building contains a standard office environment.	Low	Electromagnetic noise problems are not anticipated, but installing a grounding system in a new building is often the least expensive route and the best way to plan for the future. Best grounding recommendations should be followed as closely as possible.
Existing commercial building is not subject to natural environmental noise or man-made industrial noise. This building contains a standard office environment.	Low	Electromagnetic noise problems are not anticipated, but installing a grounding system is always recommended. Best grounding recommendations should be followed as much as possible.

**Note**

In all situations, grounding practices must comply with local National Electric Code (NEC) requirements or local laws and regulations.

**Note**

Always ensure that all of the modules are completely installed and that the captive installation screws are fully tightened. In addition, ensure that all I/O cables and power cords are properly seated. These practices are normal installation practices and must be followed in all installations.

Preventing Electrostatic Discharge Damage

Electrostatic discharge (ESD) damage, which can occur when modules or other FRUs are improperly handled, results in intermittent or complete failures. Modules consist of printed circuit boards that are fixed in metal carriers. Electromagnetic interference (EMI) shielding and connectors are integral components of the carrier. Although the metal carrier helps to protect the board from ESD, always use an ESD grounding strap when handling modules.

For preventing ESD damage, follow these guidelines:

- Always use an ESD wrist strap and ensure that it makes maximum contact with bare skin.
- ESD grounding straps are available with banana plugs, metal spring clips, or alligator clips. All chassis from the Cisco Nexus 6000 series are equipped with a banana plug connector (identified by the ground symbol next to the connector) somewhere on the front panel. We recommend that you use a personal ESD grounding strap equipped with a banana plug.
- If you choose to use the disposable ESD wrist strap supplied with most FRUs or an ESD wrist strap equipped with an alligator clip, you must attach the system ground lug to the chassis in order to provide a proper grounding point for the ESD wrist strap.

**Note**

This system ground is also referred to as the network equipment building system (NEBS) ground.

- If your chassis does not have the system ground attached, you must install the system ground lug. See the [“Establishing the System Ground” section on page 2-10](#) for installation instructions and location of the chassis system ground pads.

**Note**

You do not need to attach a supplemental system ground wire to the system ground lug; the lug provides a direct path to the bare metal of the chassis.

After you install the system ground lug, follow these steps to correctly attach the ESD wrist strap:

- Step 1** Attach the ESD wrist strap to bare skin as follows:
- a. If you are using the ESD wrist strap supplied with the FRUs, open the wrist strap package and unwrap the ESD wrist strap. Place the black conductive loop over your wrist and tighten the strap so that it makes good contact with your bare skin.
 - b. If you are using an ESD wrist strap equipped with an alligator clip, open the package and remove the ESD wrist strap. Locate the end of the wrist strap that attaches to your body and secure it to your bare skin.
- Step 2** Grasp the spring or alligator clip on the ESD wrist strap and momentarily touch the clip to a bare metal spot (unpainted surface) on the rack. We recommend that you touch the clip to an unpainted rack rail so that any built-up static charge is then safely dissipated to the entire rack.

Step 3 Attach either the spring clip or the alligator clip to the ground lug screw as follows:

- a. If you are using the ESD wrist strap that is supplied with the FRUs, squeeze the spring clip jaws open, position the spring clip to one side of the system ground lug screw head, and slide the spring clip over the lug screw head so that the spring clip jaws close behind the lug screw head.



Note The spring clip jaws do not open wide enough to fit directly over the head of the lug screw or the lug barrel.

- b. If you are using an ESD wrist strap that is equipped with an alligator clip, attach the alligator clip directly over the head of the system ground lug screw or to the system ground lug barrel.

To attach the ESD wrist strap to the system ground lug screw for any of the Cisco Nexus 6000 switches, clip the grounding wire to the screw that attaches the grounding lug to the switch chassis.

In addition, follow these guidelines when handling modules:

- Handle carriers by available handles or edges only; avoid touching the printed circuit boards or connectors.
- Place a removed component board-side-up on an antistatic surface or in a static-shielding container. If you plan to return the component to the factory, immediately place it in a static-shielding container.
- Never attempt to remove the printed circuit board from the metal carrier.



Caution

For safety, periodically check the resistance value of the antistatic strap. The measurement should be between 1 and 10 megohm (Mohm).

Establishing the System Ground

This section describes how to connect a system ground to the Cisco Nexus 6000 Series switch.

You must use the system ground on AC-powered systems if you are installing this equipment in a U.S. or European Central Office.

The system ground provides additional grounding for EMI shielding requirements and grounding for the low-voltage supplies (DC-DC converters) on the modules and is intended to satisfy the Telcordia Technologies requirements for supplemental bonding and grounding connections. You must observe the following system grounding guidelines for your chassis:

- You must install the system ground connection with any other rack or system power ground connections that you make. The system ground connection is required if this equipment is installed in a U.S. or European Central Office.
- You must connect both the system ground connection and the power supply ground connection to an earth ground. The system ground connection is required if this equipment is installed in a U.S. or European Central Office.
- You do not need to power down the chassis because the Cisco Nexus 6000 Series switches are equipped with AC-input power supplies.

Required Tools and Equipment

To connect the system ground, you need the following tools and materials:

- Grounding lug—A two-hole standard barrel lug. This lug supports up to 6 AWG wire. Supplied as part of accessory kit.
- Grounding screws—Two M4 x 8mm (metric) pan-head screws. These screws are supplied as part of the accessory kit.
- Grounding wire—Not supplied as part of accessory kit. The grounding wire should be sized according to local and national installation requirements. Depending on the power supply and system, a 12 AWG to 6 AWG copper conductor is required for U.S. installations. Commercially available 6 AWG wire is recommended. The length of the grounding wire depends on the proximity of the switch to proper grounding facilities.
- No. 1 Phillips screwdriver.
- Crimping tool to crimp the grounding wire to the grounding lug.
- Wire-stripping tool to remove the insulation from the grounding wire.

Grounding the Cisco Nexus 6000 Series Chassis

The chassis has a grounding pad with two threaded M4 holes for attaching a grounding lug. The location of the system ground on the Cisco Nexus 6000 switch is similar to that on the Cisco Nexus 5500 Platform switches.

**Note**

For the procedure on how to ground the Cisco Nexus 6000 Series switch chassis, see the [“Grounding the Cisco Nexus 6000 Series Chassis”](#) section on page 2-11.

**Warning**

When installing or replacing the unit, the ground connection must always be made first and disconnected last. Statement 1046

**Caution**

We recommend grounding the chassis, even if the rack is already grounded.

**Caution**

All power supplies must be grounded. The receptacles of the AC power cables used to provide power to the chassis must be the grounding type, and the grounding conductors should connect to protective earth ground at the service equipment.

**Warning**

When installing or replacing the unit, the ground connection must always be made first and disconnected last.

Statement 1046

**Caution**

Grounding the chassis is required if you are using DC power supplies, even if the rack is already grounded. A grounding pad with two threaded M4 holes is provided on the chassis for attaching a grounding lug. The ground lug must be NRTL listed. In addition, the copper conductor (wires) must be used and the copper conductor must comply with NEC code for ampacity.

To attach the grounding lug and cable to the chassis, follow these steps:

- Step 1** Use a wire-stripping tool to remove approximately 0.75 inches (19 mm) of the covering from the end of the grounding cable.
- Step 2** Insert the stripped end of the grounding cable into the open end of the grounding lug.
- Step 3** Use the crimping tool to secure the grounding cable in the grounding lug.
- Step 4** Remove the adhesive label from the grounding pad on the chassis.
- Step 5** Place the grounding lug against the grounding pad so that there is solid metal-to-metal contact, and insert the two M4 screws with washers through the holes in the grounding lug and into the grounding pad.
- Step 6** Ensure that the lug and cable do not interfere with other equipment.
- Step 7** Prepare the other end of the grounding cable and connect it to an appropriate grounding point in your site to ensure adequate earth ground.

Starting the Switch

This section provides instructions for powering up the Cisco Nexus 6000 switch and verifying the component installation.

**Note**

Do not connect the Ethernet port to the LAN until the initial switch configuration has been performed. For instructions on configuring the switch, see the *Cisco Nexus 6000 Series CLI Configuration Guide*. For instructions on connecting to the console port, see the [“Connecting to the Console Port” section on page 3-2](#).

**Warning**

When installing or replacing the unit, the ground connection must always be made first and disconnected last.

Statement 1046

To power up the switch and verify hardware operation, follow these steps:

- Step 1** Verify that empty power supply slots have filler panels installed, the faceplates of all modules are flush with the front of the chassis, and the captive screws of the power supplies, fan module, and all expansion modules are tight.
- Step 2** Verify that the power supply and the fan modules are installed.



Note Depending on the outlet receptacle on your power distribution unit, you may need the optional jumper power cord to connect the switch to your outlet receptacle. See the “[Jumper Power Cord](#)” section on page C-8.

- Step 3** Ensure that the switch is adequately grounded as described in the “[Grounding the Switch](#)” section on page 2-7, and that the power cables are connected to outlets that have the required AC power voltages (see the “[Power Specifications](#)” section on page B-3).
- Step 4** For the switch, insert each end of the power clip (from the accessory kit) into holes on tabs located on either side of the power connectors.
- Step 5** Connect each power cable to the power connectors on the chassis and an AC power source. Press the power cable into the power clip to ensure that the power cable stays connected to the chassis when bumped. The switch should power on as soon as you connect the power cable.
- Step 6** Listen for the fans; they should begin operating when the power cable is plugged in.
- Step 7** After the switch boots, verify that the LED operation is as follows:
- Fan module—Status LED is green.
 - Power supply—Status LED is green.
 - After initialization, the system status LED is green, indicating that all chassis environmental monitors are reporting that the system is operational. If this LED is orange or red, then one or more environmental monitor is reporting a problem.
 - The Link LEDs for the Ethernet connector should not be on unless the cable is connected.



Note The link LEDs for the Fibre Channel ports remain yellow until the ports are enabled, and the LED for the Ethernet connector port remains off until the port is connected.

- Step 8** Try removing and reinstalling a component that is not operating correctly. If it still does not operate correctly, contact your customer service representative for a replacement.



Note If you purchased this product through a Cisco reseller, contact the reseller directly for technical support. If you purchased this product directly from Cisco, contact Cisco Technical Support at this URL: <http://www.cisco.com/c/en/us/support/web/tsd-cisco-worldwide-contacts.html>.

- Step 9** Verify that the system software has booted and the switch has initialized without error messages. If you cannot resolve an issue, contact your customer service representative.
- Step 10** Complete the worksheets provided in [Appendix G, “Site Planning and Maintenance Records”](#) for future reference.



Note A setup utility automatically launches the first time you access the switch and guides you through the basic configuration. For instructions on how to configure the switch and check module connectivity, see the appropriate Cisco Nexus 6000 Series CLI configuration guide.

For the common sections: Add reference to the removed sections If your system is a 6004. and has shutters, lease remove them.

Installing a Reverse Airflow System for the Cisco Nexus 6004 Switch

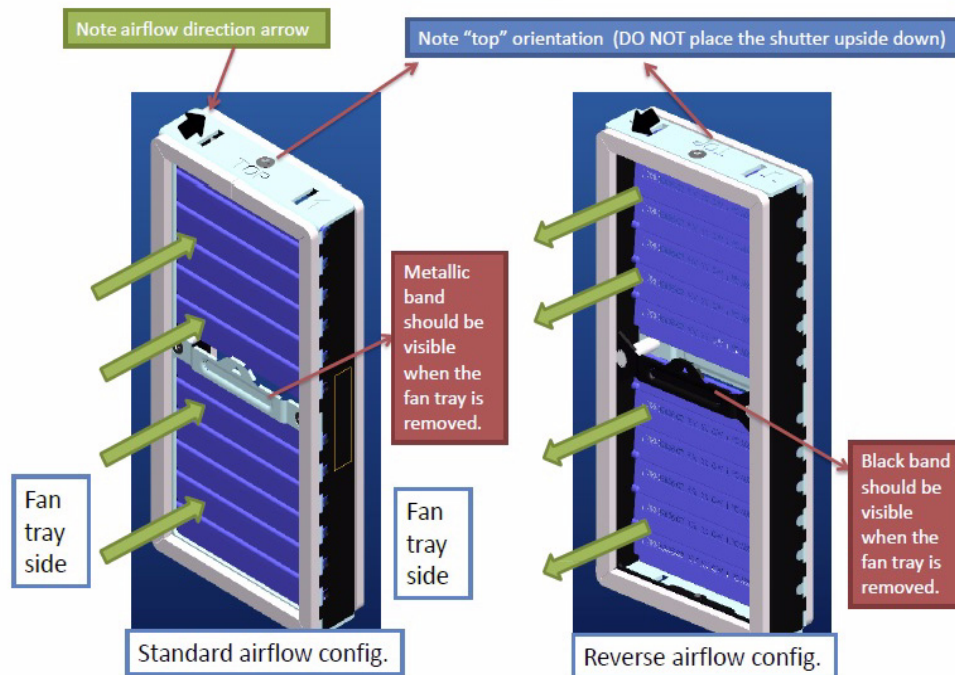
In a standard airflow configuration, cold air intake is from the fan side and hot air exhaust is from the port side. In a reverse airflow configuration, the cold air intake is from the port side and hot air exhaust is from the fan side. A reverse air flow system must have new reverse air flow fans (four sets), new reverse power supplies, and four reconfigured fan louvers.

A reverse airflow power supply is identified by a black colored stripe. A standard airflow power supply does not have a black colored stripe.

A reverse airflow fan tray (N6K-C6004-FAN-B) is identified by a black colored label near the STAT button. A standard airflow fan tray (N6K-C6004-FAN-F) is identified by a gray colored label near the status LED.

A reverse airflow configuration for an airflow shutter or fan louver (part number 800-38434-03), is identified by a black band that is visible when the fan tray is removed. It also has direction arrows engraved on the top side that should point towards the fan trays. A standard airflow configuration for a fan louver (part number 800-38434-03), is identified by a metallic band that is visible when the fan tray is removed. In this configuration the direction arrows on the top side should point towards the port side. A standard airflow configuration and reverse airflow configuration for louvers are shown in [Figure 2-2](#).

Figure 2-2 Standard Airflow Configuration and Reverse Airflow Configuration for Louvers

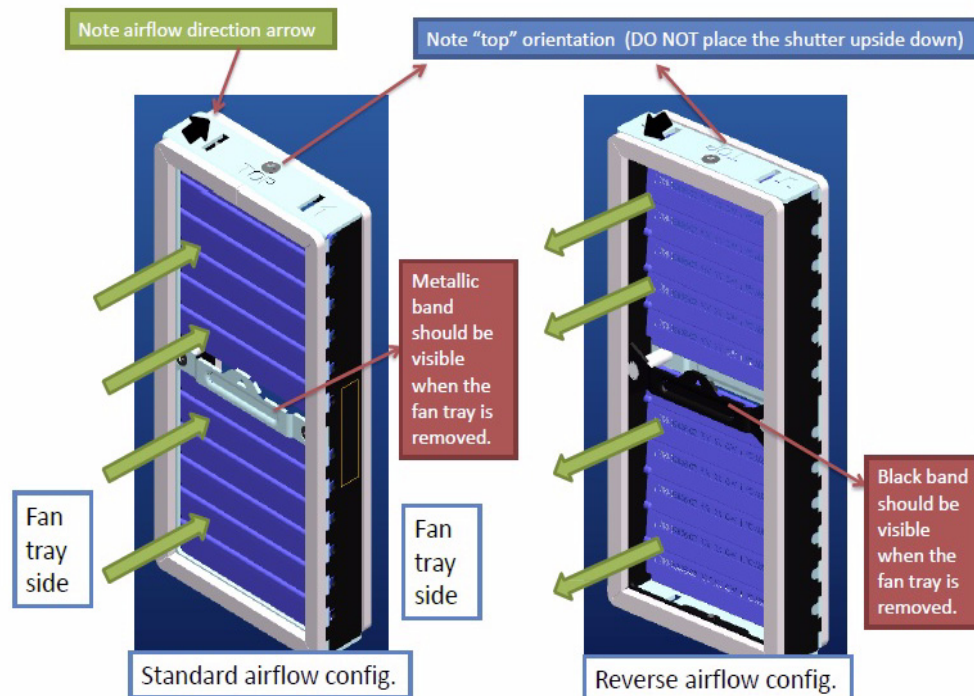


Caution

When converting the system airflow direction, the fan louvers must be removed and rotated 180 degrees so that the airflow direction arrows on top of the louvers match the configuration.

Fan louver installation is shown in [Figure 2-3](#).

Figure 2-3 Fan Louver Installation



To install a fan louver, follow these steps:

-
- Step 1** Engage the latch into the bottom slots.
 - Step 2** Push the handle until the top latch snaps in.
-

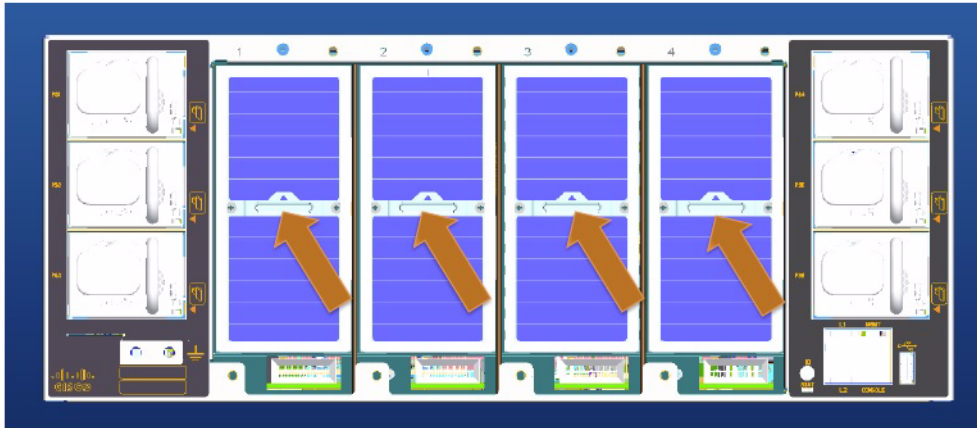
To remove a fan louver, follow this step:

-
- Step 1** Hold the handle and pull towards you.
-

Removing Fan Shutters

The Cisco Nexus 6004 systems do not need the fan shutter assembly in the chassis. To remove a fan shutter from the system, follow these steps:

-
- Step 1** Loosen the thumb screws and then remove all the fan trays.
 - Step 2** Hold the cross bar in the middle and pull out all the shutters. See [Figure 2-4](#)

Figure 2-4 Fan Shutter Removal

Step 3 Put the fan trays back in and tighten the thumbscrews.



CHAPTER 3

Connecting the Switch

This chapter describes how to connect the Cisco Nexus 6000 Series switches to the following types of ports:

- Console port —A port that you can use to create a local management connection.
- Ethernet ports, both encrypted and unencrypted—These ports can be used to connect to a LAN.



Caution

When running power and data cables in overhead or subfloor cable trays, we strongly recommend that you locate power cables and other potential noise sources as far away as practical from network cabling that terminates on Cisco equipment. In situations where long parallel cable runs cannot be separated by at least 3.3 ft (1 m), we recommend that you shield any potential noise sources by housing them in a grounded metallic conduit.

This chapter includes the following sections:

- [Preparing for Network Connections, page 3-2](#)
- [Connecting to the Console Port, page 3-2](#)
- [Connecting to the Ethernet Connector Port, page 3-3](#)
- [Connecting to an Ethernet Port, page 3-3](#)

Preparing for Network Connections

When preparing your site for network connections to the Cisco Nexus 6000 switch, consider the following for each type of interface, and gather all the required equipment before connecting the ports:

- Cabling required for each interface type
- Distance limitations for each signal type
- Additional interface equipment required

Connecting to the Console Port

The console port is an RS-232 port with an RJ-45 interface. The console port is an asynchronous (async) serial port; any device connected to this port must be capable of asynchronous transmission.

We recommend using this port to create a local management connection to set the IP address and other initial configuration settings before connecting the switch to the network for the first time.



Caution

The console port can be used to connect to a modem. If you do not connect it to a modem, connect it either before powering the switch on or after the switch has completed the boot process.

You can use the console port to perform the following:

- Configure the Cisco Nexus 6000 switch from the CLI.
- Monitor network statistics and errors.
- Configure SNMP agent parameters.
- Download software updates.



Note

To connect the console port to a computer terminal, the computer must support VT100 terminal emulation. The terminal emulation software (such as HyperTerminal or Procomm Plus) makes communication between the Cisco Nexus 6000 switch and a computer possible during setup and configuration.

To connect the console port to a computer terminal, follow these steps:

Step 1 Configure the terminal emulator program to match the following default port characteristics: 9600 baud, 8 data bits, 1 stop bit, no parity.

Step 2 Connect the RJ-45 connector of the console cable to the console port and the DB-9 connector to the computer serial port.



Note

For configuration instructions, see the appropriate *Cisco Nexus 6000 Series CLI configuration guide*.

Connecting to the Ethernet Connector Port

**Caution**

To prevent an IP address conflict, do not connect the management port to the network until the initial configuration is complete. For configuration instructions, see the *Cisco Nexus 6000 Series CLI Configuration Guide*.

This section describes how to connect the Ethernet connector port to an external hub, switch, or router. The Ethernet connector port has an RJ-45 interface. To connect the Ethernet connector port to an external hub, switch, or router, follow these steps:

-
- Step 1** Connect the appropriate modular cable to the Ethernet connector port:
- Use modular, RJ-45, straight-through UTP cables to connect the Ethernet connector port to an Ethernet switch port or hub.
 - Use a cross-over cable to connect to a router interface.
- Step 2** Connect the other end of the cable to the device.
-

Connecting to an Ethernet Port

To connect to an Ethernet port, you must install transceivers and connect them with optical cables.

This section includes the following topics:

- [Installing and Replacing Transceivers, page 3-3](#)
- [Installing Cables into Transceivers, page 3-5](#)

Installing and Replacing Transceivers

**Caution**

Excessively removing and installing a transceiver can shorten its life. Unless it is absolutely necessary, do not remove and insert transceivers. To prevent damage to the cable and transceiver, we recommend that you disconnect cables before installing or removing transceivers.

This section includes the following topics:

- [Installing a Transceiver, page 3-3](#)
- [Replacing a Transceiver, page 3-4](#)

Installing a Transceiver

To install a transceiver, follow these steps:

-
- Step 1** Attach an ESD-preventive wrist strap and follow its instructions for use.

- Step 2** Remove the dust cover from the port cage.
- Step 3** Remove the dust cover from the port end of the transceiver.
- Step 4** Insert the transceiver into the port as follows:
- If the transceiver has a Mylar tab latch, position the transceiver with the tab on the bottom, and then gently insert the transceiver into the port until it clicks into place.
 - If the transceiver has a bale clasp latch, position the transceiver with the clasp on the bottom, close the clasp by pushing it up over the transceiver, and then gently insert the transceiver into the port until it clicks into place.

**Caution**

If the transceiver does not install easily, ensure that it is correctly positioned and the tab or clasp are in the correct position before continuing.

**Note**

If you cannot install the cable into the transceiver, insert or leave the dust plug in the cable end of the transceiver.

Replacing a Transceiver

To replace a transceiver, follow these steps:

- Step 1** Attach an ESD-preventive wrist strap and follow its instructions for use.
- Step 2** If a cable is installed in the transceiver, do the following:
- a. Record the cable and port connections for later reference.
 - b. Press the release latch on the cable, grasp the connector near the connection point, and gently pull the connector from the transceiver.
 - c. Insert a dust plug into the cable end of the transceiver.

**Caution**

If the transceiver does not remove easily in the next step, push the transceiver completely in and then ensure that the latch is in the correct position before continuing.

- Step 3** Remove the transceiver from the port as follows:
- If the transceiver has a Mylar tab latch, gently pull the tab straight out (do not twist), and then pull the transceiver out of the port.
 - If the transceiver has a bale clasp latch, open the clasp by pressing it downward, and then pull the transceiver out of the port.

**Note**

If you have difficulty removing a bale clasp transceiver, you should reseal it by returning the bale clasp latch to the up position. Press the transceiver inward and upward into the cage. Next, lower the bale clasp latch and pull the transceiver straight out with a slight upward lifting force. Be careful not to damage the port cage during this process.

- Step 4** Insert a dust cover into the port end of the transceiver and place the transceiver on an antistatic mat or into a static shielding bag if you plan to return it to the factory.
- Step 5** Install a replacement transceiver (see the “[Installing a Transceiver](#)” section on page 3-3). If another transceiver is not being installed, protect the optical cage by inserting a clean cover.
-

Installing Cables into Transceivers

**Caution**

To prevent damage to the copper cables, do not place more tension on them than the rated limit and do not bend to a radius of less than 1 inch (2.54 cm) if there is no tension in the cable, or 2 inches (5.08 cm) if there is tension in the cable.

This section includes the following topics:

- [Installing a Cable into an Transceiver, page 3-5](#)
- [Replacing a Cable for a Transceiver, page 3-5](#)

Installing a Cable into an Transceiver

**Caution**

To prevent possible damage to the cable or transceiver, install the transceiver in the port before installing the cable in the transceiver.

To install a cable into a transceiver, follow these steps:

- Step 1** Attach an ESD-preventive wrist strap and follow its instructions for use.
- Step 2** Remove the dust cover from the connector on the cable.
- Step 3** Remove the dust cover from the cable end of the transceiver.
- Step 4** Align the cable connector with the transceiver and insert the connector into the transceiver until it clicks into place.

**Caution**

If the cable does not install easily, ensure that it is correctly positioned before continuing.

For instructions on verifying connectivity, see the appropriate *Cisco Nexus 6000 Series CLI Configuration Guide*.

Replacing a Cable for a Transceiver

**Caution**

When pulling a cable from a transceiver, grip the body of the connector. Do not pull on the jacket sleeve, because this action can compromise the fiber-optic termination in the connector.

**Caution**

If the cable does not remove easily, ensure that any latch present on the cable has been released before continuing.

To remove the cable, follow these steps:

-
- Step 1** Attach an ESD-preventive wrist strap and follow its instructions for use.
- Step 2** Press the release latch on the cable, grasp the connector near the connection point, and gently pull the connector from the transceiver.
- Step 3** Either install a replacement cable in the transceiver (see the [“Installing a Cable into an Transceiver” section on page 3-5](#)) or insert dust plugs into the cable end of the transceiver and the end of the removed cable.
-



CHAPTER 4

Replacing Components

This chapter describes how to remove and install components for the Cisco Nexus 6000 Series switches.

This section includes the following sections:

- [Replacing Expansion Modules, page 4-1](#)
- [Replacing LEMs, page 4-2](#)
- [Replacing Modules, page 4-3](#)
- [Replacing or Installing Power Supplies, page 4-4](#)
- [Replacing a Fan Module, page 4-7](#)
- [Removing the Cisco Nexus 6000 Platform Chassis, page 4-8](#)

Replacing Expansion Modules



Caution

To prevent ESD damage, wear grounding wrist straps during these procedures and handle expansion modules by the carrier edges only.

Install the switch in the rack before installing expansion modules. For information about installing the chassis, see the [“Installing the Switch” section on page 2-5](#).

This section includes the following topics:

- [Removing an Expansion Module from a Cisco Nexus 6000 Platform Chassis, page 4-1](#)
- [Installing an Expansion Module in a Cisco Nexus 6000 Platform Chassis, page 4-2](#)

Removing an Expansion Module from a Cisco Nexus 6000 Platform Chassis

To remove an expansion module from the Cisco Nexus 6000 Platform switch chassis, follow these steps:

- Step 1** Poweroff the module using the **poweroff module <x>** command.
- Step 2** Disconnect any network interface cables attached to the module.
- Step 3** Open the packing materials for the module and prepare an antistatic surface for uninstalled modules.
- Step 4** Loosen the captive screw on the ejector lever so that the lever can move.

-
- Step 5** Rotate the ejector lever from the front of the module until it stops at about 45 degrees from the front. Be careful not to bend the latch.
 - Step 6** With one hand on the ejector handle and front of the module, pull the module part way out of its slot in the chassis.
 - Step 7** Place your other hand under the module to support its weight and fully remove the module.
 - Step 8** Place the module on an antistatic surface or pack it in its packing materials.
-

Installing an Expansion Module in a Cisco Nexus 6000 Platform Chassis

To install an expansion module in a Cisco Nexus 6000 Platform switch chassis, follow these steps:

-
- Step 1** Remove the module from its packing materials and place it on an antistatic surface.
 - Step 2** If the captive screw on the expansion module is not loose, turn it counterclockwise to fully loosen.
 - Step 3** Rotate the ejector lever away from the front of the module until it stops at about 45 degrees from the front. Be careful not to bend the latch.
 - Step 4** Holding the module with one hand on the front of the module and the other hand on its carrier edges or bottom, align the module to the open slot.
 - Step 5** Push the module fully into the slot until the ejector engages and the lever moves.
 - Step 6** Rotate the ejector lever to the front of the module so that the module is fully inserted in the slot and the captive screw on the ejector assembly is in position to screw into the expansion module.
 - Step 7** Tighten the captive screw to the expansion module.
 - Step 8** Verify the installation by making sure that the module status LED turns on and is green.
-

Replacing LEMs

This section includes the following topics:

- [Removing a LEM, page 4-2](#)
- [Installing a LEM, page 4-3](#)

Removing a LEM

To remove a LEM from a Cisco Nexus 6004 chassis, follow these steps:

-
- Step 1** Power off the LEM using **poweroff module <x>**
 - Step 2** Physically remove the LEM.
-

Installing a LEM

To install a LEM in a Cisco Nexus 6004 chassis, follow these steps:

-
- Step 1** Insert the LEM into the slot and make sure it is firmly installed.
 - Step 2** The LEM will auto power on if the poweroff command was not executed earlier on this slot. Otherwise **no poweroff module <x>** will power it on.
-

If the following error message is observed, remove and reinsert the LEM as per guidelines:

```
2013 Feb 21 23:05:17 switch %$ VDC-1 %$ %USER-2-SYSTEM_MSG: Module 5 might not have been seated properly. Please remove and re-insert the module.
```

If the error persists beyond 3 attempts, contact customer support.

Replacing Modules

This section includes the following topics:

- [Removing a Module, page 4-3](#)
- [Installing a Module, page 4-3](#)

Removing a Module

To remove a module from a Cisco Nexus 6000 chassis, follow these steps:

-
- Step 1** Shut all the ports on the module
 - Step 2** Poweroff the module using the **poweroff module <x>** command.
 - Step 3** Physically remove the module.
-

Installing a Module

To install a module in a Cisco Nexus 6000 chassis, follow these steps:

-
- Step 1** Insert the module into the slot and make sure it is firmly installed.
 - Step 2** Power on the module using the command **no poweroff module <x>**
 - Step 3** Bring up the ports on the module by issuing ‘no shut’ on the interfaces of the module
-

Replacing or Installing Power Supplies

The Cisco Nexus 6000 series support six power supplies, but may be used with three power supplies. You must fill the unused power supply slots with a blank modules to maintain the designed airflow.

If you need to replace an existing power supply, follow the procedures that explain how to remove and install power supplies. If you are installing a new power supply where one did not exist before, follow the installation procedure.

**Note**

The airflow direction must be the same for all power supply and fan modules in the chassis. You can order all modules with front to back airflow but you can alternatively order back to front airflow

This section includes the following topics:

- [Removing a Power Supply, page 4-4](#)
- [Installing a Power Supply, page 4-4](#)
- [Wiring a DC Power Connector, page 4-5](#)

**Note**

You can replace a faulty power supply while the system is operating if the other power supply is functioning.

Removing a Power Supply

**Caution**

If you are using a Cisco Nexus 6000 Platform removing the power supply causes the switch to shut down. If you are using two power supplies and you remove one of them, the switch can continue to operate.

To remove an AC or DC power supply, follow these steps:

- Step 1** Ensure that the system (earth) ground connection has been made. For ground connection instructions, see the [“Grounding the Switch” section on page 2-7](#).
- Step 2** Remove the AC power cord or DC wiring connector.
- Step 3** Grasp the power supply handle with your left hand.
- Step 4** Push against the release latch with your left thumb, and slide the power supply part way out of the chassis.
- Step 5** Place your other hand under the power supply to support its weight, and then completely remove the module from the slot.
- Step 6** If the power supply bay is to remain empty, install a blank power supply filler panel. If you are replacing the power supply, see [Installing a Power Supply, page 4-4](#)

Installing a Power Supply

To install a power supply in a Cisco Nexus 6000 Platform chassis, follow these steps:

- Step 1** Ensure that the system (earth) ground connection has been made. For ground connection instructions, see the [“Grounding the Switch”](#) section on page 2-7.
- Step 2** If the power supply bay has a filler panel, press the latches on the sides of the filler panel, and then slide it out of the power supply bay.
- Step 3** Hold the power supply by the handle and position it so that the release latch is on the right, and then slide it into the power supply bay, ensuring that the power supply is fully seated in the bay.
- Step 4** Plug the AC power cable or DC wiring connector into the inlet receptacle at the rear of the chassis. For a DC installation, you should secure the plug to the power supply by tightening both captive screws on the plug.



Note Depending on the outlet receptacle on your power distribution unit, you may need the optional jumper power cord to connect the Cisco Nexus 6000 switch to your outlet receptacle. See the [“Jumper Power Cord”](#) section on page C-8.

- Step 5** Connect the other end of the power cable to an AC power source. DC sources should connect negative (black wire) and then positive (red wire) connections.



Caution In a system with dual power supplies, connect each power supply to a separate power source. In case of a power source failure, the second source will most likely still be available.

- Step 6** Verify the power supply operation by checking that the power supply LED is green.

Wiring a DC Power Connector



Warning

A readily accessible two-poled disconnect device must be incorporated in the fixed wiring. Statement 1022



Warning

This product requires short-circuit (overcurrent) protection, to be provided as part of the building installation. Install only in accordance with national and local wiring regulations. Statement 1045



Warning

When installing or replacing the unit, the ground connection must always be made first and disconnected last. Statement 1046



Warning

Installation of the equipment must comply with local and national electrical codes. Statement 1074



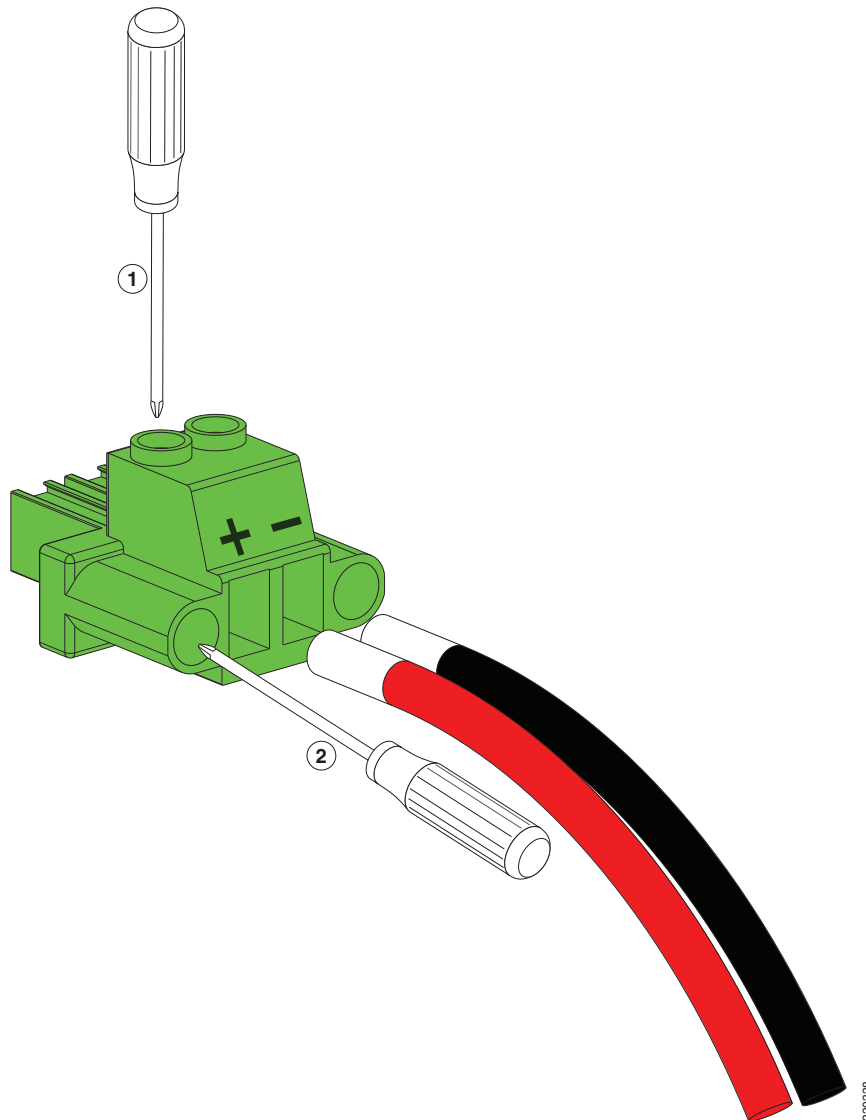
Warning

Hazardous voltage or energy may be present on DC power terminals. Always replace cover when terminals are not in service. Be sure uninsulated conductors are not accessible when cover is in place. Statement 1075

Before installing a DC power supply to the switch, you will need to attach DC connection wires that you provide (10 GA recommended) to the DC power connector included in the DC power supply's accessory kit. To wire the connector:

- Step 1** Using a 1/8" flat head screwdriver or No. 1 Phillips head screwdriver, loosen the set screws on the connector to freely accept the power wires. The connector will accept 8-24 AWG wires, use what your local electrical code calls for.
- Step 2** Strip 1/2" of insulation off the DC wires you will use.
- Step 3** Insert the black (DC negative) wire into the right aperture on the connector and tighten down the connection set screw. Finger tight or about 3 ft./lbs should be sufficient.
- Step 4** Insert the red (DC positive) wire into the left aperture on the connector and tighten down the connection set screw. Do not tighten over 0.7 Nm.

Figure 4-1 Wiring the DC Power Connector



Replacing a Fan Module

The fan module is designed to be removed and replaced while the system is operating without presenting an electrical hazard or damage to the system, if the replacement is performed promptly.

**Note**

The airflow direction must be the same for all power supply and fan modules in the chassis. You can order all modules with front to back airflow but you can alternatively order back to front airflow.

On Cisco Nexus 6000 Series Switches, forward airflow ejector on the fan side intake is blue in color, and the reverse airflow ejector on the port side intake is maroon in color. However, for Cisco Nexus 6004 switches, the reverse airflow ejector on the port side intake has a black stripe.

The fan module has the following PID:

- N6K-C6001-FAN-F—Forward Airflow (Fan Side Intake)
- N6K-C6001-FAN-B—Reverse Airflow (Port Side Intake)

This section includes the following topics:

- [Removing a Fan Module, page 4-7](#)
- [Installing a Fan Module, page 4-7](#)

Removing a Fan Module

**Warning**

When removing the fan tray, keep your hands and fingers away from the spinning fan blades. Let the fan blades completely stop before you remove the fan tray. Statement 258

To remove a fan module, follow these steps:

- Step 1** Loosen the captive screws on the fan module by turning them counterclockwise, using a flat-blade or number 2 Phillips screwdriver if required.
- Step 2** Grasp the handle of fan module and pull it outward.
- Step 3** Pull the fan module clear of the chassis.

Installing a Fan Module

To install a fan module, follow these steps:

- Step 1** Hold the fan module with the LED at the bottom.
- Step 2** Place the fan module into the front chassis fan slot so it rests on the chassis, and then push the fan module into the chassis as far as it can go until the captive screw makes contact with the chassis, and tighten the captive screw.

- Step 3** If the switch is powered on, listen for the fans. You should immediately hear them operating. If you do not hear them, ensure that the fan module is inserted completely in the chassis and the faceplate of the module is flush with the outside surface of the chassis.
- Step 4** Verify that the fan module LED is green. If the LED is not green, one or more fans are faulty. If this situation occurs, contact your customer service representative for replacement parts.

**Note**

If you purchased this product through a Cisco reseller, contact the reseller directly for technical support. If you purchased this product directly from Cisco, contact Cisco Technical Support at this URL: <http://www.cisco.com/c/en/us/support/web/tsd-cisco-worldwide-contacts.html>.

Removing the Cisco Nexus 6000 Platform Chassis

**Caution**

The slider rail and front rack-mount brackets do not have a stop mechanism when sliding in and out. If the front of the chassis is unfastened from the rack and the chassis slides forward on the slider rails, it might slip off the end of the rails and fall out of the rack.

To remove the Cisco Nexus 6000 Platform chassis from a rack, follow these steps:

-
- Step 1** Ensure that the weight of the switch is fully supported and that the switch is being held by another person.
- Step 2** Disconnect the power cord and the console cables.
- Step 3** Disconnect all cables that are connected to transceivers.
- Step 4** Remove the screws fastening the front rack-mount brackets to the mounting rails.
- Step 5** Gently slide the switch towards you, off of the slider rails and out of the rack.
-

Repacking Cisco Nexus 6000 Platform Switch Components or Cisco Nexus Platform Switch Components for Return Shipment

If you need to return the switch, remove the switch from the rack by following the steps in the [“Removing the Cisco Nexus 6000 Platform Chassis”](#) section on page 4-8, and repack it for shipment. If possible, use the original packing materials and container to repack the switch. Contact your Cisco customer service representative to arrange for return shipment to Cisco.



APPENDIX **A**

Cabinet and Rack Installation

This appendix provides the requirements for cabinet and rack installation for the Cisco Nexus 6000 switch and includes the following sections:

- [Cabinet and Rack Requirements, page A-1](#)
- [Cable Management Guidelines, page A-2](#)

Cabinet and Rack Requirements

This section provides the requirements for the following types of cabinets and racks, assuming an external ambient air temperature range of 0 to 104°F (0 to 40°C):

- Standard perforated cabinets
- Standard open racks



Note

If you are selecting an enclosed cabinet, we recommend one of the thermally validated types: standard perforated or solid-walled with a fan tray.



Note

Do not use racks that have obstructions (such as power strips), because the obstructions could impair access to field-replaceable units (FRUs).

This section includes the following topics:

- [General Requirements for Cabinets and Racks, page A-1](#)
- [Requirements Specific to Perforated Cabinets, page A-2](#)

General Requirements for Cabinets and Racks

The cabinet or rack must be one of the following types:

- Standard 19-in. (48.3 cm) (four-post EIA cabinet or rack, with mounting rails that conform to English universal hole spacing per section 1 of ANSI/EIA-310-D-1992. See the [“Requirements Specific to Perforated Cabinets”](#) section on page A-2.

The cabinet or rack must also meet the following requirements:

- The minimum vertical rack space for the Cisco Nexus 6004 chassis must be four RU (rack units).

- The width between the rack-mounting rails must be at least 19 inches if the rear of the switch is not attached to the rack. For four-post EIA racks, this is the distance between the two front rails.
- For four-post EIA cabinets (perforated or solid-walled), the requirements are as follows:
 - The minimum spacing for the bend radius for fiber-optic cables should have the front-mounting rails of the cabinet offset from the front door by a minimum of 3 inches (7.6 cm), and a minimum of 5 inches (12.7 cm) if cable management brackets are installed on the front of the chassis.
 - The distance between the outside face of the front mounting rail and the outside face of the back mounting rail should be 23.5 to 34.0 inches (59.7 to 86.4 cm) to allow for rear-bracket installation.
 - A minimum of 2.5 inches (6.4 cm) of clear space should exist between the side edge of the chassis and the side wall of the cabinet. No sizeable flow obstructions should be immediately in the way of chassis air intake or exhaust vents.

**Note**

Optional jumper power cords are available for use in a cabinet. See the [“Jumper Power Cord” section on page C-8](#).

Requirements Specific to Perforated Cabinets

A perforated cabinet is as a cabinet with perforated front and rear doors and solid side walls. In addition to the requirements listed in the [“General Requirements for Cabinets and Racks” section on page A-1](#), perforated cabinets must meet the following requirements:

- The front and rear doors must have at least a 60 percent open area perforation pattern, with at least 15 square inches (96.8 square cm) of open area per rack unit of door height.
- The roof should be perforated with at least a 20 percent open area.
- The cabinet floor should be open or perforated to enhance cooling.

Cisco provides an R-Series rack that conforms to these requirements.

Cable Management Guidelines

To help with cable management, you might want to allow additional space in the rack above and below the chassis to make it easier to route as many as 56 fiber or copper cables through the rack.



APPENDIX **B**

Technical Specifications

This appendix describes the technical specifications for the Cisco Nexus 6000 switch.

This appendix includes the following sections:

- [Switch Specifications, page B-1](#)
- [Environmental Specifications, page B-2](#)
- [Expansion Module Specifications, page B-2](#)
- [Power Specifications, page B-3](#)



Note

Specifications for cables and connectors are provided in [Appendix C, “Cable and Port Specifications.”](#)

Switch Specifications

[Table B-1](#) lists the physical specifications for the Cisco Nexus 6001 switch.

Table B-1 *Physical Specifications for the Cisco Nexus 6001Switch*

Description	Specification
Dimensions (H x W x D)	1.75 inches (4.4 cm) tall, 17.3 inches (43.9 cm) wide, and 30 inches (76.2 cm) deep
Cisco Nexus 6001	31.5lbs

[Table B-2](#) lists the physical specifications for the Cisco Nexus 6004 switch.

Table B-2 *Physical Specifications for the Cisco Nexus 6004Switch*

Description	Specification
Dimensions (H x W x D)	(17.7 cm) tall, 17.3 inches (43.9 cm) wide, and 30 inches (76.2 cm) deep

Table B-2 *Physical Specifications for the Cisco Nexus 6004Switch*

Description	Specification
Cisco Nexus 6004 with three 1100W power supplies, four expansion modules, and four fan modules	122 lb
Cisco Nexus 6004 with three 1100W power supplies and four fan modules	100 lb

Environmental Specifications

[Table B-3](#) lists the environmental specifications for the Cisco Nexus 6001switch.

Table B-3 *Environmental Specifications for the Cisco Nexus 6001switch*

Property	Cisco Nexus 6001Switch
Operating temperature	32 to 104°F (0 to 40°C)
Nonoperating (storage) temperature	–40 to 158°F (–40 to 70°C)
Humidity	5 to 95% (noncondensing)
Altitude	0 to 10,000 ft (0 to 3000 m)

[Table B-4](#) lists the environmental specifications for the Cisco Nexus 6004 switch.

Table B-4 *Environmental Specifications for the Cisco Nexus 6004 switch*

Property	Cisco Nexus 6004Switch
Operating temperature	32 to 104°F (0 to 40°C)
Nonoperating (storage) temperature	–40 to 158°F (–40 to 70°C)
Humidity	5 to 95% (noncondensing)
Altitude	0 to 10,000 ft (0 to 3000 m)

Expansion Module Specifications

[Table B-5](#) lists the physical specifications for the Cisco Nexus 6004 switch expansion module.

Table B-5 *Physical Specifications for the Cisco Nexus 6004 Switch Expansion Module*

Description	Specification
Weight	1 lb (0.5 kg)

Power Specifications

This section describes the power specifications for the Cisco Nexus 6000 Series switches. This section includes the following topics:

- [Specifications for the Cisco Nexus 6001 Power Supply, page B-3](#)
- [Specifications for the Cisco Nexus 6004 Power Supply, page B-4](#)

Specifications for the Cisco Nexus 6001 Power Supply

[Table B-6](#) lists the specifications for the Cisco Nexus NXA-PAC-1100W and N55-PAC-1100W AC power supplies.

Table B-6 **Specifications for the Cisco Nexus NXA-PAC-1100W and N55-PAC-1100W AC Power Supplies**

AC Power Supply Properties	Specification
Maximum rated power output	1100W
Typical operating power consumption	750W
Maximum power consumption	1100W
Maximum AC input current (@100VAC, 200VAC)	13A, 7A
Input voltage	94 to 264 VAC
Frequency	47 to 63 Hz
Efficiency	94% (at 50% load)
RoHS compliance	Yes
Hot swappable	Yes
Front-to-back air flow power supply	Yes
Back-to-front air flow power supply	Yes

[Table B-7](#) lists the specifications for the Cisco Nexus NXA-PHV-1100W power supply.

Table B-7 **Specifications for the Cisco Nexus NXA-PHV-1100W Power Supply**

Power Supply Properties	Specification
Maximum rated power output	1100W
Typical operating power consumption	750W
Maximum power consumption	1100W
Maximum input current (@240 VDC, 380 VDC, 277 VAC)	5.5A, 3.5A, 4.7A
Input voltage range	192 to 400 VDC, 90 to 295 VAC
Efficiency	94% (50% load)
RoHS compliance	Yes
Hot swappable	Yes

Table B-8 lists the specifications for the Cisco Nexus N55-PDC-1100W DC Power Supply.

Table B-8 *Specifications for the Cisco Nexus N55-PDC-1100W DC Power Supply*

Power Supply Properties	Specification
Maximum rated power output	1100W
Typical operating power consumption	1100W
Maximum power consumption	1100W
Maximum DC input current (-40 VDC)	32A
Input DC voltage range	-40 to -72 VDC
Efficiency	92% (at 50% load)
RoHS compliance	Yes
Hot swappable	Yes

Specifications for the Cisco Nexus 6004 Power Supply

Table B-9 lists the power supply properties of the Cisco Nexus 6004 platform.

Table B-9 *Specifications for the Cisco Nexus 6004 Power Supply*

AC Power Supply Properties	Specification
Typical operating power	2800 W
Maximum power	3300 W
Input voltage	94 to 240 VAC
Frequency	47 to 63Hz
Efficiency	98% (50 to 100% load)
RoHS compliance	Yes
Hot swappable	Yes
Heat dissipation	11260 BTU/hr (3300W)
Front-to-back air flow power supply	Yes
Back-to-front air flow power supply	Yes



APPENDIX **C**

Cable and Port Specifications

This appendix provides cable and port specifications for the Cisco Nexus 6000 Series switch.

This appendix includes the following sections:

- [Cable RJ-45 Connector Pinouts, page C-1](#)
- [Console Port, page C-2](#)
- [Supported Power Cords and Plugs, page C-2](#)
- [Jumper Power Cord, page C-8](#)

Cable RJ-45 Connector Pinouts

[Table C-1](#) lists the pinouts for the RJ-45 connector on the console cable.

Table C-1 Cable Connector Pinouts

Signal Name	P1, P1-45 Pins	P2, DB-9 Pins	Signal Name
RTS	1	8	CTS
DTR	2	6	DSR
TXD	3	2	ZXD
GND	4	5	GND
GND	5	5	GND
ZXD	6	3	TXD
DSR	7	4	DTR
CTS	8	7	RTS

Console Port

The console port is an asynchronous RS-232 serial port with an RJ-45 connector.

Supported Power Cords and Plugs

Each power supply has a separate power cord. Standard power cords or jumper power cords are available for connection to a power distribution unit that has IEC 60320 C19 outlet receptacles. The standard power cords have an IEC C13 connector on the end that plugs into the switch. The optional jumper power cords, for use in cabinets, have an IEC C13 connector on the end that plugs into the switch and an IEC C14 connector on the end that plugs into an IEC C13 outlet receptacle.



Note

Only the regular power cords or jumper power cords provided with the switch are supported.

[Table C-2](#) lists the power cords for the Cisco Nexus 6000 Series switches and provides their lengths in feet and meters. [Table C-3](#) lists the power cables for the HVAC/HVDC power supplies (NXA-PHV-1100W and NXA-PHV-1100W-B) that are available for the Cisco Nexus 6001 switch.

Table C-2 Power Cords for the Cisco Nexus 6000 Series Switches

Description	Length		Power Cord Reference Illustration
	Feet	Meters	
CAB-250V-10A-AR Power cord 250 VAC 10 A, IRAM 2073 plug Argentina	8.2	2.5	Figure C-1
CAB-9K10A-AU Power cord 250 VAC 10 A, 3112 plug, Australia	8.2	2.5	Figure C-2
CAB-250V-10A-CN Power cord 250 VAC 10 A, GB 2009 plug China	8.2	2.5	Figure C-3
CAB-9K10A-EU Power cord, 250 VAC 10 A, M 2511 plug Europe	8.2	2.5	Figure C-4
CAB250V-10A-ID Power cord 250 VAC 16A, EL-208 plug South Africa, United Arab Emirates, India	8.2	2.5	Figure C-5
CAB-250V-10A-IS Power cord 250 VAC 10 A, SI-32 plug Israel	8.2	2.5	Figure C-6
CAB-9K10A-IT Power cord 250 VAC 10 A, CEI 23-16 plug Italy	8.2	2.5	Figure C-7
CAB-9K10A-SW Power cord 250 VAC 10 A, MP232 plug Switzerland	8.2	2.5	Figure C-8

Table C-2 Power Cords for the Cisco Nexus 6000 Series Switches (continued)

Description	Length		Power Cord Reference Illustration
	Feet	Meters	
CAB-9K10A-UK Power cord 250 VAC 10 A, BS1363 plug (13 A fuse) United Kingdom	8.2	2.5	Figure C-9
CAB-AC-250V/13A Power cord 250 VAC 13 A, NEMA L6-20 plug North America	6.6	2.0	Figure C-10
CAB-N5K6A-NA Power cord 250 VAC 10 A, NEMA 6-15 plug North America	8.2	2.5	Figure C-11
CAB-9K12A-NA Power cord 125 VAC 13 A, NEMA 5-15 plug North America	8.2	2.5	Figure C-12
CAB-C13-CBN Power cord 250 VAC 10 A, SS 10A plug	8.2	2.5	Figure C-13
CAB-IND-10A Power cord 250 VAC 10 A, EL 208B plug	8.2	2.5	Figure C-14
CAB-C13-C14-JMPR Cabinet Jumper Power Cord 250 VAC 13 A, C13-C14 Connectors	2.2	0.7	Figure C-15

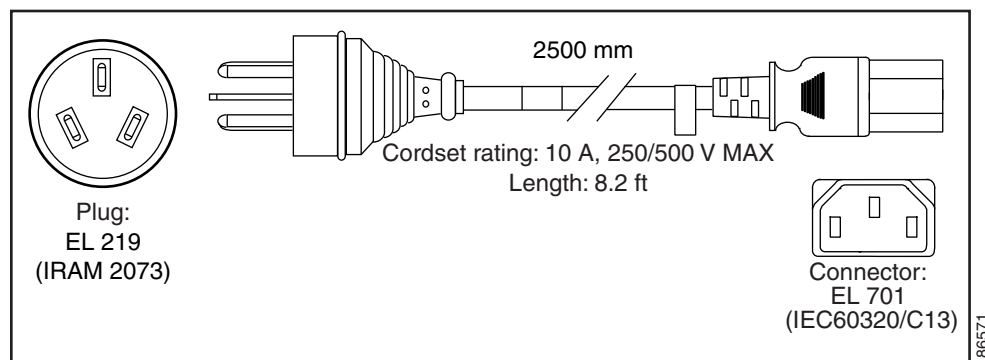
Figure C-1 SFS-250V-10A-AR

Figure C-2 CAB-9K10A-AU

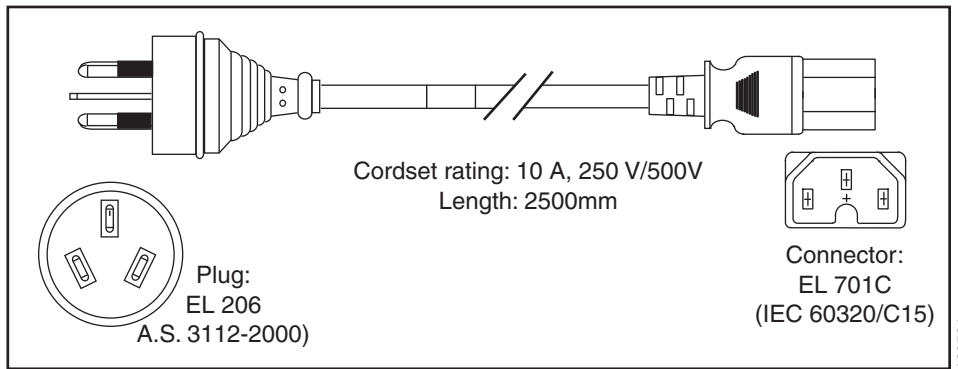


Figure C-3 SFS-250V-10A-CN

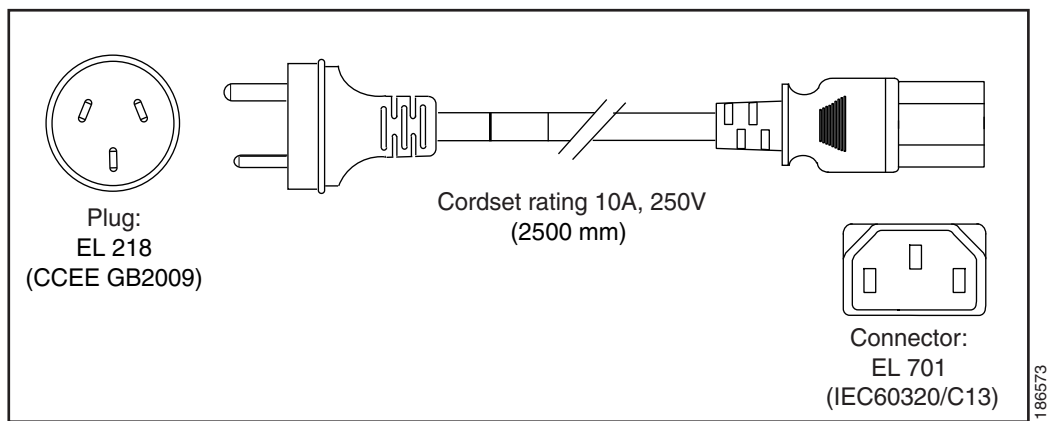


Figure C-4 CAB-9K10A-EU

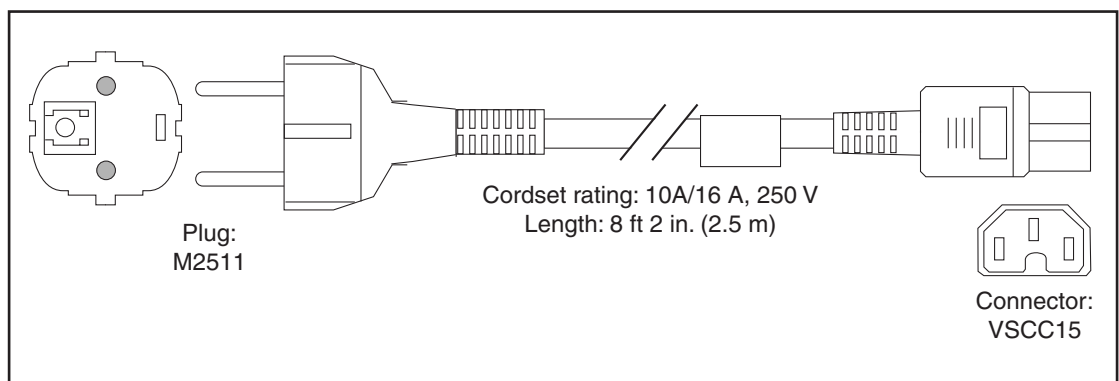
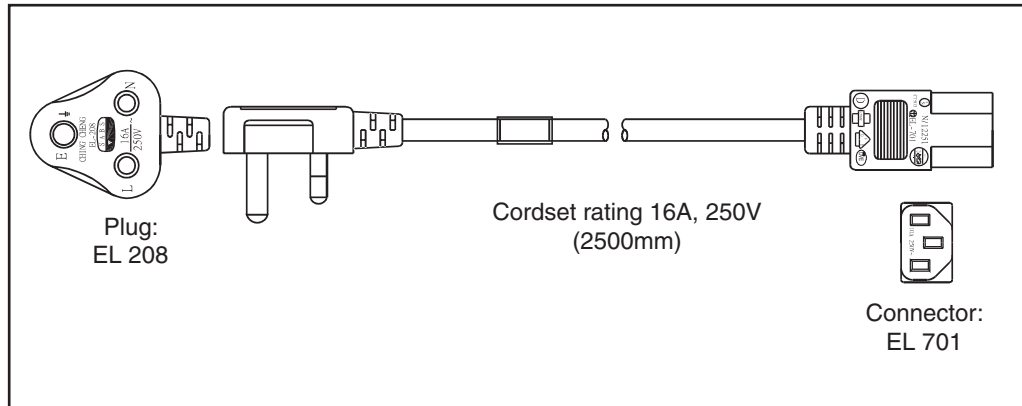
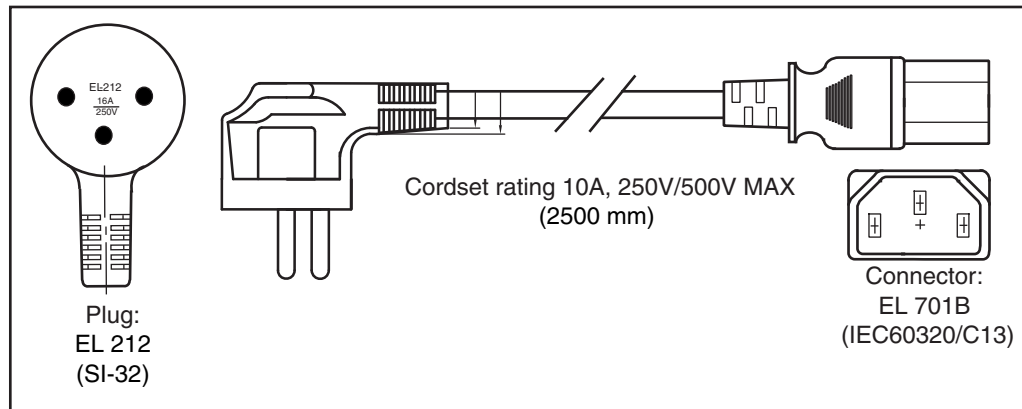


Figure C-5 SFS-250V-10A-ID



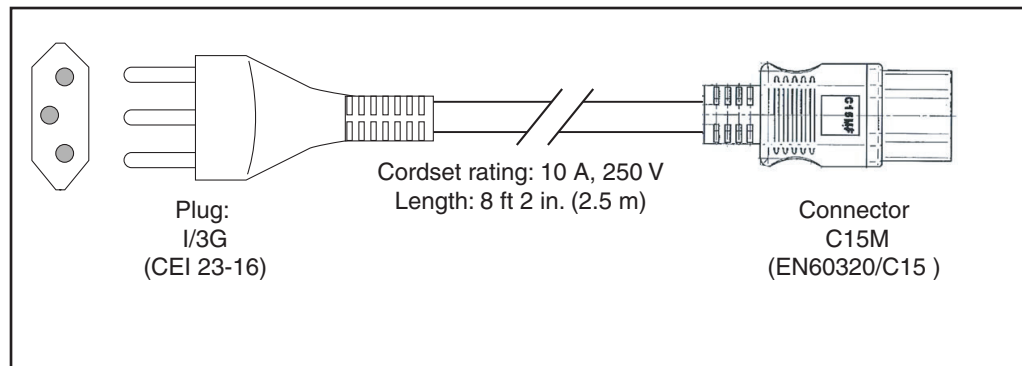
187490

Figure C-6 SFS-250V-10A-IS



186574

Figure C-7 CAB-9K10A-IT



186575

Figure C-8 CAB-9K10A-SW

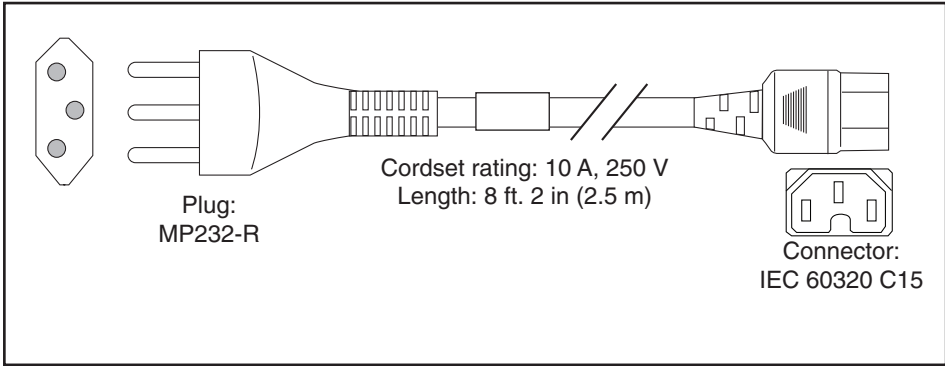


Figure C-9 CAB-9K10A-UK

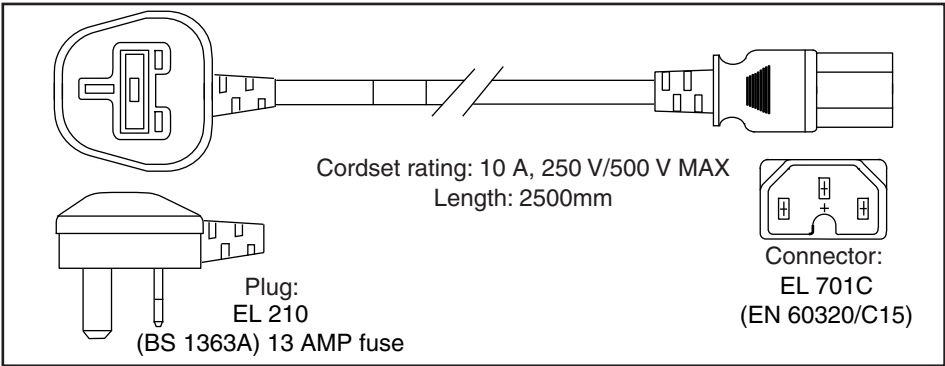


Figure C-10 CAB-AC-250V/13A

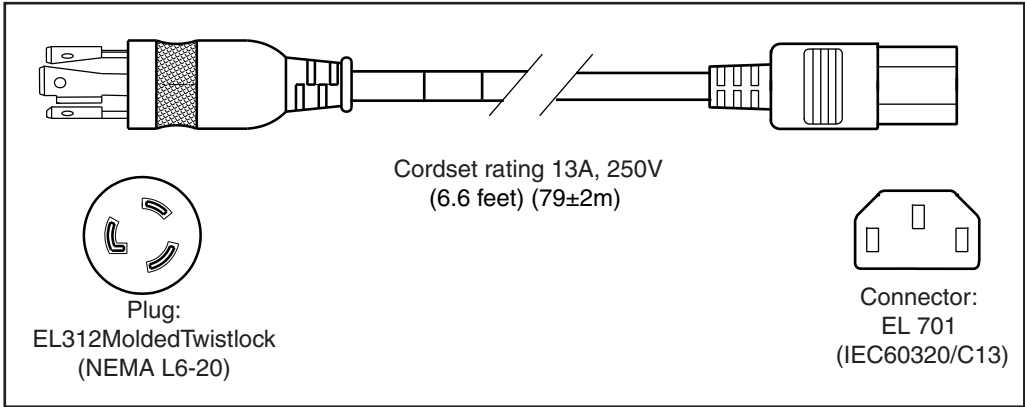


Figure C-11 CAB-N5K6A-NA

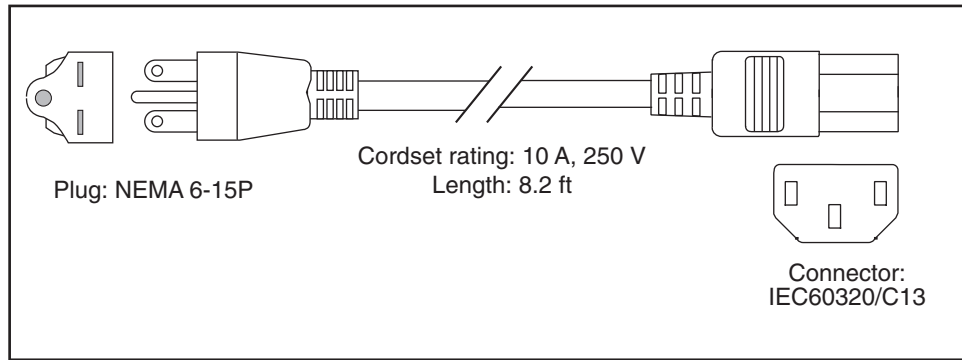


Figure C-12 CAB-9K12A-NA

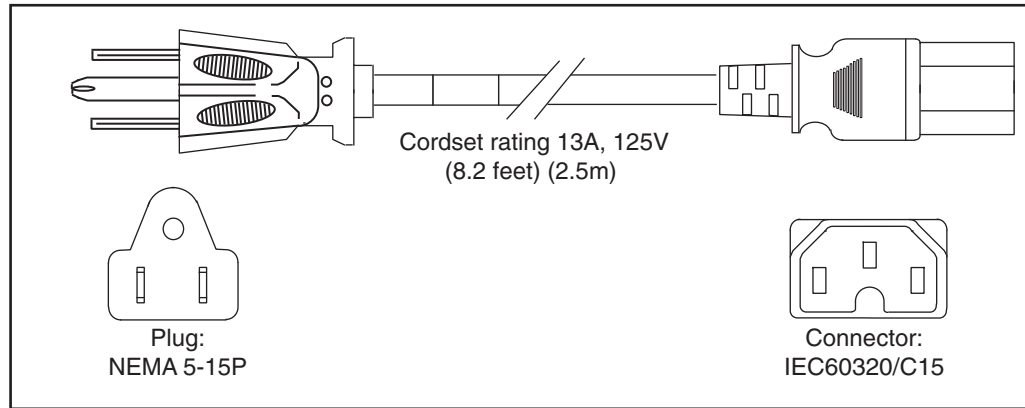


Figure C-13 CAB-C13-CBN

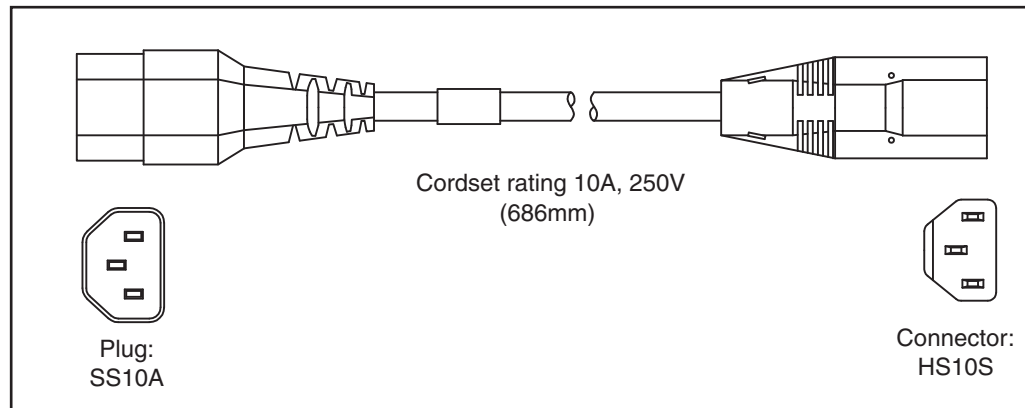


Figure C-14 CAB-IND-10A

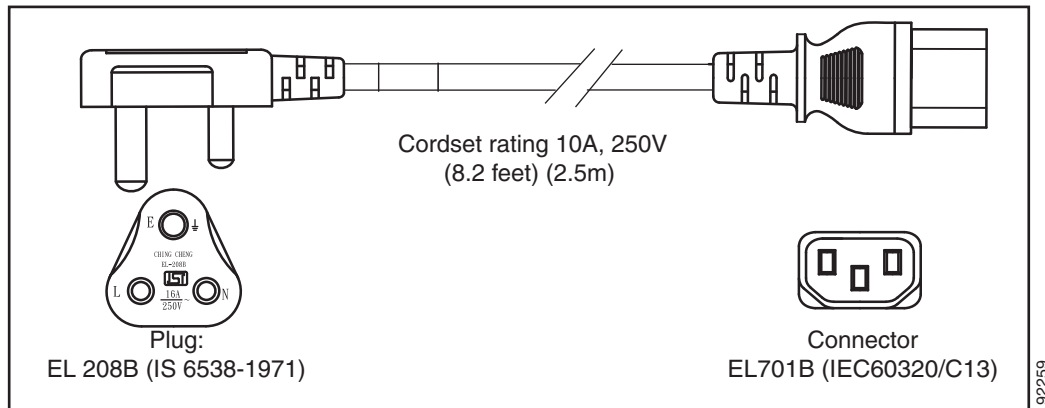


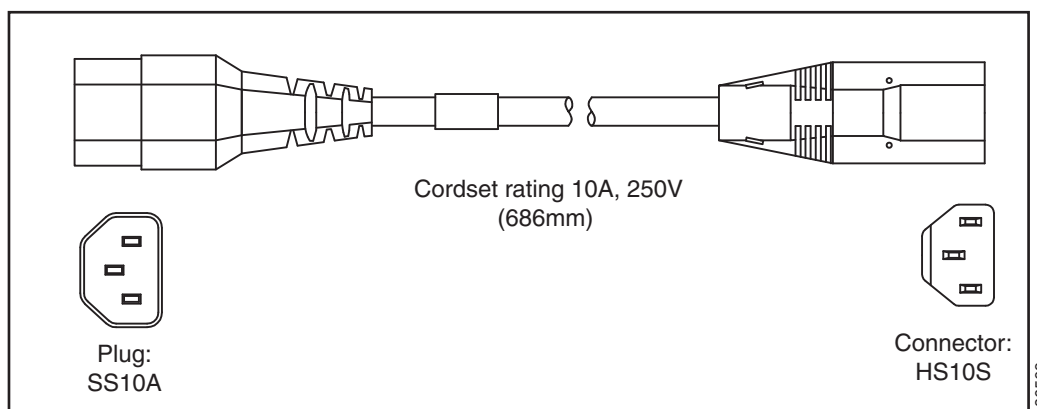
Table C-3 Power Cable Specifications for HVAC/HVDC Power Supplies

Power Type	Power Cord	Description
HVAC	CAB-HVAC-SD-0.6M	2-foot (0.6 m) cable with Saf-D-Grid and SD connectors (LS-25 straight)
HVAC	CAB-HVAC-C14-2M	6.6-foot (2.0 m) cable with Saf-D-Grid and C14 connector (use for up to 240 V)
HVAC	CAB-HVAC-RT-0.6M	2-foot (0.6 m) cable with Saf-D-Grid and RT connector (LS-25 right angle)
HVDC	CAB-HVDC-3T-2M	6.6-foot (2.0 m) cable with Saf-D-Grid and three terminal connectors

Jumper Power Cord

Figure C-15 shows the plug connector on the optional jumper power cord for the Cisco Nexus 6000 Series switches. This cable plugs into the power supply, and the receptacle of a power distribution unit for a cabinet. This cable comes in 6- and 9-foot (2- and 3-meter) lengths.

Figure C-15 CAB-C13-C14-JMPR, Jumper Power Cord





APPENDIX **D**

LEDs

This appendix describes the conditions indicated by the chassis and module LEDs on the Cisco Nexus 6000 Series switches.

This appendix includes the following sections:

- [Chassis and Module LEDs for the Cisco Nexus 6000 Series Switches, page D-1](#)
- [Port LEDs, page D-2](#)

Chassis and Module LEDs for the Cisco Nexus 6000 Series Switches

This section includes the following topics:

- [Chassis and Module LED Descriptions, page D-1](#)
- [Conditions Indicated by the Power Supply LEDs, page D-2](#)

Chassis and Module LED Descriptions

This table describes the chassis LEDs for the Cisco Nexus 6000 Series switches.

Indicator	Location	Function	Color	Status	State
Power LED	Front of Chassis	Chassis Power/Health	Green	Solid On	System is On and operating normally
				Off	Switch is powered off
			Amber	On	Fault condition
Fan Tray Status	Fan Trays (front)	Fan tray health indicator (multi-color)	Green	Solid On	Fan tray operating normally
			Amber	Solid On	Fan failure within the fan tray

Indicator	Location	Function	Color	Status	State
PSU Status Indicators	Power Supply (front)	PSU Health (multi-color)	Green	Off	No AC power to power supply
				Solid On	Power supply on and OK
			Amber	Solid On	Power supply failures, over voltage, over current, over temperature
				1 Hz blinking	AC present, 3.3VSB on, PSU is off
				Off	Operating normally
Chassis Locater	Front of Chassis	Identify selected chassis	Blue	Solid On	Chassis has been selected for locating
				Off	Chassis is not selected for locating

Table D-1 table describes the status of the two power supply LEDs

Conditions Indicated by the Power Supply LEDs

You can determine the power supply conditions by combining the LED states of the OK and FAIL LEDs (see Table D-1).

Table D-1 Power Supply LED Descriptions

Power Supply Condition	OK LED (Green)	FAIL LED (Amber)
No AC or DC power to all power supplies.	Off	Off
Power supply failure, including over voltage, over current, over temperature, and fan failure.	Off	On
Power supply warning events where the power supply continues to operate. These events include high temperature, high power, and slow fan.	Off	Blinking
AC present, 3.3 voltage standby (VSB) on, and the power supply unit is off. For a DC power supply, it indicates that DC power is present.	Blinking	Off
Power supply on and OK.	On	Off

Port LEDs

This section includes the following topics:

- [Ethernet Port LEDs, page D-3](#)
- [Ethernet and Fibre Channel LEDs, page D-3](#)

Ethernet Port LEDs

Table D-2 lists the LED descriptions for the RJ-45 Ethernet port LEDs.

Table D-2 Ethernet Port LED Descriptions

LED	Status	Description
Left	Off	No link
	Solid green	Physical link
Right	Off	No activity
	Blinking green	Activity

Ethernet and Fibre Channel LEDs

There are activity LED's per-port on the Cisco Nexus 6004 faceplate. The LEMs and GEMs have the same port level indicators as the fixed ports. Since 40G ports are comprised of 4x 10G ports, they will have 4x LEDs, one-LED-per-10G-port. Each LED represents the status of the 10G link within the 40G bundle, and follows the behavior in the table below. Table D-3 describes the behavior of the port LEDs.

Table D-3 Port-Level LEDs

Link State	LED State	Notes
Link Down	OFF	—
POST failed on port	AMBER_ON	—
Administrative down	OFF/AMBER_ON	Depending on the product you look at, the LED could be off, or solid amber
Link Up	GREEN_ON	Blinks based on network activity



Troubleshooting Hardware Components

This appendix describes how to identify and resolve problems that might occur with the hardware components of a Cisco Nexus 6000 Series switch.

This appendix includes the following sections:

- [Overview, page E-1](#)
- [Switch Hardware Best Practices, page E-1](#)
- [Power Supply Conditions, page E-2](#)

Overview

The key to success when troubleshooting the system hardware is to isolate the problem to a specific system component. The first step is to compare what the system is doing to what it should be doing. Because a startup problem can usually be attributed to a single component, it is more efficient to isolate the problem to a subsystem rather than troubleshoot each separate component in the system.

Problems with the initial power up are often caused by a module that is not firmly connected to the backplane or a power supply that has been disconnected from the power cord connector.

Overheating can also cause problems with the system, though typically only after the system has been operating for an extended period of time. The most common cause of overheating is the failure of a fan module.

Switch Hardware Best Practices

Use the recommendations in this section to ensure the proper installation, initialization, and operation of the switch.

This section includes the following topics:

- [Installation Best Practices, page E-2](#)
- [Initialization Best Practices, page E-2](#)
- [Switch Operation Best Practices, page E-2](#)

Installation Best Practices

When installing the switch, follow these best practices:

- Plan your site configuration and prepare the site before installing the chassis.
- Verify that you have the appropriate power supplies for your chassis configuration.
- Install the chassis following the rack and airflow guidelines presented in this guide.
- Verify that the chassis is adequately grounded.

Initialization Best Practices

When the initial system boot is complete, verify the following:

- Power supplies are supplying power to the system.
- Fan modules are operating normally.
- The system software boots successfully.

Switch Operation Best Practices

To ensure proper operation of your switch, take the following actions:

- Make a copy of the running configuration to CompactFlash for a safe backup.
- Always enter the **copy running-config startup-config** CLI command after you modify the running configuration and ensure that the system is operating properly.
- Never use the **init system** CLI command unless you understand that you will lose the running and startup configuration as well as the files stored on bootflash:.
- Keep backup copies of the running kickstart and the system images on CompactFlash.

Power Supply Conditions

The two LEDs on each power supply indicate the power status for each power supply. To determine the current status for a power supply unit, note which LED is on, blinking, or off and refer to [Table E-1](#).

Table E-1 Power Supply Conditions

Power Supply Condition	Power LED Status	Fail LED Status
No power to all power supplies.	Off	Off
Power supply failure, including overvoltage, overcurrent, overtemperature, and fan failure.	Off	On
Power supply warning events where the power supply continues to operate. These events include high temperature, high power, and slow fan.	Off	Blinking
AC present, 3.3 voltage standby (VSB) on, and the power supply unit is off.	Blinking	Off
Power supply on and OK.	On	Off



Accessory Kits

This appendix describes the contents of the accessory kits for the Cisco Nexus 6000 Series switches.

This appendix includes the following sections:

- [Cisco Nexus 6001 Switch Accessory Kit, page F-1](#)
- [Cisco Nexus 6004 Switch Accessory Kit, page F-1](#)

Cisco Nexus 6001 Switch Accessory Kit

This section describes the accessory kit contents for the Cisco Nexus 6001 switch accessory kit (N6K-C6001-ACC-KIT). The Cisco Nexus 6001 switch accessory kit includes the following items:

- 1 lower left rack-mount guide
- 1 lower right rack-mount guide
- 2 upper rack-mount guides
- 2 lower rack-mount sliders
- 2 upper rack-mount sliders
- 24 M4 x 0.7 x 8-mm Phillips flat-head screws
- 1 console cable with an RJ-45-RS-232 adapter and a DB9 adapter
- 1 ground lug kit
- 1 ESD wrist strap



Note

Additional parts can be ordered from your customer service representative.

Cisco Nexus 6004 Switch Accessory Kit

This section describes the accessory kit contents for the Cisco Nexus 6004 switch accessory kit (N6K-C6004-ACC-KIT)

The Cisco Nexus 6004 switch accessory kit includes the following items:

- 1 lower left rack-mount guide
- 1 lower right rack-mount guide

- 2 upper rack-mount guides
- 2 lower rack-mount sliders
- 2 upper rack-mount sliders
- 24 M4 x 0.7 x 8-mm Phillips flat-head screws
- 1 console cable with an RJ-45-RS-232 adapter and a DB9 adapter
- 1 ground lug kit
- 1 ESD wrist strap

**Note**

Additional parts can be ordered from your customer service representative.



Site Planning and Maintenance Records

This appendix provides log sheets that you can use to record information when installing a Cisco Nexus 6000 Series switch.

This appendix includes the following sections:

- [Site Preparation Checklist, page G-1](#)
- [Contact and Site Information, page G-3](#)
- [Chassis and Module Information, page G-4](#)

**Note**

For information about how to query the switch for configuration information, see the appropriate Cisco Nexus 6000 Series CLI configuration guide.

Site Preparation Checklist

Planning the location and layout of your equipment rack or wiring closet is essential for successful switch operation, ventilation, and accessibility. [Table G-1](#) lists the site planning tasks that we recommend completing before installing a Cisco Nexus 6000 Series switch.

Consider heat dissipation when sizing the air-conditioning requirements for an installation. See the environmental requirements, and the [“Power Specifications” section on page B-3](#) for power and heat ratings.

Table G-1 Site Planning Checklist

Task No.	Planning Activity	Verified By	Time	Date
1	Space evaluation: <ul style="list-style-type: none"> • Space and layout • Floor covering • Impact and vibration • Lighting • Maintenance access 			
2	Environmental evaluation: <ul style="list-style-type: none"> • Ambient temperature • Humidity • Altitude • Atmospheric contamination • Air flow 			
3	Power evaluation: <ul style="list-style-type: none"> • Input power type • Power receptacles¹ • Receptacle proximity to the equipment • Dedicated circuit for power supply • Dedicated (separate) circuits for redundant power supplies • UPS² for power failures 			
4	Grounding evaluation: <ul style="list-style-type: none"> • Circuit breaker size • CO ground (AC- powered systems) 			
5	Cable and interface equipment evaluation: <ul style="list-style-type: none"> • Cable type • Connector type • Cable distance limitations • Interface equipment (transceivers) 			
6	EMI ³ evaluation: <ul style="list-style-type: none"> • Distance limitations for signaling • Site wiring • RFI⁴ levels 			

1. Verify that the power supply installed in the chassis has a dedicated AC source circuit.

2. UPS = uninterruptible power supply.

3. EMI = electromagnetic interference.
4. RFI = radio frequency interference.

Contact and Site Information

Use the following worksheet ([Table G-2](#)) to record contact and site information.

Table G-2 **Contact and Site Information**

Contact person	
Contact phone	
Contact e-mail	
Building/site name	
Data center location	
Floor location	
Address (line 1)	
Address (line 2)	
City	
State	
Zip code	
Country	

Chassis and Module Information

Use the following worksheets (Table G-3 and Table G-4) to record information about the chassis and modules.

Contract Number _____

Chassis Serial Number _____

Product Number _____

Table G-3 Network-Related Information

Switch IP address	
Switch IP netmask	
Host name	
Domain name	
IP broadcast address	
Gateway/router address	
DNS address	
Modem telephone number	

Table G-4 Module Information

Slot	Module Type	Module Serial Number	Notes
1	Supervisor		
2			