



Cisco ASR 1000 Series Routers Hardware Overview

The Cisco ASR 1000 Series Aggregation Services Routers are the next generation midrange router products. The system is based on Cisco QuantumFlow Processor technology using a family of Cisco-developed processors.

The Cisco ASR 1000 Series Routers target both enterprise and service provider applications but with higher performance and improved availability. Applications covered by Cisco ASR 1000 Series Routers are:

- Enterprise applications—Intended as the mid-size aggregation and gateway router typically residing in a regional or large branch office:
 - WAN aggregation at Cisco Enterprise core
 - Internet gateway
 - Branch or regional office aggregation
 - Remote access aggregation
- Service provider applications—Intended as the low-end service provider edge and broadband aggregation device with similar throughput:
 - High-end customer premises equipment (CPE) for business-quality Internet access
 - Service provider leased line aggregation
 - Provider edge (PE) and high-end customer edge (CE) for Layer 2 VPN or Layer 3 VPN services
 - Broadband aggregation—PPPoE/PPPoA aggregation and Service Selection Gateway (SSG)
 - Low-end Ethernet aggregation

This chapter provides an overview of the Cisco ASR 1000 Series Routers and contains the following sections:

- [Cisco ASR 1000 Series Routers, on page 2](#)
- [Cisco ASR 1000 Series Router Features, on page 3](#)
- [Cisco ASR 1000 Series Routers Compatibility Information, on page 4](#)
- [Cisco ASR 1000 Series Router Configurations, on page 6](#)
- [Field-Replaceable Units, on page 7](#)
- [Functional Overview, on page 8](#)
- [Cisco Product Identification Standard, on page 16](#)

Cisco ASR 1000 Series Routers

The Cisco ASR 1000 Series Aggregation Services Routers are the next generation Cisco midrange router products. The Cisco ASR 1000 Series Aggregation Services Routers use an innovative and powerful hardware processor technology known as the Cisco QuantumFlow Processor. The following are the Cisco ASR 1000 Series Routers:

- The Cisco ASR 1006 Router is a 12-SPA, 6-rack-unit (RU), hardware-redundant chassis with two Embedded Services Processor (ESP) slots, two Route Processor (RP) slots, and three SIP slots.
- The Cisco ASR 1004 Router is an 8-SPA, four rack-unit (RU) chassis with one ESP slot, one RP slot, and two SIP slots.
- The Cisco ASR 1002 Router is a 3-SPA, 2-RU chassis with one embedded services processor slot that comes with the route processor, Cisco ASR 1000 Series Shared Port Adapter Interface Processor (SIP), and 4 Gigabit Ethernet ports built in. For more information about the type of connectors and cables used by the 4-port Gigabit Ethernet built-in SPA, the [Cisco ASR 1000 Series Aggregation Services Routers SIP and SPA Hardware Installation Guide](#).
- The Cisco ASR 1002-F Router is a one half-height SPA, 2-RU chassis. The embedded services processor, route processor, and SPA interface processor (SIP) are integrated with the chassis. In addition, 4 Gigabit Ethernet ports are built into the chassis.
- The Cisco ASR 1013 Router is a 24 half-height shared port adapters, 13-RU chassis that can hold 6 SIPs and provides superslots (more height and power) for the Cisco ASR1000-RP2s and Cisco ASR1000-ESPs. The Cisco ASR 1013 Router is designed with two zones (Zone 1 and Zone 0) for redundancy and superslot spacing. The Cisco ASR 1013 router has four 40G slots and two 100G slots.
- The Cisco ASR 1001 Router is a one rack-unit chassis that offers a compact form factor router that satisfies customer demands such as low power consumption and decreased usage of rack space. The Cisco ASR 1001 Router has the route processor, embedded services processor, and SIP integrated within the chassis with one half-height SPA slot.
- The Cisco ASR 1002-X Router is a 3-SPA, 2-RU chassis. The embedded services processor and route processor of this router are integrated in the chassis. There are six small form factor pluggable (SFP) Gigabit Ethernet ports. Depending on the Cisco software license that you install, the router can provide a forwarding bandwidth of 5 Gbps, 10 Gbps, 20 Gbps, or 36 Gbps.

For the single-route-processor Cisco ASR 1000 platforms (Cisco ASR 1002, Cisco ASR 1002-F, Cisco ASR 1002-X and Cisco ASR 1004), the route processor has a dual Cisco IOS Software option that allows these routers to use Cisco IOS software redundancy, Cisco high-availability features, and Nonstop Forwarding (NSF). Single-route-processor Cisco ASR 1000 platforms do not support ISSU upgrade or downgrade. Instead sub-package software upgrade is supported only if the router is running in sub-package mode.



Note The Software Redundancy feature requires the router to have 8 GB of DRAM memory.

The Cisco ASR 1000 Series Routers run Cisco IOS XE Software and introduce a distributed software architecture that moves many operating system responsibilities out of the IOS process. In this architecture, Cisco IOS, which previously was responsible for almost all of the internal software processes, now runs as one of many Cisco IOS XE processes while allowing other Cisco IOS XE processes to share responsibility for running the router.

The Cisco ASR 1000 Series Routers use the powerful Cisco QuantumFlow Processor which provides performance and resiliency for network processors.

The Cisco ASR 1000 Series Routers deliver multiple services embedded in the Cisco QuantumFlow Processor. The services supported on the Cisco Packet QuantumFlow Processor include security services (for example, encryption and firewall), quality of service (QoS), Network Based Application Recognition (NBAR), broadband aggregation, and session border controller, among others.

Cisco ASR 1000 Series Router Features

The Cisco ASR 1000 Series Aggregation Services routers use different field replaceable units:

- Cisco ASR 1000 Series route processor— Cisco ASR1000-RP1, ASR1000-RP2
- Cisco ASR 1000 Series embedded services processors (ESPs):
 - Cisco ASR1000-ESP5
 - Cisco ASR1000-ESP10
 - Cisco ASR1000-ESP20
 - Integrated Cisco ASR1002-ESP-F
 - Cisco ASR1000-ESP40
 - Cisco ASR1000-ESP100
 - Cisco ASR1000-ESP200
 - Cisco ESP-100X
 - Cisco ESP-200X



Note See xref Chapter 3, “Cisco ASR 1000 Series Routers Embedded Services Processors” for detailed information about Cisco ESPs.

-
- Cisco ASR 1000 SPA Interface Processors (SIPs):
 - Cisco ASR1000-SIP10
 - Cisco ASR1002-SIP10-F
 - Cisco ASR1000-SIP-40



Note See xref Chapter 4, “Cisco ASR 1000 Series Router SPA Interface Processors (SIPs)” for detailed information about Cisco SIPs.

Cisco ASR 1000 Series Routers provide the following features:

- Online insertion and removal (OIR) capability
- Route processor and embedded services processor redundancy in the Cisco ASR 1000 Series Routers (Cisco ASR 1013 Router and Cisco ASR 1006 Router)
- Control processor for ASR 1000 Series SPA Interface Processor
- Control processor for embedded services processors (Cisco ASR1000-ESP5, Cisco ASR1000-ESP10, Cisco ASR1000-ESP20, integrated Cisco ASR1002-ESP-F, Cisco ASR1000-ESP40, Cisco ASR1000-ESP100, and Cisco ASR1000-ESP200)
- 10 Gbps and 20 Gbps interconnect between Cisco QuantumFlow Processor with redundant Cisco ASR 1000 Series ESP to mirror data for stateful features

- Power supply redundancy
- Environmental monitoring and reporting functions
- Family of routers using common hardware and software architecture
- Centralized forwarding design (all network traffic passes through one engine)
- Front-to-back airflow—Allows you to mount the router from either front or back into 19-inch equipment rack
- Supports half-height shared port adapters (HHSPAs) and full-height shared port adapters (FHSPAs)



Note The Cisco ASR 1001 Router does not support full-height SPAs.

- Single midplane design (all connectors on one interface midplane)
- One 10/100/1000-Mbps Ethernet Management port—To be used only as a management port; not to be used as an Ethernet interface port
- Both quarter-rate (87.5 MHz) and full-rate (350 MHz) shared port adapter operation

The Cisco QuantumFlow Processor processing provides:

- Architecture to address Cisco ASR 1000 Series router performance, cost, power, and feature velocity
- Next Generation forwarding and queuing subsystems for Cisco routers to provide data path acceleration.

The Cisco ASR 1000 Series route processor system performs the following system management functions:

- Sending and receiving routing protocol updates
- Managing tables, caches, and buffers
- Monitoring interface and environmental status
- Providing Simple Network Management Protocol (SNMP) management through the console and Telnet interface
- Accounting for and switching of data traffic
- Booting and reloading images

Cisco ASR 1000 Series Routers Compatibility Information

The following table lists the Cisco ASR 1000 Series Routers configurations. It shows the combination of chassis, Cisco ASR1000-ESP, and Cisco ASR1000-SIP supported on the Cisco ASR 1000 Series Routers.

Table 1: ESP-100X and ESP-200X compatibility with Ethernet Line Cards and Carrier Cards

	ESP-100X	ESP-200X
ASR1000-SIP40	Yes	Yes
ASR1000-MIP100	Yes	Yes
ASR1000-6TGE	Yes	Yes
ASR1000-2T+20X1GE	Yes	Yes



Note The Cisco ASR 1001 Router supports Cisco ASR1000-ESP2.5 up to Cisco ASR1000-ESP5. The Cisco ASR 1002 Router, Cisco ASR 1002-F Router, and Cisco ASR 1002-X Router do not support Cisco ASR1000-ESP20, Cisco ASR1000-ESP40, Cisco ASR1000-ESP100, or Cisco ASR1000-RP2. Cisco ASR1000-ESP100 can be installed only on Cisco ASR 1006 and Cisco ASR 1013 routers. Cisco ASR1000-ESP200 can be installed only on Cisco ASR 1013 routers.

Hardware Compatibility

The following table lists the Cisco ASR 1000 Series Routers that support and are compatible with Cisco hardware products.

Table 2: Cisco ASR 1000 Series Routers and Component Compatibility and Support Matrix

Hardware Component	Cisco ASR 1013 Router	Cisco ASR 1006 Router	Cisco ASR 1004 Router	Cisco ASR 1002 Router and Cisco ASR 1002-F Router	Cisco ASR 1001 Router	Cisco ASR 1002-X Router
ASR1000-ESP5	Not compatible	Not compatible	Not supported	Supported	Not applicable	Not applicable
ASR1000-ESP10	Not compatible	Supported	Supported	Supported	Not applicable	Not applicable
ASR1000-ESP20	Not supported	Supported	Supported	Not compatible	Not applicable	Not applicable
ASR1000-ESP40	Supported	Supported	Supported	Not compatible	Not applicable	Not applicable
ASR1000-ESP100	Supported	Supported	Not compatible	Not compatible	Not applicable	Not applicable
ASR1000-ESP200	Supported	Not compatible	Not compatible	Not compatible	Not compatible	Not compatible
ASR1000-RP1	Not compatible	Supported	Supported	Not applicable	Not applicable	Not applicable
ASR1000-RP2	Supported	Supported	Supported	Not applicable	Not applicable	Not applicable
ASR1000-SIP10	Supported	Supported	Supported	Not applicable	Not applicable	Not applicable
ASR1000-SIP40	Supported	Supported	Supported	Not applicable	Not applicable	Not applicable
ASR1000 PEMs	ASR 1013 PEM supported	ASR 1013 PEM supported ASR 1006 PEM supported	ASR1004 PEM supported	ASR 1002 PEM supported	Supported with its own AC and DC power supplies	ASR 1002 PEM supported

The following is the outcome of upgrades performed using incompatible combinations of hardware components:

- The embedded services processor card is disabled and an error message is generated in either of the following scenarios:
 - Cisco ASR1000-ESP20, Cisco ASR1000-ESP40, or Cisco ASR1000-ESP100 is inserted in the Cisco ASR 1002 Router.

- Cisco ASR1000-ESP5 is inserted into Cisco ASR 1004 Router, Cisco ASR 1006 Router, or Cisco ASR 1013 Router.
- The Complex Programmable Logic Device (CPLD) field programmable upgrade for Cisco ASR1000-SIP10 cannot be performed in slot 5. Cisco ASR1000-SIP10 can be upgraded only in any one of the slots from slots 0 to 4.
- If Cisco ASR1000-RP1 is inserted into Cisco ASR 1013 Router, the card is disabled and an error message is generated

The Cisco ASR 1013 Router supports only the following components:

- Cisco ASR1000-RP2
- Cisco ASR1000-ESP40 or Cisco ASR1000-ESP200
- Cisco ASR1000-SIP10 or Cisco ASR1000-SIP40

Existing Cisco ASR1000-RP2 and Cisco ASR1000-SIP10 cannot be used as is in the Cisco ASR 1013 Router. These two components must be upgraded to support Cisco IOS XE Release 3.1S on the Cisco ASR 1013 Router.

Cisco ASR 1000 Series Router Configurations

The Cisco ASR 1000 Series Routers are available in different packaging configurations. Some of the chassis configurations are modular with separate field-replaceable units (FRUs) for the Cisco ASR 1000 Series Route Processors, the Cisco ASR 1000 Series Embedded Services Processors, and the shared port adapters.

All FRUs (Cisco ASR 1000 Series Route Processor 1, Cisco ASR 1000 Series Embedded Services Processor, and SPAs) are designed to work in the different chassis models. The power supplies and fan modules are chassis specific. The SPAs are supported in all chassis configurations although there are SPA restrictions in the Cisco ASR 1002 Router and the Cisco ASR 1002-F Router.

The following table lists the Cisco ASR 1000 Series Router configurations. In this table, HH is half height and FH is full height.

Table 3: Cisco ASR 1000 Series Router Product Family

Chassis	Number of ESP Slots	Maximum SPAs Supported	Number of RP Slots	Number of SIP Slots	Maximum Bandwidth
Cisco ASR 1001	Built-in ESP 2.5 Gbps/5 Gbps	1 HH Built-in ports 4 x 1GE SFP	One built-in 2.13GHz dual core Intel Xeon CPU	Fixed, SIP10	Up to 5 Gbps (with software license)
Cisco ASR 1013	2 superslots	24 HH	2 superslots	6	Up to 200 Gbps
Cisco ASR 1006	2	12 HH	2	3	Up to 100 Gbps
Cisco ASR 1004	1	8 HH	1	2	Up to 40 Gbps
Cisco ASR 1002	1	3 HH (1 built-in 4x1GE)	1 integrated (RP1)	1 integrated (SIP10)	Up to 10 Gbps
Cisco ASR 1002-F	1	1 HH (1 built-in 4x1 GE)	1 integrated (RP1)	1 integrated (SIP10)	Up to 2.5 Gbps

Chassis	Number of ESP Slots	Maximum SPAs Supported	Number of RP Slots	Number of SIP Slots	Maximum Bandwidth
Cisco ASR 1002-X	1	3 HH and 1 built-in 6x1 GE	1 integrated	1 integrated	Up to 36 Gbps (with software license)

Field-Replaceable Units

The Cisco ASR 1000 Series routers are easy to service; many of their major components are field-replaceable units (FRUs). The following are the Cisco ASR 1000 Series Router FRUs:

- Cisco ASR 1000 Series route processors: RP1 and RP2
- Cisco ASR 1000 Series embedded services processors: Cisco ASR1000-ESP5, Cisco ASR1000-ESP10, Cisco ASR1000-ESP20, Cisco ASR1000-ESP40, Cisco ASR1000-ESP100, and Cisco ASR1000-ESP200.
- Shared port adapters
- Cisco ASR 1000 Series shared port adapter interface processors (SIPs)
- Cisco ASR 1000 Series RP1 internal hard drive
- Cisco ASR 1000 Series RP1 DIMM memory module (Note that the integrated Cisco ASR1000-RP1 on the Cisco ASR 1002 Router DIMM memory module is not field-replaceable.)
- USB flash token memory stick
- AC and DC power supplies
- Bracket kit—Custom cable-management brackets are mounted to each rack-mount bracket to provide cable management to both sides of the chassis (parallel with card orientation). These brackets are screw-mounted to the rack brackets to enable easy installation and removal. There is a rack-mount bracket for each chassis:
 - For the Cisco ASR 1006 Router, the cable-management brackets contain five independent cable-management U features to provide cable dressing for each card module slot. For SIPs, these brackets work in tandem with SPA product feature cable management to allow installation and removal of adjacent cards without having to remove cables.
 - For the Cisco ASR 1004 Router, the cable-management brackets contain three independent cable-management U features to provide cable dressing for each card module slot. For SIPs, these brackets work in tandem with SPA product feature cable management to allow installation and removal of adjacent cards without having to remove cables.
 - For the Cisco ASR 1002 Router, the cable-management brackets contains one independent cable-management U feature to provide cable dressing for each card module slot. These brackets work in tandem with SPA product feature cable management to allow installation and removal of adjacent cards without having to remove cables.



Note The Cisco ASR 1002-F Router and Cisco ASR 1002-X Router use the same accessories as the Cisco ASR 1002 Router.

- For the Cisco ASR 1013 Router, the cable-management brackets contain four independent cable-management U features to provide cable dressing for modules. There are two brackets with four U-feature hooks for each side of the chassis.

- For the Cisco ASR 1001 Router, the cable-management bracket contains one independent cable-management U feature to provide cable dressing for each card module slot.

Functional Overview

This section contains the following topics:

Chassis Slot and Logical Interface Numbering

The Cisco ASR 1000 Series Routers have a slot numbering system located on both sides of the card module location. The chassis slots are physically numbered from zero starting at the bottom of the chassis. This section describes the slot numbering for the Cisco ASR 1000 Series Routers:

Cisco ASR 1000 Series SPA Interface Processor (SIP) subslots begin their numbering with “0” and have a horizontal orientation. The SIP subslot numbering is indicated by a small numeric label beside the subslot on the faceplate. Some commands allow you to display information about the SPA itself, such as **show idprom module** and **show hw-module subslot**. These commands require you to specify both the physical location of the SIP and SPA in the format, Slot/Subslot, where:

- Slot—Specifies the chassis slot number in the Cisco ASR 1000 Series Routers where the SIP is installed.
- Subslot—Specifies a subslot of the SIP where the SPA is installed.
- Superslots (power zone 0 and power zone 1)—Specifies the Cisco ASR 1013 Router slot spacing divided into zones.



Note See the router-specific chapter for chassis slot numbering and naming descriptions.

MAC Address Information

The *Media Access Control (MAC)* or *hardware* address is a standardized data link layer address that is required for certain network interface types. These addresses are specific and unique to each port and are not used by other devices in the network. The Cisco ASR 1000 Series Routers assign and control the MAC addresses of its shared port adapters.

You can identify shared port adapter slots by using software commands. To display information about:

- All shared port adapter slots, use the **show interfaces** command.
- A specific shared port adapter slot, use the **show interfaces** command with the shared port adapter type and slot number in the format **show interfaces port-adapter-type slot-number/port-number**.



Note If you abbreviate the command (**sh int**) and do not specify shared port adapter type and slot number (or arguments), the system interprets the command as **show interfaces** and displays the status of all shared port adapters and ports.

The MAC addresses are assigned to the slots in sequence. For example, in the Cisco ASR 1006 Router, the first address is assigned to slot 0 and the last address is assigned to slot 6. The actual MAC address assignment

is 16 MAC addresses per SPA slot for half-height SPAs and 64 per SPA slot for full-height SPAs. Also, the Cisco ASR 1000 Series RP1 RP Management Ethernet port is assigned one MAC address from the end of the pool and for the Cisco ASR 1006 Router with two Cisco ASR 1000 RP1s, each ASR10000 RP1 is assigned one MAC address.

Using this address scheme, you can remove shared port adapters and insert them into other routers without causing the MAC addresses to move around the network or be assigned to multiple devices.

If the MAC addresses were stored on each shared port adapter, online insertion and removal would not function because you could never replace one shared port adapter with an identical one; the MAC addresses would always be different. Also, each time a shared port adapter was replaced, other devices on the network would have to update their data structures with the new address. If the other devices did not update quickly enough, the same MAC address could appear in more than one device at the same time.



Note Storing the MAC addresses for every slot in one central location means the addresses stay with the memory device on which they are stored.

Online Insertion and Removal

In the modular chassis configurations, most Cisco ASR 1000 Series Router field-replaceable units (FRUs) support online insertion and removal (OIR). However, the removal of critical non-redundant FRUs will result in service interruption.



Note As you disengage the shared port adapter from the router, online insertion and removal (OIR) administratively shuts down all active interfaces in the shared port adapter.

Online insertion and removal (OIR) feature allows you to install and replace shared port adapters while the router is operating; you do not need to notify the software or shut down the system power, although you should not run traffic through the shared port adapter you are removing while it is being removed. Online insertion and removal is a method that is seamless to end users on the network, maintains all routing information, and preserves sessions.

All SPA OIR events are independent of one another. An OIR event of a single SPA does not affect the other SPAs in that ASR1000-SIP10 or any other system function.

The following items describe the OIR differences between the Cisco ASR 1002 Router, the Cisco ASR 1002-F Router, and the Cisco ASR 1002-X Router:

- The Cisco ASR 1002 Router supports the integrated Cisco ASR1000-RP1, which is a combined route processor and carrier card that are not field-replaceable units. The Cisco ASR1000-ESP5 or ASR1000-ESP10 are field-replaceable units.
- The Cisco ASR 1002-F Router supports an integrated route processor Cisco ASR1002-RP1 and an integrated embedded services processor Cisco ASR1000-ESP-F, which are not field-replaceable. The Cisco ASR1002-SIP10-F module is not removable; but the one half-height SPA is a field-replaceable unit.
- The Cisco ASR 1002-X Router supports an integrated route processor (Cisco ASR1002-RP2) and an integrated embedded services processor. Both these components are not field-replaceable. The router has a built-in 6x1GE SPA that occupies the SPA Bay 0. In addition, there are three half-height SPA bays for field-replaceable SPAs.

The following is a functional description of OIR for background information only; for specific procedures for installing and replacing a shared port adapter in Cisco ASR 1000 Series Routers, refer to the online configuration note for each shared port adapter.

When you remove or insert a shared port adapter in a Cisco ASR 1000 Series Router, the Control Processor notifies the Cisco ASR1000-RP1, which in turn notifies the forwarding engine control processor (FECP), and then performs the following steps:

- Rapidly scans the midplane for configuration changes.
- Initializes all newly inserted shared port adapters, noting any removed interfaces and placing them in the administratively shutdown state.
- Brings all previously configured interfaces on the shared port adapter back to the state they were in when they were removed. Any newly inserted interfaces are put in the administratively shutdown state, as if they were present (but not configured) at boot time. If a similar shared port adapter type is reinserted into a slot, its ports are configured and brought online up to the port count of the original SPA.

Environmental Monitoring and Reporting Functions

Environmental monitoring and reporting functions allow you to maintain normal system operation by identifying and resolving adverse conditions prior to loss of operation.



Caution

To prevent overheating the chassis, ensure that your system is drawing cool inlet air. Over temperature conditions can occur if the system is drawing in the exhaust air of other equipment. Ensure adequate clearance around the sides of the chassis so that cooling air can flow through the chassis interior unimpeded and exhaust air exits the chassis and is not drawn into the inlet vent of another device.

Environmental Monitoring

The environmental monitoring functions use sensors to monitor the temperature of the cooling air as it moves through the chassis.

The local power supplies provide the ability to monitor:

- Input and output voltage
- Output current
- Outlet temperature

The Cisco ASR 1000 Series Routers are expected to meet the following environmental operating conditions:

- Operating Temperature Nominal: 5° to 40°C
- Operating Temperature Short Term: -5° to +55°C (not applicable to the Cisco ASR 1001 Router)
- Operating Humidity Nominal: 5% to 85% noncondensing
- Operating Humidity Short Term: 5% to 90% noncondensing (not applicable to the Cisco ASR 1001 Router)
- Operating Altitude: 198 to 13,200 feet (60 to 4000 meters)
- DC Input Range: -40.5 to -72 VDC
- AC Input Range: 85 to 264 VAC

If the air temperature exceeds a defined threshold, the system controller displays warning messages on the console terminal, and if the temperature exceeds the shutdown threshold, the system controller shuts down the system.

In addition, the power supplies monitor internal power supply temperatures and voltages. A power supply is either within tolerance (normal) or out of tolerance (critical). If an internal power supply temperature or voltage reaches a critical level, the power supply shuts down without any interaction with the system processor.

The environmental monitoring functions use the following levels of status conditions to monitor the system:

- Normal—All monitored parameters are within normal tolerances.
- Warning—The system has exceeded a specified threshold. The system continues to operate, but operator action is recommended to bring the system back to a normal state.
- Critical—An out-of-tolerance temperature or voltage condition exists. The system continues to operate; however, the system is approaching shutdown. Immediate operator action is required.
- Shutdown—The processor has detected a temperature condition that could result in physical damage to system components and has disabled DC power to all internal components. This condition requires immediate operator action. All DC power remains disabled until you toggle the power switch. Before any shutdown, the system logs the status of monitored parameters in NVRAM so you can retrieve it later to help determine the cause of the problem.
- Power supply shutdown—The power supply detected an internal out-of-tolerance overvoltage, overcurrent, or temperature condition and shut itself down. All DC power remains disabled until you toggle the power switch.

Fan Failures

When the system power is on, all fans should be operational. The system continues to operate if a fan fails. When a fan fails, the system displays the following message:

```
router: 00:03:46:%ENVM-3-BLOWER:Fan 2 may have failed
```

If the air temperature exceeds a defined threshold, the system controller displays warning messages on the console terminal, and if the temperature exceeds the shutdown threshold, the system controller shuts down the system.

If the system does shut down because the temperature exceeded the shutdown threshold, the system displays the following message on the console screen and in the environment display when the system restarts:

```
Queued messages:  
%ENVM-1-SHUTDOWN: Environmental Monitor initiated shutdown
```

Reporting Functions

The chassis manager on the forwarding engine control processor manages the local resources of the forwarding processor. It manages the ESI (Enhanced Serdes Interconnect) which are the datapath links on the midplane connecting the Cisco ASR 1000 Series RP1s, SIPs, and standby ESP modules to the active Cisco ASR 1000 Series Embedded Services Processor. It communicates with the chassis manager on the Cisco ASR 1000 Series Route Processor 1 to report the status and health, including detected hardware failures, ESI status, software process status, and the state of thermal sensors.

The Cisco ASR 1000 Series Routers display warning messages on the console if the chassis interface-monitored parameters exceed a threshold. You can also retrieve and display environmental status reports with the following commands:

- **show environment all**
- **show version**
- **show inventory**
- **show platform**

- **show platform software status control-processor**
- **show diag**

Parameters are measured and reporting functions are updated every 60 seconds. A brief description of each of these commands follows.



Note The example outputs displayed in this section are from the Cisco ASR 1004 Router. Similar output is displayed for all Cisco ASR 1000 Series Routers.

```
Router# show environment all
Sensor List: Environmental Monitoring
Sensor      Location      State      Reading
V1: VMA     F0            Normal     1791 mV
V1: VMB     F0            Normal     1196 mV
V1: VMC     F0            Normal     1191 mV
V1: VMD     F0            Normal     1093 mV
V1: VME     F0            Normal     996 mV
V1: 12v     F0            Normal     11894 mV
V1: VDD     F0            Normal     3261 mV
V1: GP1     F0            Normal     900 mV
V2: VMA     F0            Normal     3286 mV
V2: VMB     F0            Normal     2495 mV
V2: VMC     F0            10% high   1796 mV
V2: VMD     F0            Normal     1093 mV
V2: VME     F0            Normal     996 mV
V2: VMF     F0            Normal     996 mV
V2: 12v     F0            Normal     11850 mV
V2: VDD     F0            Normal     3261 mV
V2: GP1     F0            10% high   898 mV
Temp: Inlet F0            Normal     29 Celsius
Temp: Asic1 F0            Normal     47 Celsius
Temp: Exhaust1 F0          Normal     36 Celsius
Temp: Exhaust2 F0          Normal     36 Celsius
Temp: Asic2 F0            Normal     43 Celsius
V1: VMA     0             Normal     1093 mV
V1: VMB     0             Normal     1196 mV
V1: VMC     0             Normal     1494 mV
V1: VMD     0             Normal     1791 mV
V1: VME     0             Normal     2490 mV
V1: VMF     0             Normal     3291 mV
V1: 12v     0             Normal     11894 mV
V1: VDD     0             Normal     3266 mV
V1: GP1     0             Normal     747 mV
V1: GP2     0             Normal     898 mV
V2: VMA     0             20% low    0 mV
V2: VMB     0             Normal     1201 mV
V2: VMC     0             20% low    0 mV
V2: VMD     0             20% low    0 mV
V2: VME     0             20% low    0 mV
V2: VMF     0             20% low    0 mV
V2: 12v     0             Normal     11909 mV
V2: VDD     0             Normal     3271 mV
V2: GP2     0             Normal     903 mV
Temp: Left  0             Normal     25 Celsius
Temp: Center 0             Normal     26 Celsius
Temp: Asic1 0             Normal     36 Celsius
Temp: Right 0             Normal     23 Celsius
PEM Iout   P0            Normal     17 A
PEM Vout   P0            Normal     12 V AC
```

PEM Vin	P0	Normal	115 V AC
Temp: PEM	P0	Normal	27 Celsius
Temp: FC	P0	Fan Speed 65%	26 Celsius
Temp: FM	P1	Normal	24 Celsius
Temp: FC	P1	Fan Speed 65%	26 Celsius
V1: VMA	R0	Normal	1098 mV
V1: VMB	R0	Normal	3295 mV
V1: VMC	R0	Normal	2495 mV
V1: VMD	R0	Normal	1791 mV
V1: VME	R0	Normal	1499 mV
V1: VMF	R0	Normal	1201 mV
V1: 12v	R0	Normal	11938 mV
V1: VDD	R0	Normal	3261 mV
V1: GP1	R0	Normal	903 mV
V1: GP2	R0	Normal	1242 mV
Temp: CPU	R0	Normal	33 Celsius
Temp: Outlet	R0	Normal	32 Celsius
Temp: Inlet	R0	Normal	26 Celsius
Temp: Asic1	R0	Normal	32 Celsius

The **show version** command displays the system hardware configuration, software version, and names and sources of configuration files and boot images.

The following is sample output of the **show version** command:

```
Router# show version
Cisco IOS Software, IOS-XE Software (PPC_LINUX_IOSD-ADVENTERPRISEK9-M), Version 12.2(33)XNA,
  RELEASE SOFTWARE
Technical Support: http://www.cisco.com/techsupport
Copyright (c) 1986-2008 by Cisco Systems, Inc.
Compiled Thu 01-May-08 00:29 by mcpre
Cisco IOS-XE software, Copyright (c) 1986-2008 by Cisco Systems, Inc.
All rights reserved. Certain components of Cisco IOS-XE software are
licensed under the GNU General Public License (GPL) Version 2.0. The
software code licensed under GPL Version 2.0 is free software that comes
with ABSOLUTELY NO WARRANTY. You can redistribute and/or modify such
GPL code under the terms of GPL Version 2.0. For more details, see the
documentation or License Notice file accompanying the IOS-XE software,
or the applicable URL provided on the flyer accompanying the IOS-XE
software.
A summary of U.S. laws governing Cisco cryptographic products may be found at:
http://www.cisco.com/wwl/export/crypto/tool/stqrg.html

If you require further assistance please contact us by sending email to
export@cisco.com.
cisco ASR1004 (RP1) processor with 757182K/6147K bytes of memory.
2 Packet over SONET interfaces
32768K bytes of non-volatile configuration memory.
2097152K bytes of physical memory.
439807K bytes of eUSB flash at bootflash:.
39004543K bytes of SATA hard disk at harddisk:.

Configuration register is 0x0
```

The **show inventory** command displays an extended report that includes the product inventory listing of all Cisco products installed in the networking device.

The following is sample output of the **show inventory** command:

```
Router# show inventory
NAME: Chassis, DESCR: Cisco ASR1004 Chassis
PID: ASR1004          , VID: V00, SN:
```

```

NAME: module 0, DESCR: Cisco ASR1000 SPA Interface Processor 10
PID: MCP-CC , VID: V00, SN: JAB1104064G

NAME: SPA subslot 0/1, DESCR: 2-port OC3/STM1 POS Shared Port Adapter
PID: SPA-2XOC3-POS , VID: V01, SN: JAB1006095Z

NAME: subslot 0/1 transceiver 0, DESCR: OC3 SR-1/STM1 MM
PID: N/A , VID: , SN: 2008692

NAME: SPA subslot 0/2, DESCR: 4-port T3/E3 Serial Shared Port Adapter
PID: SPA-4XT3/E3 , VID: V01, SN: JAB09210247

NAME: module R0, DESCR: Cisco ASR1000 Route Processor 1
PID: ASR1000-RP1 , VID: V00, SN: JAB110200CQ

NAME: module F0, DESCR: Cisco ASR1000 Embedded Services Processor, 10Gbps
PID: ASR1000-ESP10 , VID: V00, SN: JAB111101A1

NAME: Power Supply Module 0, DESCR: Cisco ASR1004 AC Power Supply
PID: ASR1004-PWR-AC , VID: V00, SN: ART1103K00C

NAME: Fan Module 1, DESCR: Cisco ASR1004 Fan Module
PID: ASR1004-FAN , VID: V00, SN: ART1052L01U

```

The **show platform** command displays platform information.

The following is sample output of the **show platform** command:

```

Router# show platform
Chassis type: ASR1004

Slot      Type                State                Insert time (ago)
-----
0         MCP-CC              ok                  16:20:27
0/1      SPA-2XOC3-POS      ok                  16:18:49
0/2      SPA-4XT3/E3        ok                  16:18:56
R0       ASR1000-RP1        ok, active          16:20:27
F0       ASR1000-ESP10      ok, active          16:20:27
P0       ASR1004-PWR-AC     ok                  16:19:27
P1       ASR1004-FAN        ok                  16:19:27

Slot      CPLD Version        Firmware Version
-----
0         07091401            12.2(33r)XN1
R0       0706210B            12.2(33r)XN1
F0       07051650            12.2(33r)XN1

```

The **show platform software status control-processor** command displays the average load, memory usage, and CPU utilization levels at which the router is running. The output also specifies whether the levels of these system health parameters are within defined thresholds.

The following is sample output of the **show platform software status control-processor** command:

```

Router# show platform software status control-processor
RP0: online, statistics updated 4 seconds ago
Load Average: healthy
  1-Min: 0.00, status: healthy, under 5.00
  5-Min: 0.00, status: healthy, under 5.00
 15-Min: 0.00, status: healthy, under 5.00
Memory (kb): healthy
  Total: 8133932
  Used: 1754156 (21%), status: healthy, under 90%
  Free: 6379776 (78%), status: healthy, over 10%

```

```

    Committed: 5059032 (62%), status: healthy, under 90%
Per-core Statistics
CPU0: CPU Utilization (percentage of time spent)
    User: 0.09, System: 0.00, Nice: 0.00, Idle: 99.80
    IRQ: 0.09, SIRQ: 0.00, IOWait: 0.00
CPU1: CPU Utilization (percentage of time spent)
    User: 0.00, System: 0.00, Nice: 0.00, Idle:100.00
    IRQ: 0.00, SIRQ: 0.00, IOWait: 0.00
ESP0: online, statistics updated 8 seconds ago
Load Average: healthy
    1-Min: 0.02, status: healthy, under 5.00
    5-Min: 0.02, status: healthy, under 5.00
    15-Min: 0.00, status: healthy, under 5.00
Memory (kb): healthy
    Total: 3895500
    Used: 547868 (13%), status: healthy, under 90%
    Free: 3347632 (81%), status: healthy, over 10%
    Committed: 2509772 (60%), status: healthy, under 300%
Per-core Statistics
CPU0: CPU Utilization (percentage of time spent)
    User: 1.20, System: 2.10, Nice: 0.00, Idle: 96.70
    IRQ: 0.00, SIRQ: 0.00, IOWait: 0.00
SIP0: online, statistics updated 7 seconds ago
Load Average: healthy
    1-Min: 0.01, status: healthy, under 5.00
    5-Min: 0.02, status: healthy, under 5.00
    15-Min: 0.00, status: healthy, under 5.00
Memory (kb): healthy
    Total: 483592
    Used: 366728 (69%), status: healthy, under 90%
    Free: 116864 (22%), status: healthy, over 10%
    Committed: 365968 (69%), status: healthy, under 90%
Per-core Statistics
CPU0: CPU Utilization (percentage of time spent)
    User: 0.40, System: 0.50, Nice: 0.00, Idle: 99.10
    IRQ: 0.00, SIRQ: 0.00, IOWait: 0.00
SIP1: online, statistics updated 6 seconds ago
Load Average: healthy
    1-Min: 0.00, status: healthy, under 5.00
    5-Min: 0.01, status: healthy, under 5.00
    15-Min: 0.00, status: healthy, under 5.00
Memory (kb): healthy
    Total: 483592
    Used: 351388 (67%), status: healthy, under 90%
    Free: 132204 (25%), status: healthy, over 10%
    Committed: 365840 (69%), status: healthy, under 90%
Per-core Statistics
CPU0: CPU Utilization (percentage of time spent)
    User: 1.80, System: 2.50, Nice: 0.00, Idle: 95.59
    IRQ: 0.00, SIRQ: 0.10, IOWait: 0.00

```

The **show diag slot R0 eeprom detail** command displays the configuration hardware information including DRAM and Static RAM (SRAM) on line cards. To display more details than the normal **show diag slot R0 eeprom detail** command output, use **show diag [slot-number] [details]**.

The following is sample output of the **show diag slot R0 eeprom detail** command:

```

Router# show diag slot R0 eeprom detail

Slot R0 EEPROM data:

EEPROM version : 4
Compatible Type : 0xFF
Controllor Type : 1460

```

```

Hardware Revision : 4.7
PCB Part Number : 73-10253-04
Board Revision : 03
Deviation Number : 0-0
Fab Version : 04
PCB Serial Number : JAB110200CQ
RMA Test History : 00
RMA Number : 0-0-0-0
RMA History : 00
Top Assy. Part Number : 68-2625-04
Product Identifier (PID) : ASR1000-RP1
CLEI Code : UNASSIGNED
Version Identifier (VID) : V00
Manufacturing Test Data : 00 00 00 00 00 00 00 00 00
Field Diagnostics Data : 00 00 00 00 00 00 00 00 00
Asset ID : AAAAAAAAAAAAAAAAAAAAAAAAAAAAAAAAAA

```

Cisco Product Identification Standard

This section describes the Cisco products and services product identification standard. This feature provides you with the ability to effectively integrate and manage Cisco products in your network and business operations.

Unique Device Identifier

The Unique Device Identifier (UDI) is the Cisco product identification standard for hardware products. A product identification standard removes barriers to enterprise automation and can help you reduce operating expenses.

The UDI provides a consistent electronic, physical, and associated business-to-business information product identification standard.

The UDI is a combination of five data elements. The following table lists the UDI elements.

Table 4: Cisco UDI Elements

UDI Data Element	Electronic Visibility	Physical Visibility	Description
PID	Yes	Yes	Product ID, also known as product name, model name, product number
VID	Yes	Yes	Version ID
SN	Yes	Yes	Serial number, the unique instance of the PID (see xref Figure 1-1, Figure 1-2, Figure 1-3, Figure 1-4, Figure 1-5, and Figure 1-6 in the next section for location of the serial number label)
Entity Name	Yes	No	Type, such as chassis, slot, or power supply
Product Description	Yes	No	Additional product information

The combination of serial number and product ID (PID) is unique and consistent across all Cisco products. The PID that is coded on hardware is called a base product identifier.

Additional orderable PIDs may be associated to a base PID. For instance, an orderable PID may describe a packaging configuration for a product or a bundled group of products sold, tested, and shipped together. Specific unique device identifier (UDI) benefits include the following:

- Identifies:
 - Individual Cisco products in your networks
 - PIDs and SNs for service and replaceable products
 - VIDs for product version visibility
- Facilitates discovery of products subject to recall or upgrade
- Enhances inventory automation of Cisco products

The Cisco product identification standard provides the following features:

- Version visibility—Cisco continuously improves products through feature additions. Product changes are indicated by incrementing the version ID (VID), which provides version visibility to help you understand and manage product changes. The VID management ensures consistency of changes from product to product.
- Operating expense reduction— The Cisco UDI provides accurate and detailed network inventory information; identifying each Cisco product in a network element through a standard interface. Cisco operating systems can view and use this data, allowing you to automate your electronic inventory.
- Consistency across product layers—The UDI is designed into hardware products and cannot be overwritten in error. Operating and management systems discover the UDI through standard interfaces and display the UDI in standard outputs. Standard interfaces include the IETF standard ENTITY-MIB.



Note Go to the following URL for complete information on the product identification standard:
<http://www.cisco.com/go/udi/>

Serial Number Label Location

This section contains graphics of each chassis showing the location of the serial number label:

The following figure shows the serial number location for the Cisco ASR 1006 Router.

Figure 1: Cisco ASR 1006 Router Serial Number Label Location

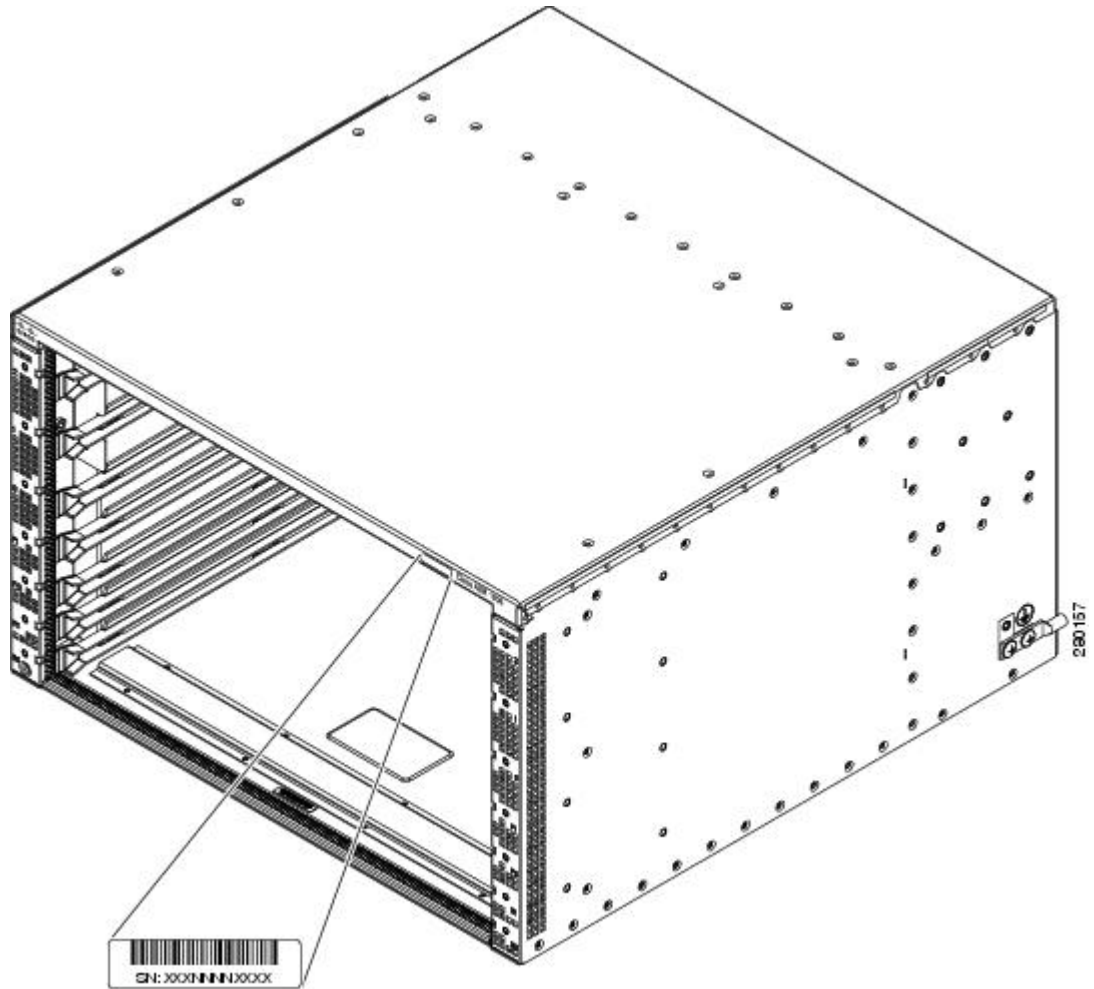

The following figure shows the serial number label location for the Cisco ASR 1002 Router.

Figure 2: Cisco ASR 1002 Router Serial Number Label Location

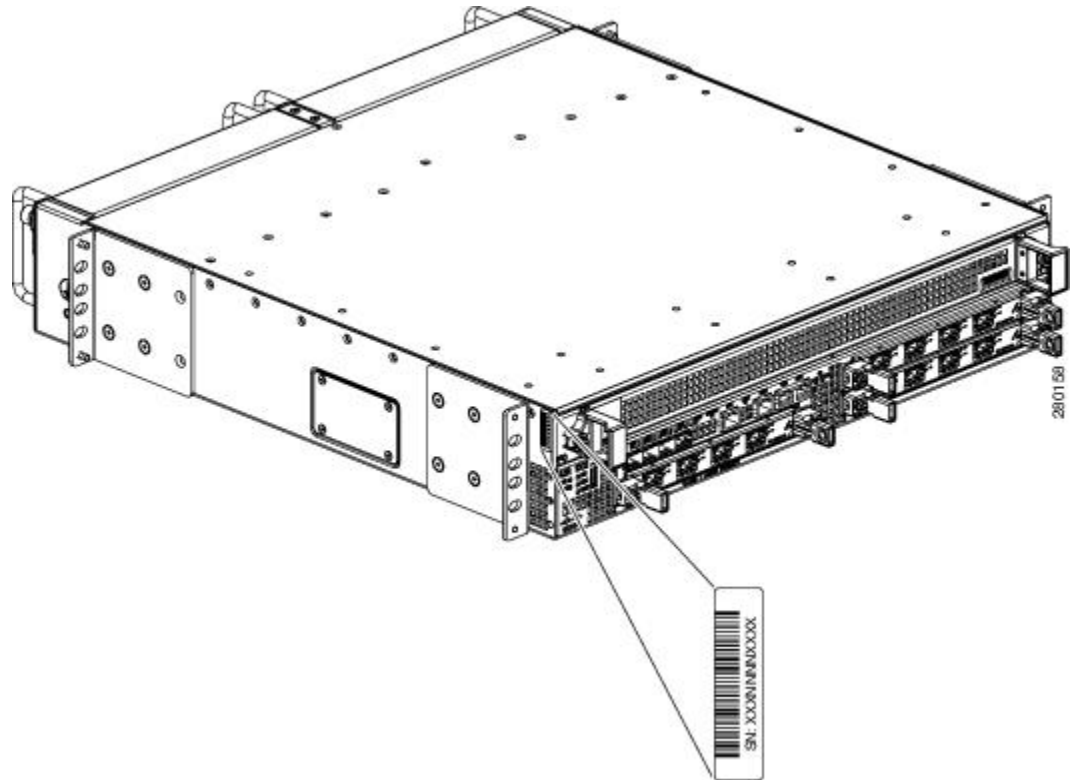

The following figure shows the serial number label location for the Cisco ASR 1002-F Router.

Figure 3: Cisco ASR 1002-F Router Serial Number Label Location

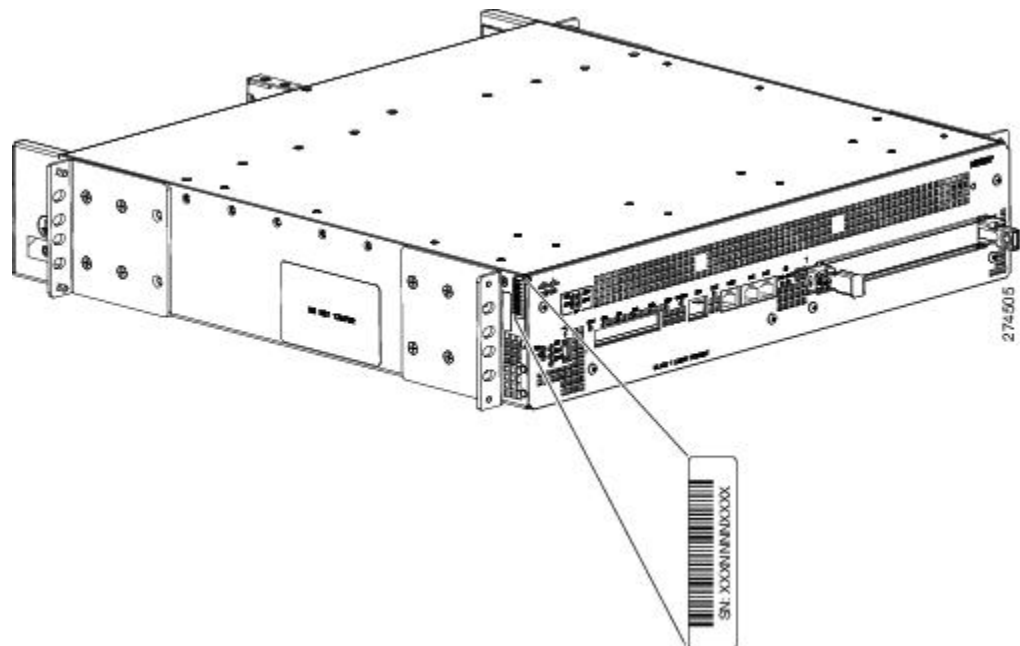

The following figure shows the serial number label location for the Cisco ASR 1013 Router (Note that this is the bottom of the chassis).

Figure 4: Cisco ASR 1013 Router Serial Number Label Location

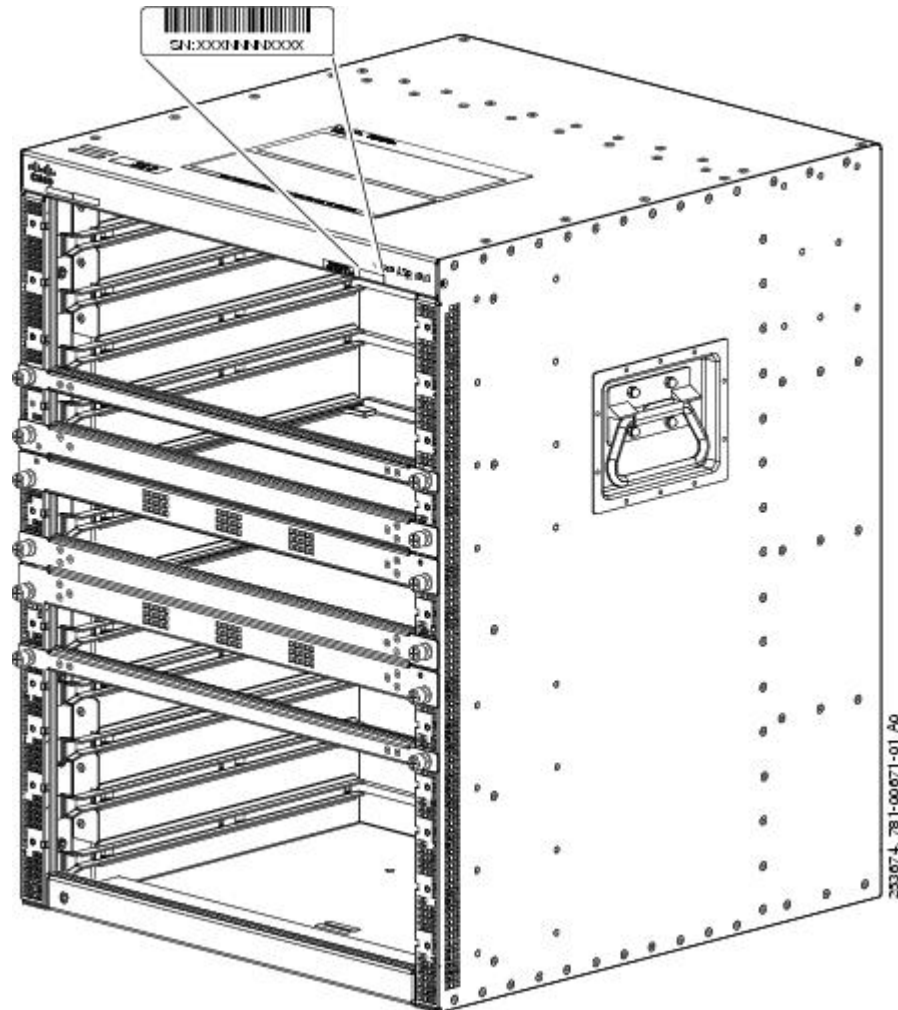

The following figure shows the serial number label location for the Cisco ASR 1001 Router.

Figure 5: Cisco ASR 1001 Router Serial Number Label Location

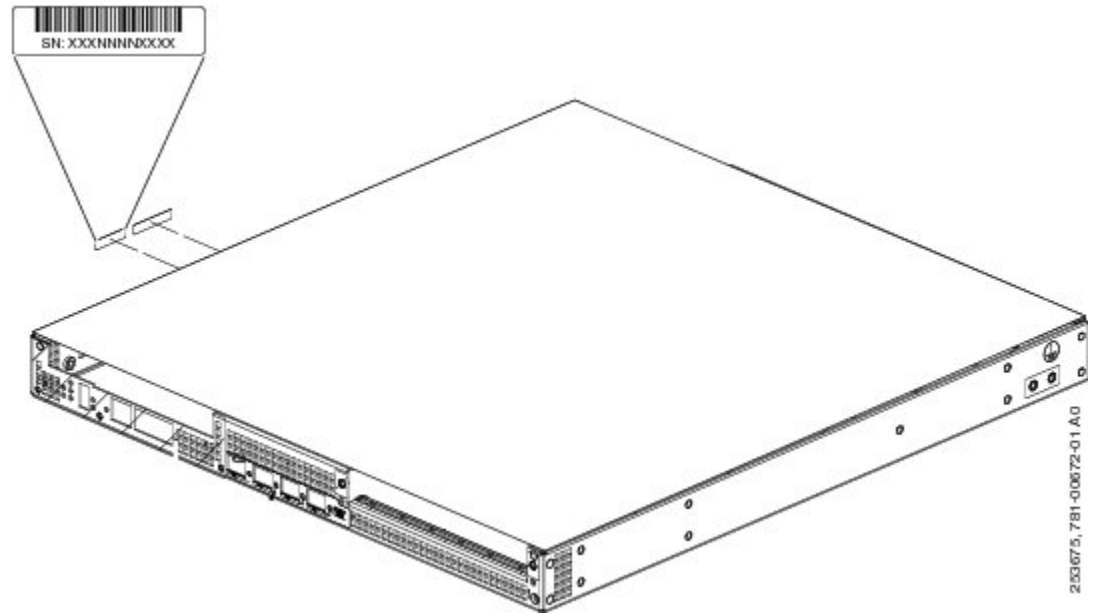

The following figure shows the serial number label location for the Cisco ASR 1002-X Router.

Figure 6: Cisco ASR 1002-X Router Serial Number Label Location

