



LiFePO₄ Battery Module for Telecom

NPFC Series

OPERATION MANUAL

Version V 1.0

NARADA POWER SOURCE CO., LTD

Email: intl@narada.biz Website: en.naradapower.com

Notes	 Safety and Warning	03
One	 Product Introduction	04
	Overview	04
	Working Principle	04
	Battery Management System (BMS)	05
	Applications	06
	Battery Model Instruction	06
	Electric Performance	07
	Structure and Mechanical Performance	07
Two	 Technical Characteristic	10
	Discharge Performance	10
	Charge Performance	11
	Constant Current/Power Discharge Datasheet	11
Three	 Operation and Maintenance	13
	Requirements for Operation Environment	13
	Parameter Settings of Power Plant	13
	Layout of Front Panel	14
	Installation	16
	Maintenance	19
Four	 Troubleshooting and Solutions	20
	Annex 1 – Instructions for LED Flicker	21
	Annex 2 – Instructions for Dialing of ADD	22
	Annex 3 – Communication Protocol for RS232 and RS485	23
	Annex 4 – LCD Menu Instruction	24

Safety and Warning

Chapter Notes

The NPFC series LiFePO₄ battery system installation, operation, maintenance should follow important recommendations in this manual:

- ⓘ The equipment shall be installed by the professional trained staff.
- ⓘ Battery maintenance should be carried out by the experienced professionals and aware of the preventive measures on the potential harm of the battery.
- ⓘ Note: Be careful of the risk of electric shock for large current in case of battery short circuit, pay attention to the following points during operation
 - Remove watches, rings or other metal objects
 - Use tools with insulated handles
 - Do not place tools or metal objects on the battery
- ⓘ Do not direct access to the battery system to the mains grid power outlet.
- ⓘ Do not put the battery system into fire, do not use or storage the battery near to the high temperature source.
- ⓘ Do not use liquid or other objects placed into the battery system.
- ⓘ Do not open or cut the battery, not hit, throw or step on the battery.
- ⓘ Using special communication between battery module and power plant to charge battery
- ⓘ Be sure to subject to charge and discharge parameters setting in this manual.
- ⓘ The output interface of the system is still voltage when grid power cut, avoid electric shock or short circuit when operation.
- ⓘ Please check if the box is damaged. If damaged, please immediately notify the supplier
- ⓘ If you find leaking liquid or white powder residue on product, prohibit operation.

Product Introduction

Chapter One/01

Overview

NPFC series battery system is 48V system for communications back-up type LiFePO₄ (lithium iron phosphate) battery products, the system uses the advanced LiFePO₄ battery technology with the benefit of long cycle life, small size, light weight, safety and environmental protection, and has a strong environmental adaptability, it is idea for harsh outdoor environments.

The system also integrates a smart battery management and monitoring module, support for remote centralized monitoring (optional) and remote battery management and maintenance (optional), to meet the requirements of unattended maintenance. Therefore, the NPFC system can fully meet the backup power supply requirements of the access network equipment, mobile communications equipment, transmission equipment, micro base stations and microwave communication equipment.

Working Principle

The NPFC battery system mainly includes Fe lithium battery pack, battery protection, cell balancing unit, monitoring module and charge-discharge management module for optional. Its schematic diagram shown in Figure 1.1

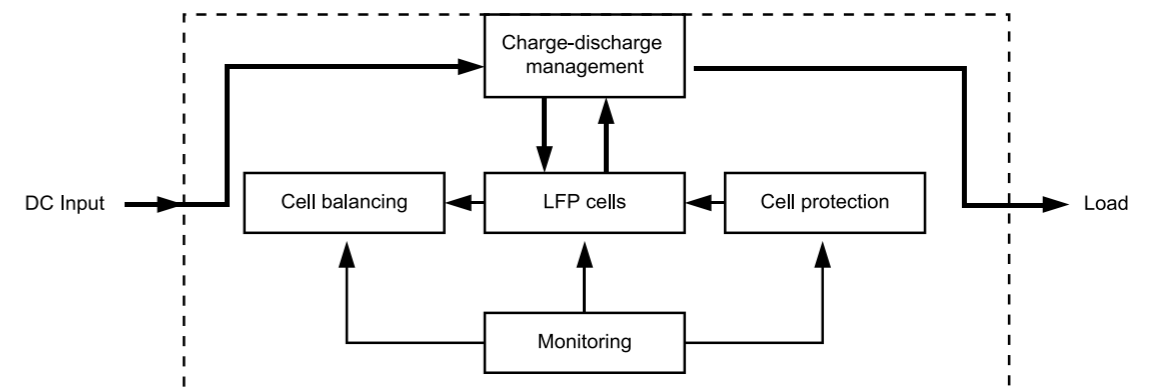

Fig. 1-1 Schematic Diagram

LFP cells	Chemical power, energy storage and power supply components.
Battery protection	Protect LFP cells against overcharge, over discharge, over current, over temperature, short circuit
Cell balancing	Equalization LFP cells for unbalanced cells
Charge-discharge management	Discharge circuit management, and charging current limit (optional according to customer requirements)
Monitoring	Support centralized monitoring system (optional according to customer requirements)

NPFC battery working principle:

DC power input charge and discharge management unit after filter, DC divided two circuits, one circuit directly supply the load, another circuit to charge Fe lithium pack. When grid power on, the system supply the loads and charging inside Fe lithium batteries; When grid power failure, Fe lithium inside system supply DC power to the load, to ensure uninterrupted power supply as power system.

Battery Management System (BMS)

Smart BMS technology is adopted for battery modules of NPFC series to assure smart automatic management for batteries. Features of BMS are shown as below:

- 1 There is a centralized monitoring unit in BMS. Functions such as remote measurement, remote communication, remote controlling are available. Battery modules can be controlled remotely by staffs in control center. NPFC series are in line with the requirements of the development of modern communications technology.
- 2 It is combined by technologies of power source and computer. Parameters and status of rectifiers and AC/DC distributions can be detected and controlled.
- 3 Excellent electromagnetic compatibility. BMS used for battery modules of NPFC series can comply with the outdoor power plants during operation, no interfere with each other.
- 4 BMS can provide protections against overcharge, over-discharge, over-temperature, overcurrent, short circuit, etc., to assure reliable safety and operation life.
- 5 With patented cell balancing technology, BMS provide high efficiency for cell balancing and prolong system operate life.
- 6 Configuration flexibility, support parallel connection expansion
- 7 For the Battery system, BMS threshold for total current acceptance is 200A

Applications

- 1 Network Telecommunication Facilities
- 2 OSP
- 3 Terminal of FTTX
- 4 Access network system
- 5 Indoor distribution system
- 6 Telecom BTS
- 7 Integrated outdoor power cabinet
- 8 UPS
- 9 Internet data center (IDC)
- 10 Solar energy
- 11 Common Bonding Network (CBN) and or Isolated Bonding Network (IBN)

Battery Model Instruction

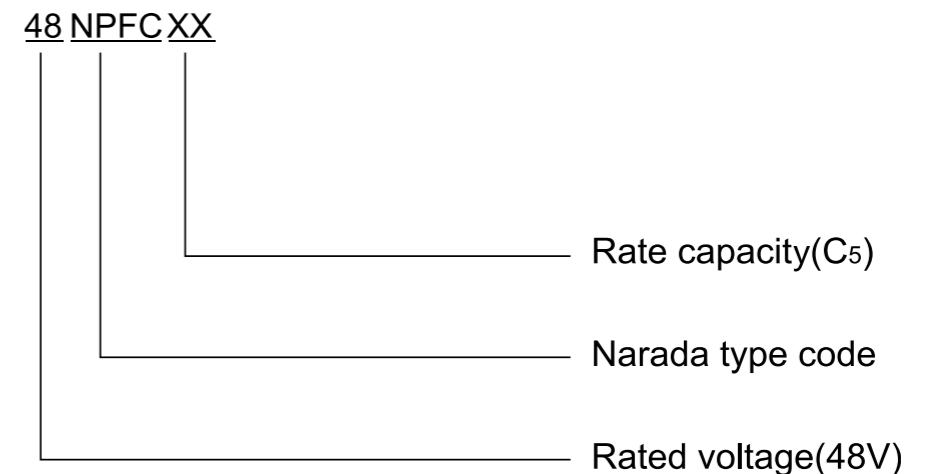

Fig. 1-2 Instruction of Battery Model for NPFC Series

Electric Performance

Table 1-1 Battery Model & Electric Performance of NPFC Series

Battery Model ^①	Rated Voltage ^② (V)	Rated Capacity ^③ (Ah)	Voltage Range (V)	Charge Voltage (V)	Charge Current (A)		Max. Discharge Current (A)
					Recomm	Max	
48NPFC10	48	10	40.5 to 54.5	54.0	2	10	10
48NPFC20	48	20	40.5 to 54.5	54.0	4	20	20
48NPFC50	48	50	40.5 to 54.5	54.0	10	50	50
48NPFC80	48	80	40.5 to 54.5	54.0	15	80	80
48NPFC100-19"	48	100	40.5 to 54.5	54.0	20	100	100
48NPFC100-23"	48	100	40.5 to 54.5	54.0	20	100	100

Notes: ^①Battery Model Battery models listed in the datasheet are standard products. Narada can also supply customized design in cell, BMS and dimensions for various application scenarios.

^②Rated Voltage 48V = 3.20Vpc * 15pcs (Rated voltage of each LFP cell is 3.20Vpc)

^③Rated Capacity Five hour rate capacity (0.2C to 40.5V at 25°C)

Structure and Mechanical Performance

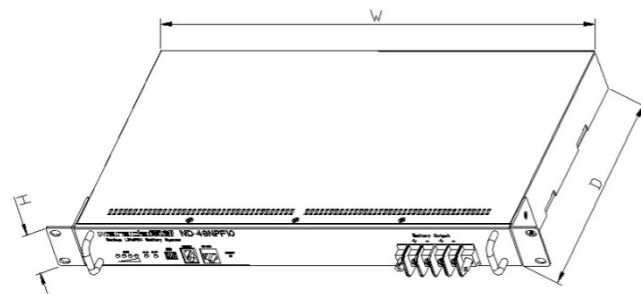

Fig. 1-3 Structural Drawing of NPFC Series Batteries (48NPFC10 as sample)

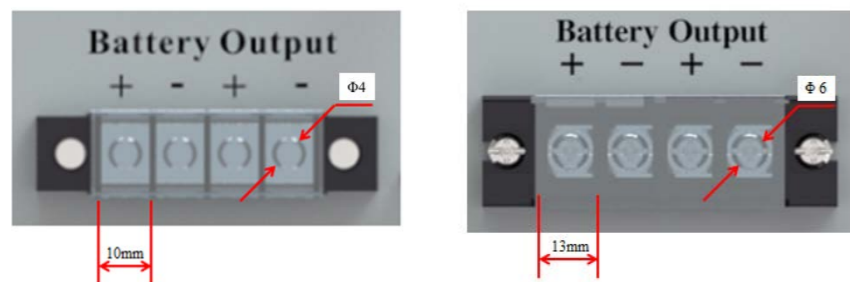

Fig. 1-4 Battery Output Terminal

Table 1-2 Mechanical Performance of NPFC Series

Battery Model ^①	Rated Voltage (V)	Rated Capacity (Ah)	Dimensions(mm)			Weight (Kg)	Battery Output Terminal	
			Width	Depth	Height			
48NPFC10	48	10	442	245	44	1U	7.3	10mm/M4
48NPFC20	48	20	442	245	88	2U	13.4	10mm/M4
48NPFC50	48	50	442	390	132.5	3U	29.5	13mm/M6
48NPFC80	48	80	442	400	132.5	3U	39.0	13mm/M6
48NPFC100-19"	48	100	442	400	220	5U	51.5	13mm/M6
48NPFC100-23"	48	100	520	420	132.5	3U	49.0	13mm/M6

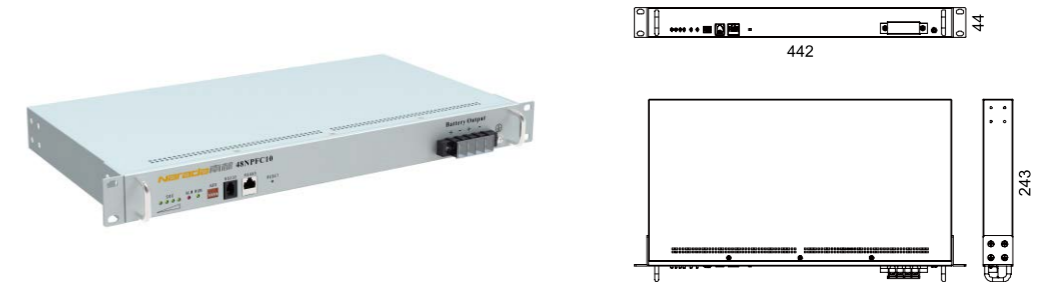

Fig. 1-5 Appearance & Mechanical Drawing of 48NPFC10

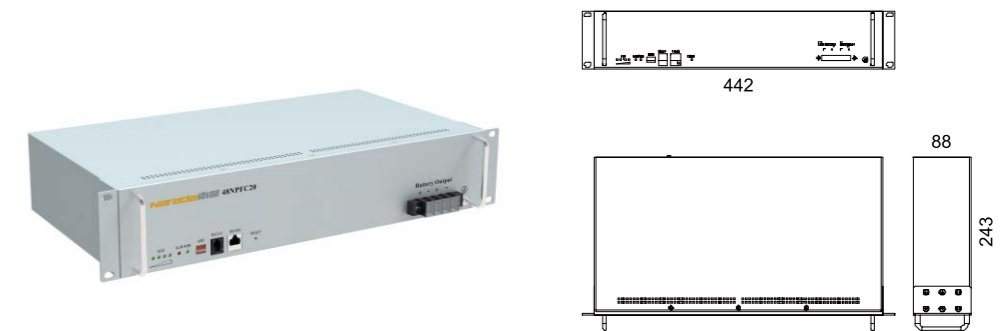

Fig. 1-6 Appearance & Mechanical Drawing of 48NPFC20

Technical Characteristic

Chapter Two/02

Discharge Performance

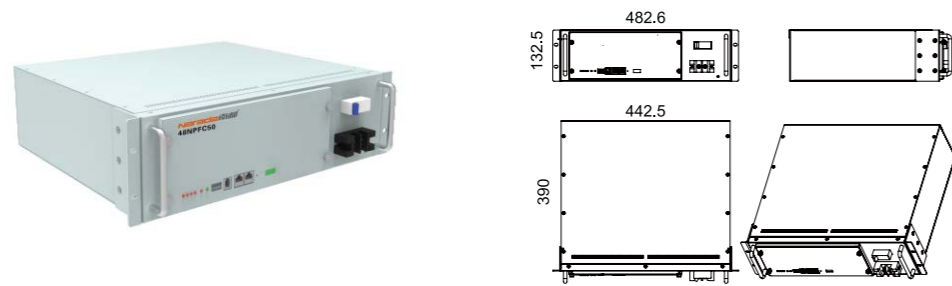

Fig. 1-7 Appearance & Mechanical Drawing of 48NPFC50

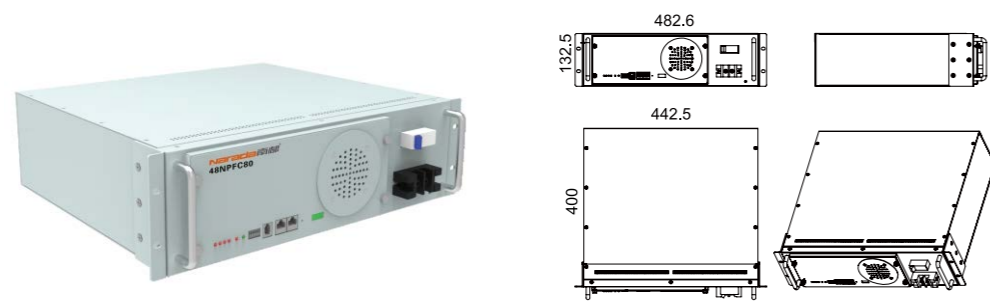

Fig. 1-8 Appearance & Mechanical Drawing of 48NPFC80

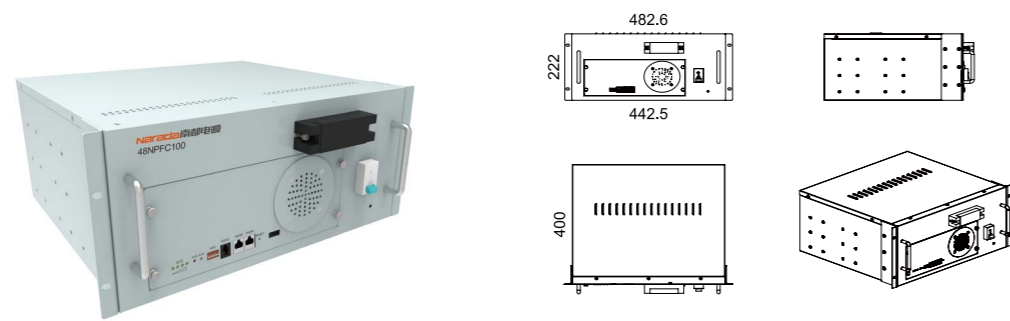

Fig. 1-9 Appearance & Mechanical Drawing of 48NPFC100(19'')

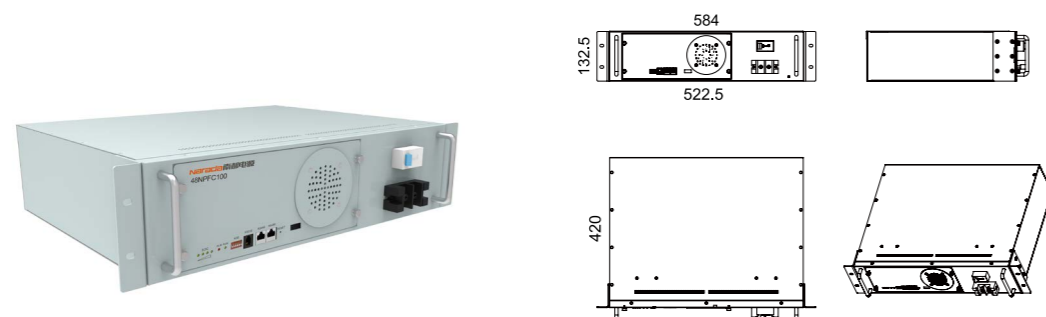

Fig. 1-10 Appearance & Mechanical Drawing of 48NPFC100(23'')

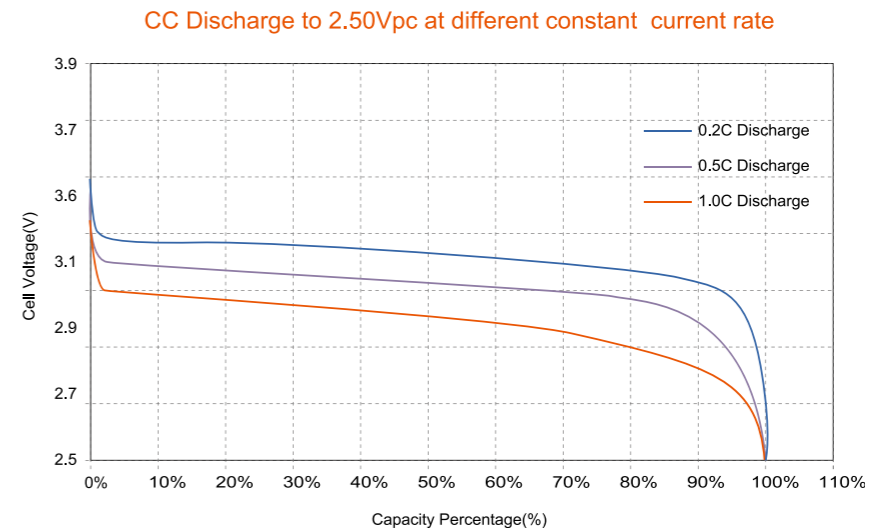

Fig. 2-1 Constant Current Discharge Curve of NPFC Series

Charge Performance

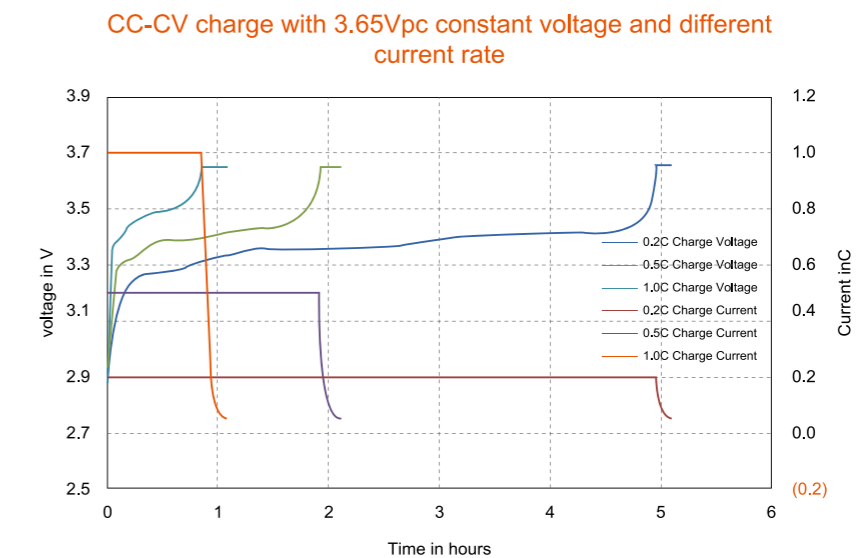

Fig. 2-2 Charge Characteristic with Various Current Limitation of NPFC Series

Constant Current/Power Discharge Datasheet

Table 2-1 Constant Power Discharge @77F/25C

End Voltage	10h	8h	5h	3.5h	2.5h	2h	1.5h	1h	30min
48NPFC10 Constant power discharge									
46.5V	49.0	60.0	96.0	135	131	220	283	387	529
45.0V	49.9	61.4	98.2	138	136	233	307	445	647
43.5V	50.5	62.1	99.4	140	138	238	312	459	675
42.0V	50.9	62.5	100	141	139	240	317	467	687
40.5V	51.1	62.9	101	142	140	242	320	470	689
39.0V	51.2	63.0	101	142	141	243	321	475	701
End Voltage	10h	8h	5h	3.5h	2.5h	2h	1.5h	1h	30min
48NPFC20 Constant power discharge									
46.5V	98.0	120.0	192	270	262	440	566	774	1058
45.0V	99.8	122.7	196	277	273	467	614	891	1294
43.5V	101	124	199	280	276	477	624	918	1349
42.0V	102	125	200	282	279	480	635	934	1373
40.5V	102	126	201	284	280	484	640	939	1377
39.0V	102	126	202	285	282	485	643	950	1403
End Voltage	10h	8h	5h	3.5h	2.5h	2h	1.5h	1h	
48NPFC50 Constant power discharge									
46.5V	245.1	300.1	480.2	675	655	1100	1414	1934	
45.0V	249.6	306.8	490.8	692	682	1167	1534	2227	
43.5V	252.4	310.5	496.8	700	690	1192	1561	2294	
42.0V	254.3	312.6	500	706	697	1200	1587	2334	
40.5V	255.4	314.3	503	709	701	1209	1601	2348	
39.0V	256.1	315.1	504	712	705	1213	1607	2374	
End Voltage	10h	8h	5h	3.5h	2.5h	2h	1.5h	1h	
48NPFC80 Constant power discharge									
46.5V	392.1	480.2	768.3	1079.2	1048.8	1760.6	2262.1	3094.4	
45.0V	399.3	490.8	785.3	1106.7	1091.4	1867.3	2454.2	3563.9	
43.5V	403.9	496.8	795.0	1120.4	1103.6	1907.4	2496.9	3670.7	
42.0V	406.8	500.2	800.3	1129.5	1115.8	1920.7	2539.6	3734.7	
40.5V	408.7	502.8	804.6	1134.1	1121.9	1934.0	2560.9	3756.0	
End Voltage	10h	8h	5h	3.5h	2.5h	2h	1.5h	1h	
48NPFC100 Constant power discharge									
46.5V	490.1	600.3	960.4	1349.0	1311.0	2200.8	2827.6	3868.0	
45.0V	499.1	613.5	981.6	1383.4	1364.3	2334.1	3067.8	4454.9	
43.5V	504.9	621.0	993.8	1400.5	1379.5	2384.3	3121.1	4588.4	
42.0V	508.5	625.3	1000.4	1411.9	1394.8	2400.9	3174.5	4668.4	
40.5V	510.9	628.5	1005.8	1417.6	1402.4	2417.5	3201.1	4695.0	
39.0V	512.1	630.3	1008.4	1423.4	1410.0	2425.9	3214.5	4748.4	

Table 2-2 Constant Current Discharge @25C/77F

End Voltage	10h	8h	5h	4h	2.5h	2h	1.5h	1h	30min
48NPFC10 Constant current discharge									
46.5V	1.0	1.2	1.9	2.4	3.5	4.2	5.2	6.9	13.3
45.0V	1.0	1.2	2.0	2.4	3.8	4.7	6.6	8.8	16.9
44.1V	1.0	1.2	2.0	2.5	3.9	4.8	6.8	9.0	17.4
43.5V	1.0	1.2	2.0	2.5	3.9	4.9	7.0	9.3	17.9
42.0V	1.0	1.3	2.0	2.5	4.0	4.9	7.1	9.5	18.3
40.5V	1.0	1.4	2.0	2.5	4.0	5.0	7.2	9.7	18.6
39.0V	1.0	1.3	2.0	2.5	4.0	5.0	7.3	9.7	18.8
End Voltage	10h	8h	5h	4h	2.5h	2h	1.5h	1h	30min
48NPFC20 Constant current discharge									
46.5V	1.9	2.4	3.8	4.8	7.1	8.4	10.3	13.8	24.9
45.0V	2.0	2.4	3.9	4.9	7.7	9.4	13.2	17.6	33.2
44.1V	2.0	2.5	3.9	4.9	7.8	9.6	13.5	18.1	34.2
43.5V	2.0	2.5	4.0	5.0	7.8	9.7	13.9	18.6	35.1
42.0V	2.0	2.5	4.0	5.0	7.9	9.9	14.3	19.0	36.7
40.5V	2.0	2.5	4.0	5.0	8.0	10.0	14.5	19.3	37.2
39.0V	2.0	2.5	4.0	5.0	8.0	10.0	14.6	19.4	37.5
End Voltage	10h	8h	5h	3.5h	2.5h	2h	1.5h	1h	
48NPFC50 Constant Current discharge									
46.5V	4.8	6.0	9.5	11.9	17.8	21.0	27.7	34.4	
45.0V	4.9	6.1	9.7	12.1	19.1	23.5	33.7	43.9	
44.1V	4.9	6.1	9.8	12.3	19.4	23.9	34.6	45.2	
43.5V	5.0	6.2	9.9	12.4	19.6	24.3	35.4	46.4	
42.0V	5.0	6.2	9.9	12.4	19.8	24.6	36.1	47.5	
40.5V	5.0	6.3	10.0	12.5	20.0	24.9	36.6	48.2	
39.0V	5.0	6.3	10.0	12.6	20.0	25.0	36.8	48.6	
End Voltage	10h	8h	5h	3.5h	2.5h	2h	1.5h	1h	
48NPFC80 Constant Current discharge									
46.5V	7.6	9.5	15.2	19.0	28.2	33.5	44.3	55.1	
45.0V	7.6	9.8	15.5	19.4	30.6	37.6	53.9	70.2	
44.1V	7.7	9.8	15.7	19.7	31.0	38.3	55.3	72.2	
43.5V	7.9	9.9	15.8	19.9	31.3	38.9	56.6	74.3	
42.0V	7.9	10.0	15.9	19.9	31.7	39.4	57.7	76.0	
40.5V	8.0	10.0	16.0	20.0	32.0	39.8	58.5	77.1	
End Voltage	10h	8h	5h	3.5h	2.5h	2h	1.5h	1h	
48NPFC100 Constant power discharge									
46.5V	9.5	11.9	19.0	23.8	35.3	41.9	55.4	68.9	
45.0V	9.5	12.3	19.4	24.3	38.3	47.0	67.4	87.8	
44.1V	9.6	12.3	19.6	24.6	38.8	47.9	69.1	90.3	
43.5V	9.9	12.4	19.8	24.9	39.1	48.6	70.8	92.9	
42.0V	9.9	12.5	19.9	24.9	39.6	49.3	72.1	95.0	
40.5V	10.0	12.5	20.0	25.0	40.0	49.8	73.1	96.4	
39.0V	10.0	12.6	20.1	25.1	40.0	50.1	73.6	97.1	

Operation and Maintenance

Chapter Three/03

Requirements for Operation Environment

Table 3-1 Requirements for Operation Environment

Temperature Range (°C)			Recommended Temperature (°C)			Humidity
Discharge	Charge	Storage	Discharge	Charge	Storage	
-20 ~ +60	0 ~ +60	0 ~ +40	+15 ~ +35	+15 ~ +35	+15 ~ +30	5% ~ 95%

Parameter Settings of Power Plant

Lead-acid batteries can be replaced by lithium battery of NPFC series if power is matched. Table 3-2 is new parameter settings of power plant for lithium battery.

Table 3-2 Parameter Settings of Power Plant for NPFC Series Batteries

No.	Parameters	Units	Defaults
1	Float charge voltage	V	54.0
2	Equalization charge voltage	V	NA or 54.1
3	Standard charge current	A	0.2C
4	Charge current limitation	A	0.5C ~ 1.0C
5	Equalization charge interval	day	NA
6	Equalization charge duration	H	NA
7	Condition to equalization charge	A	NA
8	Condition to float charge	A	0.05C
9	LVLD (Low voltage load disconnection)	V	> 43.2
10	LVBD (Low voltage battery disconnection)	V	> 40.5
11	Restore voltage for LVBD	V	/
12	Temperature compensation for float charge	-mV/°C	NA
13	Temperature compensation for equalization charge	-mV/°C	NA

Note: 1. Equalization charge is requested to switch off for NPFC series batteries.
 2. Rectifier parameter shall be set according to specific site requirement based on battery units used.
 3. System discharge and charge current allowance of less than 200A for BMS

Layout of Front Panel

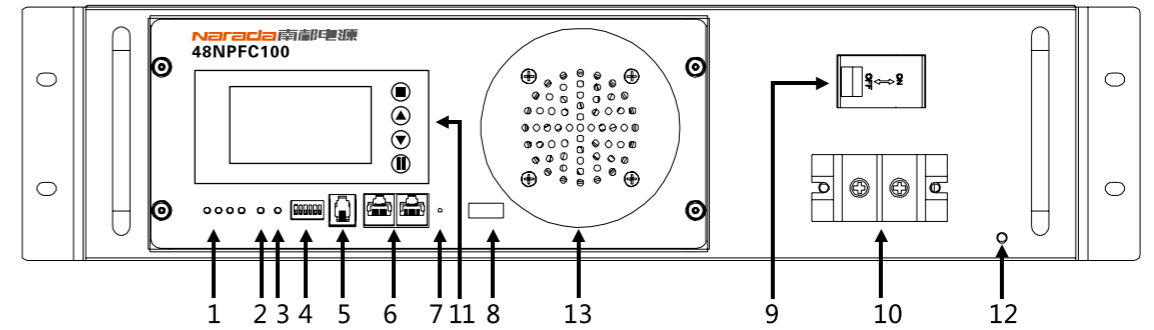

Fig. 3-1 Layout of Front Panel for NPFC Series Batteries

Table 3-3 Instruction for Layout of Front Panel

No.	Marks	Functions	Detailed Information
1	SOC	Indicators for capacity	There are four green LED lights in front panel indicating SOC. SOC is short for state of charge. Each SOC LED light represents 25% of rated capacity. Detailed information is shown in Annexed Table 1.1.
2	ALM	Indicator for alarms	There is one red LED light in front panel indicating alarms. Detailed information is shown in Annexed Table 1.2.
3	RUN	Indicator for running status	There is one green LED light in front panel indicating running status. Detailed information is shown in Annexed Table 1.3.
4	ADD	Address of communication	ADD is applicable to modules connected in parallel. ADD consists of four binary bits, and maximum quantity of batteries connected in parallel is 16pcs (2 ⁴). Detailed information is shown in Annex 2.
5	RS232	Up-link communication port	It is adopting RS-232 series port to upload data. Contents of data transmit include BMS parameters, battery running status, alarms, etc. Generally, speed rate of RS-232 is 1200bps. RS232 up-link communication can be available for the battery module with a binary communication address of 0000 (Master PACK). Protocol for RS232 communication is shown in Annexed Table 3.1

6	RS485	Cascading communication port	It is adopting RS485 series port communication pattern to upload data. Communication of modules connected in parallel (Slave PACKs) is available through RS 485. Data of slave PACKs will be transmitted to Master PACK. Protocol for RS232 communication is shown in Annexed Table 3.2
7	RESET	Reset button	Press RESET button when abnormality occurs to assure stability of battery performance.
8	Dry contact	Dry contact indicators	Indicate BMS or battery fail including but not limited to charge and discharge MOS fail, cell voltage under 0.5V, NTC disconnect.
9	Power switch	ON/OFF switch	When turn-off, battery get into sleep mode, and cut-off output, the alarm output also will be stopped.
10	Battery Output	Terminals for battery output	Using terminals with four cores. Polarities are +, -, +, - from left to right. The two '+' and '-' are equal relatively. Detailed information is shown in Fig. 2.4.
11	LCD (optional)	Display battery information	Detailed information is shown in Annexed Table 3.3
12	GND	Ground screw	Connect earth by flexible cable above GREEN Sheathed, UL94-V0, gauge of the grounding wire should be equal to or greater than the gauge of the battery return wire, .no less than 6AWG, connection through 2-hole 0.75in center spacing, on right side of cabinet back.
13	Vented holes	Cooling FAN	Cooling system to disperse BMS heat

Installation

Unboxing & Inspection

- Please study this manual before installation.
- Please inspect the package before unboxing, if any destroy with appearance, contact with the supplier as soon as possible.
- This device shall be installed and operated by professionals.

Preparation for Installation

- Batteries shall not be placed in direct sunshine or close to heat source.
- Batteries shall be installed in place with good ventilation to assure enough heat dissipation.
- Batteries shall be placed in are with clean ambient and low humidity.
- Heavy weight shall not be placed on any cable.
- Following are the tools possibly but not limited be use for installation:

Items	Tool Items	Remarks for Use
1	Insulation gloves	Insulation protection for body
2	Insulation taps	Insulation protection for tools
3	Screw drivers	Fix the cables of the batteries & power plant
4	Multi meter	Measure the module voltage in commission
5	Current meter	Measure the module current in commission
6	USB to RS485 cable	For communication between the batteries and laptop
7	Laptop	Operate the software

Installation of Battery Modules

1. Installation and fixation

Battery modules of NPFC series are applicable to installation in 19 inch cabinets and wall-hanging.

- 19 inch cabinet installation
Insert battery module into 19 inch cabinet, and fix two handles of battery module with cabinet rack using 4pcs M6 screws.
- Wall-hanging installation
Wall-hanging installation also can be adopted, fix two handles of battery module with triangle rack on the wall using 4pcs M6 screws.

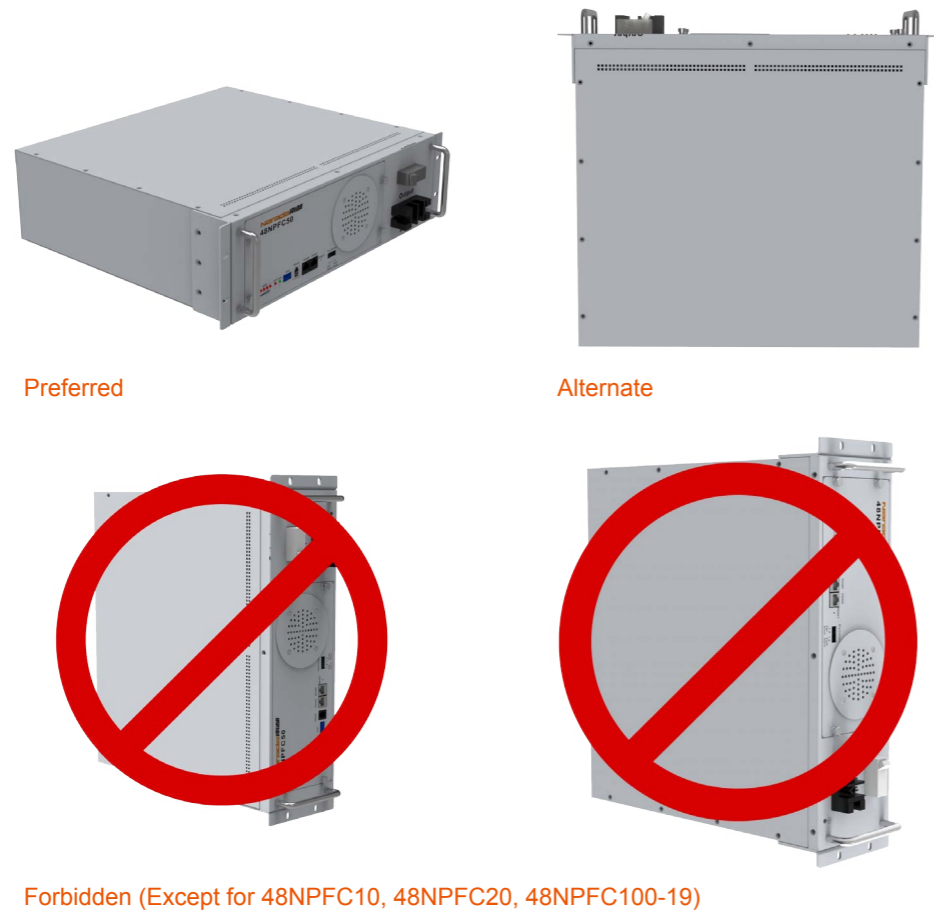

- Color for cable between '+' and positive bar is suggested as RED, and cable between '-' and negative or breaker as BLACK



Fig. 3-3 Layout of paralleling connection for NPFC Series Batteries

2. Ground connection

GND screw on the 2-holes side panel of battery is connected with ground through a flexible cable equal to or greater than the gauge of the battery return wire, no less than 6AWG. In instances where the battery module is deployed in a central office environment, please assure that a method has been implemented at the battery module's demarcation point, or within the adjacent power distribution network, that assures the supply return is referenced to ground.

3. Battery output connection

- Connect '+' of battery output with positive female copper bar of power plant, and '-' with negative female copper bar or breaker (optional).
- If multi battery modules will be connected in parallel, connect '+' of battery output of each battery module with positive female copper bar of power plant, and '-' with negative female copper bar of power plant or breaker (optional) separately, see Fig4.3.
- Length of cable between battery module and power plant shall be less than 2.0m. To make sure similar voltage drop of cable for each battery, length of all positive and negative cables should be the same.

4. Power on for battery module

- When installation is accomplished, battery module is in dormant state. Once power on for the power plant and battery module, battery will go into normal running status, and discharge/charge can be available.
- Parameter settings for lithium battery modules in power plant are shown in Table 4.2.

5. RS232/RS485 connection

- If there is only one battery module in operation, communication between battery module and computer can available through both RS232 and RS485.
- If there are more than one battery modules in operation, parallel communication can be available using RS485.
- Communication protocols for RS232 and RS485 are shown in Annex 3.

6. Discharge with dummy load

- Dummy load cannot be larger maximum discharge current of each battery model in Table 2.1, and LVBD is larger than 40.5V.
- Voltage drop on cable between battery module and power plant shall be less than 0.5V.
Method of calculation for cross sectional area of cable is shown as below.

$$A = \Sigma I \times L / (K \times \Delta U)$$

In the above formula, A is across sectional area of wire (mm²), ΣI is the total current (A), L is length of cable, ΔU is the permit voltage drop on cable (V), and K is electrical conductivity of wire. For example, for copper, K = 57.

Maintenance

- ⬇ The battery shall be recharged every three months if in long time storage
- ⬇ Please clean the dust by the dust collector when dust is accumulated on vent
- ⬇ Please use clean and dry cloth/fabric to clean up the cabinet, if need further cleaning, please use neutral cleanser. Alcohol or ammonia synthesis is forbidden.
- ⬇ Carrying shall be handled gently, prevent from severe compact
- ⬇ Prevent battery from splashing liquid
- ⬇ Suggest inspect the tighten of output screw every two years

Troubleshooting and Solutions

Chapter Four/04

Table 4-1 Troubleshooting and Solutions

Troubles	Troubleshooting	Solutions
Battery cannot discharge	Protection against under-voltage	Charge battery
	Protection against over-temperature or under-temperature (cell temperature is lower than -25°C or higher than 75°C)	Regulate cell temperature in the range of -20°C to 60°C for discharge
	Battery output is short circuit	Relieve short circuit and charge battery
	Protection against over current	Remove some unimportant load and charge battery
Battery cannot charge	System failure	Shutdown system and call maintenance service
	Battery is fully charged. Normal charge management	Do not need to solve
	Protection against over voltage	Do not need to solve
	Protection against over-temperature or under-temperature (cell temperature is lower than -10°C or higher than 65°C)	Regulate cell temperature in the range of 0°C to 55°C for charge
All LED indicators on	System failure	Shutdown system Call for maintenance service
	System failure	Shutdown system and call maintenance service
Communication failure	Fault of communication cable	Inspect communication cable
	Halt of SCM	Press RESET button
	System failure	Shutdown system Call for maintenance service

Different flash status of LED indicators represents corresponding running status or alarms. Detailed information is shown Annex 1.

Annex 1-Instructions for LED Flash

Annex Table 1.1 – SOC LED Indicators Description

●	●	●	●	SOC
☀	☀	☀	☀	75% ~ 100%
☀	☀	☀	○	50% ~ 75%
☀	☀	○	○	25% ~ 50%
☀	○	○	○	0% ~ 25%

Note: ☀ mean light on, ○ mean light off

Annex Table 1.2 – RUN Indicators Description

Flash Status	Running Status of Battery
Flash 1	Activation state, but neither charge nor discharge
Flash 2	Charging state
Continue light	Discharging state
Extinguish	Dormant state

Annex Table 1.3 – ALM Indicators Description

Flash Status	Alarm Information of Battery
Extinguish	Minor Alarm(Various Alarm Status)
Flash 2	Fail(Various fail)
Flash 3	Major Alarm(Various protection status)
Extinguish	Normal, no alarm

Annex Table 1.4 – Flash Instruction of LED Indicators

	ON	OFF
Flash 1	0.25s	3.75s
Flash 2	0.5s	0.5s
Flash 3	0.5s	1.5s

Annex 2-Instructions for Dialing of ADD

ADD is applicable to modules connected in parallel. ADD consists of four binary bits, and maximum quantity of batteries connected in parallel is 16pcs (2⁴).

Annex Table 2.1 – Instruction for Addresses of Communication

Instructions for ADD Dialing				Module No.	Binary Code	Remarks
1	2	3	4			
OFF	OFF	OFF	OFF	PACK 1	0000	Master PACK, supports RS232
ON	OFF	OFF	OFF	PACK 2	0001	Slave PACK
OFF	ON	OFF	OFF	PACK 3	0010	Slave PACK
ON	ON	OFF	OFF	PACK 4	0011	Slave PACK
OFF	ON	OFF	OFF	PACK 5	0100	Slave PACK
ON	OFF	ON	OFF	PACK 6	0101	Slave PACK
OFF	ON	ON	OFF	PACK 7	0110	Slave PACK
ON	ON	ON	OFF	PACK 8	0111	Slave PACK
OFF	OFF	OFF	ON	PACK 9	1000	Slave PACK
ON	OFF	OFF	ON	PACK 10	1001	Slave PACK
OFF	ON	OFF	ON	PACK 11	1010	Slave PACK
ON	ON	OFF	ON	PACK 12	1011	Slave PACK
OFF	OFF	ON	ON	PACK 13	1100	Slave PACK
ON	OFF	ON	ON	PACK 14	1101	Slave PACK
OFF	ON	ON	ON	PACK 15	1110	Slave PACK
ON	ON	ON	ON	PACK 16	1111	Slave PACK

Annex Table 2.3 – Instruction of ADD for Parallel Communication

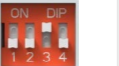
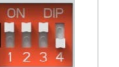
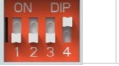
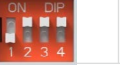
PACK 1 0000 ADD 	PACK 2 0001 ADD 	PACK 3 0010 ADD 	PACK 4 0011 ADD 	PACK 5 0100 ADD 	PACK 6 0101 ADD 	PACK 7 0110 ADD 	PACK 8 0111 ADD 
PACK 9 1000 ADD 	PACK 10 1001 ADD 	PACK 11 1010 ADD 	PACK 12 1011 ADD 	PACK 13 1100 ADD 	PACK 14 1101 ADD 	PACK 15 1110 ADD 	PACK 16 1111 ADD 

Note: Counting of ADD shall begin from 0000, without interruption, or parallel communication cannot be available

Annex 3 – Communication Protocol for RS232 and RS485

There is one RS232 port in front panel for up-link communication between batter module and upper computer, and one RS485 port in front panel for cascade communication for battery modules connected in parallel.

Annex Table 3.1 – RJ11 Pins Assignment (RS232)

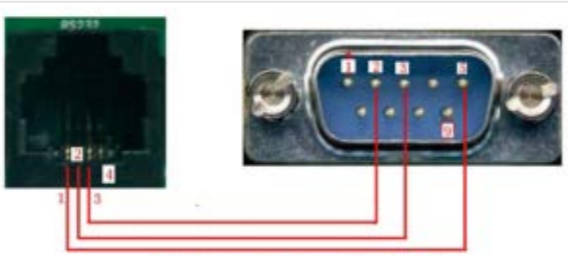
RJ11 Pins	Definition	Sketch
1	GND	 <p>2 RXD Receive data - From battery to computer 3 TXD Deliver data - From computer to battery 5 GND – Signal ground</p>
2	Pack receipt, computer delivery	
3	Pack delivery, computer receipt	
4	No connection	

Annex Table 3.2 – RJ45 Pins Assignment (RS485)

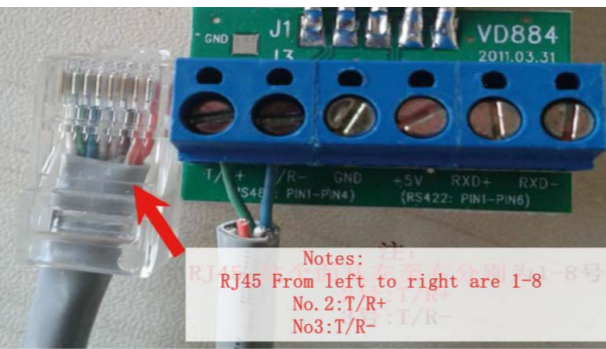
RJ45 Pins	Definition	Sketch
1	GND	 <p>Notes: RJ45 From left to right are 1-8 No. 2:T/R+ No3:T/R-</p>
2	RS485_A	
3	RS485_B	
4,5,6,7,8	No connection	

Annex 4 – LCD Menu Instruction(optional)

Press “MENU” to enter the following interface
Welcome
Battery manage system

Press “MENU” next
Press “MENU” to enter the following interface
Battery parameters query
Battery status
Battery parameter settings
Version Information

The “Battery Parameters” subdirectory

- Voltage: xxxx V
- Current: xxxx A (charge:+, discharge:-)

The “Battery Temperature” Subdirectory

- Temperature01:xx°C
- Temperature02:xx°C
- Temperature03:xx°C
- Temperature04:xx°C
- PCB Temperature: xx°C
- Environment Temperature: xx°C
- The “Cell Voltages” Subdirectory
- Cell01: xxxx mV
- Cell02: xxxx mV
- Cell03: xxxx mV
- Cell04: xxxx mV
- Cell05: xxxx mV
- Cell06: xxxx mV
- Cell07: xxxx mV
- Cell08: xxxx mV
- Cell09: xxxx mV
- Cell10: xxxx mV

- Cell11: xxxx mV
- Cell12: xxxx mV
- Cell13: xxxx mV
- Cell14: xxxx mV
- Cell15: xxxx mV
- Cell16: xxxx mV
- SOC: xxxx%
- Nominal Capacity: xxxx Ah

The “Battery Status” Subdirectory

- Status: IDLE/CHARGE/DISCHARGE
- “Alarm status” Subdirectory
 - Overvoltage alarm YES/NO
 - Under voltage alarm YES/NO
 - Over temperature YES/NO
 - Under voltage alarm YES/NO
 - Under capacity alarm YES/NO
 - Difference voltage YES/NO
 - Overcurrent YES/NO
 - Charger Reverse alarm YES/NO
- “Protection status” Subdirectory
 - Overvoltage protect YES/NO
 - Under voltage protect YES/NO
 - Over temperature protect YES/NO
 - Under temperature protect YES/NO
 - Over current protect YES/NO
 - Short current protect YES/NO
- “Fail alarm” Subdirectory
 - Sampling line: OK/ERROR
 - Charge MOSFET: OK/ERROR
 - Discharge MOSFET: OK/ERROR
 - Sampling chip: OK/ERROR
 - Short current times: xxxx

- Temperature protect times: xxxx
- Over protect times: xxxx
- Over current times: xxxx
- Under voltage times: xxxx

The “Battery parameter settings” Subdirectory Non-manufacturers cannot enter
10 NPFC series LiFePO4 Battery System for Telecommunication Operation manual V1.0

The “Version Information” Subdirectory

- “BMS version” Subdirectory
 - BMS software version
 - BMS hardware version
- The “LCD version” Subdirectory
 - LCD software version:
 - LCD hardware version:

LCD Instructions BMS under sleep mode please press“MENU”wake the BMS and LCD With in one minute without operating LCD into turn off: Please press “MENU” wake the BMS and LCD

After-sale Services

NARADA POWER SOURCE CO., LTD.

Building A, No.822 Wen'er West Road, Hangzhou, Zhejiang, China

Tel: +86-571-56975980

Fax: +86-571-56975955

Website: en.naradapower.com E-mail: intl@narada.biz

NARADA ASIA PACIFIC PTE. LTD.

Block 9 Khaki Bukit Road 1 #02-10 Eunos Technolink, Singapore 415938

Tel: +65-6848 1191

Fax: +65-6749 3498

Website: www.narada-ap.com

Email: sales@narada-ap.com

NARADA EUROPE (UK) LIMITED

Spectrum House, Dunstable Road, Redbourn, St. Albans, Herts AL3 7PR

Tel: +44 (0)845 612 2031

Fax: +44 (0)845 612 2031

E-mail: sales@naradaeurope.com