

TEST REPORT IEC 62040-1 Uninterruptible power systems (UPS) – Part 1: General and safety requirements for UPS	
Report Number	ES170731048S
Date of issue	November 01, 2017
Total number of pages.....	86 pages
Name of Testing Laboratory preparing the Report.....	EMTEK (Shenzhen) Co., Ltd.
Applicant's name.....	INVT POWER SYSTEM(SHENZHEN) CO., LTD
Address	5th Floor, 1#Building, Gaofa Industrial Park, LongJing, Nanshan District, Shenzhen, China, 518055
Test specification:	
Standard	IEC 62040-1:2008 (First Edition) + Am 1: 2013
Test procedure	CE-LVD
Non-standard test method	N/A
Test Report Form No.....	IEC62040_1D
Test Report Form(s) Originator	TÜV Rheinland Japan Ltd.
Master TRF	Dated 2016-08
<p>Copyright © 2016 IEC System of Conformity Assessment Schemes for Electrotechnical Equipment and Components (IECEE System). All rights reserved.</p> <p>This publication may be reproduced in whole or in part for non-commercial purposes as long as the IECEE is acknowledged as copyright owner and source of the material. IECEE takes no responsibility for and will not assume liability for damages resulting from the reader's interpretation of the reproduced material due to its placement and context.</p> <p>If this Test Report Form is used by non-IECEE members, the IECEE/IEC logo and the reference to the CB Scheme procedure shall be removed.</p> <p>This report is not valid as a CB Test Report unless signed by an approved CB Testing Laboratory and appended to a CB Test Certificate issued by an NCB in accordance with IECEE 02.</p>	
General disclaimer:	
<p>The test results presented in this report relate only to the object tested.</p> <p>This report shall not be reproduced, except in full, without the written approval of the Issuing CB Testing Laboratory. The authenticity of this Test Report and its contents can be verified by contacting the NCB, responsible for this Test Report.</p>	
Test item description	Uninterruptible Power System(UPS)
Trade Mark	INVT
Manufacturer.....	Same as applicant
Model/Type reference	RM080/20C, RM100/25C, RM120/20C, RM150/25C RM160/20C, RM200/25C
Ratings	See rating label for details.

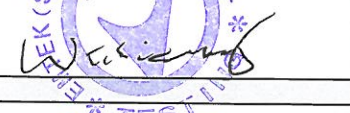

Responsible Testing Laboratory (as applicable), testing procedure and testing location(s):		
<input checked="" type="checkbox"/>	CB Testing Laboratory:	EMTEK (Shenzhen) Co., Ltd.
Testing location/ address.....:		Bldg 69, Majialong Industry Zone, Nanshan District, Shenzhen, Guangdong, China
<input type="checkbox"/>	Associated CB Testing Laboratory:	
Testing location/ address.....:		
Tested by (name, function, signature).....:		Gary Zhang / Engineer 
Approved by (name, function, signature)....:		William Guo / Manager 
<input type="checkbox"/>	Testing procedure: CTF Stage 1:	
Testing location/ address.....:		
Tested by (name, function, signature).....:		
Approved by (name, function, signature)....:		
<input type="checkbox"/>	Testing procedure: CTF Stage 2:	
Testing location/ address.....:		
Tested by (name + signature)		
Witnessed by (name, function, signature) .:		
Approved by (name, function, signature)....:		
<input type="checkbox"/>	Testing procedure: CTF Stage 3:	
<input type="checkbox"/>	Testing procedure: CTF Stage 4:	
Testing location/ address.....:		
Tested by (name, function, signature).....:		
Witnessed by (name, function, signature) .:		
Approved by (name, function, signature)....:		
Supervised by (name, function, signature) :		

<p>List of Attachments (including a total number of pages in each attachment):</p> <ul style="list-style-type: none"> - Attachment 1: National difference for IEC 62040-1:2008 (3 pages) - Photo document (20 pages) 	
<p>Summary of testing:</p>	
<p>Tests performed (name of test and test clause):</p> <ul style="list-style-type: none"> • Tests performed on the bench • Maximum ambient temperature: +40°C • Tested for moderate conditions. • EUT is designed for altitudes not exceeding 2000m. • Installation category II is specified in installation manual for this product. • Pre-production sample without serial number. • Test on model: RM200/25C can represent other models. For model differences refer to page 15. • The EUTs pass the tests. 	<p>Testing location:</p> <p>EMTEK (Shenzhen) Co., Ltd. Bldg 69, Majialong Industry Zone, Nanshan District, Shenzhen, Guangdong, China</p>
<p>Summary of compliance with National Differences (List of countries addressed):</p> <p>List of countries addressed: Group differences and national differences for CENELEC countries were checked.</p> <p><input checked="" type="checkbox"/> The product fulfils the requirements of EN 62040-1: 2008+A1: 2013.</p>	



Copy of marking plate:

The artwork below may be only a draft. The use of certification marks on a product must be authorized by the respective NCBs that own these marks.



1. Rating label for model RM080/20C:

	RM080/20
UPS	80kVA 3Ø+N
RETE 1 - MAINS 1 - NETZ 1	3Ø+N
Uin (Vac)	380/400/415
Iin (A)	156*
Frequenza - Frequency - Frequenz	50÷60Hz
RETE 2 - MAINS 2 - NETZ 2	3Ø+N
Uin (Vac)	380/400/415
Iin (A)	--
Frequenza - Frequency - Frequenz	50÷60Hz
USCITA - OUTPUT - AUSGANG	3Ø+N
Uout (Vac)	380/400/415
Iout (A)	122*
Frequenza - Frequency - Frequenz	50÷60Hz
Potenza - Power rating - Leistung	80kVA/80kW (*:@380V)
Icw	6 kA
BATTERIA - BATTERY - BATTERIE	
Udc (Vdc)	+/- 240
Idc (A)	184
N° Serie - Serial Number - Seriennummer	
Year of construction	2017
5th Floor,1# Buiding,Gaofa Industrial Park, Longjing, Nanshan District, Shenzhen, China ,518055	
 Made in China	 150 kg
Service: www.invt-power.com	



2. Rating label for model RM100/25C:

	RM100/25C
UPS	100kVA 3Ø+N
RETE 1 - MAINS 1 - NETZ 1	3Ø+N
U _{in} (Vac)	380/400/415
I _{in} (A)	192*
Frequenza - Frequency - Frequenz	50÷60Hz
RETE 2 - MAINS 2 - NETZ 2	3Ø+N
U _{in} (Vac)	380/400/415
I _{in} (A)	--
Frequenza - Frequency - Frequenz	50÷60Hz
USCITA - OUTPUT - AUSGANG	3Ø+N
U _{out} (Vac)	380/400/415
I _{out} (A)	152*
Frequenza - Frequency - Frequenz	50÷60Hz
Potenza - Power rating - Leistung	100kVA/100kW (*: @380V)
I_{cw}	6 kA
BATTERIA - BATTERY - BATTERIE	
U _{dc} (Vdc)	+/- 240
I _{dc} (A)	226
N° Serie - Serial Number - Seriennumber	
Year of construction	2017
5th Floor,1# Buiding,Gaofa Industrial Park, Longjing, Nanshan District, Shenzhen, China ,518055	
 Made in China	 150 kg
Service: www.invt-power.com	



3. Rating label for model RM120/20C:

	RM120/20C
UPS	120kVA 3Ø+N
RETE 1 - MAINS 1 - NETZ 1	3Ø+N
U _{in} (Vac)	380/400/415
I _{in} (A)	234*
Frequenza - Frequency - Frequenz	50÷60Hz
RETE 2 - MAINS 2 - NETZ 2	3Ø+N
U _{in} (Vac)	380/400/415
I _{in} (A)	--
Frequenza - Frequency - Frequenz	50÷60Hz
USCITA - OUTPUT - AUSGANG	3Ø+N
U _{out} (Vac)	380/400/415
I _{out} (A)	182*
Frequenza - Frequency - Frequenz	50÷60Hz
Potenza - Power rating - Leistung	120kVA/120kW (*:@380V)
I_{cw}	6 kA
BATTERIA - BATTERY - BATTERIE	
U _{dc} (Vdc)	+/- 240
I _{dc} (A)	276
N° Serie - Serial Number - Seriennummer	
Year of construction	2017
5th Floor,1# Buiding,Gaofa Industrial Park, Longjing, Nanshan District, Shenzhen, China ,518055	
 Made in China	 224 kg
Service: www.invt-power.com	



4. Rating label for model RM150/25C

	RM150/25C
UPS	150kVA 3Ø+N
RETE 1 - MAINS 1 - NETZ 1	3Ø+N
U _{in} (Vac)	380/400/415
I _{in} (A)	288*
Frequenza - Frequency - Frequenz	50÷60Hz
RETE 2 - MAINS 2 - NETZ 2	3Ø+N
U _{in} (Vac)	380/400/415
I _{in} (A)	--
Frequenza - Frequency - Frequenz	50÷60Hz
USCITA - OUTPUT - AUSGANG	3Ø+N
U _{out} (Vac)	380/400/415
I _{out} (A)	228*
Frequenza - Frequency - Frequenz	50÷60Hz
Potenza - Power rating - Leistung	150kVA/150kW (*:@380V)
I_{cw}	6 kA
BATTERIA - BATTERY - BATTERIE	
U _{dc} (Vdc)	+/- 240
I _{dc} (A)	339
N° Serie - Serial Number - Seriennumber	
Year of construction	2017
5th Floor,1# Buiding,Gaofa Industrial Park, Longjing, Nanshan District, Shenzhen, China ,518055	
 Made in China	 224 kg
Service: www.invt-power.com	

5. Rating label for model RM160/20C

	RM160/20C
UPS	160kVA 3Ø+N
RETE 1 - MAINS 1 - NETZ 1	3Ø+N
U _{in} (Vac)	380/400/415
I _{in} (A)	312*
Frequenza - Frequency - Frequenz	50÷60Hz
RETE 2 - MAINS 2 - NETZ 2	3Ø+N
U _{in} (Vac)	380/400/415
I _{in} (A)	--
Frequenza - Frequency - Frequenz	50÷60Hz
USCITA - OUTPUT - AUSGANG	3Ø+N
U _{out} (Vac)	380/400/415
I _{out} (A)	243*
Frequenza - Frequency - Frequenz	50÷60Hz
Potenza - Power rating - Leistung	160kVA/160kW (*: @380V)
I_{cw}	6 kA
BATTERIA - BATTERY - BATTERIE	
U _{dc} (Vdc)	+/- 240
I _{dc} (A)	368
N° Serie - Serial Number - Seriennumber	
Year of construction	2017
5th Floor,1# Buiding,Gaofa Industrial Park, Longjing, Nanshan District, Shenzhen, China ,518055	
 Made in China	 344 kg
Service: www.invt-power.com	

6. Rating label for model RM200/25C

	RM200/25C
UPS	200kVA 3Ø+N
RETE 1 - MAINS 1 - NETZ 1	3Ø+N
U _{in} (Vac)	380/400/415
I _{in} (A)	384*
Frequenza - Frequency - Frequenz	50÷60Hz
RETE 2 - MAINS 2 - NETZ 2	3Ø+N
U _{in} (Vac)	380/400/415
I _{in} (A)	--
Frequenza - Frequency - Frequenz	50÷60Hz
USCITA - OUTPUT - AUSGANG	3Ø+N
U _{out} (Vac)	380/400/415
I _{out} (A)	304*
Frequenza - Frequency - Frequenz	50÷60Hz
Potenza - Power rating - Leistung	200kVA/200kW (*: @380V)
I_{cw}	6 kA
BATTERIA - BATTERY - BATTERIE	
U _{dc} (Vdc)	+/- 240
I _{dc} (A)	452
N° Serie - Serial Number - Seriennumber	
Year of construction	2017
5th Floor,1# Buiding,Gaofa Industrial Park, Longjing, Nanshan District, Shenzhen, China ,518055	
 Made in China	 344 kg
Service: www.invt-power.com	

7. Copy of Manufacturer and importer mark

Manufacturer: INVT POWER SYSTEM(SHENZHEN) CO., LTD
 Address: 5th Floor, 1#Building, Gaofa Industrial Park, LongJing,
 Nanshan District, Shenzhen, China, 518055
 Import: xxx
 Address: xxx

8. Warning label on outer enclosures for RM80/20C, RM100/25C, RM120/20C, RM150/25C.

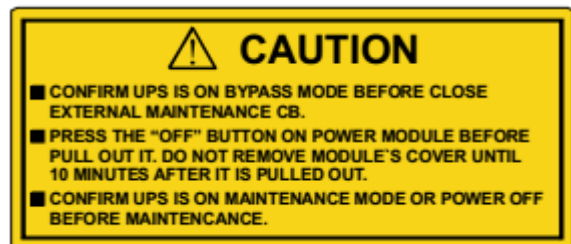
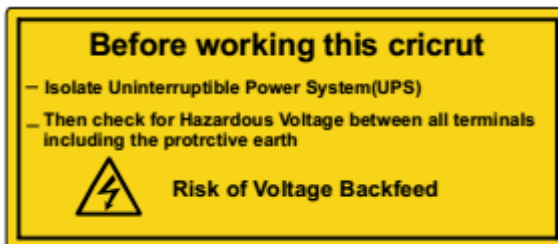
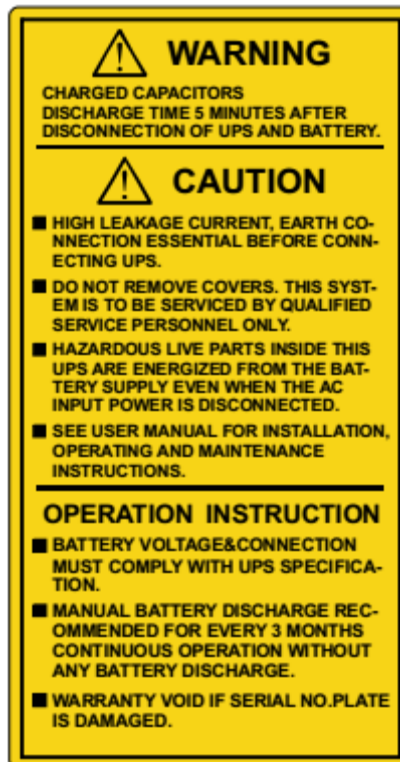

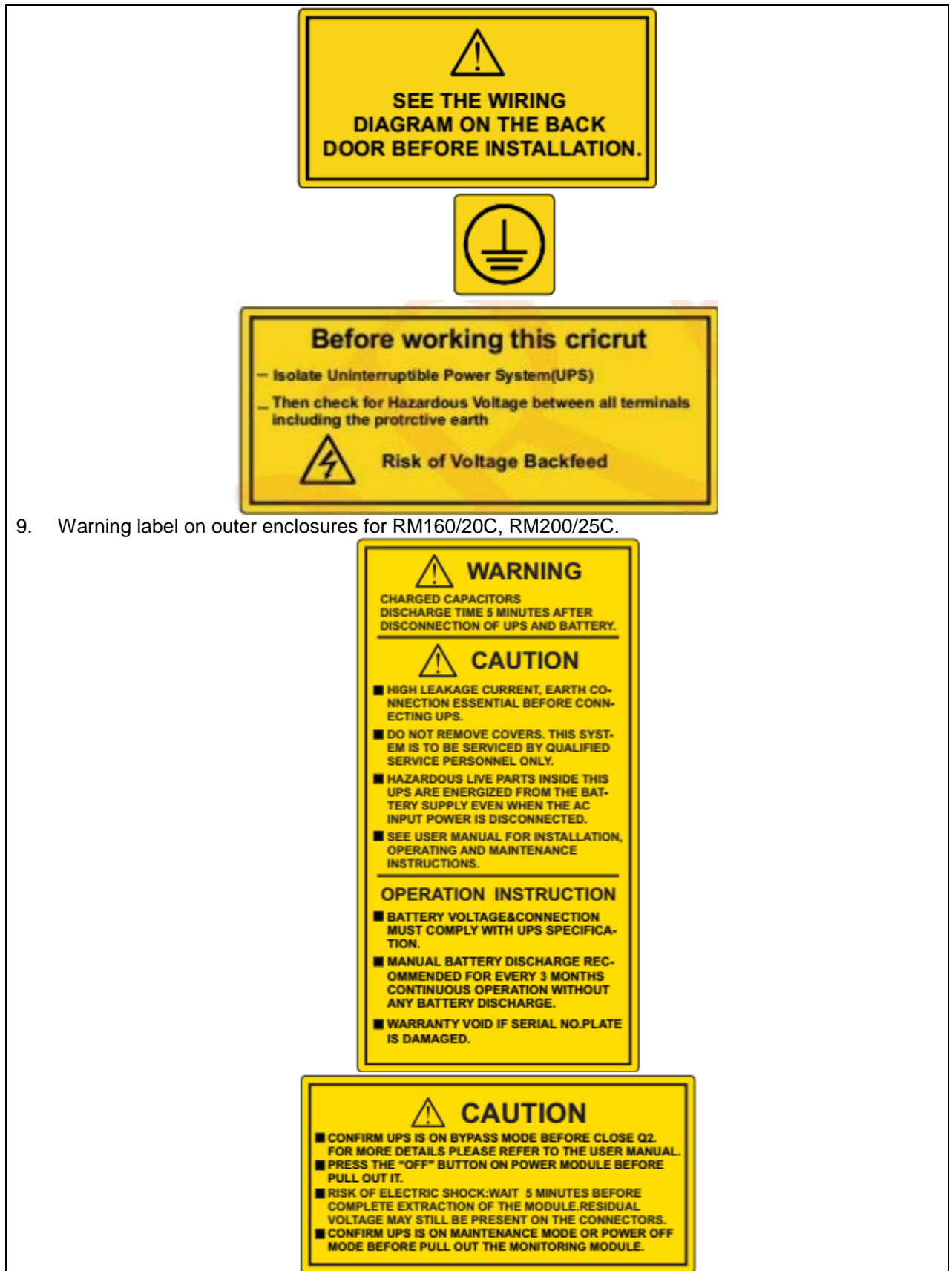

9. Warning label on outer enclosures for RM160/20C, RM200/25C.



Remark:

- The above markings are the minimum requirements required by the safety standard. For the final production samples, the additional markings which do not give rise to misunderstanding may be added.
- The CE marking and WEEE symbol should be at least 5.0 mm and 7.0 mm respectively in height.

Test item particulars:	
Classification of installation and use:	<input checked="" type="checkbox"/> User <input type="checkbox"/> Service Personal
Supply Connection	<input type="checkbox"/> pluggable equipment <input type="checkbox"/> type A <input type="checkbox"/> type B <input checked="" type="checkbox"/> permanent connection <input type="checkbox"/> detachable power supply cord <input type="checkbox"/> non-detachable power supply cord
Equipment mobility	<input type="checkbox"/> movable <input type="checkbox"/> transportable <input checked="" type="checkbox"/> stationary <input type="checkbox"/> for building-in
Operation condition:	<input checked="" type="checkbox"/> continuous <input type="checkbox"/> rated operating / resting time:
Access location:	<input checked="" type="checkbox"/> operator accessible <input type="checkbox"/> restricted access location
Over voltage category (OVC)	<input type="checkbox"/> OVC I <input checked="" type="checkbox"/> OVC II <input type="checkbox"/> OVC III <input type="checkbox"/> OVC IV
Mains supply tolerance (%) or absolute mains supply values	380/400/415Vac+10%,-15% (declared by client)
Tested for IT power systems:	<input type="checkbox"/> Yes <input checked="" type="checkbox"/> No
IT testing, phase-phase voltage (V):	
Class of equipment:	<input checked="" type="checkbox"/> Class I <input type="checkbox"/> Class II <input type="checkbox"/> Not classified
Considered current rating of protective device as part of the building installation (A):	16A
Pollution degree (PD)	<input type="checkbox"/> PD 1 <input checked="" type="checkbox"/> PD 2 <input type="checkbox"/> PD 3
IP protection class:	IP20
Elevation during operation (m):	Up to 2000m
Elevation of test laboratory (m)	Below 2000m
Mass of equipment (kg)	Maximum 344kg
Possible test case verdicts:	
- test case does not apply to the test object.....:	N/A
- test object does meet the requirement.....:	P (Pass)
- test object does not meet the requirement.....:	F (Fail)
Testing:	
Date of receipt of test item	October 10, 2017
Date (s) of performance of tests	October 10, 2017 to October 24, 2017
General remarks:	
"(See Enclosure #)" refers to additional information appended to the report. "(See appended table)" refers to a table appended to the report. Throughout this report a <input type="checkbox"/> comma / <input checked="" type="checkbox"/> point is used as the decimal separator.	

Manufacturer's Declaration per sub-clause 4.2.5 of IEC 60950-1:	
The application for obtaining a CB Test Certificate includes more than one factory location and a declaration from the Manufacturer stating that the sample(s) submitted for evaluation is (are) representative of the products from each factory has been provided	<input type="checkbox"/> Yes <input checked="" type="checkbox"/> Not applicable
When differences exist; they shall be identified in the General product information section.	
Name and address of factory (ies) : Same as applicant	
General product information:	
<p>1. The equipment models RM200/25C series are on line type uninterruptible power supplies with sine wave o/p for general use.</p> <p>2. The input and output circuits and battery circuits of these UPS are considered as primary circuits and isolated from SELV circuit, RS232 port, SNP (optional) and parallel port by either double/reinforced insulation.</p> <p>3. The enclosure consists of metal parts and thermoplastic front panel that is fixed to the metal chassis by screws. The front panel cannot be removed by operator/laymen without tools. Double/reinforced insulation provided where the primary LCD display (plastic cover with min. thickness of 0.4mm used) may be touched and basic insulation provided between primary parts and the reliably earthed metal. The front panel (outer door) is considered as operator accessible area.</p> <p>5. Suitable back feed protect device according to operating instruction should be provided before installation.</p> <p>6. Model difference description: All models are designed with same control logic, constructions, circuit diagram, PCB layout except model name, input rating and output rating, Unless otherwise stated, all tests were performed on model RM200/25C which means the typical model.</p>	

IEC 62040-1			
Clause	Requirement + Test	Result - Remark	Verdict
4	GENERAL CONDITIONS FOR TESTS		P
4.5	Components		P
	Comply with IEC 62040-1 or relevant component standard	Components, which were found to affect safety aspects, comply with the requirements of this standard or within the safety aspects of the relevant IEC component standards. (see appended table 4.5)	P
1.5.2/RD	Evaluation and testing of components	Components, which are certified to IEC and/or national standards, are applied correctly within their ratings. Components not covered by IEC standards are tested under the conditions present in the equipment.	P
1.5.3/RD	Thermal controls	Thermal control not used	N/A
1.5.4/RD	Transformers	Transformers used are suitable for their intended application and comply with the relevant requirements of the standard and particularly Annex C.	P
1.5.5/RD	Interconnecting cables	Not provided.	N/A
1.5.6/RD	Capacitors bridging insulation	Capacitors between primary X2 type capacitor according to IEC 60384-14 used for bridging functional insulation.	P
1.5.7/RD	Resistors bridging insulation		P
1.5.7.1/RD	Resistors bridging functional, basic or supplementary insulation	Resistors only bridging functional insulation	P
1.5.7.2/RD	Resistors bridging double or reinforced insulation between a.c. mains and other circuits		N/A
1.5.7.3/RD	Resistors bridging double or reinforced insulation between a.c. mains and antenna or coaxial cable		N/A
1.5.8/RD	Components in equipment for IT power systems		N/A
4.6	Power interface		P
1.6.1/RD	AC power distribution systems	TN power system	P

IEC 62040-1			
Clause	Requirement + Test	Result - Remark	Verdict
1.6.2/RD	Input current	Highest normal load for this equipment is the charging of empty battery and operation with the maximum specified output load (see appended table 4.6)	P
4.6 1.6.4/RD	Neutral conductor	Basic insulation for rated voltage between earthed parts and line and neutral conductors. O/p neutral is not isolated from the i/p neutral.	P
4.7	Marking and instructions		P
4.7.1	General		P
4.7.2 1.7.1/RD	Power rating	All required markings are affixed on labels located on the enclosure of UPS	P
	Input rated voltage/range (V)	See rating label for details	P
	Input rated current/range (A).....	See rating label for details	P
	Input symbol for nature of supply (d.c.).....	S See rating label for details	N/A
	Input rated frequency/range (Hz).....	50/60 Hz	P
	Number of Input phases and neutral	Three phase, 3Ø+N+PE	P
	Output rated voltage/range (V)	See rating label for details	P
	Output rated current/range (A).....	See rating label for details	P
	Output rated power factor, if less than unity, or active power and apparent power or active power and rated current.....	The active power and apparent power are marked on rating label.	P
	Number of output phases and neutral	Three phase, 3Ø+N+PE	P
	Output rated active power (W or kW)	See rating label for details	P
	Output rated apparent power (VA or kVA)	See rating label for details	P
	Output symbol for nature of supply (d.c.).....	AC outlet provided.	N/A
	Output rated frequency/range (Hz).....	50/60Hz	P
	Ambient operating temperature range (°C).....	Not shown (0-40°C declared by the client)	N/A
	Rated short-time withstand current (I_{cw}) or rated conditional short-circuit current (I_{cc})	lcw: 6kA	P
	Manufacturer's name or trademark or identification mark	See page 1 for details	P
	Type/model or type reference	See page 1 for details	P
	Symbol for Class II equipment only	Class I equipment	N/A

IEC 62040-1			
Clause	Requirement + Test	Result - Remark	Verdict
	Other symbols	Additional symbols or markings do not give rise to misunderstanding.	P
	Certification marks	To be evaluated when subjected to national approval	P
	Instructions for units with automatic bypass/maintenance bypass, additional input a.c. supply, or external batteries, having text "See installation instructions before connecting to the supply"	Instruction provided. See copy of marking plate	P
4.7.3	Safety instructions	See below	P
4.7.3.1	General	"User manual" with directions regarding the maximum ambient temperature, electrical ratings, operation, description of interfaces, connection to the mains. Service personnel installable and to be operated by laymen. Appropriate statements provided in the "User Manual".	P
4.7.3.2	Installation	Installation instructions are available to the user in User's Manual.	P
	Location in a restricted access location only		N/A
	Permanent connector UPS	Installation person and disconnect device instructions are available to the user in User's Manual.	N/A
	Pluggable type A or Pluggable type B UPS	See above	P
4.7.3.3	Operation	The suitable information list in the user manual when operate the UPS.	P
4.7.3.4	Maintenance	The instruction of maintenance is only included in the service manual.	P
4.7.3.5	Distribution related backfeed		N/A
4.7.4 1.7.4/RD	Main voltage adjustment	Single input voltage range	N/A
	Methods and means of adjustment; reference to installation instructions		N/A
4.7.5 1.7.5/RD	Power outlets	No power outlets used in the equipment.	N/A

IEC 62040-1			
Clause	Requirement + Test	Result - Remark	Verdict
4.7.6 1.7.6/RD	Fuse identification (marking, special fusing characteristics, cross-reference)..... :	All fuses and circuit breakers are not located in operator accessible area. Fuse rating placed on the relevant PCB layout and metal enclosure which is nearby the fuse body. Fuse identifications for internal use and other detailed information.	P
4.7.7 1.7.7/RD	Wiring terminals	See below	P
1.7.7.1/RD	Protective earthing and bonding terminals..... :	Only PE of "Normal AC supply" with symbol 60417-1-IEC-5019, others with symbol 60417-1-IEC-5017.	P
1.7.7.2/RD	Terminals for a.c. mains supply conductors :	Terminals provided. Capital letters L1, L2, L3 and N are used to identify input and output phase.	P
1.7.7.3/RD	Terminals for d.c. mains supply conductors :		P
4.7.8	Battery terminals :	Symbol "+" and "-" are used to indicate the polarity of battery connection near the battery terminals.	P
4.7.9 1.7.8/RD	Controls and indicators	See below	P
1.7.8.1/RD	Identification, location and marking :	LCD display provided, located on the front panel to indicate status of UPS, not relevant to safety.	P
1.7.8.2/RD	Colours :	See above. Colours are acceptable due to only used for information (no safety involved even if disregarded).	P
1.7.8.3/RD	Symbols..... :		N/A
1.7.8.4/RD	Markings using figures..... :	Not used.	N/A
4.7.10 1.7.9/RD	Isolation of multiple power sources :	Different connecting method for AC mains and external battery cabinet used, not likely to misconnect. Disconnecting all input (mains connection and battery input) is specified in caution label and user manual	P
4.7.11 1.7.2.4/RD	IT power systems		N/A

IEC 62040-1			
Clause	Requirement + Test	Result - Remark	Verdict
4.7.12	Protection in building installation	Protection against electric shock does not rely on residual current devices.	P
	Rated short-time withstand current (<i>I_{cw}</i>) :		P
	Rated conditional short circuit current (<i>I_{cc}</i>) :		N/A
	a) If higher <i>I_{cp}</i> stated ≤ 10 kA	<i>I_{cw}</i> : 6kA	P
	a) If higher <i>I_{cp}</i> stated > 10 kA		N/A
4.7.13 5.1/RD	High leakage current (mA) :	Leakage current of the equipment does not exceed 3.5 mA. However due to the connected load has influence on the overall earth leakage current a corresponding statement was provided in the user's manual.	N/A
4.7.14 1.7.10/RD	Thermostats and other regulating devices	Neither thermostats nor other regulating devices provided.	N/A
4.7.15 1.7.2.1/RD and 1.7.8.1/RD	Language(s) :	User Manual and markings are both in English. Local language versions will be made available during national approval.	—
4.7.16 1.7.11/RD	Durability of markings	The label was subjected to the permanence of marking test. The label was rubbed with cloth soaked with water for 15 s and then again for 15 s with the cloth soaked with petroleum spirit. After this test there was no damage to the label. The marking on the label did not fade. There was neither curling nor lifting of the label edge.	P
4.7.17 1.7.12/RD	Removable parts	No required markings placed on removable parts.	P
4.7.18 1.7.13/RD	Replaceable batteries	Warning label used	P
	Language(s) :		—
4.7.19 1.7.2.5/RD	Operator access with a tool..... :	Operator is not instructed to use a tool in order to gain access to operator access areas.	N/A

IEC 62040-1			
Clause	Requirement + Test	Result - Remark	Verdict
4.7.20	Battery	UPS's batteries will be located in the external battery cabinet. Specific requirements stated in installation manual.	P
	Clearly legible information..... :	Information clearly legible.	P
	Battery type (lead-acid, NiCd, etc.) and number of blocks or cells..... :	Detailed information regarding to the battery used will be provided in the instruction manual.	P
	Nominal voltage of total battery (V) :	240Vdc(40 blocks)	P
	Nominal capacity of total battery (optional)..... :		N/A
	Warning label :	Considered	P
	Instructions :	Instructions of the UPS with information: <ul style="list-style-type: none"> • Maintenance and disposal instructions • "Caution" statements regarding battery hazards • Remark that servicing shall be performed by personnel knowledgeable of batteries 	P
2.1.1.5/RD	Protection against energy hazards	No risk of energy hazard in operator access area. Hazardous area restricted with metal plate	P
4.7.21 1.7.2.4/RD	Installation instructions	Detailed information regarding external interfaces and connection of supply and loads provided in the user's manual	P

5	FUNDAMENTAL DESIGN REQUIREMENTS		P
5.1	Protection against electric shock and energy hazards		P
5.1.1 2.1.1/RD	Protection for UPS intended to be used in operator access areas	No hazardous voltage circuit wiring can be accessed by operator.	P
2.1.1.1/RD	Access to energized parts	No hazardous voltage circuit wiring can be accessed by operator.	P
	Test by inspection..... :		P

IEC 62040-1			
Clause	Requirement + Test	Result - Remark	Verdict
	Test with test finger (Figure 2A)..... :	The test pin can not touch hazardous voltage through any seams within the appliance.	P
	Test with test pin (Figure 2B)..... :	The test probe cannot touch contacts of LINE port.	P
	Test with test probe (Figure 2C)..... :		N/A
2.1.1.2/RD	Battery compartments	No TNV circuits exist inside battery compartments	N/A
2.1.1.3/RD	Access to ELV wiring	No ELV wiring in operator accessible area.	N/A
	Working voltage (V_{peak} or V_{rms}); minimum distance through insulation (mm)		—
2.1.1.4/RD	Access to hazardous voltage circuit wiring	No any hazardous voltage circuit wiring operator accessible.	P
2.1.1.5/RD	Energy hazards..... :	No energy hazard at operator accessible area. No energy hazard during battery replacement for service person due to shape of battery terminals.	P
2.1.1.6/RD	Manual controls	No conductive controls or handles or alike provided.	N/A
2.1.1.7/RD	Discharge of capacitors in equipment		P
	Measured voltage (V); time-constant (s)..... :	(See appended table 5.1.1 and 2.1.1.7/RD)	—
2.1.1.8/RD	Energy hazards – d.c. mains supply		N/A
	a) Capacitor connected to the d.c. mains supply ... :		N/A
	b) Internal battery connected to the d.c. mains supply..... :		N/A
2.1.1.9/RD	Audio amplifiers in information technology equipment..... :		N/A
5.1.2 2.1.1.5 c) /RD	Protection for UPS intended to be used in service access areas		N/A
	Hazardous energy level..... :		N/A
5.1.3 2.1.1.5 c) /RD	Protection for UPS intended to be used in restricted access areas		N/A
	Hazardous energy level..... :		N/A

IEC 62040-1			
Clause	Requirement + Test	Result - Remark	Verdict
5.1.4	Backfeed protection	Backfeed protection such as contactor will be provided external to the UPS in the final installation which is also specified in installation manual	N/A
	Shock hazard after de-energization of a.c. input for UPS		N/A
	Measured voltage (V); time-constant (s)		—
	Description of the construction		N/A
	Air gap is employed for backfeed protection		N/A
5.1.5	Emergency switching (disconnect) device	REPO dry contactor provided, which is used to shutdown the UPS in case of emergency.	P
5.2	Requirements for auxiliary circuits		P
5.2.1 2.2/RD	Safety extra low voltage circuit - SELV	EPO, USB and RS232 port is considered as SELV circuit	P
2.2.1/RD	General requirements	All SELV circuits within limits.	P
2.2.2/RD	Voltages under normal conditions (V)	(See appended table 5.2.1)	P
2.2.3/RD	Voltages under fault conditions (V).....	(See appended table 5.2.1)	P
2.2.4/RD	Connection of SELV circuits to other circuits.....	To SELV only	P
5.2.2 2.3/RD	Telephone network voltage circuits - TNV	No TNV circuit.	N/A
2.3.1/RD	Limits		N/A
	Type of TNV circuits		—
2.3.2/RD	Separation of TNV circuits from other circuits and from accessible parts		N/A
2.3.2.1/RD	General requirements		N/A
2.3.2.2/RD	Protection by basic insulation		N/A
2.3.2.3/RD	Protection by earthing		N/A
2.3.2.4/RD	Protection by other constructions		N/A
2.3.3/RD	Separation from hazardous voltages		N/A
	Insulation employed.....		—
2.3.4/RD	Connection of TNV circuits to other circuits		N/A
	Insulation employed.....		—
2.3.5/RD	Test for operating voltages generated externally		N/A
5.2.3 2.4/RD	Limited current circuits		N/A
2.4.1/RD	General requirements		N/A

IEC 62040-1			
Clause	Requirement + Test	Result - Remark	Verdict
2.4.2/RD	Limit values		—
	Frequency (Hz)		—
	Measured current (mA)		—
	Measured voltage (V)		—
	Measured circuit capacitance (nF or μ F)		—
2.4.3/RD	Connection of limited current circuits to other circuits		N/A
5.2.4 3.5/RD	External signaling circuits	EPO, USB, RS485 and RS232 port is considered as SELV circuit	P
3.5.1/RD	General requirements		P
3.5.2/RD	Types of interconnection circuits	See above.	P
3.5.3/RD	ELV circuits as interconnection circuits		N/A
3.5.4/RD	Data ports for additional equipment	See above.	N/A
5.2.5 2.5/RD	Limited power source		N/A
	a) Inherently limited output		N/A
	b) Impedance limited output		N/A
	c) Regulating network limited output under normal operating and single fault condition		N/A
	d) Overcurrent protective device limited output		N/A
	Max. output voltage (V), max. output current (A), max. apparent power (VA)		—
	Current rating of overcurrent protective device (A) :		—
	Use of integrated circuit (IC) current limiters		—
5.3	Protective earthing and bonding		P
5.3.1	General		P
2.6/RD	Provisions for earthing and bonding	See below	P
2.6.1/RD	Protective earthing	Reliable connection from the protective bonding terminal on outlet to the PE terminal (AC plug) via green/yellow insulated wires.	P
2.6.2/RD	Functional earthing		N/A
2.6.3/RD	Protective earthing conductors and protective bonding conductors	See below	P
2.6.3.1/RD	General	See subclause 2.6.3.3/RD	P

IEC 62040-1			
Clause	Requirement + Test	Result - Remark	Verdict
2.6.3.2/RD	Size of protective earthing conductors	Permanent connection. For input terminals, the size of protective earthing conductor shall be selected according to installation manual.	P
	Rated current (A), cross-sectional area (mm ²), AWG	384A max, >16mm ² . to be provided	—
2.6.3.3/RD	Size of protective bonding conductors	UPS metal frame works as protective bonding conductor, is considered to be sufficient (comply with table 3B of 3.2.5/RD) for the current under earth fault.	P
	Rated current (A), cross-sectional area (mm ²), AWG		—
	Protective current rating (A), cross-sectional area (mm ²), AWG		—
2.6.3.4/RD	Resistance of earthing conductors and their terminations; resistance (Ω), voltage drop (V), test current (A), duration (min)	(See appended table 5.3.1)	P
2.6.3.5/RD	Colour of insulation	Green/yellow	P
2.6.4/RD	Terminals	See above	P
2.6.4.1/RD	General		P
2.6.4.2/RD	Protective earthing and bonding terminals	Adequate protective earth connection, see also Sub-clause 2.6.3.4/RD and 3.3/RD	P
	Rated current (A), type, nominal thread diameter (mm).....		—
2.6.4.3/RD	Separation of the protective earthing conductor from protective bonding conductors	Protective bonding conductor is used from the input terminal to the metal chassis, separate bonding terminal used to connect the bonding conductor between different output terminals and metal frame of the UPS.	P
2.6.5/RD	Integrity of protective earthing	See below	P
2.6.5.1/RD	Interconnection of equipment	This unit has it's own earthing connection. PE terminals of outlets reliably connected to earthing pin of inlet.	P
2.6.5.2/RD	Components in protective earthing conductors and protective bonding conductors	No switch or overcurrent protective device in protective bonding conductors.	P

IEC 62040-1			
Clause	Requirement + Test	Result - Remark	Verdict
2.6.5.3/RD	Disconnection of protective earth	Permanently equipment no disconnection.	P
2.6.5.4/RD	Parts that can be removed by an operator	Permanent connection, no parts can be removed by operator.	N/A
2.6.5.5/RD	Parts removed during servicing	It is not necessary to disconnect earthing except for the removal of the earthed part itself.	P
2.6.5.6/RD	Corrosion resistance	All safety earthing connections in compliance with Annex J.	P
2.6.5.7/RD	Screws for protective bonding	Protective bonding conductors connected to metal chassis via ring-type lugs fixed to metal studs (ISO thread type M10, with nut and star-washer provided	P
2.6.5.8/RD	Reliance on telecommunication network or cable distribution system		N/A
5.3.2 2.6.1/RD	Protective earthing	See 2.6.3/RD and 2.6.4/RD.	P
2.10/RD	Clearances, creepage distances and distances through insulation	(see appended table 5.7)	P
4.2/RD	Mechanical strength		P
5.2/RD	Electric strength	(see appended table 8.2)	P
5.3.3	Protective bonding	See above	P
5.4	AC and d.c. power isolation		P
5.4.1	General		P
3.4/RD	Disconnection from the mains supply		P
3.4.1/RD	General requirement		P
3.4.2/RD	Disconnect devices	For permanent connection type, according to installation instruction, suitable circuit breaker external to the UPS will be installed as disconnect device.	P
3.4.3/RD	Permanently connected equipment	External disconnect should be provide.	P
3.4.4/RD	Parts which remain energized	Adequate protection provided to service personnel during backup mode.	P
3.4.5/RD	Switches in flexible cords	None provided.	N/A
3.4.6/RD	Number of poles - single-phase and d.c. equipment	Three phase equipment	P

IEC 62040-1			
Clause	Requirement + Test	Result - Remark	Verdict
3.4.7/RD	Number of poles - three-phase equipment	3 pole switch will be used as disconnected device for whole system and it is optional to the UPS, Adequate disconnection information regarding the disconnection switch for the configuration without the integrated disconnection switch for whole unit was already stated in the final installation	P
3.4.8/RD	Switches as disconnect devices	Relevant indication provided on the body of disconnection switch	P
3.4.9/RD	Plugs as disconnect devices		N/A
3.4.10/RD	Interconnected equipment	Hazardous Voltage circuits to Hazardous circuits.	P
3.4.11/RD	Multiple power sources	Instructions provided at every switch, see "Copies of markings and warnings".	P
5.4.2	Disconnect devices		P
5.5	Overcurrent and earth fault protection		P
5.5.1	General		P
2.7.3/RD	Short-circuit backup protection	Over current protection by built-in fuses in each of 3 phases. Permanently Connected Equipment. Building Installation is provide short-circuit backup protection.	P
2.7.4/RD	Number and location of protective devices :	Over current protector provided in live conductor	P
2.7.5/RD	Protection by several devices	Three fuse in parallel protection device provided. No protective device in neutral.	P
2.7.6/RD	Warning to service personnel :	No double-pole fusing inside this pluggable equipment type A UPS.	N/A
5.5.2	Basic requirements	Equipment relies on fuse or circuit breaker of the wall outlet protection of the building installation in regard to L to N short-circuit. Over current protection is provided by the built-in fuse.	P

IEC 62040-1			
Clause	Requirement + Test	Result - Remark	Verdict
5.5.3	Battery circuit protection	External battery cabinet is not provided with UPS. Protection shall be provided in battery cabinet.	P
5.5.3.1	Overcurrent and earth fault protection	Battery fuses are directly located behind the supply wire terminals to the external battery cabinets The charger circuit is located in front of the fuse. For the charger circuit there are no hazardous situations under any simulated fault conditions. (see appended table 8.3).	P
5.5.3.2	Location of protective device	See above.	P
5.5.3.3	Rating of protective device	Protection against overcurrent by Fuse.	P
5.3.1/RD	Protection against overload and abnormal operation	(see appended table 8.3)	P
5.5.4	Short-time withstand current	lcw:6kA	N/A
5.5.4.1	General		N/A
5.5.4.2	Modes of operation		N/A
5.5.4.3	Test procedure		N/A
5.5.4.3.1	General application		N/A
	Rated UPS output current/(r.m.s) (A)..... :		—
	Prospective test current/(r.m.s) (A)..... :		—
	Typical power factor..... :		—
	Initial asymmetric peak current ration (I_{pk} / I_{cw}) :		—
	Minimum duration of prospective test current (cycles 50/60 Hz) :		—
5.5.4.3.2	Exemption from testing	Specified I_{cc} / I_{cw} not exceed 10kA, no test necessary.	P
5.6	Protection of personnel – Safety interlocks		P
5.6.1	Operator protection	No hazardous voltage levels in operator accessible areas.	P
2.8/RD	General principles		N/A
2.8.1/RD	Protection requirements		N/A
2.8.2/RD	Inadvertent reactivation		N/A
2.8.3/RD	Fail-safe operation		N/A
2.8.4/RD	Protection against extreme hazard		N/A
2.8.5/RD	Moving parts		N/A

IEC 62040-1			
Clause	Requirement + Test	Result - Remark	Verdict
2.8.6/RD	Overriding		N/A
2.8.7/RD	Switches, relays and their related circuits		N/A
2.8.7.1/RD	Separation distances for contact gaps and their related circuits		N/A
2.8.7.2/RD	Overload test		N/A
2.8.7.3/RD	Endurance test		N/A
2.8.7.4/RD	Electric strength test	(see appended table 8.2)	N/A
2.8.8/RD	Mechanical actuators		N/A
5.6.2	Service person protection		N/A
5.6.2.1	Introduction		N/A
5.6.2.2	Covers		N/A
5.6.2.3	Location and guarding of parts		N/A
5.6.2.4	Parts on doors		N/A
5.6.2.5	Component access		N/A
2.8.3/RD	Fail-safe operation		N/A
5.6.2.6	Moving parts		N/A
5.6.2.7	Capacitor banks		N/A
5.6.2.8	Internal batteries	Risk of short-circuiting minimized by design of used battery source and corresponding terminals and wiring methods used.	P
5.7 2.10/RD	Clearances, creepage distances and distances through insulation		P
2.10.1/RD	General	See 2.10.3, 2.10.4 and 2.10.5.	P
2.10.1.1/RD	Frequency.....	Considered	P
2.10.1.2/RD	Pollution degrees	2	P
2.10.1.3/RD	Reduced values for functional insulation	See 5.3.4.	N/A
2.10.1.4/RD	Intervening unconnected conductive parts	No such part.	N/A
2.10.1.5/RD	Insulation with varying dimensions	No such transformer used.	N/A
2.10.1.6/RD	Special separation requirements		P
2.10.1.7/RD	Insulation in circuits generating starting pulses	No such circuit.	N/A
2.10.2/RD	Determination of working voltage		P

IEC 62040-1			
Clause	Requirement + Test	Result - Remark	Verdict
2.10.2.1/R D	General	The rms and the peak voltage were measured with unit connected to a 240V/415V(Three phase) TN power system. Pollution Degree 2 and Overvoltage Category II considered.	P
2.10.2.2/R D	RMS working voltage	(See appended table 5.7)	P
2.10.2.3/R D	Peak working voltage	(See appended table 5.7)	P
2.10.3/RD	Clearances	See below and advantage of annex G is not considered.	P
2.10.3.1/R D	General	Considered.	P
2.10.3.2/R D	Mains transient voltages		P
	a) AC mains supply..... :	240V a.c. and Overvoltage Category II	P
	b) Earthed d.c. mains supplies		N/A
	c) Unearthed d.c. mains supplies		N/A
	d) Battery operation		N/A
2.10.3.3/R D	Clearances in primary circuits	(see appended table 5.7)	P
2.10.3.4/R D	Clearances in secondary circuits	Sub-clause 5.3.4 considered.	P
2.10.3.5/R D	Clearances in circuits having starting pulses		N/A
2.10.3.6/R D	Transients from a.c. mains supply..... :	Normal transient voltage considered (overvoltage category II for primary circuit).	P
2.10.3.7/R D	Transients from d.c. mains supply..... :		N/A
2.10.3.8/R D	Transients from telecommunication networks and cable distribution systems		N/A
2.10.3.9/R D	Measurement of transient voltage levels		N/A
	a) Transients from a mains supply		N/A
	For an a.c. mains supply		N/A
	For a d.c. mains supply		N/A
	b) Transients from a telecommunication network...		N/A

IEC 62040-1			
Clause	Requirement + Test	Result - Remark	Verdict
2.10.4/RD	Creepage distances	(see appended table 5.7)	P
2.10.4.1/RD	General		P
2.10.4.2/RD	Material group and comparative tracking index		P
	CTI tests	Material group IIIb is assumed to be used.	P
2.10.4.3/RD	Minimum creepage distances	(see appended table 5.7)	P
2.10.5 /RD	Solid insulation		P
2.10.5.1/RD	General	See below	P
2.10.5.2/RD	Distances through insulation	(see appended table 5.7)	P
2.10.5.3/RD	Insulating compound as solid insulation		N/A
2.10.5.4/RD	Semiconductor devices	Approved optocoupler used.	P
2.10.5.5/RD	Cemented joints	No such construction.	N/A
2.10.5.6/RD	Thin sheet material – General	Ref. to sub-clause 2.10.5.1/RD and Annex C	P
2.10.5.7/RD	Separable thin sheet material		P
	Number of layers (pcs)		—
2.10.5.8/RD	Non-separable thin sheet material		N/A
2.10.5.9/RD	Thin sheet material – standard test procedure		N/A
	Electric strength test		—
2.10.5.10 /RD	Thin sheet material – alternative test procedure		P
	Electric strength test	(See appended table 5.8)	—
2.10.5.11 /RD	Insulation in wound components	Approved triple insulated wire used as secondary winding of T1	P
2.10.5.12 /RD	Wire in wound components	No wound components used.	N/A
	Working voltage	(see appended table 2.10.2)	—
	a) Basic insulation not under stress		N/A
	b) Basic, supplementary, reinforced insulation.....		N/A

IEC 62040-1			
Clause	Requirement + Test	Result - Remark	Verdict
	c) Compliance with Annex U..... :	Complied	P
	Two wires in contact inside wound component; angle between 45° and 90°..... :	Insulation tube are provided to release the tension.	P
2.10.5.13 /RD	Wire with solvent-based enamel in wound components	No such construction.	N/A
	Electric strength test		—
	Routine test		N/A
2.10.5.14 /RD	Additional insulation in wound components	No such construction.	N/A
	Working voltage..... :		—
	- Basic insulation not under stress..... :		N/A
	- Supplementary, reinforced insulation..... :		N/A
2.10.6/RD	Construction of printed boards	See below	P
2.10.6.1/R D	Uncoated printed boards	(See appended table 5.7)	P
2.10.6.2/R D	Coated printed boards	No coated printed boards.	N/A
2.10.6.3/R D	Insulation between conductors on the same inner surface of a printed board	No multi-layer PCBs provided.	N/A
2.10.6.4/R D	Insulation between conductors on different layers of a printed board	No multi-layer PCBs provided.	N/A
	Distance through insulation		N/A
	Number of insulation layers (pcs)..... :	Single layer PCB	N/A
2.10.7/RD	Component external terminations	(See appended table 5.7)	P
2.10.8/RD	Tests on coated printed boards and coated components	No such boards and components	N/A
2.10.8.1/R D	Sample preparation and preliminary inspection		N/A
2.10.8.2/R D	Thermal conditioning		N/A
2.10.8.3/R D	Electric strength test	(see appended table 8.2)	—
2.10.8.4/R D	Abrasion resistance test		N/A
2.10.9/RD	Thermal cycling		N/A
2.10.10/R D	Test for Pollution Degree 1 environment and insulating compound		N/A
2.10.11/R D	Tests for semiconductor devices and cemented joints	See only 2.10.5.4/RD regards approved optocouplers	N/A

IEC 62040-1			
Clause	Requirement + Test	Result - Remark	Verdict
2.10.12/R D	Enclosed and sealed parts	No hermetically sealed component.	N/A

6	Wiring, connections and supply		P
6.1	General		P
6.1.1	Introduction		P
3.1/RD	General		P
3.1.1/RD	Current rating and overcurrent protection	Internal wires are UL recognized wiring which is PVC insulated, rated VW-1 or FT-1, and having gauge suitable for current intended to be carried.	P
3.1.2/RD	Protection against mechanical damage	Wires do not touch sharp edges which could damage the insulation and cause hazard.	P
3.1.3/RD	Securing of internal wiring	Internal wires are secured by solder pins, cable ties and quick connect terminals so that a loosening of the terminal connection is unlikely.	P
3.1.4/RD	Insulation of conductors	The insulation of the individual conductors is suitable for the application and the working voltage. For the insulation material see subclause 3.1.1/RD.	P
3.1.5/RD	Beads and ceramic insulators	Not used.	N/A
3.1.6/RD	Screws for electrical contact pressure	No such screws provided.	N/A
3.1.7/RD	Insulating materials in electrical connections	All current carrying connections are metal to metal.	P
3.1.8/RD	Self-tapping and spaced thread screws	Not used.	N/A
3.1.9/RD	Termination of conductors	All conductors are reliable secured.	P
	10 N pull test	Force of 10 N applied to the termination points of the conductors.	P
3.1.10/RD	Sleeving on wiring	Heat shrinkable tube used on the wire connector point.	P
6.1.2	Dimensions and rating of busbars and insulated conductors		N/A

IEC 62040-1			
Clause	Requirement + Test	Result - Remark	Verdict
6.2	Connection to power		P
6.2.1	General provisions for connection to power		P
3.2.2/RD	Multiple supply connections	Terminals for permanent connection.	P
3.2.3/RD	Permanently connected equipment	For permanent connection type, terminals for permanent connection to supply.	P
	Number of conductors, diameter of cable and conduits (mm)		—
3.2.4/RD	Appliance inlets	Not used.	N/A
3.2.5/RD	Power supply cords	No power supply cord is supplied.	N/A
3.2.5.1/RD	AC power supply cords		N/A
	Type		—
	Rated current (A), cross-sectional area (mm ²), AWG		—
3.2.5.2/RD	DC power supply cords		N/A
3.2.6/RD	Cord anchorages and strain relief		N/A
	Mass of equipment (kg), pull (N).....		—
	Longitudinal displacement (mm).....		—
3.2.7/RD	Protection against mechanical damage	No parts under this unit likely to damage the power supply cord. No sharp edge	P
3.2.8/RD	Cord guards		N/A
	Diameter or minor dimension D (mm); test mass (g)		—
	Radius of curvature of cord (mm)		—
6.2.2	Means of connection	Wiring terminals used.	P
	More than one supply connection.....	AC mains and external battery cabinet used. Terminals for the battery not compatible with AC mains.	P
6.3	Wiring terminals for external power conductors		P
3.3/RD	Wiring terminals for connection of external conductors		P
3.3.1/RD	Wiring terminals		P
3.3.2/RD	Connection of non-detachable power supply cords		N/A
3.3.3/RD	Screw terminals	Screws and nuts conforming to ISO 261 or ISO 262 input terminal	P

IEC 62040-1			
Clause	Requirement + Test	Result - Remark	Verdict
3.3.4/RD	Conductor sizes to be connected	Conductor size will be connected according to installation manual.	P
	Rated current (A), cord/cable type, cross-sectional area (mm ²)..... :	For Phase/Neutral/Battery/PE conductors. See instruction manual for the configuration for all models	—
3.3.5/RD	Wiring terminal sizes		P
	Rated current (A), type, nominal thread diameter (mm)..... :		—
3.3.6/RD	Wiring terminal design		N/A
3.3.7/RD	Grouping of wiring terminals		N/A
3.3.8/RD	Stranded wire		N/A

7	Physical requirements		P
7.1	Enclosure	Plastic enclosure. Enclosure completely enclosing hazardous parts.	P
7.2 4.1/RD	Stability		P
	Angle of 10°	The UPS does not overturn when: tilted to an angle of 10° use a constant downward force of 800N a force of 20% of the weight is applied from any direction.	P
	Test force (N)	See above	P
7.3 4.2/RD	Mechanical strength		P
4.2.1/RD	General	Tests performed and passed. Results see below. After tests, unit complied with the requirements of sub-clauses 2.1.1/RD, 2.6.1/RD and 2.10/RD.	P
4.2.2/RD	Steady force test, 10 N	10 N applied to all components other than enclosure.	—
4.2.3/RD	Steady force test, 30 N		N/A

IEC 62040-1			
Clause	Requirement + Test	Result - Remark	Verdict
4.2.4/RD	Steady force test, 250 N	250 N applied to outer enclosure.	P
4.2.5/RD	Impact test	See below	P
	Fall test	No hazard as result from steel ball fall test.	P
	Swing test	No hazard as result from steel ball swing test.	P
4.2.6/RD	Drop test; height (mm)..... :	Not required for this equipment.	N/A
4.2.7/RD	Stress relief test	Tested at temperature of 70°C. No distortion of enclosure observed and no hazards.	—
4.2.8/RD	Cathode ray tubes	No CRT in the unit.	N/A
	Picture tube separately certified :		—
4.2.9/RD	High pressure lamps	No high pressure lamp provided.	N/A
4.2.10/RD	Wall or ceiling mounted equipment; force (N) :	Not wall mounted equipment.	N/A
7.4	Construction details		P
7.4.1	Introduction		P
4.3.1/RD	Edges and corners	Edges and corners of the enclosure are rounded.	P
4.3.2/RD	Handles and manual controls; force (N)..... :	No handles or manual controls provided. No axial pull applied to push-buttons.	N/A
4.3.3/RD	Adjustable controls		N/A
4.3.4/RD	Securing of parts	Mechanical fixings in such a way designed that they will withstand mechanical stress occurring in normal use.	P
4.3.5/RD	Connection by plugs and sockets	No mismatching of connectors, plugs or sockets possible.	P
4.3.7/RD	Heating elements in earthed equipment		N/A
4.3.11/RD	Containers for liquids or gases		N/A
4.4/RD	Protection against hazardous moving parts		N/A
4.4.1/RD	General	Fan for skilled person only, cannot be touched.	P
4.4.2/RD	Protection in operator access areas..... :	See above	P
4.4.3/RD	Protection in restricted access locations..... :	See above	P
4.4.4/RD	Protection in service access areas	See above	P

IEC 62040-1			
Clause	Requirement + Test	Result - Remark	Verdict
4.4.5/RD	Protection against moving fan blades		N/A
4.4.5.1/RD	General		N/A
	Not considered to cause pain or injury. a) :		N/A
	Is considered to cause pain, not injury. b) :		N/A
	Considered to cause injury. c) :	Considered	P
4.4.5.2	Protection for users		N/A
	Use of symbol or warning..... :		N/A
4.4.5.3	Protection for service persons		N/A
	Use of symbol or warning..... :	Instructed in the service instructions	N/A
4.5/RD	Thermal requirements	See clause 7.7	P
4.5.1/RD	General		P
4.5.2/RD	Temperature tests		P
	Normal load condition per Annex L :	Equipment loaded with rated output power.	P
4.5.3/RD	Temperature limits for materials	(see appended table 7.7)	P
4.5.4/RD	Touch temperature limits	(see appended table 7.7)	P
4.5.5/RD	Resistance to abnormal heat :	(see appended table 7.4)	P
7.4.2	Openings	See appended table 7.4.2	P
7.4.3	Gas Concentration	For the ventilation of the lead-acid battery refer to table M	P
7.4.4	Equipment movement	No castors provided.	N/A
7.5	Resistance to fire		P
4.7/RD			
4.7.1/RD	Reducing the risk of ignition and spread of flame		P
	Method 1, selection and application of components wiring and materials	(see appended table 7.5)	P
	Method 2, application of all of simulated fault condition tests	(see appended table 7.5)	P
4.7.2/RD	Conditions for a fire enclosure		P

IEC 62040-1			
Clause	Requirement + Test	Result - Remark	Verdict
4.7.2.1/RD	Parts requiring a fire enclosure	With having the following components: a) Components in primary circuits c) Insulated wiring Semiconductor devices, transistors, diodes, integrated circuits d) Resistors, capacitors, inductors The fire enclosure is required.	P
4.7.2.2/RD	Parts not requiring a fire enclosure		N/A
4.7.3/RD	Materials		P
4.7.3.1/RD	General	See below	P
4.7.3.2/RD	Materials for fire enclosures	Metal enclosure with plastic front panel.	P
4.7.3.3/RD	Materials for components and other parts outside fire enclosures		N/A
4.7.3.4/RD	Materials for components and other parts inside fire enclosures	PCB rated V-0 or better. See appended table 4.5 for details. Internal components except small parts are V-2 or better.	P
4.7.3.5/RD	Materials for air filter assemblies	No air filters provided.	N/A
4.7.3.6/RD	Materials used in high-voltage components	No high voltage components provided.	N/A
7.6	Battery location		P
7.6.1	Battery location and installation	Battery location and installation of the external battery cabinet and internal battery are described in detail.	P
7.6.2	Accessibility and maintainability	No requirements declared by the battery manufacturer.	N/A
7.6.3	Distance	The temperature of the electrolyte and the gas emission are within the limits of this standard (see appropriate subclauses).	P
7.6.4	Case insulation	No Ni-Cd battery used inside.	N/A
7.6.5	Wiring	The protection of connection wiring complies with subclause 3/RD.	P

IEC 62040-1			
Clause	Requirement + Test	Result - Remark	Verdict
7.6.6	Electrolyte spillage	Sealed maintenance free batteries provided with an unlikely emission of electrolyte (VRLA type).	P
7.6.7	Ventilation	For the ventilation of the lead-acid battery refer to table M.	P
7.6.8	Charging voltage	See appended table 8.3.	P
7.7	Temperature rise		P
4.5/RD	Thermal requirements		P
4.5.1/RD	General		P
4.5.2/RD	Temperature tests	(see appended table 7.7)	P
	Normal load condition per Annex L		P
4.5.3/RD	Temperature limits for materials	(see appended table 7.7)	P
4.5.4/RD	Touch temperature limits	(see appended table 7.7)	P
4.5.5/RD	Resistance to abnormal heat	Phenolic material	P

8	Electrical requirements and simulated abnormal conditions		P
8.1	General provisions for earth leakage		P
5.1.1/RD	General	Total touch current is depending on interconnected equipment	P
5.1.7/RD	Equipment with touch current exceeding 3,5 mA	Warning label used	P
8.2	Electric strength		P
5.2/RD			
5.2.1/RD	General	(see appended table 8.2)	P
5.2.2/RD	Test procedure	(see appended table 8.2)	P
8.3	Abnormal operating and fault conditions		P
8.3.1	General		P
5.3.1/RD	Protection against overload and abnormal operation	(see appended table 8.3)	P
5.3.2/RD	Motors	Approved DC fans used. Also test in appliance	P
5.3.3/RD	Transformers	(see appended Annex C)	P
5.3.4/RD	Functional insulation	By short-circuited, results see appended table 8.3.	P
5.3.5/RD	Electromechanical components	No electromechanical component (except for approved relays) provided.	P

IEC 62040-1			
Clause	Requirement + Test	Result - Remark	Verdict
5.3.9/RD	Compliance criteria for abnormal operating and fault conditions	No fire propagated beyond the equipment. No molten metal was emitted. Electric strength tests from primary to SELV and primary to PE were passed.	P
5.3.9.1/RD	During the tests		P
5.3.9.2/RD	After the tests		P
8.3.2	Simulation of faults	No fire or molten metal occurred and no deformation of enclosure during the tests.	P
8.3.3	Conditions for tests	No reduction of clearance and creepage distance. Electric strength test is made on basic, supplementary and reinforced insulation after test.	P

9 6/RD	Connection to telecommunication networks		N/A
6.1/RD	Protection of telecommunication network service persons, and users of other equipment connected to the network, from hazards in the equipment		N/A
6.1.1/RD	Protection from hazardous voltages		N/A
6.1.2/RD	Separation of the telecommunication network from earth		N/A
6.1.2.1/RD	Requirements		N/A
	Supply voltage (V)	:	—
	Current in the test circuit (mA)	:	—
6.1.2.2/RD	Exclusions	:	N/A
6.2/RD	Protection of equipment users from overvoltages on telecommunication networks		N/A
6.2.1/RD	Separation requirements		N/A
6.2.2/RD	Electric strength test procedure		N/A
6.2.2.1/RD	Impulse test		N/A
6.2.2.2/RD	Steady-state test		N/A
6.2.2.3/RD	Compliance criteria		N/A
6.3/RD	Protection of the telecommunication wiring system from overheating		N/A
	Max. output current (A)	:	—
3.5/RD	Interconnection of equipment		N/A
3.5.1/RD	General requirements		N/A

IEC 62040-1			
Clause	Requirement + Test	Result - Remark	Verdict
3.5.2/RD	Types of interconnection circuits		N/A
3.5.3/RD	ELV circuits as interconnection circuits		N/A
3.5.4/RD	Data ports for additional equipment		N/A
2.1.3/RD	Protection in restricted access locations		N/A
2.3.1/RD	Limits		N/A
	Type of TNV circuits		—
2.3.2/RD	Separation from other circuits and from accessible parts		N/A
2.3.2.1/RD	General requirements		N/A
2.3.2.2/RD	Protection by basic insulation		N/A
2.3.2.3/RD	Protection by earthing		N/A
2.3.2.4/RD	Protection by other constructions		N/A
2.3.3/RD	Separation from hazardous voltages		N/A
	Insulation employed.....		—
2.3.4/RD	Connection of TNV circuits to other circuits		N/A
	Insulation employed.....		—
2.3.5/RD	Test for operating voltages generated externally		N/A
2.6.5.8/RD	Reliance on telecommunication network or cable distribution system		N/A
2.10.3.3/RD	Clearances in primary circuits		N/A
2.10.3.4/RD	Clearances in secondary circuits		N/A
2.10.4/RD	Creepage distances		N/A
2.10.4.1/RD	General		N/A
2.10.4.2/RD	Material group and comparative tracking index		N/A
	CTI tests		—
2.10.4.3/RD	Minimum creepage distances		N/A
M/RD	Annex M, CRITERIA FOR TELEPHONE RINGING SIGNALS (see 2.3.1/RD)		N/A
M.1/RD	Introduction		N/A
M.2 /RD	Method A		N/A
M.3/RD	Method B		N/A
M.3.1/RD	Ringling signal		N/A

IEC 62040-1			
Clause	Requirement + Test	Result - Remark	Verdict
M.3.1.1/R D	Frequency (Hz)		—
M.3.1.2/R D	Voltage (V)		—
M.3.1.3/R D	Cadence; time (s), voltage (V)		—
M.3.1.4/R D	Single fault current (mA).....		—
M.3.2/RD	Tripping device and monitoring voltage		N/A
M.3.2.1/R D	Conditions for use of a tripping device or a monitoring voltage		—
M.3.2.2/R D	Tripping device		N/A
M.3.2.3/R D	Monitoring voltage (V)		N/A

A/RD	Annex A, Tests for resistance to heat and fire	P
A.1/RD	Flammability test for fire enclosures of movable equipment having a total mass exceeding 18 kg, and of stationary equipment (see 4.7.3.2/RD)	N/A
A.1.1/RD	Samples.....	—
	Wall thickness (mm)	—
A.1.2/RD	Conditioning of samples; temperature (°C).....	N/A
A.1.3/RD	Mounting of samples	N/A
A.1.4/RD	Test flame (see IEC 60695-11-3)	N/A
	Flame A, B, C or D.....	—
A.1.5/RD	Test procedure	N/A
A.1.6/RD	Compliance criteria	N/A
	Sample 1 burning time (s)	—
	Sample 2 burning time (s)	—
	Sample 3 burning time (s)	—
A.2/RD	Flammability test for fire enclosures of movable equipment having a total mass not exceeding 18 kg, and for material and components located inside fire enclosures (see 4.7.3.2/RD and 4.7.3.4/RD)	N/A
A.2.1/RD	Samples, material	—
	Wall thickness (mm)	—
A.2.2/RD	Conditioning of samples; temperature (°C).....	N/A
A.2.3/RD	Mounting of samples	N/A
A.2.4/RD	Test flame (see IEC 60695-11-4)	N/A

IEC 62040-1			
Clause	Requirement + Test	Result - Remark	Verdict
	Flame A, B or C		—
A.2.5/RD	Test procedure		N/A
A.2.6/RD	Compliance criteria		N/A
	Sample 1 burning time (s)		—
	Sample 2 burning time (s)		—
	Sample 3 burning time (s)		—
A.2.7/RD	Alternative test acc. to IEC 60695-11-5, cl. 5 and 9		N/A
	Sample 1 burning time (s)		—
	Sample 2 burning time (s)		—
	Sample 3 burning time (s)		—
A.3/RD	Hot flaming oil test (see 4.6.2/RD)		N/A
A.3.1/RD	Mounting of samples		N/A
A.3.2/RD	Test procedure		N/A
A.3.3/RD	Compliance criterion		N/A

B/RD	Annex B, Motor tests under abnormal conditions (see 4.7.2.2/RD and 5.3.2/RD)		P
B.1/RD	General requirements	Approved DC fan used. See appended table 4.5	N/A
	Position		—
	Manufacturer		—
	Type		—
	Rated values		—
B.2/RD	Test conditions		N/A
B.3/RD	Maximum temperatures		N/A
B.4/RD	Running overload test		N/A
B.5/RD	Locked-rotor overload test		N/A
	Test duration (days)		—
	Electric strength test: test voltage (V)		—
B.6/RD	Running overload test for d.c. motors in secondary circuits		N/A
B.6.1/RD	General		N/A
B.6.2/RD	Test procedure		N/A
B.6.3/RD	Alternative test procedure		N/A
B.6.4/RD	Electric strength test; test voltage (V)		N/A

IEC 62040-1			
Clause	Requirement + Test	Result - Remark	Verdict
B.7/RD	Locked-rotor overload test for d.c. motors in secondary circuits		N/A
B.7.1/RD	General		N/A
B.7.2/RD	Test procedure		N/A
B.7.3/RD	Alternative test procedure		N/A
B.7.4/RD	Electric strength test; test voltage (V)..... :		N/A
B.8/RD	Test for motors with capacitors		N/A
B.9/RD	Test for three-phase motors		N/A
B.10/RD	Test for series motors		N/A
	Operating voltage (V) :		—

C/RD	Annex C, Transformers (see 1.5.4/RD and 5.3.3/RD)		P
	Position	T1 on PS1203_MN1 board T1 on PS1203_TF3 board	—
	Manufacturer	(see appended table 4.5)	—
	Type	(see appended table 4.5)	—
	Rated values	(see appended table 4.5)	—
	Method of protection.....	Inherent impedance	—
C.1/RD	Overload test	(see appended table 8.3 and 5.3/RD)	P
C.2/RD	Insulation	(see appended table C.2/RD and Sub-clause 8.2)	P
	Protection from displacement of windings	Secured by tubing and insulation tape. See appended table C.2/RD	P

D/RD	Annex D, Measuring instruments for touch current tests (see 5.1.4/RD)		P
D.1/RD	Measuring instrument	Measuring instrument according to figure D.1 was used.	P
D.2/RD	Alternative measuring instrument		N/A

E/RD	Annex E, Temperature rise of a winding (see Annex E/RD)	N/A
-------------	--	------------

F/RD	Annex F, Measurements of clearances and creepage distance (see 2.10/RD and Annex G/RD)	N/A
-------------	---	------------

IEC 62040-1			
Clause	Requirement + Test	Result - Remark	Verdict

G/RD	Annex G, Alternative method for determining minimum clearances		N/A
G.1/RD	Clearances		N/A
G.1.1/RD	General		N/A
G.1.2/RD	Summary of the procedure for determining minimum clearances		N/A
G.2/RD	Determination of mains transient voltage (V)		N/A
G.2.1/RD	AC mains supply		N/A
G.2.2/RD	Earthed d.c. mains supplies		N/A
G.2.3/RD	Unearthed d.c. mains supplies		N/A
G.2.4/RD	Battery operation.....		N/A
G.3/RD	Determination of telecommunication network transient voltage (V)		N/A
G.4/RD	Determination of required withstand voltage (V)		N/A
G.4.1/RD	Mains transients and internal repetitive peaks		N/A
G.4.2/RD	Transients from telecommunication networks		N/A
G.4.3/RD	Combination of transients		N/A
G.4.4/RD	Transients from cable distribution systems		N/A
G.5/RD	Measurement of transient voltages (V)		N/A
	a) Transients from a mains supply		N/A
	For an a.c. mains supply		N/A
	For a d.c. mains supply		N/A
	b) Transients from a telecommunication network		N/A
G.6/RD	Determination of minimum clearances.....		N/A

H	Annex H, Guidance on protection against ingress of water and foreign objects (see IEC 60529)		N/A
----------	---	--	------------

I	Annex I, Backfeed protection test		P
I.1	General		P
I.2	Test for pluggable UPS	Safety relay provided. Even in case of a single fault the protection circuit acts within 50 ms and causes unit to shut down. See appended table 8.3 for details.	P

IEC 62040-1			
Clause	Requirement + Test	Result - Remark	Verdict
I.3	Test for permanently connected UPS		N/A
I.4	Load-induced change of reference potential		N/A
I.5	Solid-state backfeed protection (see clause 7.1-7.5 of IEC 62040-2 and clause 7.1-7.2 of IEC 62040-3)		N/A

J/RD	Annex J, Table of electrochemical potentials (see 2.6.5.6/RD)		P
	Metal(s) used	Copper and steel.	—

K/RD	Annex K, Thermal controls (see 1.5.3/RD and 5.3.8/RD)		N/A
K.1/RD	Making and breaking capacity		N/A
K.2 /RD	Thermostat reliability; operating voltage (V)		N/A
K.3/RD	Thermostat endurance test; operating voltage (V)		N/A
K.4/RD	Temperature limiter endurance; operating voltage (V)		N/A
K.5/RD	Thermal cut-out reliability		N/A
K.6/RD	Stability of operation		N/A

L	Annex L, Reference loads		P
L.1	General		P
L.2	Reference resistive load		P
L.3	Reference inductive-resistive load		—
L.4	Reference capacitive-resistive loads		P
L.5	Reference non-linear load		P
L.5.1	General		P
L.5.2	Test method		P
L.5.3	Connection of the non-linear reference load		—

M	Annex M, Ventilation of battery compartments		P
----------	---	--	----------

IEC 62040-1			
Clause	Requirement + Test	Result - Remark	Verdict
M.1	General	Sufficient openings and a suitable arrangement of components (circuit breaker) are provided in such a way that a local concentration of hydrogen and oxygen is not possible. No requirement regarding the separation of operational arcing parts from battery vents/valves.	P
M.2	Normal conditions	See appended table M	P
M.3	Blocked conditions	Block test applied, see appended table 8.3	P
M.4	Overcharge conditions	See appended table M.	P

N	Annex N, Minimum and maximum cross-sections of copper conductors suitable for connection (see 6.3)		N/A
----------	---	--	------------

U/RD	Annex U, Insulated winding wires for use without interleaved insulation (see 2.10.5.4/RD)		N/A
			<input type="checkbox"/>

V/RD	Annex V, AC POWER DISTRIBUTION SYSTEMS (see 1.6.1/RD)		P
V.1/RD	Introduction		P
V.2/RD	TN power distribution systems		P
V.3/RD	TT power distribution systems		N/A
V.4/RD	IT power distribution systems		N/A

IEC 62040-1			
Clause	Requirement + Test	Result - Remark	Verdict

4.6, 1.6.2/RD		TABLE: Electrical Data (in normal conditions)					P
fuse #	I rated (A)	U (V)	P (W)	I (A)	I fuse (A)	condition/status	
Input breaker	--	342/50Hz	210526	354.42	354.42	Condition A: Load 380Vac/50Hz 200KW	
Input breaker	--	342/60Hz	210526	354.42	354.42		
Input breaker	384	380/50Hz	210526	318.98	318.98		
Input breaker	384	380/60Hz	210526	318.98	318.98		
Input breaker	384	400/50Hz	210084	304.47	304.47		
Input breaker	384	400/60Hz	210084	304.47	304.47		
Input breaker	384	415/50Hz	211640	293.94	293.94		
Input breaker	384	415/60Hz	211640	293.94	293.94		
Input breaker	--	440/50Hz	212766	275.96	275.96		
Input breaker	--	440/60Hz	212766	275.96	275.96		
Input breaker	--	342/50Hz	210305	354.05	354.05	Condition B: Load 400Vac/50Hz 200KW	
Input breaker	--	342/60Hz	210305	354.05	354.05		
Input breaker	384	380/50Hz	210305	318.64	318.64		
Input breaker	384	380/60Hz	210305	318.64	318.64		
Input breaker	384	400/50Hz	209864	304.15	304.15		
Input breaker	384	400/60Hz	209864	304.15	304.15		
Input breaker	384	415/50Hz	211416	293.63	293.63		
Input breaker	384	415/60Hz	211416	293.63	293.63		
Input	--	440/50Hz	212540	275.67	275.67		

IEC 62040-1						
Clause	Requirement + Test				Result - Remark	Verdict
breaker						Condition C: Load 415Vac/50Hz 200KW
Input breaker	--	440/60Hz	212540	275.67	275.67	
Input breaker	--	342/50Hz	210305	354.05	354.05	
Input breaker	--	342/60Hz	210305	354.05	354.05	
Input breaker	384	380/50Hz	210305	318.64	318.64	
Input breaker	384	380/60Hz	210305	318.64	318.64	
Input breaker	384	400/50Hz	209864	304.15	304.15	
Input breaker	384	400/60Hz	209864	304.15	304.15	
Input breaker	384	415/50Hz	211416	293.63	293.63	
Input breaker	384	415/60Hz	211416	293.63	293.63	
Input breaker	--	440/50Hz	212540	275.67	275.67	
Input breaker	--	440/60Hz	212540	275.67	275.67	
Supplementary information:						

5.1.1 2.1.1.5/RD	TABLE: Max. V, A, VA Test				N/A
Voltage (rated) (V)	Current (rated) (A)	Voltage (max.) (V)	Current (max.) (A)	VA (max.) (VA)	
--	--	--	--	--	
Supplementary information:					

5.1.1 2.1.1.5/RD	TABLE: Stored Energy		N/A
Capacitance C (µF)	Voltage U (V)	Energy E (J)	
--	--	--	
Supplementary information:			

IEC 62040-1					
Clause	Requirement + Test			Result - Remark	Verdict
5.1.1 2.1.1.7/ RD	TABLE: discharge of capacitors in the primary circuit				P
Condition	τ calculated (s)	τ measured (s)	$t_{u \rightarrow 0V}$ (s)	Comments	
Input L1-N	--	0.48	1.92	Tested at online mode with batteries	
Input L2-N	--	0.44	1.76		
Input L3-N	--	0.44	1.76		
Input L1-PE	--	0.46	1.84		
Input L2-PE	--	0.44	1.76		
Input L3-PE	--	0.42	1.68		
Input N-PE	--	0	0		
BAT+-PE		0.21	0.84	Battery mode	
BAT--PE		0.23	0.92		
Input L1-N	--	0.25	1	Tested at bypass mode without batteries	
Input L2-N	--	0.23	0.92		
Input L3-N	--	0.25	1		
Input L1-PE	--	0.48	1.92		
Input L2-PE	--	0.5	2		
Input L3-PE	--	0.5	2		
Input N-PE	--	0	0		
Supplementary information:					

5.2.1 2.2/RD	TABLE: Evaluation Of Voltage Limiting Components In SELV Circuits				P
Component (measured between)	Max. voltage (V) (normal operation)		Voltage Limiting Components		
	V peak	V d.c.			
PS1203_MN1 board					
T1 After pin 9 to D57	11.8	11.4	--		
PS1203_TF3 board					
T1 After D15 to Pin9	14.7	14	--		
Fault test performed on voltage limiting components	Voltage measured (V) in SELV circuits (V peak or V d.c.)				
--	--				

IEC 62040-1			
Clause	Requirement + Test	Result - Remark	Verdict
Supplementary information: s-c=Short circuit			

5.2.3 2.4.2/RD	Table: Limited current circuit measurement					N/A
Location	Voltage (mV)	Current (mA)	Freq. (kHz)	Limit (mAp)	Comments	
--	--	--	--	--	--	
Supplementary information:						

5.3.1 and 2.6.3.4/RD	Table: Resistance of earthing measurement			P
Location	Resistance measured (mΩ)		Comments	
--	--		--	
Supplementary information: Earthing continuity is achieved by sufficient conductor size. See relevant clauses.				

5.5.4	Table: Short-time withstand current test			N/A
Rated max. output current	Announced withstand current	Test current	Comments	
--	--	--	--	
Supplementary information: Specified Icc not exceed 10kA, no test necessary.				

5.2.5 2.5/RD	TABLE: Limited Power Sources					N/A
Circuit output tested:						
Note: Measured Uoc (V) with all load circuits disconnected:						
Components	Test condition (Single fault)	Uoc (V)	Isc (A)		VA	
			Meas.	Limit	Meas.	Limit
--	--	--	--	--	--	--
Supplementary information: Sc=Short circuit, Oc=Open circuit						

5.7 2.10.2/RD	Table: Working Voltage Measurement			P
------------------	------------------------------------	--	--	---

IEC 62040-1			
Clause	Requirement + Test	Result - Remark	Verdict
Location	RMS voltage (V)	Peak voltage (V)	Comments
PS1203_MN1 board			
T1 Pin2--6	92.7	138	
T1 Pin2--7	93.2	146	
T1 Pin2--9	93.0	140	
T1 Pin2--10	92.7	138	
T1 Pin4--6	93.2	150	
T1 Pin4--7	92.7	142	
T1 Pin4--9	92.7	138	
T1 Pin4--10	93.4	150	
Supplementary information:			

5.7, 2.10.3/RD	TABLE: Clearance And Creepage Distance Measurements					P
clearance cl and creepage distance dcr at/of:	Up (V)	U r.m.s. (V)	Required cl (mm)	cl (mm)	required dcr (mm)	dcr (mm)
Metal enclosure to bare pin of battery terminal	<420	275V	2.0	5.5	2.8	5.5
Primary pin to earthed metal plate on Input EMI PCB	<420	275V	2.0	5.0	2.8	>5.0
Primary pin to earthed metal enclosure on Output EMI PCB	<420	275V	2.0	8.0	2.8	>8.0
Supplementary information: *FI=Functional insulation, BI=Basic insulation, RI=Reinforced insulation. Unless otherwise specified, the worst conditions of Cl. & Cr. In above mentioned locations have been considered and listed.						

5.7, 2.10.5.2/ RD	TABLE: Distance Through Insulation Measurements				N/A
Distance through insulation di at/of:	U r.m.s. (V)	Test voltage (V)	Required di (mm)	di (mm)	
--	--	--	--	--	
Supplementary information: *see information in table 4.5 for details.					

7.4, 4.5.5/RD	TABLE: Ball Pressure Test of Thermoplastics	N/A
------------------	---	-----

IEC 62040-1			
Clause	Requirement + Test	Result - Remark	Verdict
Allowed impression diameter (mm)			—
Object/ Part No./ Material	Manufacturer/ trademark	Test temperature (°C)	Impression diameter (mm)
--	--	--	--
Supplementary information: Phenolic material bobbin used in Transformer and Line Choke without test.			

7.4.2 4.6/RD	TABLE: Openings		P
Location	Size (mm)	Comments	
Top	None	No openings	
Bottom	None	No openings	
Side	None	No openings	
Front	3.5mm(W)* 14.9mm(L), rectangle type	No hazardous voltage or energy parts located vertically, or within a volume V bounded by a 5° vertical projection up to size of opening L.	
Rear	3.5mm(W)* 14.9mm(L), rectangle type	No hazardous voltage or energy parts located vertically, or within a volume V bounded by a 5° vertical projection up to size of opening L.	
Supplementary information:			

7.5 4.7/RD	TABLE: Resistance to fire					P
Part	Manufacturer of material	Type of material	Thickness (mm)	Flammability class	Evidence	
Enclosure	SABIC JAPAN L L C	C2950	2.5 mm	5VA	UL	
PCB	Interchangeable	Interchangeable	2.0 mm	V-0	UL	
Supplementary information: see appended table 4.5						

7.7, 4.5/RD	TABLE: Heating Test					P
	Test voltage (V)	323V/60Hz	457V/50Hz	Battery Mode	--	—
	Ambient (°C)	40	40	40	--	—
Thermocouple Locations		Max. temperature measured, (°C)				Max. temperature limit, (°C)

IEC 62040-1					
Clause	Requirement + Test	Result - Remark			Verdict
UPS internal					
Enclosure (plastic panel)	45.1	54.6	43.2	--	95
Enclosure (metal)	49.2	56.3	50.3	--	70
AC terminal	61.2	57.9	60.4	--	90
AC Air-Switch	53.3	58.9	51.8	--	Ref.
DC Fan	59.8	59.4	59.1	--	Ref.
Battery terminal	47.3	55.2	58.5	--	90
Copper	78.6	69.4	76.4	--	90
BYP—SCR	106.2	116.6	47.5	--	135
board					
Y Capacitor on MN1 board	79.9	60.6	63.4	--	85
Transformer (T1) coil on MN1 board	66.5	67.4	65.8	--	110
Transformer (T1) core on TF3 board	84.3	65.9	49.2	--	110
Opto coupler on MN1 board	59.4	54.4	55.2	--	100
PCB near transformer T1 on MN1board	53.9	53.4	53.3	--	130
PCB near transformer T1 on MN1board	51.8	50.6	51.2	--	130
Ambient	40.0	40.0	40.0	--	--
Supplementary information: 1. The temperatures were measured under the worst case normal mode defined in 1.2.2.1/RD and as described in sub-clause 4.6 at voltages as described above. 2. With a specified ambient temperature of 40°C.					

7.7, 4.5/RD	TABLE: Heating test, resistance method					N/A
	Test voltage (V)					—
	Ambient, t ₁ (°C).....					—
	Ambient, t ₂ (°C).....					—
Temperature rise of winding	R ₁ (Ω)	R ₂ (Ω)	ΔT (K)	Max. dT (K)	Insulation class	
--	--	--	--	--	--	
Supplementary information:						

8 5.1/RD	TABLE: touch current measurement	P
Supplementary information:		

IEC 62040-1			
Clause	Requirement + Test	Result - Remark	Verdict
Measured between:	Measured (mA)	Limit (mA)	Comments/conditions
Metal enclosure to terminal A(three phase balance)	1.9 / 1.2	3.5	Switch 'e' opened, TN system
Metal enclosure to terminal A under R-phase imbalance	0.9 / 1.4	3.5	Switch 'e' opened, TN system
Metal enclosure to terminal A under S-phase imbalance	0.9 / 1.27	3.5	Switch 'e' opened, TN system
Metal enclosure to terminal A under T-phase imbalance	0.87 / 1.55	3.5	Switch 'e' opened, TN system
Parallel port to terminal A	0.005 / 0.005	0.25	Switch 'e' closed, TN system
RS-232 terminal to terminal A	0.005 / 0.005	0.25	Switch 'e' closed, TN system
LCD to terminal A	0.005 / 0.005	0.25	Switch 'e' closed, TN system
Supplementary information:			

8.2 5.2/RD	TABLE: Dielectric Strength	P
Test voltage applied between:	Test potential applied (V)	Breakdown / flashover (Yes/No)
Primary to Secondary interface (interface of Port for MCU interface board and CSB board)	DC 4242	No
Input/output R/S/T to earth	DC 2121	No
Battery +/- to earth	DC 2121	No
Primary to secondary in safety isolation transformers (T1 on PS1203_MN1 board)	DC 4242	No
Primary to secondary in safety isolation transformers (T1 of PS1203_TF3 board)	DC 4242	No
Supplementary information:		

8.3 5.3/RD	TABLE: Fault condition tests					P
	Ambient temperature (°C) :				See below	—
	Power source for EUT: Manufacturer, model/type, output rating :					—
Component No.	Fault	Supply voltage (V)	Test time	Fuse #	Fuse current (A)	Observation

IEC 62040-1						
Clause	Requirement + Test				Result - Remark	Verdict
Output	s-c	415	1s	Input breaker	-	UPS output shut down immediately, the charger operate normally, no damaged. Charge voltage: 576V, Output voltage: 0V.
Output	s-c	battery	1s	Input breaker	-	UPS output shut down immediately, no damaged. Charge voltage: 0V, Output voltage: 0V.
Output	o-l	415	15min	Input breaker	-	UPS output shut down at condition of 5min at 100% load + 5min at 117% load + 2s at 133% load.
Output	o-l	Battery mode	15min	Input breaker	--	UPS output shut down at condition of 5min at 100% load + 5min at 117% load + 2s at 133% load.
BYP-SCR	s-c	415	1s	Input breaker	--	Bypass supply. No damage. No hazards. Warning signal alarm sounds. LCD display Warning information (Bypass failed, Inverter supply prohibited).
Ventilation openings	Block-ed	415	30min.	Input breaker	--	UPS shut down at temperature protection, after the temperature is below 60°C, UPS open up. Repeat the cycle continuously.
Ventilation openings	Block-ed	Battery mode	30min	Input breaker	--	UPS shut down at temperature protection, after the temperature is below 60°C, UPS open up. Repeat the cycle continuously.
Fan	Locked	415	30mins	Input breaker	--	UPS shut down at temperature protection, after the temperature is below 60°C, UPS open up. Repeat the cycle continuously.
Fan	Locked	Battery mode	30mins	Input breaker	--	UPS shut down at temperature protection, after the temperature is below 60°C, UPS open up. Repeat the cycle continuously.
<p>Supplementary information: s-c: short circuit, o-c: open circuit, o-l: over load</p> <ol style="list-style-type: none"> 1. SELV outputs did not exceed 42.4 V_{peak} or 60 V_{dc} and did not exceed the limit of 71 V_{peak} or 120 V_{dc} within 0.2 second after abnormal conditions were applied. 2. The Electric Strength Tests were successfully conducted after the completion of fault. 3. Transformer winding and core temperature limit is 165°C (175-10) 4. Test with model RM200/25C output 380V, 304A, 200KW 						

IEC 62040-1			
Clause	Requirement + Test	Result - Remark	Verdict

C.2/RD		TABLE: transformers						P
Loc.	Tested insulation	Working voltage peak / V (2.10.2)	Working voltage rms / V (2.10.2)	Required electric strength (5.2)	Required clearance / mm (2.10.3)	Required creepage distance / mm (2.10.4)	Required distance thr. insul. (2.10.5)	
T1 on PS1203_MN1 board	Pri. to sec.: Reinforced insulatio	420	240	3000VAC	4.0	5.0	- Triple insulated wire	
Loc.	Tested insulation			Test voltage/ V	Measured clearance / mm	Measured creepage dist./ mm	Measured distance thr. insul. / mm; number of layers	
T1 on PS1203_MN1 board	Pri. to sec.: Reinforced insulation			3000VAC	>4.0	>5.0	- Triple insulated wire	
T1 on PS1203_MN1 board	Pri. to sec.: Reinforced insulation			3000VAC	>4.0	>5.0	- Triple insulated wire	
Supplementary information: *) 2 layers or 3 layers or Annex U All transformer sources are identical except manufacturer.								

C.2/RD		TABLE: transformers						P
--------	--	---------------------	--	--	--	--	--	---

IEC 62040-1			
Clause	Requirement + Test	Result - Remark	Verdict

Transformer: T1 transformer on PS1203_MN1 board
Construction / winding diagram

I. 安装尺寸及外形图(CONFIGURATION & DIMENSIONS) (使用ER40型16Pin骨架)

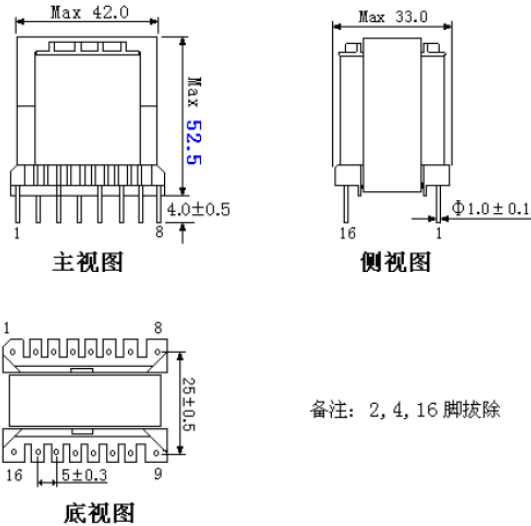

3. 内部结构图(WINDING CONSTRUCTION)

(用图示表明骨架中各绕组、绝缘层、隔离带的位置分布)

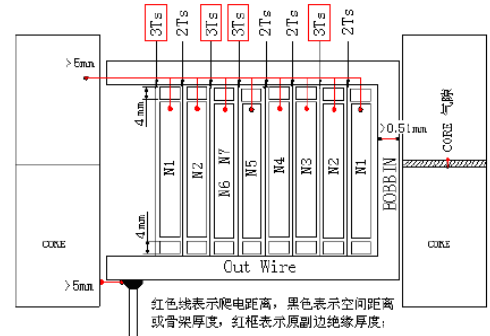

4. 线圈联线图 (SCHEMATIC)

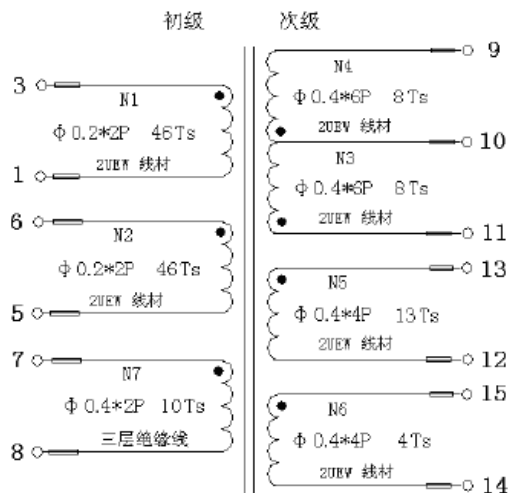

备注:
绕线前, 调整骨架插入接嘴的方向, 以最少绕组的交叉排线为准。

Transformer: T1 transformer on PS1203_TF3 board
Construction / winding diagram

IEC 62040-1			
Clause	Requirement + Test	Result - Remark	Verdict

1. 安装尺寸及外形图 (CONFIGURATION & DIMENSIONS) (E116骨架)

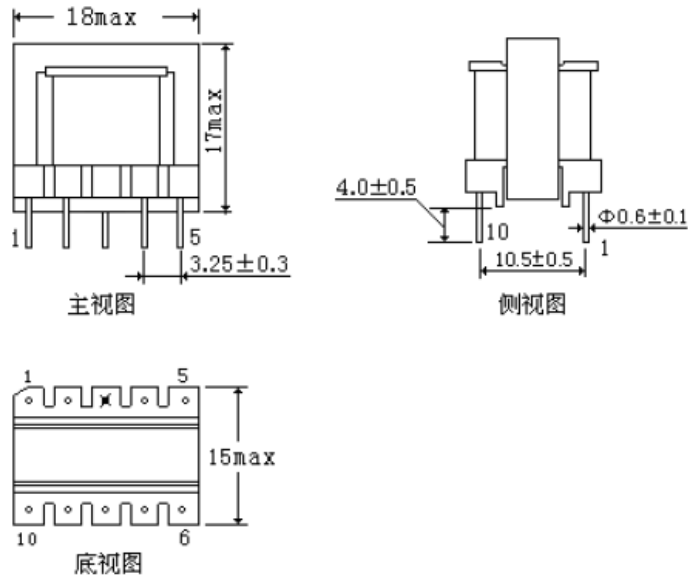

3. 内部结构图 (WINDING CONSTRUCTION)

(用图式表明骨架中各绕组、绝缘层、隔离带的位置分布)

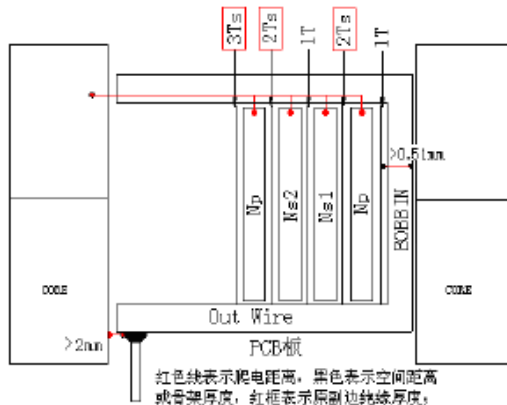

4. 线圈联线图 (SCHEMATIC)

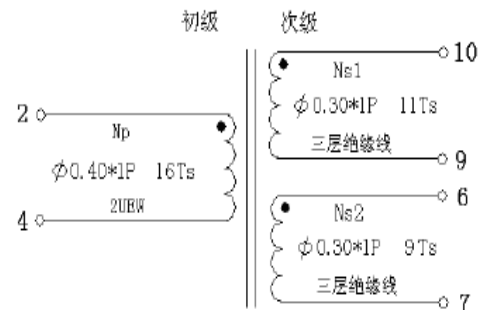

M	Ventilation of battery compartments	N/A
	The required dimension for the ventilation openings will be calculated with the following formula:	

IEC 62040-1			
Clause	Requirement + Test	Result - Remark	Verdict
	$A \geq Q/360 [m^2]$ $\text{with } Q = 0.054 * n * I * C$ <p>where:</p> <p>Q : airflow in m³/h n : number of battery cells I : constant factor (0,2A/100Ah for valve regulated lead acid batteries) C : is the battery nominal capacity in Ah at the 10h discharge rate</p>		
	With the specific data for the UPS the following dimension for the ventilation openings is required:		
	n : C : $A \geq (0.054 * n * 0.2 A/100 Ah * C)/360$ $A \geq$		
	Verdict		
	The size of ventilation openings in battery cabinet exceeds the required airflow by far (as well as the UPS).		

4.5	TABLE: Critical components information					P
Object / part No.	Manufacturer/ trademark	Type / model	Technical data	Standard	Mark(s) of conformity ¹	
Whole unit						
Front panel	SABIC JAPAN L L C	C2950	5VA, 85°C, Min. thickness 2.5mm	UL 746D	UL E207780	
DC fan	NMB	09225VA24 QAL01	DC24V, 0.49A, 11.8W	UL 507	UL: E89936	
Insulation sheet	ITW ELECTRONICS COMPONENTS/ PRODUCTS (SHANGHAI) CO LTD	Formex GK-10	minimum thickness 0.4 mm, V-0, 115°C	UL 94 UL 746C	UL: E256266	
Alternative	FORMEX, DIV OF ILLINOIS TOOL WORKS INC, FORMERLY	Formex GK-10	minimum thickness 0.4 mm, V-0, 115°C	UL 94 UL 746C	UL: E121855	
SCR	SEMIKRON	SKKT273/1 2E	273A ,1200V	IEC/EN 62040-1	Test with appliance	
Wire	Interchangeable	Interchange able	--	UL758	UL: E314168	
ON ASY01_PS1312_DR7						

IEC 62040-1					
Clause	Requirement + Test		Result - Remark		Verdict
Y1 capacitor(C3,C4)	Interchangeable	CD16-E2GA472M YGS	400VAC/ 4700pF	IEC 60384-14	VDE: 124321
Transformer (T1,T2,T3)	SIDNA	UMS33P1T 2	Class B	IEC/EN 62040-1	Test with appliance
Optocouplers (U2)	SHARP	PC817X3NI P0F	Isolation Voltage 4243Vac	IEC/EN 60950-1 IEC/EN60747 - 5-2 UL 1577	UL: E64380
NMOS(Q8,Q9 ,Q10)	PHILIPS	PSMN130-200D	20A/200V	IEC/EN 62040-1	Test with appliance
PCB	Interchangeable	Interchangeable	Minimum V-0, 130°C	UL 796	UL
ON ASY01_PS1203_MN2					
Y2 capacitor (C143)	TDK	CS11-E2GA222M YNS	250VAC/ 2200pF	IEC 60384-14	UL:E37861 VDE:124321
Transformer (T1)	Boulder	UMX33MN 1T1	CLASS B	IEC/EN 62040-1	Test with appliance
FUSE (F1)	Hollyland	50CF F630mAH 250V	630mAH 250V	IEC/EN 62040-1	UL: E156471
PCB	Interchangeable	Interchangeable	Minimum V-0, 130°C	UL 796	UL
PS1203_PW3					
DC capacitor (C7,C8)	Jianghai	CD293-220UF	450V, 820uF, 85°C	IEC/EN 62040-1	Test with appliance
X2 capacitor (C1,C2)	Faratronic	C42P2474K 9SC000	0.47µF,275VAC	IEC 60384-14 UL 60384-14	UL: E186600 VDE: 40000358
Y2 capacitor (C11,C12,C61)	TDK	CS11-E2GA222M YNS	250VAC/ 2200pF	IEC 60384-14 UL 60384-14	UL:E37861 CE:124321
Y1 capacitor (C3,C4,C5,C6 ,C59,C60)	TDK	CD16-E2GA472M YGS	4.7Nf,400Vac	IEC 60384-14 UL 60384-14	UL:E37861 CE:124321
Transformer (T1)	SIDNA	UMS33P1T 2	Class B	IEC/EN 62040-1	Test with appliance

IEC 62040-1					
Clause	Requirement + Test	Result - Remark			Verdict
Transformer (T3)	Boulder	UMXPS3T1	Class B	IEC/EN 62040-1	Test with appliance
PCB	Interchangeable	Interchangeable	Minimum V-0, 130°C	UL 796	UL
ON ASY01_PS1203_TF2					
PCB	Interchangeable	Interchangeable	Minimum V-0, 130°C	UL 796	UL
ON ASY01_PS1203_TF3					
Optocouplers (U6,U7,U8,U9,U10,U11,U12,U13,U19)	NEC	PS2561L-1-V-F3-A-L	Isolation Voltage 4243Vac	IEC/EN 60950-1 IEC/EN60747 - 5-2 UL 1577	UL:E72422
Optocouplers (U20)	AVAGO	HCMR201	Isolation Voltage 4243Vac	IEC/EN 60950-1 IEC/EN60747 - 5-2 UL 1577	UL:E55361
Relay (RLY1,RLY2,RLY3,RLY4)	Song Chuan Precision Co., Ltd.	892-1CC-C-24VDC	24V, 3A	UL 60947-1 EN 61810-1	UL:E88991 VDE: 40006318
PCB	Interchangeable	Interchangeable	Minimum V-0, 130°C	UL 796	UL
ON ASY01_PS1507_EM2					
Y2 capacitor (C8,C9,C10)	TDK	CS11-E2GA222M YNS	250VAC, 2200pF, 85°C	UL 60384-14 IEC 60384-14	UL:E37861 CE:124321
X2 capacitor (C11,C12,C13,C14,C15,C16)	Xiamen Faratronic Co. Ltd.	C42P2565-BSC000	250VAC, 5.6 μ F, 100°C	UL 60384-14 IEC 60384-14	UL: E186600 VDE: 40000358
PCB	Interchangeable	Interchangeable	Minimum V-0, 130°C	UL 796	UL
ON ASY01_PS1507_EM3					
FUSE (F1,F2,F3)	COOPER BUSSMANN LLC	BK-GBH-V030A6FR	30A, 500VAC	UL 248-1	UL:E56412
PCB	Interchangeable	Interchangeable	Minimum V-0, 130°C	UL 796	UL
ON SNT_DL_3320_FR_01					

IEC 62040-1					
Clause	Requirement + Test	Result - Remark	Verdict		
X2 capacitor (C1,C2,C3,C4)	Faratronic	C43Q1224 MB0C450	250VAC, 0.22 μ F, 100°C	UL 60384-14 IEC 60384-14	UL:E18660 0 CE:400003 58
Y2 capacitor (C5,C6,C7,C8,C9,C10,C11,C12,C13,C14)	TDK	CS11-E2GA222M YNS	250VAC, 2200pF, 85°C	UL 60384-14 IEC 60384-14	UL: E37861 VDE: 124321
PCB	Interchangeable	Interchangeable	Minimum V-0, 130°C	UL 796	UL
ON ASY01_PS1502_CV4					
PCB	Interchangeable	Interchangeable	Minimum V-0, 130°C	UL 796	UL
ON ASY01_PS1509_TF1					
PCB	Interchangeable	Interchangeable	Minimum V-0, 130°C	UL 796	UL
ON ASY01_PS1601_DR9					
NMOS(Q1)	FAIRCHILD	FQA9N90	8.6A/900V	IEC/EN 62040-1	Test with appliance
FUSE (F9,F10)	HOLLY	50CF F8AH 250V	250V;8A	UL 248-1	UL: E156471
Thyristor (Q2)	VISHAY	40TPS12	40A 1200V	--	--
ON ASY01_PS1504_KY1					
PCB	Interchangeable	Interchangeable	Minimum V-0, 130°C	UL 796	UL
ON ASY01_PS1508_TF2					
PCB	Interchangeable	Interchangeable	Minimum V-0, 130°C	UL 796	UL
ON ASY01_PS1503_EM4					
FUSE (F1,F2,F3,F4,F5,F6,F7)	TAMURA	T3F	2A/250V	IEC/EN 62040-1	Test with appliance
PCB	Interchangeable	Interchangeable	Minimum V-0, 130°C	UL 796	UL
ON ASY01_PS1601_TF1					
PCB	Interchangeable	Interchangeable	Minimum V-0, 130°C	UL 796	UL

IEC 62040-1			
Clause	Requirement + Test	Result - Remark	Verdict
Supplementary information: 1) Provided evidence ensures the agreed level of compliance. See OD-2039.			

IEC 62040-1_1A - ATTACHMENT 1			
Clause	Requirement + Test	Result - Remark	Verdict

ATTACHMENT TO TEST REPORT IEC 62040-1 EUROPEAN GROUP DIFFERENCES AND NATIONAL DIFFERENCES Uninterruptible power systems (UPS) – Part 1: General and safety requirements for UPS			
Differences according to.....:		EN 62040-1:2008	
Attachment Form No.:		EU_GD_IEC62040_1A	
Attachment Originator.....:		Nemko	
Master Attachment.....:		Date (2010-06)	
Copyright © 2010 IEC System for Conformity Testing and Certification of Electrical Equipment (IECEE), Geneva, Switzerland. All rights reserved.			

EN 62040-1:2008 – CENELEC COMMON MODIFICATIONS

EN 62040-1, GROUP DIFFERENCES (CENELEC common modifications EN)			
Clause	Requirement + Test	Result - Remark	Verdict
Contents	Add the following annexes: Annex ZA (normative) Annex ZB (normative)	Normative references to international publications with their corresponding European publications Special national conditions	N/A

IEC 62040-1_1A - ATTACHMENT 1			
Clause	Requirement + Test	Result - Remark	Verdict

ZA	NORMATIVE REFERENCES TO INTERNATIONAL PUBLICATIONS WITH THEIR CORRESPONDING EUROPEAN PUBLICATIONS			—		
	<p>The following referenced documents are indispensable for the application of this document. For dated references, only the edition cited applies. For undated references, the latest edition of the referenced document (including any amendments) applies.</p> <p>Note: When an international publication has been modified by common modifications, indicated by (mod), the relevant EN/HD Applies.</p>					
	<u>Publication</u>	<u>Year</u>	<u>Title</u>		<u>EN/HD</u>	<u>Year</u>
	IEC 60364-4-42	- ¹⁾	Electrical installations of buildings - Part 4-42: Protection for safety - Protection against thermal effects		-	-
	IEC 60417	Data-base	Graphical symbols for use on equipment		-	-
	IEC 60529	- ¹⁾	Degrees of protection provided by enclosures (IP Code)		EN 60529 + corr. May	1991 ²⁾ 1993
	IEC 60664	Series	Insulation coordination for equipment within low-voltage systems		EN 60664	Series
	IEC/TR 60755	- ¹⁾	General requirements for residual current operated protective devices		-	-
	IEC 60950-1 (mod)	2005	Information technology equipment - Safety - Part 1: General requirements		EN 60950-1	2006
	IEC 61000-2-2	- ¹⁾	Electromagnetic compatibility (EMC) - Part 2-2: Environment - Compatibility levels for low-frequency conducted disturbances and signalling in public low-voltage power supply systems		EN 61000-2-2	2002 ²⁾
	IEC 61008-1 (mod)	- ¹⁾	Residual current operated circuit-breakers without integral overcurrent protection for household and similar uses (RCCB's) - Part 1: General rules		EN 61008-1 + A11	2004 ²⁾ 2007
	IEC 61009-1 (mod)	- ¹⁾	Residual current operated circuit-breakers with integral overcurrent protection for household and similar uses (RCBO's) - Part 1: General rules		EN 61009-1 + corr. July + A11	2004 ²⁾ 2006 2008
	IEC 62040-2	2005	Uninterruptible power systems (UPS) - Part 2: Electromagnetic compatibility (EMC) requirements		EN 62040-2 + corr. November	2006 2006
IEC 62040-3 (mod)	1999	Uninterruptible power systems (UPS) - Part 3: Method of specifying the performance and test requirements	EN 62040-3	2001		
			¹⁾ Undated reference.			
			²⁾ Valid edition at date of issue.			

IEC 62040-1_1A - ATTACHMENT 1			
Clause	Requirement + Test	Result - Remark	Verdict

<p align="center">ZB ANNEX (normative) SPECIAL NATIONAL CONDITIONS (EN)</p> <p>The FI, NO and SE - SNCs originate from IEC 60950-1 2nd Edition, which is the reference document (RD) for IEC 62040-1. The national requirements are included in IEC 62040-1 through the following statement in the scope of the standard: <i>“National requirements additional to those in IEC 60950-1 apply and are found as notes under relevant clauses of the RD.”</i></p> <p>The national requirements have not been specifically listed in the EN 62040-1:2008. If demanded, CLC/TC 22X will be requested to take proper measures to complete EN 62040-1 with Annexes ZB containing the SNCs as presented below.</p> <p>EN 62040-1:2008 supersedes EN 62040-1-1:2003. As a reference, see also SNCs for Finland, Norway and Sweden as included in the earlier EN 62040-1-1:2003</p>			
Clause	Requirement + Test	Result - Remark	Verdict
4.7.3	<p>In Finland, Norway and Sweden, when safety relies upon connection to the safety earth (see 5.3), a pluggable equipment type A UPS shall have a marking on the equipment, stating that the UPS must be connected to an earthed mains socket-outlet.</p> <p>The marking text in the applicable countries shall be as follows:</p> <p>In Finland: "Laitte on liitettävä suojakoskettimilla varustettuun pistorasiaan"</p> <p>In Norway: "Apparatet må tilkoples jordet stikkontakt"</p> <p>In Sweden: "Apparaten skall anslutas till jordat uttag"</p>		N/A
4.7.11	<p>In Norway, because of a widely used IT power system, equipment shall be designed or modified for connection to such a system and shall be marked by a label with the following wording in Norwegian:</p> <p>"Apparatet er egnet for tilkopling til et IT forsyningsnett"</p>		P
9	<p>In Finland, Norway and Sweden requirements of 6.1.2.1 and 6.1.2.2 in Annex ZB of EN 60950-1:2001 apply.</p>		N/A

ATTACHMENT Photos



Figure 1: External view

ATTACHMENT Photos



Figure 2: External view

ATTACHMENT Photos



Figure 3: Rear view

ATTACHMENT Photos



Figure 4: Internal view

ATTACHMENT Photos



Figure 5: Internal view



Figure 6: PCB view

ATTACHMENT Photos



Figure 7: PCB trace view

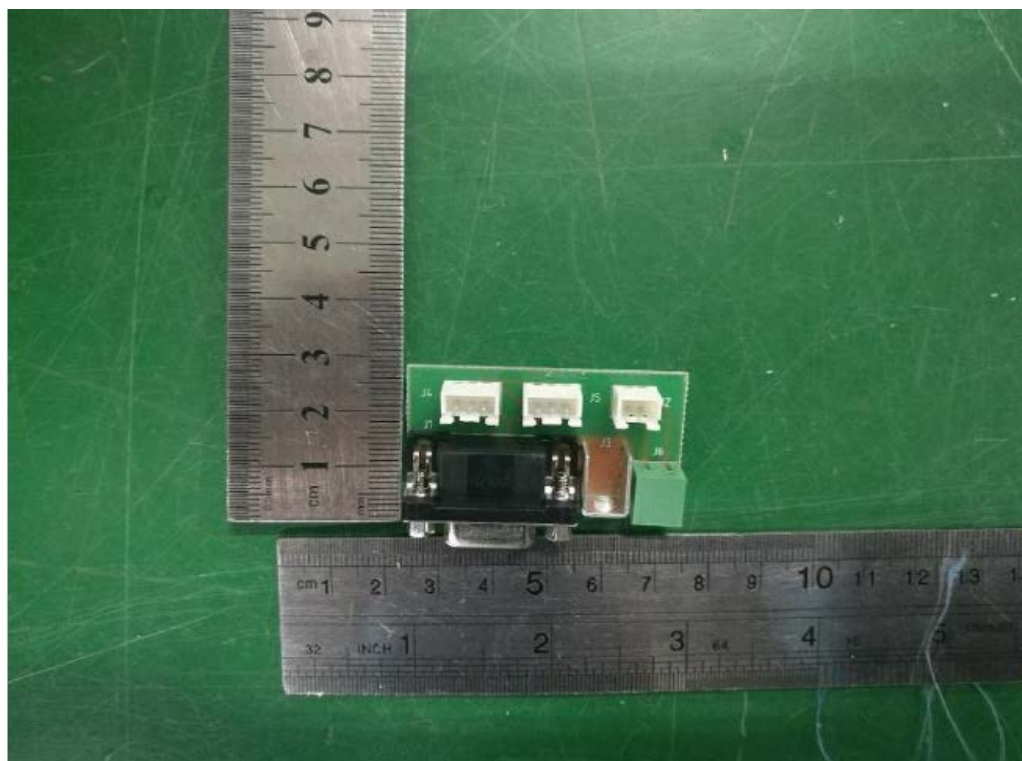

Figure 8: PCB component view

ATTACHMENT Photos

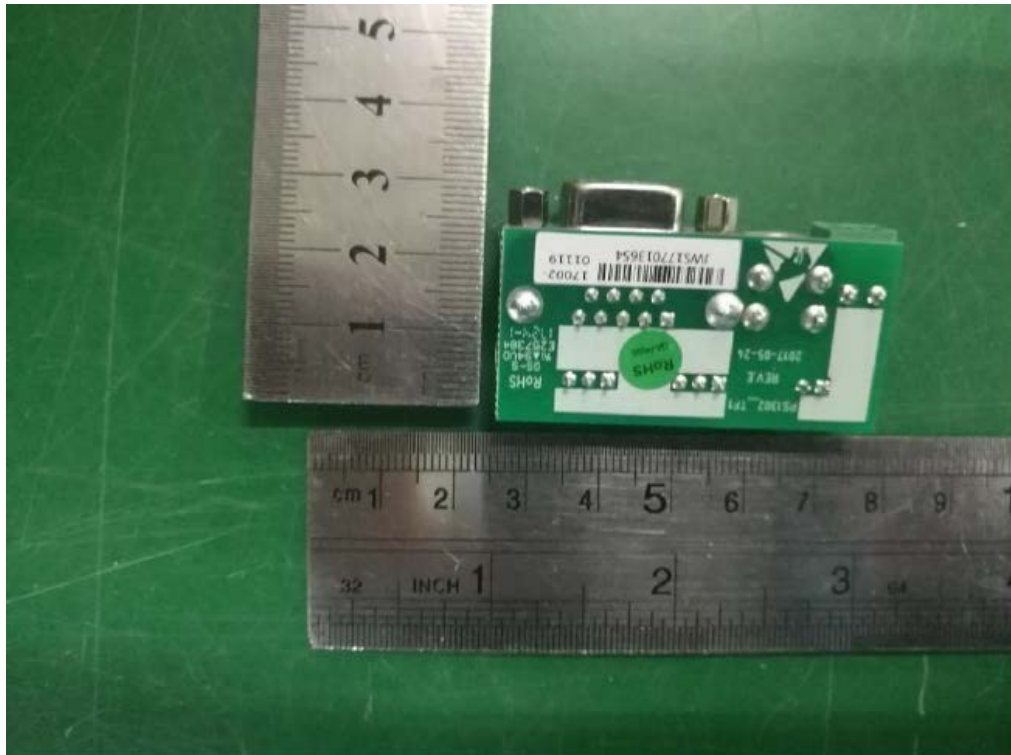

Figure 9: PCB trace view



Figure 10: PCB component view

ATTACHMENT Photos



Figure 11: PCB trace view

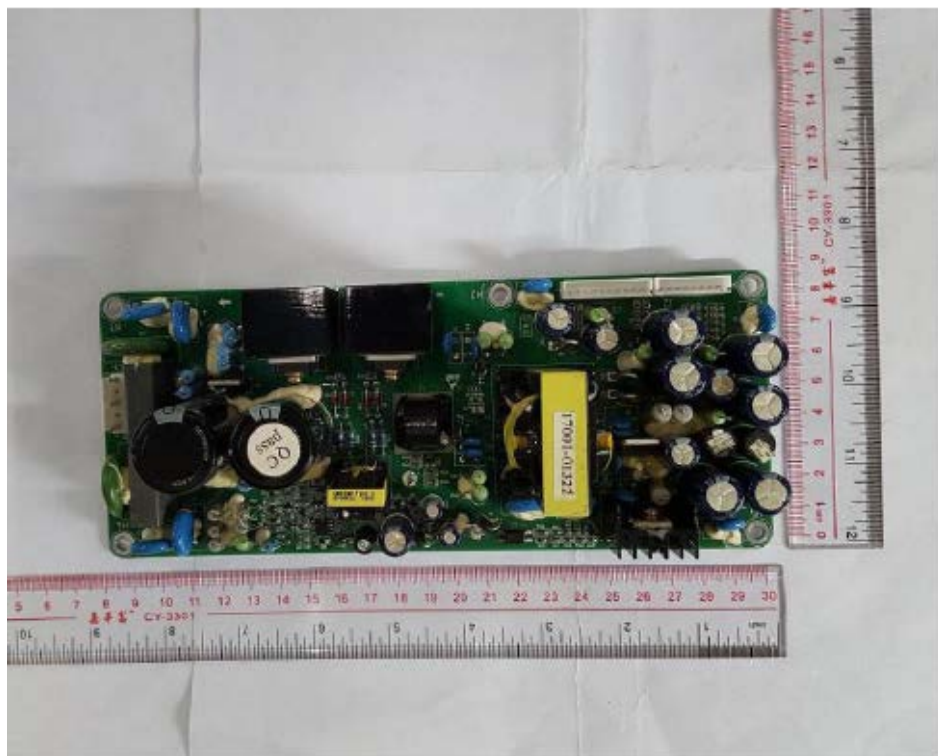

Figure 12: PCB component view

ATTACHMENT Photos

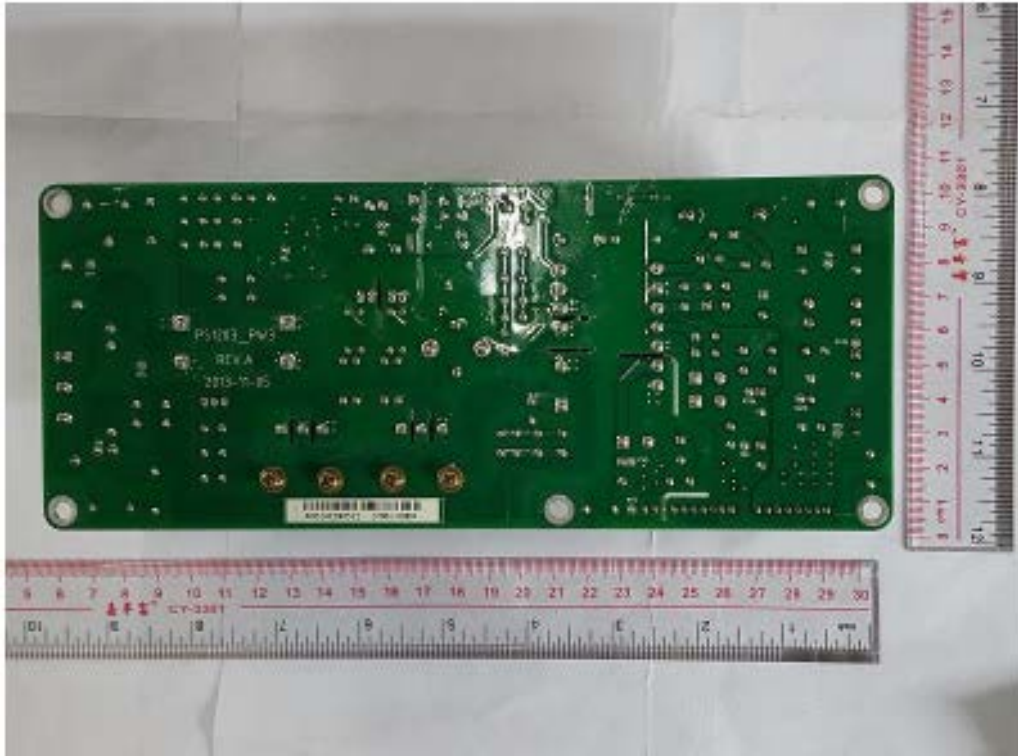

Figure 13: PCB trace view

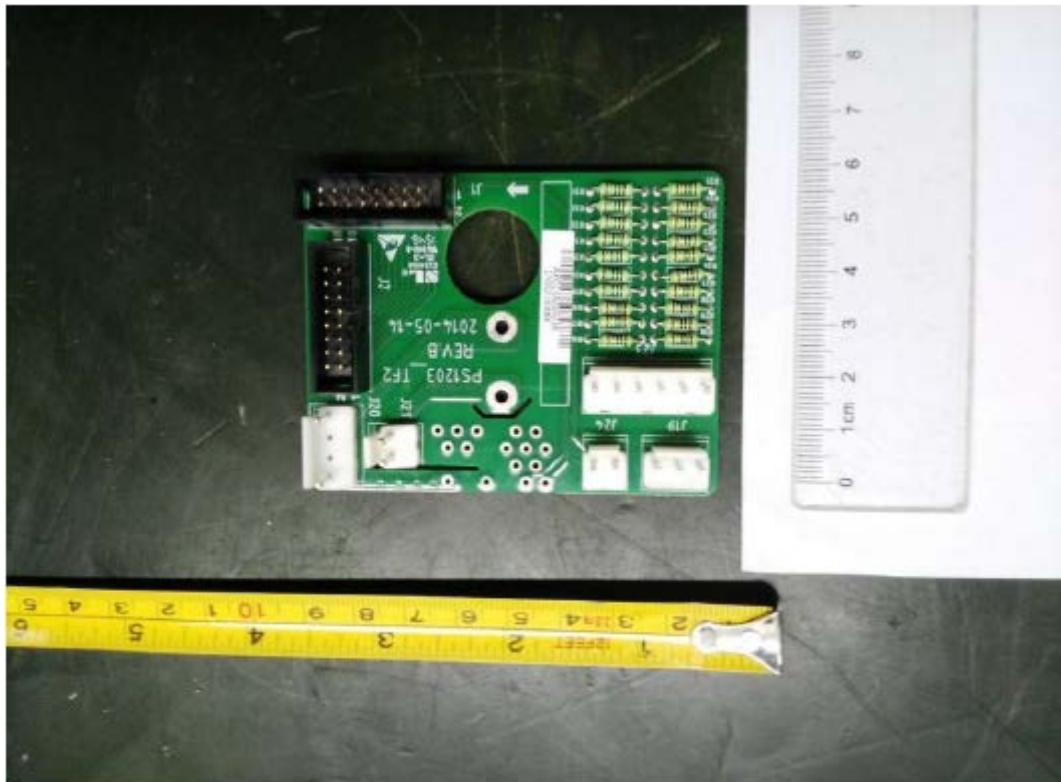

Figure 14: PCB component view

ATTACHMENT Photos

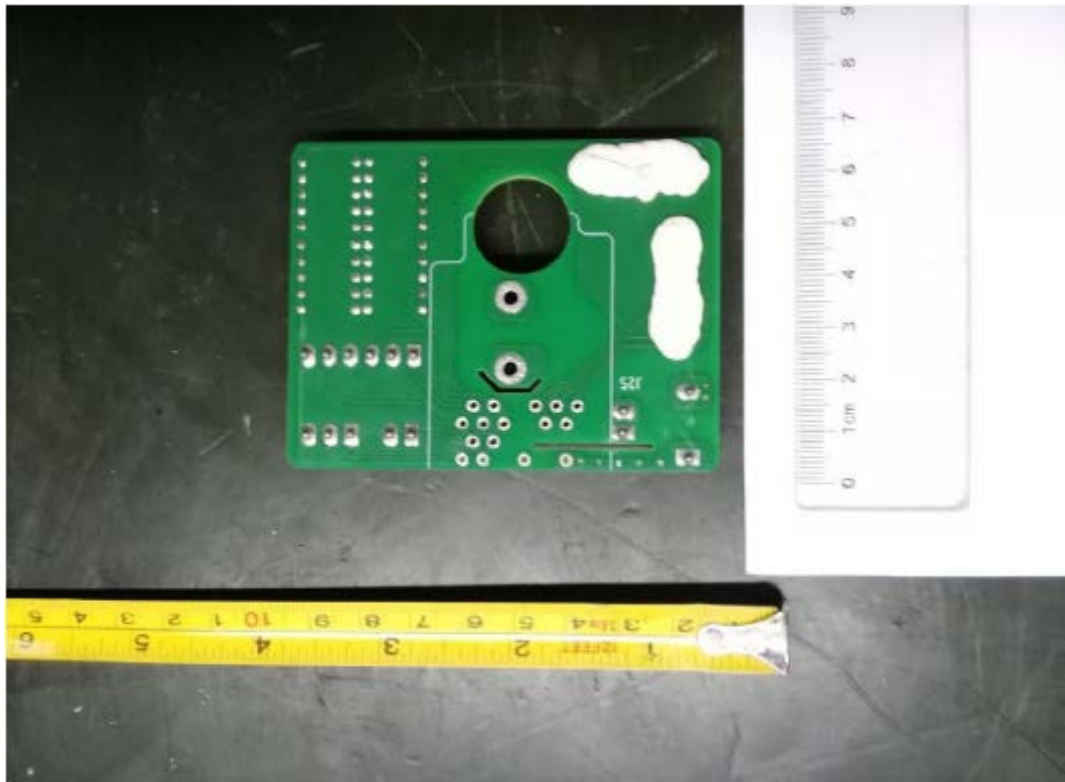

Figure 15: PCB trace view



Figure 16: PCB component view

ATTACHMENT Photos

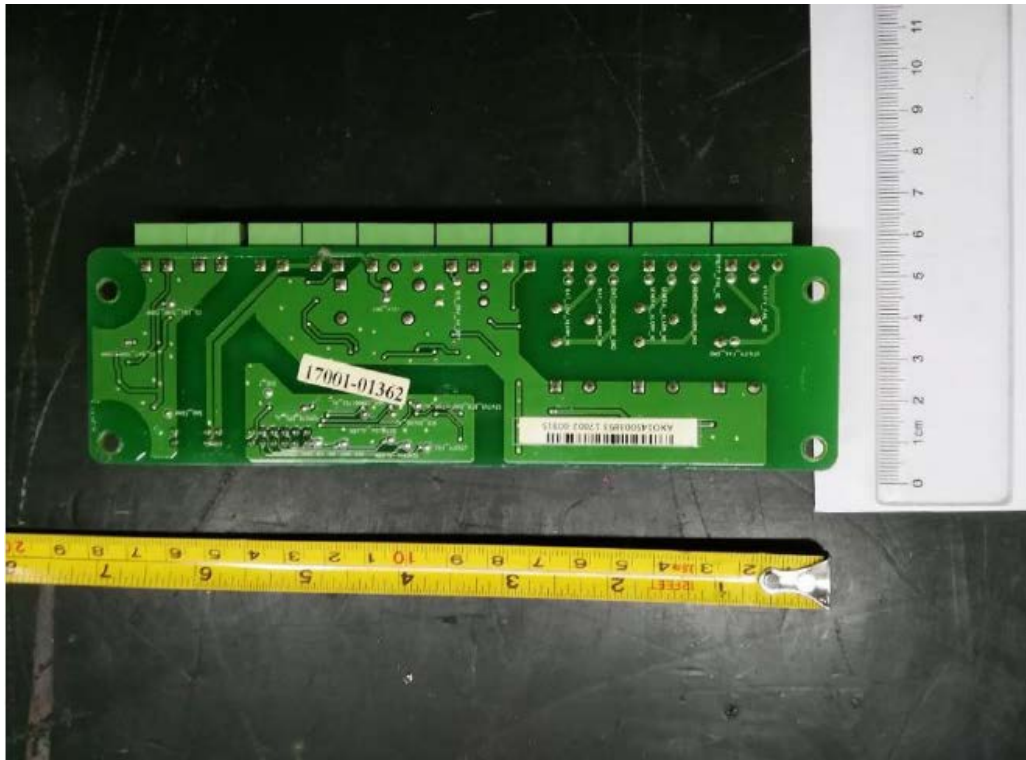
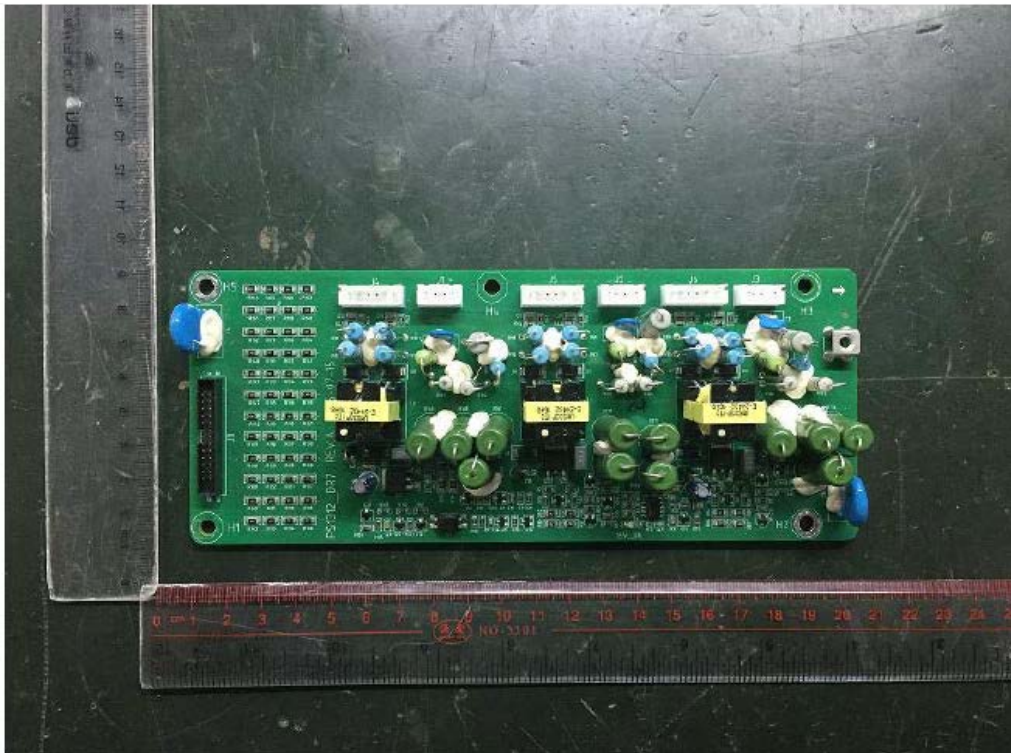

Figure 17: PCB trace view



ATTACHMENT Photos

Figure 20: PCB component view

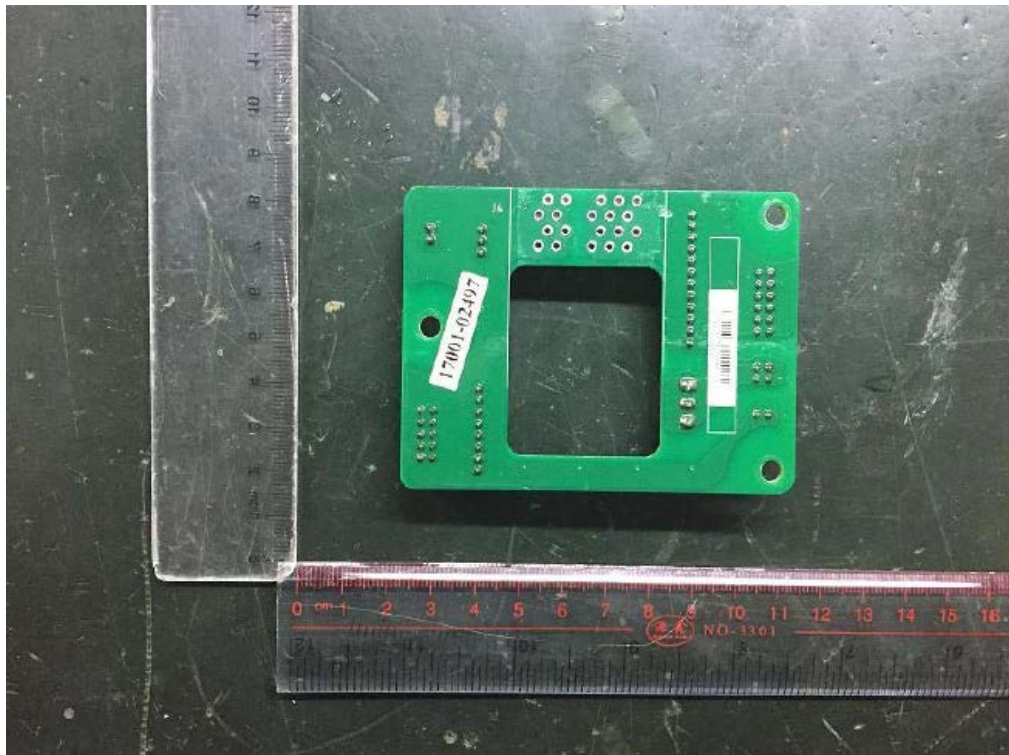

Figure 21: PCB trace view



ATTACHMENT Photos

Figure 22: PCB component view

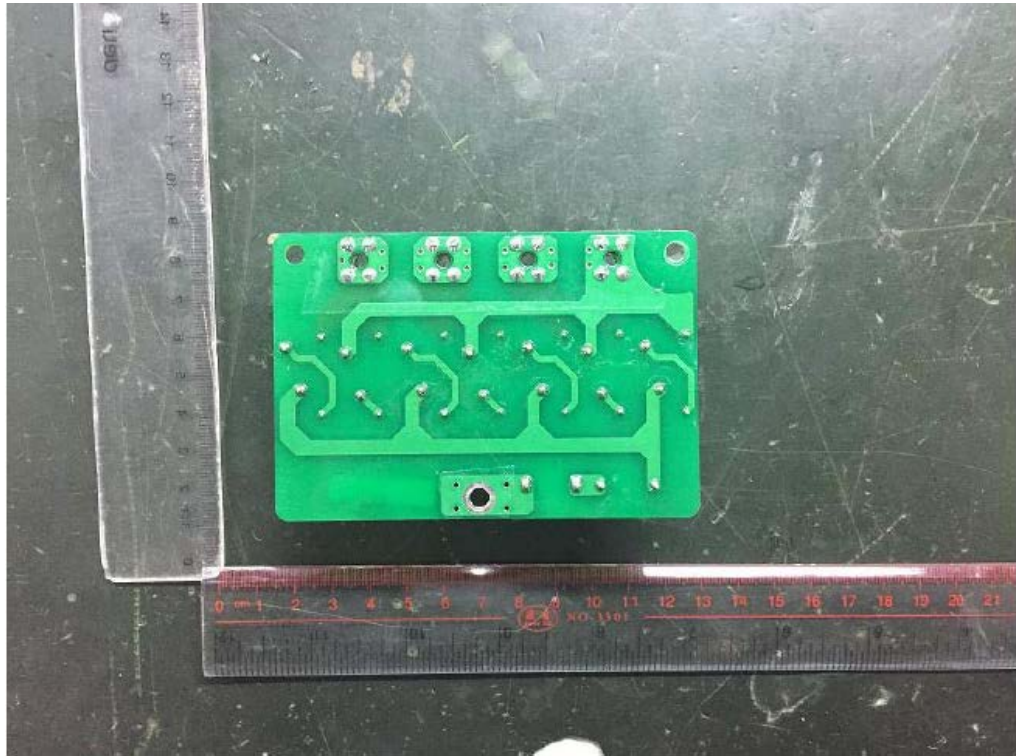
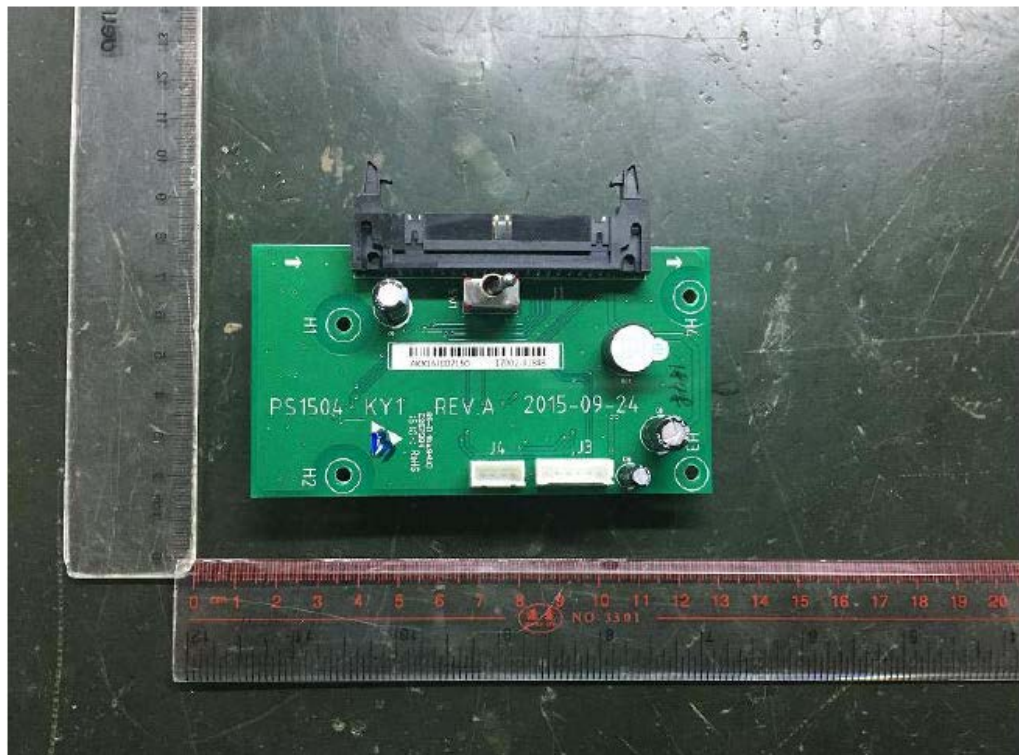

Figure 23: PCB trace view



ATTACHMENT Photos

Figure 24: PCB component view

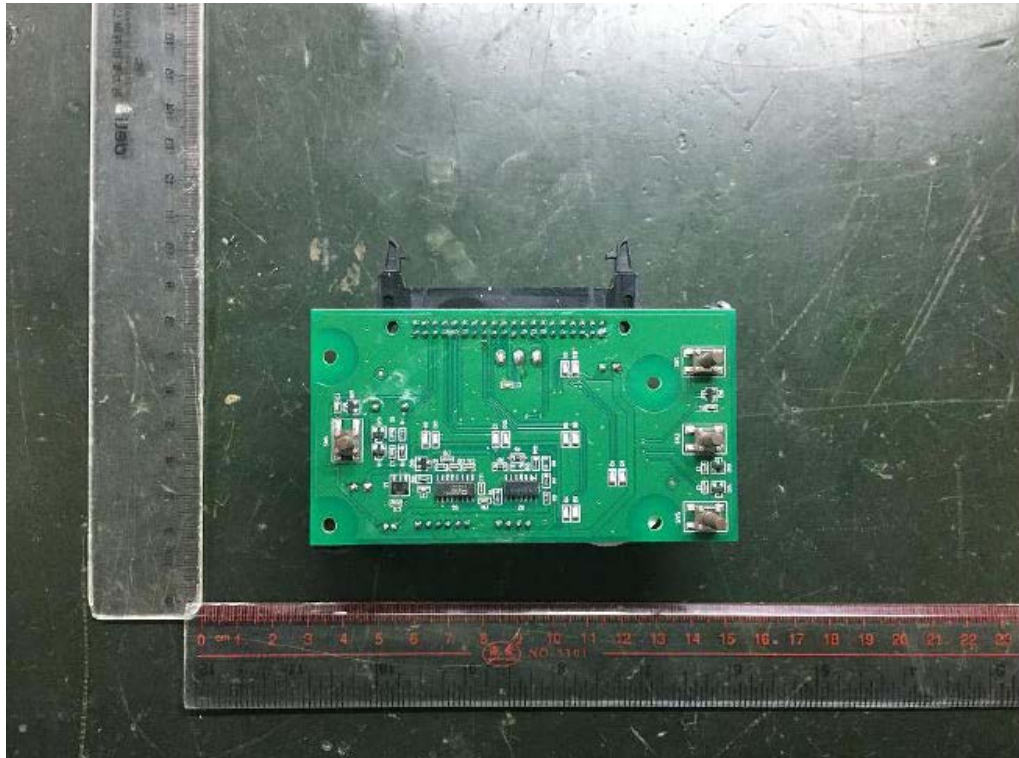
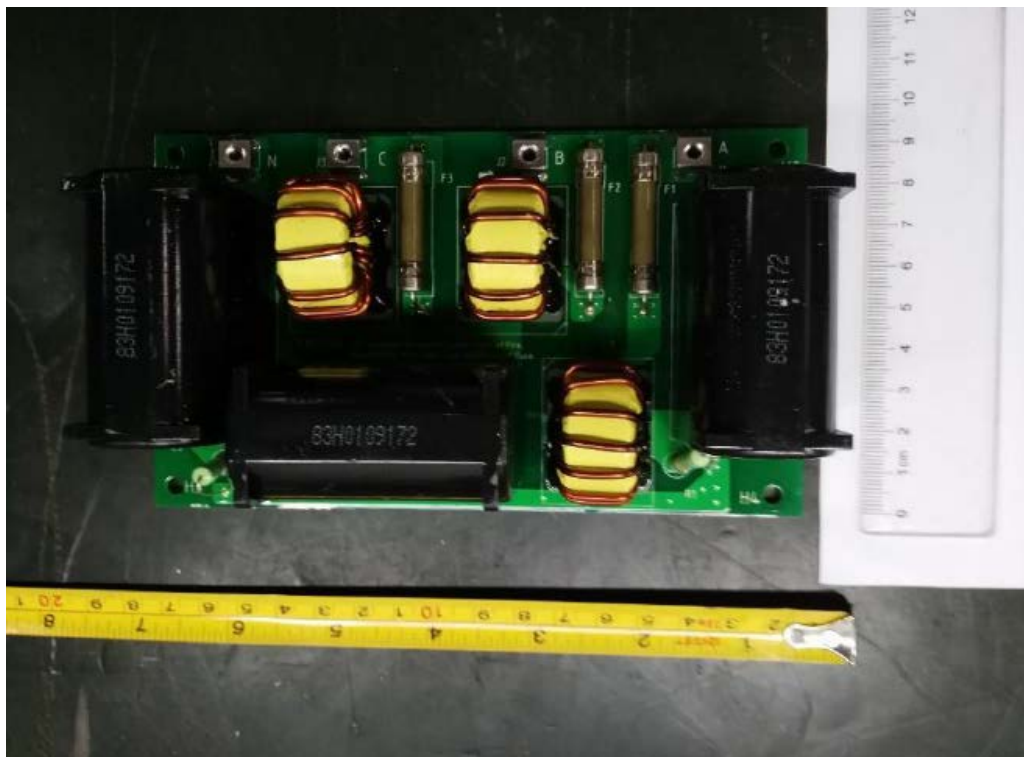

Figure 25: PCB trace view



ATTACHMENT Photos

Figure 26: PCB component view

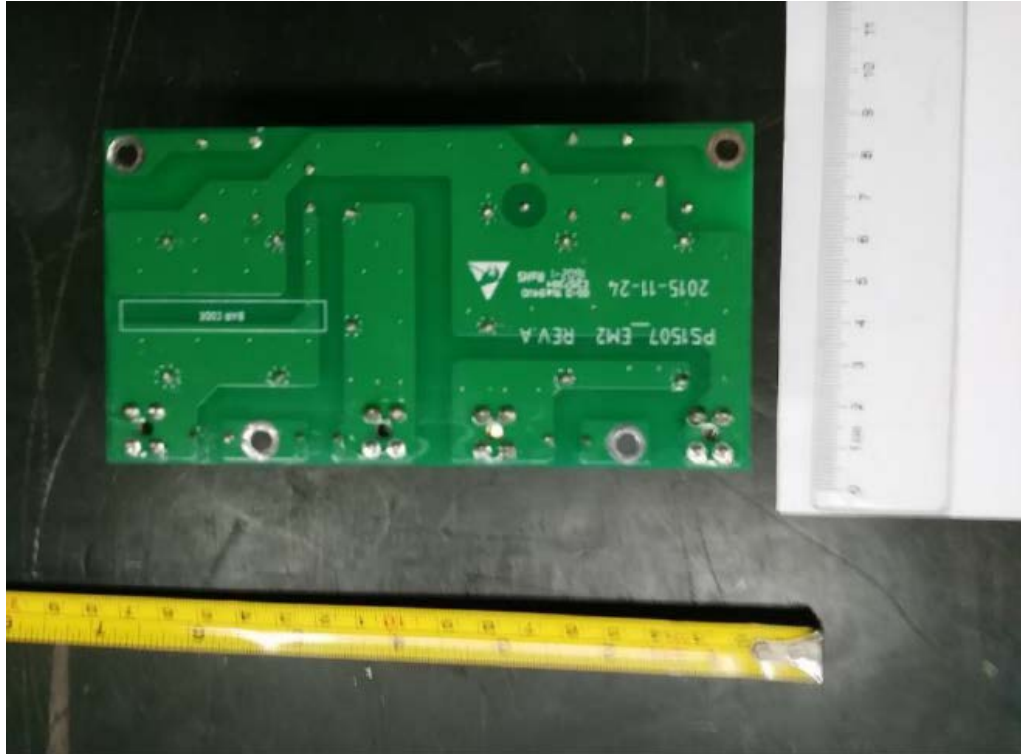
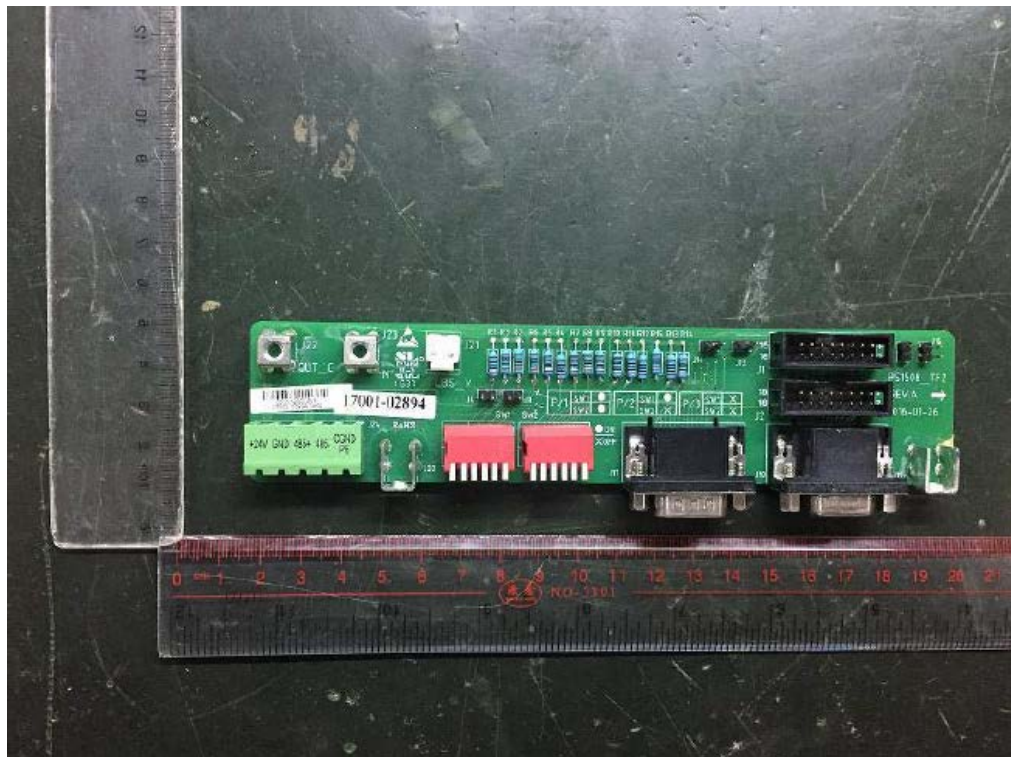

Figure 27: PCB trace view



ATTACHMENT Photos

Figure 28: PCB component view

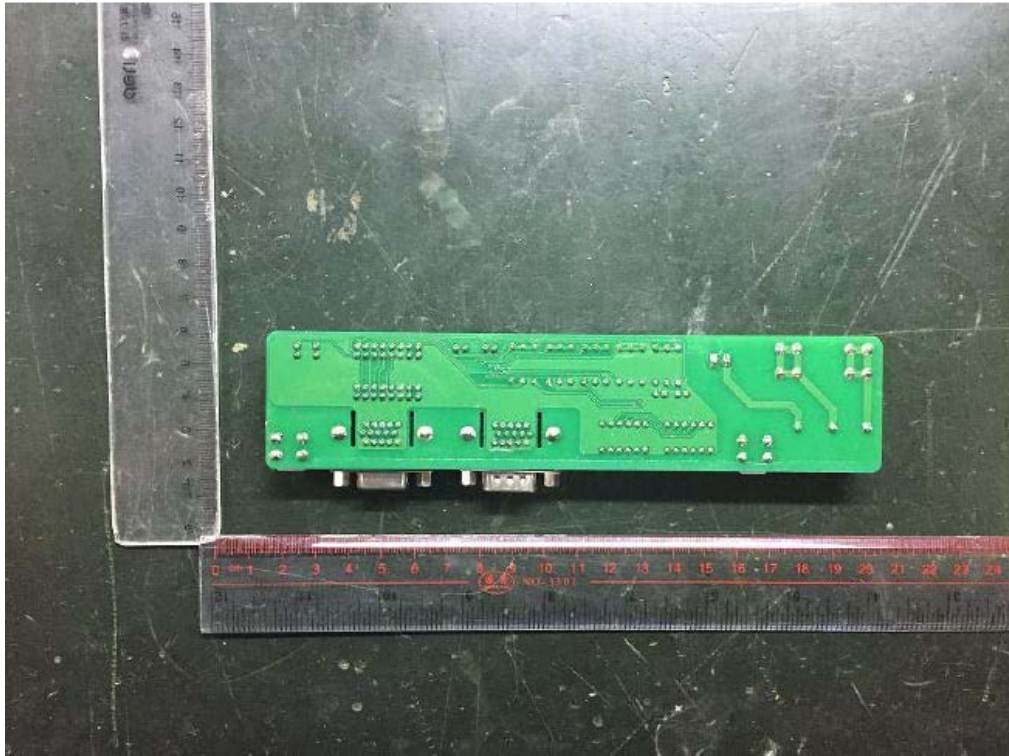

Figure 29: PCB trace view

ATTACHMENT Photos



Figure 30: PCB component view

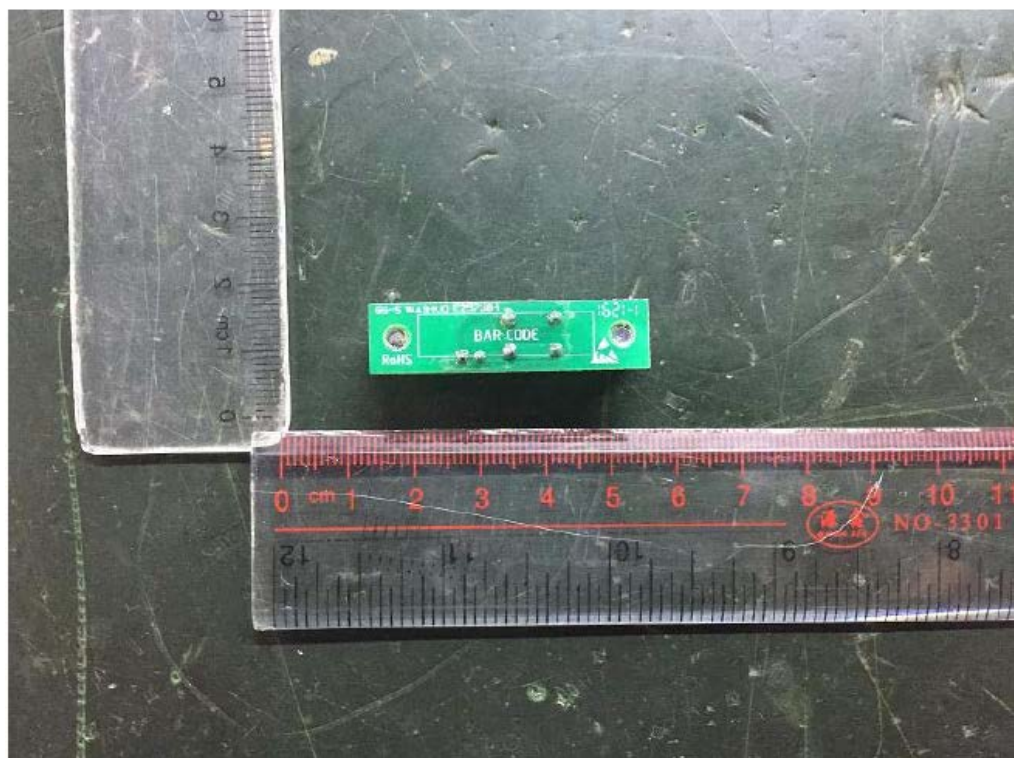

Figure 31: PCB trace view

ATTACHMENT Photos

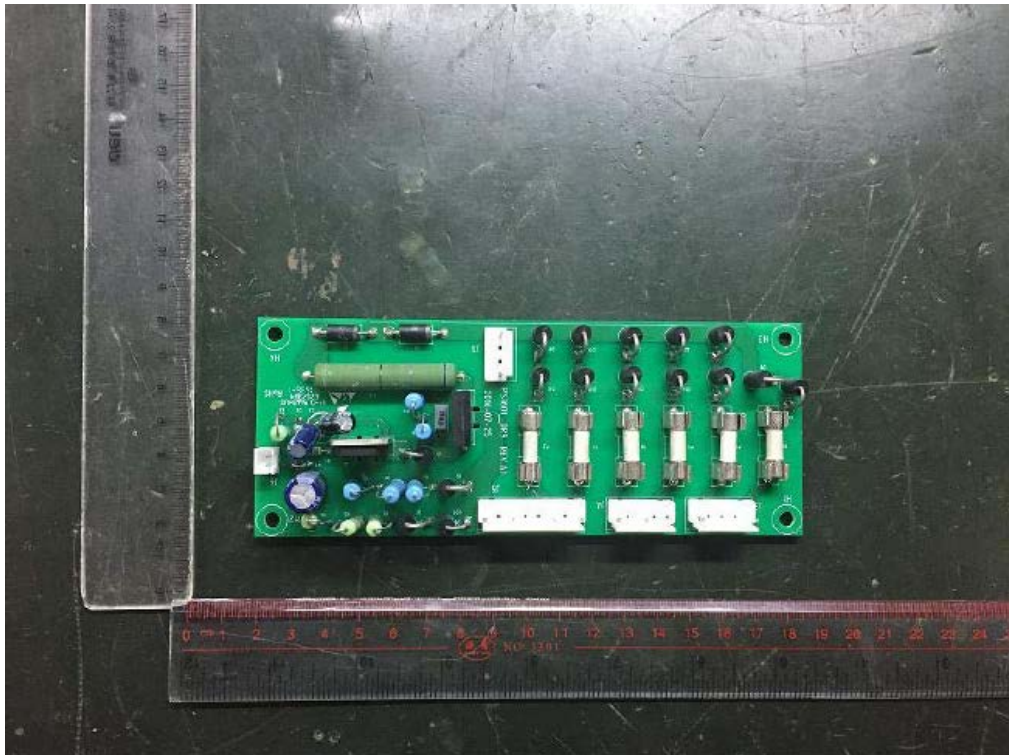

Figure 32: PCB component view

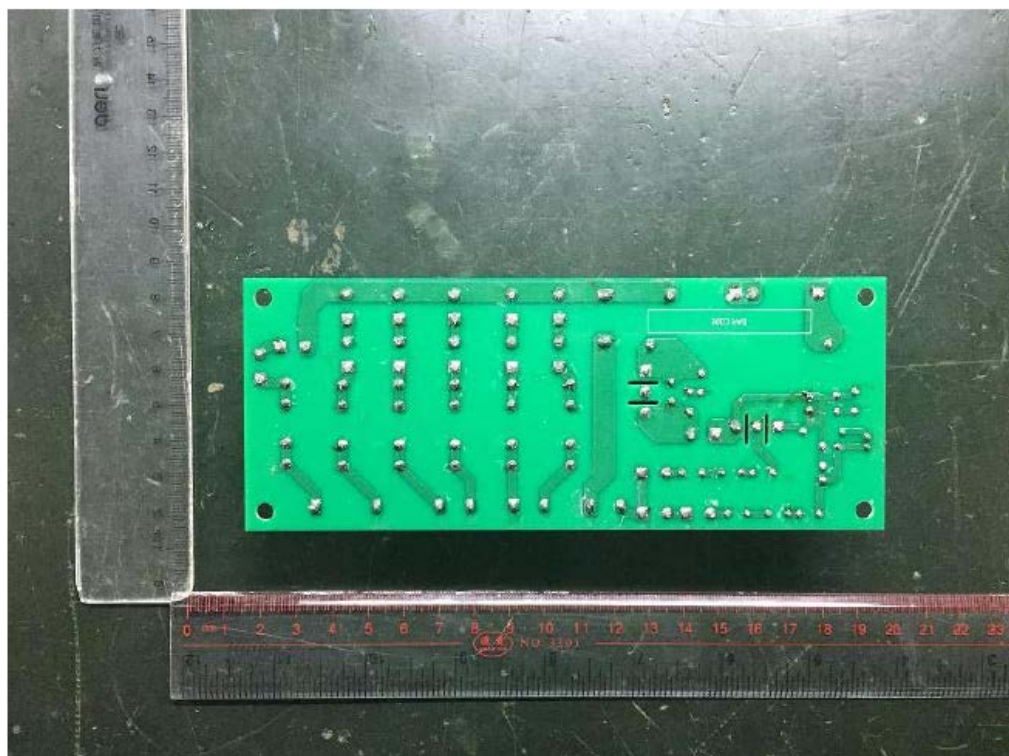

Figure 33: PCB trace view

ATTACHMENT Photos

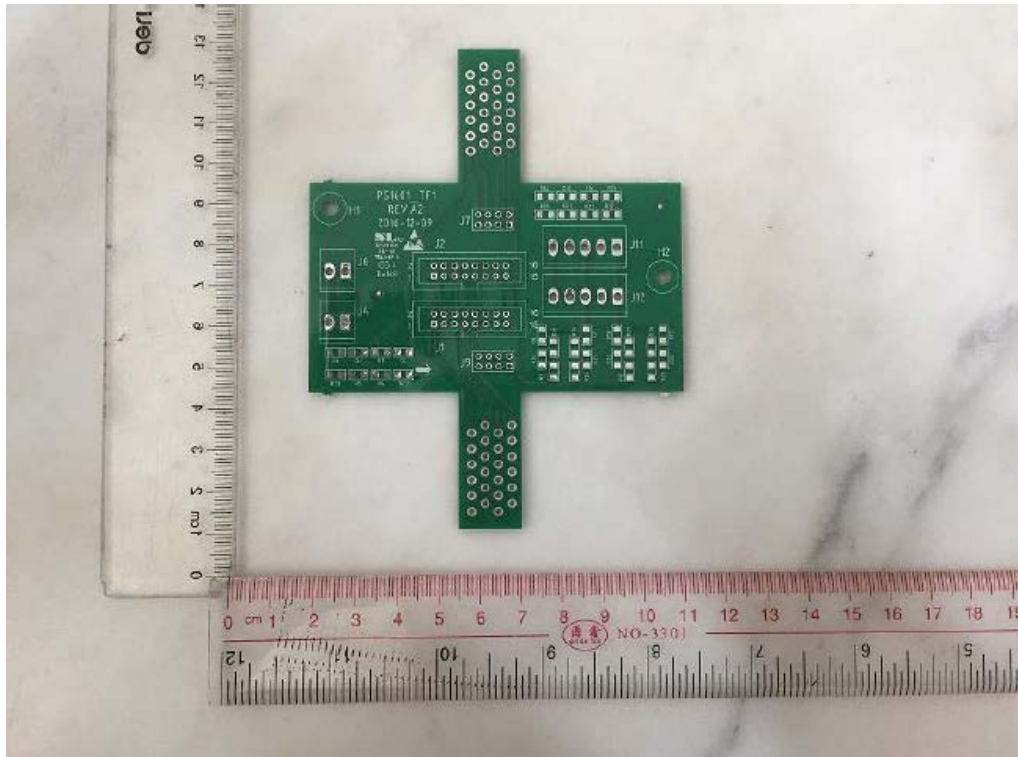

Figure 34: PCB component view

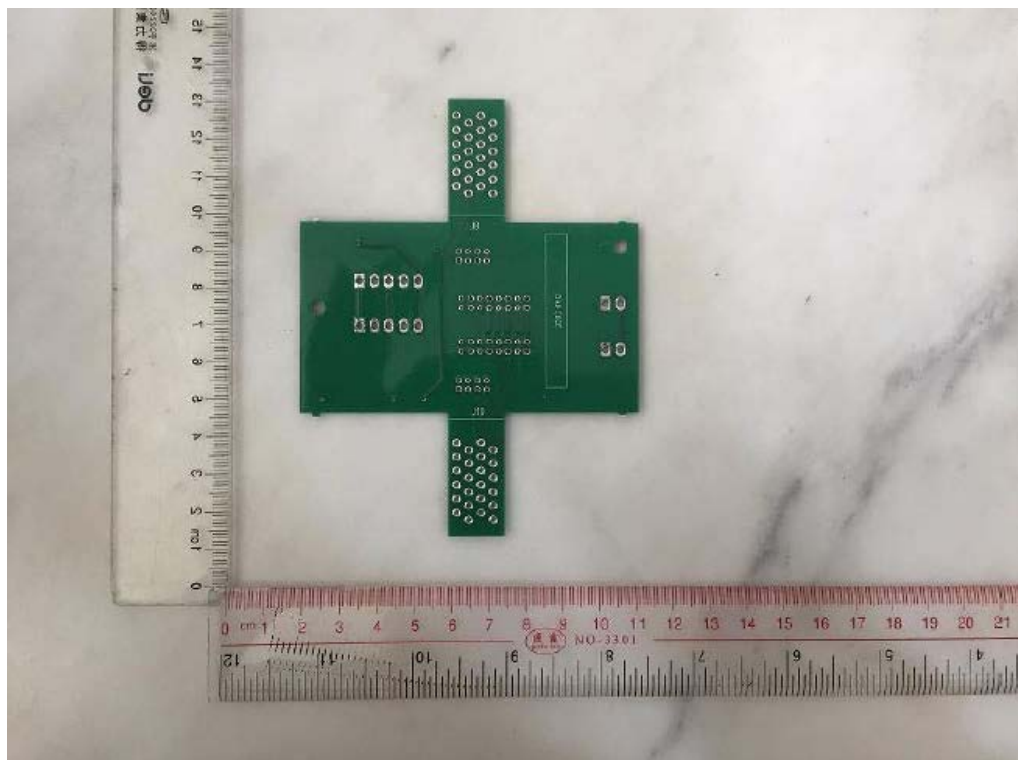

Figure 35: PCB trace view