

# SUPER<sup>®</sup>

## SUPERSERVER<sup>®</sup>

### 5018A-MLTN4

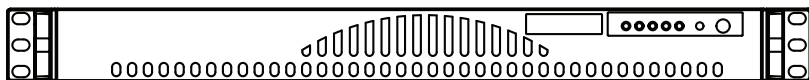

Revision 1.0b

The information in this User's Manual has been carefully reviewed and is believed to be accurate. The vendor assumes no responsibility for any inaccuracies that may be contained in this document, makes no commitment to update or to keep current the information in this manual, or to notify any person or organization of the updates. **Please Note: For the most up-to-date version of this manual, please see our web site at [www.supermicro.com](http://www.supermicro.com).**

Super Micro Computer, Inc. ("Supermicro") reserves the right to make changes to the product described in this manual at any time and without notice. This product, including software and documentation, is the property of Supermicro and/or its licensors, and is supplied only under a license. Any use or reproduction of this product is not allowed, except as expressly permitted by the terms of said license.

IN NO EVENT WILL SUPERMICRO BE LIABLE FOR DIRECT, INDIRECT, SPECIAL, INCIDENTAL, SPECULATIVE OR CONSEQUENTIAL DAMAGES ARISING FROM THE USE OR INABILITY TO USE THIS PRODUCT OR DOCUMENTATION, EVEN IF ADVISED OF THE POSSIBILITY OF SUCH DAMAGES. IN PARTICULAR, SUPERMICRO SHALL NOT HAVE LIABILITY FOR ANY HARDWARE, SOFTWARE, OR DATA STORED OR USED WITH THE PRODUCT, INCLUDING THE COSTS OF REPAIRING, REPLACING, INTEGRATING, INSTALLING OR RECOVERING SUCH HARDWARE, SOFTWARE, OR DATA.

Any disputes arising between manufacturer and customer shall be governed by the laws of Santa Clara County in the State of California, USA. The State of California, County of Santa Clara shall be the exclusive venue for the resolution of any such disputes. Super Micro's total liability for all claims will not exceed the price paid for the hardware product.

FCC Statement: This equipment has been tested and found to comply with the limits for a Class A digital device pursuant to Part 15 of the FCC Rules. These limits are designed to provide reasonable protection against harmful interference when the equipment is operated in a commercial environment. This equipment generates, uses, and can radiate radio frequency energy and, if not installed and used in accordance with the manufacturer's instruction manual, may cause harmful interference with radio communications. Operation of this equipment in a residential area is likely to cause harmful interference, in which case you will be required to correct the interference at your own expense.

California Best Management Practices Regulations for Perchlorate Materials: This Perchlorate warning applies only to products containing CR (Manganese Dioxide) Lithium coin cells. "Perchlorate Material-special handling may apply. See [www.dtsc.ca.gov/hazardouswaste/perchlorate](http://www.dtsc.ca.gov/hazardouswaste/perchlorate)"

**WARNING: Handling of lead solder materials used in this product may expose you to lead, a chemical known to the State of California to cause birth defects and other reproductive harm.**

Manual Revision 1.0a  
Release Date: October 14, 2014

Unless you request and receive written permission from Super Micro Computer, Inc., you may not copy any part of this document.

Information in this document is subject to change without notice. Other products and companies referred to herein are trademarks or registered trademarks of their respective companies or mark holders.

Copyright © 2014 by Super Micro Computer, Inc.  
All rights reserved.  
**Printed in the United States of America**

## Preface

### About This Manual

This manual is written for professional system integrators and PC technicians. It provides information for the installation and use of the SuperServer 5018A-MLTN4. Installation and maintenance should be performed by experienced technicians only.

The SuperServer 5018A-MLTN4 is a 1U rackmount server based on the SC512L-200B server chassis and the Super A1SAM-2550F motherboard. Please refer to our web site for updates on supported processors.

### Manual Organization

#### **Chapter 1: Introduction**

The first chapter provides a checklist of the main components included with the server system and describes the main features of the A1SAM-2550F motherboard and the SC512L-200B chassis.

#### **Chapter 2: Server Installation**

This chapter describes the steps necessary to install the SuperServer 5018A-MLTN4 into a rack and check out the server configuration prior to powering up the system. If your server was ordered without memory, this chapter will refer you to the appropriate section of the manual for installation.

#### **Chapter 3: System Interface**

Refer to this chapter for details on the system interface, which includes the functions and information provided by the control panel on the chassis as well as other LEDs located throughout the system.

#### **Chapter 4: Standardized Warning Statements**

You should thoroughly familiarize yourself with this chapter for a general overview of safety precautions that should be followed when installing and servicing the SuperServer 5018A-MLTN4.

## **Chapter 5: Advanced Motherboard Setup**

Chapter 5 provides detailed information on the A1SAM-2550F motherboard, including the locations and functions of connectors, headers and jumpers. Refer to this chapter when adding or removing main memory and when reconfiguring the motherboard.

## **Chapter 6: Advanced Chassis Setup**

Refer to Chapter 6 for detailed information on the SC512L-200B chassis. You should follow the procedures given in this chapter when installing, removing or reconfiguring Serial ATA or peripheral drives and when replacing system power supply units and cooling fans.

## **Chapter 7: BIOS**

The BIOS chapter includes an introduction to BIOS and provides detailed information on running the CMOS Setup Utility.

## **Appendix A: BIOS POST Error Codes**

## **Appendix B: System Specifications**

## Notes

## Table of Contents

### **Chapter 1 Introduction**

1-1	Overview .....	1-1
1-2	Motherboard Features.....	1-2
	Processors .....	1-2
	Memory .....	1-2
	SATA .....	1-2
	PCI Expansion Slots .....	1-2
	I/O Ports.....	1-2
1-3	Server Chassis Features .....	1-3
	System Power.....	1-3
	SATA Subsystem.....	1-3
	Control Panel .....	1-3
	Cooling System.....	1-3
1-4	Contacting Supermicro.....	1-5

### **Chapter 2 Server Installation**

2-1	Overview .....	2-1
2-2	Unpacking the System.....	2-1
2-3	Preparing for Setup.....	2-1
	Choosing a Setup Location.....	2-1
2-4	Warnings and Precautions.....	2-2
	Rack Precautions .....	2-2
	Server Precautions.....	2-2
	Rack Mounting Considerations .....	2-3
	Ambient Operating Temperature .....	2-3
	Reduced Airflow .....	2-3
	Mechanical Loading .....	2-3
	Circuit Overloading.....	2-3
	Reliable Ground .....	2-3
2-5	Installing the System into a Rack .....	2-4
	Identifying the Sections of the Rack Rails (Optional).....	2-4
	Installing the Inner Rail Extension .....	2-5
	Installing the Outer Rails to the Rack.....	2-6
	Installing the Chassis into a Rack.....	2-8
	Mid-Mount Telco Rack.....	2-9
	Installing the Chassis into a Rack in Mid-Mount Position .....	2-9

---

**Chapter 3 System Interface**

3-1	Overview .....	3-1
3-2	Control Panel Buttons .....	3-1
	Reset .....	3-1
	Power .....	3-1
3-3	Control Panel LEDs .....	3-2
	Overheat/Fan Fail LED .....	3-2
	NIC2 .....	3-2
	NIC1 .....	3-2
	HDD .....	3-3
	Power .....	3-3

**Chapter 4 Standardized Warning Statements for AC Systems**

4-1	About Standardized Warning Statements .....	4-1
	Warning Definition .....	4-1
	Installation Instructions .....	4-4
	Circuit Breaker .....	4-5
	Power Disconnection Warning .....	4-6
	Equipment Installation .....	4-8
	Restricted Area .....	4-9
	Battery Handling .....	4-10
	Redundant Power Supplies .....	4-12
	Backplane Voltage .....	4-13
	Comply with Local and National Electrical Codes .....	4-14
	Product Disposal .....	4-15
	Hot Swap Fan Warning .....	4-16
	Power Cable and AC Adapter .....	4-18

**Chapter 5 Advanced Motherboard Setup**

5-1	Handling the Motherboard .....	5-1
	Precautions .....	5-1
	Unpacking .....	5-2
5-2	Motherboard Installation .....	5-2
5-3	Connecting Cables .....	5-3
	Connecting Data Cables .....	5-3
	Connecting Power Cables .....	5-3
	Connecting the Control Panel .....	5-3
5-4	Rear I/O Ports .....	5-4
5-5	Onboard Processor and Heatsink .....	5-5
5-6	Installing Memory Modules .....	5-5
	Installing & Removing DIMMs .....	5-5

---

	Memory Support.....	5-6
	Memory Population Guidelines.....	5-6
5-7	Adding PCI Cards.....	5-7
5-8	Motherboard Details.....	5-8
	Motherboard Layout.....	5-8
	A1SAM-2550F Quick Reference Table.....	5-8
5-9	Connector Definitions.....	5-10
	ATX Power Connector.....	5-10
	Power Button.....	5-10
	Reset Button.....	5-10
	Power Fail LED.....	5-10
	Overheat (OH)/Fan Fail/PWR Fail/UID LED.....	5-11
	NIC2 (LAN2) LED.....	5-11
	HDD LED.....	5-11
	Power On LED.....	5-11
	NMI Button.....	5-12
	Fan Headers.....	5-12
	Chassis Intrusion.....	5-12
	Universal Serial Bus (USB).....	5-12
	Serial Ports.....	5-13
	Power SMB (I <sup>2</sup> C) Connector.....	5-13
	Onboard Speaker (SP1).....	5-13
	Power LED/Speaker.....	5-13
	DOM Power Connector.....	5-14
	TPM/Port 80 Header.....	5-14
	Overheat LED/Fan Fail.....	5-14
	LAN3/LAN4 LED Indication Header.....	5-14
	LAN (Ethernet) Ports.....	5-15
	Unit Identifier Switch/UID LED Indicators.....	5-15
	System Management Bus Header.....	5-16
	Standby Power.....	5-16
	Overheat LED Header.....	5-16
5-10	Jumper Settings.....	5-17
	Explanation of Jumpers.....	5-17
	CMOS Clear.....	5-17
	LAN1/LAN2 Enable/Disable.....	5-17
	VGA Enable/Disable.....	5-18
	Watch Dog.....	5-18
	BMC Enable.....	5-18



---

	PCI-E Slot SMB Enable .....	5-18
	BIOS Recovery Enable .....	5-19
	USB Wake-Up Enable .....	5-19
5-11	Onboard Indicators .....	5-19
	LAN Port LEDs .....	5-19
	IPMI Dedicated LAN LEDs .....	5-19
	Onboard Power LED .....	5-20
	Overheat/PWR Fail/Fan Fail LED .....	5-20
	Unit Identification LED .....	5-20
5-12	SATA Ports .....	5-21
	SATA Ports .....	5-21
5-13	Installing Software .....	5-22
	SuperDoctor® 5 .....	5-23
5-14	Onboard Battery .....	5-24
<b>Chapter 6 Advanced Chassis Setup</b>		
6-1	Static-Sensitive Devices .....	6-1
	Precautions .....	6-1
	Unpacking .....	6-1
6-2	Control Panel .....	6-2
6-3	Removing the Chassis Cover .....	6-2
6-4	System Fan .....	6-3
6-5	Installing Hard Drives .....	6-5
6-6	PCI Slot Setup .....	6-7
6-7	Power Supply .....	6-8
	Power Supply Failure .....	6-8
<b>Chapter 7 BIOS</b>		
7-1	Introduction .....	7-1
7-2	Main Setup .....	7-2
7-3	Advanced Setup Configurations .....	7-4
7-4	IPMI Configuration .....	7-20
7-4	Event Logs .....	7-22
7-5	Security Settings .....	7-24
7-6	Boot Settings .....	7-27
7-7	Save & Exit .....	7-29
<b>Appendix A BIOS Post Error Codes</b>		
<b>Appendix B System Specifications</b>		

---

# Notes

# Chapter 1

## Introduction

### 1-1 Overview

The SuperServer 5018A-MLTN4 is comprised of two main subsystems: the SC512L-200B 1U chassis and the A1SAM-2550F motherboard. Please refer to our web site for information on operating systems that have been certified for use with the SuperServer 5018A-MLTN4 ([www.supermicro.com](http://www.supermicro.com)).

In addition to the motherboard and chassis, various hardware components have been included with the system, as listed below:

- One 10-cm PWM blower fan (FAN-0038L4)

**Note:** For your system to work properly, please follow the links below to download all necessary drivers/utilities and the user's manual for your server.

- Supermicro product manuals: <http://www.supermicro.com/support/manuals/>
- Product drivers and utilities: <ftp://ftp.supermicro.com>
- Product safety info: [http://super-dev/about/policies/safety\\_information.cfm](http://super-dev/about/policies/safety_information.cfm)
- If you have any questions, please contact our support team at: [support@supermicro.com](mailto:support@supermicro.com)

## 1-2 Motherboard Features

At the heart of the SuperServer 5018A-MLTN4 lies the A1SAM-2550F, an embedded processor motherboard. Below are the main features of the A1SAM-2550F. See Figure 1-1 for a block diagram of the motherboard.

### Processors

The A1SAM-2550F supports a single Intel® C2000 Tri-Gate 22nm SoC (System-on-a Chip) Series 4-core processor in an FCBGA 1283 package (embedded processor).

### Memory

The A1SAM-2550F has four DIMM slots that can support up to 64GB of DDR3-1600/1333 Unbuffered (UDIMM) ECC/Non-ECC memory. DIMMs of the same size and speed should be used. See Chapter 5 for details.

### SATA

A SATA controller is integrated into the chipset to provide a six-port Serial ATA subsystem (4x SATA 2.0 and 2x SATA 3.0 ports). The SATA drives are hot-swappable units.

### PCI Expansion Slots

The motherboard includes one PCI-Express 2.0 x8 and one PCI-Express 2.0 x4 slot. The system supports one PCI-Express 2.0 x8 card with the use of an optional installed riser card.

### I/O Ports

The I/O ports include a COM port, a VGA port, four USB 2.0 ports, four Gb LAN (NIC) ports and a dedicated IPMI LAN port.

## 1-3 Server Chassis Features

The following is a general outline of the main features of the SC512L-200B chassis.

### **System Power**

The SC512L-200B chassis includes a single 200W power supply.

### **SATA Subsystem**

The SC512L-200B chassis was designed to support two internal 3.5" SATA hard drives.

### **Control Panel**

The SC512L-200B's control panel provides important system monitoring and control information. LEDs indicate power on, network activity, hard disk drive activity and system overheat conditions. The control panel also includes a main power button and a system reset button.

### **Cooling System**

The SC512L-200B chassis features one 10-cm PWM blower fan, which connects to a chassis fan header on the motherboard. Fan speed is controlled by IPMI.

**Figure 1-1. A1SAM-2550F Motherboard:  
System Block Diagram**

**Note:** This is a general block diagram. Please see Chapter 5 for details.

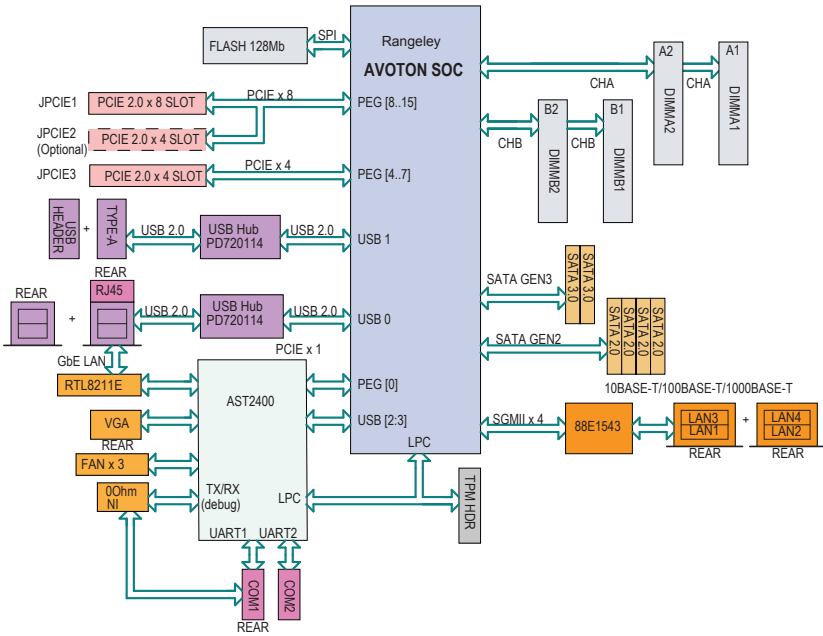

## 1-4 Contacting Supermicro

### Headquarters

Address: Super Micro Computer, Inc.  
980 Rock Ave.  
San Jose, CA 95131 U.S.A.

Tel: +1 (408) 503-8000

Fax: +1 (408) 503-8008

Email: [marketing@supermicro.com](mailto:marketing@supermicro.com) (General Information)  
[support@supermicro.com](mailto:support@supermicro.com) (Technical Support)

Website: [www.supermicro.com](http://www.supermicro.com)

### Europe

Address: Super Micro Computer B.V.  
Het Sterrenbeeld 28, 5215 ML  
's-Hertogenbosch, The Netherlands

Tel: +31 (0) 73-6400390

Fax: +31 (0) 73-6416525

Email: [sales@supermicro.nl](mailto:sales@supermicro.nl) (General Information)  
[support@supermicro.nl](mailto:support@supermicro.nl) (Technical Support)  
[rma@supermicro.nl](mailto:rma@supermicro.nl) (Customer Support)

Website: [www.supermicro.nl](http://www.supermicro.nl)

### Asia-Pacific

Address: Super Micro Computer, Inc.  
3F, No. 150, Jian 1st Rd.  
Zhonghe Dist., New Taipei City 235  
Taiwan (R.O.C)

Tel: +886-(2) 8226-3990

Fax: +886-(2) 8226-3992

Email: [support@supermicro.com.tw](mailto:support@supermicro.com.tw)

Website: [www.supermicro.com.tw](http://www.supermicro.com.tw)

## Notes



## Chapter 2

# Server Installation

### 2-1 Overview

This chapter provides a quick setup checklist to get your SuperServer 5018A-MLTN4 up and running. Following the steps in the order given should enable you to have the system operational within a minimal amount of time. This quick setup assumes that your system has come to you with the processor and memory preinstalled. If your system is not already fully integrated with a motherboard, processor, system memory etc., please turn to the chapter or section noted in each step for details on installing specific components.

### 2-2 Unpacking the System

You should inspect the box the server was shipped in and note if it was damaged in any way. If the server itself shows damage, you should file a damage claim with the carrier who delivered it.

Decide on a suitable location for the rack unit that will hold the server. It should be situated in a clean, dust-free area that is well ventilated. Avoid areas where heat, electrical noise and electromagnetic fields are generated. You will also need it placed near a grounded power outlet. Read the Rack and Server Precautions in the next section.

### 2-3 Preparing for Setup

The 5018A-MLTN4 may have shipped with an optional rack mount kit to install the system into the rack. Follow the steps in the order given to complete the installation process in a minimal amount of time. Please read this section in its entirety before you begin the installation procedure outlined in the sections that follow.

#### Choosing a Setup Location

- Leave enough clearance in front of the rack to enable you to open the front door completely (~25 inches) and approximately 30 inches of clearance in the back of the rack to allow for sufficient airflow and ease in servicing. This product is for installation only in a Restricted Access Location (dedicated equipment rooms, service closets and the like).

- This product is not suitable for use with visual display work place devices according to §2 of the the German Ordinance for Work with Visual Display Units.

## 2-4 Warnings and Precautions

### Rack Precautions

- Ensure that the leveling jacks on the bottom of the rack are fully extended to the floor with the full weight of the rack resting on them.
- In single rack installation, stabilizers should be attached to the rack. In multiple rack installations, the racks should be coupled together.
- Always make sure the rack is stable before extending a component from the rack.
- You should extend only one component at a time - extending two or more simultaneously may cause the rack to become unstable.

### Server Precautions

- Review the electrical and general safety precautions in Chapter 4.
- Determine the placement of each component in the rack *before* you install the rails.
- Install the heaviest server components on the bottom of the rack first, and then work up.
- Use a regulating uninterruptible power supply (UPS) to protect the server from power surges, voltage spikes and to keep your system operating in case of a power failure.
- Allow the hot plug SATA drives and power supply modules to cool before touching them.
- Always keep the rack's front door and all panels and components on the servers closed when not servicing to maintain proper cooling.

## Rack Mounting Considerations

### ***Ambient Operating Temperature***

If installed in a closed or multi-unit rack assembly, the ambient operating temperature of the rack environment may be greater than the ambient temperature of the room. Therefore, consideration should be given to installing the equipment in an environment compatible with the manufacturer's maximum rated ambient temperature (T<sub>mra</sub>).

### ***Reduced Airflow***

Equipment should be mounted into a rack so that the amount of airflow required for safe operation is not compromised.

### ***Mechanical Loading***

Equipment should be mounted into a rack so that a hazardous condition does not arise due to uneven mechanical loading.

### ***Circuit Overloading***

Consideration should be given to the connection of the equipment to the power supply circuitry and the effect that any possible overloading of circuits might have on overcurrent protection and power supply wiring. Appropriate consideration of equipment nameplate ratings should be used when addressing this concern.

### ***Reliable Ground***

A reliable ground must be maintained at all times. To ensure this, the rack itself should be grounded. Particular attention should be given to power supply connections other than the direct connections to the branch circuit (i.e. the use of power strips, etc.).



**Warning!** To prevent bodily injury when mounting or servicing this unit in a rack, you must take special precautions to ensure that the system remains stable. The following guidelines are provided to ensure your safety:

- This unit should be mounted at the bottom of the rack if it is the only unit in the rack.
- When mounting this unit in a partially filled rack, load the rack from the bottom to the top with the heaviest component at the bottom of the rack.
- If the rack is provided with stabilizing devices, install the stabilizers before mounting or servicing the unit in the rack.

## 2-5 Installing the System into a Rack

This section provides information on installing the SuperServer 5018A-MLTN4 into a rack unit with the optional rack rails.

There are a variety of rack units on the market, which may mean the assembly procedure will differ slightly. You should also refer to the installation instructions that came with the rack unit you are using.

### Identifying the Sections of the Rack Rails (Optional)

The chassis package includes two rack rail assemblies in the rack mounting kit. Each assembly consists of two sections: an inner fixed chassis rail that secures directly to the server chassis, and an outer fixed rack rail that secures directly to the rack itself. The SC512F comes with "chassis ears" that allow the chassis to use generic rails.

Figure 2-1. Identifying the Sections of the Rack Rails  
(Right side rail shown)

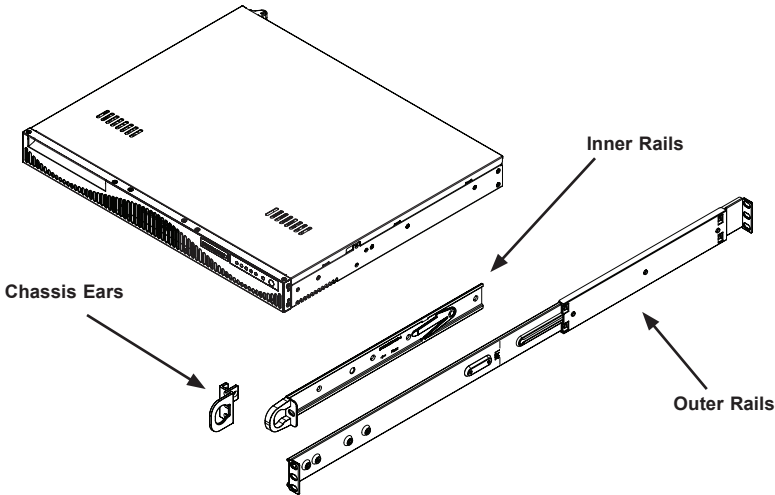

## Installing the Inner Rail Extension

The SC512F includes chassis ears that you must remove before installing the rails.

### **Removing the Chassis Ears**

1. Locate and remove the three screws holding the chassis ear in place.
2. Repeat step on with the other chassis ear.

**Figure 2-2. Installing Rear Inner Chassis Rails**

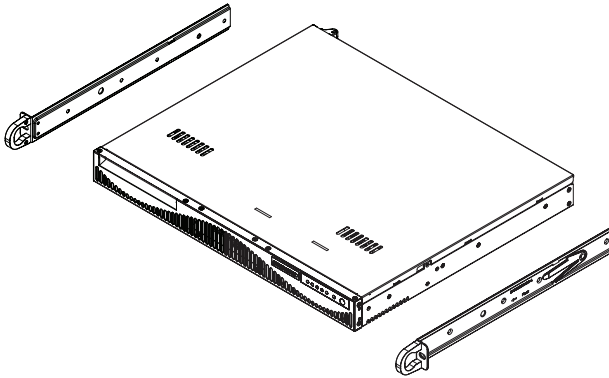

### **Installing the Inner Rails**

1. Place the inner rail on the side of the chassis aligning the hooks of the chassis with the rail holes.
2. Slide the rail toward the front of the chassis to secure the rail in place.
3. Secure the chassis with four screws.
4. Repeat steps 1-3 for the other inner rail extension.

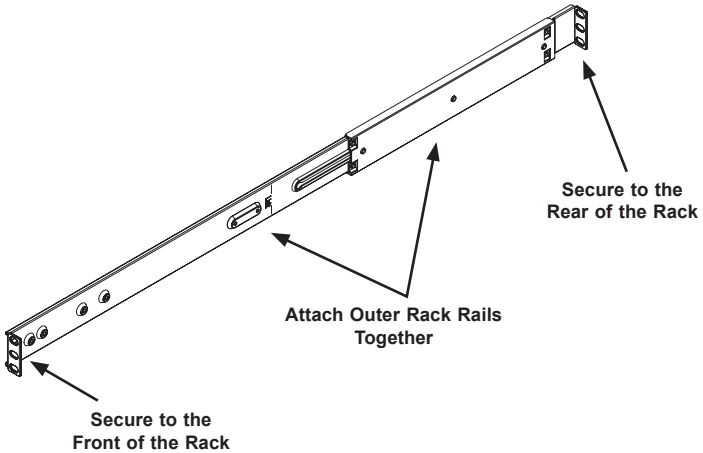

Figure 2-3. Assembling the Outer Rails

## Installing the Outer Rails to the Rack

### *Installing the Outer Rails*

1. Attach the short bracket to the outside of the long bracket. You must align the pins with the slides. Also, both bracket ends must face the same direction.
2. Adjust both the short and long brackets to the proper distance so that the rail fits snugly into the rack.
3. Secure the long bracket to the front side of the outer rail with two M5 screws and the short bracket to the rear side of the outer rail with three M5 screws. Use a washer with each screw.
4. Repeat steps 1-4 for the left outer rail.



**Warning:** do not pick up the server with the front handles. They are designed to pull the system from a rack only.

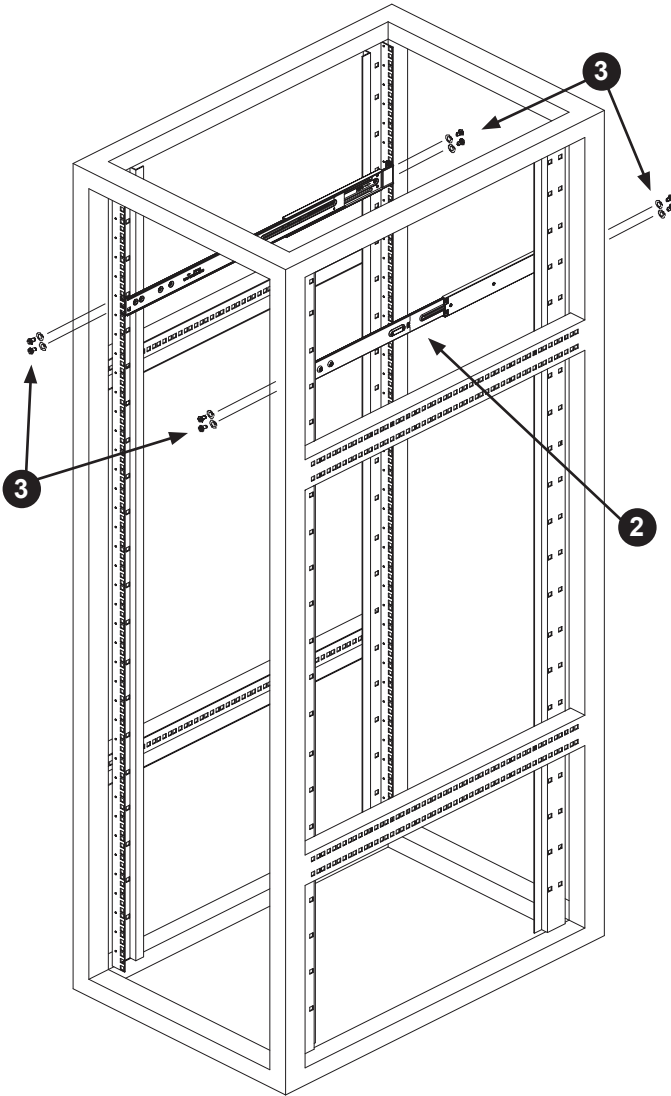
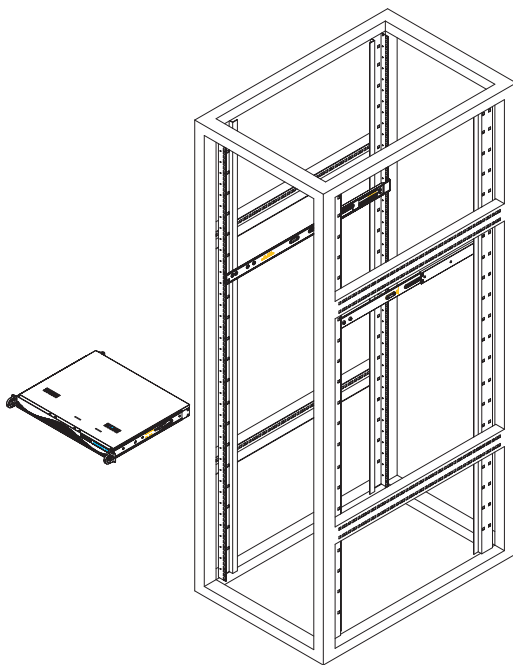

**Figure 2-4. Installing the Outer Rails to the Server Rack**

**Note:** this figure is for illustrative purposes only. Always install servers to the bottom of a rack first.



Stability hazard. The rack stabilizing mechanism must be in place, or the rack must be bolted to the floor before you slide the unit out for servicing. Failure to stabilize the rack can cause the rack to tip over.



**Figure 2-5. Installing the Chassis into a Rack**

## Installing the Chassis into a Rack

### *Installing the Chassis*

1. Confirm that the inner rails are attached to the chassis. Also, confirm that the outer rails are installed on the rack.
2. Align chassis rails with the front of the rack rails.
3. Slide the chassis rails into the rack rails, keeping the pressure even on both sides (It may be necessary to depress the locking tabs when inserting). When the server has been pushed completely into the rack, you should hear the locking tabs "click" into the locked position.
4. (Optional) Insert and tightening the thumbscrews that hold the front of the server to the rack.

**Note:** this figure is for illustrative purposes only. Always install servers to the bottom of a rack first.



## Mid-Mount Telco Rack

The SC512 supports Telco rack installation. The SC512 chassis compact design allows the chassis to be installed into a Telco rack without the use of rails.

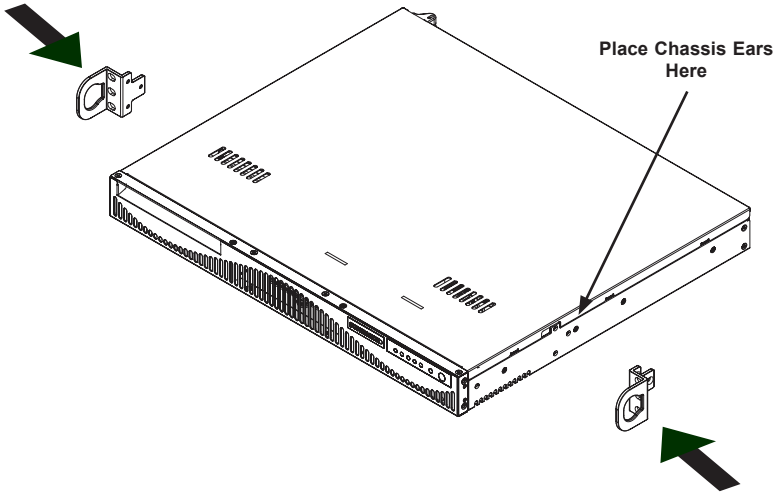
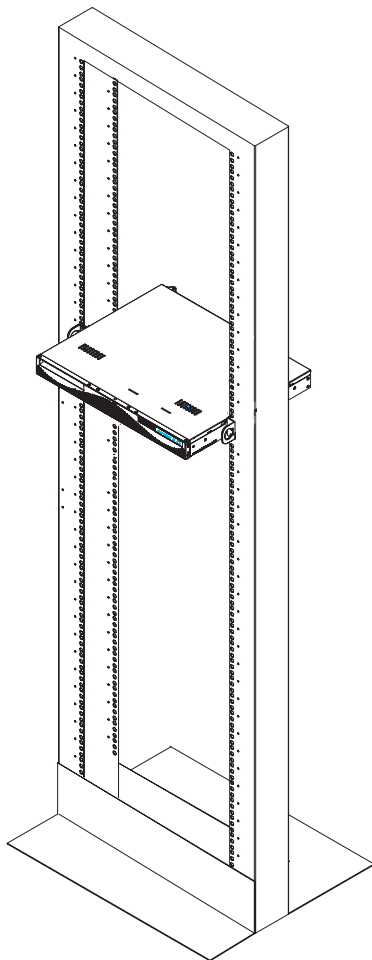

Figure 2-6. Placing the Chassis Ears for Telco Rack Installation

## Installing the Chassis into a Rack in Mid-Mount Position

### *Instaling into a Mid-Mount Position Rack*

1. If it is necessary to install the chassis in a mid-mount Telco rack, remove the chassis rails and the chassis ears (if the ears are installed at the front of the chassis).
2. Locate the three screw holes in the middle of the chassis and secure the ears to the chassis with three flat head screws. Make sure the screws are secure, but do not over tighten the screws.



**Figure 2-7. Installing the Server into a Telco Rack**

1. Hold the chassis in the telco rack and screw the chassis to the rack using the three screw holes located in the chassis ears.
2. The chassis is held in place by the chassis ears and does not slide in and out of place.

**Note:** this figure is for illustrative purposes only. Always install servers to the bottom of a rack first.

---

---

## Chapter 3

# System Interface

### 3-1 Overview

There are several LEDs on the control panel as well as others on the SATA drive carriers to keep you constantly informed of the overall status of the system as well as the activity and health of specific components. There are also two buttons on the chassis control panel and an on/off switch on the power supply. This chapter explains the meanings of all LED indicators and the appropriate response you may need to take.

### 3-2 Control Panel Buttons

There are two push-buttons located on the front of the chassis: a reset button and a power on/off button.

RESET



#### Reset

The reset button reboots the system.



#### Power

This is the main power button, which is used to apply or turn off the main system power. Turning off system power with this button removes the main power but keeps standby power supplied to the system.

### 3-3 Control Panel LEDs

The control panel located on the front of the SC512L-200B chassis has five LEDs. These LEDs provide you with critical information related to different parts of the system. This section explains what each LED indicates when illuminated and any corrective action you may need to take.



#### Overheat/Fan Fail LED

When this LED flashes it indicates a fan failure. When continuously on (not flashing) it indicates an overheat condition, which may be caused by cables obstructing the airflow in the system or the ambient room temperature being too warm.

Check the routing of the cables and make sure all fans are present and operating normally. You should also check to make sure that the chassis covers are installed. Finally, verify that the heatsinks are installed properly. This LED will remain flashing or on as long as the overheat condition exists.



#### NIC2

Indicates network activity on LAN2 when flashing.



#### NIC1

Indicates network activity on LAN1 when flashing.



### **HDD**

Channel activity for all HDDs. This light indicates SATA drive activity on the 5018A-MLTN4 when flashing.



### **Power**

Indicates power is being supplied to the system's power supply units. This LED should normally be illuminated when the system is operating.

## Notes

## Chapter 4

# Standardized Warning Statements for AC Systems

### 4-1 About Standardized Warning Statements

The following statements are industry standard warnings, provided to warn the user of situations which have the potential for bodily injury. Should you have questions or experience difficulty, contact Supermicro's Technical Support department for assistance. Only certified technicians should attempt to install or configure components.

Read this appendix in its entirety before installing or configuring components in the Supermicro chassis.

These warnings may also be found on our web site at [http://www.supermicro.com/about/policies/safety\\_information.cfm](http://www.supermicro.com/about/policies/safety_information.cfm).

#### Warning Definition



#### Warning!

This warning symbol means danger. You are in a situation that could cause bodily injury. Before you work on any equipment, be aware of the hazards involved with electrical circuitry and be familiar with standard practices for preventing accidents.

#### 警告の定義

この警告サインは危険を意味します。

人身事故につながる可能性がありますので、いずれの機器でも動作させる前に、電気回路に含まれる危険性に注意して、標準的な事故防止策に精通して下さい。

此警告符号代表危險。

您正处于可能受到严重伤害的工作环境中。在您使用设备开始工作之前，必须充分意识到触电的危险，并熟练掌握防止事故发生的标准工作程序。请根据每项警告结尾的声明号码找到此设备的安全性警告说明的翻译文本。

此警告符號代表危險。

您正處於可能身體可能會受損傷的工作環境中。在您使用任何設備之前，請注意觸電的危險，並且要熟悉預防事故發生的標準工作程序。請依照每一注意事項後的號碼找到相關的翻譯說明內容。

## Warnung

### WICHTIGE SICHERHEITSHINWEISE

Dieses Warnsymbol bedeutet Gefahr. Sie befinden sich in einer Situation, die zu Verletzungen führen kann. Machen Sie sich vor der Arbeit mit Geräten mit den Gefahren elektrischer Schaltungen und den üblichen Verfahren zur Vorbeugung vor Unfällen vertraut. Suchen Sie mit der am Ende jeder Warnung angegebenen Anweisungsnummer nach der jeweiligen Übersetzung in den übersetzten Sicherheitshinweisen, die zusammen mit diesem Gerät ausgeliefert wurden.

BEWAHREN SIE DIESE HINWEISE GUT AUF.

### INSTRUCCIONES IMPORTANTES DE SEGURIDAD

Este símbolo de aviso indica peligro. Existe riesgo para su integridad física. Antes de manipular cualquier equipo, considere los riesgos de la corriente eléctrica y familiarícese con los procedimientos estándar de prevención de accidentes. Al final de cada advertencia encontrará el número que le ayudará a encontrar el texto traducido en el apartado de traducciones que acompaña a este dispositivo.

GUARDE ESTAS INSTRUCCIONES.

### IMPORTANTES INFORMATIONS DE SÉCURITÉ

Ce symbole d'avertissement indique un danger. Vous vous trouvez dans une situation pouvant entraîner des blessures ou des dommages corporels. Avant de travailler sur un équipement, soyez conscient des dangers liés aux circuits électriques et familiarisez-vous avec les procédures couramment utilisées pour éviter les accidents. Pour prendre connaissance des traductions des avertissements figurant dans les consignes de sécurité traduites qui accompagnent cet appareil, référez-vous au numéro de l'instruction situé à la fin de chaque avertissement.

CONSERVEZ CES INFORMATIONS.

## **תקנת הצהרות אזהרה**

הצהרות הבאות הן אזהרות על פי תקני התעשייה, על מנת להזהיר את המשתמש מפני חבלה פיזית אפשרית. במידה ויש שאלות או היתקלות בבעיה כלשהי, יש ליצור קשר עם מחלקת תמיכה טכנית של סופרמיקרו. טכנאים מוסמכים בלבד רשאים להתקין או להגדיר את הרכיבים.

יש לקרוא את הנספח במלוואו לפני התקנת או הגדרת הרכיבים במארוזי סופרמיקרו.



تحذير! هذا الرمز يعني خطر انك في حالة يمكن أن تتسبب في اصابة جسدية .  
قبل أن تعمل على أي معدات، كن على علم بالمخاطر الناجمة عن الدوائر  
الكهربائية  
وكن على دراية بالممارسات الوقائية لمنع وقوع أي حوادث  
استخدم رقم البيان المنصوص في نهاية كل تحذير للعثور ترجمتها

안전을 위한 주의사항

경고!

이 경고 기호는 위험이 있음을 알려 줍니다. 작업자의 신체에 부상을 야기 할 수 있는 상태에 있게 됩니다. 모든 장비에 대한 작업을 수행하기 전에 전기회로와 관련된 위험요소들을 확인하시고 사전에 사고를 방지할 수 있도록 표준 작업절차를 준수해 주시기 바랍니다.

해당 번역문을 찾기 위해 각 경고의 마지막 부분에 제공된 경고문 번호를 참조하십시오

#### BELANGRIJKE VEILIGHEIDSINSTRUCTIES

Dit waarschuwings symbool betekent gevaar. U verkeert in een situatie die lichamelijk letsel kan veroorzaken. Voordat u aan enige apparatuur gaat werken, dient u zich bewust te zijn van de bij een elektrische installatie betrokken risico's en dient u op de hoogte te zijn van de standaard procedures om ongelukken te voorkomen. Gebruik de nummers aan het eind van elke waarschuwing om deze te herleiden naar de desbetreffende locatie.

BEWAAR DEZE INSTRUCTIES

## Installation Instructions



### Warning!

Read the installation instructions before connecting the system to the power source.

設置手順書

システムを電源に接続する前に、設置手順書をお読み下さい。

警告

将此系统连接电源前，请先阅读安装说明。

警告

將系統與電源連接前，請先閱讀安裝說明。

Warnung

Vor dem Anschließen des Systems an die Stromquelle die Installationsanweisungen lesen.

¡Advertencia!

Lea las instrucciones de instalación antes de conectar el sistema a la red de alimentación.

Attention

Avant de brancher le système sur la source d'alimentation, consulter les directives d'installation.

יש לקרוא את הוראות התקנה לפני חיבור המערכת למקור מתח.

اقرأ إرشادات التركيب قبل توصيل النظام إلى مصدر للطاقة

시스템을 전원에 연결하기 전에 설치 안내를 읽어주십시오.

Waarschuwing

Raadpleeg de installatie-instructies voordat u het systeem op de voedingsbron aansluit.

## Circuit Breaker



### Warning!

This product relies on the building's installation for short-circuit (overcurrent) protection. Ensure that the protective device is rated not greater than: 250 V, 20 A.

サーキット・ブレーカー

この製品は、短絡(過電流)保護装置がある建物での設置を前提としています。

保護装置の定格が250 V、20 Aを超えないことを確認下さい。

### 警告

此产品的短路(过载电流)保护由建筑物的供电系统提供,确保短路保护设备的额定电流不大于250V,20A。

### 警告

此产品的短路(过载电流)保护由建筑物的供电系统提供,确保短路保护设备的额定电流不大于250V,20A。

### Warnung

Dieses Produkt ist darauf angewiesen, dass im Gebäude ein Kurzschluss- bzw. Überstromschutz installiert ist. Stellen Sie sicher, dass der Nennwert der Schutzvorrichtung nicht mehr als: 250 V, 20 A beträgt.

### ¡Advertencia!

Este equipo utiliza el sistema de protección contra cortocircuitos (o sobrecorrientes) del edificio. Asegúrese de que el dispositivo de protección no sea superior a: 250 V, 20 A.

### Attention

Pour ce qui est de la protection contre les courts-circuits (surtension), ce produit dépend de l'installation électrique du local. Vérifiez que le courant nominal du dispositif de protection n'est pas supérieur à :250 V, 20 A.

מוצר זה מסתמך על הגנה המותקנת במבנים למניעת קצר חשמלי. יש לוודא  
המכשיר המגן מפני הקצר החשמלי הוא לא יותר מ-60VDC, 20A

هذا المنتج يعتمد على معدات الحماية من الدوائر القصيرة التي تم تثبيتها في  
المبنى

تأكد من أن تقيّم الجهاز الوقائي ليس أكثر من: 20A, 250VDC

경고!

이 제품은 전원의 단락(과전류)방지에 대해서 전적으로 건물의 관련 설비에 의존합니다. 보호장치의 정격이 반드시 250V(볼트), 20A(암페어)를 초과하지 않도록 해야 합니다.

#### Waarschuwing

Dit product is afhankelijk van de kortsluitbeveiliging (overspanning) van uw elektrische installatie. Controleer of het beveiligde apparaat niet groter gedimensioneerd is dan 220V, 20A.

### Power Disconnection Warning



#### Warning!

The system must be disconnected from all sources of power and the power cord removed from the power supply module(s) before accessing the chassis interior to install or remove system components.

#### 電源切斷の警告

システムコンポーネントの取り付けまたは取り外しのために、シャーシ内部にアクセスするには、

システムの電源はすべてのソースから切斷され、電源コードは電源モジュールから取り外す必要があります。

#### 警告

在你打开机箱并安装或移除内部器件前，必须将系统完全断电，并移除电源线。

#### 警告

在您打開機殼安裝或移除內部元件前，必須將系統完全斷電，並移除電源線。

#### Warnung

Das System muss von allen Quellen der Energie und vom Netzanschlusskabel getrennt sein, das von den Spg.Versorgungsteilmodulen entfernt wird, bevor es auf den Chassisinnenraum zurückgreift, um Systemsbestandteile anzubringen oder zu entfernen.

¡Advertencia!

El sistema debe ser disconnected de todas las fuentes de energía y del cable eléctrico quitado de los módulos de fuente de alimentación antes de tener acceso el interior del chasis para instalar o para quitar componentes de sistema.

Attention

Le système doit être débranché de toutes les sources de puissance ainsi que de son cordon d'alimentation secteur avant d'accéder à l'intérieur du châssis pour installer ou enlever des composants de système.

**אזהרה!**

יש לנתק את המערכת מכל מקורות החשמל ויש להסיר את כבל החשמלי מהספק לפני גישה לחלק הפנימי של המארז לצורך התקנת או הסרת רכיבים.

يجب فصل النظام من جميع مصادر الطاقة وإزالة سلك الكهرباء من وحدة امداد الطاقة قبل الوصول إلى المناطق الداخلية للهيكल لتثبيت أو إزالة مكونات الجهاز

경고!

시스템에 부품들을 장착하거나 제거하기 위해서는 새시 내부에 접근하기 전에 반드시 전원 공급장치로부터 연결되어있는 모든 전원과 전기코드를 분리해주어야 합니다.

Waarschuwing

Voordat u toegang neemt tot het binnenwerk van de behuizing voor het installeren of verwijderen van systeem onderdelen, dient u alle spanningsbronnen en alle stroomkabels aangesloten op de voeding(en) van de behuizing te verwijderen

## Equipment Installation



### Warning!

Only trained and qualified personnel should be allowed to install, replace, or service this equipment.

### 機器の設置

トレーニングを受け認定された人だけがこの装置の設置、交換、またはサービスを許可されています。

### 警告

只有经过培训且具有资格的人员才能进行此设备的安装、更换和维修。

### 警告

只有經過受訓且具資格人員才可安裝、更換與維修此設備。

### Warnung

Das Installieren, Ersetzen oder Bedienen dieser Ausrüstung sollte nur geschultem, qualifiziertem Personal gestattet werden.

### ¡Advertencia!

Solamente el personal calificado debe instalar, reemplazar o utilizar este equipo.

### Attention

Il est vivement recommandé de confier l'installation, le remplacement et la maintenance de ces équipements à des personnels qualifiés et expérimentés.

### אזהרה!

צוות מוסמך בלבד רשאי להתקין, להחליף את הציוד או לתת שירות עבור הציוד.

يجب أن يسمح فقط للموظفين المؤهلين والمدربين لتثبيت واستبدال أو خدمة هذا الجهاز

### 경고!

훈련을 받고 공인된 기술자만이 이 장비의 설치, 교체 또는 서비스를 수행할 수 있습니다.

## Waarschuwing

Deze apparatuur mag alleen worden geïnstalleerd, vervangen of hersteld door geschoold en gekwalificeerd personeel.

## Restricted Area



### Warning!

This unit is intended for installation in restricted access areas. A restricted access area can be accessed only through the use of a special tool, lock and key, or other means of security. (This warning does not apply to workstations).

## アクセス制限区域

このユニットは、アクセス制限区域に設置されることを想定しています。

アクセス制限区域は、特別なツール、鍵と錠前、その他のセキュリティの手段を用いてのみ出入りが可能です。

## 警告

此部件应安装在限制进出的场所，限制进出的场所指只能通过使用特殊工具、锁和钥匙或其它安全手段进出的场所。

## 警告

此裝置僅限安裝於進出管制區域，進出管制區域係指僅能以特殊工具、鎖頭及鑰匙或其他安全方式才能進入的區域。

## Warnung

Diese Einheit ist zur Installation in Bereichen mit beschränktem Zutritt vorgesehen. Der Zutritt zu derartigen Bereichen ist nur mit einem Spezialwerkzeug, Schloss und Schlüssel oder einer sonstigen Sicherheitsvorkehrung möglich.

## ¡Advertencia!

Esta unidad ha sido diseñada para instalación en áreas de acceso restringido. Sólo puede obtenerse acceso a una de estas áreas mediante la utilización de una herramienta especial, cerradura con llave u otro medio de seguridad.

## Attention

Cet appareil doit être installée dans des zones d'accès réservés. L'accès à une zone d'accès réservé n'est possible qu'en utilisant un outil spécial, un mécanisme de verrouillage et une clé, ou tout autre moyen de sécurité.

## אזור עם גישה מוגבלת

### אזהרה!

יש להתקין את היחידה באזורים שיש בהם הגבלת גישה. הגישה ניתנת בעזרת כלי אבטחה בלבד (מפתח, מנעול וכד').

تم تخصيص هذه الوحدة لت تركيبها في مناطق محظورة .  
يمكن الوصول إلى منطقة محظورة فقط من خلال استخدام أداة خاصة،  
قفل ومفتاح أو أي وسيلة أخرى للأمان

경고!

이 장치는 접근이 제한된 구역에 설치하도록 되어있습니다. 특수도구, 잠금 장치 및 키, 또는 기타 보안 수단을 통해서만 접근 제한 구역에 들어갈 수 있습니다.

Waarschuwing

Dit apparaat is bedoeld voor installatie in gebieden met een beperkte toegang. Toegang tot dergelijke gebieden kunnen alleen verkregen worden door gebruik te maken van speciaal gereedschap, slot en sleutel of andere veiligheidsmaatregelen.

## Battery Handling



### Warning!

There is the danger of explosion if the battery is replaced incorrectly. Replace the battery only with the same or equivalent type recommended by the manufacturer. Dispose of used batteries according to the manufacturer's instructions

電池の取り扱い

電池交換が正しく行われなかった場合、破裂の危険性があります。交換する電池はメーカーが推奨する型、または同等のものを使用下さい。使用済電池は製造元の指示に従って処分して下さい。

警告

電池更換不當會有爆炸危險。請只使用同類電池或製造商推薦的功能相當的電池更換原有電池。請按製造商的說明處理廢舊電池。

警告

電池更換不當會有爆炸危險。請使用製造商建議之相同或功能相當的電池更換原有電池。請按照製造商的說明指示處理廢棄舊電池。



### Warnung

Bei Einsetzen einer falschen Batterie besteht Explosionsgefahr. Ersetzen Sie die Batterie nur durch den gleichen oder vom Hersteller empfohlenen Batterietyp. Entsorgen Sie die benutzten Batterien nach den Anweisungen des Herstellers.

### Attention

Danger d'explosion si la pile n'est pas remplacée correctement. Ne la remplacer que par une pile de type semblable ou équivalent, recommandée par le fabricant. Jeter les piles usagées conformément aux instructions du fabricant.

### ¡Advertencia!

Existe peligro de explosión si la batería se reemplaza de manera incorrecta. Reemplazar la batería exclusivamente con el mismo tipo o el equivalente recomendado por el fabricante. Desechar las baterías gastadas según las instrucciones del fabricante.

### **אזהרה!**

קיימת סכנת פיצוץ של הסוללה במידה והוחלפה בדרך לא תקינה. יש להחליף את הסוללה בסוג התואם מחברת יצרן מומלצת.

סילוק הסוללות המשומשות יש לבצע לפי הוראות היצרן.

هناك خطر من انفجار في حالة استبدال البطارية بطريقة غير صحيحة فعليك استبدال البطارية فقط بنفس النوع أو ما يعادلها كما أوصت به الشركة المصنعة تخلص من البطاريات المستعملة وفقا لتعليمات الشركة الصانعة

### 경고!

배터리가 올바르게 교체되지 않으면 폭발의 위험이 있습니다. 기존 배터리와 동일하거나 제조사에서 권장하는 동등한 종류의 배터리로만 교체해야 합니다. 제조사의 안내에 따라 사용된 배터리를 처리하여 주십시오.

### Waarschuwing

Er is ontploffingsgevaar indien de batterij verkeerd vervangen wordt. Vervang de batterij slechts met hetzelfde of een equivalent type die door de fabrikant aanbevolen wordt. Gebruikte batterijen dienen overeenkomstig fabrieksvoorschriften afgevoerd te worden.

## Redundant Power Supplies



### Warning!

This unit might have more than one power supply connection. All connections must be removed to de-energize the unit.

### 冗長電源装置

このユニットは複数の電源装置が接続されている場合があります。  
ユニットの電源を切るためには、すべての接続を取り外さなければなりません。

### 警告

此部件连接的电源可能不止一个，必须将所有电源断开才能停止给该部件供电。

### 警告

此装置连接的电源可能不只一个，必须切断所有电源才能停止对该装置的供电。

### Warnung

Dieses Gerät kann mehr als eine Stromzufuhr haben. Um sicherzustellen, dass der Einheit kein Strom zugeführt wird, müssen alle Verbindungen entfernt werden.

### ¡Advertencia!

Puede que esta unidad tenga más de una conexión para fuentes de alimentación. Para cortar por completo el suministro de energía, deben desconectarse todas las conexiones.

### Attention

Cette unité peut avoir plus d'une connexion d'alimentation. Pour supprimer toute tension et tout courant électrique de l'unité, toutes les connexions d'alimentation doivent être débranchées.

**אם קיים יותר מספק אחד**

**אזהרה!**

ליחידה יש יותר מחיבור אחד של ספק. יש להסיר את כל החיבורים על מנת לרוקן את היחידה.

قد يكون لهذا الجهاز عدة اتصالات بوحدات امداد الطاقة.  
يجب إزالة كافة الاتصالات لعزل الوحدة عن الكهرباء

경고!

이 장치에는 한 개 이상의 전원 공급 단자가 연결되어 있을 수 있습니다. 이 장치에 전원을 차단하기 위해서는 모든 연결 단자를 제거해야만 합니다.

Waarschuwing

Deze eenheid kan meer dan één stroomtoevoeraansluiting bevatten. Alle aansluitingen dienen verwijderd te worden om het apparaat stroomloos te maken.

### Backplane Voltage



**Warning!**

Hazardous voltage or energy is present on the backplane when the system is operating. Use caution when servicing.

バックプレーンの電圧

システムの稼働中は危険な電圧または電力が、バックプレーン上にかかっています。

修理する際にはご注意ください。

警告

当系統正在进行时，背板上有很危险的电压或能量，进行维修时务必小心。

警告

當系統正在進行時，背板上有危險的電壓或能量，進行維修時務必小心。

Warnung

Wenn das System in Betrieb ist, treten auf der Rückwandplatine gefährliche Spannungen oder Energien auf. Vorsicht bei der Wartung.

¡Advertencia!

Cuando el sistema está en funcionamiento, el voltaje del plano trasero es peligroso. Tenga cuidado cuando lo revise.

Attention

Lorsque le système est en fonctionnement, des tensions électriques circulent sur le fond de panier. Prendre des précautions lors de la maintenance.

## מתח בפנל האחורי

אזהרה!  
קיימת סכנת מתח בפנל האחורי בזמן תפעול המערכת. יש להיזהר במהלך  
העבודה.

هناك خطر من التيار الكهربائي أو الطاقة الموجودة على اللوحة  
عندما يكون النظام يعمل كن حذرا عند خدمة هذا الجهاز

경고!

시스템이 동작 중일 때 후면판 (Backplane)에는 위험한 전압이나 에너지가 발생  
합니다. 서비스 작업 시 주의하십시오.

Waarschuwing

Een gevaarlijke spanning of energie is aanwezig op de backplane wanneer het  
systeem in gebruik is. Voorzichtigheid is geboden tijdens het onderhoud.

## Comply with Local and National Electrical Codes



### Warning!

Installation of the equipment must comply with local and national electrical codes.

地方および国の電気規格に準拠

機器の取り付けはその地方および国の電気規格に準拠する必要があります。

警告

设备安装必须符合本地与本国电气法规。

警告

設備安裝必須符合本地與本國電氣法規。

Warnung

Die Installation der Geräte muss den Sicherheitsstandards entsprechen.

¡Advertencia!

La instalación del equipo debe cumplir con las normas de electricidad locales y  
nacionales.

#### Attention

L'équipement doit être installé conformément aux normes électriques nationales et locales.

#### תיאום חוקי החשמל הארצי

אזהרה!

התקנת הציוד חייבת להיות תואמת לחוקי החשמל המקומיים והארציים.

تركيب المعدات الكهربائية يجب أن يمتثل للقوانين المحلية والوطنية المتعلقة بالكهرباء

경고!

현 지역 및 국가의 전기 규정에 따라 장비를 설치해야 합니다.

#### Waarschuwing

Bij installatie van de apparatuur moet worden voldaan aan de lokale en nationale elektriciteitsvoorschriften.

### Product Disposal



#### Warning!

Ultimate disposal of this product should be handled according to all national laws and regulations.

#### 製品の廃棄

この製品を廃棄処分する場合、国の関係する全ての法律・条例に従い処理する必要があります。

#### 警告

本产品的废弃处理应根据所有国家的法律和规章进行。

#### 警告

本產品的廢棄處理應根據所有國家的法律和規章進行。

#### Warnung

Die Entsorgung dieses Produkts sollte gemäß allen Bestimmungen und Gesetzen des Landes erfolgen.

¡Advertencia!

Al deshacerse por completo de este producto debe seguir todas las leyes y reglamentos nacionales.

Attention

La mise au rebut ou le recyclage de ce produit sont généralement soumis à des lois et/ou directives de respect de l'environnement. Renseignez-vous auprès de l'organisme compétent.

## סילוק המוצר

אזהרה!

סילוק סופי של מוצר זה חייב להיות בהתאם להנחיות וחוקי המדינה.

عند التخلص النهائي من هذا المنتج ينبغي التعامل معه وفقا لجميع القوانين واللوائح الوطنية

경고!

이 제품은 해당 국가의 관련 법규 및 규정에 따라 폐기되어야 합니다.

Waarschuwing

De uiteindelijke verwijdering van dit product dient te geschieden in overeenstemming met alle nationale wetten en reglementen.

## Hot Swap Fan Warning



### Warning!

The fans might still be turning when you remove the fan assembly from the chassis. Keep fingers, screwdrivers, and other objects away from the openings in the fan assembly's housing.

ファン・ホットスワップの警告

シャーシから冷却ファン装置を取り外した際、ファンがまだ回転している可能性があります。ファンの開口部に、指、ドライバー、およびその他のものを近づけないで下さい。

警告

当您从机架移除风扇装置，风扇可能仍在转动。小心不要将手指、螺丝起子和其他物品太靠近风扇

**警告**

當您從機架移除風扇裝置，風扇可能仍在轉動。小心不要將手指、螺絲起子和其他物品太靠近風扇。

**Warnung**

Die Lüfter drehen sich u. U. noch, wenn die Lüfterbaugruppe aus dem Chassis genommen wird. Halten Sie Finger, Schraubendreher und andere Gegenstände von den Öffnungen des Lüftergehäuses entfernt.

**¡Advertencia!**

Los ventiladores podran dar vuelta cuando usted quite el montaje del ventilador del chasis. Mantenga los dedos, los destornilladores y todos los objetos lejos de las aberturas del ventilador

**Attention**

Il est possible que les ventilateurs soient toujours en rotation lorsque vous retirez le bloc ventilateur du châssis. Prenez garde à ce que doigts, tournevis et autres objets soient éloignés du logement du bloc ventilateur.

**אזהרה!**

כאשר מסירים את חלקי המאוורר מהמארז, יתכן והמאווררים עדיין עובדים. יש להרחיק למרחק בטוח את האצבעות וכלי עבודה שונים מהפתחים בתוך המאוורר

من الممكن أن المراوح لا تزال تدور عند إزالة كتلة المروحة من الهيكل يجب إبقاء الأصابع ومفكات البراغي وغيرها من الأشياء بعيدا عن الفتحات في كتلة المروحة.

**경고!**

새시로부터 팬 조립품을 제거할 때 팬은 여전히 회전하고 있을 수 있습니다. 팬 조립품 외관의 열려있는 부분들로부터 손가락 및 스크류드라이버, 다른 물체들이 가까이 하지 않도록 배치해 주십시오.

**Waarschuwing**

Het is mogelijk dat de ventilator nog draait tijdens het verwijderen van het ventilatorsamenstel uit het chassis. Houd uw vingers, schroevendraaiers en eventuele andere voorwerpen uit de buurt van de openingen in de ventilatorbehuizing.

## Power Cable and AC Adapter



### Warning!

When installing the product, use the provided or designated connection cables, power cables and AC adaptors. Using any other cables and adaptors could cause a malfunction or a fire. Electrical Appliance and Material Safety Law prohibits the use of UL or CSA -certified cables (that have UL/CSA shown on the code) for any other electrical devices than products designated by Supermicro only.

#### 電源コードとACアダプター

製品を設置する場合、提供または指定された接続ケーブル、電源コードとACアダプターを使用下さい。他のケーブルやアダプタを使用すると故障や火災の原因になることがあります。電気用品安全法は、ULまたはCSA認定のケーブル(UL/CSEマークがコードに表記)をSupermicroが指定する製品以外に使用することを禁止しています。

#### 警告

安装此产品时,请使用本身提供的或指定的连接线,电源线和电源适配器.使用其它线材或适配器可能会引起故障或火灾.除了Supermicro所指定的产品,电气用品和材料安全法律规定禁止使用未经UL或CSA认证的线材。(线材上会显示UL/CSA符号)。

#### 警告

安装此產品時,請使用本身提供的或指定的連接線,電源線和電源適配器.使用其它線材或適配器可能會引起故障或火災.除了Supermicro所指定的產品,電氣用品和材料安全法律規定禁止使用未經UL或CSA認證的線材。(線材上會顯示UL/CSA符號)。

#### Warnung

Bei der Installation des Produkts, die zur Verfügung gestellten oder benannt Anschlusskabel, Stromkabel und Netzteile. Verwendung anderer Kabel und Adapter kann zu einer Fehlfunktion oder ein Brand entstehen. Elektrische Geräte und Material Safety Law verbietet die Verwendung von UL-oder CSA-zertifizierte Kabel, UL oder CSA auf der Code für alle anderen elektrischen Geräte als Produkte von Supermicro nur bezeichnet gezeigt haben.

#### ¡Advertencia!

Al instalar el producto, utilice los cables de conexión previstos o designados, los cables y adaptadores de CA. La utilización de otros cables y adaptadores podría ocasionar un mal funcionamiento o un incendio. Aparatos Eléctricos y la Ley de Seguridad del Material prohíbe el uso de UL o CSA cables certificados que tienen UL o CSA se muestra en el código de otros dispositivos eléctricos que los productos designados por Supermicro solamente.



## Attention

Lors de l'installation du produit, utilisez les bables de connection fournis ou désigné. L'utilisation d'autres cables et adaptateurs peut provoquer un dysfonctionnement ou un incendie. Appareils électroménagers et de loi sur la sécurité Matériel interdit l'utilisation de UL ou CSA cables certifiés qui ont UL ou CSA indiqué sur le code pour tous les autres appareils électriques que les produits désignés par Supermicro seulement.

## חשמליים ומתאמי AC

## אזהרה!

כאשר מתקינים את המוצר, יש להשתמש בכבלים, ספקים ומתאמים AC אשר נועדו וסופקו לשם כך. שימוש בכל כבל או מתאם אחר יכול לגרום לתקלה או קצר חשמלי. על פי חוקי שימוש במכשירי חשמל וחוקי בטיחות, קיים איסור להשתמש בכבלים המוסמכים ב- UL או ב- CSA (כשאר מופיע עליהם קוד של UL/CSA) עבור כל מוצר חשמלי אחר שלא צוין על ידי סופרמיקרו בלבד.

عند تركيب الجهاز يجب استخدام كابلات التوصيل، والكابلات الكهربائية ومحولات التيار المتردد التي . أن استخدام أي كابلات ومحولات أخرى يتسبب في حدوث عطل أو حريق. تم توفيرها لك مع المنتج الأجهزة الكهربائية ومواد قانون السلامة يحظر استخدام الكابلات CSA أو UL معتمدة من قبل لأي أجهزة كهربائية أخرى غير المنتجات المعينة من قبل Supermicro (التي تحمل علامة UL/CSA)

## 경고!

제품을 설치할 때에는 제공되거나 지정된 연결케이블과 전원케이블, AC 어댑터를 사용해야 합니다. 그 밖의 다른 케이블들이나 어댑터들은 고장 또는 화재의 원인이 될 수 있습니다. 전기용품안전법 (Electrical Appliance and Material Safety Law)은 슈퍼마이크로에서 지정한 제품들 외에는 그 밖의 다른 전기 장치들을 위한 UL 또는 CSA에서 인증한 케이블(전선 위에 UL/CSA가 표시)들의 사용을 금지합니다.

## Waarschuwing

Bij het installeren van het product, gebruik de meegeleverde of aangewezen kabels, stroomkabels en adapters. Het gebruik van andere kabels en adapters kan leiden tot een storing of een brand. Elektrisch apparaat en veiligheidsinformatiebladen wet verbiedt het gebruik van UL of CSA gecertificeerde kabels die UL of CSA die op de code voor andere elektrische apparaten dan de producten die door Supermicro alleen.

## Notes

## Chapter 5

# Advanced Motherboard Setup

This chapter covers the steps required to install the A1SAM-2550F motherboard into the SC813MFTQ-202CB chassis, connect the data and power cables and install add-on cards. All motherboard jumpers and connections are also described. A layout and quick reference chart are included in this chapter for your reference. Remember to completely close the chassis when you have finished working with the motherboard to better cool and protect the system.

### 5-1 Handling the Motherboard

Electrostatic Discharge (ESD) can damage electronic components. To prevent damage to any printed circuit boards (PCBs), it is important to handle them very carefully (see previous chapter). To prevent the A1SAM-2550F motherboard from bending, keep one hand under the center of the board to support it when handling. The following measures are generally sufficient to protect your equipment from electric static discharge.

#### Precautions

- Use a grounded wrist strap designed to prevent Electrostatic Discharge (ESD).
- Touch a grounded metal object before removing any board from its antistatic bag.
- Handle a board by its edges only; do not touch its components, peripheral chips, memory modules or gold contacts.
- When handling chips or modules, avoid touching their pins.
- Put the motherboard, add-on cards and peripherals back into their antistatic bags when not in use.
- For grounding purposes, make sure your computer chassis provides excellent conductivity between the power supply, the case, the mounting fasteners and the motherboard.

## Unpacking

The motherboard is shipped in antistatic packaging to avoid electrical static discharge. When unpacking the board, make sure the person handling it is static protected.

## 5-2 Motherboard Installation

This section explains the first step of physically mounting the A1SAM-2550F into the SC813MFTQ-202CB chassis. Following the steps in the order given will eliminate the most common problems encountered in such an installation. To remove the motherboard, follow the procedure in reverse order.

### *Installing to the Chassis*

1. Remove the screws from the rear lip of the chassis cover (see Figure 2-5).
2. Release the top cover by pushing it away from you until it stops. You can then lift the top cover from the chassis to gain full access to the inside of the server
3. Make sure that the I/O ports on the motherboard align properly with their respective holes in the I/O shield at the back of the chassis.
4. Carefully mount the motherboard to the motherboard tray by aligning the board holes with the raised metal standoffs that are visible in the chassis.
5. Insert screws into all the mounting holes on your motherboard that line up with the standoffs and tighten until snug (if you screw them in too tight, you might strip the threads).

**Note:** Metal screws provide an electrical contact to the motherboard ground to provide a continuous ground for the system.

**Warning:** To avoid damaging the motherboard and its components, do not apply any force greater than 8 lbs. per square inch when installing a screw into a mounting hole.

## 5-3 Connecting Cables

Now that the motherboard is installed, the next step is to connect the cables to the board. These include the data cables for the peripherals and control panel and the power cables.

### Connecting Data Cables

The cables used to transfer data from the peripheral devices have been carefully routed to prevent them from blocking the flow of cooling air that moves through the system from front to back. If you need to disconnect any of these cables, you should take care to keep them routed as they were originally after reconnecting them.

The following data cables (with their locations noted) must remain connected. (See the layout on page 5-12 for connector locations.)

- SATA drive cables (I-SATA0 ~ I-SATA3)
- Control Panel cable (JF1)

### Connecting Power Cables

The A1SAM-2550F has a 24-pin primary power supply connector (JPW1) for connection to the ATX power supply. See Section 5-9 for power connector pin definitions.

### Connecting the Control Panel

JF1 contains header pins for various front control panel connectors. See Figure 5-1 for the pin locations of the various front control panel buttons and LED indicators.

All JF1 wires have been bundled into a single ribbon cable to simplify this connection. Make sure the red wire plugs into pin 1 as marked on the board. The other end connects to the Control Panel PCB board, located just behind the system status LEDs on the chassis.

Figure 5-1. Control Panel Header Pins

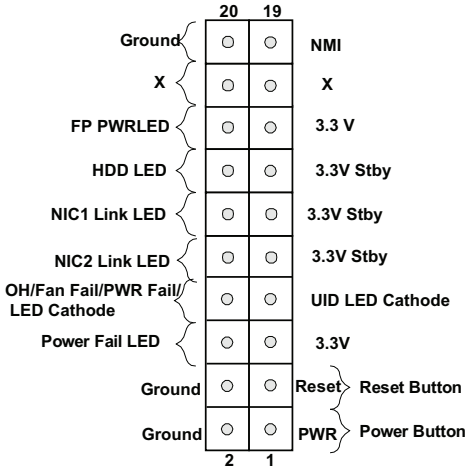

### 5-4 Rear I/O Ports

The I/O ports are located on the backplane of the motherboard. See Figure 5-2 below for the descriptions of the various I/O ports.

Figure 5-2. Rear I/O Ports

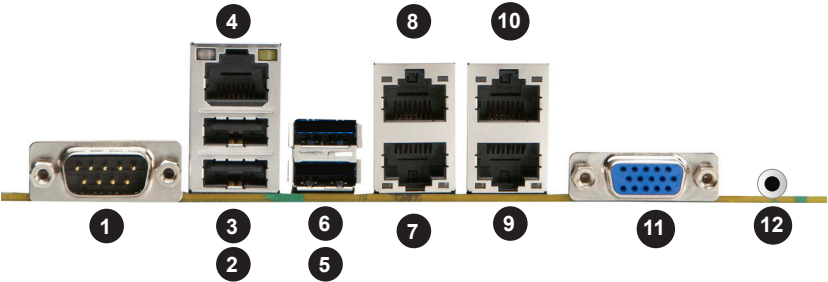

Rear I/O Ports	
1. COM1 Port	7. LAN1 Port
2. USB0 (USB 2.0)	8. LAN3 Port
3. USB1 (USB 2.0)	9. LAN2 Port
4. Dedicated IPMI LAN	10. LAN4 Port
5. USB2 (USB 2.0)	11. VGA Port
6. USB3 (USB 2.0)	12. UID Button

## 5-5 Onboard Processor and Heatsink

The A1SRI-2758F features an embedded Intel® C2000 Tri-Gate 22nm SoC (System-on-a Chip) Series processor and attached heatsink.

## 5-6 Installing Memory Modules

**Note:** Check the Supermicro web site for recommended memory modules.

### CAUTION

Exercise extreme care when installing or removing DIMMs to prevent any possible damage.

### Installing & Removing DIMMs

1. Insert the desired number of DIMMs into the memory slots in the following order: DIMMA1, then DIMMB1, then DIMMA2, then DIMMB2. For best performance, please use DIMMs of the same type and same speed. See the DIMM installation charts on the following pages.
2. Push back the release tabs on the ends of a memory slot. Insert each DIMM vertically into its slot, paying attention to the notch along the bottom of the DIMM to prevent inserting it incorrectly.
3. Gently press down on the DIMM until it snaps into place in the slot. Repeat for all modules.
4. Reverse the steps above to remove a DIMM from the motherboard.

Figure 5-3. DIMM Installation

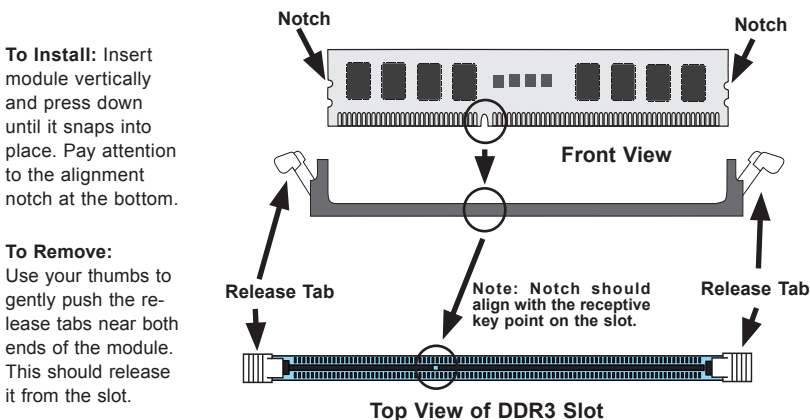

### Memory Support

The A1SAM-2550F motherboard supports up to 64GB of DDR3-1600/1333 Unbuffered (UDIMM) ECC/Non-ECC memory. For the latest memory updates, please refer to the Supermicro website.

### Memory Population Guidelines

Please follow the table below when populating the DIMM slots.

Unbuffered (UDIMM) DDR3 Memory				
DIMM Slots per Channel	DIMMs per Channel	DIMM Type	POR Speeds	Memory Population Sequence
2	1	Unbuffered DDR3 DIMM	1600,1333	A1, B1 (2 DIMMs)
2	2	Unbuffered DDR3 DIMM	1600,1333	A1, B1, A2, B2 (4 DIMMs)

**Note:** Use memory modules of the same type, speed, frequency and size.

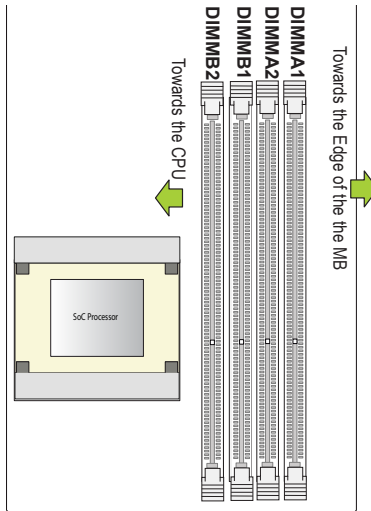



**Note:** Due to memory allocation to system devices, the amount of memory that remains available for operational use will be reduced when 4 GB of RAM is used. The reduction in memory availability is disproportional. See the following table for details.

<b>Possible System Memory Allocation &amp; Availability</b>		
<b>System Device</b>	<b>Size</b>	<b>Physical Memory Remaining (Available) (4 GB Total System Memory)</b>
Firmware Hub flash memory (System BIOS)	1 MB	3.99
Local APIC	4 KB	3.99
Area Reserved for the chipset	2 MB	3.99
I/O APIC (4 Kbytes)	4 KB	3.99
PCI Enumeration Area 1	256 MB	3.76
PCI Express (256 MB)	256 MB	3.51
PCI Enumeration Area 2 (if needed) -Aligned on 256-MB boundary-	512 MB	3.01
VGA Memory	16 MB	2.85
TSEG	1 MB	2.84
Memory available to OS and other applications		2.84

## 5-7 Adding PCI Cards

With the optional RSC-RR1U-E8 riser card installed into a PCI-E slot, the 5018A-MLTN4 can support a full-height half-length PCI Express expansion card. Refer to Chapter 6 Section 7 for details.

## 5-8 Motherboard Details

### Motherboard Layout

Figure 5-5. A1SAM-2550F Layout

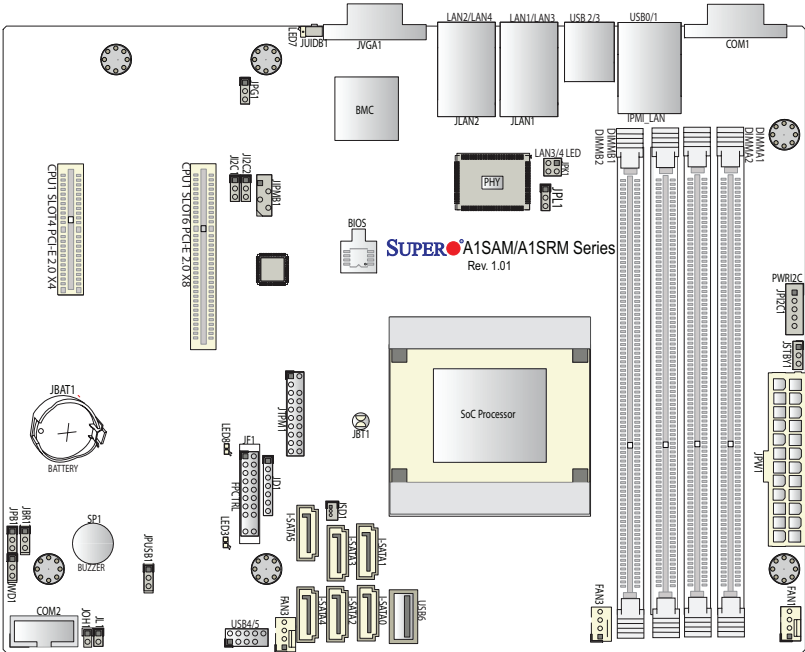

**Note:** Jumpers not noted are for test purposes only.

#### A1SAM-2550F Quick Reference Table

LED	Description	State/Status
LED3	Power LED	Green: System Power On
LED7	UID Switch LED	Blue: On Unit Identified
LED8	Overheat/PWR/Fan Fail LED	Solid On: Overheat Blinking: Power Fail or Fan Fail

Jumper	Description	Default
JBR1	BIOS Recovery Enable/Disable	Pins 1-2 (Normal)
JBT1	CMOS Clear	Off (Normal)
JI <sup>2</sup> C1/JI <sup>2</sup> C2	SMB to PCI-Exp. Slots	Off (Disabled)
JPB1	BMC Enable/Disable	Pins 1-2 (Enabled)
JPG1	VGA Enable/Disable	Pins 1-2 (Enabled)
JPL1	LAN Ports Enable/Disable	Pins 1-2 (Enabled)
JUSB1	USB Wake Enable/Disable	Pins 1-2 (Enabled)
JWD1	Watch Dog	Pins 1-2 (Reset)

Connector	Description
Battery	Onboard Battery (JBAT1)
COM1/COM2	COM1/COM2 Port Headers
FAN1-FAN3	System Cooling Fans
JD1	Power LED/Speaker Header
JF1	Front Panel Control Header
JIPMB1	4-pin External SMBus I <sup>2</sup> C Header
JL1	Chassis Intrusion Header
JOH1	Overheat LED Header
JPI <sup>2</sup> C1	Power Supply System Management Bus (SMBus) I <sup>2</sup> C Header
JPK1	LAN3/LAN4 LED Indication Header
JPW1	24-pin ATX Power Connector
JSD1	SATA DOM (Device On Module) Power Connector
JSTBY1	5V Standby Power Connector
JTPM1	Trusted Platform Module (TPM)/Port 80 Connector
JUIDB1	Unit Identifier (UID) Switch
LAN1/3, LAN2/4	Gigabit Ethernet (RJ45) Ports 1/3, 2/4
IPMI-LAN	Dedicated IPMI LAN for IPMI 2.0 Interface
I-SATA0-I-SATA5	(Intel) Serial ATA Ports 0-5
(CPU1) Slot4	PCI-E 2.0 x4 slot
(CPU1) Slot6	PCI-E 2.0 x8 slot
SP1	Internal Speaker/Buzzer
USB 0/1, 2/3	Backpanel USB 2.0 Ports 0/1, 2/3
USB 4/5	Front Panel Accessible USB 2.0 Headers

## 5-9 Connector Definitions

### ATX Power Connector

The 24-pin ATX power supply connector (JPW1) provides power to the motherboard. See the table on the right for pin definitions.

ATX Power 24-pin Connector Pin Definitions			
Pin#	Definition	Pin #	Definition
13	+3.3V	1	+3.3V
14	-12V	2	+3.3V
15	COM	3	COM
16	PS_ON	4	+5V
17	COM	5	COM
18	COM	6	+5V
19	COM	7	COM
20	Res (NC)	8	PWR_OK
21	+5V	9	5VSB
22	+5V	10	+12V
23	+5V	11	+12V
24	COM	12	+3.3V

### Power Button

The Power Button connection is on pins 1 and 2 of JF1. This header should be connected to the chassis power button. See the table on the right for pin definitions.

Power Button Pin Definitions	
Pin#	Definition
1	Signal
2	+3V Standby

### Reset Button

The Reset Button connection is located on pins 3 and 4 of JF1 and attaches to the reset switch on the computer chassis. See the table on the right for pin definitions.

Reset Button Pin Definitions	
Pin#	Definition
3	Reset
4	Ground

### Power Fail LED

The Power Fail LED connection is located on pins 5 and 6 of JF1. Refer to the table on the right for pin definitions.

PWR Fail LED Pin Definitions	
Pin#	Definition
5	3.3V
6	Signal

### Overheat (OH)/Fan Fail/PWR Fail/UID LED

Connect an LED cable to pins 7 and 8 of Front Control Panel to use the Overheat/Fan Fail/Power Fail and UID LED connections. The Red LED on pin 7 provides warnings of overheat, fan failure or power failure. The Blue LED on pin 8 works as the front panel UID LED indicator. The Red LED takes precedence over the Blue LED by default. Refer to the table on the right for pin definitions.

OH/Fan Fail/ PWR Fail/Blue_UID LED Pin Definitions	
Pin#	Definition
7	Blue_UID LED
8	OH/Fan Fail/Power Fail Cathode

### NIC2 (LAN2) LED

The LED connections for LAN2 are on pins 9 and 10 of JF1. Attach LAN LED cables to display network activity. See the table on the right for pin definitions.

LAN1/LAN2 LED Pin Definitions	
Pin#	Definition
9/11	3.3V Standby
10/12	NIC Link LED

### HDD LED

The HDD LED connection is located on pins 13 and 14 of JF1. Attach the hard drive LED cable here to display disk activity (for any hard drives on the system). See the table on the right for pin definitions.

HDD LED Pin Definitions	
Pin#	Definition
13	3.3V Standby
14	HDD Active

### Power On LED

The Power On LED connector is located on pins 15 and 16 of JF1. This connection is used to provide LED indication of power being supplied to the system. See the table on the right for pin definitions.

Power LED Pin Definitions	
Pin#	Definition
15	3.3V
16	Power LED

## NMI Button

The non-maskable interrupt button header is located on pins 19 and 20 of JF1. Refer to the table on the right for pin definitions.

NMI Button Pin Definitions	
Pin#	Definition
19	Control
20	Ground

## Fan Headers

There are three fan headers on the A1SAM-2550F. All are 4-pin fans but are backward compatible with traditional 3-pin fans. Fan speed control, however, is available for 4-pin fans only (via BMC). See the table on the right for pin definitions.

Fan Header Pin Definitions	
Pin#	Definition
1	Ground (Black)
2	2.5A/+12V (Red)
3	Tachometer
4	PWM Control

**Note:** the fans on the A1SAM-2550F are not hot-swappable.

## Chassis Intrusion

The Chassis Intrusion header is designated JL1. See the board layout for the location of JL1 and the table on the right for pin definitions.

Chassis Intrusion Pin Definitions	
Pin#	Definition
1	Intrusion Input
2	Ground

## Universal Serial Bus (USB)

There are four Universal Serial Bus ports located on the I/O backpanel (USB01/, USB2/3) and an additional header located on the motherboard. The header, labeled USB4/5, as well as USB 6, a Type A port, can be used to provide front side USB access (cables not included). See the tables on the right for pin definitions.

Back Panel USB0/1, 2/3 Pin Definitions			
Pin #	Definition	Pin #	Definition
1	+5V	1	+5V
2	USB_PN1	2	USB_PN0
3	USB_PP1	3	USB_PP0
4	Ground	5	Ground

USB Headers Pin Definitions (USB0/1, USB4)			
USB4/6		USB5	
Pin #	Definition	Pin #	Definition
1	+5V	1	+5V
2	PO-	2	PO-
3	PO+	3	PO+
4	Ground	4	Ground
5	No connection	5	Key

## Serial Ports

Two serial ports are included on the motherboard: COM1 is located on the I/O backpanel and COM2 is a header (located near the onboard buzzer) for front access support. See the table on the right for pin definitions.

Serial Port Pin Definitions			
Pin #	Definition	Pin #	Definition
1	DCD	6	DSR
2	RXD	7	RTS
3	TXD	8	CTS
4	DTR	9	RI
5	Ground	10	NC

**Note:** Pin 10 is included on the header but not on the port. NC indicates no connection.

## Power SMB (I<sup>2</sup>C) Connector

Power System Management Bus (I<sup>2</sup>C) Connector (JPI<sup>2</sup>C1) monitors power supply, fan and system temperatures. See the table on the right for pin definitions.

PWR SMB Pin Definitions	
Pin#	Definition
1	Clock
2	Data
3	PWR Fail
4	Ground
5	+3.3V

## Onboard Speaker (SP1)

The onboard speaker provides audible indications for various beep codes. See the table on the right for pin definitions.

Internal Buzzer Pin Definition		
Pin#	Definitions	
Pin 1	Pos. (+)	Beep In
Pin 2	Neg. (-)	Alarm Speaker

## Power LED/Speaker

On JD1 header, pins 1-3 are used for power LED indication, and pins 4-7 are for the speaker. Connect pins (4-7) of JD1 with a cable to use the external speaker. If you wish to use the onboard speaker, close pins 6-7 with a jumper (Default). See the tables on the right for pin definitions.

PWR LED Connector Pin Definitions	
Pin Setting	Definition
Pin 1	Anode (+)
Pin2	Cathode (-)
Pin3	NA

Speaker Connector Pin Settings	
Pin Setting	Definition
Pins 4-7	External Speaker
Pins 6-7	Internal Speaker (Default)

### DOM Power Connector

A power connector for SATA DOM (Disk On Module) devices is located at JSD1. Connect an appropriate cable here to provide power support for your Serial Link DOM devices.

DOM PWR Pin Definitions	
Pin#	Definition
1	+5V
2	Ground
3	Ground

### TPM/Port 80 Header

A Trusted Platform Module/Port 80 header is located at JTPM1 to provide TPM support and Port 80 connection. Use this header to enhance system performance and data security. See the table on the right for pin definitions.

TPM/Port 80 Header Pin Definitions			
Pin #	Definition	Pin #	Definition
1	LCLK	2	GND
3	LFRAME#	4	<(KEY)>
5	LRESET#	6	+5V (X)
7	LAD 3	8	LAD 2
9	+3.3V	10	LAD1
11	LAD0	12	GND
13	SMB_CLK4	14	SMB_DAT4
15	+3V_DUAL	16	SERIRQ
17	GND	18	CLKRUN# (X)
19	LPCPD#	20	LDRQ# (X)

### Overheat LED/Fan Fail

The JOH1 header is used to connect an LED indicator to provide warnings of chassis overheating and fan failure. This LED will blink when a fan failure occurs. Refer to the tables on right for pin definitions.

Overheat LED Pin Definitions	
Pin#	Definition
1	5vDC
2	OH Active

OH/Fan Fail/PWR Fail LED Status (Red LED)	
State	Message
Off	Normal
Solid	Overheat
Blinking	Fan Fail

### LAN3/LAN4 LED Indication Header

Connect an appropriate cable to the LAN3/4 LED indication header located at JPK1 to indicate activity on the LAN3/4 ports. (LAN1/LAN2 LED indicator connections are located on JF1.)



### LAN (Ethernet) Ports

Four Gigabit Ethernet ports (LAN1/2/3/4) are provided on the motherboard. These ports accept RJ45 type cables. The A1SAM-2550F also includes a dedicated IPMI LAN port above the rear USB ports to provide KVM support for IPMI 2.0.

LAN Port Pin Definitions			
Pin#	Definition	Pin#	Definition
1	P2V5SB	10	SGND
2	TD0+	11	Act LED
3	TD0-	12	P3V3SB
4	TD1+	13	Link 100 LED (Yellow, +3V3SB)
5	TD1-	14	Link 1000 LED (Yellow, +3V3SB)
6	TD2+	15	Ground
7	TD2-	16	Ground
8	TD3+	17	Ground
9	TD3-	18	Ground

### Unit Identifier Switch/UID LED Indicators

A Unit Identifier button (JUIDB), a backplane LED indicator and a front panel UID header are provided on the motherboard. The UID button is located next to the VGA port on the backplane. The UID LED indicator (LED1) is located next to the UID button. The front panel UID LED header is located at pins 7/8 of JF1. Connect a cable to pin 8 on JF1 for the front panel UID LED connection. When you press the UID button, both the rear UID LED and the front panel UID LED will turn on. Press the UID button again to turn off both LEDs. These UID indicators provide easy identification of a system that may be in need of service.

**Note:** UID can also be triggered via IPMI on the motherboard. For more information on IPMI, please refer to the IPMI User's Guide posted on our website: <http://www.supermicro.com>.

UID Button	
Pin#	Definition
1	Ground
2	Ground
3	Ground
4	Button In

UID LED Status		
Color/State	OS	Status
Blue: On	Windows OS	Unit Identified
Blue: Blinking	Linux OS	Unit Identified

### System Management Bus Header

A System Management Bus header for IPMI 2.0 is located at JIPMIB1. Connect the appropriate cable here to use the IPMI I<sup>2</sup>C connection on your system.

SMBus Header Pin Definitions	
Pin#	Definition
1	Data
2	Ground
3	Clock
4	No Connection

### Standby Power

The 5V Standby Power header is located at JSTBY1 on the motherboard.

Standby Power Pin Definitions	
Pin#	Definition
1	+5V Standby
2	Ground
3	Wake-up

### Overheat LED Header

The JOH1 header is used to connect an LED indicator to provide warnings of chassis overheating and fan failure. This LED will blink when a fan failure occurs. Refer to the tables on right for pin definitions.

Overheat LED Pin Definitions	
Pin	Definition
1	5vDC
2	OH Active

OH/Fan Fail/PWR Fail LED Status (Red LED)	
State	Definition
Off	Normal
Solid	Overheat
Flashing	Fan Fail

## 5-10 Jumper Settings

### Explanation of Jumpers

To modify the operation of the motherboard, jumpers can be used to choose between optional settings. Jumpers create shorts between two pins to change the function of the connector. Pin 1 is identified with a square solder pad on the printed circuit board. See the motherboard layout pages for jumper locations.

**Note:** On a two-pin jumper, "Closed" means the jumper is on both pins and "Open" means the jumper is either on only one pin or completely removed.

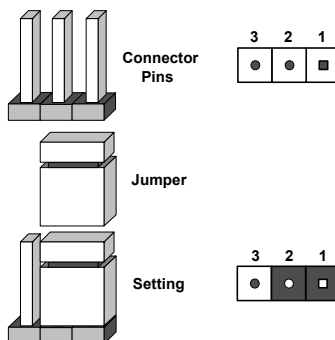

### CMOS Clear

JBT1 is used to clear CMOS (which will also clear any passwords). Instead of pins, this jumper consists of contact pads to prevent accidentally clearing the contents of CMOS. To clear CMOS,

1. First power down the system and unplug the power cord(s).
2. With the power disconnected, short the CMOS pads with a metal object such as a small screwdriver.
3. Remove the screwdriver (or shorting device).
4. Reconnect the power cord(s) and power on the system

**Note:** Do not use the PW\_ON connector to clear CMOS.

### LAN1/LAN2 Enable/Disable

Change the setting of jumper JPL1 to enable or disable LAN ports on the motherboard. See the table on the right for jumper settings. The default setting is enabled.

LAN1/2 Enable/Disable Jumper Settings	
Jumper Setting	Definition
Pins 1-2	Enabled
Pins 2-3	Disabled

### VGA Enable/Disable

JPG1 allows you to enable or disable the VGA port. The default position is on pins 1 and 2 to enable VGA. See the table on the right for jumper settings.

VGA Enable/Disable Jumper Settings	
Jumper Setting	Definition
Pins 1-2	Enabled
Pins 2-3	Disabled

### Watch Dog

JWD1 enables the Watch Dog function, a system monitor that takes action when a software application freezes the system. Jumping pins 1-2 will have WD reboot the system if a program freezes. Jumping pins 2-3 will generate a non-maskable interrupt for the program that has frozen. See the table on the right for jumper settings. Watch Dog must also be enabled in BIOS.

Watch Dog Jumper Settings	
Jumper Setting	Definition
Pins 1-2	Reset
Pins 2-3	NMI
Open	Disabled

**Note:** when Watch Dog is enabled, the user must write their own application software to disable the Watch Dog Timer.

### BMC Enable

Jumper JPB1 allows you to enable the embedded BMC (Baseboard Management Controller) to provide IPMI 2.0 support. See the table on the right for jumper settings. The default setting is enabled.

BMC Enable Jumper Settings	
Jumper Setting	Definition
Pins 1-2	BMC Enabled
Pins 2-3	Disabled

### PCI-E Slot SMB Enable

Use jumpers I<sup>2</sup>C1/I<sup>2</sup>C2 to enable PCI SMB (System Management Bus) support to improve system management for the onboard PCI-E slots. The default setting is disabled. See the table on the right for jumper settings.

PCI Slot_SMB Enable Jumper Settings	
Jumper Setting	Definition
Closed	Enabled
Open (Default)	Disabled

### BIOS Recovery Enable

Close pins 1 and 2 of jumper JBR1 for BIOS recovery. The default setting is on pins 1 and 2 for normal operation. See the table on the right for jumper settings.

BIOS Recovery Enable Jumper Settings	
Jumper Setting	Definition
Pins 1-2	Normal
Pins 2-3	BIOS Recovery

### USB Wake-Up Enable

Close pins 1/2 of jumper JPUSB1 to "wake-up" the system by pressing a key on the USB keyboard or by clicking the USB mouse connected front accessible USB 4/5 or USB6. JPUSB1 is in conjunction with the USB Wake-Up function in the BIOS. Enable both the jumper and the BIOS setting to enable this function. Default setting is Normal.

USB Wake_UP Enable Jumper Settings	
Jumper Setting	Definition
Pins 1-2	USB Wake_up Enable
Pins 2-3	Normal

## 5-11 Onboard Indicators

### LAN Port LEDs

The Ethernet ports each have two LEDs. The yellow LED indicates activity when blinking while the other LED may be green, amber or off to indicate the speed of the connection. See the table on the right for the functions associated with the connection speed LED.



LAN LED (Connection Speed Indicator)	
LED Color	Definition
Off	No Connection or 10 Mb/s
Green	10 Gb/s
Amber	1 Gb/s

### IPMI Dedicated LAN LEDs

The IPMI LAN port has two LEDs as well. The amber LED on the right indicates activity, while the green LED on the left indicates the speed of the connection. See the table at right for more information.

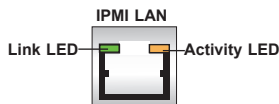

IPMI LAN Link LED (Left) & Activity LED (Right)		
LED	Color/State	Definition
Link (Left)	Green: Solid	100 Mbps
Activity (Right)	Amber: Blinking	Active

### Onboard Power LED

An Onboard Power LED is located at LED3 on the motherboard. When this LED is on, the system is on. Be sure to turn off the system and unplug the power cord before removing or installing components. See the table at right for more information.

Onboard PWR LED Indicator LED States	
LED Color	Definition
Off	System Off (PWR cable not connected)
Green	System On
Green: Flashing Quickly	ACPI S1 State

### Overheat/PWR Fail/Fan Fail LED

An onboard Overheat/Power Failure/Fan Failure LED is located at LED8. See the table on the right for more information.

Overheat/PWR Fail/Fan Fail LED Settings	
Color/State	Definition
Solid	Overheat
Blinking	PWR Fail or Fan Fail

### Unit Identification LED

A rear UID LED indicator (LED7) is located next to the Unit Identifier (UID) button on the I/O backplane. The front panel UID LED is located at pin 7 of the Front Control Panel at JF1. Connect a cable to pin 7 on JF1 for front panel UID LED indication. When you press the UID button, both the rear UID LED and the front panel UID LED indicators will be turned on. Press the UID button again to turn off both LED indicators. These LEDs provide easy identification of a system unit that may be in need of service.

UID LED Status		
Color/State	OS	Status
Blue: On	Windows OS	Unit Identified
Blue: Blinking	Linux OS	Unit Identified

**Note:** UID can also be triggered via IPMI on the motherboard. For more information on IPMI, please refer to the IPMI User's Guide posted on our Website at <http://www.supermicro.com>.

## 5-12 SATA Ports

### SATA Ports

Six SATA ports are included on the motherboard. I-SATA 0/1 are SATA 3.0 ports and I-SATA2-I-SATA5 are SATA 2.0 ports. See the table on the right for pin definitions.

SATA Port Pin Definitions	
Pin #	Definition
1	Ground
2	TXP
3	TXN
4	Ground
5	RXN
6	RXP
7	Ground

## 5-13 Installing Software

The Supermicro ftp site contains drivers and utilities for your system at <ftp://ftp.supermicro.com>. Some of these must be installed, such as the chipset driver.

After accessing the ftp site, go into the CDR\_Images directory and locate the ISO file for your motherboard. Download this file to create a CD/DVD of the drivers and utilities it contains. (You may also use a utility to extract the ISO file if preferred.)

Another option is to go to the Supermicro Website at <http://www.supermicro.com/products/>. Find the product page for your motherboard here, where you may download individual drivers and utilities.

After creating a CD/DVD with the ISO files, insert the disk into the CD/DVD drive on your system and the display shown in Figure 5-6 should appear.

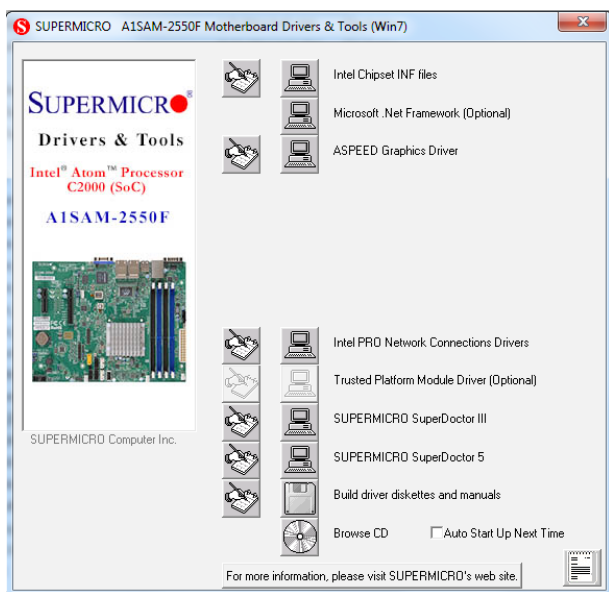

Figure 5-6. Driver/Tool Installation Display Screen

**Note:** Click the icons showing a hand writing on paper to view the readme files for each item. Click the computer icons to the right of these items to install each item (from top to the bottom) one at a time. **After installing each item, you must re-boot the system before moving on to the next item on the list.** The bottom icon with a CD on it allows you to view the entire contents.



## SuperDoctor® 5

The Supermicro SuperDoctor 5 is a program that functions in a command-line or web-based interface in Windows and Linux operating systems. The program monitors system health information such as CPU temperature, system voltages, system power consumption, fan speed, and provides alerts via email or Simple Network Management Protocol (SNMP).

SuperDoctor 5 comes in local and remote management versions and can be used with Nagios to maximize your system monitoring needs. With SuperDoctor 5 Management Server (SSM Server), you can remotely control power on/off and reset chassis intrusion for multiple systems with SuperDoctor 5 or IPMI. SD5 Management Server monitors HTTP, FTP, and SMTP services to optimize the efficiency of your operation.

**Note:** The default User Name and Password for SuperDoctor 5 is admin / admin.

**Figure 5-7. SuperDoctor 5 Interface Display Screen (Health Information)**



**Note:** The SuperDoctor 5 program and User's Manual can be downloaded from the Supermicro web site at [http://www.supermicro.com/products/nfo/sms\\_sd5.cfm](http://www.supermicro.com/products/nfo/sms_sd5.cfm).

## 5-14 Onboard Battery

Please handle used batteries carefully. Do not damage the battery in any way; a damaged battery may release hazardous materials into the environment. Do not discard a used battery in the garbage or a public landfill. Please comply with the regulations set up by your local hazardous waste management agency to dispose of your used battery properly.

**Figure 5-8. Installing the Onboard Battery**

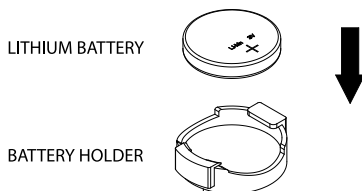

## Chapter 6

### Advanced Chassis Setup

This chapter covers the steps required to install components and perform maintenance on the SC512L-200B chassis. For component installation, follow the steps in the order given to eliminate the most common problems encountered. If some steps are unnecessary, skip ahead to the step that follows.

**Tools Required:** The only tool you will need to install components and perform maintenance is a Philips screwdriver.

#### 6-1 Static-Sensitive Devices

Electrostatic Discharge (ESD) can damage electronic components. To prevent damage to any printed circuit boards (PCBs), it is important to handle them very carefully. The following measures are generally sufficient to protect your equipment from ESD discharge.

##### Precautions

- Use a grounded wrist strap designed to prevent static discharge.
- Touch a grounded metal object before removing any board from its antistatic bag.
- Handle a board by its edges only; do not touch its components, peripheral chips, memory modules or gold contacts.
- When handling chips or modules, avoid touching their pins.
- Put the motherboard, add-on cards and peripherals back into their antistatic bags when not in use.
- For grounding purposes, make sure your computer chassis provides excellent conductivity between the power supply, the case, the mounting fasteners and the motherboard.

##### Unpacking

The motherboard is shipped in antistatic packaging to avoid static damage. When unpacking the board, make sure the person handling it is static protected.

**Figure 6-1. Chassis Front View**

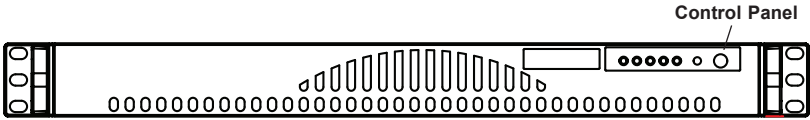

**Figure 6-2. Chassis Rear View**



Power Supply

I/O Ports

## 6-2 Control Panel

The control panel (located on the front of the chassis) must be connected to the JF1 connector on the motherboard to provide you with system control buttons and status indicators. These wires have been bundled together in a ribbon cable to simplify the connection.

The LEDs inform you of system status. See Chapter 3 for details on the LEDs and the control panel buttons. Details on JF1 can be found in Chapter 5.

## 6-3 Removing the Chassis Cover

### *Removing the Chassis Cover*

1. Power down the system and disconnect the power cord from the from the rear of the power supply.
2. Place the chassis on a stable hard surface.
3. Remove the screws holding the chassis cover in place.
4. Apply pressure to the middle front of the chassis cover.
5. Slide the cover toward the rear of the chassis.

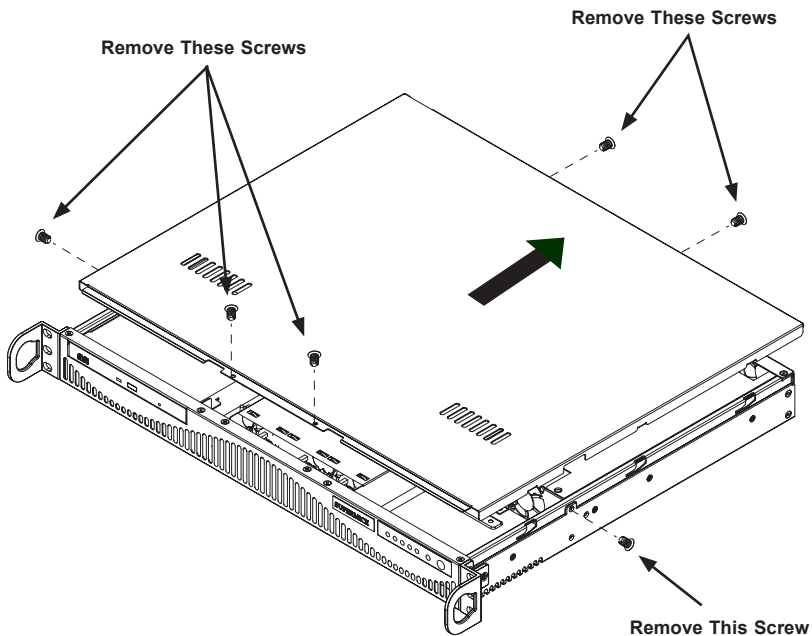

Figure 6-3. Removing the Chassis Cover

**Warning:** Except for short periods of time, do NOT operate the server without the cover in place. The chassis cover must be in place to allow proper airflow and prevent overheating.

## 6-4 System Fan

A single 10-cm blower fan provides sufficient cooling for the SuperServer 5018A-MLTN4.

The fan can adjust its speed according to the heat level sensed in the system, which results in more efficient and quieter fan operation. Fan speed is controlled by IPMI.

### ***Replacing the Blower Fan***

1. Power down the system and disconnect the power cord from the from the rear of the power supply.
2. Place the chassis on a stable hard surface and remove the chassis cover as described in the previous section.
3. Remove the two long screws at the front of the blower and the two long screws at the back of the blower and set them aside for later use.
4. Lift the blower up and out of the chassis and disconnect the wiring.
5. Replace the blower with another blower of the same model and reconnect the wiring.
6. Align the thru holes in the blower with the thru holes in the chassis.
7. Secure the blower to the chassis using the screws previously set aside.
8. Close the cover and reconnect the power cord to the power supply.

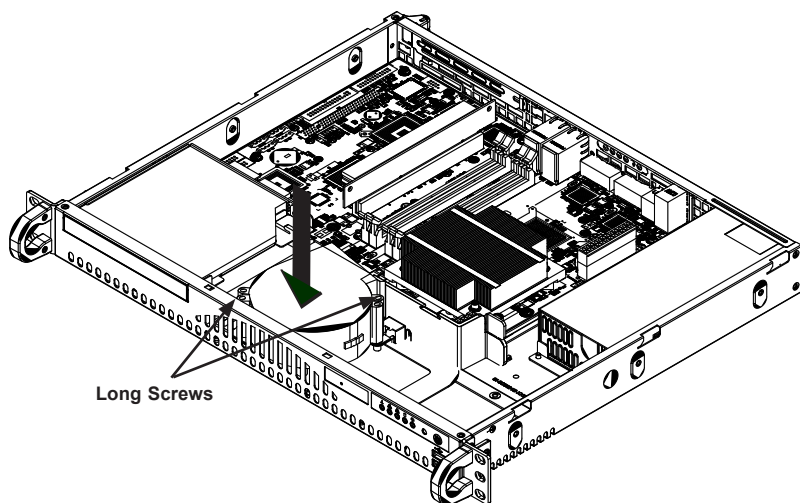

**Figure 6-4. Installing the Blower Fan**

## 6-5 Installing Hard Drives

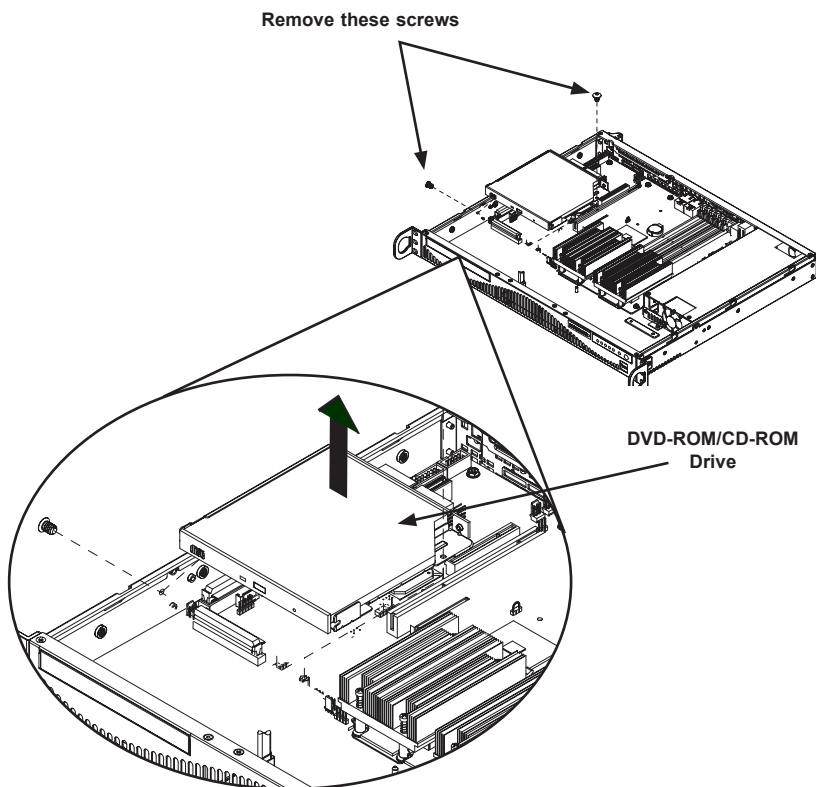
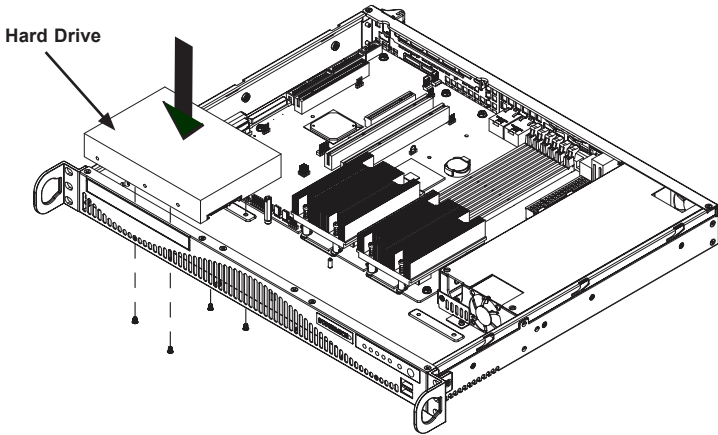

**Figure 6-5. Removing the CD-ROM Drive to Access the Hard Drive**

### *Installing a Hard Drive*

Before adding a hard drive, you must remove the DVD-ROM/CD-ROM drive as described in Section 6-6.

1. Power down the system and disconnect the power cord from the rear of the power supply. Place the chassis on a stable hard surface and remove the chassis cover as described in the Section 6-3.
2. If you have not already done so, remove the fan tray. For more information, see the Maintenance section located at the end of this chapter.
3. Remove the DVD-ROM/CD-ROM drive. To do this, remove the two screws holding the drive in place. One screw is external and the other is internal.



**Figure 6-6. Adding the Hard Drive**

4. Place the hard drive in the chassis as illustrated. Make sure the hard drive connectors face the inside of the chassis.
5. Secure the hard drive to the chassis using the four screws.
6. The chassis can support a second hard drive, which may be installed at this time.

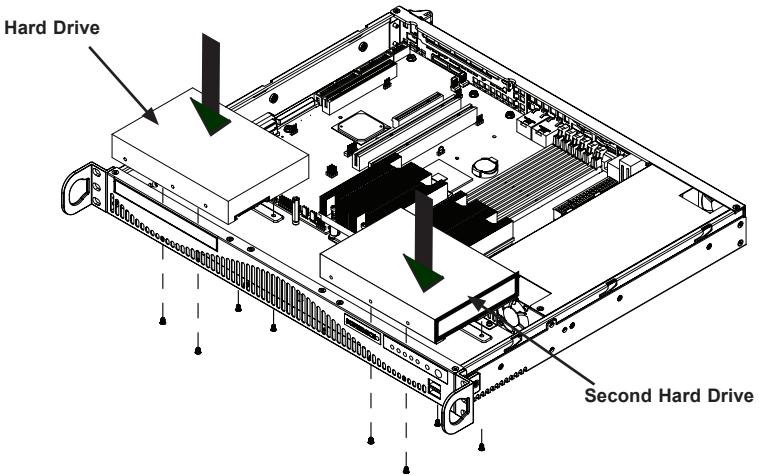

**Figure 6-7. Adding a Second Hard Drive**



## 6-6 PCI Slot Setup

An optional riser card (p/n RSC-RR1U-E8) may be installed into the PCI-E slot on the motherboard to support one full height, half-length expansion card. The PCI slot does not require a screw to hold the card in place.

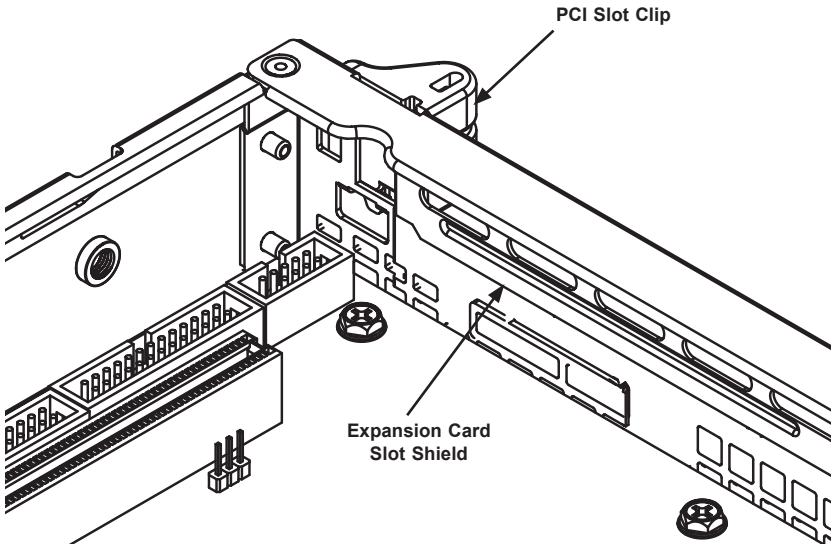

Figure 6-8. Installing the Expansion Card

### *Installing Expansion Cards*

1. Disconnect the power supply, lay the chassis on a flat surface, and open the chassis cover as described previously.
2. Slide the PCI slot clip upward.
3. Slide the PCI slot shield toward the side of the chassis and remove the shield.
4. Secure the riser card to the motherboard.
5. Simultaneously slide the expansion card (with "L" bracket) into the PCI slot and the riser card.
6. Replace the PCI slot clip to secure the expansion card.

## 6-7 Power Supply

The SC512 chassis includes a single 200 Watt power supply. This power supply is auto-switching capable, which enables it to automatically sense and operate at a 100v to 240v input voltage. An amber light will be illuminated on the power supply when the power is off. An illuminated green light indicates that the power supply is operating.

### Power Supply Failure

In the event that the power supply unit fails, the system will shut down and you will need to replace the power module.

Replacement units can be ordered directly from Supermicro (see contact information in the preface) or an authorized reseller.

#### *Replacing the Power Supply*

1. Power down the system and disconnect the power cord from the rear of the power supply.
2. Place the chassis on a stable hard surface and remove the chassis cover as described in Section 6-3.
3. Disconnect the power supply from the motherboard and other chassis components.
4. Remove the screws securing the power supply. Two screws are in the back of the chassis and one is underneath. Retain the screws and the internal brace that connects the power supply to the chassis from underneath.
5. Pull the power supply out of the chassis.
6. Place the new power supply into the chassis and secure the power supply using the three screws and internal brace.
7. Connect the power supply to the motherboard and other chassis components.
8. Connect the power cord to the power supply and power up the chassis/server.
9. Once you confirm that the power supply has been installed correctly, replace the chassis cover.

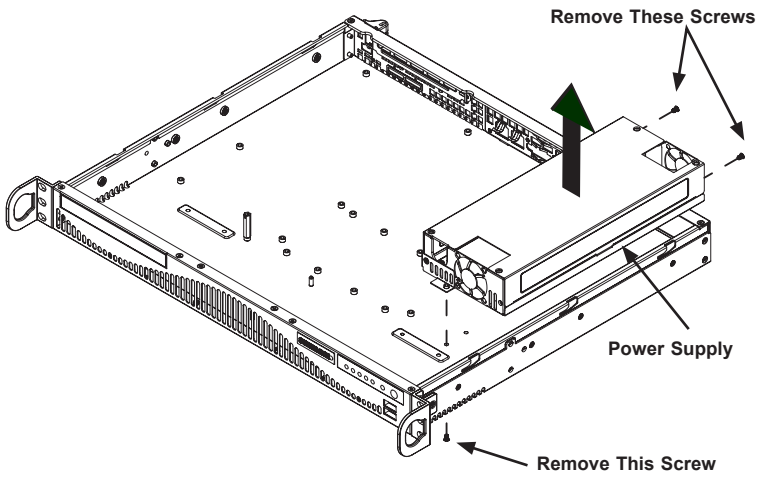

Figure 6-9. Removing the Power Supply

## Notes

# Chapter 7

## BIOS

### 7-1 Introduction

This chapter describes the AMI BIOS setup utility for the A1SAM/A1SRM Series Motherboard. The ROM BIOS is stored in a Flash EEPROM and can be easily updated. This chapter describes the basic navigation of the AMI BIOS setup utility setup screens.

**Note:** For AMI BIOS Recovery, please refer to the UEFI BIOS Recovery Instructions in Appendix C.

#### Starting BIOS Setup Utility

To enter the AMI BIOS setup utility screens, press the <Delete> key while the system is booting up.

**Note:** In most cases, the <Delete> key is used to invoke the AMI BIOS setup screen. There are a few cases when other keys are used, such as <F1>, <F2>, etc.

Each main BIOS menu option is described in this manual. The BIOS setup menu screen has two main frames. The left frame displays all the options that can be configured. Grayed-out options cannot be configured. Options in blue can be configured by the user. The right frame displays the key legend. Above the key legend is an area reserved for a text message. When an option is selected in the left frame, it is highlighted in white. Often a text message will accompany it. (**Note:** the AMI BIOS has default text messages built in. Supermicro retains the option to include, omit, or change any of these text messages.)

The AMI BIOS setup utility uses a key-based navigation system called "hot keys." Most of the AMI BIOS setup utility "hot keys" can be used at any time during the setup navigation process. These keys include <F1>, <F4>, <Enter>, <ESC>, arrow keys, etc.

**Note:** Options printed in **Bold** are default settings.

#### How To Change the Configuration Data

The configuration data that determines the system parameters may be changed by entering the AMI BIOS Setup utility. This Setup utility can be accessed by pressing <Del> at the appropriate time during system boot.

## How to Start the Setup Utility

Normally, the only visible Power-On Self-Test (POST) routine is the memory test. As the memory is being tested, press the <Delete> key to enter the Main menu of the AMI BIOS setup utility. From the Main menu, you can access the other setup screens. An AMI BIOS identification string is displayed at the left bottom corner of the screen, below the copyright message.

**Warning:** Do not upgrade the BIOS unless your system has a BIOS-related issue. Flashing the wrong BIOS can cause irreparable damage to the system. In no event shall Supermicro be liable for direct, indirect, special, incidental, or consequential damages arising from a BIOS update. If you have to update the BIOS, do not shut down or reset the system while the BIOS is updating. This is to avoid possible boot failure.

## 7-2 Main Setup

When you first enter the AMI BIOS setup utility, you will enter the Main setup screen. You can always return to the Main setup screen by selecting the Main tab on the top of the screen. The Main BIOS Setup screen is shown below.

The following Main menu items will display:

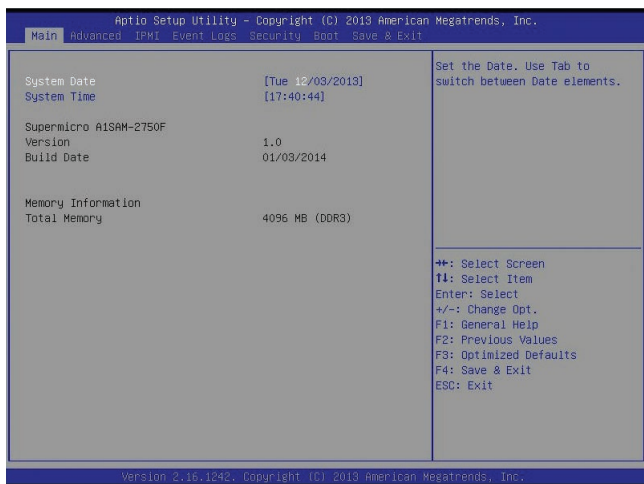

**System Date/System Time**

Use this option to change the system date and time. Highlight *System Date* or *System Time* using the arrow keys. Enter new values through the keyboard. Press the <Tab> key or the arrow keys to move between the fields. The date must be entered in Day MM/DD/YYYY format. The time is entered in HH:MM:SS format.

**Note:** The time is in the 24-hour format. For example, 5:30 P.M. appears as 17:30:00.

The following BIOS items will also be displayed:

**Model Name**

**Version**

**Build Date**

**Memory Information**

**Total Memory**

This displays the total size of memory available in the system.

## 7-3 Advanced Setup Configurations

Use the arrow keys to select Boot Setup and press <Enter> to access the submenu items:

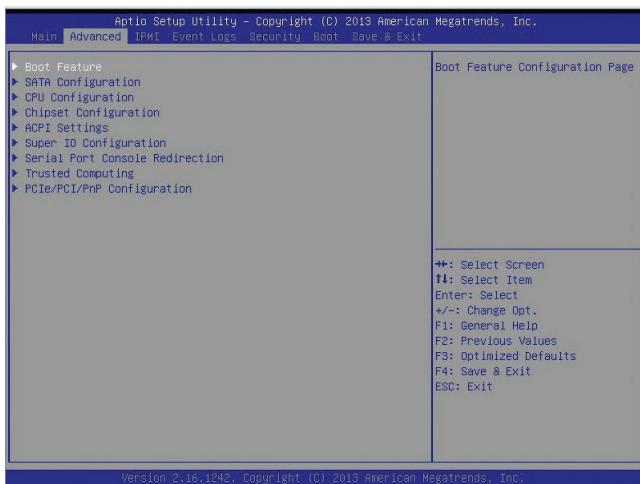

**Warning:** Use caution when changing the Advanced settings. An incorrect value, a very high DRAM frequency, or an incorrect DRAM timing setting may make the system unstable. When this occurs, revert the setting to its manufacture default setting.

### ► Boot Feature

#### Boot Configuration

##### Quiet Boot

This feature selects the screen display between POST messages or the OEM logo at bootup. Select Disabled to display the POST messages. Select Enabled to display the OEM logo instead of the normal POST messages. The options are **Enabled** and Disabled.

##### AddOn ROM Display Mode

This feature sets the display mode for the Option ROM. Select Keep Current to use the current AddOn ROM display setting. Select Force BIOS to use the Option ROM display mode set by the system BIOS. The options are **Force BIOS** and Keep Current.

##### Bootup Num-Lock

This feature selects the Power-on state for the Numlock key. The options are Off and **On**.



**Wait For 'F1' If Error**

This feature forces the system to wait until the 'F1' key is pressed if an error occurs. The options are Disabled and **Enabled**.

**Interrupt 19 Capture**

Interrupt 19 is the software interrupt that handles the boot disk function. When this item is set to Immediate, the BIOS ROM of the host adaptors will immediately capture Interrupt 19 at bootup and allow the drives that are attached to these host adaptors to function as bootable disks. If this item is set to Postponed, the BIOS ROM of the host adaptors will only capture Interrupt 19 during bootup from a legacy device. The options are **Immediate** and Postponed.

**Power Configuration****Watch Dog Function**

If enabled, the Watch Dog timer will allow the system to reboot when it is inactive for more than 5 minutes. The options are Enabled and **Disabled**.

**Power Button Function**

This feature controls how the system shuts down when the power button is pressed. Select 4\_Seconds\_Override for the user to power off the system after pressing and holding the power button for 4 seconds or longer. Select Instant Off to instantly power off the system as soon as the user presses the power button. The options are 4 Seconds Override and **Instant Off**.

**Restore on AC Power Loss**

Use this feature to set the power state after a power outage. Select Power-Off for the system power to remain off after a power loss. Select Power-On for the system power to be turned on after a power loss. Select Last State to allow the system to resume its last power state before a power loss. The options are Power-On, Stay-Off and **Last State**.

**►SATA Configuration**

When this submenu is selected, the AMI BIOS automatically detects the presence of the SATA Devices and displays the following items:

**SATA 3 Controller****SATA Controller**

This feature enables or disables the SATA Controller specified by the user. The options are **Enabled** and Disabled.

### **SATA Mode**

This item selects the mode for the installed SATA drives. The options are IDE and **AHCI**.

### **IDE Mode (Available when the item above: SATA Mode is set to IDE)**

Select Legacy for the SATA port specified by the user to support a Legacy SATA device. The options are **Legacy** and Native.

### **SATA 3 Speed**

Use this item to set the highest speed allowed for SATA interface connections for SATA 3 controller. The options are Gen 1, Gen 2, and **Gen 3**.

### **LPM (Line Power Management)**

Select Enabled to enable Line Power Management support. The options are Enabled and **Disabled**.

### **SATA Port0/Port1**

This item displays the information detected on the device installed on the particular SATA port.

- Model Name

### **SATA Port0/Port1**

Select Enabled to enable a SATA port selected by the user. The options are **Enabled** and Disabled.

### **Spin Up**

On an edge detect from 0 to 1, set this item to allow the PCH to start a COM-RESET initialization sequence to the device installed on a SATA port specified by the user. The options are Enabled and **Disabled**.

### **External Device**

Select Enabled for the SATA port specified by the user to support an external device. The options are Enabled and **Disabled**.

### **Hot Plug**

Select Enabled to enable hot-plugging support on a SATA drive specified by the user, which will allow the user to replace the SATA disk drive without shutting down the system. The options are **Enabled** and Disabled.

---

## SATA 2 Controller

### SATA Controller

This feature enables or disables the SATA Controller specified by the user. The options are **Enabled** and Disabled.

### SATA Mode

This item selects the mode for the installed SATA drives. The options are IDE and **AHCI**.

### LPM (Line Power Management)

Select Enabled to enable Line Power Management support. The options are Enabled and **Disabled**.

#### SATA Port 2 - SATA Port 5

This item displays the information detected on the device installed on the particular SATA port.

- Model Name

#### SATA Port 2/SATA Port 3/SATA Port 4/SATA Port 5

Select Enabled to enable a SATA port selected by the user. The options are **Enabled** and Disabled.

### Spin Up

On an edge detect from 0 to 1, set this item to allow the PCH to start a COM-RESET initialization sequence to the device installed on a SATA port specified by the user. The options are Enabled and **Disabled**.

### External Device

Select Enabled for the SATA port specified by the user to support an external device. The options are Enabled and **Disabled**.

### Hot Plug

Select Enabled to enable hot-plugging support on a SATA drive specified by the user, which will allow the user to replace the SATA disk drive without shutting down the system. The options are Enabled and **Disabled**.

## ►CPU Configuration

The following CPU information will be displayed:

- Processor ID

- Processor Frequency
- Microcode Revision
- L1 Cache RAM
- L2 L1 Cache RAM
- Processor Version

### **Clock Spread Spectrum**

If this feature is set to Enabled, the BIOS will monitor the level of Electromagnetic Interference caused by the components and will attempt to reduce the interference when needed. The options are Enabled and **Disabled**.

### **EIST (GV3)**

EIST (Enhanced Intel SpeedStep Technology) allows the system to automatically adjust processor voltage and core frequency in an effort to reduce power consumption and heat dissipation. The options are Disabled, Enabled, and **Auto**.

### **P-State Coordination**

This feature selects the type of coordination for the P-State of the processor. P-State is a processor operational state that reduces the processor's voltage and frequency. This makes the processor more energy efficient, resulting in further energy gains. The options are Hardware, **Package**, and Module.

### **TM1 (Available when supported by the CPU.)**

Select Enabled to activate CPU's internal thermal monitor mechanism which will allow the CPU to regulate its power consumption based on the modulation of its internal clock when the CPU temperature reaches a pre-defined overheat threshold. The options are Disabled and **Enabled**.

### **TM2 Mode (Available when the item above-TM1 is Enabled)**

This feature is used to set the TM2 mode. The options are LFM Throttling, and **Adaptive Throttling**.

### **CPU C State**

The CPU C-State architecture is a processor power management platform developed by Intel to reduce power consumption by blocking clock cycles to the CPU during C1 State (Halt State). Select Enabled for CPU C-States support. The options are **Auto**, Enabled, and Disabled.

**Package C State limit**

Select Auto for the AMI BIOS to automatically set the limit on the C-State packaging register. The options are **No Limit**, C1 state, C2 state, C3 state, C4 state, and C6 (non Retention) state.

**Enhanced Halt State (C1E)**

Select Enabled for "Enhanced Halt State" (C1E) support, which will significantly reduce the CPU's power consumption by reducing the CPU's clock cycle and voltage during a Halt State. The options are Disabled and **Enabled**.

**Monitor/Mwait**

If this feature is set to Enabled, the processor will carry out the "Monitor/Mwait" instruction by specifying an address on which to wait (Monitor) and giving an instruction to start the "wait operation" (Mwait). The options are Disabled and **Enabled**.

**L1 Prefetcher (Available when supported by the CPU)**

If set to Enabled, the L1 cache prefetcher will prefetch streams of data and instructions from the main memory to the L1 cache to improve CPU performance. The options are Disabled and **Enabled**.

**L2 Prefetcher (Available when supported by the CPU)**

If set to Enabled, the L2 cache prefetcher will prefetch streams of data and instructions from the L1 cache to the L2 cache to improve CPU performance. The options are Disabled and **Enabled**.

**ACPI 3.0 T-States (Available when supported by the CPU)**

Select Enabled to support Advanced Configuration and Power Interface (ACPI) 3.0 T-States, which will allow the CPU driver to receive \_TPC change notifications for CPU speed control to improve system cooling. The options are Enabled and **Disabled**.

**Max CPUID Limit**

Select Enabled to set the maximum CPU ID value and to boot the legacy operating systems that cannot support processors with extended CPUID functions. The options are Enabled and **Disabled** (for the Windows OS).

**Execute-Disable Bit (Available if supported by the OS & the CPU)**

Set to Enabled to provide Execute Disable Bit support which will allow the processor to designate areas in the system memory where an application code can execute and where it cannot, thus preventing a worm or a virus from flooding illegal codes to overwhelm the processor or damage the system during an attack. The default is **Enabled**. (Refer to Intel and Microsoft Web Sites for more information.)

**VMX (Available when supported by the CPU)**

Select Enabled to use Intel's Vanderpool Technology to allow one platform to run multiple operating systems and applications in independent partitions, creating multiple "virtual" systems in one physical computer. The options are **Enabled** and Disabled. (Please reboot the system for the change on the setting to take effect.)

**AES-NI**

Select Enabled for Advanced\_Encryption-Standard (AES) support which will increase security and data integrity in the processor. The options are **Enabled** and Disabled.

**Active Processor Cores**

This feature determines how many CPU cores will be activated for each CPU. When all is selected, all cores in the CPU will be activated. (Please refer to Intel's website for more information.) The options are **All**, 4, and 2.

**►Chipset Configuration**

**Warning!** Setting the wrong values in the following sections may cause the system to malfunction.

**►System Agent (SA) Configuration****Memory Information**

The following memory information will be displayed:

- MRC Version
- Total Memory
- Memory Frequency
- ECC Support

**Memory Frequency**

This feature sets the memory frequency for DIMM modules installed on the motherboard. The options are **Auto**, DDR3-1333 (MHz), and DDR3-1600 (MHz).

**CKE Power Down**

Select Enabled for the BIOS to control the low power mode for the RAM during active power standby mode. The options are **Enabled** and Disabled.

**Patrol Scrub Enable**

Patrol Scrubbing is a process that allows the CPU to correct correctable memory errors detected on a memory module and send the correction to the requestor (the original source). When this item is set to Enabled, the IO hub will read and write back one cache line every 16K cycles, if there is no delay caused by internal processing. By using this method, roughly 64 GB of memory behind the IO hub will be scrubbed every day. The options are **Enabled** and Disabled.

**Demand Scrub Enable**

Demand Scrubbing is a process that allows the CPU to correct correctable memory errors found on a memory module. When the CPU or I/O issues a demand-read command, and the read data from memory turns out to be a correctable error, the error is corrected and sent to the requestor (the original source). Memory is updated as well. Select Enabled to use Demand Scrubbing for ECC memory correction. The options are **Enabled** and Disabled.

**CMD Rate**

Use this feature to set the command-line execution rate for your computer. The options are **Atuo**, 1N, 2N, and 3N.

**Dynamic Self Refresh**

Select Enabled to enable Dynamic Self Refresh support in the memory controller to maximize memory performance. The options are **Enabled** and Disabled.

**Memory Thermal**

This feature is used to configure the Memory Thermal Management mode. The options are **Disabled** and CLTT (Closed-Loop Thermal Throttling).

**2x Refresh Rate**

Select Enabled to force the system to use 2x memory refreshing rate regardless what the temperature is. The options are **Disabled** and Enabled.

**►I/O Fabric**

The following items will be displayed:

- USB Module Version
- USB Devices

### Legacy USB Support

Select Enabled to use legacy USB devices in the computer. Select Auto for your BIOS to automatically enable legacy USB support if a legacy USB device is detected in your computer. The options are **Enabled**, Disabled, and Auto.

### EHCI Hand-Off

This item is for Operating Systems that do not support Enhanced Host Controller Interface (EHCI) hand-off. When this item is enabled, EHCI ownership change will be claimed by the EHCI driver. The settings are Enabled and **Disabled**.

### USB Mass Storage Driver Support

Select Enabled for USB mass storage device support. The options are Disabled and **Enabled**.

### Port 60/64 Emulation

Select Enabled for I/O port 60h/64h emulation support. This feature should be enabled for complete USB keyboard legacy support for non-USB-aware operating systems. The options are Disabled and **Enabled**.

### USB KB (Keyboard)/MS (Mouse) Wake

Select Enabled for the system to "wake-up" when a signal is received by the USB keyboard or mouse. The options are **Disabled** and Enabled.

## ►ACPI Settings

### ACPI Settings

#### High Precision Timer

Select Enabled to activate the High Precision Event Timer (HPET) that produces periodic interrupts at a much higher frequency than a Real-time Clock (RTC) does in synchronizing multimedia streams, providing smooth playback and reducing the dependency on other timestamp calculation devices, such as an x86 RDTSC Instruction embedded in the CPU. The High Performance Event Timer is used to replace the 8254 Programmable Interval Timer. The options are **Enabled** and Disabled.

#### WHEA Support

Select Enables to enable WHEA (Windows Hardware Error Architecture) support for the Windows 2008 operating system (and later versions). The options are **Enabled** and Disabled.



## Native AER

Select Enabled to enable Native Advanced Error Reporting support which will expand error-reporting capability. The options are **Enabled** and Disabled.

## ► Super IO Configuration

### AST2400 Super IO Chip AST2400

#### ► COM1 Configuration/COM2 Configuration

##### Serial Port

Select Enabled to enable the onboard serial port specified by the user. The options are **Enabled** and Disabled. If the serial port selected by the user is enabled, the following items will be displayed.

##### Device Settings (For Serial Port 1 / Serial Port 2)

This item displays the device setting for a serial port selected by the user.

##### Change Settings (For Serial Port 1 / Serial Port 2)

This option specifies the base I/O port address and the Interrupt Request address of Serial Port 1 and 2. Select Auto to let the BIOS automatically assign the base I/O and IRQ address.

The options for Serial Port 1 are **Auto**, (IO=3F8h; IRQ=4), (IO=3F8h; IRQ=3, 4, 5, 6, 7, 10, 11, 12), (IO=2F8h; IRQ=3, 4, 5, 6, 7, 10, 11, 12), (IO=3E8h; IRQ=3, 4, 5, 6, 7, 10, 11, 12) and (IO=2E8h; IRQ=3, 4, 5, 6, 7, 10, 11, 12).

The options for Serial Port 2 are **Auto**, (IO=2F8h; IRQ=3), (IO=3F8h; IRQ=3, 4, 5, 6, 7, 10, 11, 12), (IO=2F8h; IRQ=3, 4, 5, 6, 7, 10, 11, 12), (IO=3E8h; IRQ=3, 4, 5, 6, 7, 10, 11, 12) and (IO=2E8h; IRQ=3, 4, 5, 6, 7, 10, 11, 12).

##### Serial Port 2 Attribute

Use this feature to select the attribute for serial port 2. The options are **SOL** (Serial On LAN), and COM.

## ► Serial Port Console Redirection

### COM1/COM2

Use this feature to enable console redirection for COM1 and COM2 ports. The options are Enabled and Disabled. The default setting for COM1 is **Disabled** and the default for COM2 is Enabled. When the console redirection support for a selected COM port is enabled, the following items will be displayed.

## ► Console Redirection Settings

This feature allows the user to specify how the host computer will exchange data with the client computer, which is the remote computer used by the user.

### Terminal Type

This feature allows the user to select the target terminal emulation type for console redirection. Select VT100 to use the ASCII Character set. Select VT100+ to add color and function key support. Select ANSI to use the Extended ASCII Character Set. Select VT-UTF8 to use UTF8 encoding to map Unicode characters into one or more bytes. The options are ANSI, VT100, **VT100+**, and VT-UTF8.

### Bits Per second

Use this feature to set the transmission speed for a serial port used in console redirection. Make sure that the same speed is used in the host computer and the client computer. A lower transmission speed may be required for long and busy lines. The options are 9600, 19200, 38400, 57600, and **115200** (bits per second).

### Data Bits

Use this feature to set the data transmission size for console redirection. The options are 7, and **8 (Bits)**.

### Parity

A parity bit can be sent along with regular data bits to detect data transmission errors. Select Even if the parity bit is set to 0, and the number of 1's in data bits is even. Select Odd if the parity bit is set to 0, and the number of 1's in data bits is odd. Select None if you do not want to send a parity bit with your data bits in transmission. Select Mark to add a mark as a parity bit to be sent along with the data bits. Select Space to add a Space as a parity bit to be sent with your data bits. The options are **None**, Even, Odd, Mark and Space.

### Stop Bits

A stop bit indicates the end of a serial data packet. Select 1 Stop Bit for standard serial data communication. Select 2 Stop Bits if slower devices are used. The options are **1** and 2.

### Flow Control

Use this feature to set the flow control for console redirection to prevent data loss caused by buffer overflow. Send a "Stop" signal to stop sending data when the receiving buffer is full. Send a "Start" signal to start sending data when the receiving buffer is empty. The options are **None**, and Hardware RTS/CTS.

**VT-UTF8 Combo Key Support**

Select Enabled to enable VT-UTF8 Combination Key support for ANSI/VT100 terminals. The options are **Enabled**, and Disabled.

**Recorder Mode**

Select Enabled to capture the data displayed on a terminal and send it as text messages to a remote server. The options are **Disabled** and Enabled.

**Resolution 100x31**

Select Enabled for extended-terminal resolution support. The options are Disabled and **Enabled**.

**Legacy OS Redirection Resolution**

Use this feature to select the number of rows and columns used in console redirection for legacy OS support. The options are 80x24 and **80x25**.

**Putty KeyPad**

This feature selects Function Keys and KeyPad settings for Putty, which is a terminal emulator designed for the Windows OS. The options are **VT100**, LINUX, XTERMR6, SC0, ESCN, and VT400.

**Redirection After BIOS Post**

Use this feature to enable or disable legacy console redirection after BIOS POST. When this item is set to Bootloader, legacy console redirection is disabled before booting the OS. When this item is set to Always Enable, legacy console redirection remains enabled when booting the OS. The options are **Always Enable** and Bootloader.

**Serial Port for Out-of-Band Management/Windows Emergency Management Services (EMS)**

The submenu allows the user to configure console redirection settings to support Out-of-Band Serial Port management.

**EMS Console Redirection**

Select Enabled to use a COM port selected by the user for console redirection (for out-of-band emergency management services). The options are **Enabled** and Disabled. When this item is set to Enabled, the following submenu will display.

## ► Console Redirection Settings (for EMS)

This feature allows the user to specify how the host computer will exchange data with the client computer, which is the remote computer used by the user.

### Out-of-Band Management Port

The feature selects a serial port used by the Microsoft Windows Emergency Management Services (EMS) to communicate with a remote server. The options are **COM1** and COM2/SOL.

### Terminal Type

This feature allows the user to select the target terminal emulation type for console redirection. Select VT100 to use the ASCII character set. Select VT100+ to add color and function key support. Select ANSI to use the extended ASCII character set. Select VT-UTF8 to use UTF8 encoding to map Unicode characters into one or more bytes. The options are ANSI, VT100, **VT100+**, and VT-UTF8.

### Bits Per Second

This item sets the transmission speed for a serial port used in console redirection. Make sure that the same speed is used in the host computer and the client computer. A lower transmission speed may be required for long and busy lines. The options are 9600, 19200, 57600, and **115200** (bits per second).

### Flow Control

This feature allows the user to set the flow control for Console Redirection to prevent data loss caused by buffer overflow. Send a "Stop" signal to stop sending data when the receiving buffer is full. Send a "Start" signal to start sending data when the receiving buffer is empty. The options are **None**, Hardware RTS/CTS, and Software Xon/Xoff.

The following items will also be displayed:

### Data Bits, Parity, Stop Bits

The status of each item above is displayed.

## ► Trusted Computing Configuration (Available when a TPM Device is Detected and TPM Jumper is Enabled)

### Configuration

#### Security Device Support

Select Enabled for the AMI BIOS to automatically download the drivers needed to provide Trusted Computing platform support for this machine to ensure data integrity and network security. The options are **Disabled** and Enabled.

**TPM State**

Select Enabled to use TPM (Trusted Platform Module) settings for system data security. The options are Disabled and **Enabled**.

**Note:** The system will reboot for the change on TPM State to take effect.

**Pending Operation**

Use this item to schedule a TPM-related operation to be performed by a security device for TPM support. The options are **None**, Enable Take Ownership, Disable Take Ownership, and TPM Clear.

**Note:** The computer will reboot to carry out a pending TPM operation and change TPM state for a TPM device.

**Current Status Information**

This feature indicates the status of the following TPM items:

**TPM Enabled Status****TPM Active Status****TPM Owner Status****►PCI/PCI/PnP Configuration**

This feature allows the user to set the PCI/PnP configurations for the following items:

**VGA Palette Snoop**

Select Enabled to support VGA palette register snooping which will allow the PCI cards that do not contain their own VGA color palette to examine the video cards palette and mimic it for proper color display. The options are **Disabled**, and Enabled.

**PERR# Generation**

Select Enabled to allow a PCI device to generate a PERR number for a PCI Bus Signal Error Event. The options are **Disabled** and Enabled.

**SERR# Generation**

Select Enabled to allow a PCI device to generate an SERR number for a PCI Bus Signal Error Event. The options are Enabled and **Disabled**.

### Above 4G Decoding

Select Enabled for 64-bit devices to be decoded above the 4GB address space if 64-bit PCI decoding is supported by the system. The options are **Disabled** and Enabled.

### Storage

This feature allows the user to determine how the system handles UEFI and Legacy Storage OpROM instructions. The options are Do not Launch, **UEFI**, and Legacy.

### CPU1 Slot 4 PCI-E 2.0x4 OPROM/CPU1 Slot 6 PCI-E 2.0x8 OPROM

Use this feature to configure the Option ROM (OPROM) setting for a PCI-E slot specified by the user. Option ROM allows the computer to boot up using a device installed on the slot specified. The options are Disabled, **Legacy** and EFI.

### Onboard LAN1 Option ROM/Onboard LAN2 Option ROM/ Onboard LAN3 Option ROM/Onboard LAN4 Option ROM

This feature allows the user to configure the Option ROM (OPROM) setting for a PCI-E slot specified by the user. Option ROM allows the computer to bootup using a device installed on the slot specified. Select iSCSI to use the iSCSI Option ROM to boot the computer using an iSCSI device installed in a LAN port specified. Select PXE (Preboot Execution Environment) to boot the computer using a PXE device installed in a LAN port specified. Select Disabled to prevent system boot using a device installed in a LAN port. The options are Onboard LAN1 Option ROM are Disabled, **PXE** and iSCSI. The options for Onboard LAN2 Option ROM, LAN3 Option ROM, and LAN4 Option ROM are **Disabled** and PXE.

### Network Stack

Select Enabled to enable UEFI (Unified Extensible Firmware Interface) for network stack support. The options are Enabled and **Disabled**.

### Ipv4 PXE Support (Available when Network Stack is set to Enabled)

Select Enabled to enable Ipv4 PXE (Preboot Execution Environment) for boot support. If this feature is set to Disabled, Ipv4 PXE boot option will not be supported. The options are **Enabled** and Disabled.

### Ipv6 PXE Support (Available when Network Stack is set to Enabled)

Select Enabled to enable Ipv6 PXE (Preboot Execution Environment) for boot support. If this feature is set to Disabled, Ipv6 PXE boot option will not be supported. The options are Enabled and **Disabled**.

**Maximum Payload Size**

Use this feature to set the maximum payload size for a PC-E slot. The options are **Auto**, 128 Bytes, and 256 Bytes.

**Maximum Read Request**

Select Auto to allow the system BIOS to automatically set the maximum Read Request size for a PCI-E device to enhance system performance. The options are **Auto**, 128 Bytes, 256 Bytes, 512 Bytes, 1024 Bytes, 2048 Bytes, and 4096 Bytes.

**ASPM Support**

This feature allows the user to set the Active State Power Management (ASPM) level for a PCI-E device. Select Auto to allow the system BIOS to automatically set the ASPM level for the system. Select Disabled to disable ASPM support. The options are **Disabled**, and Auto.

**Warning:** Enabling ASPM support may cause some PCI-E devices to fail!

## 7-4 IPMI Configuration

Intelligent Platform Management Interface (IPMI) is a set of common interfaces that are used to monitor the system health of each computer connected to a network from a remote site. For more information on the IPMI specifications, please visit Intel's website at [www.intel.com](http://www.intel.com).

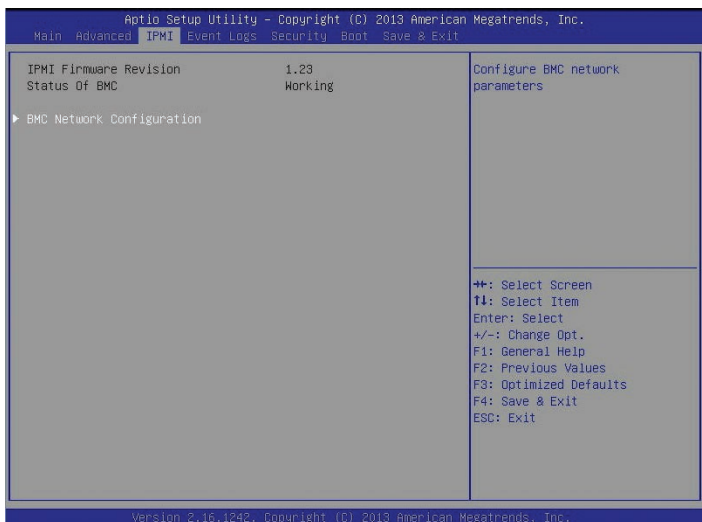

The following items are displayed:

IPMI Firmware Revision

Status of BMC (Baseboard Management Controller)

### ►BMC (Baseboard Management Controller) Network Configuration

BMC Network Configuration

LAN Channel 1

### Update IPMI LAN Configuration

Select Yes to allow the BIOS to set the IPMI features listed below upon next system boot. The options are **No** and Yes.

### Configuration Address Source

This feature selects whether the IP address, Subnet Mask and Gateway Address are automatically assigned by the network's DHCP server (Dynamic Host and Configuration Protocol) or manually entered by the user (Static). If DHCP is selected, the following items will be automatically set by the BIOS. If Static is selected, the IP Address, Subnet Mask and Gateway Address must be manually entered below. The options are Static and **DHCP**.



**Station IP Address**

Use this item to enter the IP address for this machine. This should be in decimal and in dotted quad form (i.e., 192.168.10.253). The value of each three-digit number separated by dots should not exceed 255.

**Subnet Mask**

Use this item to enter the IP address for subnet masks of this machine. The value of each three-digit number separated by dots should not exceed 255.

**Station MAC Address**

The BIOS will automatically enter the Station MAC address of this machine; however, it may be over-ridden by manually entering another address. MAC addresses are 6 two-digit hexadecimal numbers (Base 16, 0 ~ 9, A, B, C, D, E, F) separated by dots. (i.e., 00.30.48.D0.D4.60)

**Router IP Address**

Use this item to enter the Gateway or the router address for this machine (i.e., 192.168.10.1).

**Router MAC Address**

Use this item to enter the router MAC address for this machine.

## 7-4 Event Logs

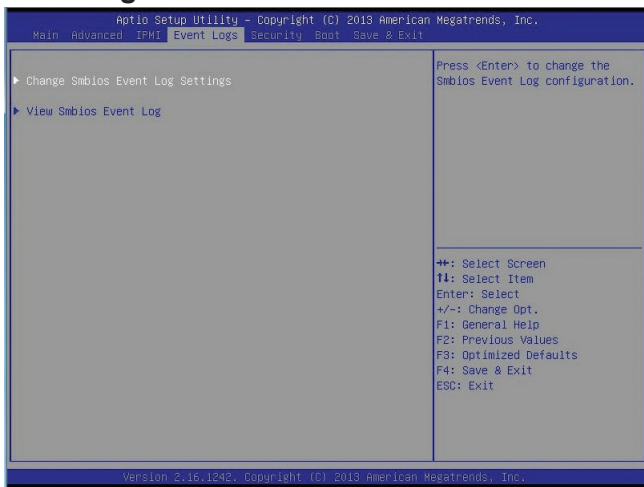

### ►Change SMBIOS Event Log Settings

#### Enabling/Disabling Options

##### SMBIOS Event Log

Select Enabled to enable all features of the SMBIOS Event Logging upon the next system boot. The options are **Enabled** and Disabled.

##### System Error Logging

Select Enabled to enable system error logging, which will allow the BIOS to log system errors upon the next system boot . The options are **Enabled** and Disabled.

#### Erasing Settings

##### Erase Event Log

If No is selected, data stored in the event log will not be erased. Select Yes, Next Reset, data in the event log will be erased upon next system reboot. Select Yes, Every Reset, data in the event log will be erased upon every system reboot. The options are **No**, Yes, Next reset, and Yes, Every reset.

##### When Log is Full

Select Erase Immediately for all messages to be automatically erased from the event log when the event log memory is full. The options are **Do Nothing** and Erase Immediately.

## Smbios Event Long Standard Settings

### SMBIOS Event Long Standard Settings

#### Log System Boot Event

This option toggles the System Boot Event logging to enabled or disabled. The options are **Disabled** and Enabled.

#### MECI

The Multiple Event Count Increment (MECI) counter counts the number of occurrences a duplicate event must happen before the MECI counter is incremented. This is a numeric value. The default value is **1**.

#### METW

The Multiple Event Time Window (METW) defines number of minutes must pass between duplicate log events before MECI is incremented. This is in minutes, from 0 to 99. The default value is **60**.

### ►View SMBIOS Event Log

This section displays the contents of the SMBIOS Event Logging.

- Date
- Time
- Error Code
- Severity

## 7-5 Security Settings

This menu allows the user to configure the following security settings for the system.

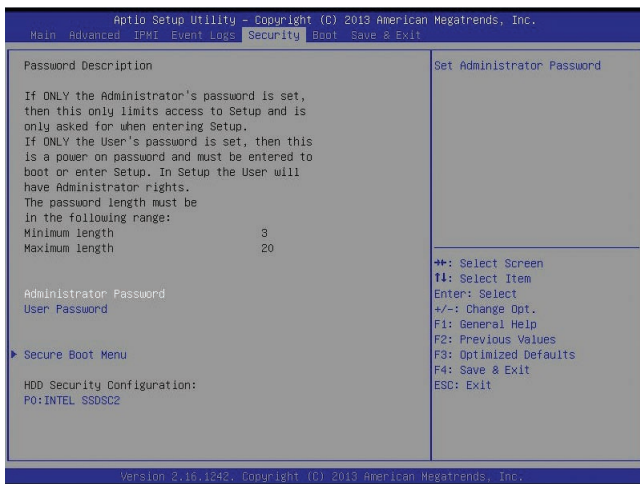

### Administrator Password

Use this feature to set the Administrator Password which is required to enter the BIOS setup utility. The length of the password should be from 3 characters to 8 characters long.

### User Password

Use this feature to set a User Password which is required to log into the system and to enter the BIOS setup utility. The length of the password should be from 3 characters to 8 characters long.

### ►Secure Boot Menu

The following items will be displayed.

System Mode

Secure Boot

#### Secure Boot

Select Enabled to enable secure boot support to ensure system security upon bootup. The options are Enabled and **Disabled**.

#### Secure Boot Mode

Use this feature to set secure boot mode to ensure system security upon bootup. The options are **Customer** and Standard.

**►Key Management**

This submenu allows the user to configure the following Key Management settings.

**Default Key Provision**

Select Enabled to install the default Secure-Boot keys set by the manufacturer. The options are **Disabled** and Enabled.

**►Enroll All Factory Default Keys**

Select Yes to install all default secure keys set by the manufacturer. The options are **Yes** and No.

**Save All Secure Boot Variables**

This feature allows the user to decide if all secure boot variables should be saved.

**Platform Key (PK)**

This feature allows the user to configure the settings of the platform keys.

**Delete PK (Platform Keys)**

This feature allows the user to configure the settings for platform keys deletion.

**►Set New PK (Platform Keys)**

Select Yes to load the new platform keys from the manufacturer's defaults. Select No to load the platform keys from a file. The options are **Yes** and No.

**Key Exchange Key DataBase (KEK)****►Delete KEK (Key Exchange Key)**

Select Yes to delete the KEK from the manufacturer's defaults. Select No to load the KEK from a file. The options are **Yes** and No.

**►Set New KEK (Key Exchange Key)**

Select Yes to set a new KEK from the manufacturer's defaults. Select No to load the KEK from a file. The options are **Yes** and No.

**►Append KEK (Key Exchange Key)**

Select Yes to add the KEK from the manufacturer's defaults list to the existing KEK. Select No to load the KEK from a file. The options are **Yes** and No.

### **Authorized Signatures (DB)**

#### **► Delete DB**

Select Yes to delete the database of "Authorized Signatures" from the manufacturer's defaults. Select No to load the DB from a file. The options are **Yes** and No.

#### **► Set New DB**

Select Yes to load the DB database from the manufacturer's defaults. Select No to load the DB from a file. The options are **Yes** and No.

#### **► Append DB**

Select Yes to add the DB database from the manufacturer's defaults to the existing DB. Select No to load the DB from a file. The options are **Yes** and No.

### **Authorized Timestamps (DBT)**

#### **► Delete DBT**

Select Yes to delete the database of "Authorized Timestamps" (DBT) from the manufacturer's defaults. Select No to load the DB from a file. The options are **Yes** and No.

#### **► Set New DBT**

Select Yes to load the DBT database from the manufacturer's defaults. Select No to load the DB from a file. The options are **Yes** and No.

#### **► Append DBT**

Select Yes to add the DBT database from the manufacturer's defaults to the existing DB. Select No to load the DB from a file. The options are **Yes** and No.

### **Forbidden Signature Database (DBX)**

#### **► Set New DBX**

Select Yes to load the DBX from the manufacturer's defaults. Select No to load the DBX from a file. The options are **Yes** and No.

#### **► Append DBX**

Select Yes to add the DBX from the manufacturer's defaults to the existing DBX. Select No to load the DBX from a file. The options are **Yes** and No.

### **HDD Security Configuration**

This item displays the HDD security setting status.

P0: INTEL SS0SC2.

## 7-6 Boot Settings

Use this feature to configure Boot Settings:

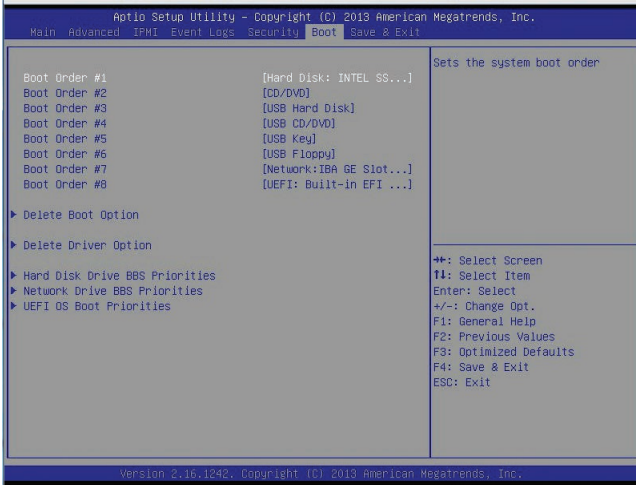

This submenu allows the user to prioritize the sequence of bootable devices for the system to boot from.

- Boot Order #1
- Boot Order #2
- Boot Order #3
- Boot Order #4
- Boot Order #5
- Boot Order #6
- Boot Order #7
- Boot Order #8

### ▶ Delete Boot Option

Use this feature to remove a pre-defined boot device from which the system will boot during startup.

#### Delete Boot Option

Select a bootable device to remove it from the boot device list so that the system can no longer boot from this device.

▶ **Delete Driver Option**

This feature allows the user to delete a previously defined boot device from which the systems boots during startup.

**Delete Boot Drive Option**

Select a bootable drive to remove it from the boot drive list so that the system can no longer boot from this drive.

▶ **Hard Disk Drive BBS Priorities**

- Boot Order #1

▶ **Network Device BBS Priorities**

- Boot Order #1

▶ **UEFI OS Boot Priorities**

- Boot Order #1



## 7-7 Save & Exit

Select the Exit tab from the BIOS setup utility screen to enter the Exit BIOS Setup screen.

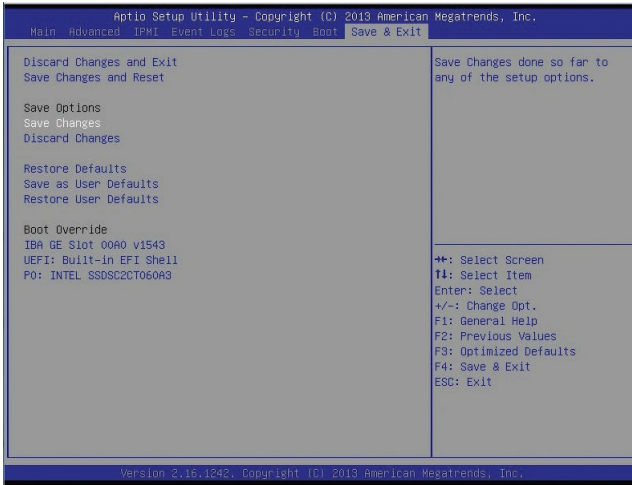

### Discard Changes and Exit

Select this option to quit the BIOS Setup without making any permanent changes to the system configuration, and reboot the computer. Select Discard Changes and Exit from the Exit menu and press <Enter>.

### Save Changes and Reset

When you have completed the system configuration changes, select this option to leave the BIOS setup utility and reboot the computer, so the new system configuration parameters can take effect. Select Save Changes and Exit from the Exit menu and press <Enter>.

### Save Options

### Save Changes

When you have completed the system configuration changes, select this option to save any changes made. This will not reset (reboot) the system.

### Discard Changes

Select this option and press <Enter> to discard all the changes and return to the AMI BIOS Utility Program.

### **Restore Optimized Defaults**

To set this feature, select Restore Defaults from the Exit menu and press <Enter>. These are factory settings designed for maximum system stability, but not for maximum performance.

### **Save As User Defaults**

To set this feature, select Save as User Defaults from the Exit menu and press <Enter>. This enables the user to save any changes to the BIOS setup for future use.

### **Restore User Defaults**

To set this feature, select Restore User Defaults from the Exit menu and press <Enter>. Use this feature to retrieve user-defined settings that were saved previously.

### **Boot Override**

Listed on this section are other boot options for the system (i.e., Built-in EFI shell). Select an option and press <Enter>. Your system will boot to the selected boot option.

IBA GE Slot 00A0 v1543

UEFI: Built-in EFI Shell

P0: INTEL SSDSC2CT060A3

## Appendix A

### BIOS Post Error Codes

During the POST (Power-On Self-Test) routines, which are performed each time the system is powered on, errors may occur.

**Non-fatal errors** are those which, in most cases, allow the system to continue the boot-up process. The error messages normally appear on the screen.

**Fatal errors** are those which will not allow the system to continue the boot-up procedure. If a fatal error occurs, you should consult with your system manufacturer for possible repairs.

These fatal errors are usually communicated through a series of audible beeps. The numbers on the fatal error list correspond to the number of beeps for the corresponding error.

BIOS Error Beep Codes		
Beep Code/LED	Error Message	Description
1 beep	Refresh	Circuits have been reset. (Ready to power up)
5 short beeps + 1 long beep	Memory error	No memory detected in the system
8 beeps	Display memory read/write error	Video adapter missing or with faulty memory
OH LED On	System OH	System Overheat

## Notes

# Appendix B

## System Specifications

### Processor

Single Intel® C2000 Tri-Gate 22nm SoC (System-on-a Chip) Series processor in an FCBGA 1283 package (embedded processor)

Note: refer to our web site for details on supported processors and operating systems.

### BIOS

128Mb SPI AMI BIOS® SM Flash BIOS

### Memory Capacity

Four memory slots that support up to 64GB of DDR3-1600/1333 ECC/non-ECC Unbuffered memory (UDIMMs)

Note: refer to Section 5-6 for details and to our web site for updates to supported memory.

### Drive Bays

Two internal 3.5" SATA drives supported

### PCI Expansion

One PCI-Express 2.0 x8 card

Note: requires optional riser card (RSC-RR1U-E8) installed. Refer to page 6-8 for details.

### Motherboard

A1SAM-2550F (Mini-ITX form factor)

Dimensions: 9.6 x 7.5 in (243.8 x 190.5 mm)

### Chassis

SC512L-200B (1U Rackmount)

Dimensions: (WxHxD) 16.8 x 1.7 x 14 in. (426 x 43 x 356 mm)

### Weight

System Weight: 12.5 lbs. (5.68 kg.)

## **System Input Requirements**

AC Input Voltage: 100-240VAC auto-range

Rated Input Current: 5.5-4A (100-140V), 3.5-2.5A (180-240V)

Rated Input Frequency: 50 to 60 Hz

## **Power Supply**

Rated Output Power: 200W (Part# PWS-202-1H)

Rated Output Voltages: +3.3V (8A), +5V (8A), +12V (16A), -12V (0.5A), +5Vsb (2A)

## **Operating Environment**

Operating Temperature: 10° to 35° C (50° to 95° F)

Non-operating Temperature: -40° to 70° C (-40° to 158° F)

Operating Relative Humidity: 8% to 90% (non-condensing)

Non-operating Relative Humidity: 5 to 95% (non-condensing)

## **Regulatory Compliance**

Electromagnetic Emissions: FCC Class A, EN 55022 Class B, EN 61000-3-2/-3-3, CISPR 22 Class B

Electromagnetic Immunity: EN 55024/CISPR 24, (EN 61000-4-2, EN 61000-4-3, EN 61000-4-4, EN 61000-4-5, EN 61000-4-6, EN 61000-4-8, EN 61000-4-11)

Safety: CSA/EN/IEC/UL 60950-1 Compliant, UL or CSA Listed (USA and Canada), CE Marking (Europe)

California Best Management Practices Regulations for Perchlorate Materials:

This Perchlorate warning applies only to products containing CR (Manganese Dioxide) Lithium coin cells. "Perchlorate Material-special handling may apply. See [www.dtsc.ca.gov/hazardouswaste/perchlorate](http://www.dtsc.ca.gov/hazardouswaste/perchlorate)"

## Notes

(continued from front)

The products sold by Supermicro are not intended for and will not be used in life support systems, medical equipment, nuclear facilities or systems, aircraft, aircraft devices, aircraft/emergency communication devices or other critical systems whose failure to perform be reasonably expected to result in significant injury or loss of life or catastrophic property damage. Accordingly, Supermicro disclaims any and all liability, and should buyer use or sell such products for use in such ultra-hazardous applications, it does so entirely at its own risk. Furthermore, buyer agrees to fully indemnify, defend and hold Supermicro harmless for and against any and all claims, demands, actions, litigation, and proceedings of any kind arising out of or related to such ultra-hazardous use or sale.