

SUPERO®

SC815 Chassis Series

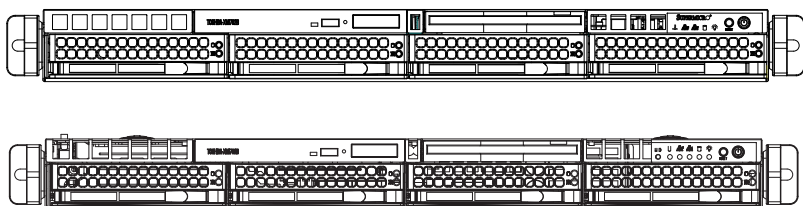

SC815TQ-720CB

SC815TQ-720UB

SC815TQ-710(V)(B)

SC815TQ-710U(B)

SC815TQ-710C(V)(B)

SC815S-700(V)(B)

SC815TQ-700(V)(B)

SC815S-700C(V)(B)

SC815TQ-700C(V)(B)

SC815S-R650C(V)(B)

SC815TQ-R650C(V)(B)

SC815S-560(V)(B)

SC815TQ-560(V)(B)

SC815S-560C(V)(B)

SC815TQ-560C(V)(B)

SC815TQ-R450U(V)(B)

SC815TQ-R650U(V)(B)

SC815TQ-560U(V)(B)

USER'S MANUAL

The information in this User's Manual has been carefully reviewed and is believed to be accurate. The vendor assumes no responsibility for any inaccuracies that may be contained in this document, makes no commitment to update or to keep current the information in this manual, or to notify any person or organization of the updates. **Please Note: For the most up-to-date version of this manual, please see our web site at www.supermicro.com.**

Super Micro Computer, Inc. ("Supermicro") reserves the right to make changes to the product described in this manual at any time and without notice. This product, including software, if any, and documentation may not, in whole or in part, be copied, photocopied, reproduced, translated or reduced to any medium or machine without prior written consent.

IN NO EVENT WILL SUPERMICRO BE LIABLE FOR DIRECT, INDIRECT, SPECIAL, INCIDENTAL, SPECULATIVE OR CONSEQUENTIAL DAMAGES ARISING FROM THE USE OR INABILITY TO USE THIS PRODUCT OR DOCUMENTATION, EVEN IF ADVISED OF THE POSSIBILITY OF SUCH DAMAGES. IN PARTICULAR, SUPERMICRO SHALL NOT HAVE LIABILITY FOR ANY HARDWARE, SOFTWARE, OR DATA STORED OR USED WITH THE PRODUCT, INCLUDING THE COSTS OF REPAIRING, REPLACING, INTEGRATING, INSTALLING OR RECOVERING SUCH HARDWARE, SOFTWARE, OR DATA.

Any disputes arising between manufacturer and customer shall be governed by the laws of Santa Clara County in the State of California, USA. The State of California, County of Santa Clara shall be the exclusive venue for the resolution of any such disputes. Super Micro's total liability for all claims will not exceed the price paid for the hardware product.

California Best Management Practices Regulations for Perchlorate Materials: This Perchlorate warning applies only to products containing CR (Manganese Dioxide) Lithium coin cells. "Perchlorate Material-special handling may apply. See www.dtsc.ca.gov/hazardouswaste/perchlorate"

WARNING: Handling of lead solder materials used in this product may expose you to lead, a chemical known to the State of California to cause birth defects and other reproductive harm.

Manual Revision 1.1a
Release Date: November 18, 2009

Unless you request and receive written permission from Super Micro Computer, Inc., you may not copy any part of this document.

Information in this document is subject to change without notice. Other products and companies referred to herein are trademarks or registered trademarks of their respective companies or mark holders.

Copyright © 2009 by Super Micro Computer, Inc.
All rights reserved.

Printed in the United States of America

Preface

About This Manual

This manual is written for professional system integrators and PC technicians. It provides information for the installation and use of the SC815 1U chassis. Installation and maintenance should be performed by experienced technicians only.

Supermicro's SC815 1U chassis features a unique and highly-optimized design for Xeon and Opteron platforms. The chassis is equipped with a 450W, 560W, 650W 700W or 710W high efficiency power supply, or Gold Level 720W system for superb power savings. High-performance fans provide ample optimized cooling, latest generation memory modules and 4 hot-swappable 3.5" drive bays offers maximum storage capacity in a 1U form factor. Optional LCD front bezels are also available for customization requirements. Bulk package and quick release slide rails are available for HPC and datacenter use.

This document lists compatible parts available when this document was published. Always refer to the our Web site for updates on supported parts and configurations.

Manual Organization

Chapter 1: Introduction

The first chapter provides a checklist of the main components included with this chassis and describes the main features of the SC815 chassis. This chapter also includes contact information.

Chapter 2: System Safety

This chapter lists warnings, precautions, and system safety. You should thoroughly familiarize yourself with this chapter for a general overview of safety precautions that should be followed before installing and servicing this chassis.

Chapter 3: Chassis Components

Refer here for details on this chassis model including the fans, bays, airflow shields, and other components.

Chapter 4: System Interface

Refer to this chapter for details on the system interface, which includes the functions and information provided by the control panel on the chassis as well as other LEDs located throughout the system.

Chapter 5: Chassis Setup and Installation

Refer to this chapter for detailed information on this chassis. You should follow the procedures given in this chapter when installing, removing, or reconfiguring your chassis.

Chapter 6: Rack Installation

Refer to this chapter for detailed information on chassis rack installation. You should follow the procedures given in this chapter when installing, removing or reconfiguring your chassis into a rack environment.

Appendices

This section lists compatible cables, power supply specifications, and compatible backplanes. Not all compatible backplanes are listed. Refer to our Web site for the latest compatible backplane information.

Appendix A: Chassis Cables

Appendix C: Power Supply Specifications

Appendix C: SAS-815TQ Backplane Specifications

Appendix D: SCA-813S Backplane Specifications

Table of Contents

Preface

About This Manual	iii
-------------------------	-----

Chapter 1 Introduction

1-1 Overview	1-1
1-2 Shipping List.....	1-1
1-3 Chassis Features	1-3
CPU.....	1-3
Hard Drives	1-3
I/O Expansion slots	1-3
Peripheral Drives.....	1-3
Other Features	1-3
1-4 Contacting Supermicro.....	1-4
1-5 Returning Merchandise for Service.....	1-5

Chapter 2 System Safety

2-1 Overview	2-1
2-2 Warnings and Precautions	2-1
2-3 Preparing for Setup.....	2-1
2-4 Electrical Safety Precautions	2-2
2-5 General Safety Precautions	2-3
2-6 System Safety	2-3

Chapter 3 Chassis Components

3-1 Overview	3-1
3-2 Components	3-1
Chassis.....	3-1
Backplane.....	3-1
Fans	3-1
Mounting Rails	3-1
Power Supply	3-2
Air Shroud	3-2
3-3 Where to get Replacement Components.....	3-2

Chapter 4 System Interface

4-1 Overview	4-1
4-2 Control Panel Buttons	4-2
4-3 Control Panel LEDs	4-3
4-4 Drive Carrier LEDs.....	4-4
SAS/SATA Drives	4-4

	SCSI Drives.....	4-5
4-5	Power Supply LEDs and Overheat Indicators.....	4-5
	450W and 650W Power Supplies.....	4-5
	All Other Power Supplies.....	4-6
4-6	Overheating.....	4-6

Chapter 5 Chassis Setup and Maintenance

5-1	Overview.....	5-1
5-2	Installation Procedures.....	5-1
	General Maintenance.....	5-1
5-3	Removing the Chassis Cover and Front Bezel.....	5-2
	The Front Bezel.....	5-3
5-4	Installing Hard Drives.....	5-4
5-5	DVD and Floppy Drive Installation.....	5-7
5-6	Installing the Motherboard.....	5-8
	Permanent and Optional Standoffs.....	5-8
	Expansion Card Setup.....	5-10
5-7	Installing the Air Shroud.....	5-12
5-8	System Fans.....	5-14
5-9	Power Supply.....	5-16
	Power Supply Failure.....	5-16
5-10	Routing the I ² C Cables.....	5-18

Chapter 6 Rack Installation

6-1	Overview.....	6-1
6-2	Unpacking the System.....	6-1
6-3	Preparing for Setup.....	6-1
	Choosing a Setup Location.....	6-1
	Rack Precautions.....	6-2
	General Server Precautions.....	6-2
	Rack Mounting Considerations.....	6-3
	Ambient Operating Temperature.....	6-3
	Reduced Airflow.....	6-3
	Mechanical Loading.....	6-3
	Circuit Overloading.....	6-3
	Reliable Ground.....	6-3
6-4	Rack Mounting Instructions.....	6-4
	Identifying the Sections of the Rack Rails.....	6-4
	Inner Rail Extension.....	6-5
	Installing the Chassis into a Telco rack.....	6-9

Appendix A Chassis Cables

Appendix B SC815 Power Supply Specifications

Appendix C SAS-815TQ Backplane Specifications

Appendix D SCA-813S Backplane Specifications

Notes

Chapter 1

Introduction

1-1 Overview

Supermicro's SC815 1U chassis features a unique and highly-optimized design. The chassis is equipped with a high efficiency power supply. High performance fans provide ample optimized cooling for FB-DIMM memory modules and four hot-swap drive bays offer maximum storage capacity in a 1U form factor.

1-2 Shipping List

Please visit the following link for the latest shipping lists and part numbers for your particular chassis model <http://www.supermicro.com/products/chassis/1U/?chs=815>

SC815 Chassis				
Model	CPU	HDD	I/O Slots	Power Supply
SC815TQ-720UB	DP/UP Xeon/AMD	4x SAS / SATA	1xFF	720W (Gold Level)
SC815TQ-720CB	DP/UP Xeon/AMD	4x SAS / SATA	1xFF, 1xLP, 1 UIO	720W (Gold Level)
• SC815TQ-710UB	DP/UP Xeon/AMD	4x SAS / SATA	2x FH, 1x LP	710W (DC)
• SC815TQ-710V / SC815TQ-710B	DP/UP Xeon/AMD	4x SAS / SATA	1x FF, 1x LP	710W (DC)
• SC815S-710CV / SC815S-710CB	DP/UP Xeon/AMD	4x U320 SCSI	1x FF	710W (DC)
• SC815TQ-700V / SC815TQ-700B	DP/UP Xeon/AMD	4x SAS / SATA	1x FF, 1x LP	700W
• SC815TQ-700CV / SC815TQ-700CB	DP/UP Xeon/AMD	4x SAS / SATA	1x FF	700W
• SC815S-700V / SC815S-700B	DP/UP Xeon/AMD	4x U320 SCSI	1x FF, 1x LP	700W
• SC815S-700CV / SC815S-700CB	DP/UP Xeon/AMD	4x U320 SCSI	1x FF	700W
• SC815TQ-R650UV / SC815TQ-R650UB	DP/UP Xeon/AMD	4x SAS / SATA	2x FH, 1x LP	650W (Redundant)

SC815 Chassis				
• SC815TQ-R650V / SC815TQ-R650B	DP/UP Xeon/AMD	4x SAS / SATA	1x FF, 1x LP	650W (Redundant)
• SC815S-R650V / SC815S-R650B	DP/UP Xeon/AMD	4x U320 SCSI	1x FF	650W (Redundant)
• SC815TQ-560UV / SC815TQ-560UB	DP/UP Xeon/AMD	4x SAS / SATA	2x FH, 1x LP	560W
• SC815TQ-560V / SC815TQ-560B	DP/UP Xeon/AMD	4x SAS / SATA	1x FF, 1x LP	560W
• SC815TQ-560CV / SC815TQ-560CB	DP/UP Xeon/AMD	4x SAS / SATA	1x FF	560W
• SC815S-560V / SC815S-560B	DP/UP Xeon/AMD	4x U320 SCSI	1x FF, 1x LF	560W
• SC815S-560CV / SC815S-560CB	DP/UP Xeon/AMD	4x U320 SCSI	1x FF	560W
• SC815TQ-R450UV / SC815TQ-R450UB	DP/UP Xeon/AMD	4x SAS / SATA	2x FH, 1x LP	450W (Redundant)

1-3 Chassis Features

The SC815 1U high performance chassis includes the following features:

CPU

The SC815 chassis supports a DP or UP Dual-core Xeon processor. Please refer to the motherboard specifications pages on our website for updates on supported processors.

Hard Drives

The SC815 chassis features four slots for U320 SCSI or SAS/SATA drives. These drives are hot swappable. Once setup correctly, these drives can be removed without powering down the server. In addition, these drives support SAF-TE (SCSI) or SES2 (SAS/SATA).

I/O Expansion slots

Each version of the SC815 chassis includes one full I/O expansion slot and one low profile I/O slot. "C" versions include only the full I/O expansion slot. "U" versions are optimized for UIO mother boards and include two full I/O expansion slots and one low profile expansion slot.

Peripheral Drives

Each SC815 chassis supports one slim DVD-ROM Drive (included) and one slim floppy drive (optional). These drives allow you to quickly install or save data. Both DVD drive and floppy drives are optional in 560W models.

Other Features

Other onboard features are included to promote system health. These include various four cooling fans, a convenient power switch, reset button, and five LED indicators.

1-4 Contacting Supermicro

Headquarters

Address: Super Micro Computer, Inc.
980 Rock Ave.
San Jose, CA 95131 U.S.A.

Tel: +1 (408) 503-8000

Fax: +1 (408) 503-8008

Email: marketing@supermicro.com (General Information)
support@supermicro.com (Technical Support)

Web Site: www.supermicro.com

Europe

Address: Super Micro Computer B.V.
Het Sterrenbeeld 28, 5215 ML
's-Hertogenbosch, The Netherlands

Tel: +31 (0) 73-6400390

Fax: +31 (0) 73-6416525

Email: sales@supermicro.nl (General Information)
support@supermicro.nl (Technical Support)
rma@supermicro.nl (Customer Support)

Asia-Pacific

Address: Super Micro Computer, Inc.
4F, No. 232-1, Liancheng Rd.
Chung-Ho 235, Taipei County
Taiwan, R.O.C.

Tel: +886-(2) 8226-3990

Fax: +886-(2) 8226-3991

Web Site: www.supermicro.com.tw

Technical Support:

Email: support@supermicro.com.tw

Tel: 886-2-8226-1900

1-5 Returning Merchandise for Service

A receipt or copy of your invoice marked with the date of purchase is required before any warranty service will be rendered. You can obtain service by calling your vendor for a Returned Merchandise Authorization (RMA) number. When returning to the manufacturer, the RMA number should be prominently displayed on the outside of the shipping carton, and mailed prepaid or hand-carried. Shipping and handling charges will be applied for all orders that must be mailed when service is complete.

For faster service, RMA authorizations may be requested online (<http://www.supermicro.com/support/rma/>).

Whenever possible, repack the chassis in the original Supermicro carton, using the original packaging material. If these are no longer available, be sure to pack the chassis securely, using packaging material to surround the chassis so that it does not shift within the carton and become damaged during shipping.

This warranty only covers normal consumer use and does not cover damages incurred in shipping or from failure due to the alteration, misuse, abuse or improper maintenance of products.

During the warranty period, contact your distributor first for any product problems.

Notes

Chapter 2

System Safety

2-1 Overview

This chapter provides a quick setup checklist to get your chassis up and running. Following the steps in order given should enable you to have your chassis setup and operational within a minimal amount of time. This quick set-up assumes that you are an experienced technician, familiar with common concepts and terminology.

2-2 Warnings and Precautions

You should inspect the box the chassis was shipped in and note if it was damaged in any way. If the chassis itself shows damage, file a damage claim with carrier who delivered your system.

Decide on a suitable location for the rack unit that will hold that chassis. It should be situated in a clean, dust-free area that is well ventilated. Avoid areas where heat, electrical noise and electromagnetic fields are generated.

You will also need it placed near at least one grounded power outlet. When configured, the SC815 chassis includes one power supply. "R" models include a redundant power supply and require two grounded outlets.

2-3 Preparing for Setup

The SC815 chassis includes a set of rail assemblies, including mounting brackets and mounting screws you will need to install the systems into the rack. Please read this manual in its entirety before you begin the installation procedure.

2-4 Electrical Safety Precautions

Basic electrical safety precautions should be followed to protect yourself from harm and the SC815 from damage:

- Be aware of the locations of the power on/off switch on the chassis as well as the room's emergency power-off switch, disconnection switch or electrical outlet. If an electrical accident occurs, you can then quickly remove power from the system.
- Do not work alone when working with high-voltage components.
- Power should always be disconnected from the system when removing or installing main system components, such as the serverboard, memory modules and the DVD-ROM and floppy drives (not necessary for hot swappable drives). When disconnecting power, you should first power down the system with the operating system and then unplug the power cords from all the power supply modules in the system.
- When working around exposed electrical circuits, another person who is familiar with the power-off controls should be nearby to switch off the power, if necessary.
- Use only one hand when working with powered-on electrical equipment. This is to avoid making a complete circuit, which will cause electrical shock. Use extreme caution when using metal tools, which can easily damage any electrical components or circuit boards they come into contact with.
- Do not use mats designed to decrease electrostatic discharge as protection from electrical shock. Instead, use rubber mats that have been specifically designed as electrical insulators.
- The power supply power cord must include a grounding plug and must be plugged into grounded electrical outlets.
- Serverboard Battery: CAUTION - There is a danger of explosion if the onboard battery is installed upside down, which will reverse its polarities. This battery must be replaced only with the same or an equivalent type recommended by the manufacturer. Dispose of used batteries according to the manufacturer's instructions.
- DVD-ROM laser: CAUTION - this server may have come equipped with a DVD-ROM drive. To prevent direct exposure to the laser beam and hazardous

radiation exposure, do not open the enclosure or use the unit in any unconventional way.

2-5 General Safety Precautions

- Keep the area around the chassis clean and free of clutter.
- Place the chassis top cover and any system components that have been removed away from the system or on a table so that they won't accidentally be stepped on.
- While working on the system, do not wear loose clothing such as neckties and unbuttoned shirt sleeves, which can come into contact with electrical circuits or be pulled into a cooling fan.
- Remove any jewelry or metal objects from your body, which are excellent metal conductors that can create short circuits and harm you if they come into contact with printed circuit boards or areas where power is present.
- After accessing the inside of the system, close the system back up and secure it to the rack unit with the retention screws after ensuring that all connections have been made.

2-6 System Safety

Electrostatic discharge (ESD) is generated by two objects with different electrical charges coming into contact with each other. An electrical discharge is created to neutralize this difference, which can damage electronic components and printed circuit boards. The following measures are generally sufficient to neutralize this difference before contact is made to protect your equipment from ESD:

- Do not use mats designed to decrease electrostatic discharge as protection from electrical shock. Instead, use rubber mats that have been specifically designed as electrical insulators.
- Use a grounded wrist strap designed to prevent static discharge.
- Keep all components and printed circuit boards (PCBs) in their antistatic bags until ready for use.

- Touch a grounded metal object before removing any board from its antistatic bag.
- Do not let components or PCBs come into contact with your clothing, which may retain a charge even if you are wearing a wrist strap.
- Handle a board by its edges only; do not touch its components, peripheral chips, memory modules or contacts.
- When handling chips or modules, avoid touching their pins.
- Put the serverboard and peripherals back into their antistatic bags when not in use.
- For grounding purposes, make sure your computer chassis provides excellent conductivity between the power supply, the case, the mounting fasteners and the serverboard.

Chapter 3

Chassis Components

3-1 Overview

This chapter describes the most common components included with your chassis. Some components listed may not be included or compatible with your particular chassis model. For more information, see the installation instructions detailed later in this manual.

3-2 Components

Chassis

Chassis include one slim CD-ROM bay, one slim floppy disc drive bay, and/or four hard drive bays. Most chassis models include a DVD-ROM. Floppy disk drives and hard drives must be purchased separately. For the latest shipping lists, visit our Web site at: <http://www.supermicro.com>.

This chassis accepts a 1U backplane, four fans (with an optional fifth fan) and one (sometimes two) power supplies. SC815 models come in silver and black.

Backplane

Each SC815 chassis comes with a 1U backplane. Depending on our order, your backplane will accept SAS/SATA or SCSI. For more information regarding compatible backplanes, view the appendices found at the end of this manual. In addition, visit our Web site for the latest information: <http://www.supermicro.com>.

Fans

The SC815 chassis accepts four system fans with an optional fifth fan. System fans for SC815 chassis are powered from the serverboard. These fans are 1U high and are powered by 3-pin connectors.

Mounting Rails

The SC815 can be placed in a rack for secure storage and use. To setup your rack, follow the step-by-step instructions included in this manual.

Power Supply

Each SC815 chassis model includes a high-efficiency power supply rated between 450, 560, 650, 700, 710 or 720 Watts. In the unlikely event that your power supply fails, replacement is simple and can be done without tools.

"R" model chassis include a redundant, hot-swappable power supply.

Air Shroud

Air shrouds are shields, usually plastic, that funnel air directly to where it is needed. Always use the air shroud included with your chassis.

3-3 Where to get Replacement Components

Though not frequently, you may need replacement parts for your system. To ensure the highest level of professional service and technical support, we strongly recommend purchasing exclusively from our Supermicro Authorized Distributors / System Integrators/Resellers. A list of Supermicro Authorized Distributors/System Integrators/Reseller can be found at: <http://www.supermicro.com>. Click the Where to Buy link.

Chapter 4

System Interface

4-1 Overview

There are several LEDs on the control panel and on the drive carriers that provide system and component status. This chapter explains the meanings of all LED indicators and the appropriate responses that need to be taken.

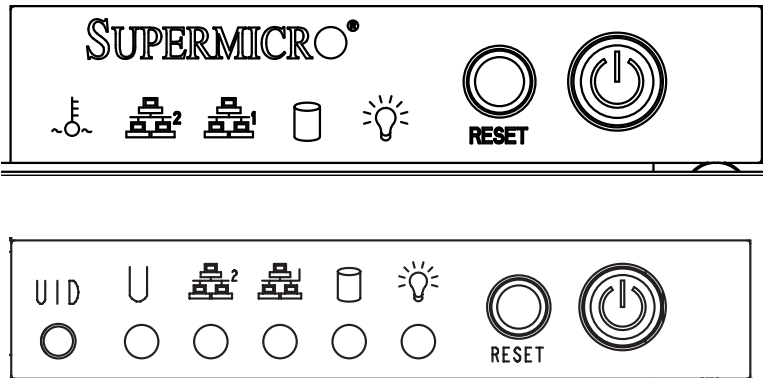
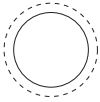

Figure 4-1. Control Panel Buttons and LEDs

4-2 Control Panel Buttons

The SC815 chassis includes two or three push-buttons located on the front panel: a reset button, a power on/off button, and a UID button



- **Reset:** The reset button is used to reboot the system.



- **Power:** The main power switch is used to apply or remove power from the power supply to the server system. Turning off system power with this button removes the main power but keeps standby power supplied to the system. Therefore, you must unplug system before servicing.

UID

- **UID:** When used with a UID-compatible motherboard, the UID button is used to turn on or off the blue light function of the the U-LED. Once the blue light is activated, the unit can be easily located in very large racks and server banks.

4-3 Control Panel LEDs

The control panel located on the front of the SC815 chassis has up to five LEDs. These LEDs provide critical information related to different parts of the system. This section explains what each LED indicates when illuminated and any action that may be required.



- **Universal Information LED:** The Universal Information LED is used to indicate fan failure, power failure, overheat condition, or to identify the unit within a large rack installation. The feature requires a motherboard that supports the Universal Information LED.

When this LED blinks red quickly, it indicates a fan failure and when blinking red slowly a power failure. This LED will be blue when used for UID (Unit Identifier). When on continuously red, it indicates an overheat condition, which may be caused by cables obstructing the airflow in the system or the ambient room temperature being too warm. See the table below for descriptions of the LED states.

Universal Information LED States	
State	Indication
Fast Blinking Red (1x/sec)	Fan Fail
Solid Red	CPU Overheat
Slow Blinking Red (1x/4 sec)	Power Fail
Solid Blue	Local UID Button Depressed
Blinking Blue	IPMI-Activated UID

Figure 4-2: Universal Information LED States

Note: Deactivating the UID LED must be performed in the same way it was activated. (If the UID LED was activated via IPMI, you can only turn the LED off via IPMI and not with the UID button.)



- **Overheat/Fan Fail:** When this LED flashes it indicates a fan failure. When continuously on (not flashing) it indicates an overheat condition, which may be caused by cables obstructing the airflow in the system or the ambient room temperature being too warm.



- NIC2: Indicates network activity on GLAN2 when flashing.



- NIC1: Indicates network activity on GLAN1 when flashing.



- HDD: Indicates IDE channel activity. SAS/SATA drive, SCSI drive, and/or DVD-ROM drive activity when flashing.



- Power: Indicates power is being supplied to the system's power supply units. This LED should normally be illuminated when the system is operating.

4-4 Drive Carrier LEDs

Your chassis uses SAS/SATA or SCSI drives, but not both.

SAS/SATA Drives

Each SAS/SATA drive carrier has two LEDs.

- Green: Each Serial ATA drive carrier has a green LED. When illuminated, this green LED (on the front of the SATA drive carrier) indicates drive activity. A con-

nection to the SATA backplane enables this LED to blink on and off when that particular drive is being accessed.

- Red: The red LED to indicate an SAS/SATA drive failure. If one of the SAS/SATA drives fail, you should be notified by your system management software.

SCSI Drives

Each SCSI drive carrier has two LEDs.

- Green: When illuminated, the green LED on the front of the SCSI drive carrier indicates drive activity. A connection to the SCSI SCA backplane enables this LED to blink on and off when that particular drive is being accessed.
- Red: The SAF-TE compliant backplane activates the red LED to indicate a drive failure. If one of the SCSI drives fail, you should be notified by your system management software.

4-5 Power Supply LEDs and Overheat Indicators

This chassis provides several options which may include hot-swappable, cold-swappable, and redundant power supplies. Some power supplies include an LED in the rear with the following definitions:

450W and 650W Power Supplies

450W and 650W Power Supply LEDs	
State	Indication
Solid Green	System is on.
Solid Amber	System is off and plugged in.
Blinking Amber	Internal temperature has reached 63C and will shut down if the temperature reaches 70C.

- Solid Green: When illuminated, the green LED indicates that the power supply is on.
- Solid Amber: When illuminated, the amber LED indicates the power supply is plugged in and turned off, or the system is off but in an abnormal state.

- **Blinking Amber:** When blinking, this system power supply temperature has reached to 63C. The system automatically power down when the power supply temperature reaches 70C and restarts when the power supply temperature goes below 60C.

All Other Power Supplies

- **Solid Green:** When illuminated, this green LED indicates that the power supply is on.

All Other Power Supply LEDs	
State	Indication
Solid Green	System is on.
Solid Amber	System is off and plugged in.

- **Solid Amber:** When illuminated, the amber LED indicates the power supply is plugged in and turned off, or the system is off but in an abnormal state.

4-6 Overheating

The section lists actions that should be taken in the unlikely event the server overheats.

Overheat Temperature Setting

Some backplanes allow the overheat temperature to be set at 45, 50, or 55 by changing a jumper setting. For more information, download the backplane user manual at www.supermicro.com. To access the manuals on the Website, click support, and then click the manuals link.

Overheating Condition

If the Server Overheats, do the Following:

1. Use the LEDs to determine the nature of the overheating condition.

2. Confirm that the chassis covers are installed properly.
3. Check the routing of the cables and make sure all fans are present and operating normally.
4. Verify that the heatsinks are installed properly.

Notes

Chapter 5

Chassis Setup and Maintenance

5-1 Overview

This chapter covers the steps required to install components and perform maintenance on the chassis. The only tool you will need to install components and perform maintenance is a Phillips screwdriver. Print this page to use as a reference while setting up your chassis.

5-2 Installation Procedures

Removing the Chassis Cover and Front Bezel

Installing Hard Drives

DVD and Floppy Drive Installation

Installing the Motherboard (includes U I/O Slot Setup)

Installing the Air Shroud and Check Airflow

General Maintenance

General Maintenance: Systems Fans

General Maintenance: Replace Power Supply



Review the warnings and precautions listed in the manual before setting up or servicing this chassis. These include information in Chapter 2: System Safety and the warning/precautions listed in the setup instructions.

5-3 Removing the Chassis Cover and Front Bezel

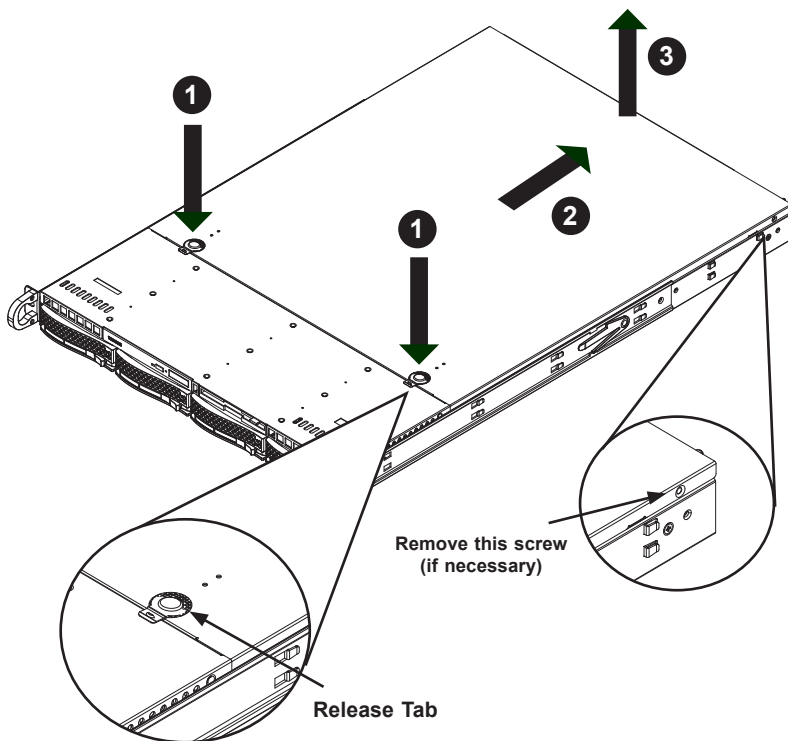

Figure 5-1: Removing the Chassis Cover

Removing the Chassis Cover

1. Press the release tabs to remove the cover from the locked position. Press both tabs at the same time.
2. Once the top cover is released from the locked position, slide the cover toward the rear of the chassis.
3. Lift the cover off the chassis.



Warning: Except for short periods of time, do NOT operate the server without the cover in place. The chassis cover must be in place to allow proper airflow and prevent overheating.

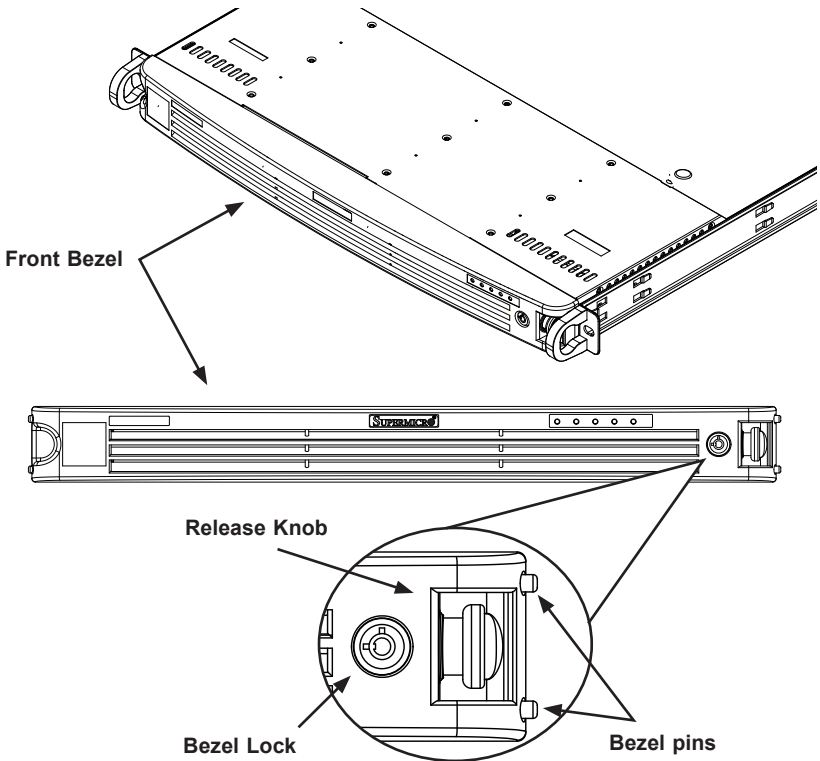

Figure 5-2: Removing the Front Bezel

The Front Bezel

If your system has an optional front bezel attached to the chassis, you must remove it to access the drive bays. A filter located within the bezel can be removed for cleaning or replacement. It is recommended that you keep a maintenance log and frequently replace the filter. The filter's condition will affect the airflow throughout the whole system.

Removing the Front Bezel

1. Unlock the bezel lock.
2. Press the release knob to retract the bezel pins
3. Carefully remove the bezel with both hands.

5-4 Installing Hard Drives

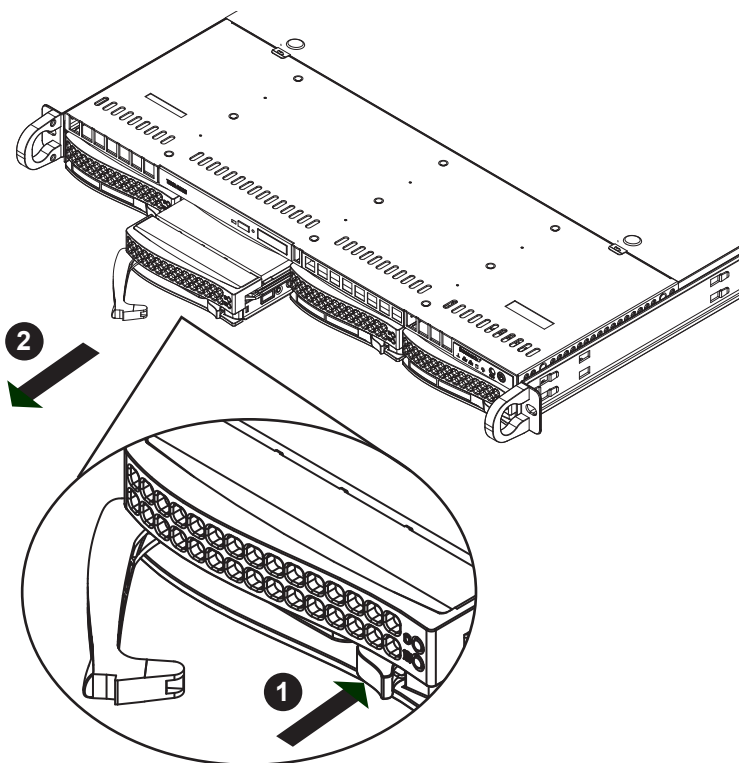

Figure 5-3: Removing Hard Drive Carriers

Removing Hard Drive Carriers from the Chassis

1. Press the release button on the drive carrier. This extends the drive carrier handle.
2. Use the handle to pull the drive carrier out of the chassis.

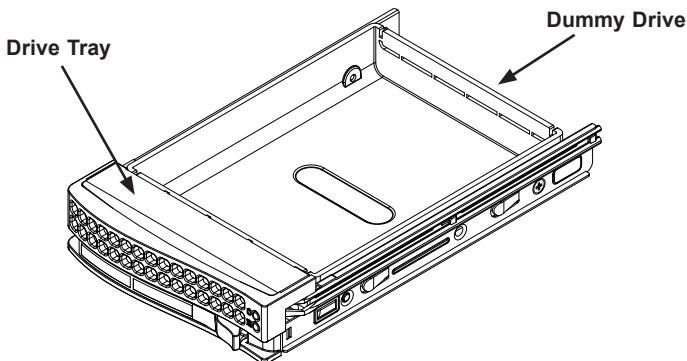

Figure 5-4: Chassis Drive Carrier

The drives are mounted in drive carriers to simplify their installation and removal from the chassis. These carriers also help promote proper airflow for the drive bays.



Warning: Except for short periods of time (swapping hard drives), do not operate the chassis without the drive carriers.

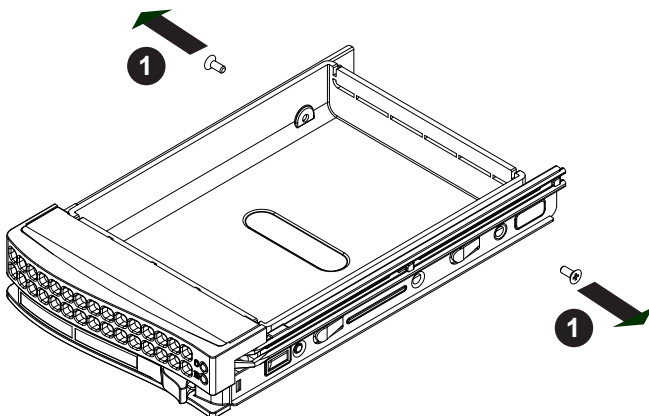

Figure 5-5: Removing a Dummy Drive from the Carrier

Installing a Hard Drive to the Hard Drive Carrier

1. Remove the screws (2) securing the dummy drive to the carrier.
2. Remove the dummy drive from the carrier.

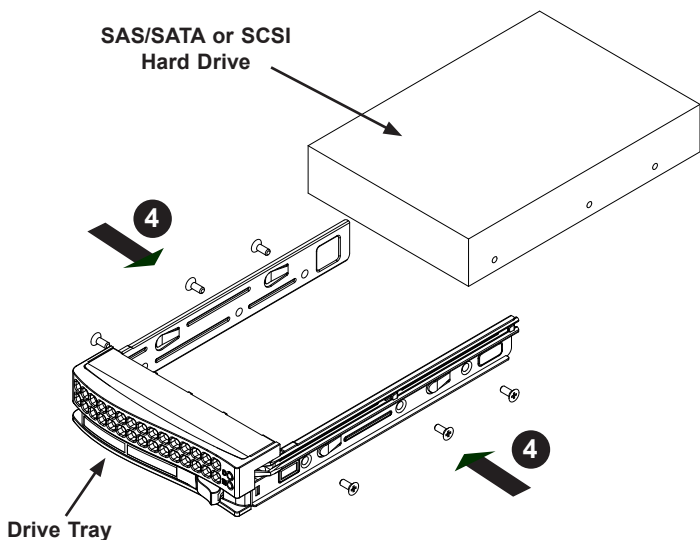

Figure 5-6: Removing the Hard Drive From the Carrier

3. Install a new drive into the carrier with the printed circuit board side facing down so that the mounting holes align with those in the carrier.
4. Secure the hard drive by tightening all six (6) screws.
5. Replace the drive tray into the chassis. Make sure the close the drive carrier handle.

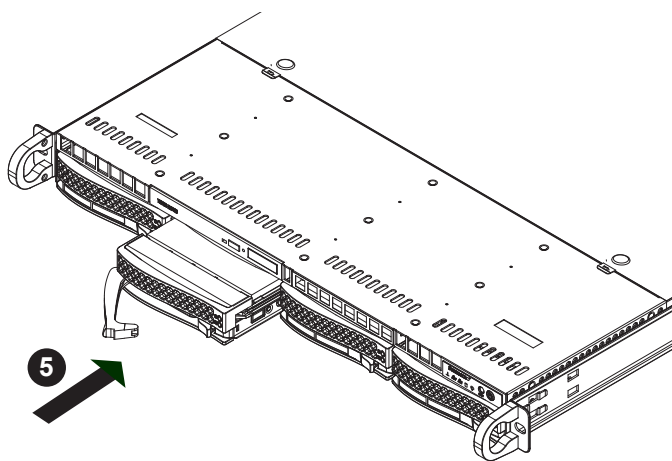

Figure 5-7: Replacing the Hard Drive Carrier

5-5 DVD and Floppy Drive Installation

Most SC815 chassis models include a DVD-ROM and space for an optional floppy drive. The DVD-ROM is usually pre-installed.

Installing or Replacing a DVD-ROM or Floppy Drive

1. Power down the system and if necessary, remove the server from the rack and the front bezel from the chassis.
2. Remove the chassis cover.
3. Unplug the drives power and data cables from the motherboard and/or back-plane.
4. If you are adding a new drive: Remove the mini-bezel (grate) from the drive bay. The bezel can be removed by pulling out the hard drive beneath the DVD-ROM or floppy drive bay, then pulling the mini-bezel forward.
If you are replacing a drive: Locate the locking tab at the rear (left hand side when viewed from the front) of the DVD-ROM or floppy drive. Push the tab toward the drive and push the drive unit out the front of the chassis.
5. Insert the new drive unit in the slot until the tab locks in place.
6. Reconnect the data and power cables.
7. Replace the chassis cover (replace the server in the rack, if necessary) and power up the system.

5-6 Installing the Motherboard

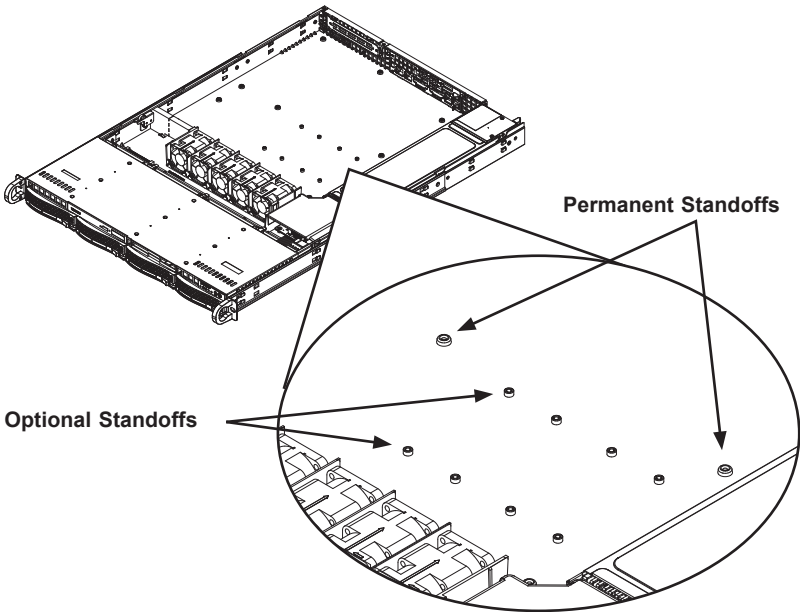

Figure 5-8: Chassis Standoffs

Permanent and Optional Standoffs

Standoffs prevent short circuits by securing space between the motherboard and the chassis surface. The SC815 chassis includes permanent standoffs in locations used by most motherboards. These standoffs accept the rounded Phillips head screws included in the SC815 accessories packaging.

Some motherboards require additional screws for heatsinks and/or general components. Optional standoffs are included for these motherboards. To use an optional standoff, you must place the hexagonal screw through the bottom the chassis and secure the screw with the hexagonal nut (rounded side up).

Installing the Motherboard

1. Review the documentation that came with your motherboard. Become familiar with component placement, requirements, and precautions.
2. Disconnect the power supply and lay the chassis on a flat surface.
3. Open the chassis cover.
4. If necessary, remove the riser card. To do this, remove the two screws holding the card in place and lift the card from the chassis.
5. As required by your motherboard, install standoffs in any areas that do not have a permanent standoff:
 - A. Place a hexagonal standoff screw through the bottom the chassis.
 - B. Secure the screw with the hexagonal nut (rounded side up).
6. Lay the motherboard on the chassis aligning the permanent and optional standoffs
7. Secure the motherboard to the chassis using the rounded, Phillips head screws. Do not exceed eight pounds of torque per square inch, when tightening down the motherboard.
8. Secure the CPU(s), heatsinks, and other components to the motherboard, chassis, and/or backplane as needed.

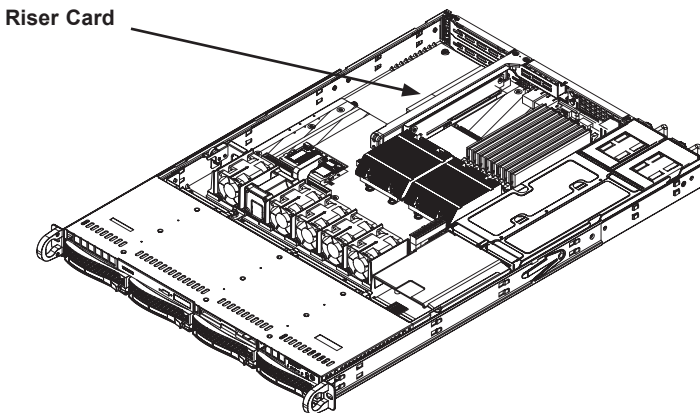

Figure 5-9: Chassis with a Riser Card ("U" Models Only)

Expansion Card Setup

SC815 chassis include I/O slots for add-on cards and expansion cards. "C" models (like SC815TQ-700CV) include one full width slot. SC815 "U" model chassis include two full-height/full length expansion slots and one low-profile expansion slot. Other models (non-Universal IO) include one full-height/full length expansion slot and one low-profile slot.

Note: You must use a riser card to install expansion cards to any SC815 chassis. Riser cards are sold separately.

For the latest compatibility and performance information visit our website at: <http://www.supernmicro.com>.

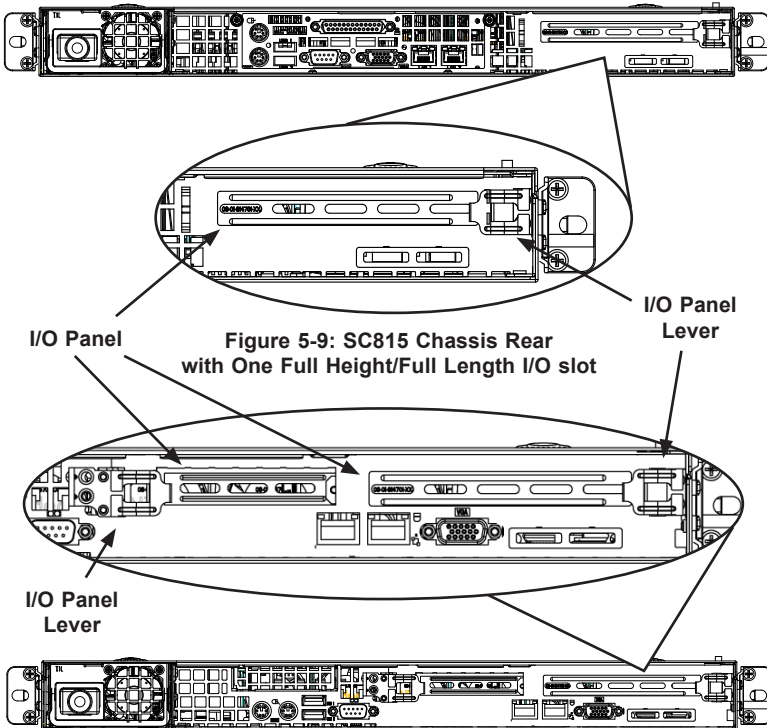

Figure 5-9: SC815 Chassis Rear with One Full Height/Full Length I/O slot

Figure 5-10: SC815 Chassis Rear with One Full Height/Full Length I/O slot and One Low Profile I/O slot

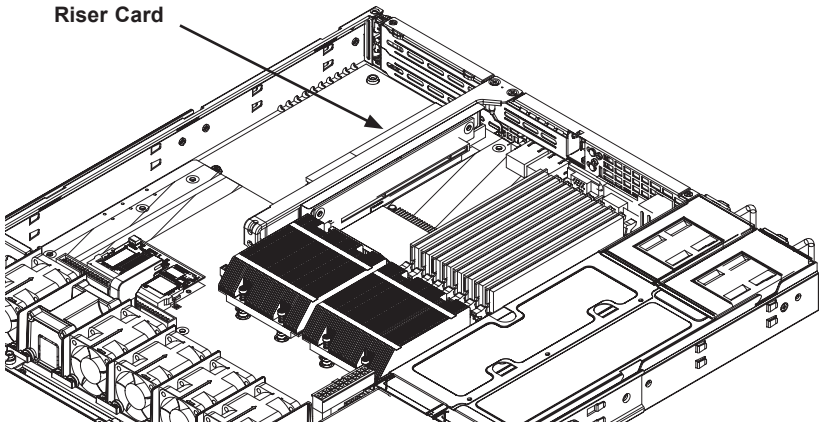

Figure 5-11: Chassis with a Riser Card ("U" Models Only)

Installing an Expansion Card

1. Confirm that you have the correct riser card for your chassis model and the add-on card includes a standard bracket.
2. Remove the chassis cover.
3. Install the riser card by sliding card into the appropriate slot in the motherboard. For more information, see the riser card installation instructions.
4. Choose the I/O panel in which to place the add-on card.
5. In that slot, open the I/O panel lever and slide the I/O panel sideways.
6. From inside the chassis, remove the I/O panel.
7. Slide the add-on card into the riser card and attach the add-on card bracket in place of the I/O panel.
8. Secure the add-on card by closing the I/O panel lever.
9. Connect cables to the add-on card as necessary.

5-7 Installing the Air Shroud

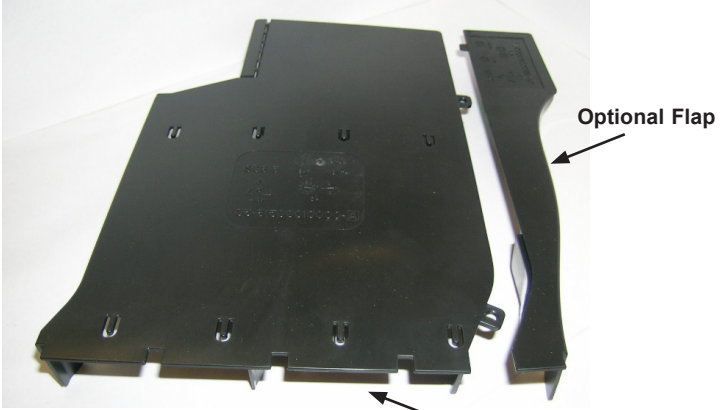

Figure 5-11: Air Shroud Front (Fan Side)

Air shrouds concentrate airflow to maximize fan efficiency. The SC815 chassis air shroud does not require screws to set up.

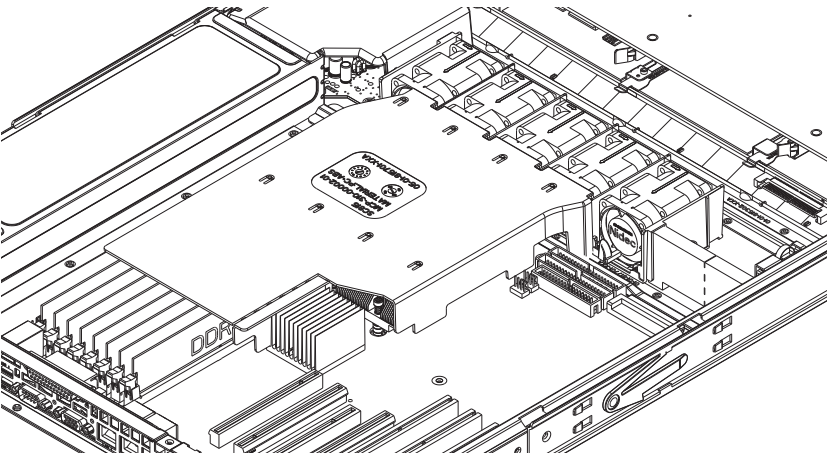

Figure 5-12: Air Shroud with the Optional Flap Removed

Installing the Air Shroud

1. Remove the chassis cover.
2. If your motherboard uses between 9 and 16 DIMMS, skip this step. If your motherboard uses 8 DIMMS, you must remove the optional flap. To do so:
 - a. With the fan side facing you, hold the air shroud with your left hand on the main shroud component and right hand on the optional flap.
 - b. Gently twist with your right hand by lifting the fan side and lowering the other end of the optional flap.
3. Place the air shroud in your chassis with the fan side touching the edge of the fans.
4. Replace the chassis cover.

Checking the Air Flow in the Chassis

1. Make sure there are no objects to obstruct airflow in and out of the chassis. In addition, if you are using a front bezel, make sure the bezel's filter is replaced periodically.
2. Do not operate the chassis without drive carriers in the drive bays. Use only recommended chassis parts.
3. Make sure no wires or foreign objects obstruct air flow through the chassis. Pull all excess cabling out of the airflow path or use shorter cables.
4. The control panel LEDs inform you of system status. See “Chapter 3: System Interface” for details on the LEDs and the control panel buttons.

5-8 System Fans



Figure 5-13: System Fan

Four heavy duty fans provide cooling for the chassis. These fans circulate air through the chassis as a means of lowering the chassis internal temperature.

In models with counter-rotating fans, each fan unit is actually made up of two fans joined back-to-back, which rotate in opposite directions. This counter-rotating action generates exceptional airflow and works to dampen vibration levels.

In chassis that provide an additional open fan housing, an additional system fan may be added for optimal cooling.

Adding a System Fan

1. Turn off the power to the system and unplug the system from the outlet.
2. Remove the dummy fan from the fan tray.
3. Place the new fan into the vacant space in the housing while making sure the arrows on the top of the fan (indicating air direction) point in the same direction as the arrows on the other fans.
4. Connect the fan wires to the fan headers on the serverboard.
5. Power up the system and check that the fan is working properly before replacing the chassis cover.

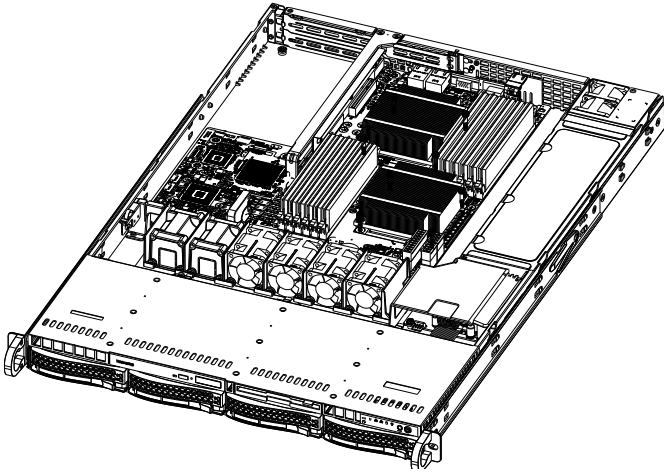

Figure 5-14: Chassis Fans
(Note additional fan options)

The SC815 chassis includes four pre-installed fans. One or two extra slots are available so that additional fans may be added.

Replacing a System Fan

1. If necessary, open the chassis while the power is running to determine which fan has failed. Never run the server for an extended period of time with the chassis open.
2. Turn off the power to the system and unplug the AC power cord from the outlet.
3. Remove the failed fan's wiring from the serverboard.
4. Lift the failed fan from the chassis and pull it completely out from the serverboard.
5. Place the new fan into the vacant space in the housing while making sure the arrows on the top of the fan (indicating air direction) point in the same direction as the arrows on the other fans.
6. Reconnect the fan wires to the exact same chassis fan headers as the previous fan.
7. Reconnect the AC power cord, power up the system and check that the fan is working properly before replacing the chassis cover.

5-9 Power Supply

Depending on your chassis model the SC815 Chassis has a 450, 560, 650, 700 710 or 720 Watt power supply. This power supply is auto-switching capable. The 450, 560, 650, 700 and 720 Watt power supplies automatically sense and operate at a 100V to 240V input voltage. The 710 DC power supply operates at -36DC to -75DC. An amber light will be illuminated on the power supply when the power is off. An illuminated green light indicates that the power supply is operating.

Power Supply Failure

If the power supply unit fails, the system will shut down and you will need to replace the unit. Replacement units can be ordered directly from Supermicro (see contact information in the Preface). As there is only one power supply unit in the SC815 Chassis, power must be completely removed from the server before removing and replacing the power supply unit for whatever reason.

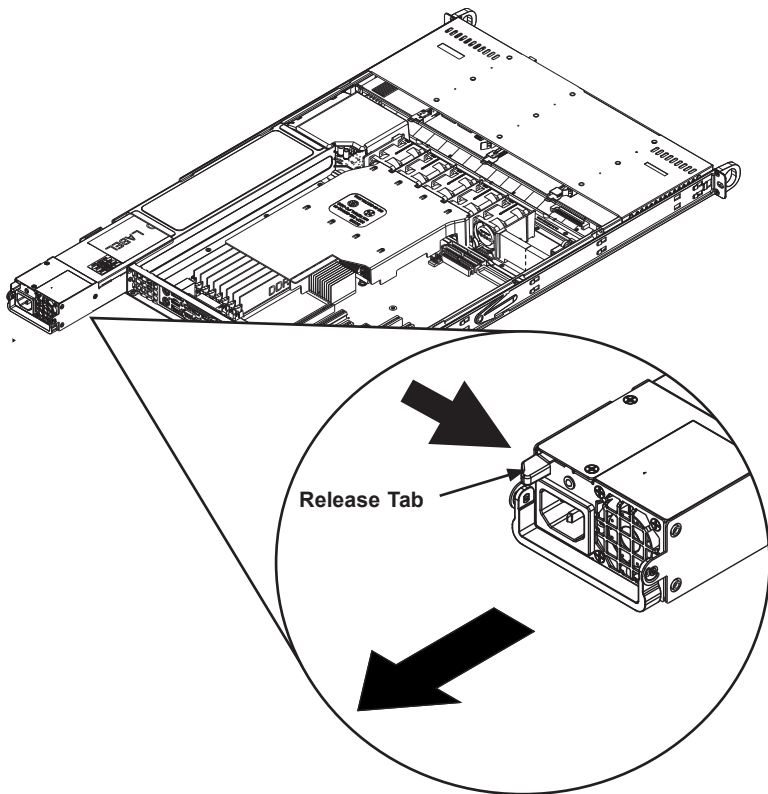

Figure 5-15: Removing the Power Supply

Replacing the Power Supply

1. Power down the server and unplug the power cord. If your chassis includes a redundant power supply (at least two power modules), you can leave the server running and remove only one power supply.
2. Push the release tab (on the back of the power supply) as illustrated.
3. Pull the power supply out using the handle provided.
4. Replace the failed power module with the same model.
5. Push the new power supply module into the power bay until you hear a click.
6. Plug the AC power cord back into the module and power up the server.

5-10 Routing the I²C Cables

It is necessary to correctly route the I²C cables to avoid interference due to noise on the I²C lines. Using tie wraps, secure the I²C cables to the large black power switching cable to keep it close to the power supply and away from the motherboard.

Chapter 6

Rack Installation

6-1 Overview

This chapter provides a quick setup checklist to get your chassis up and running. Following these steps in the order given should enable you to have the system operational within a minimum amount of time.

6-2 Unpacking the System

You should inspect the box the chassis was shipped in and note if it was damaged in any way. If the chassis itself shows damage you should file a damage claim with the carrier who delivered it.

Decide on a suitable location for the rack unit that will hold your chassis. It should be situated in a clean, dust-free area that is well ventilated. Avoid areas where heat, electrical noise and electromagnetic fields are generated. You will also need it placed near a grounded power outlet. Be sure to read the Rack and Server Precautions in the next section.

6-3 Preparing for Setup

The box your chassis was shipped in should include two sets of rail assemblies, two rail mounting brackets and the mounting screws you will need to install the system into the rack. Please read this section in its entirety before you begin the installation procedure outlined in the sections that follow.

Choosing a Setup Location

- Leave enough clearance in front of the rack to enable you to open the front door completely (~25 inches).
- Leave approximately 30 inches of clearance in the back of the rack to allow for sufficient airflow and ease in servicing.
- This product is for installation only in a Restricted Access Location (dedicated equipment rooms, service closets and the like).



Warnings and Precautions!



Rack Precautions

- Ensure that the leveling jacks on the bottom of the rack are fully extended to the floor with the full weight of the rack resting on them.
- In single rack installation, stabilizers should be attached to the rack.
- In multiple rack installations, the racks should be coupled together.
- Always make sure the rack is stable before extending a component from the rack.
- You should extend only one component at a time - extending two or more simultaneously may cause the rack to become unstable.

General Server Precautions

- Review the electrical and general safety precautions that came with the components you are adding to your chassis.
- Determine the placement of each component in the rack *before* you install the rails.
- Install the heaviest server components on the bottom of the rack first, and then work up.
- Use a regulating uninterruptable power supply (UPS) to protect the server from power surges, voltage spikes and to keep your system operating in case of a power failure.
- Allow the hot plug hard drives and power supply modules to cool before touching them.
- Always keep the rack's front door and all panels and components on the servers closed when not servicing to maintain proper cooling.

Rack Mounting Considerations

Ambient Operating Temperature

If installed in a closed or multi-unit rack assembly, the ambient operating temperature of the rack environment may be greater than the ambient temperature of the room. Therefore, consideration should be given to installing the equipment in an environment compatible with the manufacturer's maximum rated ambient temperature (T_{mra}).

Reduced Airflow

Equipment should be mounted into a rack so that the amount of airflow required for safe operation is not compromised.

Mechanical Loading

Equipment should be mounted into a rack so that a hazardous condition does not arise due to uneven mechanical loading.

Circuit Overloading

Consideration should be given to the connection of the equipment to the power supply circuitry and the effect that any possible overloading of circuits might have on overcurrent protection and power supply wiring. Appropriate consideration of equipment nameplate ratings should be used when addressing this concern.

Reliable Ground

A reliable ground must be maintained at all times. To ensure this, the rack itself should be grounded. Particular attention should be given to power supply connections other than the direct connections to the branch circuit (i.e. the use of power strips, etc.).

6-4 Rack Mounting Instructions

This section provides information on installing the SC815 chassis into a rack unit. There are a variety of rack units on the market, which may mean the assembly procedure will differ slightly. You should also refer to the installation instructions that came with the rack unit you are using.

NOTE: This rail will fit a rack between 26" and 33.5" deep.

Identifying the Sections of the Rack Rails

The chassis package includes two rack rail assemblies in the rack mounting kit. Each assembly consists of two sections: an inner rail that secures directly to the chassis, and an outer rail that secures directly to the rack itself.

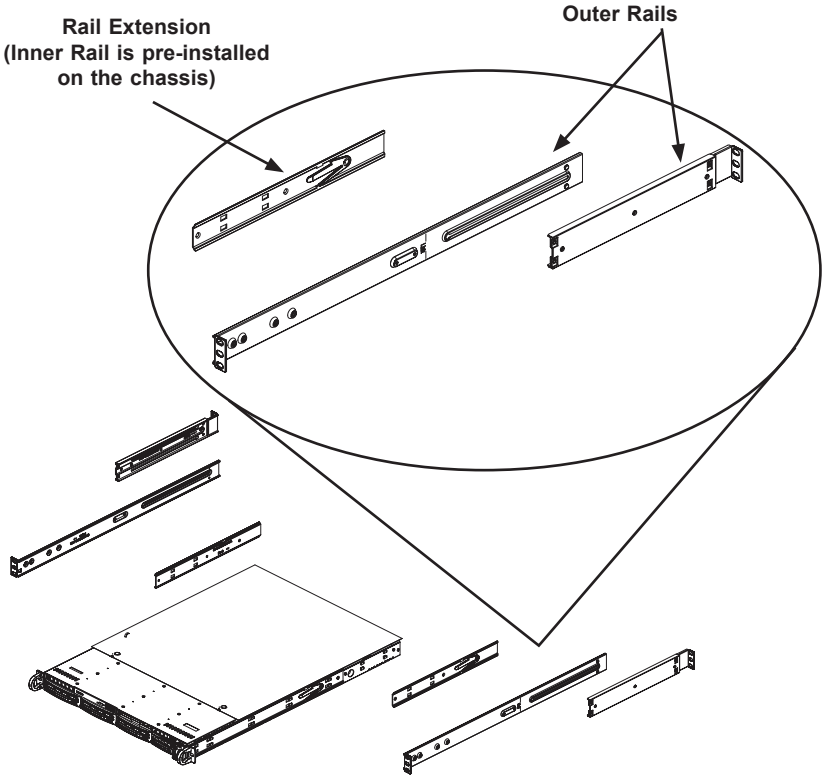
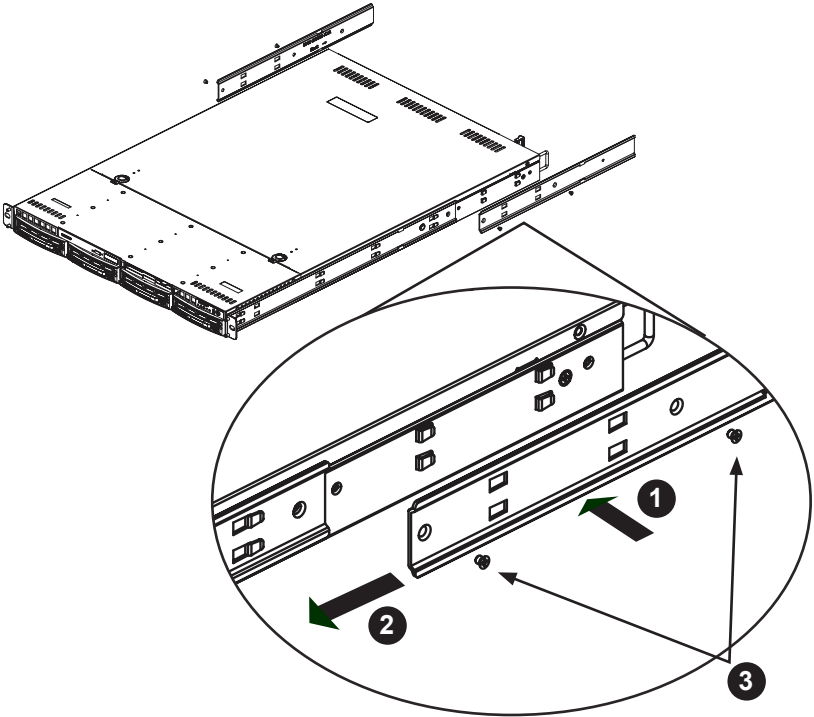

Figure 6-1: Identifying the Sections of the Rack Rails (right side rail shown)



**Figure 6-2: Identifying the Sections of the Rack Rails
(right side rail shown)**

Inner Rail Extension

The SC815 chassis includes a set of inner rails which are in two sections: inner rails and inner rail extensions. The inner rails are pre-attached and do not interfere with normal use of the chassis if you decide not to use a server rack. Attach the inner rail extension to stabilize the chassis within the rack.

Installing the Inner Rails

1. Place the inner rail extensions on the side of the chassis aligning the hooks of the chassis with the inner rail extension holes. Make sure the inner rail extension faces "outward" just like the pre-attached inner rail.
2. Slide the extension toward the front of the chassis.
3. Secure the chassis with 2 screws as illustrated.
4. Repeat steps 1-3 for the other inner rail extension.

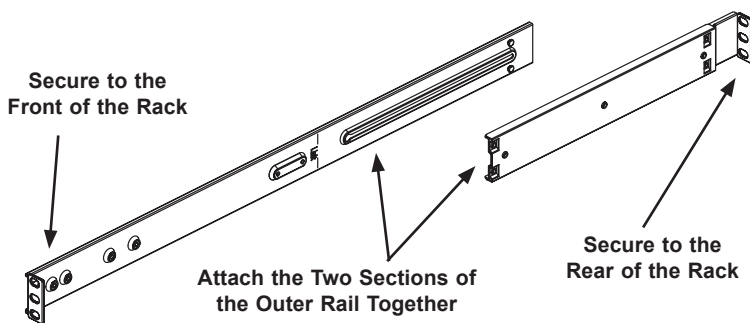

Figure 6-3: Assembling the Outer Rails

Installing the Outer Rails to the Rack

1. Attach the longer section of the outer rail to the outside of the shorter section of the outer rail. You must align the pins with the slides. Both ends of the outer rail must face the same direction in order to be secured to the rack.
2. Adjust both sections of the outer rail to the proper length so that the rail fits snugly within the rack.
3. Secure the longer section of the outer rail to the of the rack with two M5 screws and the shorter section to the rear side of the rack with two M5 screws.
4. Repeat steps 1-4 for the remaining outer rail.

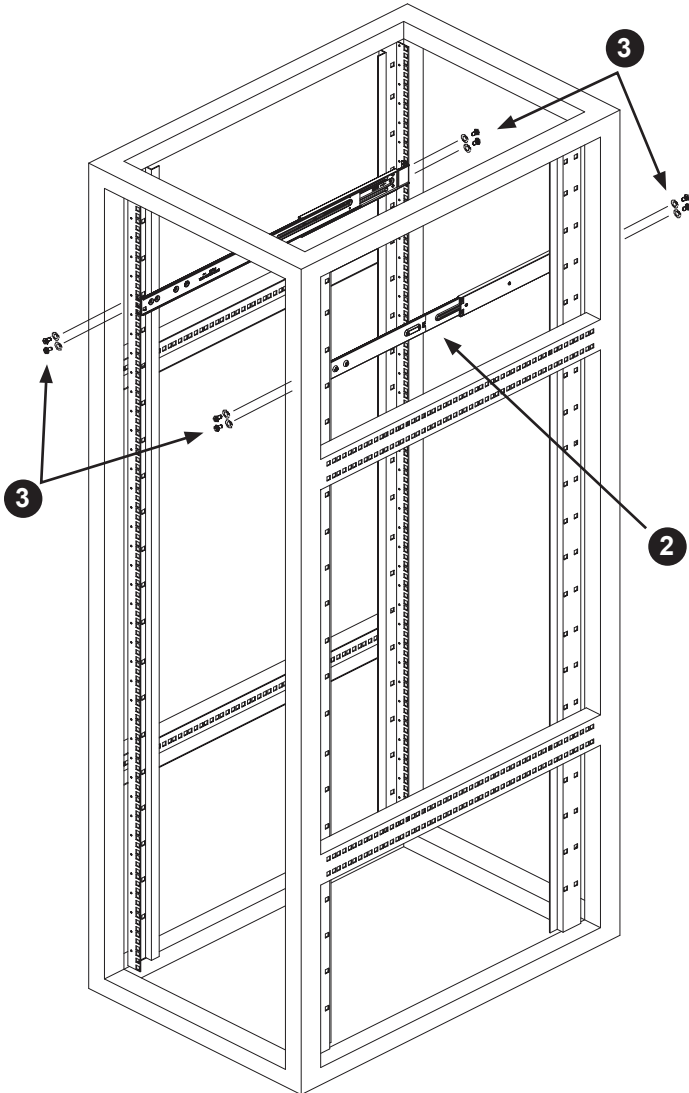

Figure 6-4: Installing the Outer Rails to the Server Rack

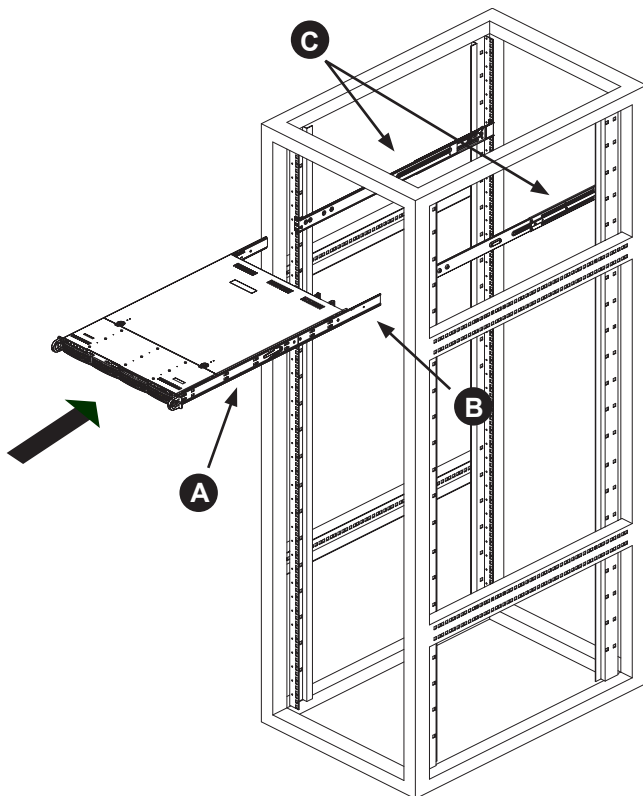

Figure 6-5: Installing the Rack Rails

Installing the Chassis into a Rack

1. Confirm that chassis includes the inner rails (A) and rail extensions (B). Also, confirm that the outer rails (C) are installed on the rack.
2. Line chassis rails (A and B) with the front of the rack rails (C).
3. Slide the chassis rails into the rack rails, keeping the pressure even on both sides (you may have to depress the locking tabs when inserting). When the server has been pushed completely into the rack, you should hear the locking tabs "click" into the locked position.
4. (Optional) Insert and tighten the thumbscrews that hold the front of the server to the rack.

Installing the Chassis into a Telco rack

To install the chassis into a Telco type rack, use two L-shaped brackets on either side of the chassis (four total). First, determine how far the server will extend out the front of the rack. Larger chassis should be positioned to balance the weight between front and back. If a bezel is included on your server, remove it. Then attach the two front brackets to each side of the chassis, then the two rear brackets positioned with just enough space to accommodate the width of the telco rack. Finish by sliding the chassis into the rack and tightening the brackets to the rack.

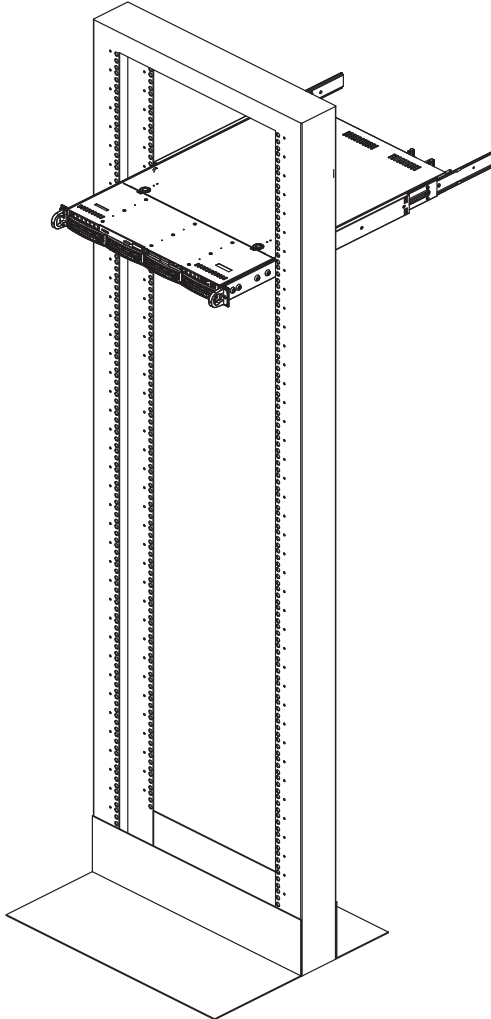

Figure 6-6: Installing the Server into a Telco Rack

Notes

Appendix A

Chassis Cables

A-1 Overview

This appendix lists supported cables for your chassis system. It only includes the most commonly used components and configurations. For more compatible cables, refer to the manufacturer of the motherboard you are using and our Web site at www.supermicro.com.

A-2 Cables Included with SC815TQ (SAS/SATA)

SC815TQ-710			
Part #	Type	Length	Description
CBL-0157L	Round ribbon cable	9"	8 pin to 8 pin ribbon cable for SGPIO.
CBL-0087	Round ribbon cable	20"	16 pin to 16 pin ribbon cable for control panel
CBL-0139L	Braid ribbon cable	50 cm	IDE 80-wire cable for DVD ROM
-	Cable	6'	Regional power cord
CBL-0180L-01	Cable set	various	SATA Set of 70/59/48/38cm round cables

SC815TQ-700			
Part #	Type	Length	Description
CBL-0157L	Round ribbon cable	9"	8 pin to 8 pin ribbon cable for SGPIO.
CBL-0087	Round ribbon cable	20"	16 pin to 16 pin ribbon cable for control panel
CBL-0139L	Braid ribbon cable	50 cm	IDE 80-wire cable for DVD ROM
-	Cable	6'	Regional power cord
CBL-0180L-01	SATA set	various	SATA set of 70/59/48/38cm Round Cables

SC815TQ-R650			
Part #	Type	Length	Description
CBL-0157L	Round ribbon cable	9"	8 pin to 8 pin ribbon cable for SGPIO.
CBL-0087	Round ribbon cable	20"	16 pin to 16 pin ribbon cable for control panel
CBL-0139L	Braid ribbon cable	50 cm	IDE 80-wire cable for DVD-ROM
-	Cable	6'	Regional power cord
CBL-0180L-01	SATA set	various	SATA Set of 70/59/48/38cm round cables

SC815TQ-560			
Part #	Type	Length	Description
CBL-0157L	Round ribbon cable	9"	8 pin to 8 pin ribbon cable for SGPIO.
CBL-0087	Round ribbon cable	20"	16 pin to 16 pin ribbon cable for control panel
CBL-0139L	Braid ribbon cable	60 cm	IDE 80-wire cable for DVD-ROM
-	Cable	6'	Regional power cord
CBL-0180L-01	SATA set	Various	SATA set of 70/59/48/38cm round cables

A-3 Cables Included with SC815S Chassis (SCSI)

SC815S-700			
Part #	Type		Description
CBL-033L-U320	Round ribbon cable	9"	ULTRA 320 cable
CBL-0087	Round ribbon cable	20"	16 pin to 16 pin ribbon cable for control panel
CBL-0139L	Braid ribbon cable	50 cm	IDE 80-wire cable for DVD-ROM
-	Cable	6'	Regional power cord

SC815S-R650			
Part #	Type	Length	Description
CBL-033L-U320	Round ribbon cable	9"	ULTRA 320 cable
CBL-0087	Round ribbon cable	20"	16 pin to 16 pin ribbon cable for control panel
CBL-0139L	Braid ribbon cable	50 cm	IDE 80-wire cable for DVD-ROM
-	Cable	6'	Regional power cords

SC815S-560			
Part #	Type	Length	Description
CBL-033L-U320	Round ribbon cable	9"	ULTRA 320 cable
CBL-0087	Round ribbon cable	20"	16 pin to 16 pin ribbon cable for control panel
CBL-0139L	Braid ribbon cable	60 cm	IDE 80-wire cable for DVD-ROM
-	Cable	6'	Regional power cord

A-4 Compatible Cables

These cables are compatible with the SC815 chassis.

Alternate SAS/SATA Cables

Some compatible motherboards have different connectors. If your motherboard has only one SAS connector that the SAS/SATA cables must share, use one of the following cables. These cables must be purchased separately.

Cable Name: SAS Cable

Quantity: 1

Part #: CBL-0175L

Alt. Name: "Big Four"

Description: This cable has one SFF-8484 (32 pin) connector on one end and 4 SAS connectors (7 pins each) at the other. This cable connects from the Host (motherboard or other controller) to the backplane SAS hard drive port.

Cable Name: SAS Cable

Quantity: 1

Part #: CBL-0116

Alt. Name: iPass or "Small Four"

Description: This cable has one ipass (SFF-8087/mini-sas) connector (36 pins) at one end and 4 SAS connectors on one end. This cable connects from the Host (motherboard or other controller) to the backplane SAS hard drive port.

Extending Power Cables

Although Super Micro chassis are designed with to be efficient and cost-effective, some compatible motherboards have power connectors located in different areas.

To use these motherboards you may have to extend the power cables to the motherboards. To do this, use the following chart as a guide.

Power Cable Extenders		
Number of Pins	Cable Part #	Length
24 pin	CBL - 0042	7.9"(20 CM)
20 pin	CBL - 0059	7.9"(20 CM)
8 pin	CBL - 0062	7.9"(20 CM)
4 pin	CBL - 0060	7.9"(20 CM)

Front Panel to the Motherboard

The SC815 chassis includes a cable to connect the chassis front panel to the motherboard. If your motherboard uses a different connector, use the following list to find a compatible cable.

Front Panel to Motherboard Cable (Ribbon Cable)		
Number of Pins (Front Panel)	Number of Pins (Motherboard)	Cable Part #
16 pin	16 pin	CBL - 0049
16 pin	20 pin	CBL - 0048
20 pin	20 pin	CBL - 0047
16 pin	Split*	CBL - 0068
20 pin	Split*	CBL - 0067

* Split cables: Use these cables if your motherboard has different pin definitions than a Supmicro motherboard.

A-5 Chassis Screws

The accessory box includes all the screws needed to setup your chassis. This section lists and describes the most common screws used. Your chassis may not require all the parts listed.

M/B



Pan head
6-32 x 5 mm
[0.197]

HARD DRIVE



Flat head
6-32 x 5 mm
[0.197]

DVD-ROM, CD-ROM, and FLOPPY DRIVE



Pan head
6-32 x 5 mm
[0.197]



Flat head
6-32 x 5 mm
[0.197]



Round head
M3 x 5 mm
[0.197]



Round head
M2.6 x 5 mm
[0.197]

RAIL



Flat head
M4 x 4 mm
[0.157]



Round head
M4 x 4 mm
[0.157]



Flat head
M5 x 12 mm[0.472]
Washer for M5



M/B STANDOFFS



M/B standoff
6-32 to 6-32



M/B (CPU)
standoff
M5 to 6-32



Thumb screw
6-32 x 5 mm
[0.197]



1/U M/B standoff
6-32 x 5 mm
[0.197]

Appendix B

SC815 Power Supply Specifications

This appendix lists power supply specifications for your chassis system.

Power Supply Specifications						
	720W	710W/ PDB	700W/PDB	650W/ PDB (Redun- dant)	560W	560W (C Mod- els)
MFR Part #	PWS-721- P-1R	PWS-711 -1R	PWS- 702A-IR	PWS-651 -1R	PWS-561 -1H20	PWS-561 -1H
Rated AC Volt- age	100-240 V, 50-60 Hz, 4-9 Amp	100 - 240V 50-60Hz 24-11 Amp	100 - 240V 50 - 60Hz 10-4 Amp	100 - 240V 50 - 60Hz 8 - 4 Amp	100 - 240V 50 - 60Hz 8.5 - 4 Amp	100 - 240V 50 - 60Hz 8.5 - 4 Amp
+5V standby	3 Amp	4 Amp	4 Amp	3 Amp	3 Amp	3 Amp
DC Output	3 Amp at +5V standby 59 Amp at +12V					
+12V		59 Amp	57 Amp	54 Amp	43.6 Amp	43.6 Amp
+5V	30 Amp	24 Amp	30 Amp	25 Amp	25 Amp	25 Amp
+3.3V	24 Amp	21 Amp	24 Amp	12 Amp	21 Amp	21 Amp
-12V	0.6 Amp	0.6 Amp	0.6 Amp	0.5 Amp	0.6 Amp	0.6 Amp

PDB: Power Distribution Board.

Notes

Appendix C

SAS-815TQ Backplane Specifications

To avoid personal injury and property damage, carefully follow all the safety steps listed below when accessing your system or handling the components.

C-1 ESD Safety Guidelines

Electrostatic Discharge (ESD) can damage electronic components. To prevent damage to your system, it is important to handle it very carefully. The following measures are generally sufficient to protect your equipment from ESD.

- Use a grounded wrist strap designed to prevent static discharge.
- Touch a grounded metal object before removing a component from the antistatic bag.
- Handle the backplane by its edges only; do not touch its components, peripheral chips, memory modules or gold contacts.
- When handling chips or modules, avoid touching their pins.
- Put the card and peripherals back into their antistatic bags when not in use.

C-2 General Safety Guidelines

- Always disconnect power cables before installing or removing any components from the computer, including the SAS-815TQ Backplane.
- Disconnect the power cable before installing or removing any cables from the SAS-815TQ Backplane.
- Make sure that the SAS-815TQ Backplane is securely and properly installed on the motherboard to prevent damage to the system due to power shortage.

C-3 An Important Note to Users

- All images and layouts shown in this user's guide are based upon the latest PCB Revision available at the time of publishing. The card you have received may or may not look exactly the same as the graphics shown in this manual.

C-4 Introduction to the SAS-815TQ Backplane

The SAS-815TQ backplane has been designed to utilize the most up-to-date technology available, providing your system with reliable, high-quality performance.

This manual reflects SAS-815TQ Revision 1.00, the most current release available at the time of publication. Always refer to the Supermicro Web site at www.supermicro.com for the latest updates, compatible parts and supported configurations.

Jumper Settings and Pin Definitions

C-4 Front Connectors and Jumpers

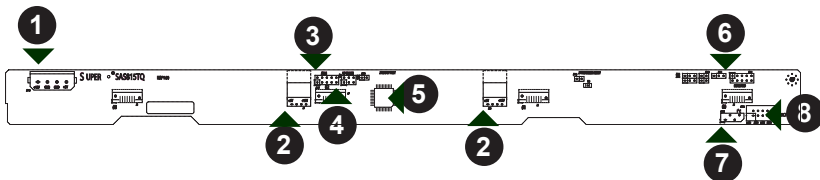

Figure C-1: Front Connectors and Jumpers

Front Connectors

- #1. Power Connectors (4-pin) JP10
- #2. CD-ROM/Floppy Drive Power J9 and J10
- #3. JTAG JP47
- #4. Upgrade Pin JP46
- #5. MG9071 Chip
- #6. Sideband JP51
- #7. I²C Connector JP44
- #8. ACT_IN JP26
- #9. SAS Port #0 J5
- #10. SAS Port #1 J6
- #11. SAS Port #2 J7
- #12. SAS Port #3 J8

SAS Ports

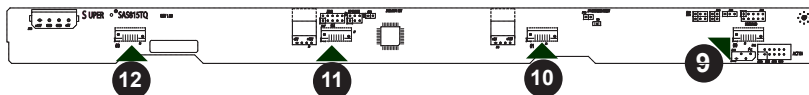

Figure C-2: SAS Ports

C-5 Front Connector and Pin Definitions

#1. Backplane Main Power Connectors

The 4-pin connectors, designated JP10 provide power to the backplane. See the table on the right for pin definitions.

Backplane Main Power 4-Pin Connector	
Pin#	Definition
1	+12V
2 and 3	Ground
4	+5V

#2. CD-ROM/Floppy 4-Pin Connectors

The 4-pin connectors, designated J9 and J10, provide power to the CD-ROM and floppy drives. See the table on the right for pin definitions.

CD-ROM/ FDD Power 4-Pin Connector	
Pin#	Definition
1	+5V
2 and 3	Ground
4	+12V

#3., #4. JTAG Connector and Upgrade Connector

The JTAG connector, designated JP47, and the Upgrade connector, designated JP46, are diagnostic purposes. These connectors should be used by a certified and experienced technician.

#4. MG9071 Chip

The MG9071 is an enclosure management chip that supports the SES-2 controller and SES-2 protocols.

#6. Sideband Headers

The sideband headers are designated JP51. For SES-2 to work properly, you must connect an 8-pin sideband cable. See the table to the right for pin definitions.

Sideband Headers			
Pin #	Definition	Pin #	Definition
2	Backplane Addressing (SB5)	1	Controller ID (SB6)
4	Reset (SB4)	3	GND (SB2)
6	GND (SB3)	5	SDA (SB1)
8	Backplane ID (SB7)	7	SCL (SB0)
10	No Connection	9	No Connection

#7. I²C Connectors

The I²C Connectors, designated JP44, are used to monitor HDD activity and status. See the table on the right for pin definitions.

I ² C Connector Pin Definitions	
Pin#	Definition
1	Data
2	Ground
3	Clock
4	No Connection

#8. Activity LED Header

The activity LED header, designated JP26, is used to indicate the activity status of each SAS drive. For the Activity LED Header to work properly, connect using a 10-pin LED cable.

SAS Activity LED Header Pin Definitions			
Pin #	Definition	Pin #	Definition
1	ACT IN#0	6	ACT IN#4
2	ACT IN#1	7	ACT IN#5
3	ACT IN#2	8	ACT IN#6
4	ACT IN#3	9	ACT IN#7
5	Ground	10	Empty

#9., #12. SAS Ports

The SAS ports are used to connect the SAS drive cables. The four ports are designated #0 - #4. Each port is also compatible with SATA drives.

C-6 Front Jumper Locations and Pin Definitions

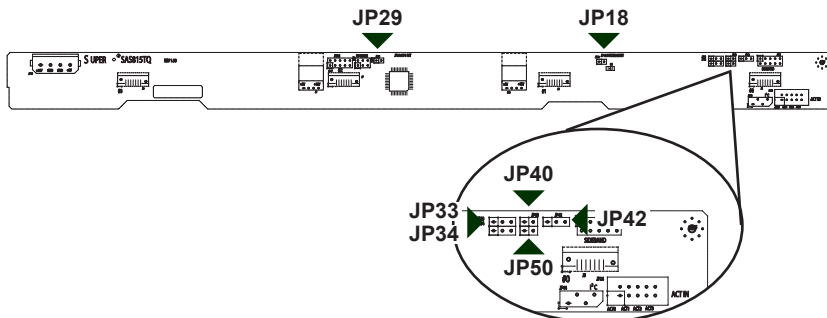
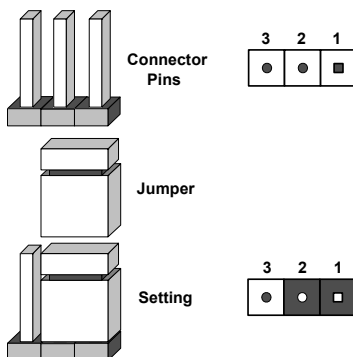

Figure C-3: Front Connectors and Jumpers

Explanation of Jumpers

To modify the operation of the backplane, jumpers can be used to choose between optional settings. Jumpers create shorts between two pins to change the function of the connector. Pin 1 is identified with a square solder pad on the printed circuit board. Note: On two pin jumpers, "Closed" means the jumper is on and "Open" means the jumper is off the pins.



Jumper Settings		
Jumper	Jumper Settings	Note
JP18	Open: Enabled Closed: Disabled	Buzzer reset*
JP29	Open: Default Closed: Reset	MG9071 Chip reset

*The buzzer sound indicates that a condition requiring immediate attention has occurred.

The buzzer alarm is triggered by the following conditions:

1. Hard drive failure
2. Fan failure
3. System temperature over 45° Celsius.

I²C and SGPIO Modes and Jumper Settings

This backplane can utilize I²C or SGPIO. I²C is the default mode and can be used without making changes to your jumpers. The following information details which jumpers must be configured to use SGPIO mode or restore your backplane to I²C mode.

I ² C Setting (Default)		
Jumper	Jumper Setting	Note
JP33	2-3	Controller ID
JP34	1-2:ID#0	Backplane ID
JP40	Open	I ² C Reset SD OUT
JP42	2-3	Backplane ID SDIN
JP50	Closed	I ² C Reset

SGPIO Setting		
Jumper	Jumper Setting	Note
JP33	1-2	Controller ID
JP34	1-2:ID#0	Backplane ID
JP40	Closed	I ² C Reset SD OUT
JP42	1-2	Backplane ID SDIN
JP50	Open	I ² C Reset

Front LED Indicators

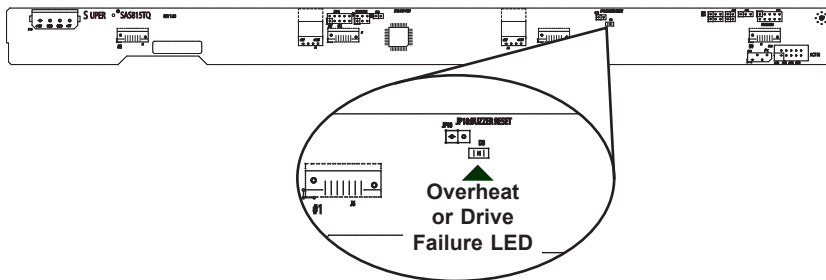

Figure C-4: Front LED Indicators

Front Pane LEDs		
LED	State	Specification
D3	On	Overheat or drive failure

C-7 Rear Connectors and LED Indicators

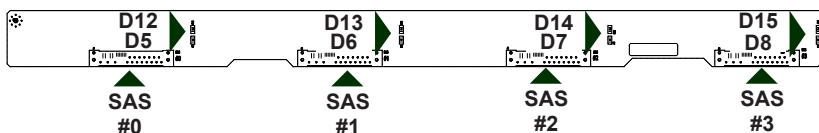

Figure C-5: Rear Connectors and LED Indicators

Rear SAS/SATA Connectors		
Rear Connector	Connector Number	SAS Drive Number
SAS #0	J1	SAS/SATA HDD #0
SAS #1	J2	SAS/SATA HDD #1
SAS #2	J3	SAS/SATA HDD #2
SAS #3	J4	SAS/SATA HDD #3

Rear LED Indicators		
Rear Connector	Hard Drive Activity	Failure LED
SAS #0	D12	D5
SAS #1	D13	D6
SAS #2	D14	D7
SAS #3	D15	D8

Appendix D

SCA-813S Backplane Specifications

To avoid personal injury and property damage, carefully follow all the safety steps listed below when accessing your system or handling the components.

D-1 ESD Safety Guidelines

Electrostatic Discharge (ESD) can damage electronic components. To prevent damage to your system, it is important to handle it very carefully. The following measures are generally sufficient to protect your equipment from ESD.

- Use a grounded wrist strap designed to prevent static discharge.
- Touch a grounded metal object before removing a component from the antistatic bag.
- Handle the backplane by its edges only; do not touch its components, peripheral chips, memory modules or gold contacts.
- When handling chips or modules, avoid touching their pins.
- Put the card and peripherals back into their antistatic bags when not in use.

D-2 General Safety Guidelines

- Always disconnect power cables before installing or removing any components from the computer, including the SCA-813S backplane.
- Disconnect the power cable before installing or removing any cables from the SCA-813S backplane.
- Make sure that the SCA-813S backplane is securely and properly installed on the motherboard to prevent damage to the system due to power shortage.

D-3 An Important Note to Users

- All images and layouts shown in this user's guide are based upon the latest PCB Revision available at the time of publishing. The card you have received may or may not look exactly the same as the graphics shown in this manual.

D-4 Introduction to the SCA-813S Backplane

The SCA-813S backplane has been designed to utilize the most up-to-date technology available, providing your system with reliable, high-quality performance.

This manual reflects SCA-813S Revision 1.00, the most current release available at the time of publication. Always refer to the Supermicro Web site at www.supermicro.com for the latest updates, compatible parts and supported configurations.

Jumper Settings and Pin Definitions

D-5 Front Connectors and Jumpers

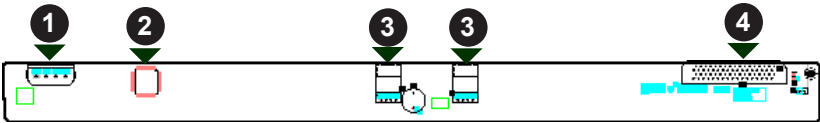

Figure D-1: Front Connectors and Jumpers

Front Connectors

- #1. Backplane Main (4-Pin) PWR: JP10
- #2. GEM 318 Chip
- #3. CD-ROM/Floppy Drive (4-Pin) PWR Connector: J1 and J2
- #4. SCSI Channel: LVD1

D-6 Front Connector and Pin Definitions

#1. Backplane Main Power Connectors

The 4-pin connector, designated JP10, provide power to the backplane. See the table on the right for pin definitions.

Backplane Main Power 4-Pin Connector	
Pin#	Definition
1	+12V
2 and 3	Ground
4	+5V

#2. GEM Chip (SAF-TE: SCSI Accessed Fault-Tolerant Enclosures)

The GEM chip allows the system to monitor the status of the disk drives and provides disk drive information to the user through the LED indicators and buzzers.

This function is only available when a RAID controller with a Raid set is present and enabled.

SAF-TE LED Indicators		
LED #	Location	Description
D4	Front	Overheat or Drive Failure (red light, flashing, buzzer on)
D5	Rear	SCA#0 Fail LED (red light, flashing, buzzer on)
D6	Rear	SCA#1 Fail LED (red light, flashing, buzzer on)
D16	Rear	SCA#2 Fail LED (red light, flashing, buzzer on)
D18	Rear	SCA#3 Fail LED (red light, flashing, buzzer on)

#3. CD-ROM/Floppy 4-Pin Connectors

The 4-pin connectors, designated J1 and J2, provide power to the CD-ROM and floppy drives. See the table on the right for pin definitions.

CD-ROM/ FDD Power 4-Pin Connector	
Pin#	Definition
1	+5V
2 and 3	Ground
4	+12V

#4. Ultra 320 SCSI Connector (LVD1)

The Ultra 320 SCSI connector connects the backplane to the server motherboard.

Ultra320 SCSI Drive Connector Pin Definitions (J28)			
Pin#	Definition	Pin #	Definition
1	+DB (12)	35	-DB (12)
2	+DB (13)	36	-DB (13)
3	+DB (14)	37	-DB (14)
4	+DB (15)	38	-DB (15)
5	+DB (P1)	39	-DB (P1)
6	+DB (0)	40	-DB (0)
7	+DB (1)	41	-DB (1)
8	+DB (2)	42	-DB (2)
9	+DB (3)	43	-DB (3)
10	+DB (4)	44	-DB (4)
11	+DB (5)	45	-DB (5)
12	+DB (6)	46	-DB (6)
13	+DB (7)	47	-DB (7)
14	+DB (P)	48	-DB (P)
15	Ground	49	Ground
16	DIFFSENS	50	Ground
17	TERMPWR	51	TERMPWR
18	TERMPWR	52	TERMPWR
19	Reserved	53	Reserved
20	Ground	54	Ground
21	+ATN	55	-ATN
22	Ground	56	Ground
23	+BSY	57	-BSY
24	+ACK	58	-ACK
25	+RST	59	-RST
26	+MSG	60	-MSG
27	+SEL	61	-SEL
28	+C/D	62	-C/D
29	+REQ	63	-REQ
30	+I/O	64	-I/O
31	+DB (8)	65	-DB (8)
32	+DB (9)	66	-DB (9)
33	+DB (10)	67	-DB (10)
34	+DB (11)	68	-DB (11)

D-7 Front Jumper Locations and Pin Definitions



Figure D-2: Front Jumper

Explanation of Jumpers

To modify the operation of the backplane, jumpers can be used to choose between optional settings. Jumpers create shorts between two pins to change the function of the connector. Pin 1 is identified with a square

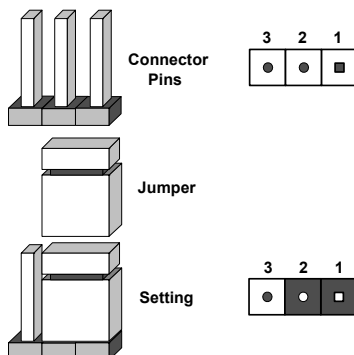

Jumper Settings		
Jumper	Jumper Settings	Note
JP17	Closed: Enabled Open: Disabled	Buzzer enable*

*The buzzer sound indicates that a condition requiring immediate attention has occurred.

The buzzer alarm is triggered by the following conditions:

1. Hard drive failure
2. Fan failure
3. System temperature over 45° Celsius.

Front LED Indicators

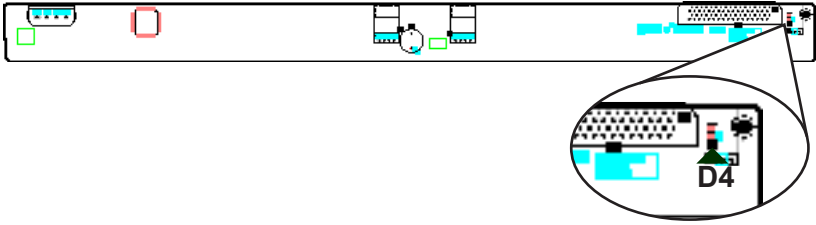

Backplane LED		
LED	State	Specification
D4	On	Overheat/Drive Failure LED Indicator (Red light: flashing, Buzzer: On)

D-8 Rear Connectors and LED Indicators

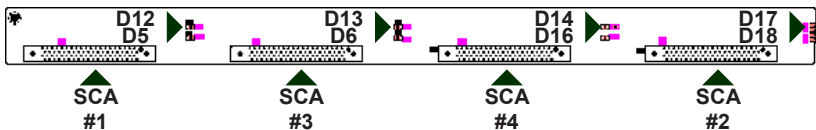

Figure D-4: Rear Connectors and LED Indicators

Rear SCA Connectors		
Rear Connector	Connector Number	SCA Drive Number
SCA #1	#0	SCA HDD #0
SCA #3	#1	SCA HDD #1
SCA #4	#2	SCA HDD #2
SCA #2	#3	SCA HDD #3

Rear LED Indicators			
Rear LED	Connector Number	Hard Drive Activity	Failure LED
SCA #1	#0	D12	D5
SCA #3	#1	D13	D6
SCA #4	#2	D14	D16
SCA #2	#3	D17	D18

D-8 SCSI (Super) GEM Installation Instructions for the Windows Operating System

The following instructions describe how to install the SCSI GEM driver for the Windows OS systems. This driver is not necessary for other operating systems. If you have two SCA backplanes, you will need to install the driver twice.

The driver is located on the Supermicro motherboard driver CD is available for download from our FTP site: ftp://ftp.supermicro.com/driver/SCSI_Backplanes/Qlogic/

Use ONE of the following Windows installation procedures to install the drivers to your system.

Windows Driver Installation Procedure A

1. Right click **My Computer** and select **Properties**.
2. Select the **Hardware** tab and click **Device Manager**.
3. Open **Other Devices** or the other location of **GEM318**.
4. Right click on this device and select **Properties**.
5. Select the **Driver** tab and select **Update Driver**.
6. Click **Next** twice, uncheck both the **Floppy disk drive** and **CD-ROM drive** options.
7. Select **Specify a location**, and click **Next**.
8. Click on **Browse** and select the **D drive**, or other location for the Supermicro Setup CD.
9. Select the **Qlogic** folder and click **Open**.
10. System will automatically detect the GEM318 chip and install the drive from this point on.

Windows Driver Installation Procedure B

Installation Procedure B

1. Right click the **My Computer** icon on your desktop and select **Properties**.

2. Select the **Hardware** tab and select **Device Manager** to bring up the list of system devices.
3. You may see one or two yellow question marks (?) that read QLogic GEM354 or GEM318 SCSI Processor Device. Right click on these, and select **uninstall**. If both devices have question marks, uninstall both.
4. Select the **Action** tab and select **Scan for Hardware Changes**. The Hardware Wizard program should start up. Click **Next**.
5. At the first prompt, select **Display a list of known device drivers for the device so that I can choose a specific driver** and click **Next**.
6. Select **Other Devices** and click **Next**.
7. Select **Have Disk**, and specify the **floppy drive location** in the options box. Then click **Next**.
8. Select **Enclosure Services Device** and click **Next**.
9. Ignore the warning prompt by clicking **Yes**.

Notes

Disclaimer (cont.)

The products sold by Supermicro are not intended for and will not be used in life support systems, medical equipment, nuclear facilities or systems, aircraft, aircraft devices, aircraft/emergency communication devices or other critical systems whose failure to perform be reasonably expected to result in significant injury or loss of life or catastrophic property damage. Accordingly, Supermicro disclaims any and all liability, and should buyer use or sell such products for use in such ultra-hazardous applications, it does so entirely at its own risk. Furthermore, buyer agrees to fully indemnify, defend and hold Supermicro harmless for and against any and all claims, demands, actions, litigation, and proceedings of any kind arising out of or related to such ultra-hazardous use or sale.