

Contents

I. General	2
II. Main Specifications	2
III. Quoted Standards.....	2
IV. Environmental Conditions	3
V. Electrical Characteristics.....	4
VI. Other Requirements.....	6
VII. Safety & EMC.....	6
VIII. Alert, Monitor & Interface	7
IX. Environmental Testing Requirements	8
X. Mechanical Characteristics.....	8
XI. Package, Transportation and Storage	14
XII. Reliability Requirements.....	15
XIII. Attentions.....	15
XIV. Label.....	15

I. General



This model of power supply is systemic one which features wide input voltage range, output voltage 54.5V, max output current 5A for single rectified module, and floating charge for battery. System has two rectified modules which are integrated, and then output. Output voltage refers to voltage after integration. There is a monitoring module that communicates with supervisory control computer by RS232 to monitor power supply and battery.

II. Main Specifications

Output Power	Input Voltage Range	Output Rated Voltage	Min Output Current	Max Output Current	Output Ripple & Noise (Full load, frequency band is limited to 20MHz)
				Forced Cooling	
540W (typical value, air cooling)	90—264Vac	+54.0V	0A	10A	≤200mVp-p

III. Quoted Standards

- GB/T 2423.1-2001 Environmental testing for electric and electronic products—Part 2: Test methods—Tests A: Cold
- GB/T 2423.2-2001 Environmental testing for electric and electronic products—Part 2: Test methods—Tests B: Dry heat
- GB/T 2423.3-1993 Basic environmental testing procedures for electric and electronic products Test Ca: Damp heat, steady state
- GB/T 2423.4.1993 Basic environmental testing procedures for electric and electronic products Test Db: Damp heat, cyclic
- GB/T 2423.5-1995 Environmental testing for electric and electronic products—Part 2: Test methods —Tests Ea and guidance: Shock
- GB/T 2423.6-1995 Environmental testing for electric and electronic products—Part 2: Test methods —Tests Ea and guidance: Bump
- GB/T 2423.8-1995 Environmental testing for electric and electronic products—Part 2: Test methods —Tests Ed and guidance: Free drop
- GB/T 2423.10-1995 Environmental testing for electric and electronic products—Part 2: Test methods —Tests Fc and guidance: Vibration (Sinusoidal)
- GB/T 2423.11-1997 Environmental testing for electric and electronic products—Part 2: Test methods —Tests Fd and guidance: Random vibration wide band—General requirements
- GB/T 2423.22-2002 Environmental testing for electric and electronic products—Part 2: Test methods —Tests N: Change of temperature

GB/T 14508-93 Mechanical environmental conditions existing in the cargo transportation by classed highway

EN55022 : 1998 Information technology equipment—Radio disturbance characteristics—Limits and methods of measurement

EN55024: 1998 Information technology equipment—Immunity characteristics—Limits and methods of measurement

CEI IEC 61000-4-2 2001 Electromagnetic compatibility—Testing and measurement techniques—Electrostatic discharge immunity test

CEI IEC 61000-4-3 2002 Electromagnetic compatibility—Testing and measurement techniques—Radiated, radio frequency, electromagnetic field immunity test

CEI IEC 61000-4-4 1998 Electromagnetic compatibility—Testing and measurement techniques—Electrical fast transient/burst immunity test

CEI IEC 61000-4-5 1999 Electromagnetic compatibility—Testing and measurement techniques—Surge immunity test

CEI IEC 61000-4-6 2001 Electromagnetic compatibility—Testing and measurement techniques—Immunity to conducted disturbances, induced by radio-frequency fields

CEI IEC 61000-4-8 1993 Electromagnetic compatibility—Testing and measurement techniques—Power frequency magnetic field immunity test

CEI IEC 61000-4-11 1994 Electromagnetic compatibility—Testing and measurement techniques—Voltage dips short interruptions and voltage variations immunity test

CEI IEC 61000-4-29 2000 Electromagnetic compatibility—Testing and measurement techniques—Voltage dips short interruptions and voltage variations on d.c. input port immunity test

IEC 61000-3-2 2001 Electromagnetic compatibility—Limits for harmonic current emissions (equipment input current $\leq 16A$ per phase)

IEC 61000-3-3 1995 Electromagnetic compatibility—Limitation of voltage fluctuations and flicker in low voltage supply systems for equipment with rated current $\leq 16A$

GB4943-2001 Safety of information technology equipment

YD/T 282-2000 General reliability test methods for communication equipment

GB/T 13722-92 Performance requirements and testing methods for power supplies used in the mobile communication

YD/T 732-95 Methods of measurement for DC-DC convertor used in communications

YD/T 731-2002 High Frequency Switch-mode Rectifier for Telecommunication

IV. Environmental Conditions

No.	Items	Technical Specifications	Unit	Remarks
1	Operating Temperature Limiting	-25—+65	°C	Use for estimation instead of criterion
2	Rated Operation Temperature	-5—+55	°C	Rated input, full load
3	Storage Temperature	-50—+70 (Typical value 25)	°C	
4	Relative Humidity	5%—95%		No condensing
5	Cooling	Air cooling with self-fan		
6	Altitude	$\leq 3,000$	m	Operating normally, and reduce 1°C per 100m rising, when altitude is above 3000m.

V. Electrical Characteristics

1 Input Characteristics					
No.	Items		Technical Specifications	Unit	Remarks
1.1	Input rated voltage		100—240	Vac	
1.2	Input voltage range		90—264	Vac	Rated input, full load
1.3	Input voltage range limiting		90—280	Vac	
1.4	Input voltage frequency		47—63	Hz	
1.5	Input Current		<8.4	A	Lowest input voltage, rated load
1.6	Input Shock Current		<50	A	Cold start-up, max input voltage
2 Output Characteristics					
No.	Items		Technical Requirements	Unit	Remarks
2.1	Min output current		0	A	
2.2	Max output current		10	A	Forced air cooling
2.3	Output voltage range		+54±0.5	Vdc	Power supply voltage refers to the voltage after two rectified modules are integrated (voltage drop inside distribution unit is 0.3V)
2.4	Output ripple & noise		≤200	mVp-p	Rated load, frequency band is limited to 20MHz
2.5	PFC		>0.95		Input voltage 264 —280Vac, it is OK for PFC to be not satisfied with 0.95
2.6	Output power		270 (typical value)	W	Air cooling, for single module
2.7	Efficiency		>80%		Rated input voltage (220Vac) rated load
2.8	Turn-on output delay		≤5	S	Vin=220Vac
2.9	Output rising time		≤100	mS	Output voltage rises from 10% to 90%, rated load.
2.10	Output holding time		>10	mS	
2.11	Turn on/off overshoot		≤5	%Vo	
2.12	Transient Response	Overshoot	≤5	%Vo	
		Recovery time	≤200	μS	25%—50%—25% or 50%—75%—50% load change
2.13	Temperature coefficient		±0.02	%/°C	
2.14	LS terminal voltage (for single module)		2.0V±0.2	V	Output 5A
			1.0V±0.2		Output 2.5A

2.15	Current sharing imbalance	≤ 15	%	Current sharing when output voltage difference is 1.5V between two modules.
2.16	Charging characteristics	47 ± 0.6	V	CLICON-3.0V
		40 ± 0.6	V	CLICON-3.5V
3	Module Protection Characteristics			
No.	Items	Technical Requirements	Unit	Remarks
3.1	Output overvoltage protection	60—62 (typical value 61)	V	Locked
3.2	Output current limiting (for single module)	5.5—6.5	A	
3.3	Output short circuit protection	No destruction with short circuit for long time, and auto-recover upon the removal of failure.		
3.4	Overtemperature protection	Protection function for overtemperature, and auto-recover upon removal of overtemperature.		
4	Battery Management Characteristics			
No.	Items	Technical Requirements	Unit	Remarks
4.1	Number for backup battery group	1	group	
4.2	Floating charge voltage	53.5—54.5	V	
4.3	Floating charge current limiting	1.7—2	A	Max value is not over 2A
4.4	Undervoltage alert point	46 ± 1	V	
4.5	Turn off protection point	43.5 ± 0.2	V	
4.6	Ground fault current	None		Assure it less than 0.35mA
4.7	Recovery point	Turn on again until rectified module AC input when battery turns off.		
4.8	Temperature compensation coefficient	None		No function for temperature compensation
4.9	Set battery group capacity arrangement	7 or 12	AH	Default
		17—30	AH	Optional arrangement. Supervisory control computer sets battery capacity arrangement when charging current limiting is 3A and current precision point is $\pm 5\%$
4.10	Reverse input polarity protection for battery	Presence		
4.11	Battery current limiting	Current limiting for battery discharge		

VI. Other Requirements

No.	Items	Requirements	Remarks
1	Noise	Less than 50dB	
2	Hot swappable	Support hot swappable. No influence to input/ output when hot swap.	
3	Failure separation	Reliable separation when one module fails, and no influence to the other module.	
4	Remote compensation	None	
5	Voltage drop for distribution unit	Less than 0.3V	
6	Lightning protection	Differential mode 3KA/common mode 5KA for ± 5 times.	Waveform 8/20us, no destruction
		Series connection fuse with protective loop.	

Remarks: Requirements for noise testing:

1. Put testing sample with full arrangement on the state of non- package and non-electricity to the center of EMC darkroom.
2. Wipe off all the background noise in the darkroom.
3. Test the sample noise when electricity is put on and fan rotates with max speed.
4. Make psophometer 0.6m away from shelf, and 1.5m from ground, and then test four facets of sample.

VII. Safety & EMC

No.	Items	Criteria	Remarks	
1	Dielectric Strength	Input—Output	3000Vac/15mA/1min	No flashover and breakdown. It is right to use DC which is peak of AC voltage.
		Input—Ground	1800Vac/10mA/1min	
		Output—Ground	500Vac/10mA/1min	
2	Isolation Resistance	Input—Output	$\geq 10M \Omega @ 500Vdc$	Under normal atmospheric pressure, relative humidity is 90%, testing voltage is 500Vdc.
		Input—Ground	$\geq 10M \Omega @ 500Vdc$	
		Output—Ground	$\geq 10M \Omega @ 500Vdc$	
3	Ground Fault Current	<3.5mA	Input to ground	
4	Resistance to ground	<0.1 Ω	Connect 40A/2min to the metal case and NW	
5	Safety	Design meets UL60950 and EN60950, and final product meets TUV, CE and UL	UL60950/EN60950/CE MARK	
6	EMC	CE	CLASS B	EN55022
		RE	CLASS B	EN55022
		ESD	LEVEL 3	EN61000-4-2
		RS	10V/m	EN61000-4-3
		CS	10V	EN61000-4-6
		EFT	LEVEL 3	EN61000-4-4
		SUGER	LEVEL 4	EN61000-4-5

7	Voltage DIP		EN61000-4-11
8	Harmonic wave		IEC61000-3-2
9	Voltage fluctuation & flicker		IEC61000-3-3

VIII. Alert, Monitor & Interface

1. Alert

Alert or mute for commercial power or not, for fuse burned or not on two loads, for battery fuse burned or not. Alert for output DC over/undervoltage, for over/undervoltage and current limiting of rectified module.

Set output DC over/undervoltage alert point:

Undervoltage alert point: $46 \pm 1V$ recovery point : $48 \pm 1V$;

overvoltage alert point: $58 \pm 1V$

2. Monitor

Monitor module sends alert/state information to supervisory control computer.

State signal : Alert or mute for commercial power or not, for fuse burned or not on two loads, for battery fuse burned or not. Alert for output DC over/undervoltage, for over/undervoltage and current limiting of two rectified modules. And the number & address of power modules

Data for Monitoring signal board

1) .Provide latest complete monitoring data for inquiry of supervisory control computer at any time. If no inquiry, send alert signal to supervisory control computer.

2) .Alert for these states of output over/undervoltage or output current limiting, and send it to monitoring board from rear board by relay contact which should be high resistance when operating and low resistance when alert.

3) .Send out alarm in terms of relay contact through pin6, 7, 8, 9.

Rectified module alarms: Pin8—pin9 connected; it operates normally: Pin8--pin9 disconnected

AC blackout alarms: Pin8—pin7 connected; AC inputs normally: Pin8--pin7 disconnected

Battery undervoltage alarms: Pin8—pin6 connected; battery voltage recovers normally: Pin8--pin6 disconnected.

The relay's maximum contact voltage is 60Vdc.

The relay's maximum contact current is 300mA.

4) . No influence without monitoring single board. Under battery default, no influence for backup battery charge/discharge management.

5) . Monitoring single board can save the latest 10 alerting information for inquiry of supervisory control computer. Optimize saving information, for example: save information for commercial power blackout alert instead of module output undervoltage alert because of power blackout.

6) . Supervisory control computer can get ride of inner information of monitoring module.

Battery management: No influence for backup battery management without monitoring module when rear battery is 7AH or 12AH. When rear battery is between 17–30A, supervisory sends order to set battery arrangement, at then charging battery current limiting is 3A.

3. Interface

There is a three-core AC input socket for power supply input which are integrated in the rear panel. There are two DC output interfaces, one backup battery interface, monitoring interface RS232.

IX. Environmental Testing Requirements

Items	Requirements	Results
High temperature operation	65°C, 24Hrs .Tested firstly under high temperature of 65°C & normal atmosphere pressure for 16hrs; then for 4hrs under high temperature low atmosphere pressure and 4hrs under high temperature high atmosphere pressure and rapidly switch on/off less than 5 times.	Power module works normally, power on/down normally.
Low temperature operation	-25°C, 24Hrs. Tested firstly under low temperature of -25°C & normal atmosphere pressure for 16hrs; then for 4hrs under low temperature & low atmosphere pressure and 4hrs under low temperature & high atmosphere pressure and rapidly switch on/off less than 5 times.	Power module works normally, power on/down normally.
High Temperature Storage	Stored under 70°C for 24hrs, and recover for 2hrs under room temperature	Power module works normally
Los temperature Storage	Stored under -40 °C for 24hrs, and recover for 2hrs under room temperature	Power module works normally
High/low temperature variation	-25–65 °C, 5 °C/min, under limit temperature for each 2hrs and vary temperature for 2 circles	Power module works normally
Vibration	Random vibration: sample can endure 5-500Hz random vibration at 3 axis for 20 minutes each, acceleration spectral density of 5–10Hz is 13 m ² /s ³ , 10–200Hz is 3m ² /s ³ , 200–500Hz is 1m ² /s ³ .	Power module works normally after test.
	Operation vibration: 3 axis for 90 minutes each under frequency range of 5-100-5Hz with acceleration of 0.1g and scan frequency of 0.1oct/min.	Power module works normally during testing.
Shock	Shock wave shape: Half sine wave at 3 axis for ±3 times each with peak value acceleration of 300m/S ² & pulse width of 9mS.	Corporation standard of Q/DKBA1124-2002
Drop	On 6 sides for one time each at the height of 100cm.	No effect on electric performance of module.
Dust-proof	Dust-proof function is needed.	

X. Mechanical Characteristics

1. Outline dimensions

$$L \times W \times H = 482.6 \times 262(\text{With handle}) \times 43.4 \quad (\text{Unit: mm})$$

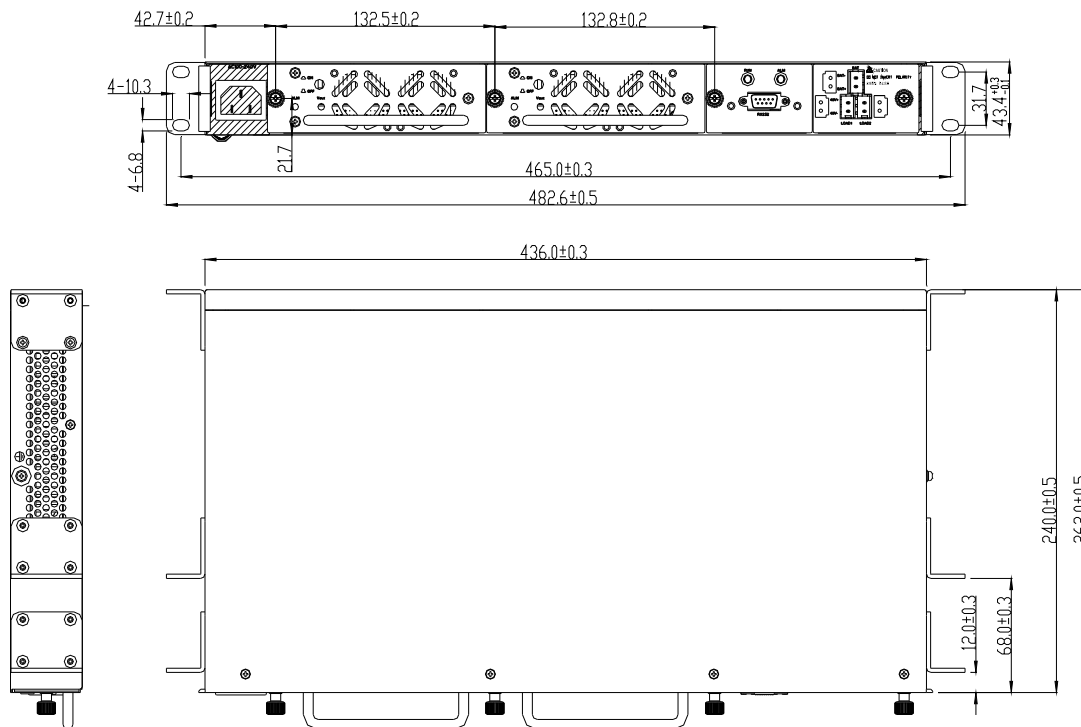

Note:

- 1) Dimension of depth refer to requirements of ETSI 300 deep-rack, the whole dimension after wire assembled is no more than 280mm.
- 2) Dimension of height is 43mm.
- 3) Fixation bar is compatible with TSI and 19 inch standard.
- 4) Surface process: spray powder with Huawei white sandy texture, the fixable bar is connected with electric system of whole outer rack; both standard of 19inch & ESTI employ the same fixable bar with silk-printing font of Arial Bold & color of Black 6U.

2. Requirements of front panel

- 1) Single rectifier module: there is one button-switch, two indication light and hole for fan area on front panel of single rectifier module.
- 2) Indication light definition: green on means power output ok and red means output failure.
- 3) Monitoring module: there is one RS232 interface & two indication lights on the monitoring module. Green light flash means runs ok and red light on means failure.
- 4) Output module: output section is designed as one power module which is drawable for the purpose of changing fuse of two circuit of outputs and one circuit of battery avoiding effect on normal power while module is inserted or drew. There should be one piece of LBD which indicates GOOD while off and fusion while red near each fuse There are two output sockets & one battery charging output interface on the output front panel. The socket is two-pin standard one with anti-reverse function.

3. Input port definition

a. AC socket definition

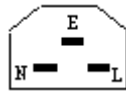

AC socket	Terminal specs
E	PGND
N	AC input N-wire
L	AC input L-wire

4. Output port Definition

a. RS232 Interface definition:

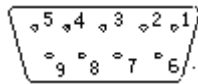

RS232	Terminal Specs
1	NC
2	RXD
3	TXD
4	NC
5	GND
6	Relay contact output for battery undervoltage alarm
7	Relay contact output for AC blackout alarm
8	Common output port for alarm relay contact
9	Relay contact output for rectified module alarm

b. DC output port definition :

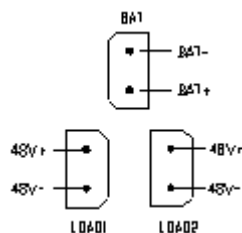

BAT	Terminal Specs	LOAD1	Terminal Specs	LOAD2	Terminal Specs
BAT-	Battery negative polarity	48V+	Positive polarity of load1	48V+	Positive polarity of load2
BAT+	Battery positive polarity	48V-	Negative polarity of load1	48V-	Negative polarity of load2

5. Back panel interface definition:

(1) Interface of power module

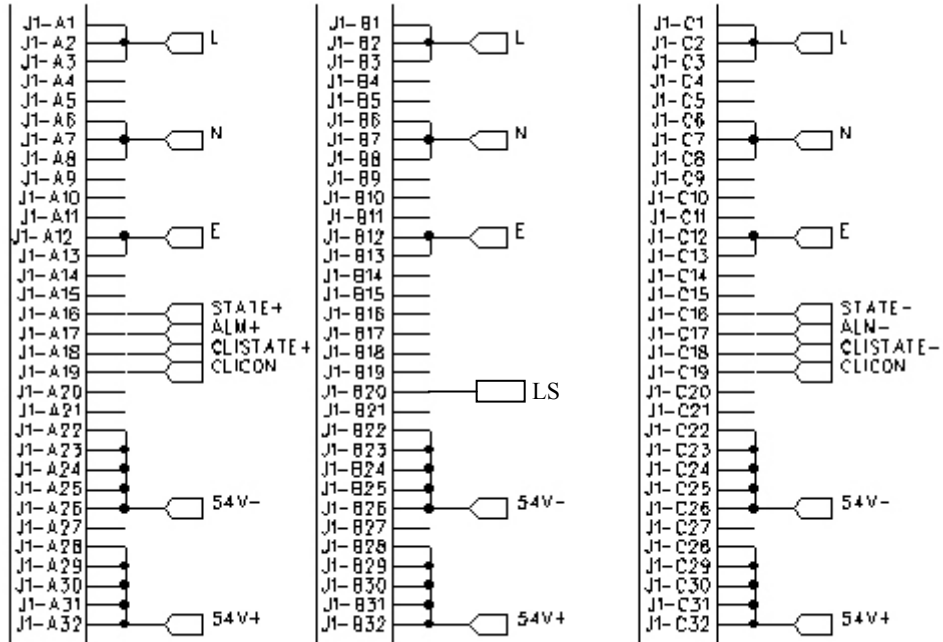

Definition is as below:

Name of signal	Definition	Remark
L	Live wire of AC input	
N	None wire of AC input	
E	PGND	
STATE+	Positive port of on present signal which is short-circuit with STATE- inside module	Internal short-circuit inside power module via a 100 Ω resistor, which is low resistance when module is on present when power
STATE-	Negative port of on present signal which is short-circuit with STATE+ inside module	
ALM+	Positive port of alert of no output and undervoltage, alerting coupler output to collector	High resistance while module alert and low while normal.
ALM-	Negative port of alert of no output and undervoltage, alerting coupler output to emission	
CLISTATE+	Positive port of alert signal of overload, alerting coupler output to collector	High resistance while module alert and low while normal.
CLISTATE-	Negative port of alert signal of overload undervoltage, alerting coupler output to emission	
CLICON	Current limit control	Externally connect constant current controlled circuit for the use of current limit charge of battery management
54V-	54V negative port of DC output	
54V+	54V positive port of DC output	
LS	Bus line of current share	

(2) Monitoring interface

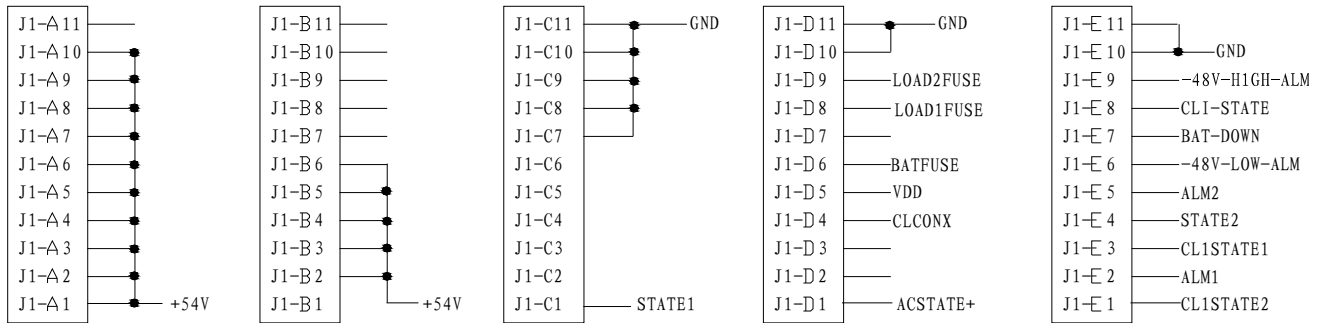

A1-A10: +54V is the positive terminal of the 54V DC input.

A11: empty,

B1,B7-B11: empty

B2-B6: +54V is the positive terminal of the 54V DC input

C1: STATE1 is the collector input of OPT on for the rectification module 1, high resistant when the module is disconnected while low electric level when connected

C2-C6: empty

C7-C11: GND is the negative terminal of the DC 54V input.

D1: ACSTATE+ is the emitter input of the warning OPT for AC power shut down, it should be high resistance in warning status and should be high electric level in normal operation

D2,D3: empty

D4: CLONX is the TTL electric level output for battery current limitation value control, high electric level would change it default value while low electric level keep it remain the same

D5: VDD is the 5V voltage output.

D6: BATFUSE is the TTL electric level input for battery fuse burn warning, high electric level for warning status and low electric level for normal operation.

D7: empty

D8: LOAD1FUSE is the 23V input for No. 1 circuit load fuse burn warning, 23V for warning status and low electric level for normal operation.

D9: LOAD2FUSE is the 23V input for No. 2 circuit load fuse burn warning, 23V for warning status and low electric level for normal operation.

D10,D11: GND is the negative terminal of 54V DC input.

E1: CLISTATE2 is the collector input of overload OPT for rectification module 2, high resistance for overload status and low electric level for normal operation

E2: ALM1 is the collector input of output warning OPT of rectification module 1, high resistance for warning status and low electric level for normal operation

E3: CLISTATE1 is the collector input of overload OPT for rectification module 1, high resistance for overload status and low electric level for normal operation

E4: STATE2 is the collector input of OPT on for the rectification module 2, high resistant when the module

is disconnected while low electric level when connected

E5: ALM2 is the collector input of output warning OPT of rectification module 2, high resistance for warning status and low electric level for normal operation

E6: -48V-LOW-ALM is the TTL electric level input for DC undervoltage warning, low electrical level for warning status and high electric level for normal operation

E7: BAT-DOWN is the TTL electric level input for battery shut down, low electric level for battery on and high electric level for battery down.

E8: CLI-STATE is the TTL electric level input for battery current limitation status, low electric level for current limitation and high electric level for normal operation

E9: -48V-HIGH-ALM is the TTL electric level input for DC overvoltage warning, low electric level for warning status and high electric level for normal operation.

E10,E11: GND is the negative terminal for 54V DC input

(3) DC distribution module connector definition

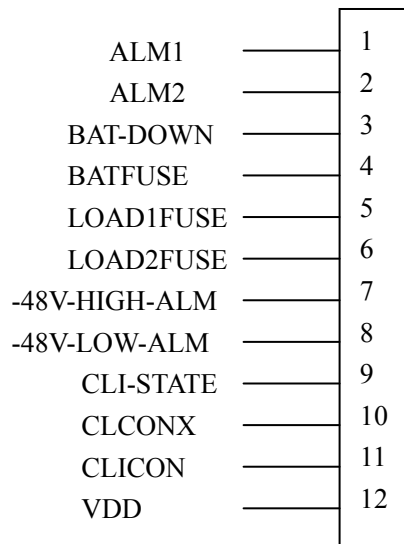

1. ALM1 is the collector input of output warning OPT of rectification module 1, high resistance for warning status and low electric level for normal operation

2. ALM2 is the collector input of output warning OPT of rectification module 2, high resistance for warning status and low electric level for normal operation

3. BAT-DOWN is the TTL electric level output for battery shut down, low electric level for battery on and high electric level for battery down

4. BATFUSE is the TTL electric level output for battery fuse burn warning, high electric level for warning status and low electric level for normal operation

5. LOAD1FUSE is the 23V output for No. 1 circuit load fuse burn warning, 23V for warning status and low electric level for normal operation.

6. LOAD2FUSE is the 23V output for No. 2 circuit load fuse burn warning, 23V for warning status and low electric level for normal operation.

7. -48V-HIGH-ALM is the TTL electric level output for DC overvoltage warning, low electric level for warning status and high electric level for normal operation.
8. -48V-LOW-ALM is the TTL electric level output for DC undervoltage warning, low electrical level for warning status and high electric level for normal operation
9. CLI-STATE is the TTL electric level output for battery current limitation status, low electric level for current limitation and high electric level for normal operation
10. CLONX is the TTL electric level input for battery current limitation value control, high electric level would change it default value while low electric level keep it remain the same
11. CLICON is the output signal for module current limitation control. Closed-loop control. No current limitation when in 0V status and current limitation takes effect when voltage >0
12. VDD is the 5V voltage input.

6. Power distribution requirement

This system has one three-core AC input socket for two AC power modules connected by back panel. Outputs are combined at back panel then output to two DC output ports and battery charging port via public voltage bus line. Slow-fusion fuse at each output port and battery charging loop is needed.

7. Requirements of ventilation channel and air speed

Each rectifier module has two 40mm fans itself on the front panel by induced draft from one side to another of the system forming ventilation channel. Air intake should be dust-proofed.

XI. Package, Transportation and Storage

1. Package

There are product name, model, making of manufacturer, safety approval, manufacturing date on the package box, and manual of specifications and packing list in the package box.

Huawei appointed English-Chinese label showed as below must be stuck on the package box.

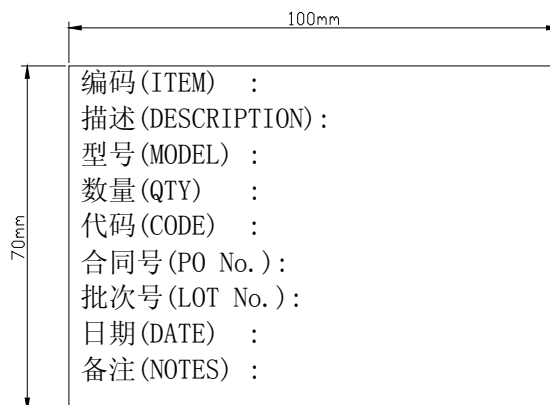

2. Transportation

Suit for transportation by truck, ship, and plane. The products should be shielded by tent from sunshine, and loaded and unloaded carefully.

3. Storage

Products should be stored in package box when it is not used. And warehouse temperature should

be -10°C — $+40^{\circ}\text{C}$, and relative humidity is 5%—80%. In the warehouse, there should not be harmful gas, inflammable, explosive products, and corrosive chemical products, and strong mechanical vibration, shock and strong magnetic field affection. The package box should be over ground at least 20cm height, and 50cm away from wall, thermal source, and vent. Under this requirement, product has 2 years of storage period, and should be rechecked when over 2 years.

XII. Reliability Requirements

1. MTBF \geq 150Khours(BELLCORE TR-NWT-332) 25 $^{\circ}\text{C}$ room temperature, resistance load
2. Yearly patch rate \leq 1%
3. Lifespan of electrolytic capacitor:10 years under temperature of 40 $^{\circ}\text{C}$ and full-sealed condition.

XIII. Attentions

1. First check if rated AC input voltage accord with that of power supply frame & rectifier module under operation condition
2. It is forbidden to turn on the power supply when AC voltage is above 280VAC or less than 85VAC
3. Regularly check running status of the fan to recognize if there's abnormal noise of fan, uneven turn speed and ventilation choke. Any of above abnormal status should be eliminated.
4. There should be more than 100mm space at both left and right side of power system to keep good ventilation.
5. Negative port of battery must be connected to BAT- and positive to BAT+. Do avoid connect negative port at 48V+ and 48V- port, or it will result in lifespan-shortening caused by over-charge/discharge of battery. Load has to be inserted before the connection of the battery.
6. Do not touch while operation due to danger.