

DDR4 SDRAM RDIMM Addendum

MTA18ASF4G72PDZ – 32GB

Introduction

Information provided here is in addition to or supersedes information provided in the Micron DDR4 RDIMM Core data sheet.

Features

- DDR4 functionality and operations supported as defined in the component data sheet
- Features and specifications defined in the Micron DDR4 RDIMM core data sheet
- 288-pin, registered dual in-line memory module (RDIMM)
- Fast data transfer rates: PC4-3200, PC4-2933
- 32GB (4 Gig × 72)
- Data bus inversion (DBI) for data bus
- Dual-rank
- 16 internal banks; 4 groups of 4 banks each

Figure 1: 288-Pin RDIMM (MO-309, R/C-E3)

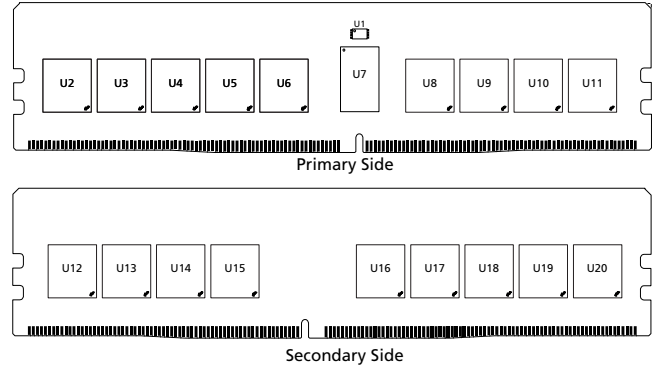

Options

- Operating temperature
 - Commercial ($0^{\circ}\text{C} \leq T_{\text{OPER}} \leq 95^{\circ}\text{C}$)
- Package
 - 288-pin DIMM (Green)
- Frequency/CAS latency
 - 0.625ns @ CL = 22 (DDR4-3200)
 - 0.682ns @ CL = 21 (DDR4-2933)

Marking

None
Z
-3G2
-2G9

Table 1: Addressing

Parameter	32GB
Row address	128K A[16:0]
Column address	1K A[9:0]
Device bank group address	4 BG[1:0]
Device bank address per group	4 BA[1:0]
Device configuration	16Gb (2 Gig × 8), 16 banks
Module rank address	2 CS_n[1:0]

Table 2: Part Numbers and Timing Parameters – 32GB Modules

Base device: MT40A2G8,¹ 16Gb DDR4 SDRAM

Part Number ²	Module Density	Configuration	Module Bandwidth	Memory Clock/ Data Rate	Clock Cycles (CL-nRCD-nRP)
MTA18ASF4G72PDZ-3G2__	32GB	4 Gig × 72	25.6 GB/s	0.625ns/3200 MT/s	22-22-22
MTA18ASF4G72PDZ-2G9__	32GB	4 Gig × 72	23.47 GB/s	0.682ns/2933 MT/s	21-21-21

- Notes:
1. The data sheet for the base device can be found on micron.com.
 2. All part numbers end with a two-place code (not shown) that designates component and PCB revisions. Consult factory for current revision codes. Example: MTA18ASF4G72PDZ-3G2B1.

Important Notes and Warnings

Micron Technology, Inc. ("Micron") reserves the right to make changes to information published in this document, including without limitation specifications and product descriptions. This document supersedes and replaces all information supplied prior to the publication hereof. You may not rely on any information set forth in this document if you obtain the product described herein from any unauthorized distributor or other source not authorized by Micron.

Automotive Applications. Products are not designed or intended for use in automotive applications unless specifically designated by Micron as automotive-grade by their respective data sheets. Distributor and customer/distributor shall assume the sole risk and liability for and shall indemnify and hold Micron harmless against all claims, costs, damages, and expenses and reasonable attorneys' fees arising out of, directly or indirectly, any claim of product liability, personal injury, death, or property damage resulting directly or indirectly from any use of non-automotive-grade products in automotive applications. Customer/distributor shall ensure that the terms and conditions of sale between customer/distributor and any customer of distributor/customer (1) state that Micron products are not designed or intended for use in automotive applications unless specifically designated by Micron as automotive-grade by their respective data sheets and (2) require such customer of distributor/customer to indemnify and hold Micron harmless against all claims, costs, damages, and expenses and reasonable attorneys' fees arising out of, directly or indirectly, any claim of product liability, personal injury, death, or property damage resulting from any use of non-automotive-grade products in automotive applications.

Critical Applications. Products are not authorized for use in applications in which failure of the Micron component could result, directly or indirectly in death, personal injury, or severe property or environmental damage ("Critical Applications"). Customer must protect against death, personal injury, and severe property and environmental damage by incorporating safety design measures into customer's applications to ensure that failure of the Micron component will not result in such harms. Should customer or distributor purchase, use, or sell any Micron component for any critical application, customer and distributor shall indemnify and hold harmless Micron and its subsidiaries, subcontractors, and affiliates and the directors, officers, and employees of each against all claims, costs, damages, and expenses and reasonable attorneys' fees arising out of, directly or indirectly, any claim of product liability, personal injury, or death arising in any way out of such critical application, whether or not Micron or its subsidiaries, subcontractors, or affiliates were negligent in the design, manufacture, or warning of the Micron product.

Customer Responsibility. Customers are responsible for the design, manufacture, and operation of their systems, applications, and products using Micron products. ALL SEMICONDUCTOR PRODUCTS HAVE INHERENT FAILURE RATES AND LIMITED USEFUL LIVES. IT IS THE CUSTOMER'S SOLE RESPONSIBILITY TO DETERMINE WHETHER THE MICRON PRODUCT IS SUITABLE AND FIT FOR THE CUSTOMER'S SYSTEM, APPLICATION, OR PRODUCT. Customers must ensure that adequate design, manufacturing, and operating safeguards are included in customer's applications and products to eliminate the risk that personal injury, death, or severe property or environmental damages will result from failure of any semiconductor component.

Limited Warranty. In no event shall Micron be liable for any indirect, incidental, punitive, special or consequential damages (including without limitation lost profits, lost savings, business interruption, costs related to the removal or replacement of any products or rework charges) whether or not such damages are based on tort, warranty, breach of contract or other legal theory, unless explicitly stated in a written agreement executed by Micron's duly authorized representative.



DQ Map

Table 3: Component-to-Module DQ Map

Component Reference Number	Component DQ	Module DQ	Module Pin Number	Component Reference Number	Component DQ	Module DQ	Module Pin Number
U2	0	3	157	U3	0	11	168
	1	0	5		1	8	16
	2	2	12		2	10	23
	3	1	150		3	9	161
	4	7	155		4	15	166
	5	4	3		5	12	14
	6	6	10		6	14	21
	7	5	148		7	13	159
U4	0	19	179	U5	0	27	190
	1	16	27		1	24	38
	2	18	34		2	26	45
	3	17	172		3	25	183
	4	23	177		4	31	188
	5	20	25		5	28	36
	6	22	32		6	30	43
	7	21	170		7	29	181
U6	0	CB3	201	U8	0	35	249
	1	CB0	49		1	32	97
	2	CB2	56		2	34	104
	3	CB1	194		3	33	242
	4	CB7	199		4	39	247
	5	CB4	47		5	36	95
	6	CB6	54		6	38	102
	7	CB5	192		7	37	240
U9	0	43	260	U10	0	51	271
	1	40	108		1	48	119
	2	42	115		2	50	126
	3	41	253		3	49	264
	4	47	258		4	55	269
	5	44	106		5	52	117
	6	46	113		6	54	124
	7	45	251		7	53	262
U11	0	59	282	U12	0	56	130
	1	56	130		1	59	282
	2	58	137		2	57	275
	3	57	275		3	58	137
	4	63	280		4	60	128
	5	60	128		5	63	280
	6	62	135		6	61	273
	7	61	273		7	62	135



Table 3: Component-to-Module DQ Map (Continued)

Component Reference Number	Component DQ	Module DQ	Module Pin Number	Component Reference Number	Component DQ	Module DQ	Module Pin Number
U13	0	48	119	U14	0	40	108
	1	51	271		1	43	260
	2	49	264		2	41	253
	3	50	126		3	42	115
	4	52	117		4	44	106
	5	55	269		5	47	258
	6	53	262		6	45	251
	7	54	124		7	46	113
U15	0	32	97	U16	0	CB0	49
	1	35	249		1	CB3	201
	2	33	242		2	CB1	194
	3	34	104		3	CB2	56
	4	36	95		4	CB4	47
	5	39	247		5	CB7	199
	6	37	240		6	CB5	192
	7	38	102		7	CB6	54
U17	0	24	38	U18	0	16	27
	1	27	190		1	19	179
	2	25	183		2	17	172
	3	26	45		3	18	34
	4	28	36		4	20	25
	5	31	188		5	23	177
	6	29	181		6	21	170
	7	30	43		7	22	32
U19	0	8	16	U20	0	0	5
	1	11	168		1	3	157
	2	9	161		2	1	150
	3	10	23		3	2	12
	4	12	14		4	4	3
	5	15	166		5	7	155
	6	13	159		6	5	148
	7	14	21		7	6	10

I_{DD} Specifications

Table 4: DDR4 I_{DD} Specifications and Conditions – 32GB (Die Revision E)

Values are for the MT40A2G8 DDR4 SDRAM only and are computed from values specified in the 16Gb (2 Gig × 8) component data sheet.

Parameter	Symbol	3200	2933	Units
One bank ACTIVATE-PRECHARGE current	I _{DD0} ¹	882	873	mA
One bank ACTIVATE-PRECHARGE, wordline boost, I _{pp} current	I _{PP0} ¹	45	45	mA
One bank ACTIVATE-READ-PRECHARGE current	I _{DD1} ¹	981	972	mA
Precharge standby current	I _{DD2N} ²	810	792	mA
Precharge standby ODT current	I _{DD2NT} ¹	801	792	mA
Precharge power-down current	I _{DD2P} ²	684	684	mA
Precharge quiet standby current	I _{DD2Q} ²	756	756	mA
Active standby current	I _{DD3N} ²	1098	1080	mA
Active standby I _{pp} current	I _{PP3N} ²	36	36	mA
Active power-down current	I _{DD3P} ²	900	882	mA
Burst read current	I _{DD4R} ¹	1800	1728	mA
Burst write current	I _{DD4W} ¹	1494	1449	mA
Different logic rank burst refresh current (1x REF)	I _{DD5R} ¹	954	954	mA
Different logic rank burst refresh I _{pp} current (1x REF)	I _{PP5R} ¹	54	54	mA
Self refresh current: Normal temperature range (0°C to 85°C)	I _{DD6N (0-85°C)} ²	954	954	mA
Self refresh current: Extended temperature range (0°C to 95°C)	I _{DD6E (0-95°C)} ²	2034	2034	mA
Self refresh current: Reduced temperature range (0°C to 45°C)	I _{DD6R (0-45°C)} ²	360	360	mA
Auto self refresh current (25°C)	I _{DD6A (25°C)} ²	198	198	mA
Auto self refresh current (45°C)	I _{DD6A (45°C)} ²	360	360	mA
Auto self refresh current (75°C)	I _{DD6A (75°C)} ²	918	918	mA
Auto self refresh current (95°C)	I _{DD6A (95°C)} ²	2034	2034	mA
Auto self refresh I _{pp} current (0°C to 95°C)	I _{PP6X} ²	108	108	mA
Bank interleave read current	I _{DD7} ¹	2007	1989	mA
Bank interleave read I _{pp} current	I _{PP7} ¹	144	144	mA
Maximum power-down current	I _{DD8} ²	648	648	mA

- Notes: 1. One module rank in the active I_{DD/PP}, the other rank in I_{DD2P/PP3N}.
2. All ranks in this I_{DD/PP} condition.

Table 5: DDR4 I_{DD} Specifications and Conditions – 32GB (Die Revision B)

Values are for the MT40A2G8 DDR4 SDRAM only and are computed from values specified in the 16Gb (2 Gig x 8) component data sheet.

Parameter	Symbol	3200	2933	Units
One bank ACTIVATE-PRECHARGE current	I _{DD0} ¹	954	945	mA
One bank ACTIVATE-PRECHARGE, wordline boost, I _{PP} current	I _{PP0} ¹	63	63	mA
One bank ACTIVATE-READ-PRECHARGE current	I _{DD1} ¹	1053	1044	mA
Precharge standby current	I _{DD2N} ²	936	918	mA
Precharge standby ODT current	I _{DD2NT} ¹	891	882	mA
Precharge power-down current	I _{DD2P} ²	774	774	mA
Precharge quiet standby current	I _{DD2Q} ²	846	846	mA
Active standby current	I _{DD3N} ²	1440	1422	mA
Active standby I _{PP} current	I _{PP3N} ²	54	54	mA
Active power-down current	I _{DD3P} ²	1242	1242	mA
Burst read current	I _{DD4R} ¹	2205	2115	mA
Burst write current	I _{DD4W} ¹	2034	1962	mA
Different logic rank burst refresh current (1x REF)	I _{DD5R} ¹	1098	1089	mA
Different logic rank burst refresh I _{PP} current (1x REF)	I _{PP5R} ¹	72	72	mA
Self refresh current: Normal temperature range (0°C to 85°C)	I _{DD6N (0-85°C)} ²	1206	1206	mA
Self refresh current: Extended temperature range (0°C to 95°C)	I _{DD6E (0-95°C)} ²	2178	2178	mA
Self refresh current: Reduced temperature range (0°C to 45°C)	I _{DD6R (0-45°C)} ²	522	522	mA
Auto self refresh current (25°C)	I _{DD6A (25°C)} ²	180	180	mA
Auto self refresh current (45°C)	I _{DD6A (45°C)} ²	522	522	mA
Auto self refresh current (75°C)	I _{DD6A (75°C)} ²	1098	1098	mA
Auto self refresh current (95°C)	I _{DD6A (95°C)} ²	2178	2178	mA
Auto self refresh I _{PP} current (0°C to 95°C)	I _{PP6X} ²	198	198	mA
Bank interleave read current	I _{DD7} ¹	2151	2124	mA
Bank interleave read I _{PP} current	I _{PP7} ¹	117	117	mA
Maximum power-down current	I _{DD8} ²	720	720	mA

- Notes: 1. One module rank in the active I_{DD/PP}, the other rank in I_{DD2P/PP3N}.
2. All ranks in this I_{DD/PP} condition.

Functional Block Diagram

Figure 2: Functional Block Diagram

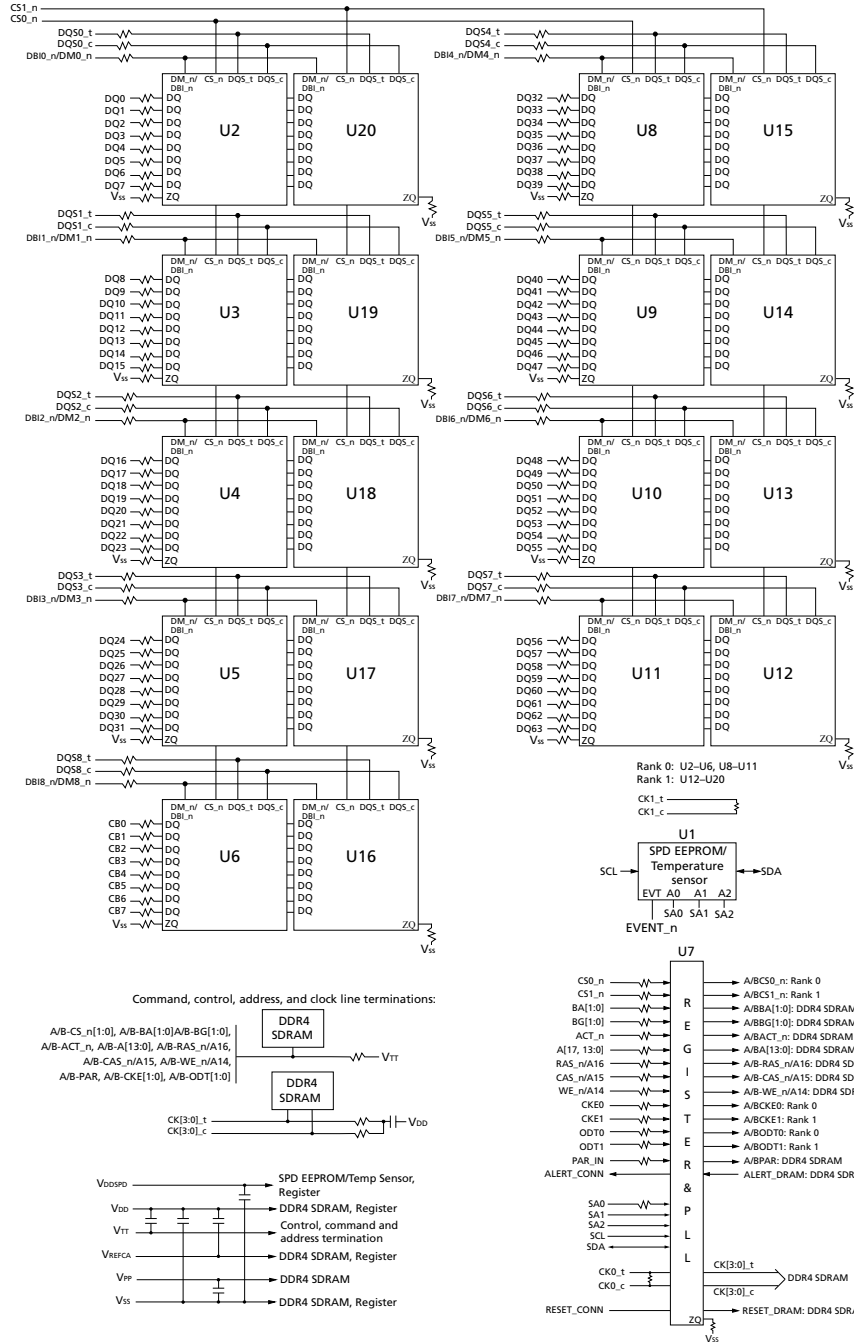

Note: 1. The ZQ ball on each DDR4 component is connected to an external $240\Omega \pm 1\%$ resistor that is tied to ground. It is used for the calibration of the component's ODT and output driver.



32GB (x72, ECC, DR) 288-Pin DDR4 RDIMM Functional Block Diagram

8000 S. Federal Way, P.O. Box 6, Boise, ID 83707-0006, Tel: 208-368-4000
www.micron.com/products/support Sales inquiries: 800-932-4992
Micron and the Micron logo are trademarks of Micron Technology, Inc.
All other trademarks are the property of their respective owners.

This data sheet contains minimum and maximum limits specified over the power supply and temperature range set forth herein.
Although considered final, these specifications are subject to change, as further product development and data characterization some-
times occur.

Mouser Electronics

Authorized Distributor

Click to View Pricing, Inventory, Delivery & Lifecycle Information:

[Micron Technology:](#)

[MTA18ASF4G72PDZ-2G9B1](#) [MTA18ASF4G72PDZ-3G2B2](#) [MTA18ASF4G72PDZ-2G9B2](#) [MTA18ASF4G72PDZ-2G9E1](#) [MTA18ASF4G72PDZ-3G2E1](#)