

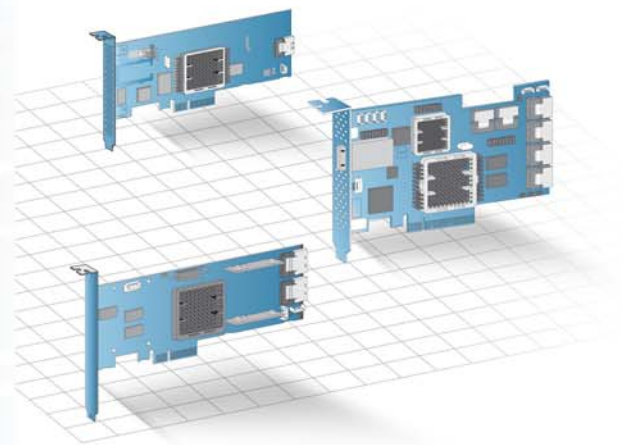

# Serial Attached SCSI RAID Controllers **Installation and User's Guide**



## **Copyright**

Copyright © 2011 PMC-Sierra, Inc. All rights reserved.

The information in this document is proprietary and confidential to PMC-Sierra, Inc., and for its customers' internal use. In any event, no part of this document may be reproduced or redistributed in any form without the express written consent of PMC-Sierra, Inc.

## **Trademarks**

PMC, PMC-Sierra, and Adaptec are registered trademarks of PMC-Sierra, Inc. "Adaptec by PMC" is a trademark of PMC-Sierra, Inc. Other product and company names mentioned herein may be trademarks of their respective owners. For a complete list of PMC-Sierra trademarks, see [www.pmc-sierra.com/legal](http://www.pmc-sierra.com/legal).

## **Disclaimer**

None of the information contained in this document constitutes an express or implied warranty by PMC-Sierra, Inc. as to the sufficiency, fitness or suitability for a particular purpose of any such information or the fitness, or suitability for a particular purpose, merchantability, performance, compatibility with other parts or systems, of any of the products of PMC-Sierra, Inc., or any portion thereof, referred to in this document. PMC-Sierra, Inc. expressly disclaims all representations and warranties of any kind regarding the contents or use of the information, including, but not limited to, express and implied warranties of accuracy, completeness, merchantability, fitness for a particular use, or non-infringement. In no event will PMC-Sierra, Inc. be liable for any direct, indirect, special, incidental or consequential damages, including, but not limited to, lost profits, lost business or lost data resulting from any use of or reliance upon the information, whether or not PMC-Sierra, Inc. has been advised of the possibility of such damage.

## **Patents**

The technology discussed in this document may be protected by one or more patent grants.

---

## Adaptec by PMC Product Support

If you have questions about installing or using your Adaptec by PMC product, check this document first—you will find answers to most of your questions. If you need further assistance, use the support options listed below. To expedite your service, have your computer in front of you.

### Technical Support Identification (TSID) Number

- Before contacting Technical Support, you need your product unique TSID number. The TSID number identifies your product and support status.
- The TSID number is included on a white, bar-coded label, like this example:

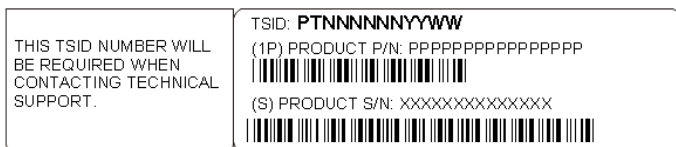

- It's recommended that you register your product so that you have easy access to your TSID when contacting product support.

**Note:** The phone numbers below are subject to change. Please visit the Support section of [www.adaptec.com](http://www.adaptec.com) for the most up to date contact information.

### North America

- Visit our Web site at [www.adaptec.com](http://www.adaptec.com).
- Search the Adaptec Support Knowledgebase (ASK) at [ask.adaptec.com](http://ask.adaptec.com) for articles, troubleshooting tips, and frequently asked questions for your product.
- For information about Adaptec by PMC support options, call +1 408-957-2550, 24 hours per day, 7 days per week. To speak with a Technical Support Specialist, call +1 408-934-7274.
- For support via e-mail, submit your question at [ask.adaptec.com](mailto:ask.adaptec.com).
- You can order Adaptec by PMC products, including accessories and cables, by calling +1 408-957-7274. Or, you can order cables online at [www.adaptec.com/en-us/products/cables](http://www.adaptec.com/en-us/products/cables).

### Europe

- Visit our Web site at [www.adaptec-europe.com](http://www.adaptec-europe.com).
- **German:** Call +49 89 43 66 55 22. For support via e-mail, submit your question at [ask-de.adaptec.com](mailto:ask-de.adaptec.com).
- **French:** Call +49 89 43 66 55 33. For support via e-mail, submit your question at [ask-fr.adaptec.com](mailto:ask-fr.adaptec.com).
- **English:** Call +49 89 43 66 55 44. For support via e-mail, submit your question at [ask.adaptec.com](mailto:ask.adaptec.com).
- You can order Adaptec cables online at [www.adaptec.com/en-us/products/cables](http://www.adaptec.com/en-us/products/cables).

### Japan

- Visit our Web site at [www.adaptec.co.jp](http://www.adaptec.co.jp).
- Call +0066-3313-2601.

### Australia

- Call +61-2-9503-1555.

### Limited 3-Year Hardware Warranty

1. PMC-Sierra, Inc. (“PMC-Sierra”) warrants to the purchaser of this product that it will be free from defects in material and workmanship for a period of three (3) years from the date of purchase. If the product should become defective within the warranty period, PMC-Sierra, at its option, will repair or replace the product, or refund the purchaser’s purchase price for the product, provided it is delivered at the purchaser’s expense to an authorized PMC-Sierra service facility or to PMC-Sierra.
2. Repair or replacement parts or products will be furnished on an exchange basis and will either be new or reconditioned. All replaced parts or products shall become the property of PMC-Sierra. This warranty shall not apply if the product has been damaged by accident, misuse, abuse or as a result of unauthorized service or parts.
3. Warranty service is available to the purchaser by delivering the product during the warranty period to an authorized PMC-Sierra service facility or to PMC-Sierra and providing proof of purchase price and date. The purchaser shall bear all shipping, packing and insurance costs and all other costs, excluding labor and parts, necessary to effectuate repair, replacement or refund under this warranty.
4. For more information on how to obtain warranty service, write or telephone PMC-Sierra, Inc. at 1380 Bordeaux Drive Sunnyvale, CA 94089, (408) 239-8000.
5. THIS LIMITED WARRANTY DOES NOT EXTEND TO ANY PRODUCT WHICH HAS BEEN DAMAGED AS A RESULT OF ACCIDENT, MISUSE, ABUSE, OR AS A RESULT OF UNAUTHORIZED SERVICE OR PARTS.
6. THIS WARRANTY IS IN LIEU OF ALL OTHER EXPRESS WARRANTIES WHICH NOW OR HEREAFTER MIGHT OTHERWISE ARISE RESPECT TO THIS PRODUCT. IMPLIED WARRANTIES, INCLUDING THOSE OF MERCHANTABILITY, FITNESS FOR A PARTICULAR PURPOSE AND NON-INFRINGEMENT SHALL (A) HAVE NO GREATER DURATION THAN 3 YEARS FROM THE DATE OF PURCHASE, (B) TERMINATE AUTOMATICALLY AT THE EXPIRATION OF SUCH PERIOD AND (C) TO THE EXTENT PERMITTED BY LAW BE EXCLUDED. IN THE EVENT THIS PRODUCT BECOMES DEFECTIVE DURING THE WARRANTY PERIOD, THE PURCHASER’S EXCLUSIVE REMEDY SHALL BE REPAIR, REPLACEMENT OR REFUND AS PROVIDED ABOVE. INCIDENTAL OR CONSEQUENTIAL DAMAGES, INCLUDING WITHOUT LIMITATION LOSS OF DATA, ARISING FROM BREACH OF ANY EXPRESS OR IMPLIED WARRANTY ARE NOT THE RESPONSIBILITY OF PMC-SIERRA AND, TO THE EXTENT PERMITTED BY LAW, ARE HEREBY EXCLUDED BOTH FOR PROPERTY DAMAGE, AND TO THE EXTENT NOT UNCONSCIONABLE, FOR PERSONAL INJURY DAMAGE.
7. SOME STATES DO NOT ALLOW THE EXCLUSION OR LIMITATION OF INCIDENTAL OR CONSEQUENTIAL DAMAGES FOR CONSUMER PRODUCTS, AND SOME STATES DO NOT ALLOW LIMITATIONS ON HOW LONG AN IMPLIED WARRANTY LASTS, SO THE ABOVE LIMITATION OR EXCLUSIONS MAY NOT APPLY TO YOU.
8. This warranty gives you specific legal rights, and you may also have other rights which vary from state to state.

## Regulatory Compliance Statements

### Federal Communications Commission Radio Frequency Interference Statement

WARNING: Changes or modifications to this unit not expressly approved by the party responsible for compliance could void the user's authority to operate the equipment.

This equipment has been tested and found to comply with the limits for a Class B digital device, pursuant to Part 15 of the FCC rules. These limits are designed to provide reasonable protection against harmful interference in a residential installation. This equipment generates, uses, and can radiate radio frequency energy, and if not installed and used in accordance with the instruction manual, may cause harmful interference to radio communications. However, there is no guarantee that interference will not occur in a particular installation. However, if this equipment does cause interference to radio or television equipment reception, which can be determined by turning the equipment off and on, the user is encouraged to try to correct the interference by one or more of the following measures:

- Reorient or relocate the receiving antenna.
- Increase the separation between equipment and receiver.
- Connect the equipment to an outlet on a circuit different from that to which the receiver is connected.
- Consult the dealer or an experienced radio/television technician for help.
- Use a shielded and properly grounded I/O cable and power cable to ensure compliance of this unit to the specified limits of the rules.

This device complies with part 15 of the FCC rules. Operation is subject to the following two conditions: (1) this device may not cause harmful interference and (2) this device must accept any interference received, including interference that may cause undesired operation.

### UL Compliance Statement



Adaptec by PMC products are tested and listed by Underwriters Laboratories, Inc. to UL 60950-1 Second Edition and IEC-60950-1 Second Edition standards, file numbers E175975. Adaptec by PMC products are for use only with UL listed ITE.

PMC-Sierra, Inc.	<b>Use only with the listed ITE:</b>
Adaptec RAID 5085/Adaptec RAID 5405/Adaptec RAID 5445/ Adaptec RAID 5805/ Adaptec RAID 5405Z/Adaptec RAID 5805Z/Adaptec RAID 5445Z/ Adaptec RAID 5805Q/Adaptec RAID 5805ZQ/ Adaptec RAID 51245/Adaptec RAID 51645/Adaptec RAID 52445/ Adaptec RAID 2045/Adaptec RAID 2405/Adaptec RAID 2405Q/ Adaptec RAID 2805/ Adaptec RAID 6405/Adaptec RAID 6445/Adaptec RAID 6805/ Adaptec RAID 6405E/Adaptec RAID 6805E/Adaptec RAID 6805Q/ Adaptec RAID 6405T/Adaptec RAID 6805T/Adaptec RAID 6805TQ	
 Tested to Comply With FCC Standards	
FOR HOME OR OFFICE USE	



### European Union Compliance Statement

This Information Technology Equipment has been tested and found to comply with EMC Directive 89/336/EEC, as amended by 92/31/EEC and 93/68/EEC, in accordance with:

- EN55022 (1998+A1:2000+A2:2003) Emissions
- EN55024 (1998+A1:2001+A2:2003) Immunity:
  - EN61000-4-2 (1995) Electrostatic discharge: ±4 kV contact, ±8 kV air
  - EN61000-4-3 (1996) Radiated immunity
  - EN61000-4-4 (1995) Electrical fast transients/burst: ±1 kV AC, ±0.5 kV I/O
  - EN61000-4-5 (1995) Surges ±1 kV differential mode, ±2 kV common mode
  - EN61000-4-6 (1996) Conducted immunity: 3 V
  - EN61000-4-11 (1994) Supply dips and variation: 30% and 100%

In addition, all equipment requiring U.L. listing has been found to comply with EMC Directive 73/23/EEC as amended by 93/68/EEC in accordance with EN60950 with amendments A1, A2, A3, A4, A11.



### Australian/New Zealand Compliance Statement

This device has been tested and found to comply with the limits for a Class B digital device, pursuant to the Australian/New Zealand standard AS/NZS 3548 set out by the Spectrum Management Agency.



### Canadian Compliance Statement

This Class B digital apparatus meets all requirements of the Canadian Interference-Causing Equipment Regulations. Cet appareil numérique de la classe B respecte toutes les exigences du Règlement sur le matériel brouilleur du Canada.



### Japanese Compliance (Voluntary Control Council Initiative)

This equipment complies to class B Information Technology equipment based on VCCI (Voluntary Control Council for Interface). This equipment is designed for home use but it may cause radio frequency interference problem if used too near to a television or radio. Please handle it correctly per this documentation.

**Korean Compliance (KCC) Statement**

Adaptec by PMC products are tested and certified by KCC:  
KCC-REM-KHK-ASR-6xx5

The above certification covers the following series:

ASR-6805, ASR-6445, ASR-6405  
ASR-6805E, ASR-6405E, ASR-6805Q  
ASR-6805T, ASR-6405T, ASR-6805TQ

**B급 기기**

(가정용 방송통신기자재)

**Class B Equipment**

**(For Home Use Broadcasting & Communication Equipment)**

이 기기는 가정용(B급) 전자파적합기기로서 주로 가정에서 사용하는 것을 목적으로 하며, 모든 지역에서 사용할 수 있습니다.

This equipment is home use (Class B) electromagnetic wave suitability equipment and to be used mainly at home and it can be used in all areas.



**Caution:** Risk of explosion if the battery is replaced by an incorrect type. Dispose of used batteries according to the instructions.

# Contents

---

<b>1</b>	<b>About This Guide</b>	
	What You Need to Know Before You Begin .....	13
	Terminology Used in this Guide .....	13
	How to Find More Information.....	13
<b>2</b>	<b>Kit Contents and System Requirements</b>	
	Kit Contents .....	15
	System Requirements.....	15
<b>3</b>	<b>About Your RAID Controller</b>	
	Standard RAID Controller Features .....	18
	Array-level Features .....	18
	Advanced Data Protection Suite .....	19
	Adding a Battery Backup Module .....	19
	Adding a Flash Backup Module .....	19
	Upgrading the Controller Firmware .....	19
	About the Adaptec RAID 5085.....	20
	About the Adaptec RAID 5405.....	21
	About the Adaptec RAID 5445.....	22
	About the Adaptec RAID 5805/5805Q .....	23
	About the Adaptec RAID 51245.....	24
	About the Adaptec RAID 51645.....	25
	About the Adaptec RAID 52445.....	26
	About the Adaptec RAID 5405Z .....	27
	About the Adaptec RAID 5445Z .....	28
	About the Adaptec RAID 5805Z/5805ZQ .....	29
	About the Adaptec RAID 2045.....	30
	About the Adaptec RAID 2405/2405Q .....	31
	About the Adaptec RAID 2805.....	32
	About the Adaptec RAID 6405.....	33

---

About the Adaptec RAID 6445.....	34
About the Adaptec RAID 6805/6805Q .....	35
About the Adaptec RAID 6405E .....	36
About the Adaptec RAID 6805E .....	37
About the Adaptec RAID 6405T .....	38
About the Adaptec RAID 6805T/6805TQ .....	39
<b>4 Getting Started</b>	
Choosing a RAID Level.....	41
Selecting Disk Drives and Cables .....	42
Disk Drives .....	42
Cables .....	42
Replacing the Full-Height Bracket with a Low-Profile Bracket.....	43
Installation Options .....	45
Basic Installation Steps.....	45
Installing with an Operating System.....	45
Installing on an Existing Operating System .....	45
<b>5 Installing the Controller and Disk Drives</b>	
Before You Begin.....	47
Installing the Controller .....	47
Installing a RAID Controller.....	47
Installing a RAID Controller with Zero Maintenance Cache Protection	48
Connecting Disk Drives to Your Controllers .....	50
Connecting Drives Directly to the Controller.....	50
Connecting Drives to a System Backplane .....	51
Connecting Solid State Drives (SSDs) .....	52
Connecting External Devices.....	53
Next Steps.....	53
<b>6 Creating a Bootable Array</b>	
Setting the Boot Controller .....	55
Creating an Array.....	55
Creating an Array with the ACU .....	55
Creating an Array with Adaptec Storage Manager .....	57
Making Your Array Bootable .....	58
<b>7 Installing the Driver and an Operating System</b>	
Before You Begin.....	60
Creating a Driver Disk.....	60
Installing with Windows.....	61
Installing with Windows Server 2003 .....	61
Installing with Windows Server 2008, Windows 7, or Windows Vista ...	61
Installing with Red Hat Linux 5 .....	62

---



---

Installing with Red Hat Linux 6 or Fedora Linux .....	62
Installing with SuSE Linux .....	63
Installing with Debian Linux.....	63
Installing with Ubuntu Linux.....	65
Installing with Solaris.....	67
Installing with VMware ESX 4 .....	67
Installing with VMware ESXi 5 .....	68
Installing with FreeBSD .....	71
<b>8 Installing the Driver on an Existing Operating System</b>	
Before You Begin.....	73
Creating a Driver Disk .....	73
Installing on Windows.....	74
Installing on Windows Server 2003 .....	74
Installing on Windows Server 2008, Windows 7, or Windows Vista .....	74
Installing on Red Hat, SuSE, or Fedora Linux .....	74
Installing on Debian Linux.....	75
Installing on Ubuntu Linux.....	75
Installing on Solaris.....	76
Installing on VMware .....	76
Installing on FreeBSD .....	78
<b>9 Managing Your Storage Space</b>	
About Adaptec Storage Manager .....	80
Installing Adaptec Storage Manager .....	80
About the Adaptec RAID Controller Configuration Utility.....	80
About the Adaptec RAID Configuration Utility .....	81
About the Adaptec Flash Utility.....	81
Which Utility Should I Use? .....	81
Which Utility Should I Use on VMware? .....	81
<b>10 Solving Problems</b>	
Troubleshooting Checklist .....	84
Monitoring Disk Drives Status.....	84
Silencing the Alarm.....	84
Recovering from a Disk Drive Failure .....	85
Failed Disk Drive Protected by a Hot Spare .....	85
Failed Disk Drive <i>Not</i> Protected by a Hot Spare .....	85
Failure in Multiple Arrays Simultaneously.....	85
Disk Drive Failure in a RAID 0 Array.....	86
Multiple Failures in the Same Array .....	86
Failed Drive in maxCache Pool.....	86
Resetting the Controller.....	86

---

**A Introduction to SAS**

Terminology Used in This Chapter .....	89
What is SAS? .....	89
How Do SAS Devices Communicate?.....	90
What's a Phy? .....	90
What's a SAS Port? .....	91
What's a SAS Address? .....	91
What's a SAS Connector? .....	91
What do SAS Cables Look Like?.....	91
How are Disk Drives Identified in SAS? .....	92
What are the SAS Connection Options?.....	92
Direct-attach Connections .....	92
Backplane Connections .....	92
SAS Expander Connections.....	93
How is SAS Different from Parallel SCSI? .....	94

**B Understanding RAID**

Understanding Drive Segments .....	96
Non-redundant Arrays (RAID 0).....	96
RAID 1 Arrays .....	97
RAID 1 Enhanced Arrays.....	97
RAID 10 Arrays .....	98
RAID 5 Arrays .....	99
RAID 5EE Arrays.....	100
RAID 50 Arrays .....	101
RAID 6 Arrays .....	102
RAID 60 Arrays .....	102
Selecting the Best RAID Level .....	103

**C Using the Adaptec RAID Configuration Utility**

Introduction to the ARC Utility.....	105
Running the ARC Utility .....	105
Navigating the ARC Utility .....	105
Using the ACU to Create and Manage Arrays.....	105
Creating a New Array .....	105
Managing Existing Arrays .....	106
Initializing Disk Drives .....	108
Rescanning Disk Drives.....	108
Secure Erasing Disk Drives.....	108
Managing Global Hot Spares .....	108
Using the ACU to Create and Manage JBODs .....	109
Creating a New JBOD.....	109
Managing Existing JBODs.....	109
Using the ACU to Manage the maxCache Pool .....	109
Using SerialSelect to Modify Controller Settings.....	110

---

Opening SerialSelect.....	110
Applying Changes and Exiting.....	110
Modifying Your Controller's Configuration.....	110
Formatting and Verifying Disk Drives.....	113
Locating Disk Drives.....	113
Identifying Disk Drives.....	114
Viewing the Event Log.....	114
<b>D Using the Adaptec Flash Utility</b>	
System Requirements.....	116
Before You Begin.....	116
Obtaining the Firmware .....	116
Creating the Firmware Update Disks .....	117
Running the Menu-based AFU .....	117
Running the AFU from the Command Line .....	118
AFU Commands.....	118
Updating the Flash Using the AFU Command Line.....	121
<b>E Controller LED and I2C Connector Quick Reference</b>	
Adaptec RAID 5085 LED Connector Specification.....	123
Adaptec RAID 5405/5405Z LED and I2C Connector Specification .....	125
Adaptec RAID 5445/5445Z LED and I2C Connector Specification .....	126
Adaptec RAID 5805/5805Q/5805Z/5805ZQ LED and I2C Connector Specification .....	128
Adaptec RAID 51245 LED and I2C Connector Specification .....	130
Adaptec RAID 51645 LED and I2C Connector Specification .....	132
Adaptec RAID 52445 LED and I2C Connector Specification .....	134
Adaptec RAID 2045 LED Connector Specification.....	137
Adaptec RAID 2405/2405Q LED and I2C Connector Specification.....	137
Adaptec RAID 2805 LED and I2C Connector Specification .....	138
Adaptec RAID 6405/6445 LED and I2C Connector Specification.....	139
Adaptec RAID 6805/6805Q LED and I2C Connector Specification.....	141
Adaptec RAID 6405E LED Connector Specification .....	142
Adaptec RAID 6805E LED Connector Specification .....	143
Adaptec RAID 6405T LED Connector Specification .....	144
Adaptec RAID 6805T/6805TQ LED Connector Specification .....	145

---

**F Safety Information**

Electrostatic Discharge (ESD) ..... 147

**G Technical Specifications**

Environmental Specifications..... 149

DC Power Requirements ..... 149

Current Requirements ..... 149

**Index**

---

# About This Guide

# 1

## In this chapter...

What You Need to Know Before You Begin .....	13
Terminology Used in this Guide .....	13
How to Find More Information .....	13

This *Installation and User's Guide* explains how to install your Adaptec® by PMC™ RAID controller. It also describes the utilities included in your controller kit, and provides a basic overview of Serial Attached SCSI (SAS) and Redundant Array of Independent Disk (RAID) technology.

These RAID controller models are described in this guide:

- Adaptec RAID 5085
- Adaptec RAID 5405/5405Z
- Adaptec RAID 5445/5445Z
- Adaptec RAID 5805/5805Q/5805Z/5805ZQ
- Adaptec RAID 51245
- Adaptec RAID 51645
- Adaptec RAID 52445
- Adaptec RAID 2045
- Adaptec RAID 2405/2405Q
- Adaptec RAID 2805
- Adaptec RAID 6405/6405E/6405T
- Adaptec RAID 6445
- Adaptec RAID 6805/6805Q/6805E/6805T/6805TQ

## What You Need to Know Before You Begin

You should be familiar with computer hardware, data storage, RAID technology, and SAS and Serial ATA (SATA) technology. (For an introduction to SAS, see [page 88](#).)

You should also be familiar with Direct-Attached Storage (DAS) concepts and technology.

**Note:** Because this guide covers multiple Adaptec RAID products, some of the features and functions described may not be available for your controller. For more information, see [About Your RAID Controller on page 17](#).

## Terminology Used in this Guide

Because you can use your Adaptec RAID controller to manage data storage in a variety of configurations, the generic term “storage space” is used to refer to controller(s) and disk drives being managed with Adaptec Storage Manager™ or the other utilities described in this guide.

Many of the terms and concepts referred to in this guide are known to computer users by multiple names. This guide uses these terms:

- Controller (also known as adapter, board, or card)
- Disk drive (also known as hard disk, hard drive, or hard disk drive)
- Solid State Drive (also known as SSD or non-rotating storage media)
- Enclosure (also known as a RAID enclosure, storage enclosure, or JBOD enclosure)
- Array (also known as a container, logical device, or logical drive)

**Note:** Adaptec Storage Manager refers to arrays as logical drives. Your RAID controller creates *arrays*, which your operating system (and Adaptec Storage Manager) recognizes as *logical drives*. For more information, refer to the *Adaptec Storage Manager User's Guide* on the Adaptec Installation DVD.

## How to Find More Information

You can find more information about your Adaptec RAID controller and the software and utilities included with it by referring to these documents:

- *Readme.txt*—Includes updated product information and known issues; located on the Adaptec Installation DVD.
- *Adaptec Storage Manager User's Guide*—Describes how to install and use the Adaptec Storage Manager software (see [page 80](#)) to manage your direct attached storage; located on the Adaptec Installation DVD.
- *Adaptec Storage Manager Online Help*—Describes how to use the Adaptec Storage Manager software; accessible from the main window of Adaptec Storage Manager.
- *Adaptec RAID Controller Command Line Utility User's Guide*—Describes how to use the included Adaptec RAID Controller Configuration (ARCCONF) command line utility (see [page 80](#)) to perform basic array and configuration management functions; located on the Adaptec Installation DVD.

# Kit Contents and System Requirements

# 2

**In this chapter...**

Kit Contents..... 15

System Requirements..... 15

This chapter lists the contents of your Adaptec RAID controller kit and the system requirements that must be met for you to successfully install and use your controller.

## Kit Contents

- Adaptec by PMC RAID controller
- Adaptec Installation DVD (bootable), including controller drivers, Adaptec Storage Manager, ARCCONF command line utility, and documentation
- Cables (Not all kits contain cables. If your kit does, the type and quantity vary—for cable information about your controller, visit the Adaptec Web site at [www.adaptec.com](http://www.adaptec.com).)
- (*Selected models only*) Low-profile bracket
- *Adaptec Serial Attached SCSI RAID Controllers Quick Start Guide*

## System Requirements

- PC-compatible computer with Intel Pentium, or equivalent, processor
- Motherboard with these features:
  - Support for multifunction devices where one of the devices is a PCI bridge
  - Large memory-mapped address ranges

Refer to the Readme file on the Adaptec Installation DVD for additional motherboard compatibility information.

- One of these operating systems:

**Note:** For up-to-date operating system version support check the readme on the Adaptec Installation DVD or visit the Adaptec Web Site at [www.adaptec.com](http://www.adaptec.com).

- Microsoft® Windows® Server 2008 (32-bit and 64-bit), Windows Server 2008 R2 (64-bit), Windows Server 2003 (32-bit and 64-bit), Windows Server 2003 R2 (32-bit and 64-bit), Windows Vista, Windows 7
- Red Hat® Enterprise Linux 6.0, 5.5 (32-bit and 64-bit)
- SuSE Linux Enterprise Server 11, SuSE Linux Enterprise Server 10 (32-bit and 64-bit)
- FreeBSD 8.x, 7.x,
- Debian Linux 5, 6 (32-bit and 64-bit)
- Ubuntu Linux 10, 11 (32-bit and 64-bit)
- Fedora Linux 12, 13, 14 (32-bit and 64-bit)

**Note:** For the latest on Linux support or to download driver sources, visit the Support area of the Adaptec Web site at [www.adaptec.com](http://www.adaptec.com).

- Solaris 10, Solaris 11 Express
- VMware ESXi 5.0, VMware ESX 4.1 Classic

**Note:** VMware storage management options vary, depending on which version of the operating system you are running. For more information, see [page 81](#).

- 128 MB (or more) of RAM
- Available compatible PCIe slot (depending on your controller model—see the descriptions starting on [page 17](#))
- 20 MB of free disk drive space
- 16-bit SVGA color monitor with a resolution of at least 800 x 600



- DVD-ROM drive
- Floppy disk drive, USB flash drive, or CD burner, for creating driver disks and bootable media

# About Your RAID Controller

# 3

## In this chapter...

Standard RAID Controller Features .....	18
Adding a Battery Backup Module .....	19
Adding a Flash Backup Module.....	19
About the Adaptec RAID 5085 .....	20
About the Adaptec RAID 5405 .....	21
About the Adaptec RAID 5445 .....	22
About the Adaptec RAID 5805/5805Q.....	23
About the Adaptec RAID 51245 .....	24
About the Adaptec RAID 51645 .....	25
About the Adaptec RAID 52445 .....	26
About the Adaptec RAID 5405Z.....	27
About the Adaptec RAID 5445Z.....	28
About the Adaptec RAID 5805Z/5805ZQ.....	29
About the Adaptec RAID 2045 .....	30
About the Adaptec RAID 2405/2405Q.....	31
About the Adaptec RAID 6405 .....	33
About the Adaptec RAID 6445 .....	34
About the Adaptec RAID 6805/6805Q.....	35
About the Adaptec RAID 6405E.....	36
About the Adaptec RAID 6805E.....	37
About the Adaptec RAID 6405T.....	38
About the Adaptec RAID 6805T/6805TQ.....	39

This chapter provides an overview of the features of your Adaptec RAID controller.

## Standard RAID Controller Features

- Support for SAS disk drives, SATA/SATA II disk drives, and SATA and SAS Solid State Drives (SSDs)
- Flash ROM for updates to controller firmware, BIOS, and the Adaptec RAID Configuration utility
- Disk drive hot-swapping
- Event logging and broadcasting including email and SNMP messages
- Multiple options for creating and managing RAID arrays—A full software application (Adaptec Storage Manager), a BIOS-based utility (ACU), a command line utility (ARCCONF) (see *Managing Your Storage Space* on page 79)
- Native command queuing (NCQ), which lets disk drives arrange commands into the most efficient order for optimum performance
- Support for disk drive enclosures with SES2 enclosure management hardware
- Support for a battery backup module (see page 19)
- Support for a zero maintenance cache protection module (see page 19)
- Support for Adaptec maxCache™ SSD caching (see page 109)  
**Note:** Adaptec maxCache is supported on Adaptec Series Q controllers only.
- Power-management of disk drives in your storage space to reduce cooling and electricity costs (see page 106)
- Audible alarm
- I/O statistics logging

## Array-level Features

**Note:** Not all features are supported by all controllers. For more information, refer to the *Adaptec Storage Manager User's Guide* or online Help.

- Support for RAID 0, RAID 1, RAID 5, RAID 10, RAID 50, simple volumes, and spanned volumes
- Support for hybrid RAID 1 and RAID 10 arrays comprised of hard drives and Solid State Drives (SSDs)
- Support for JBOD disks (appear as a physical disk drives to the operating system; not redundant)
- Support for hot spares (global and dedicated)
- Support for automatic failover, so arrays are automatically rebuilt when a failed drive is replaced (applies to redundant arrays in SES2- or SAF-TE-enabled disk drive enclosures *only*)
- Optimized disk utilization, which ensures that the full capacity of all disk drives can be used, even if the disk drives vary in size
- Online capacity expansion, so you can increase the capacity of an array without recreating it
- Support for array migration from one RAID level to another

## Advanced Data Protection Suite

**Note:** The following features are supported on Adaptec Series 5 and Series 6 controllers. Striped Mirrors are also supported on Series 2 and Series 6E controllers.

- **Copyback Hot Spare**—You can use this feature to move data from a hot spare back to its original location after a failed disk drive is replaced.
- **Striped Mirror (RAID 1E)**—A RAID 1 Enhanced array is similar to a RAID 1 array except that data is both mirrored *and* striped, and more disk drives can be included.
- **Hot Space (RAID 5EE)**—A RAID 5EE array is similar to a RAID 5 array except that it includes a distributed spare and must be built from a minimum of four disk drives.
- **Dual Drive Failure Protection (RAID 6)**—A RAID 6 array is similar to a RAID 5 array except that it includes *two* independent sets of parity data instead of one.
- **Dual Drive Failure Protection (RAID 60)**—A RAID 60 array is similar to a RAID 50 array except that it includes *four* independent sets of parity data instead of two.

## Adding a Battery Backup Module

This table shows the battery model supported by your Adaptec RAID controller. To purchase a battery backup module, refer to the Adaptec Web site at [www.adaptec.com](http://www.adaptec.com).

RAID Controller	Battery Model
Adaptec RAID 5085/Adaptec RAID 5405/Adaptec RAID 5445/Adaptec RAID 5805/5805Q/Adaptec 51245/Adaptec 51645/Adaptec 52445	Adaptec Battery Module 800 Adaptec Battery Module 800T

## Adding a Flash Backup Module

This table shows the flash backup module (“zero maintenance cache protection”) supported by your Adaptec RAID controller. To purchase a flash backup module, refer to the Adaptec Web site at [www.adaptec.com](http://www.adaptec.com).

RAID Controller	Flash Module
Adaptec RAID 5805Z/Adaptec RAID 5805ZQ/Adaptec RAID 5445Z/Adaptec RAID 5405Z	Adaptec Flash Backup Module ZMM-100DB (pre-installed) with ZMM-100CC Supercapacitor Card
Adaptec RAID 6805/Adaptec RAID 6445/Adaptec RAID 6405/Adaptec RAID 6805T/Adaptec RAID 6405T	Adaptec Flash Backup Module AFM-600 (optional) with Supercapacitor Card
Adaptec RAID 6805Q/Adaptec RAID 6805TQ	Adaptec Flash Backup Module AFM-600 (pre-installed) with Supercapacitor Card

## Upgrading the Controller Firmware

To upgrade the firmware on your Adaptec RAID controller, follow the instructions in [Using the Adaptec Flash Utility on page 115](#). You can also use Adaptec Storage Manager or the ARCCONF command-line utility to upgrade your controller firmware. Refer to the *Adaptec Storage Manager User’s Guide* and the *Adaptec Command Line Interface User’s Guide*.

## About the Adaptec RAID 5085

The Adaptec RAID 5085 is a SAS RAID controller with these features:

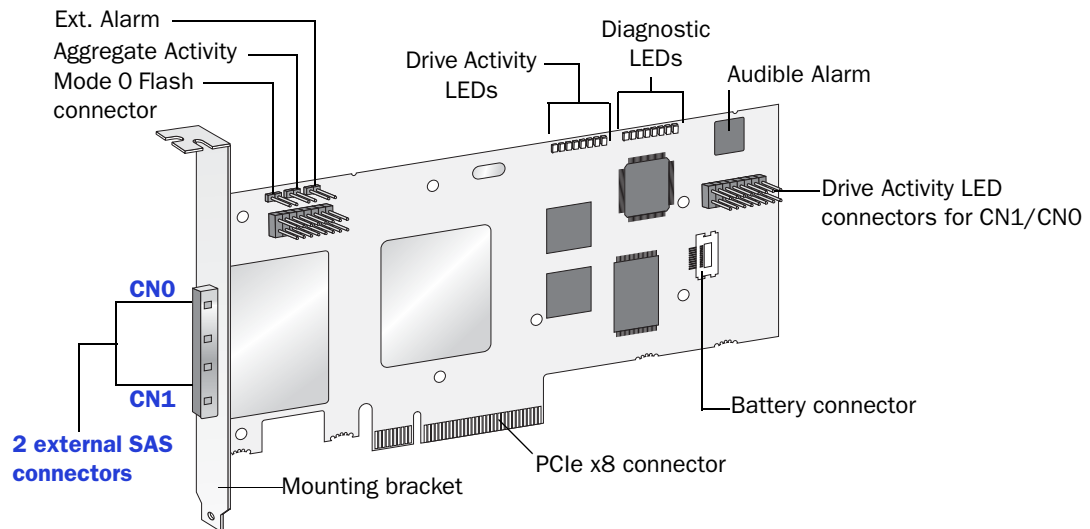



---

Form Factor	Low-profile MD2
Bus compatibility	PCIe 1.1
PCIe bus width	x8
Data transfer rate	3 Gb/s per port
Phys (Unified Serial Ports)	8
Standard cache	512 MB DDR2
Connectors, external	2 mini-SAS x4 (SFF-8088)
Maximum number of disk drives	8 direct-attached (or up to 256 with expanders)
Enclosure Support	I2C and SGPIO (Serial General Purpose Input/Output)
Onboard speaker	Yes
Battery Backup Module	Adaptec Battery Module 800/800T (sold separately—see <a href="#">page 19</a> )

---

## About the Adaptec RAID 5405

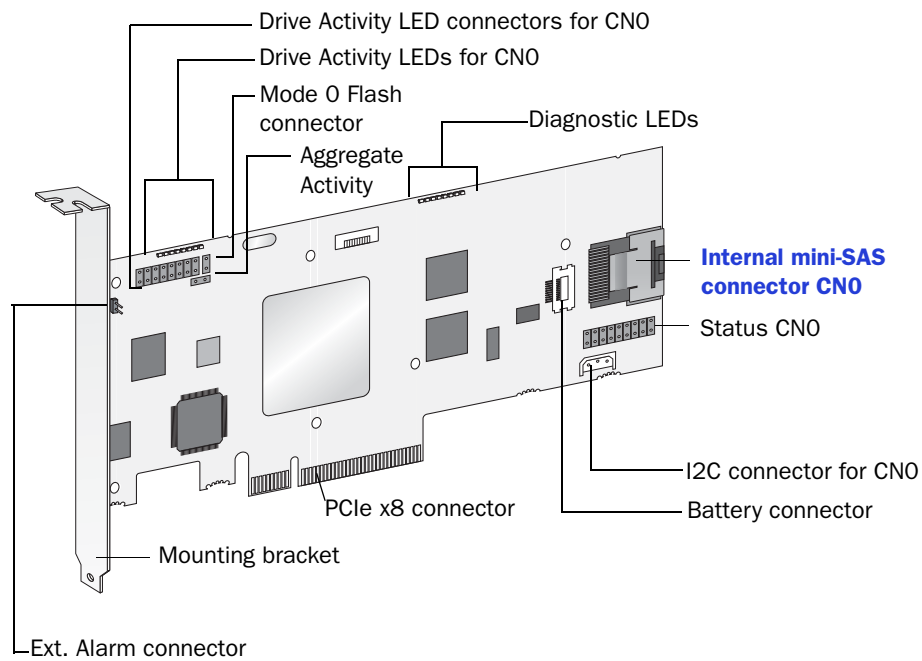
The Adaptec RAID 5405 is a SAS RAID controller with these features:



Form Factor	Low-profile MD2
Bus compatibility	PCIe 1.1
PCIe bus width	x8
Data transfer rate	3 Gb/s per port
Phys (Unified Serial Ports)	4
Standard cache	256 MB DDR2
Connectors, internal	1 mini-SAS x4 (SFF-8087)
Maximum number of disk drives	4 direct-attached (or up to 256 with expanders)
Enclosure Support	I2C and SGPIO (Serial General Purpose Input/Output)
Onboard speaker	Yes
Battery Backup Module	Adaptec Battery Module 800/800T (sold separately—see <a href="#">page 19</a> )

## About the Adaptec RAID 5445

The Adaptec RAID 5445 is a SAS RAID controller with these features:

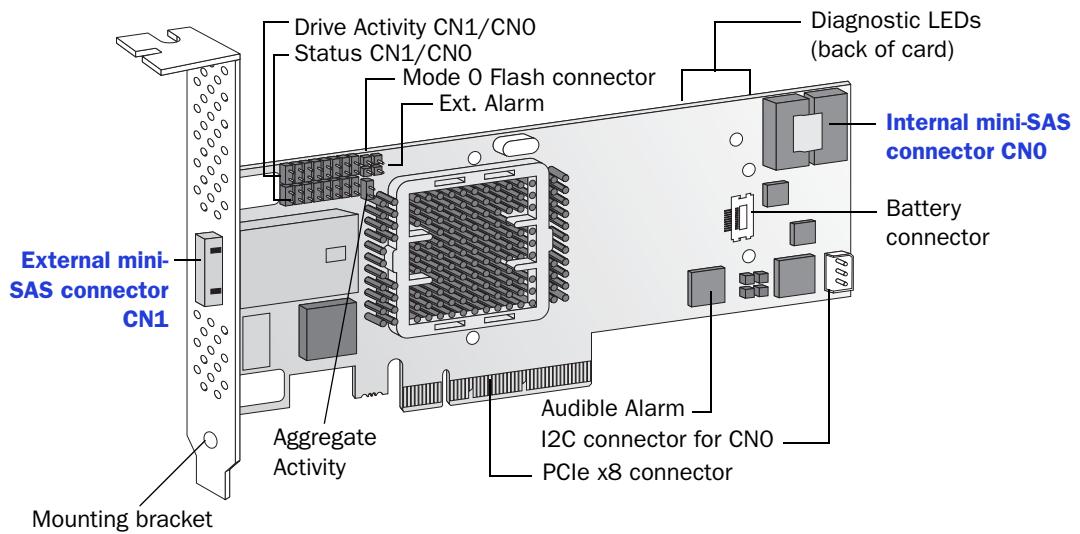

Form Factor	Low-profile MD2
Bus compatibility	PCIe 1.1
PCIe bus width	x8
Data transfer rate	3 Gb/s per port
Phys (Unified Serial Ports)	8
Standard cache	512 MB DDR2
Connectors	1 mini-SAS x4 (SFF-8087) internal 1 mini-SAS x4 (SFF-8088) external
Maximum number of disk drives	8 direct-attached (or up to 256 with expanders)
Enclosure Support	I2C and SGPIO (Serial General Purpose Input/Output)
Onboard speaker	Yes
Battery Backup Module	Adaptec Battery Module 800/800T (sold separately—see <a href="#">page 19</a> )

## About the Adaptec RAID 5805/5805Q

The Adaptec RAID 5805/5805Q is a SAS RAID controller with these features:

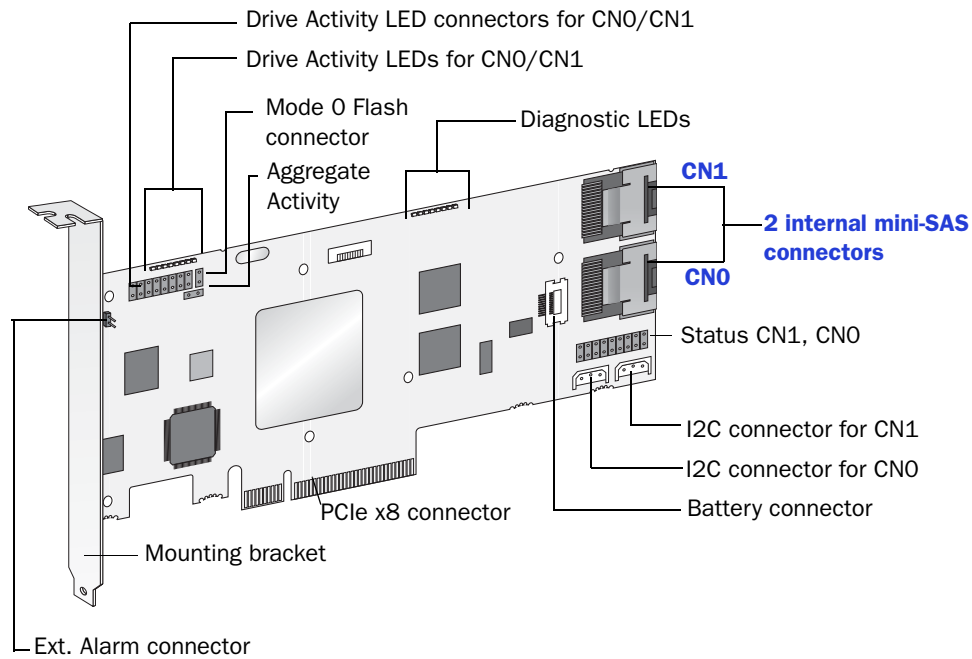

Form Factor	Low-profile MD2
Bus compatibility	PCIe 1.1
PCIe bus width	x8
Data transfer rate	3 Gb/s per port
Phys (Unified Serial Ports)	8
Standard cache	512 MB DDR2
Connectors, internal	2 mini-SAS x4 (SFF-8087)
Maximum number of disk drives	8 direct-attached (or up to 256 with expanders)
maxCache SSD support	<b>5805Q:</b> 8 maxCache-compatible SSDs using any Solid State Drive on compatibility list (2TB max); see <a href="http://www.adaptec.com/compatibility">www.adaptec.com/compatibility</a>
Enclosure Support	I2C and SGPIO (Serial General Purpose Input/Output)
Onboard speaker	Yes
Battery Backup Module	Adaptec Battery Module 800/800T (sold separately—see <a href="#">page 19</a> )



## About the Adaptec RAID 51245

The Adaptec RAID 51245 is a SAS RAID controller with these features:

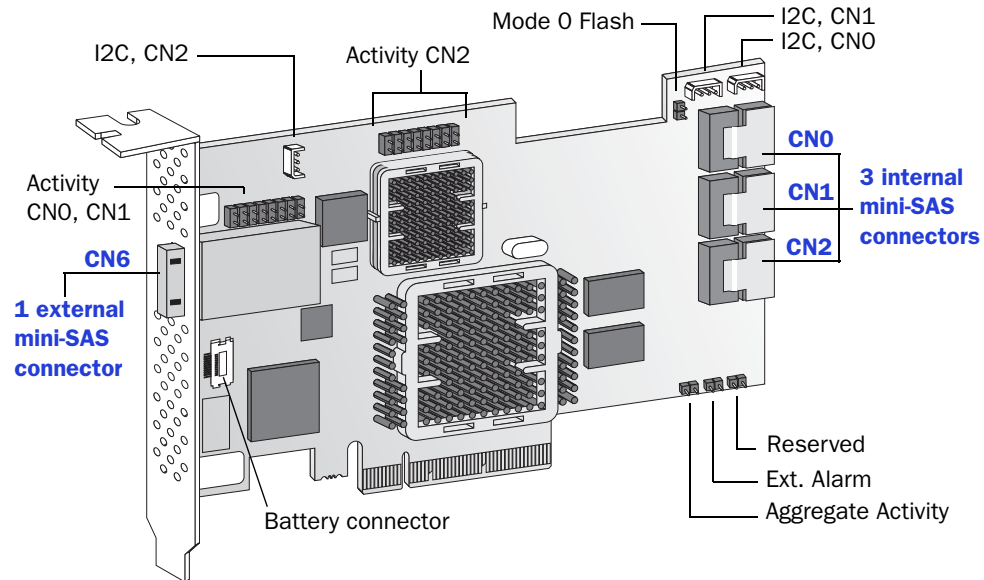

Form Factor	Full Height, Half Length
Bus compatibility	PCIe 1.1
PCIe bus width	x8
Data transfer rate	3 Gb/s per port
Phys (Unified Serial Ports)	16
Standard cache	512 MB DDR2
Connectors, Internal	3 mini-SAS x4 (SFF-8087)
Connectors, External	1 mini-SAS x4 (SFF-8088)
Maximum number of disk drives	16 direct-attached (or up to 256 with expanders)
Enclosure Support	I2C and SGPIO (Serial General Purpose Input/Output)
Onboard speaker	Yes
Battery Backup Module	Adaptec Battery Module 800/800T (sold separately—see <a href="#">page 19</a> )

## About the Adaptec RAID 51645

The Adaptec RAID 51645 is a SAS RAID controller with these features:

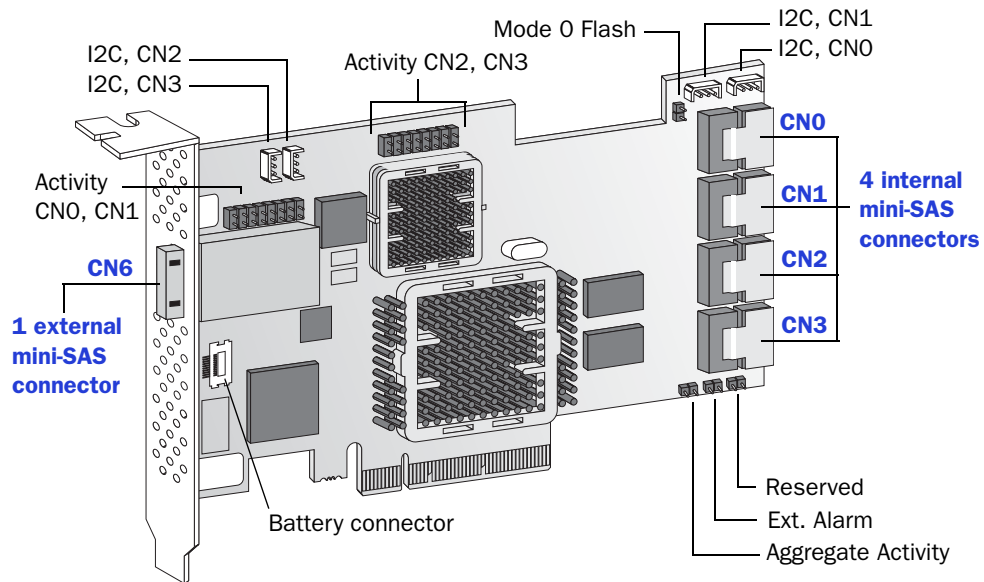

Form Factor	Full Height, Half Length
Bus compatibility	PCIe 1.1
PCIe bus width	x8
Data transfer rate	3 Gb/s per port
Phys (Unified Serial Ports)	20
Standard cache	512 MB DDR2
Connectors, Internal	4 mini-SAS x4 (SFF-8087)
Connectors, External	1 mini-SAS x4 (SFF-8088)
Maximum number of disk drives	20 direct-attached (or up to 256 with expanders)
Enclosure Support	I2C and SGPIO (Serial General Purpose Input/Output)
Onboard speaker	Yes
Battery Backup Module	Adaptec Battery Module 800/800T (sold separately—see <a href="#">page 19</a> )

## About the Adaptec RAID 52445

The Adaptec RAID 52445 is a SAS RAID controller with these features:

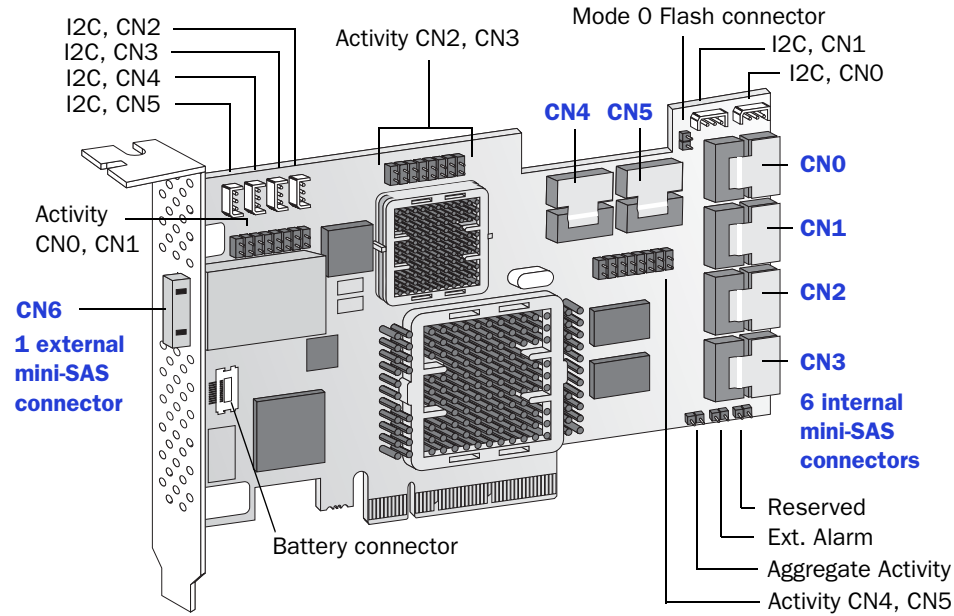

Form Factor	Full Height, Half Length
Bus compatibility	PCIe 1.1
PCIe bus width	x8
Data transfer rate	3 Gb/s per port
Phys (Unified Serial Ports)	28
Standard cache	512 MB DDR2
Connectors, Internal	6 mini-SAS x4 (SFF-8087)
Connectors, External	1 mini-SAS x4 (SFF-8088)
Maximum number of disk drives	28 direct-attached (or up to 256 with expanders)
Enclosure Support	I2C and SGPIO (Serial General Purpose Input/Output)
Onboard speaker	Yes
Battery Backup Module	Adaptec Battery Module 800/800T (sold separately—see <a href="#">page 19</a> )

## About the Adaptec RAID 5405Z

The Adaptec RAID 5405Z is a SAS RAID controller with these features:

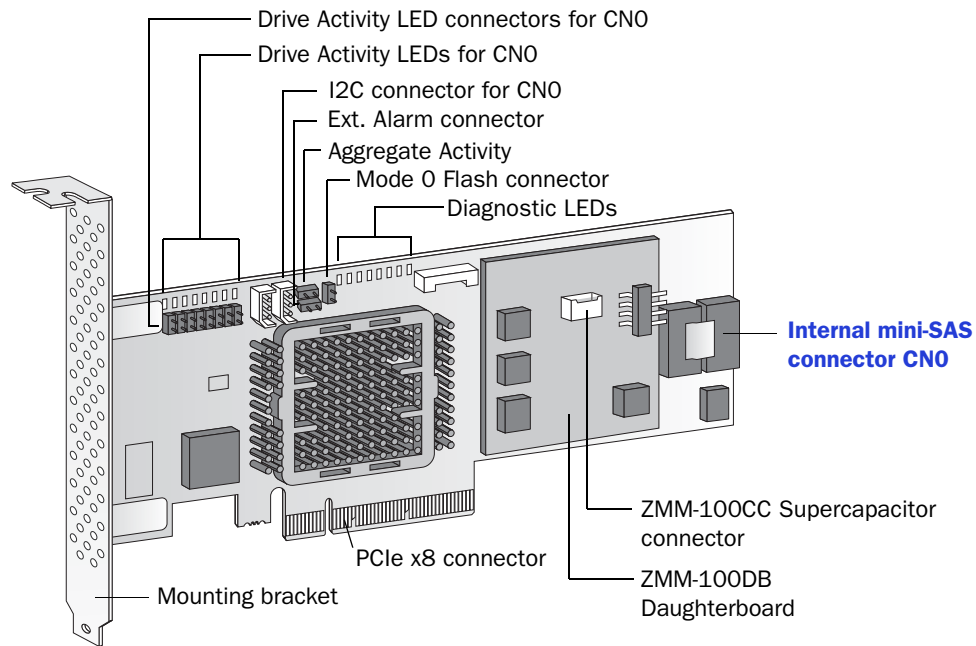

Form Factor	Low-profile MD2
Bus compatibility	PCIe 1.1
PCIe bus width	x8
Data transfer rate	3 Gb/s per port
Phys (Unified Serial Ports)	4
Standard cache	512 MB DDR2
Connectors, internal	1 mini-SAS x4 (SFF-8087)
Maximum number of disk drives	4 direct-attached (or up to 256 with expanders)
Enclosure Support	I2C and SGPIO (Serial General Purpose Input/Output)
Onboard speaker	Yes
Zero Maintenance Cache Protection Module	Adaptec ZMM-100DB daughterboard (pre-installed), Adaptec ZMM-100CC supercapacitor module (user installed—see <a href="#">page 48</a> )

## About the Adaptec RAID 5445Z

The Adaptec RAID 5445Z is a SAS RAID controller with these features:

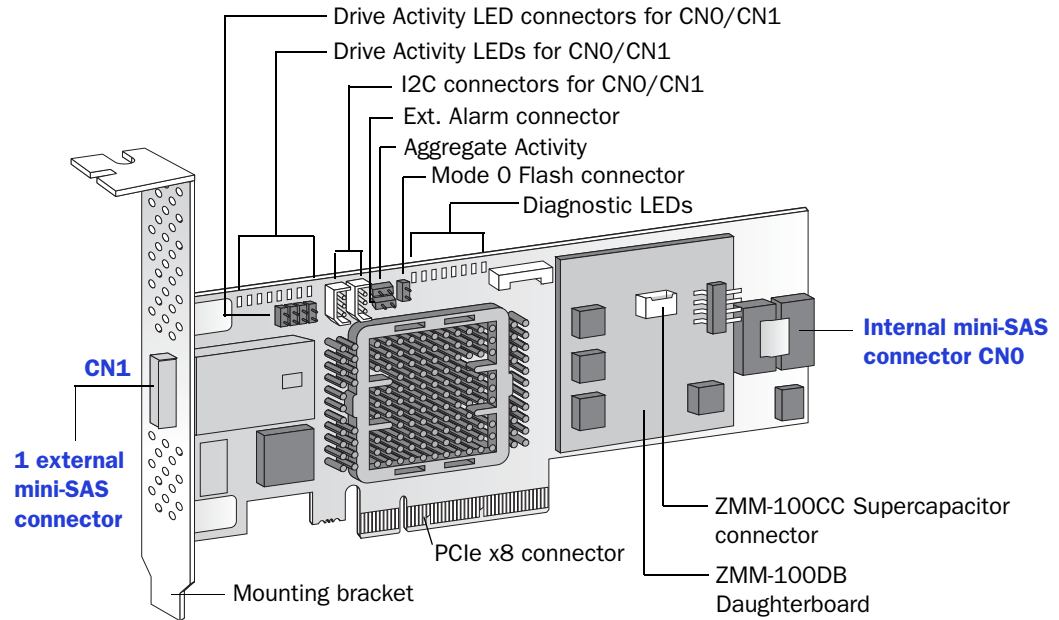

Form Factor	Low-profile MD2
Bus compatibility	PCIe 1.1
PCIe bus width	x8
Data transfer rate	3 Gb/s per port
Phys (Unified Serial Ports)	8
Standard cache	512 MB DDR2
Connectors	1 mini-SAS x4 (SFF-8087) internal 1 mini-SAS x4 (SFF-8088) external
Maximum number of disk drives	8 direct-attached (or up to 256 with expanders)
Enclosure Support	I2C and SGPIO (Serial General Purpose Input/Output)
Onboard speaker	Yes
Zero Maintenance Cache Protection Module	Adaptec ZMM-100DB daughterboard (pre-installed), Adaptec ZMM-100CC supercapacitor module (user installed—see <a href="#">page 48</a> )

## About the Adaptec RAID 5805Z/5805ZQ

The Adaptec RAID 5805Z/5805ZQ is a SAS RAID controller with these features:

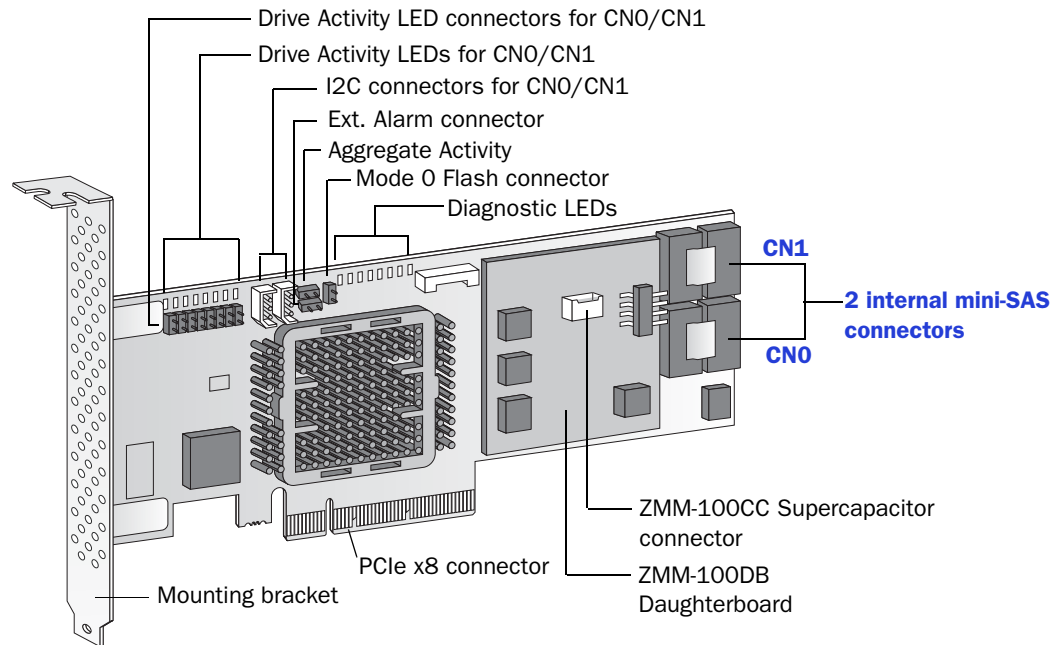

Form Factor	Low-profile MD2
Bus compatibility	PCIe 1.1
PCIe bus width	x8
Data transfer rate	3 Gb/s per port
Phys (Unified Serial Ports)	8
Standard cache	512 MB DDR2
Connectors, internal	2 mini-SAS x4 (SFF-8087)
Maximum number of disk drives	8 direct-attached (or up to 256 with expanders)
maxCache SSD support	<b>5805ZQ:</b> 8 maxCache-compatible SSDs using any Solid State Drive on compatibility list (2TB max); see <a href="http://www.adaptec.com/compatibility">www.adaptec.com/compatibility</a>
Enclosure Support	I2C and SGPIO (Serial General Purpose Input/Output)
Onboard speaker	Yes
Zero Maintenance Cache Protection Module	Adaptec ZMM-100DB daughterboard (pre-installed), Adaptec ZMM-100CC supercapacitor module (user installed—see <a href="#">page 48</a> )

## About the Adaptec RAID 2045

The Adaptec RAID 2045 is a SAS RAID controller with these features:

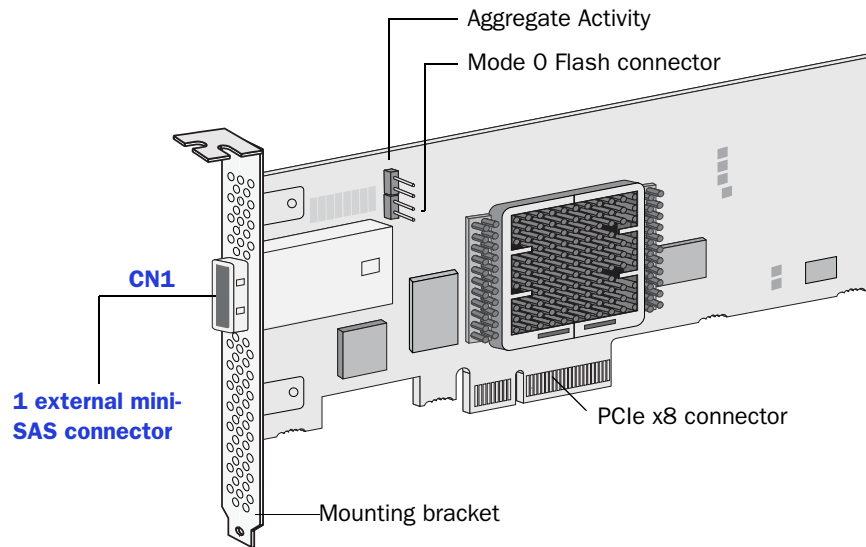



---

Form Factor	Low-profile MD2
Bus compatibility	PCIe 1.1
PCIe bus width	x8
Data transfer rate	3 Gb/s per port
Phys (Unified Serial Ports)	4
Standard cache	128 MB DDR2
Connectors, external	1 mini-SAS x4 (SFF-8088)
Maximum number of disk drives	4 direct-attached (or up to 128 with expanders)
Enclosure Support	I2C and SGPIO (Serial General Purpose Input/Output)
Onboard speaker	No
Battery Backup Module	No

---

## About the Adaptec RAID 2405/2405Q

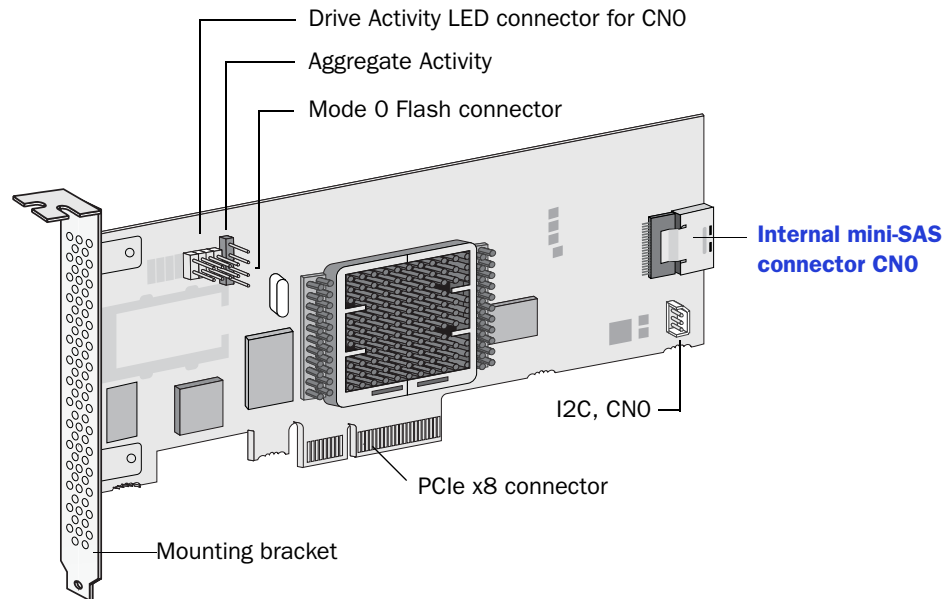
The Adaptec RAID 2405/2405Q is a SAS RAID controller with these features:



Form Factor	Low-profile MD2
Bus compatibility	PCIe 1.1
PCIe bus width	x8
Data transfer rate	3 Gb/s per port
Phys (Unified Serial Ports)	4
Standard cache	128 MB DDR2
Connectors, internal	1 mini-SAS x4 (SFF-8087)
Maximum number of disk drives	4 direct-attached (or up to 128 with expanders)
maxCache SSD support	<b>2405Q:</b> 8 maxCache-compatible SSD using any Solid State Drive on compatibility list (80GB max); see <a href="http://www.adaptec.com/compatibility">www.adaptec.com/compatibility</a>
Enclosure Support	I2C and SGPIO (Serial General Purpose Input/Output)
Onboard speaker	No
Battery Backup Module	No



## About the Adaptec RAID 2805

The Adaptec RAID 2805 is a SAS RAID controller with these features:

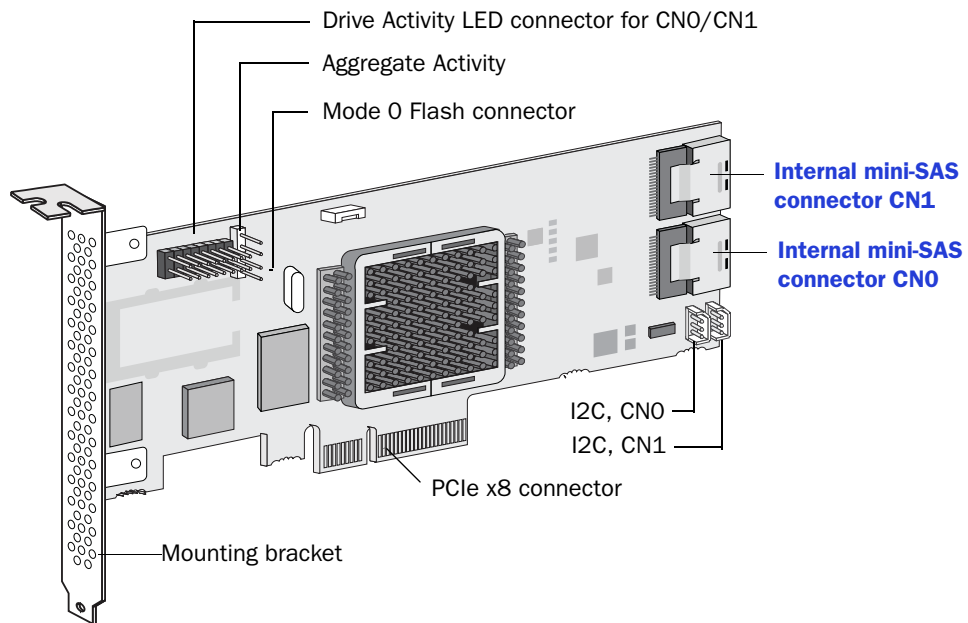

Form Factor	Low-profile MD2
Bus compatibility	PCIe 1.1
PCIe bus width	x8
Data transfer rate	3 Gb/s per port
Phys (Unified Serial Ports)	8
Standard cache	128 MB DDR2
Connectors, internal	2 mini-SAS x4 (SFF-8087)
Maximum number of disk drives	8 direct-attached (or up to 128 with expanders)
Enclosure Support	I2C and SGPIO (Serial General Purpose Input/Output)
Onboard speaker	No
Battery Backup Module	No

## About the Adaptec RAID 6405

The Adaptec RAID 6405 is a SAS RAID controller with these features:

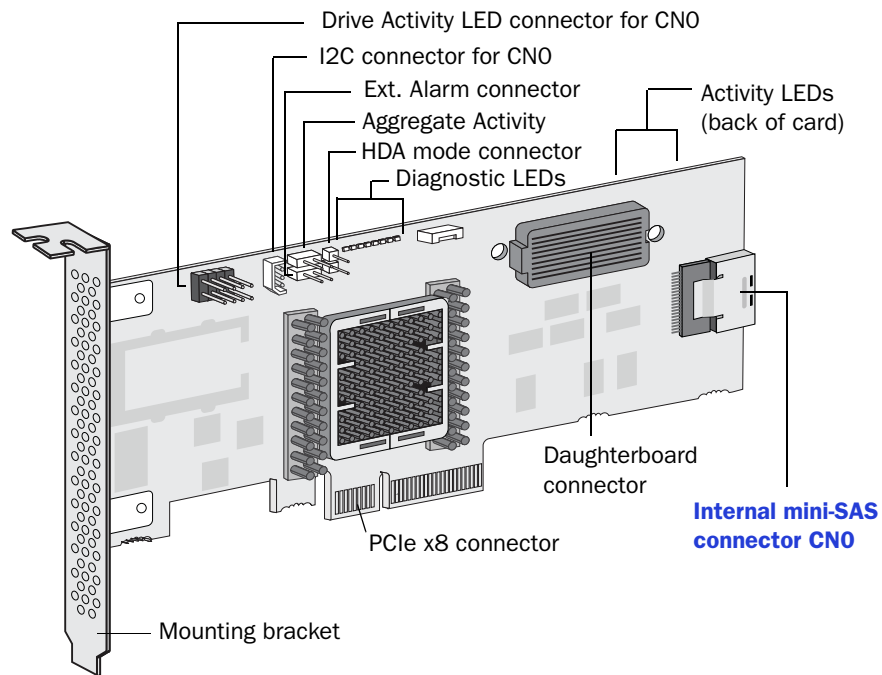

Form Factor	Low-profile MD2
Bus compatibility	PCIe Gen2
PCIe bus width	x8
Data transfer rate	6 Gb/s per port
Phys (Unified Serial Ports)	4
Standard cache	512 MB DDR2
Connectors, internal	1 mini-SAS x4 (SFF-8087)
Maximum number of disk drives	4 direct-attached (or up to 256 with expanders)
Enclosure Support	I2C and SGPIO (Serial General Purpose Input/Output)
Onboard speaker	Yes
Zero Maintenance Cache Protection Module	Adaptec Flash Backup Module AFM-600 (optional; sold separately)

## About the Adaptec RAID 6445

The Adaptec RAID 6445 is a SAS RAID controller with these features:

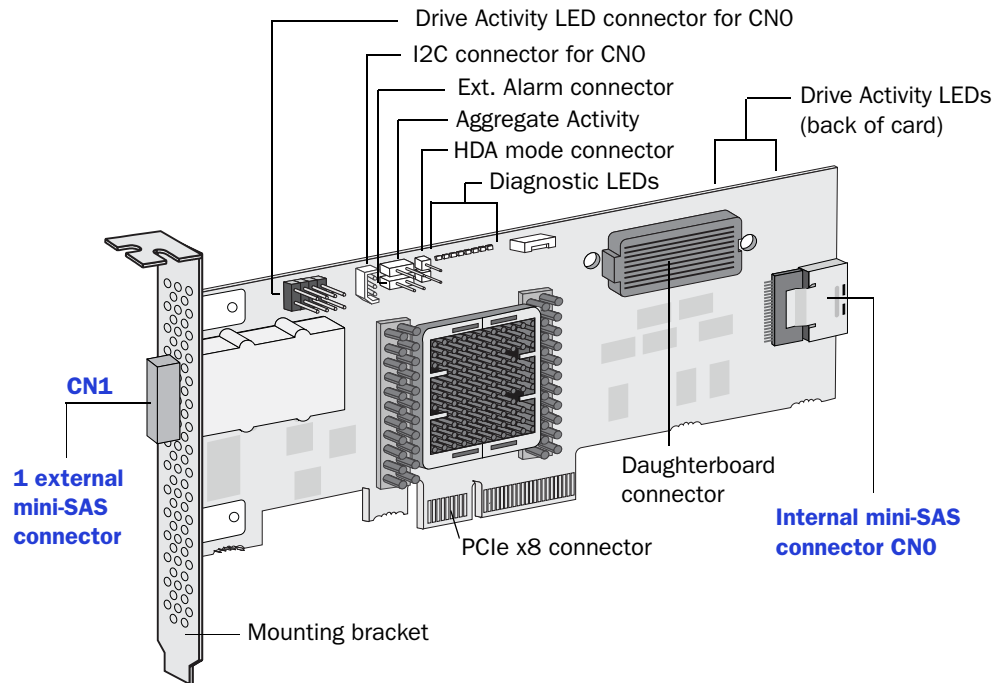

Form Factor	Low-profile MD2
Bus compatibility	PCIe Gen2
PCIe bus width	x8
Data transfer rate	6 Gb/s per port
Phys (Unified Serial Ports)	8
Standard cache	512 MB DDR2
Connectors	1 mini-SAS x4 (SFF-8087) internal 1 mini-SAS x4 (SFF-8088) external
Maximum number of disk drives	8 direct-attached (or up to 256 with expanders)
Enclosure Support	SES, I2C, and SGPIO (Serial General Purpose Input/Output)
Onboard speaker	Yes
Zero Maintenance Cache Protection Module	Adaptec Flash Backup Module AFM-600 (optional; sold separately)

## About the Adaptec RAID 6805/6805Q

The Adaptec RAID 6805/6805Q is a SAS RAID controller with these features:

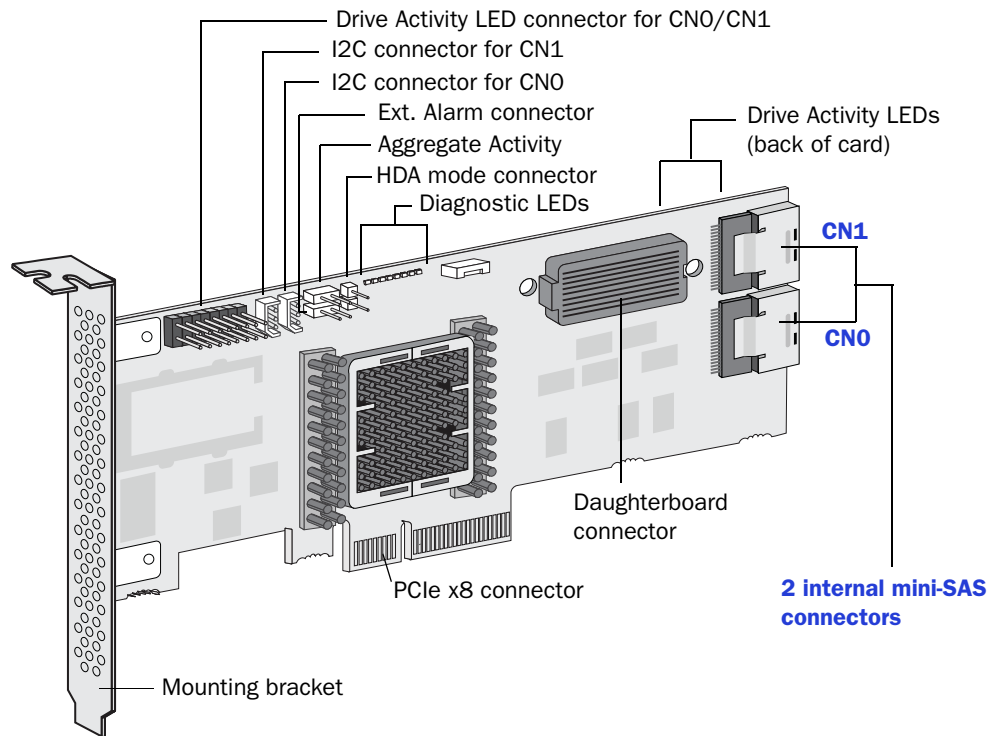

Form Factor	Low-profile MD2
Bus compatibility	PCIe Gen2
PCIe bus width	x8
Data transfer rate	6 Gb/s per port
Phys (Unified Serial Ports)	8
Standard cache	512 MB DDR2
Connectors, internal	2 mini-SAS x4 (SFF-8087)
Maximum number of disk drives	8 direct-attached (or up to 256 with expanders)
maxCache SSD support	<b>6805Q:</b> Up to eight solid state drives, 1TB capacity, max. See the maxCache compatibility list at <a href="http://www.adaptec.com/compatibility">www.adaptec.com/compatibility</a> .
Enclosure Support	I2C and SGPIO (Serial General Purpose Input/Output)
Onboard speaker	Yes
Zero Maintenance Cache Protection Module	Adaptec Flash Backup Module AFM-600 (6805: optional, sold separately; 6805Q: standard, pre-installed)

## About the Adaptec RAID 6405E

The Adaptec RAID 6405E is a SAS RAID controller with these features:

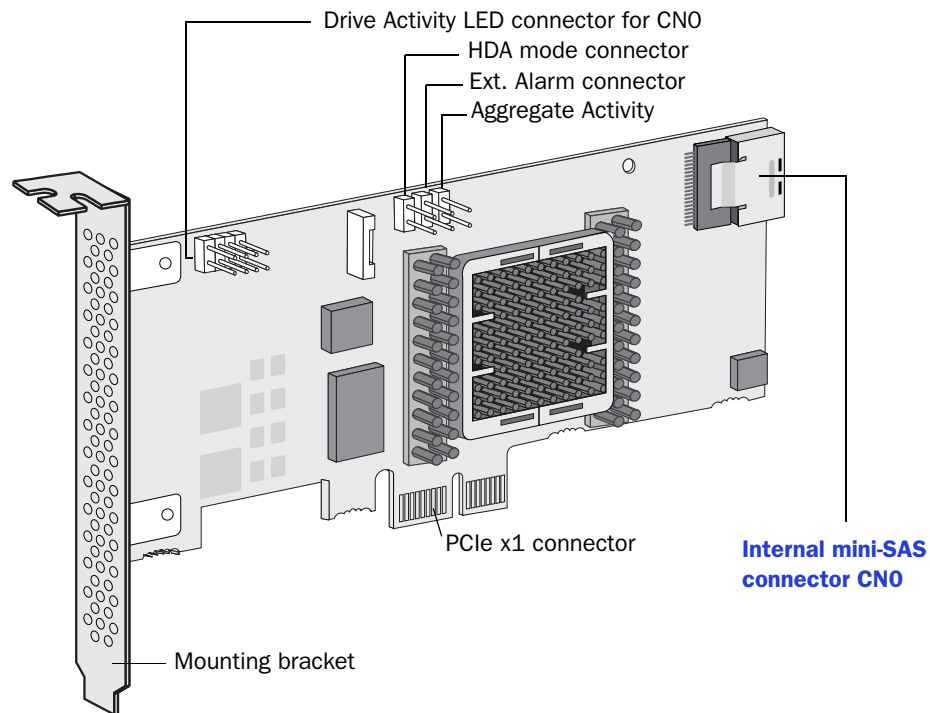



---

Form Factor	Low-profile MD2 (reduced length: 5.12 inches)
Bus compatibility	PCIe Gen2
PCIe bus width	x1
Data transfer rate	6 Gb/s per port
Phys (Unified Serial Ports)	4
Standard cache	128 MB DDR2
Connectors, internal	1 mini-SAS x4 (SFF-8087)
Maximum number of disk drives	4 direct-attached
Enclosure Support	SGPIO (Serial General Purpose Input/Output)
Onboard speaker	Yes
Battery Backup Module	No

---

## About the Adaptec RAID 6805E

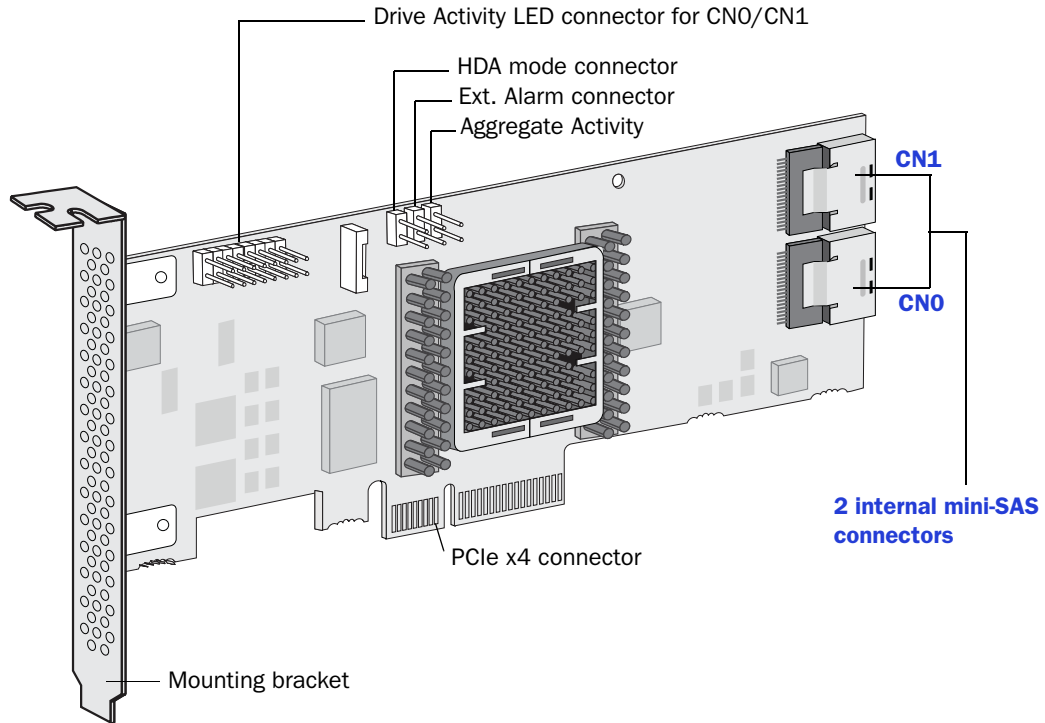
The Adaptec RAID 6805E is a SAS RAID controller with these features:



Form Factor	Low-profile MD2 (reduced length: 6.1 inches)
Bus compatibility	PCIe Gen2
PCIe bus width	x4
Data transfer rate	6 Gb/s per port
Phys (Unified Serial Ports)	8
Standard cache	128 MB DDR2
Connectors, internal	2 mini-SAS x4 (SFF-8087)
Maximum number of disk drives	8 direct-attached
Enclosure Support	SGPIO (Serial General Purpose Input/Output)
Onboard speaker	Yes
Battery Backup Module	No

## About the Adaptec RAID 6405T

The Adaptec RAID 6405T is a SAS RAID controller with these features:

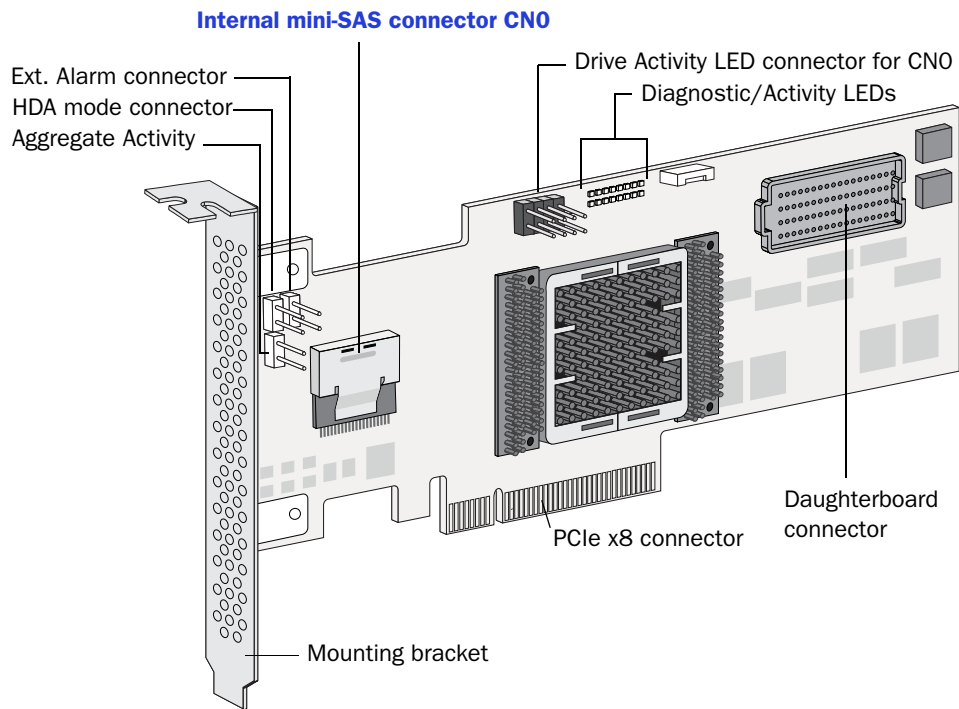

Form Factor	Low-profile MD2
Bus compatibility	PCIe Gen2
PCIe bus width	x8
Data transfer rate	6 Gb/s per port
Phys (Unified Serial Ports)	4
Standard cache	512 MB DDR2
Connectors, internal	1 mini-SAS x4 (SFF-8087)
Maximum number of disk drives	4 direct-attached (or up to 256 with expanders)
Enclosure Support	SGPIO (Serial General Purpose Input/Output)
Onboard speaker	Yes
Zero Maintenance Cache Protection Module	Adaptec Flash Backup Module AFM-600 (optional; sold separately)

## About the Adaptec RAID 6805T/6805TQ

The Adaptec RAID 6805T/6805TQ is a SAS RAID controller with these features:

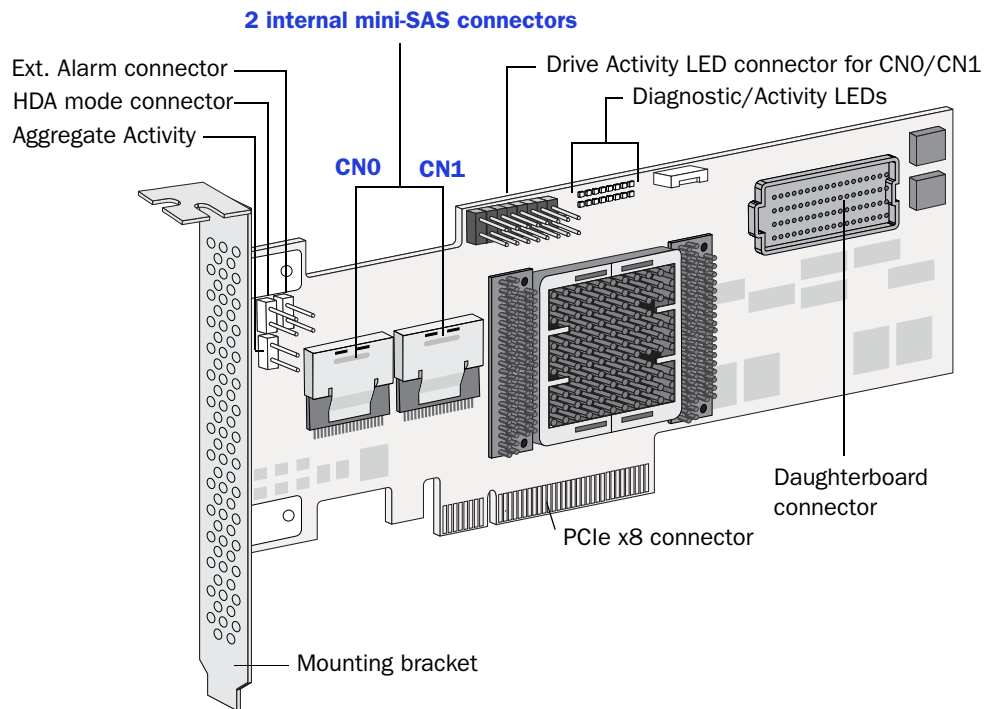

Form Factor	Low-profile MD2
Bus compatibility	PCIe Gen2
PCIe bus width	x8
Data transfer rate	6 Gb/s per port
Phys (Unified Serial Ports)	8
Standard cache	512 MB DDR2
Connectors, internal	2 mini-SAS x4 (SFF-8087)
Maximum number of disk drives	8 direct-attached (or up to 256 with expanders)
maxCache SSD support	<b>6805TQ</b> : Up to eight solid state drives, 1TB capacity, max. See the maxCache compatibility list at <a href="http://www.adaptec.com/compatibility">www.adaptec.com/compatibility</a> .
Enclosure Support	SGPIO (Serial General Purpose Input/Output)
Onboard speaker	Yes
Zero Maintenance Cache Protection Module	Adaptec Flash Backup Module AFM-600 (6805T: optional, sold separately; 6805TQ: standard, pre-installed)



# Getting Started

# 4

## In this chapter...

Choosing a RAID Level.....	41
Selecting Disk Drives and Cables .....	42
Replacing the Full-Height Bracket with a Low-Profile Bracket .....	43
Installation Options .....	45
Basic Installation Steps.....	45

This chapter provides the basic information you need to set up your disk drives and arrays the way you want them. It describes the options you have for installing your Adaptec RAID controller and disk drives and creating arrays for storage. It also describes how to prepare your controller for installation into a low-profile computer cabinet.

## Choosing a RAID Level

This section provides a brief overview of the RAID levels supported by your Adaptec RAID controller, including the minimum and maximum number of disk drives required by each.

**Note:** Before you begin, familiarize yourself with your controller's physical features and the RAID levels that it supports (see [Standard RAID Controller Features on page 18](#)).

- **RAID 0 (Non-redundant Array)**—Stripes data across multiple disk drives. Improved performance but no redundancy (see [page 96](#)).
- **RAID 1 Array**—Created from two disk drives where one disk drive is a *mirror* of the other (the same data is stored on each disk drive). Redundancy, but reduced capacity (see [page 97](#)).
- **RAID 1E Array**—Similar to a RAID 1 array except that data is mirrored *and* striped, and more disk drives can be included (see [page 97](#)).
- **RAID 5 Array**—Stripes data for improved performance and uses *parity* data to provide redundancy (see [page 99](#)).
- **RAID 5EE Array**—Similar to a RAID 5 array, but includes a distributed spare and must include a minimum of four disk drives (see [page 100](#)).
- **RAID 10 Array**—Built from two or more equal-sized RAID 1 arrays, stripes and mirrors data across multiple disk drives. Redundancy and improved performance (see [page 98](#)).
- **RAID 50 Array**—Built from multiple disk drives configured as two or more RAID 5 arrays, stripes stored data and parity data across all disk drives (see [page 101](#)).
- **RAID 6 Array**—Similar to a RAID 5 array except that it includes *two* independent sets of parity data instead of one (see [page 102](#)).
- **RAID 60 Array**—Similar to a RAID 50 array except that it includes *four* independent sets of parity data instead of two (see [page 102](#)).

Use the table on [page 103](#) to see how many disk drives you must connect to your RAID controller to support the RAID level you want.

## Selecting Disk Drives and Cables

### Disk Drives

Your SAS controller supports SAS disk drives, SATA disk drives, and SATA and SAS Solid State Drives (SSDs). When selecting disk drives for your RAID array, ensure that all the disk drives have the same performance level. You can use different-sized disk drives in the array, but the array will be limited to the capacity of the smallest and slowest disk drive. For more information about arrays, refer to the *Adaptec Storage Manager User's Guide* or online Help. For more information about compatible disk drives, refer to the Adaptec Web site at [www.adaptec.com/compatibility](http://www.adaptec.com/compatibility).

### Cables

Depending on your requirements, you can use any of these cables:

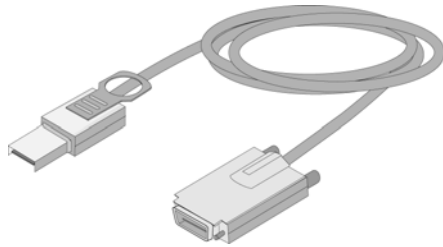

External mini-SAS (SFF-8088 to SFF-8470)—  
Connects to an external SAS enclosure.

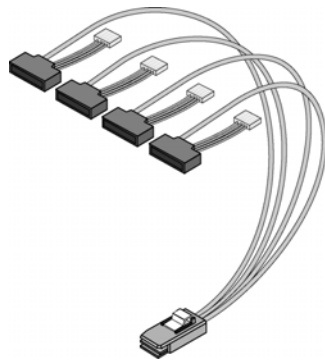

Internal mini-SAS with power (SFF-8087 to SFF-8482)—Connects  
to four SAS or SATA disk drives.

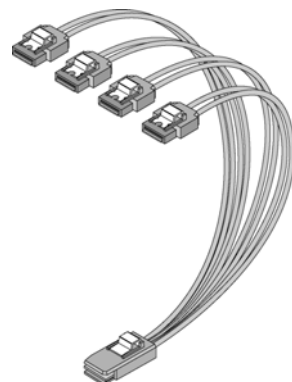

Internal mini-SAS to SATA fan-out (SFF-8087 to 4x SATA)—Connects  
to four SATA disk drives.

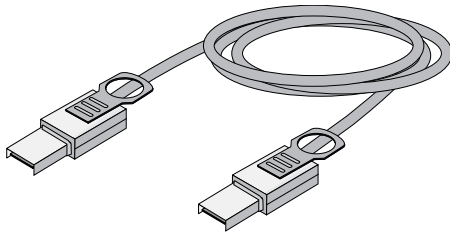

External mini-SAS to mini-SAS (SFF-8088 to SFF-8088)—  
Connects to a backplane or enclosure.



Internal mini-SAS to mini-SAS (SFF-8087 to SFF-8087)—  
Connects to a backplane or enclosure.

Cable connectors are keyed so that you can't insert them incorrectly.

We recommend using only Adaptec SAS cables. For more information or to purchase cables, visit the Adaptec Web site at [www.adaptec.com](http://www.adaptec.com).

## Replacing the Full-Height Bracket with a Low-Profile Bracket

If you are installing your Adaptec RAID controller into a low-profile computer cabinet, replace the original full-height bracket with the low-profile bracket included in your distribution kit. The full-height bracket is mounted on the *front* of the controller, the low-profile bracket is mounted on the *back* of the controller, as shown in the figure below.

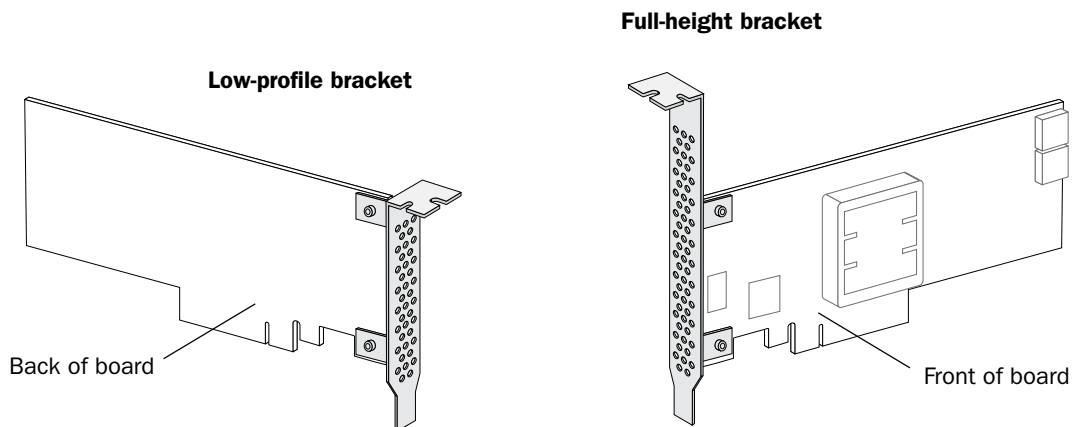

To replace the full-height bracket with the low-profile bracket:

- 1 Remove the full-height bracket from the controller board. The full-height bracket is installed on the front side of the controller, with the mounting screws inserted from the back of the controller, as shown in the Figure 1. Using a Phillips head screw driver, remove the mounting screws, as shown in Figure 2, then set the screws aside for use in [Step 2](#).

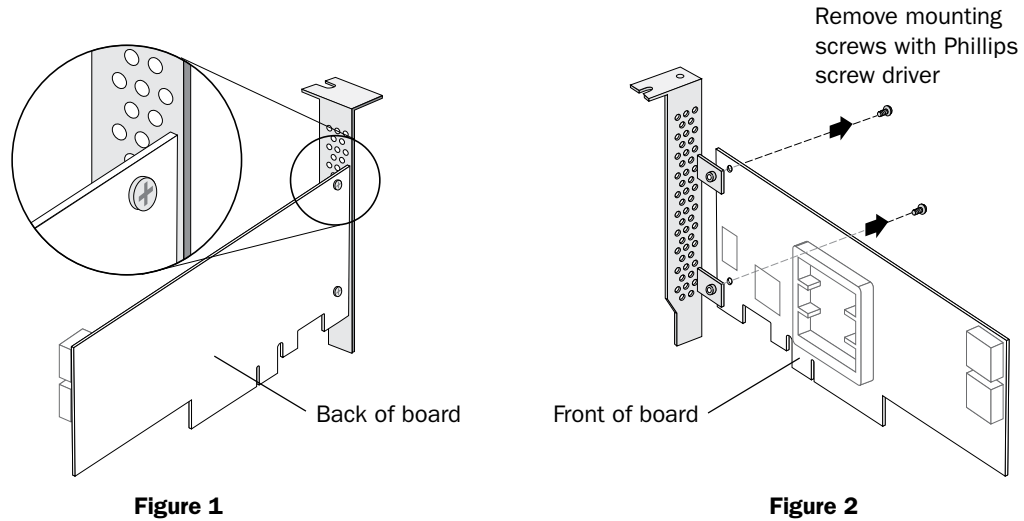

- 2 Attach the low-profile bracket to the controller board. The low-profile bracket is installed on the *back* side of the controller, with the mounting screws inserted from the front of the controller, as shown the Figure 3.

Insert the screws through the holes on the front of the controller, then fasten the screws to the bracket with a Phillips screw driver.

**⚠ Caution:** The mount points on the low-profile bracket have a smooth or flat side and a raised side that looks like a spacer (see Figure 3). Be sure to install the bracket with the flat side against the controller PCB and the raised side facing away from the PCB.

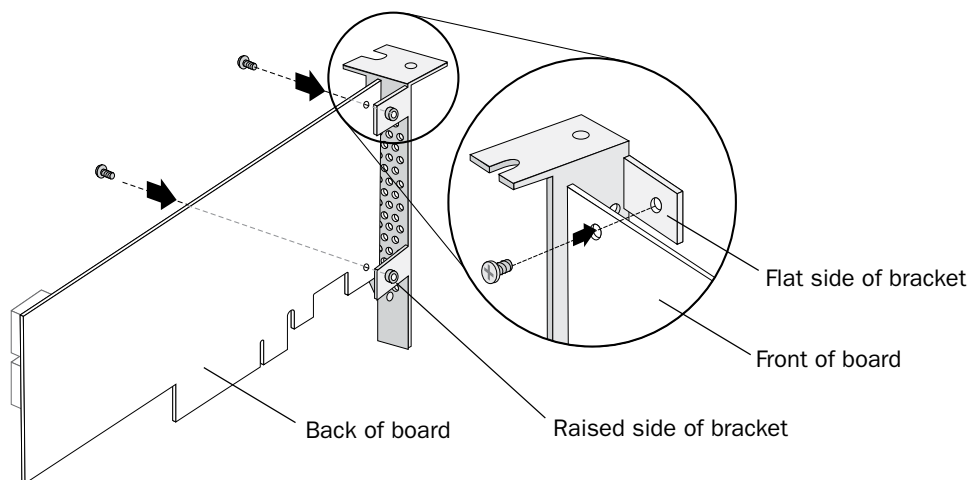

Figure 3

**⚠ Caution:** The torque on the mounting screws should be a maximum of 3.0-4.0 lbf-in to avoid deformation. Be sure that the controller is not bent after attaching the low-profile bracket to the controller board.

## Installation Options

When you install your Adaptec RAID controller, you can choose to create a bootable array and then install your operating system and the controller driver on that array.

Alternatively, you can complete a standard installation, where the controller driver is installed on an existing operating system.

## Basic Installation Steps

This section describes the installation process. Follow the steps for the installation option you've chosen.

### Installing with an Operating System

- 1 Install and connect your controller and internal disk drives (see [page 46](#)).  
If your controller has an external connector, you can connect external disk drives as well (or instead).
- 2 Set the boot controller (see [page 55](#)).
- 3 Create a bootable array (see [page 55](#)).
- 4 Install your operating system and the controller driver (see [page 59](#).)
- 5 Install Adaptec Storage Manager and begin to manage your data storage (see [page 79](#)).

### Installing on an Existing Operating System

- 1 Install and connect your controller and internal disk drives (see [page 46](#)).  
If your controller has an external connector, you can connect external disk drives as well (or instead).
  - 2 Install the controller driver (see [page 72](#)).
  - 3 Install Adaptec Storage Manager and begin to manage your data storage (see [page 79](#)).
-

# Installing the Controller and Disk Drives

# 5

**In this chapter...**

- Before You Begin ..... 47
- Installing the Controller..... 47
- Connecting Disk Drives to Your Controllers..... 50
- Connecting External Devices..... 53
- Next Steps ..... 53

This chapter explains how to install your Adaptec RAID controller, and how to install and connect internal and external disk drives.

## Before You Begin

- Read *Safety Information* on page 147.
- Familiarize yourself with your RAID controller's physical features and the RAID levels that it supports (see page 18).
- Ensure you have the right quantity of disk drives for the RAID level you want to use for your arrays (see page 42).
- Ensure that you have the proper cables for your controller and disk drives (see page 42).
- If you are installing a low-profile RAID controller into a low-profile computer cabinet, replace the original full-height bracket with the low-profile bracket included in the kit (see page 43).

## Installing the Controller

This section describes how to install your Adaptec RAID controller into your computer cabinet. Adaptec RAID controllers come in two basic configurations: Standard and Zero Maintenance Cache Protection with batteryless backup (ZMCP). ZMCP uses flash memory and a supercapacitor module to protect the cache without a battery.

Follow one of these sets of instructions:

- To install a standard series Adaptec RAID controller (without Zero Maintenance Cache Protection), see the following section.
- To install an Adaptec RAID controller with Zero Maintenance Cache Protection, see page 48.

**⚠ Caution:** Be sure to handle the controller by its bracket or edges only.

### Installing a RAID Controller

- 1 Turn off your computer and disconnect the power cord. Open the cabinet, following the manufacturer's instructions.
- 2 Select an available PCIe expansion slot that's compatible with your RAID controller and remove the slot cover, as shown at right. (PCIe bus compatibility is marked to the controller figures in *About Your RAID Controller* on page 17.)

**⚠ Caution:** Touch a grounded metal object before handling the RAID controller.

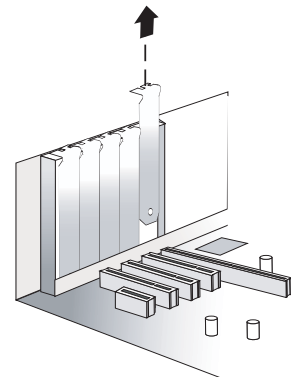



- 3 As shown at right, insert the RAID controller into the expansion slot and press down gently but firmly until it clicks into place. When installed properly, the RAID controller should appear level with the expansion slot.
- 4 Secure the bracket in the expansion slot, using the retention device (for instance, a screw or lever) supplied with your computer.
- 5 Connect your computer's disk activity LED cable to the LED connector on the controller (marked on the figures in [About Your RAID Controller on page 17](#)).

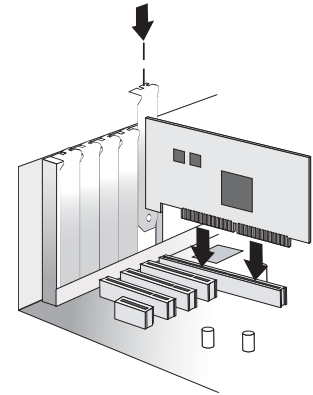

Ensure that the positive lead of the LED cable (usually a red wire or a wire marked with a red stripe) is attached to pin 1.

- 6 **Optional**—Connect your RAID controller's I2C connector (not available on all models) to an I2C connector on an internal backplane or enclosure, using an I2C cable. For more connection details, see [About Your RAID Controller on page 17](#).
- 7 Prepare and install your internal disk drives, following the instructions in [Connecting Disk Drives to Your Controllers on page 50](#).

If you are not installing internal disk drives, close your computer cabinet, reattach the power cord, then continue with [Connecting External Devices on page 53](#).

## Installing a RAID Controller with Zero Maintenance Cache Protection

**Note:** On Adaptec Series 5Z and Series 6Q controllers, the flash module daughterboard is pre-installed. On Adaptec controllers with *optional* Zero Maintenance Cache Protection (see [page 19](#)), the daughterboard is user installed. The supercapacitor module (used by all controllers with Zero Maintenance Cache Protection) is never pre-installed. Refer to the flyer included in the kit for details about installing the flash module daughterboard on the controller, as needed.

- Warning:** (i) Do NOT remove or insert a fully charged supercapacitor module. Always discharge the unit first to avoid damage to the controller or flash backup module. The factory ships with discharged units, so they are safe to install when you receive them. To ensure that an installed unit is discharged, switch your system OFF, then wait 5 minutes. After a dirty shutdown, wait 3 minutes after backup is complete, then remove the unit. (ii) Do not attempt to connect a Battery Backup Module (see [page 19](#)) to an Adaptec RAID controller with Zero Maintenance Cache Protection. The battery can overheat and may even explode!

- 1 Turn off your computer and disconnect the power cord. Open the cabinet, following the manufacturer's instructions.
- 2 Select an available PCIe expansion slot that's compatible with your RAID controller and remove the slot cover, as shown at right. (PCIe bus compatibility is marked to the controller figures in [About Your RAID Controller on page 17](#).)

**Caution:** Touch a grounded metal object before handling the RAID controller.

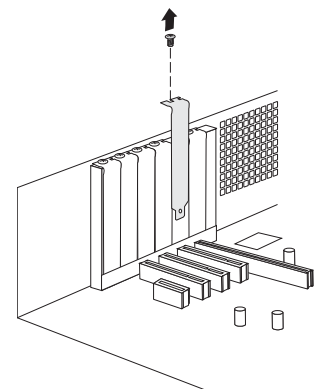

- 3 As shown at right, insert the RAID controller into the expansion slot and press down gently but firmly until it clicks into place. When installed properly, the RAID controller should appear level with the expansion slot.
- 4 Secure the bracket in the expansion slot, using the retention device (for instance, a screw or lever) supplied with your computer.

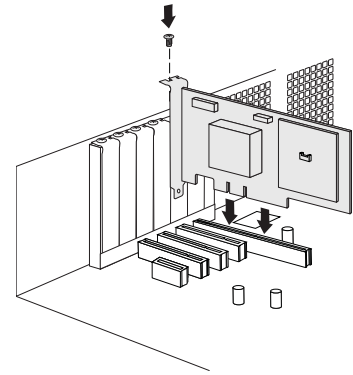

- 5 Attach the supercapacitor module to the RAID controller by inserting the connector into the socket on the flash module daughterboard, as shown at right. The connector attaches to the socket in only one direction.
- 6 Choose a location on the chassis or in the system to fix the tethered supercapacitor module using the included cable-ties such that (i) the cable (18.5") reaches the mating location on the RAID controller when the controller is installed in the expansion slot; (ii) wiring is routed and secured so that it does not contact any moving parts (fans, for instance); and (iii) the supercapacitor module is protected from heat.

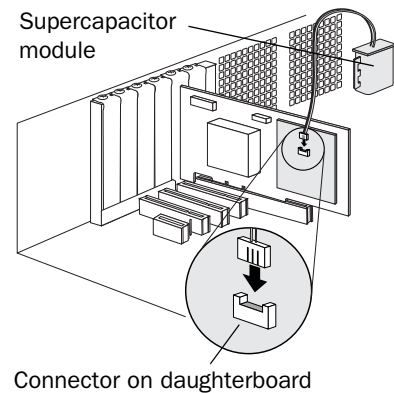

- 7 Thread the cable-ties through the slots on the supercapacitor module and fix to the selected location on the computer chassis. The cable-ties should completely encircle the supercapacitor module to ensure that it is held in place securely, as shown in the figure at right. Be careful not to restrict air-flow through your system.

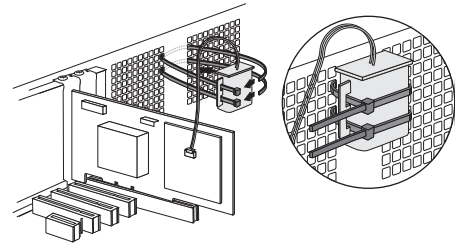

- 8 Connect your computer's disk activity LED cable to the LED connector on the controller (marked on the figures in [About Your RAID Controller on page 17](#)).

Ensure that the positive lead of the LED cable (usually a red wire or a wire marked with a red stripe) is attached to pin 1.

- 9 Connect your RAID controller's I2C connector to an I2C connector on an internal backplane or enclosure, using an I2C cable. For more connection details, see [About Your RAID Controller on page 17](#).
- 10 Prepare and install your internal disk drives, following the instructions in [Connecting Disk Drives to Your Controllers on page 50](#).

If you are not installing internal disk drives, close your computer cabinet, reattach the power cord, then continue with [Connecting External Devices on page 53](#).

## Connecting Disk Drives to Your Controllers

You can connect SAS disk drives, SATA disk drives, and SATA and SAS Solid State Drives (SSDs) to your Adaptec RAID controller. (See [www.adaptec.com/compatibility](http://www.adaptec.com/compatibility) for a list of compatible drives.) There are no jumpers or switches to set before installation.

If you plan to build a bootable array, ensure you install at least the minimum number disk drives required to support the RAID level you want. See [page 41](#) for more information.

**Note:** Although you can connect both SAS and SATA disk drives to your SAS controller, we recommend that you *not* combine SAS and SATA disk drives within the same array or logical drive. See [page 89](#) for more information.

You have two connection options:

- To connect directly to the controller, see the following section.
- To connect to a backplane, see [page 51](#).

To connect Solid State Drives to your controller, see [page 52](#).

### Connecting Drives Directly to the Controller

In a direct-attach connection, SAS or SATA disk drives are connected directly to a SAS card with SAS cables. The number of direct-attached disk drives is limited to four per internal SAS connector. (For more information about direct-attach connections, see [page 92](#).)

- 1 Install your internal SAS or SATA disk drives, following the instructions in your system's documentation.
- 2 Use internal SAS or mini-SAS cables to attach the disk drives to the controller, as shown in the following example.

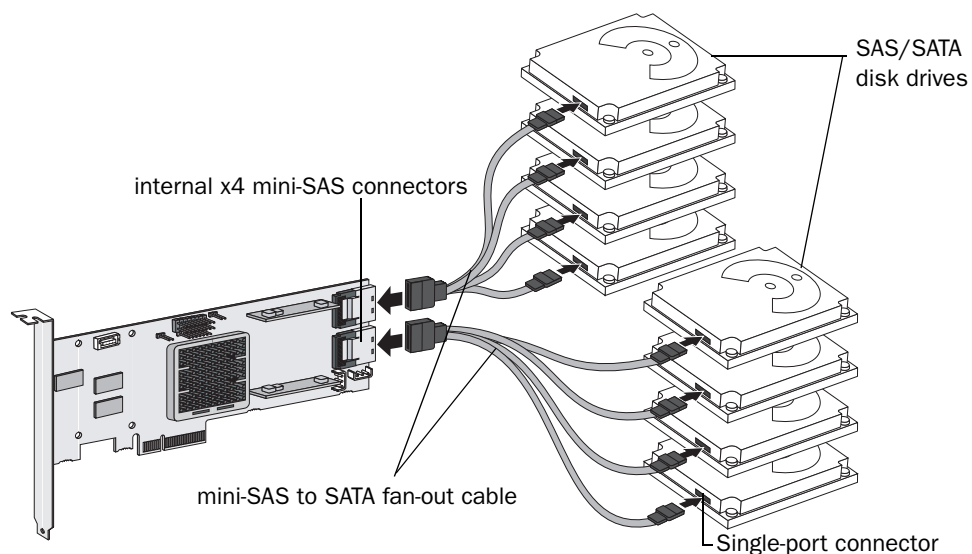

**Note:** SAS fan-out cables are also available with an additional sideband (SFF-8448) cable that carries SGPIO signals for enclosure management. This additional sideband cable is not used with direct-attached disk drives.

- 3 When all internal disk drives have been installed and attached to the controller, close your computer cabinet, reattach the power cord, then continue with [Connecting External Devices on page 53](#).

## Connecting Drives to a System Backplane

In a backplane connection, disk drives and SAS cards are attached to and communicate with each other through a system backplane.

The number of disk drives is limited to the number of slots available on the backplane. Some backplanes have embedded SAS expanders and can support up to 128 end devices. (For more information about backplane and expander connections, see [page 92](#).)

- 1 Connect one or more internal SAS or SATA disk drives to the backplane. (Refer to your system's documentation for more information.)
- 2 Use an internal SAS cable to connect the controller to the backplane, as shown in the examples on [page 51](#).

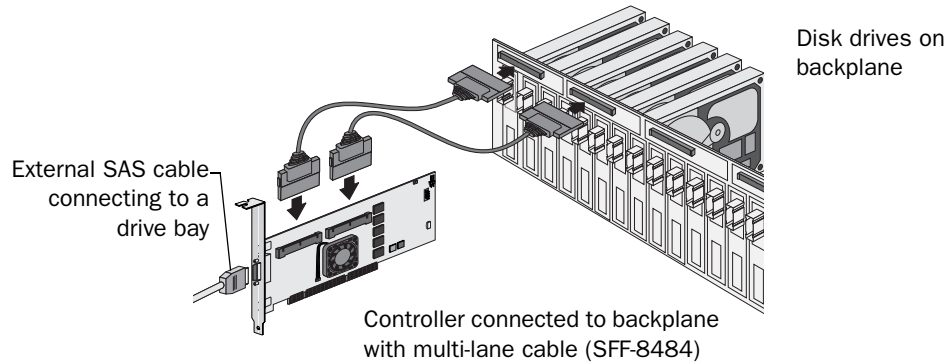
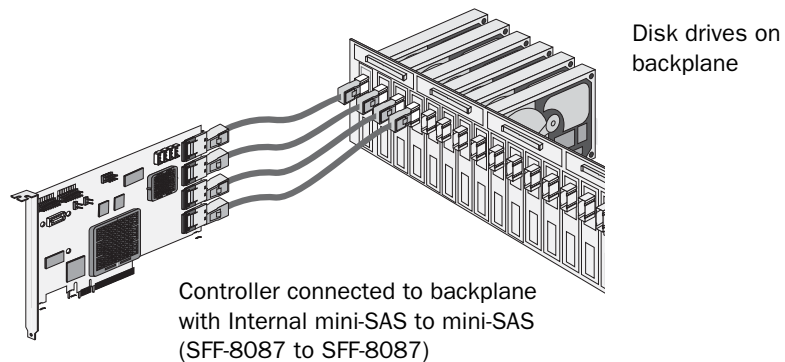

- 3 When all internal disk drives have been installed and connected, close your computer cabinet, reattach the power cord, then continue with [Connecting External Devices on page 53](#).

## Connecting Solid State Drives (SSDs)

To connect a Solid State Drive to your controller, use a direct-attached connection or a backplane connection. If your server does not have a standard 2.5-inch drive tray, you must use a bracket/SLED which enables the SSD to fit properly.

**Note:** For Adaptec maxCache applications or hybrid RAID arrays (comprised of hard drives and SSDs) you can use any Solid State Drive on the compatibility list. See [www.adaptec.com/compatibility](http://www.adaptec.com/compatibility) for a list of compatible SSDs. Adaptec maxCache is supported on Adaptec Series Q controllers only.

In a direct-attach connection (described in the steps below), you connect SSDs directly to the controller with SAS cables (mini-SAS to SATA). In a backplane connection, use the appropriate cable for your backplane type (see [page 51](#) for more about backplane connections). For maxCache caching applications, you can connect a maximum of eight maxCache-compatible SSDs to a controller. For RAID arrays, Adaptec controllers support a maximum of 256 drives, including SSDs (for details, see [page 17](#)).

- 1 Install your SSDs in your server. For servers with a standard 2.5-inch drive tray, install the SSD directly into the tray. If your server does not have a standard 2.5-inch drive tray, use a bracket or adapter which enables it to fit properly.

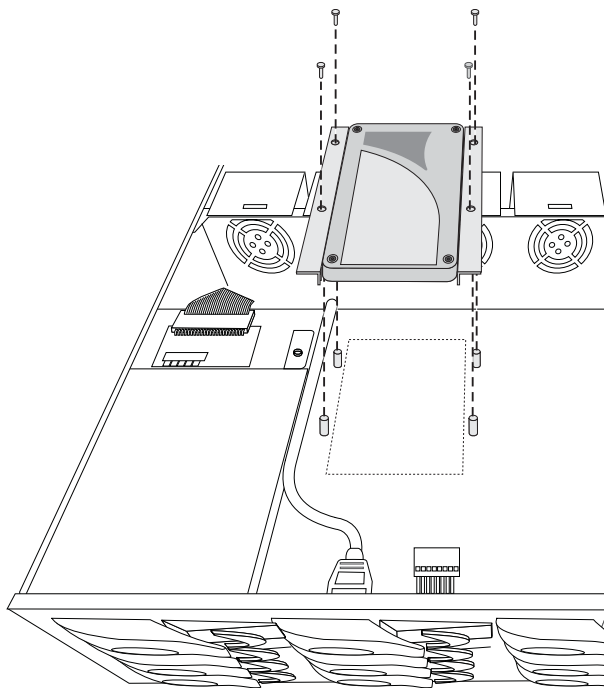

Typical SSD installation

Use a 2.5" to 3.5" adapter to install your SSD if server does not have 2.5" tray.

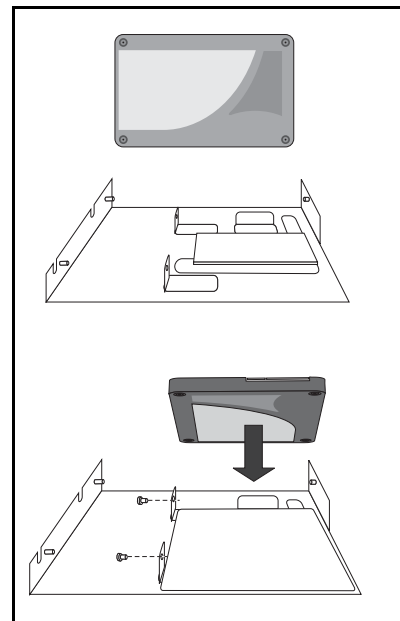

- Use an internal mini-SAS to SATA cable to attach the SSD(s) to the controller, as shown in the following example.

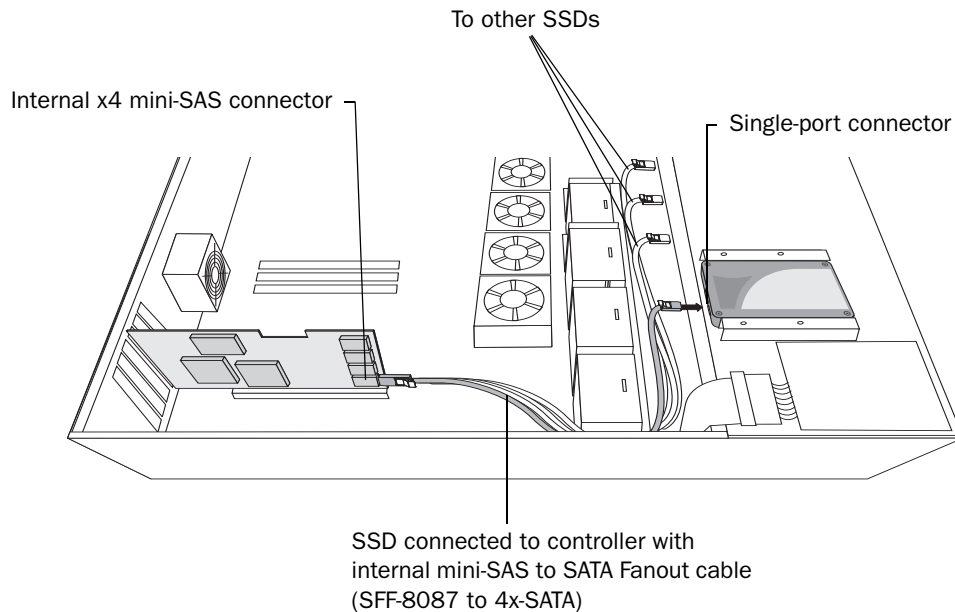

- When all SSDs have been installed and connected, close your computer cabinet, reattach the power cord, then continue with [Connecting External Devices on page 53](#).

## Connecting External Devices

**Note:** If you are not connecting any external devices, see the following section, [Next Steps](#).

Use high-quality cables to connect your controller to your external device(s), such as disk drives or disk drive enclosures.

We recommend using only Adaptec cables. For more information or to purchase cables, visit the Adaptec Web site at [www.adaptec.com](http://www.adaptec.com).

## Next Steps

If you are installing the controller driver *and* an operating system onto a bootable array, continue with [Creating a Bootable Array on page 54](#).

If you are completing a standard installation onto an existing operating system, continue with [Installing the Driver on an Existing Operating System on page 72](#).

# Creating a Bootable Array

# 6

## In this chapter...

Setting the Boot Controller.....	55
Creating an Array .....	55
Making Your Array Bootable .....	58

This chapter explains how to set your Adaptec controller to be the boot controller, and how to create a bootable array.

**Note:** If you are completing a standard installation onto an existing operating system, you don't have to complete this task. Skip to [Installing the Driver on an Existing Operating System on page 72](#).

## Setting the Boot Controller

**Note:** If your system won't contain more than one bootable controller, skip to the next section, [Creating an Array](#).

Your Adaptec RAID controller supports bootable disk drives and bootable arrays. To enable your system to boot from either a disk drive or an array connected to your controller:

- 1 Enter the system setup.
- 2 Navigate to the drive boot sequence.
- 3 Move the boot controller to the top of the list.

For more information, refer to your computer documentation.

## Creating an Array

This section explains how to create an array.

A RAID 5 array is created in the examples shown in this section because RAID 5 provides the most security and best performance with a minimum of three disk drives. However, you can choose to create an array with a different RAID level; you can also change array level later, after the operating system is installed.

You can create an array using any of these tools:

- **Array Configuration Utility (ACU)**—BIOS-based menus and keyboard navigation (see the following section).
- **Adaptec Storage Manager**—Graphical software application (running from a bootable installation DVD) that you can navigate with your mouse (see [page 80](#)).
- **ARCCONF**—Command line utility. For instructions, refer to the *Adaptec RAID Controller Command Line Utility User's Guide*.

You can use either tool, but the ACU utility is the quicker and easier tool for this task.

**Note:** We recommend that you do *not* combine SAS and SATA disk drives within the same array. Adaptec Storage Manager displays a warning if you try to create a logical drive using a combination of SAS and SATA disk drives. See [page 89](#) for more information.

### Creating an Array with the ACU

The ACU is menu-based and instructions for completing tasks appear on-screen. Menus can be navigated using the arrows, Enter, Esc, and other keys on your keyboard.

To create a RAID 5 array:

- 1 Power on your computer. When prompted, press **Ctrl+A** to enter the ARC utility.  
**Note:** During boot up, if your system has insufficient memory the following message will display. "*Adaptec RAID Configuration Utility will load after, system initialization. Please wait... Or press <Enter> Key to attempt loading the utility forcibly [Generally, not recommended]*"
- 2 If you have more than one controller of the same model or family in your computer, select your controller, then press **Enter**.
- 3 Select **Array Configuration Utility**, then press **Enter**.



- 4 Select **Initialize Drives**, then press **Enter**.
- 5 Select at least three disk drives for the array, press **Insert** for each selected disk drive, then press **Enter**.

 **Caution:** During initialization, all data is deleted from the disk. Before continuing, back up any data you want to keep.

- 6 Press **Y**, then press **Enter**.

The selected disk drives are initialized, then the ACU screen appears.

- 7 Select **Create Array**, then press **Enter**.
- 8 Select the disk drives that were just initialized, press **Insert** for each selected disk drive, then press **Enter**.
- 9 When the Array Properties screen opens, follow the instructions in the following table.

Property Line	Entry or Selection
Array Type	Select <b>RAID 5</b> , then press <b>Enter</b> .
Array Label	Type a name, then press <b>Enter</b> .
Array Size	Press <b>Enter</b> , then press <b>Enter</b> again to use the default granularity of GB.
Stripe Size	Press <b>Enter</b> to use the default (256 KB).
Read Caching	Press <b>Enter</b> to use the default (Yes).
Write Caching	Press <b>Enter</b> to use the default (Enable always).
Create RAID via	Press <b>Enter</b> to use the default (Build/Verify).
MaxCache Read	Press <b>Enter</b> to use the default (Enable Read)
[Done]	Press <b>Enter</b> .

- 10 When a cache warning message displays, type **Y**.
- 11 Once the array is created, a message displays telling you that the array can now be used. Press any key to return to the ACU Menu.

You can start using the array immediately. However, performance is reduced until the build process is complete.

- 12 Press **Esc** until the Exit utility window appears.

- 13 Select **Yes**, then press **Enter**.

The computer restarts.

- 14 Continue with *Making Your Array Bootable* on page 58.

## Creating an Array with Adaptec Storage Manager

This section describes how to use the Adaptec Storage Manager configuration wizard to build a RAID 5 array.

**Note:** You will need the Adaptec Installation DVD to complete this task.

To create a RAID 5 array:

- 1 Insert the Adaptec Installation DVD into your DVD drive, then restart your computer.
- 2 When prompted, select the language you want, then press **Enter**.
- 3 Review the license information, then press **Enter**.

The main menu opens.

- 4 Click **Launch Configuration Utility**.

Adaptec Storage Manager opens.

- 5 Click **Create**.

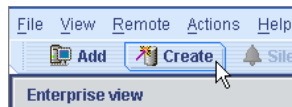

The Configuration wizard opens.

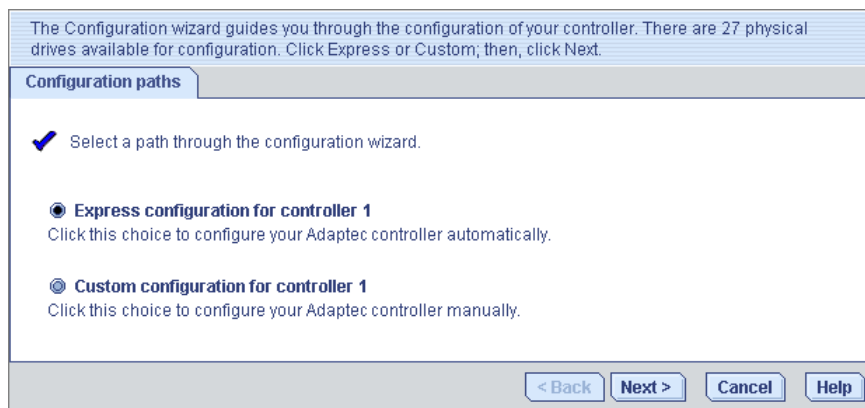

- 6 Select **Express configuration...**, then click **Next**.

- Review the information that is displayed.

**Note:** In DAS environments, Adaptec Storage Manager uses the term *logical drives* when referring to *arrays* (see [page 13](#)).

In this example, Adaptec Storage Manager has used thirteen equal-sized disk drives to automatically create one logical drive with RAID 5 and a hot spare.

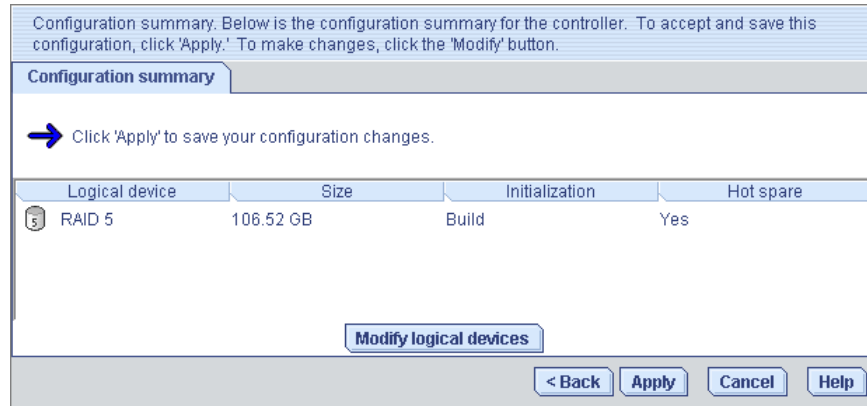

To exclude specific disk drives from the logical drive, specify a size for the logical drive, or to make other changes to the configuration, click **Modify logical devices**.

- Click **Apply**, then click **Yes** when prompted to confirm applying your new configuration.

Adaptec Storage Manager builds the logical drive.

The configuration is saved on the Adaptec controller (as an “array”, see [page 13](#)) and on the physical disk drives.

- Partition and format your logical drive.

The logical drive you created appears as a physical disk drive on your operating system. You *must* partition and format these logical drives before you can use them to store data.

- Close all windows, then click **Reboot** to restart your system.

- Remove the Adaptec Installation DVD.

For information on installing and using Adaptec Storage Manager as a full software application, refer to the *Adaptec Storage Manager User's Guide* or online Help.

- Continue with the following section.

## Making Your Array Bootable

Use the ACU to make the array bootable (see [Creating Bootable Arrays on page 106](#)).

Then continue with [Installing the Driver and an Operating System on page 59](#).

# Installing the Driver and an Operating System

# 7

**In this chapter...**

- Before You Begin ..... 60
- Creating a Driver Disk ..... 60
- Installing with Windows ..... 61
- Installing with Red Hat Linux 5..... 62
- Installing with Red Hat Linux 6 or Fedora Linux..... 62
- Installing with SuSE Linux..... 63
- Installing with Debian Linux..... 63
- Installing with Ubuntu Linux..... 65
- Installing with Solaris..... 67
- Installing with VMware ESX 4..... 67
- Installing with VMware ESXi 5 ..... 68
- Installing with FreeBSD ..... 71

This chapter explains how to install your Adaptec RAID controller driver and an operating system on a bootable array (see [page 54](#)).

To install the driver on an existing operating system, see [page 72](#).

## Before You Begin

- Install and connect your Adaptec RAID controller and internal disk drives (see [page 46](#)).
- Create a bootable array (see [page 54](#)).
- Create a driver disk (see the following section).

**Note:** Not all operating systems are supported on all controllers. For up-to-date operating system version support, visit the Adaptec Web Site at [www.adaptec.com](http://www.adaptec.com). From the main menu select Support>Knowledgebase>Find Answers. Select your controller type and OS to generate a list of supported operating systems and to download the latest drivers.

## Creating a Driver Disk

This section describes how to create a driver disk for most supported operating systems. You will need a floppy disk, USB flash drive, or writable CD to complete this task.

**Note:** Some operating systems do not require a separate driver disk, including Windows Vista, Windows Server 2008, and Windows 7; with these OSs, the driver is loaded right from the Adaptec Installation DVD. For other operating systems, including VMware, Debian Linux, and Ubuntu Linux, you must create the driver disk manually. Since the driver image is too large to fit on a floppy disk, you must use a USB flash drive (“USB stick”) or a writable CD. For details, see the instructions for your operating system, as described below.

To create a driver disk:

- 1 Set your system BIOS so that your computer boots from the DVD drive.
- 2 Turn on your computer, then insert the Adaptec Installation DVD included in your RAID controller kit.
- 3 Click **Create Diskette**, then select your operating system and version.
- 4 When prompted, insert a floppy disk, then click **OK**.

The system creates the driver disk.

- 5 Remove and label the driver disk.

Continue with the instructions for your operating system:

- For Windows, see [page 61](#).
- For Red Hat Linux 5, see [page 62](#).
- For Red Hat Linux 6 or Fedora Linux, see [page 62](#).
- For SuSE Linux, see [page 63](#).
- For Debian Linux, see [page 63](#).
- For Ubuntu Linux, see [page 65](#).
- For Solaris, see [page 67](#).
- For VMware ESX 4, see [page 67](#).
- For VMware ESXi 5, see [page 68](#).
- For FreeBSD, see [page 71](#).

## Installing with Windows

**Note:** You will need your Windows Installation CD to complete this task.

### Installing with Windows Server 2003

To install the Adaptec RAID controller driver while installing Windows:

- 1 Insert your Windows CD, then restart the computer.
- 2 Follow the on-screen instructions to begin the Windows installation.
- 3 When prompted to install a third-party driver, press F6.

**Note:** When F6 is active, a prompt appears at the bottom of the screen for only 5 seconds. If you miss your chance to press F6, restart your computer.

- 4 Insert the driver disk, then wait until you are prompted to install a driver.
- 5 Press S to specify that the driver is on a floppy disk, then press Enter.  
The computer reads the disk.
- 6 When the Adaptec driver is found, press Enter.
- 7 Follow the on-screen instructions to complete the installation.
- 8 Continue with [Managing Your Storage Space on page 79](#).

### Installing with Windows Server 2008, Windows 7, or Windows Vista

To install the Adaptec RAID controller driver while installing Windows:

- 1 Insert your Windows CD, then restart the computer.
- 2 Follow the on-screen instructions to begin the Windows installation.
- 3 When prompted to specify a location for Windows, select **Load Driver**.
- 4 Insert the Adaptec Installation DVD, browse to the driver location, then click **OK**.

**Note:** The 64-Bit driver is located within the AMD64 folder.

- 5 When the Adaptec driver is found, press **Next**.

**Note:** With Adaptec Series 6 controllers, you may see the message 'No drives were found'. Repeat [Step 3](#), [Step 4](#) (without reinserting the DVD), and [Step 5](#). On the second attempt, the driver will load successfully.

- 6 Click **Next** again to accept the default partition configuration, or refer to your Windows documentation to configure partitions manually.
- 7 Follow the on-screen instructions to complete the installation.
- 8 Continue with [Managing Your Storage Space on page 79](#).

## Installing with Red Hat Linux 5

**Note:** You will need your Red Hat 5 Installation CD to complete this task.

To install the Adaptec RAID controller driver while installing Red Hat Linux 5:

- 1 Insert the first Red Hat Installation CD.
- 2 Restart your computer.
- 3 When the Red Hat Welcome screen appears, type `linux dd` at the Boot: prompt.
- 4 When prompted, insert the driver disk, then select **OK**.
- 5 Follow the prompts to set up the environment you want.
- 6 If you are installing other third-party devices, install them now. Otherwise, select **Done**.
- 7 Complete the Linux installation, following the instructions included with your operating system.
- 8 Continue with [Managing Your Storage Space on page 79](#).

## Installing with Red Hat Linux 6 or Fedora Linux

**Note:** You will need your Red Hat 6 or Fedora Installation CD to complete this task. You must have root privileges to install the driver image.

To install the Adaptec RAID controller driver while installing Red Hat 6 or Fedora Linux:

- 1 Insert the Red Hat or Fedora Installation CD.
- 2 Restart your computer.
- 3 When the Welcome screen appears, press **Enter**, wait for the graphical installation to begin, then type **CTRL+ALT+F2** to switch to the shell. Do not pass the `linux dd` boot prompt. Do not click **Next**!
- 4 Insert the driver disk.
- 5 Type the following commands to load the controller driver:

```
mkdir /mnt2 /AACRAID
mount /dev/fd0 /mnt2
cp -r /mnt2/* /AACRAID
umount /mnt2
cd /AACRAID
sh ./fc-pre-install.sh
```

**Note:** These commands assume the floppy drive is assigned to `/dev/fd0`. Use `fdisk -l` to list all devices.

- 6 Press **ALT+F6** to switch back to the installation screen, then click **Next**.
- 7 Follow the on-screen prompts to continue the installation. When prompted to reboot the system, press **CTRL+ALT+F2** to switch to the console. Do not reboot!

- 8 Type the following commands to complete the driver installation:

```
mkdir /mnt/sysimage/tmp/AACRAID
cp -r /AACRAID/* /mnt/sysimage/tmp/AACRAID
chroot /mnt/sysimage/
cd /tmp/AACRAID
sh ./fc-post-install.sh
exit
```

- 9 Press **ALT+F6** to switch back to the installation screen, finish the installation, then reboot.
- 10 Continue with [Managing Your Storage Space on page 79](#).

## Installing with SuSE Linux

To install the Adaptec RAID controller driver while installing SuSE Linux:

- 1 Insert the first SuSE Installation CD.
- 2 Restart your computer.
- 3 When the SuSE installation selection screen appears, choose the type of installation you want, then press the **F6** key to indicate the use of a driver disk. (If **F6** is not shown on the screen, you may have an older version of SuSE; press the **Alt** key instead.)
- 4 When prompted, insert the driver disk, then press any key to continue.
- 5 Follow the prompts to set up the environment you want.
- 6 If you are installing other third-party devices, install them now. Otherwise, select **Back**.
- 7 Complete the Linux installation, following the instructions included with your operating system.

**Note:** For SuSE Linux 11, switch to the console by typing **CTRL+ALT+F2** when the installation is 50%-90% complete, type this command:

```
cp -a /update/install /mnt/tmp
```

...then press **CTRL+ALT+F7** to return to the installation screen and complete the installation as usual.

- 8 Continue with [Managing Your Storage Space on page 79](#).

## Installing with Debian Linux

**Note:** You will need your Debian Installation CD and a USB flash drive to complete this task. You must have root privileges to install the driver image.

To install the Adaptec RAID controller driver while installing Debian Linux:

- 1 Create the driver disk:
  - a Insert and mount the Adaptec Installation DVD:

```
mount /dev/cdrom /mnt/cdrom
```



- b** Insert and mount a USB flash drive:

```
mount /dev/sda1 /mnt/aacraid-driver
```

- c** Change to the Linux driver directory on the Adaptec Installation DVD, locate the .tgz archive file for your Debian operating system version (32-bit or 64-bit), then extract the contents of the archive to a temporary location.

- d** Copy the contents of the archive to the USB drive by typing this command:

```
cp /<tempdir>/* /mnt/aacraid-driver
```

where *tempdir* is the temporary location of the driver files.

- e** Unmount and remove the Adaptec Installation DVD and the USB drive.

- 2** Insert the Debian Installation CD, then restart your computer.

- 3** When the Welcome screen appears, select **Graphical Install**, then type **CTRL+ALT+F2** to switch to the console.

- 4** Insert the USB drive, then type the following command to scan for the device:

```
fdisk -l
```

**Note:** The following steps assume that the USB drive is assigned to `/dev/sda1`.

- 5** Type the following commands to begin loading the driver:

```
mkdir /mnt2 /AACRAID
mount /dev/sda1 /mnt2
cp -R /mnt2/* /AACRAID
umount /mnt2
```

- 6** Copy the driver file to the `/lib/modules` directory:

For Debian 32-bit:

```
cp -f /AACRAID/aacraid.ko-PRE_MOD /lib/modules/2.6.26-2-486/kernel/drivers/
scsi/aacraid/aacraid.ko
```

For Debian 64-bit:

```
cp -f /AACRAID/aacraid.ko /lib/modules/2.6.26-2-amd64/kernel/drivers/scsi/
aacraid/aacraid.ko
```

- 7** Remove the USB drive.

- 8** Install the loadable module:

For Debian 32-bit:

```
insmod /lib/modules/2.6.26-2-486/kernel/drivers/scsi/aacraid/aacraid.ko
```

For Debian 64-bit:

```
insmod /lib/modules/2.6.26-2-amd64/kernel/drivers/scsi/aacraid/aacraid.ko
```

- 9** Press **CTRL+ALT+F5** to switch back to the installation screen, then follow the on-screen prompts to continue the installation.

- 10** When prompted to reboot the system, press **CTRL+ALT+F2** to switch to the console. Do not reboot!

- 11** Type the following commands to complete the driver installation:

For Debian 32-bit:

```
cp -f /AACRAID/aacraid.ko-POST_MOD /target/lib/modules/2.6.26-2-686/kernel/
drivers/scsi/aacraid/aacraid.ko
chroot /target
/sbin/depmod -a 2.6.26-2-686
update-initramfs -u -v
exit
```

For Debian 64-bit:

```
cp -f /AACRAID/aacraid.ko /target/lib/modules/2.6.26-2-amd64/kernel/drivers/
scsi/aacraid/aacraid.ko
chroot /target
/sbin/depmod -a 2.6.26-2-amd64
update-initramfs -u -v
exit
```

- 12** Press CTRL+ALT+F5 to switch back to the installation screen, then reboot.

- 13** Continue with [Managing Your Storage Space on page 79](#).

## Installing with Ubuntu Linux

**Note:** You will need your Ubuntu Installation CD and a USB flash drive to complete this task. You must have root privileges to install the driver image.

To install the Adaptec RAID controller driver while installing Ubuntu Linux:

- 1** Create the driver disk:
  - a** Insert and mount the Adaptec Installation DVD:
 

```
mount /dev/cdrom /mnt/cdrom
```
  - b** Insert and mount a USB flash drive:
 

```
mount /dev/sda1 /mnt/aacraid-driver
```
  - c** Change to the Linux driver directory on the Adaptec Installation DVD, locate the .tgz archive file for your Ubuntu operating system version (32-bit or 64-bit), then extract the contents of the archive to a temporary location.
  - d** Copy the contents of the archive to the USB drive by typing this command:
 

```
cp /<tempdir>/* /mnt/aacraid-driver
```

 where *tempdir* is the temporary location of the driver files.
  - e** Unmount and remove the Adaptec Installation DVD and the USB drive.
- 2** Insert the Ubuntu Installation CD, then restart your computer.
- 3** When the Welcome screen appears, select **Install Ubuntu Server**, then type CTRL+ALT+F2 to switch to the console.
- 4** Insert the USB drive, then type the following command to scan for the device:

```
fdisk -l
```

**Note:** The following steps assume that the USB drive is assigned to /dev/sda1.

- 5 Type the following commands to begin loading the driver:

```
mkdir /mnt2 /AACRAID
mount /dev/sda1 /mnt2
cp -R /mnt2/* /AACRAID
umount /mnt2
```

- 6 Copy the driver file to the /lib/modules directory:

```
cp -f /AACRAID/aacraid.ko-PRE_MOD /lib/modules/2.6.<version>-generic/kernel/
drivers/scsi/aacraid/aacraid.ko
```

where <version> is 32-24 for Ubuntu 10.x and 38-8 for Ubuntu 11.x.

- 7 Remove the USB drive.

- 8 Install the loadable module:

```
insmod /lib/modules/2.6.<version>-generic/kernel/drivers/scsi/aacraid/
aacraid.ko
```

where <version> is 32-24 for Ubuntu 10.x and 38-8 for Ubuntu 11.x.

- 9 Press CTRL+ALT+F1 to switch back to the installation screen, then follow the on-screen prompts to continue the installation.

- 10 When prompted to reboot the system, press CTRL+ALT+F2 to switch to the console. Do not reboot!

- 11 Type the following commands to complete the driver installation:

For Ubuntu 32-bit:

```
cp -f /AACRAID/aacraid.ko-POST_MOD /target/lib/modules/2.6.<version>-generic-
pae/kernel/drivers/scsi/aacraid/aacraid.ko
chroot /target
/sbin/depmod -a 2.6.<version>-generic-pae
update-initramfs -u -v
exit
```

where <version> is 32-24 for Ubuntu 10.x and 38-8 for Ubuntu 11.x.

For Ubuntu 64-bit:

```
cp -f /AACRAID/aacraid.ko-POST_MOD /target/lib/modules/2.6.<version>-server/
kernel/drivers/scsi/aacraid/aacraid.ko
chroot /target
/sbin/depmod -a 2.6.<version>-server
update-initramfs -u -v
exit
```

where <version> is 32-24 for Ubuntu 10.x and 38-8 for Ubuntu 11.x.

- 12 Press CTRL+ALT+F1 to switch back to the installation screen, then reboot.

- 13 Continue with *Managing Your Storage Space* on page 79.

## Installing with Solaris

**Note:** This task is not necessary if you are installing Solaris 10 Update 2 or later. Instead, you can choose to install Solaris using the in-box driver and update it either during or after the installation is complete, if required.

**Note:** For systems without a floppy drive, you can create a driver disk by burning a CD with the `aac_solaris-x86.iso` file, available on the Adaptec Installation DVD.

To install the Adaptec RAID controller driver while installing Solaris:

- 1 Start your computer.
- 2 Interrupt the autoboot, press the **ESC** key. The Device Configuration Assistant (DCA) Utility will open.
- 3 Select **Apply driver updates**.
- 4 Insert the driver floppy disk or other update media, then press **Return**.
- 5 Complete the Solaris installation, following the instructions included with your operating system.

## Installing with VMware ESX 4

**Note:** Use the following procedure to install the controller driver for an Adaptec Series 6 controller with VMware ESX 4.x. This task is not necessary if you are installing the driver with an Adaptec Series 2 or Series 5 controller. Instead, you can choose to install VMware ESX 4.x using the in-box driver (which supports Series 2 and Series 5 controllers directly) and update it either during or after the installation is complete, if required.

**Note:** You will need your VMware Installation CD and a writable CD to complete this task. You must have root privileges to create the driver disk and install the driver image.

To install the Adaptec RAID controller driver when installing VMware ESX 4.x:

- 1 Create the driver disk:
  - a Insert and mount the Adaptec Installation DVD:

```
mount /dev/cdrom /mnt/cdrom
```
  - b Insert and mount a writable CD:

```
mount /dev/cdrom1 /mnt/cdrom1
```
  - c Change to the Linux driver directory on the Adaptec Installation DVD, locate the VMware iso image, `vmware-aacraid-400.4.1.7.28300-esx4.1.iso`, then burn the iso to the CD.

**Note:** Use whatever tool you prefer to burn the CD, such as an interactive (GUI-based) tool or the Linux command line.
  - d Unmount and remove the Adaptec Installation DVD and the driver CD.
- 2 Insert the VMware Installation CD.
- 3 Restart your computer.
- 4 Follow the on-screen instructions to begin the VMware installation.

- 5 Select **Yes** to install a custom driver, then click **Add**.
- 6 Insert the driver disk, then click **OK**.
- 7 Select the driver from the displayed list, click **OK**, then follow the on-screen instructions to load the driver.
- 8 Complete the VMware installation, following the on-screen instructions.
- 9 Reboot your computer, then remove the VMware Installation CD.

**Note:** You may see a warning that the controller driver is not certified by VMware (no signature attached). You can ignore this message.

**Note:** For information about creating and managing arrays under VMware, see [page 81](#).

## Installing with VMware ESXi 5

**Note:** Use the following procedure to install the controller driver for an Adaptec Series 6 controller with VMware ESXi 5. This task is not necessary if you are installing the driver with an Adaptec Series 2 or Series 5 controller. Instead, you can choose to install VMware ESXi 5 using the in-box driver (which supports Series 2 and Series 5 controllers directly) and update it either during or after the installation is complete, if required.

To install the Adaptec RAID controller driver with VMware ESXi 5, you must create a custom boot image using the VMware Image Builder. The VMware Image Builder is distributed as a snap-in component for vSphere PowerCLI, a command-line and scripting tool from VMware based on Microsoft PowerShell.

You can download PowerCLI from the VMware Download Center at [www.vmware.com/downloads](http://www.vmware.com/downloads). To perform the installation, you will also need to download the VMware ESXi5.0 Standard Software Depot from the VMware Download Center.

**Note:** You will need a writable CD to complete this task. You must have administrator privileges to create the driver disk and install the driver image.

**Note:** In the following instructions, perform [Steps 1-7](#) on your Windows build machine—the machine used to build the custom boot image—and [Steps 8-11](#) on the machine where you want to install the custom image. Be sure to install the prerequisite software first, including Powershell and Microsoft .NET 2.0, before you install PowerCLI or start to create the custom boot image.

To install the Adaptec RAID controller driver when installing VMware ESXi 5:

- 1 Download Microsoft PowerShell and Microsoft .NET 2.0 (if not installed on your machine already) and install on your Windows build machine. You can download PowerShell and Microsoft .NET from the Microsoft Download Center at [www.microsoft.com/download](http://www.microsoft.com/download).

**Note:** PowerShell is preinstalled on Windows 2008 and Windows 7 systems.

- 2 Run PowerShell as Administrator, then set the execution policy to Remote Signed:

```
# Set-ExecutionPolicy RemoteSigned
```

- 3 Download and install vSphere PowerCLI on your Windows build machine. You can download PowerCLI from the VMware Download Center at [www.vmware.com/downloads](http://www.vmware.com/downloads) (for example, `VMware-PowerCLI-5.0.0-374833.exe`).

- 4 Download the VMware ESXi5.0 Standard Software Depot (for example, `vmware-ESXi-5.0.0-469512-depot.zip`) and store in a temporary location on your Windows build machine. You can download the software depot from the VMware Download Center at [www.vmware.com/downloads](http://www.vmware.com/downloads); when you start the download, be sure to choose “ESXi Offline Bundle”.

**Note:** You may need to provide account credentials to download the software depot from the VMware Web site.

- 5 Insert the Adaptec Installation DVD, navigate to the Linux driver folder, then copy the Adaptec AACRAID driver binary, `aacraid-esxi5.0-1.1.7.28400.zip`, to a temporary location on the Windows build machine.

**Note:** The version string in the file name may differ from the one above.

After you copy the file, remove the Adaptec Installation DVD.

- 6 Launch vSphere PowerCLI, then follow the steps below to create the custom boot image:

- a At the PowerCLI prompt, add the VMware Image Builder snap-in by running the following cmdlet:

```
# Add-PSSnapIn VMware.ImageBuilder
```

**Note:** You will see a message if the Image Builder snap-in is already installed. You can ignore this message.

**Note:** Continue using PowerCLI in [Steps 6b](#) through [6j](#).

- b Add the VMware ESXi5.0 Software Depots:

```
# Add-EsxSoftwareDepot C:\ESXi5.0-PMC-CustomISO\vmware-ESXi-5.0.0-469512-depot.zip
```

where `C:\ESXi5.0-PMC-CustomISO` is the temporary folder on your build machine where the software depot is stored.

- c Add the AACRAID driver binary as a software depot:

```
# Add-EsxSoftwareDepot C:\ESXi5.0-PMC-CustomISO\aacraid-esxi5.0-1.1.7.28400.zip
```

where `C:\ESXi5.0-PMC-CustomISO` is the temporary folder on your build machine where the software depot is stored.

- d Verify that the software depots are added:

```
# $DefaultSoftwareDepots
```

- e List ESX Image Profiles:

```
# Get-EsxImageProfile
```

You should see a display like this:

```
ESXi-5.0.0-469512-no-tools
ESXi-5.0.0-469512-standard
```

- f** Create a copy of the standard image profile, using the `-CloneProfile` option:

```
# New-EsxImageProfile -CloneProfile ESXi-5.0.0-469512-standard -Name "ESXi
5.0 Adaptec Series 6"
```

- g** Change the vendor and acceptance level of the new image profile:

```
# Set-EsxImageProfile -ImageProfile "ESXi 5.0 Adaptec Series 6" -vendor
PMC-Sierra -AcceptanceLevel communitysupported
```

- h** Check if the new driver package is available:

```
# Get-EsxSoftwarePackage
```

You should see a line like this:

```
scsi-aacraid 5.0.5.1.7.28400-10EM.500.0... Adaptec 19.08.2011
```

- i** Add the `scsi-aacraid` software package to the new image profile:

```
# Add-EsxSoftwarePackage -ImageProfile "ESXi 5.0 Adaptec Series 6"
-SoftwarePackage scsi-aacraid
```

- j** Export the custom ISO image:

```
# Export-EsxImageProfile -ImageProfile "ESXi 5.0 Adaptec Series 6"
-FilePath C:\ESXi5.0-PMC-CustomISO\ESXi5.0-PMC-Sierra-Series-6.iso
-ExportToISO
```

where `-FilePath` specifies the path to the custom iso image (C:\ESXi5.0-PMC-CustomISO\ESXi5.0-PMC-Sierra-Series-6.iso in this example).

- 7** Burn the custom ISO image to a writable CD.

**Note:** Use whatever tool you prefer to burn the CD, such as an interactive (GUI-based) tool or a command line tool.

Remove the CD after you finish burning the image.

- 8** On the VMware ESXi machine, insert the custom boot CD, then restart your computer.
- 9** Follow the on-screen instructions to begin the VMware installation.
- 10** Complete the VMware installation, following the on-screen instructions.
- 11** Remove the custom boot CD, then reboot your computer.

**Note:** For information about creating and managing arrays under VMware, see [page 81](#).

## Installing with FreeBSD

**Note:** You will need your FreeBSD Installation CD to complete this task.

To install the Adaptec RAID controller driver when installing FreeBSD:

- 1 Insert the FreeBSD Installation CD.
- 2 Restart your computer.
- 3 When the FreeBSD start screen opens, select 6 to escape to loader prompt.
- 4 Type `load kernel`.
- 5 Insert the driver floppy disk.
- 6 Type this command:

```
load disk0:aacu.ko
```

**Note:** If the driver fails to load, run `lsdev` and check for the floppy disk drive. Then, try again with the appropriate device.

- 7 Type `boot`.
- 8 Complete the FreeBSD installation, following the instructions included with your operating system.
- 9 Reboot your computer, then remove the driver disk.
- 10 Repeat Steps 3 through 7 the first time you boot the operating system to load the driver again.

**Note:** To avoid loading the driver each time you boot, follow the instructions on [page 78](#) for updating the driver on an existing FreeBSD installation. Alternatively, you can statically link the driver. See your operating system documentation for details.

---



# Installing the Driver on an Existing Operating System

---



## In this chapter...

Before You Begin .....	73
Creating a Driver Disk .....	73
Installing on Windows .....	74
Installing on Red Hat, SuSE, or Fedora Linux.....	74
Installing on Debian Linux .....	75
Installing on Ubuntu Linux.....	75
Installing on Solaris.....	76
Installing on VMware.....	76
Installing on FreeBSD .....	78

This chapter explains how to install your Adaptec RAID controller driver.

**Note:** To install the driver while you're installing an operating system, see [page 59](#).

## Before You Begin

Before you begin, install and connect your Adaptec RAID controller and internal disk drives (see [page 46](#)).

You must also create a driver disk before you begin installing the controller driver.

**Note:** Not all operating systems are supported on all controllers. For up-to-date operating system version support, visit the Adaptec Web Site at [www.adaptec.com](http://www.adaptec.com). From the main menu select Support>Knowledgebase>Find Answers. Select your controller type and OS support to generate a list of supported operating systems and to download the latest drivers.

## Creating a Driver Disk

This section describes how to create a driver disk for most supported operating systems. You will need a floppy disk to complete this task.

**Note:** Some operating systems do not require a separate driver disk; they load the driver right from the Adaptec Installation DVD or from the OS installation CD (Debian, for instance). For other operating systems, such as VMware and FreeBSD, you must copy the driver from the installation DVD and install it from the local system.

To create a driver disk:

- 1 Set your system BIOS so that your computer boots from the DVD drive. (For instructions, refer to your computer documentation.)
- 2 Turn on your computer, then insert the Adaptec Installation DVD included in your RAID controller kit.
- 3 Click **Create Diskette**, then select your operating system and version.
- 4 When prompted, insert a floppy disk, then click **OK**.

The system creates the driver disk.

- 5 Remove and label the driver disk.

Continue with the instructions for your operating system:

- For Windows, see [page 74](#).
  - For Red Hat, SuSE, or Fedora Linux, see [page 74](#).
  - For Debian Linux, see [page 75](#).
  - For Ubuntu Linux, see [page 75](#).
  - For Solaris, see [page 76](#).
  - For VMware, see [page 76](#).
  - For FreeBSD, see [page 78](#).
-

## Installing on Windows

Follow the instructions in this section for your version of Windows.

### Installing on Windows Server 2003

To install the driver on Windows:

- 1 Start or restart Windows.  
The Found New Hardware Wizard opens and searches for the driver.
- 2 Insert the driver disk, select **Floppy drive**, then click **Next**.
- 3 Click **Next**, then click **Next** again.
- 4 Follow the on-screen instructions to complete the driver installation.
- 5 Remove the driver disk and restart your computer.
- 6 Continue with [Managing Your Storage Space on page 79](#).

### Installing on Windows Server 2008, Windows 7, or Windows Vista

- 1 Start or restart Windows.  
The Found New Hardware Wizard opens and searches for the driver.
- 2 Insert the driver disk, then select **Locate and Install Driver Software....** and **Don't Search Online**.
- 3 Click **Next**, then click **Close**.
- 4 When the installation is complete, remove the driver disk and restart your computer.
- 5 Continue with [Managing Your Storage Space on page 79](#).

## Installing on Red Hat, SuSE, or Fedora Linux

To install the driver on Red Hat Linux, SuSE Linux, or Fedora Linux:

- 1 Insert and mount the Adaptec Installation DVD:

```
Red Hat: mount /dev/cdrom /mnt/cdrom
SuSE:    mount /dev/cdrom /media/cdrom
Fedora:  mount /dev/hdc /mnt/cdrom
```

- 2 Install the module RPM:

```
rpm -ivh mount-point/xxx/yyy.rpm
```

where *mount-point* is the specific mount point on the Linux system, *xxx* is the driver path, and *yyy.rpm* is the rpm file.

- 3 Reboot your computer to ensure the driver loaded correctly.
- 4 Run `fdisk`, `mkfs`, and create mount points for any new disk drives.
- 5 Continue with [Managing Your Storage Space on page 79](#).

## Installing on Debian Linux

**Note:** You must have root privileges to install the driver image. For Debian Linux, the `su` command is sufficient.

To install the driver on Debian Linux:

- 1 Insert and mount the Debian Installation DVD:

```
mount /dev/cdrom /mnt/cdrom
```

- 2 Load the Debian unpacking tools:

```
apt-get install build-essential
```

- 3 Install the DEB driver package:

For Debian Linux 5.x:

```
dpkg -i aacraid-Debian+Ubuntu-all.deb
```

For Debian Linux 6.x:

```
dpkg -i aacraid-Debian6.0-all.deb
```

- 4 Reboot your computer to ensure the driver loaded correctly.
- 5 Continue with [Managing Your Storage Space on page 79](#).

## Installing on Ubuntu Linux

**Note:** For driver installation on Ubuntu Linux, you may need to create the root account and password. Enter these commands: `sudo bash`; `sudo passwd root`. You must have root privileges to install the driver image.

To install the driver on Ubuntu Linux:

- 1 Update the Ubuntu package index:

```
sudo apt-get update
```

- 2 Load the Ubuntu unpacking tools:

```
sudo apt-get install build-essential
```

- 3 Install the DEB driver package:

For Ubuntu Linux 10.x:

```
sudo dpkg -i aacraid-Debian+Ubuntu-all.deb
```

For Ubuntu Linux 11.x:

```
sudo dpkg -i aacraid-Ubuntu11.04-all.deb
```

- 4 Reboot your computer to ensure the driver loaded correctly.
- 5 Continue with [Managing Your Storage Space on page 79](#).

## Installing on Solaris

To install the driver on Solaris:

- 1 Start your computer.
- 2 (*Solaris 10 only*) Check for any pre-existing Adaptec driver by performing a `pkginfo SUNWaac` in a terminal window. If there is no pre-existing Adaptec driver on your computer, continue with [Step 3](#). If an Adaptec driver is already installed on your computer, perform a `pkgrm SUNWaac` to remove it.

 **Caution:** If your operating system currently boots from the Adaptec controller, *do not* reset your computer after you remove the pre-existing Adaptec driver. Instead, follow the steps in this section to install a new driver before rebooting your computer.

- 3 Insert and mount the driver disk:

```
volcheck
```

- 4 Change to the driver installer directory:

On Solaris 10:

```
cd /rmdisk/aacraid/DU/sol_210/i86pc/Tools
```

On Solaris 11:

```
cd /rmdisk/aacraid/DU/sol_211/i86pc/Tools
```

- 5 Start the driver installer:

```
./install.sh -i
```

- 6 Remove the driver disk, then reboot your computer.
- 7 Continue with [Managing Your Storage Space on page 79](#).

## Installing on VMware

**Note:** You must remove the old driver before you can install the new one. You must have root privilege to install the new driver.

**Note:** To copy the driver VIB file to the VMware ESX/ESXi server (in [Step 2](#) below), you must have access to a remote copy utility, such as WinSCP, putty, or Linux scp.

To install the driver on VMware:

- 1 At the VMware console screen, type these commands to remove the old driver:

VMware ESX/ESXi 4.1:

```
esxupdate query --vib-view | grep -i aacraid    (list driver packages)
esxupdate -b <vibID> --maintenance-mode remove    (remove package)
```

where *vibID* is the full name of the driver package.

**Note:** For VMware 4.0 or earlier, use the `rpm -e` command to remove the driver.

VMware ESXi 5:

```
esxcli software vib list    (list driver packages)
esxcli software vib remove --vibName=scsi-aacraid --maintenance-mode    (remove package)
```

- 2 Using a remote copy utility, copy the driver VIB file for your operating system version from the Linux driver folder on the installation DVD to a local directory on the ESX server. This example uses Linux `scp` to copy the driver to `/tmp/aacraid`:

VMware ESX 4:

```
scp /mnt/cdrom/linux/driver/vmware-esx-drivers-scsi-aacraid-400.4.1.7.28300-1.0.4.260247.x86_64.vib root@<esx-server-ip>:/tmp/aacraid
```

VMware ESXi 4:

```
scp /mnt/cdrom/linux/driver/vmware-esxi-drivers-scsi-aacraid-400.4.1.7.28300-1.0.4.260247.x86_64.vib root@<esx-server-ip>:/tmp/aacraid
```

VMware ESXi 5:

```
scp /mnt/cdrom/linux/driver/vmware-esxi-drivers-scsi-aacraid-500.5.1.7.28300.-1.0.5.406165.x86_64.vib root@<esx-server-ip>:/tmp/aacraid
```

**Note:** Due to file name limits on the installation DVD, the “\_64.vib” portion of the file name may be truncated and not visible. Also, the version string may be different from above.

- 3 Install the VIB module:

VMware ESX 4:

```
esxupdate -b /tmp/aacraid/vmware-esx-drivers-scsi-aacraid-400.4.1.7.28300-1.0.4.260247.x86_64.vib --nodeps --nosigcheck --maintenancemode update
```

VMware ESXi 4:

```
esxupdate -b /tmp/aacraid/vmware-esxi-drivers-scsi-aacraid-400.4.1.7.28300-1.0.4.260247.x86_64.vib --nodeps --nosigcheck --maintenancemode update
```

VMware ESXi 5:

```
esxcli software vib install -f -v file:/tmp/aacraid/vmware-esxi-drivers-scsi-aacraid-500.5.1.7.28300.-1.0.5.406165.x86_64.vib
```

- 4 Reboot your computer.

**Note:** For information about creating and managing arrays under VMware, see [page 81](#).

## Installing on FreeBSD

To install the driver on FreeBSD:

- 1 Start your computer.
- 2 Insert and mount the driver disk:  

```
mount -t msdos /dev/fd0 /mnt
```
- 3 Copy the driver package to the /tmp directory:  

```
cp /mnt/aac8x-i386.tgz /tmp
```
- 4 Install the driver package:  

```
pkg_add /tmp/aac8x-i386.tgz
```
- 5 Remove the driver disk, then reboot your computer.
- 6 Continue with [Managing Your Storage Space on page 79](#).

# Managing Your Storage Space

---

# 9

## **In this chapter...**

About Adaptec Storage Manager .....	80
About the Adaptec RAID Controller Configuration Utility .....	80
About the Adaptec RAID Configuration Utility.....	81
About the Adaptec Flash Utility .....	81
Which Utility Should I Use? .....	81

Once you have installed your Adaptec RAID controller, disk drives (or other devices), and device driver, you can begin to build and manage your storage space.

This chapter introduces Adaptec Storage Manager, and describes the other utilities included with your Adaptec RAID controller.



## About Adaptec Storage Manager

Adaptec Storage Manager is a full-featured software application that helps you build a storage space for your online data, using Adaptec RAID controllers and disk drives.

With Adaptec Storage Manager, you can group disk drives into logical drives and build in redundancy to protect your data and improve system performance.

From a single workstation, you can use Adaptec Storage Manager to monitor and manage all the controllers and disk drives in your storage space.

When Adaptec Storage Manager is installed on a computer, the *Adaptec Storage Manager agent* is also installed automatically. The agent is like a service that keeps your storage space running. It's designed to run in the background, without user intervention, and its job is to monitor and manage system health, event notifications, task schedules, and other on-going processes on that system. It sends notices when tasks are completed successfully, and sounds an alarm when errors or failures occur on that system.

The agent uses less memory than the full application. If your storage space includes systems that won't be connected to monitors (and therefore won't require the user interface), you can choose to run the *agent only* on those systems instead of the full application. For more information, refer to the Adaptec Storage Manager online Help, or to the *Adaptec Storage Manager User's Guide* on the Adaptec Installation DVD.

### Installing Adaptec Storage Manager

Adaptec Storage Manager is included on the Adaptec Installation DVD. For installation instructions, refer to the *Adaptec Storage Manager User's Guide*, also included on the installation DVD.

## About the Adaptec RAID Controller Configuration Utility

The Adaptec RAID Controller Configuration (ARCCONF) is a command line utility that you can use to perform basic array and configuration management functions.

With ARCCONF, you can:

- Create and delete logical drives
- Modify and copy configuration settings
- Recover from disk drive failures and troubleshoot your system

ARCCONF is described in the *Adaptec RAID Controller Command Line Utility User's Guide*, which is included on the Adaptec Installation DVD.

**Note:** The distribution includes a command line utility for VMware systems called Remote ARCCONF. For details, see [Which Utility Should I Use on VMware?](#) on page 81.

## About the Adaptec RAID Configuration Utility

The Adaptec RAID Configuration (ARC) utility is a BIOS-based utility that you can use to create and manage controllers, disk drives and other devices, and arrays. The ARC utility comprises these tools:

- **Array Configuration Utility (ACU)**—For creating and managing arrays, and initializing and rescanning disk drives.
- **SerialSelect**—For modifying your controller and disk drive settings.
- **Disk Utilities**—For formatting or verifying disk drives.

The ARC utility is included in your controller's BIOS. For more information, see [Using the Adaptec RAID Configuration Utility on page 104](#).

**Note:** The ARC utility is primarily intended for preoperating system installation configuration.

## About the Adaptec Flash Utility

The Adaptec Flash Utility (AFU) is a text-based DOS utility that you can use to update, save, or verify your RAID controller's firmware BIOS and Non-Volatile Random Access Memory (NVRAM).

 **Caution:** Although the AFU contains safeguards to prevent you from accidentally damaging your RAID controller's flash contents, it is still important to use the AFU carefully and correctly to avoid rendering your RAID controller inoperable. We recommend that only advanced users familiar with working in DOS use the AFU. You can also use Adaptec Storage Manager to update the controller firmware/BIOS. See the *Adaptec Storage Manager User's Guide* for more information.

## Which Utility Should I Use?

To create a bootable array, we recommend that you use the BIOS-based ACU (See [Using the Adaptec RAID Configuration Utility on page 104](#)).

For subsequent storage management tasks on most supported operating systems, we recommend that you install and use Adaptec Storage Manager (see [page 80](#)). As a full-featured software application with a graphical user interface, it is the easiest to use and offers the widest range of management functions.

**Note:** If your Adaptec RAID controller is connected to a VMware system, your choice of management utilities varies, depending on which version of VMware you are running; see [Which Utility Should I Use on VMware? on page 81](#) for more information.

### Which Utility Should I Use on VMware?

VMware storage management options vary, depending on which version of the operating system you are running:

- On VMware ESX 4.1 and VMware ESX 4.0 systems:
  - You can install the Adaptec Storage Manager Agent (only) on the VMware ESX system, then from a Windows or Linux machine running the Adaptec Storage Manager GUI, you can connect to the VMware system and configure and manage arrays from the remote ASM GUI.

- Additionally, you can use the ARCCONF command line utility to configure and manage arrays from the VMware ESX console.

For information on installing the Adaptec Storage Manager Agent and ARCCONF on VMware ESX 4.x systems, see the *Adaptec Storage Manager User's Guide* and the *Command Line Utility User's Guide*, included on the installation DVD.

- On VMware ESXi 5.0 and VMware ESXi 4.1 systems:
  - You can install the Adaptec CIM Provider on the VMware ESXi system, then from a Windows or Linux Guest OS, you can install *Remote ARCCONF*—a version of the command line utility designed specifically for VMware ESXi.
  - After you install Remote ARCCONF, you can configure and manage arrays from a Windows or Linux Guest OS running on your VMware ESXi system.
  - Additionally, on a Linux Guest OS, you can use the configUtil.sh utility to manage email notifications to help you monitor activity in your storage space.

For information on installing the Adaptec CIM Provider and Remote ARCCONF on a VMware ESXi 5.0 or VMware ESXi 4.1 system, see the *Command Line Utility User's Guide*, included on the installation DVD.

---

# Solving Problems

# 10

---

**In this chapter...**

Troubleshooting Checklist .....	84
Silencing the Alarm .....	84
Recovering from a Disk Drive Failure .....	85
Resetting the Controller .....	86

This chapter provides basic troubleshooting information and solutions for solving controller problems.

## Troubleshooting Checklist

If you encounter difficulties installing or using your Adaptec RAID controller, check these items first:

- With your computer powered off, check the connections to each disk drive, power supply, LED connector, and so on.  
Try disconnecting and reconnecting disk drives from the Adaptec RAID controller.
- Check that your Adaptec RAID controller is installed in a compatible PCIe expansion slot. To double-check the bus compatibility of your controller, see *About Your RAID Controller on page 17*.
- Ensure that your Adaptec RAID controller is firmly seated and secured in the PCIe expansion slot.
- If your Adaptec RAID controller is not detected during system boot, try installing it in a different compatible expansion slot. (See *page 47* for instructions.)
- Did the driver install correctly?
- If you have external disk drives (or other devices), are they powered on?
- Check the Readme on the installation DVD for compatibility issues and known problems.

If you are still unable to resolve a problem, you can find additional troubleshooting information and direction on the Adaptec Web site at [www.adaptec.com](http://www.adaptec.com) or the Support Knowledgebase at [ask.adaptec.com](http://ask.adaptec.com).

## Monitoring Disk Drives Status

You can use the 'blink' feature of Adaptec Storage Manager to monitor the status of your SAS and SATA disk drives. When you blink a specific disk drive or set of disk drives, the LED(s) on the selected disk drives flash.

This table describes the LED flash states.

Controller Device State	Slot State	LED Flash State
Failed	Device is faulty	On
Rebuilding	Device is rebuilding	Slow flash
Blink	Identify the device	Fast flash
Other	No error	Off

For more information about backplanes, see *Backplane Connections on page 92*. For more information about using Adaptec Storage Manager to monitor your disk drives, refer to the *Adaptec Storage Manager User's Guide* or the online Help.

## Silencing the Alarm

If your Adaptec RAID controller includes an alarm, the alarm will sound when an error occurs. To silence the alarm, use Adaptec Storage Manager (see *Managing Your Storage Space on page 79*.) OR SerialSelect (see *Modifying Your Controller's Configuration on page 110*.)

## Recovering from a Disk Drive Failure

This section explains how to recover when a disk drive fails:

- If the array was protected by a hot spare (see [page 85](#)).
- If the array was *not* protected by a hot spare (see [page 85](#)).
- If there is a disk drive failure in more than one array simultaneously (see [page 85](#)).
- If it is a RAID 0 array (see [page 86](#)).
- If multiple disk drives fail within the same array (see [page 86](#)).
- If the drive is part of the maxCache pool (see [page 86](#)).

**Note:** Adaptec Storage Manager uses the term *logical drives* or *logical devices* when referring to *arrays* (see [page 13](#)).

### Failed Disk Drive Protected by a Hot Spare

When an array is protected by a hot spare, if a disk drive in that array fails the hot spare is automatically incorporated into the array and takes over for the failed drive.

To recover from the failure:

- 1 Remove and replace the failed disk drive.
- 2 **If copyback is not enabled**—In Adaptec Storage Manager, remove the ‘hot spare’ designation from the original hot spare (the disk drive that was built into the array). Then, designate a new hot spare to protect the arrays on that controller.

**If copyback is enabled**—Data is automatically moved back to its original location once the controller detects that the failed drive has been replaced. No action is required.

### Failed Disk Drive Not Protected by a Hot Spare

When a array is not protected by a hot spare, if a disk drive in that array fails, remove and replace the failed disk drive. The controller detects the new disk drive and begins to rebuild the array.

If the controller fails to rebuild the array, check that the cables, disk drives, and controllers are properly installed and connected. Make sure that the new disk drive is equal or greater in size than the failed disk drive. Then, if necessary, use Adaptec Storage Manager to rebuild the array. For instructions, refer to the *Adaptec Storage Manager User’s Guide* or online Help.

### Failure in Multiple Arrays Simultaneously

If there’s a disk drive failure in more than one array at the same time (one failure per array), and the arrays have hot spares protecting them, the controller rebuilds the arrays with these limitations:

- A hot spare must be of equal or greater size than the failed disk drive it’s replacing.
- Failed disk drives are replaced with hot spares in the order in which they failed. (The array that includes the disk drive that failed first is rebuilt first, assuming an appropriate hot spare is available—see bullet above.)

If there are more disk drive failures than hot spares, see *Failed Disk Drive Not Protected by a Hot Spare*.

If copyback is enabled, data is moved back to its original location once the controller detects that the failed drive has been replaced.

### Disk Drive Failure in a RAID 0 Array

Because RAID 0 volumes do not include redundancy, if a disk drive fails in a RAID 0 array, the data can't be recovered.

Correct the cause of the failure or replace the failed disk drives. Then, restore your data (if available).

### Multiple Failures in the Same Array

Except in RAID 6 and RAID 60 arrays (see [page 95](#)), if more than one disk drive fails at the same time in the same array, the data normally can't be recovered.

You *may* be able to recover the data by forcing the logical drive online or by recreating the logical drive without the initialization step. You can use the BIOS utility, ACU (see [page 81](#)), the command-line utility, ARCCONE, or Adaptec Storage Manager. For more information, refer to the *Adaptec RAID Controller Command Line Interface User's Guide* and the *Adaptec Storage Manager User's Guide*.

**Note:** In some instances, RAID 10 and RAID 50 arrays *may* survive multiple disk drive failures, depending on which disk drives fail.

### Failed Drive in maxCache Pool

Because Solid State Drives (SSD) in the maxCache pool are used just for caching, not permanent storage, no data recovery or rebuilding is necessary. Once you identify the failed SSD, for example, by using *Adaptec Storage Manager's* rapid fault isolation feature, replace the failed SSD with a new one (see [page 52](#)), then add the SSD to the maxCache pool following the instructions on [page 109](#) or by using *Adaptec Storage Manager*.

## Resetting the Controller

This section explains how to reset, or *Mode 0 flash*, your Adaptec RAID controller. You may want to do this if the controller becomes inoperable, or if a firmware upgrade is unsuccessful.

**Note:** Mode 0 flash is supported on Adaptec Series 2 and Adaptec Series 5 controllers only. Adaptec Series 6 controllers support HDA mode flash. For information about HDA mode, see the Readme on the installation DVD or contact your support representative. To locate the HDA mode jumper on Series 6 controller boards, see the illustrations in [Chapter 3](#).

To reset your Adaptec RAID controller:

- 1 Download the firmware version currently installed on your controller from [www.adaptec.com](http://www.adaptec.com).
- 2 Extract the down-loaded files to a folder on your local hard drive (for example, C:\Download\Drivers).

- 3 Copy the file AFU.exe (from the Adaptec Installation DVD) and the firmware image files (typically \*.ufi) to a bootable DOS floppy disk, USB flash drive, or writable CD-ROM.

**Note:** Due to space limitations with floppy disks, you may need to create multiple floppy disks for each firmware image.

- 4 Power off your computer, disconnect the power cord, then open the cabinet following the manufacturer's instructions.
- 5 Disconnect all cables from the controller, then attach a shorting jumper to the Mode 0 flash connector.

**Note:** To locate the Mode 0 flash connector on your Adaptec RAID controller, see the figures in *About Your RAID Controller* on page 17.

- 6 Reconnect the power cord, power on your computer, then boot to the drive containing the AFU.exe file (see [Step 3](#)).

- 7 At the prompt, type `<drive-letter>:\afu update /c x`

where `drive-letter` is the drive identifier (a for a floppy drive, for instance) and `x` is the controller number.

**Note:** You will be prompted to insert other disks, as needed.

- 8 When the flash is complete, power off your computer, disconnect the power cord, then remove the jumper.
  - 9 Close the computer cabinet, reconnect the power cord, then power on your computer. The controller should boot correctly.
-



# Introduction to SAS



**In this appendix...**

- Terminology Used in This Chapter ..... 89
- What is SAS? ..... 89
- How Do SAS Devices Communicate? ..... 90
- What’s a Phy? ..... 90
- What’s a SAS Port?..... 91
- What’s a SAS Address?..... 91
- What’s a SAS Connector? ..... 91
- What do SAS Cables Look Like? ..... 91
- How are Disk Drives Identified in SAS? ..... 92
- What are the SAS Connection Options? ..... 92
- How is SAS Different from Parallel SCSI?..... 94

This section provides a basic overview of the main features of SAS, introduces some common SAS terms, and explains how SAS differs from parallel SCSI.

**Note:** For technical articles and tutorials about SAS, refer to the SCSI Trade Association (STA™) Web site at [www.scsita.org](http://www.scsita.org).

## Terminology Used in This Chapter

For convenience, SAS HBAs and SAS RAID controllers are referred to generically in this chapter as *SAS cards*. HBAs, RAID controllers, disk drives, and external disk drive enclosures are referred to as *end devices* and expanders are referred to as *expander devices*.

For convenience, this chapter refers to end devices and expander devices collectively as *SAS devices*.

## What is SAS?

Legacy parallel SCSI is an interface that lets devices such as computers and disk drives communicate with each other. Parallel SCSI moves multiple bits of data *in parallel* (at the same time), using the SCSI command set.

SAS is an evolution of parallel SCSI to a point-to-point serial interface. SAS also uses the SCSI command set, but moves multiple bits of data one at a time. SAS links end devices through direct-attach connections, or through expander devices.

SAS cards can typically support up to 128 end devices and can communicate with both SAS and SATA devices. (You can add 128 end devices—or even more—with the use of SAS expanders. See [page 93](#).)

**Note:** Although you can use both SAS and SATA disk drives in the same SAS *domain* (see [page 93](#)), we recommend that you not combine SAS and SATA disk drives within the same array or logical drive. The difference in performance between the two types of disk drives may adversely affect the performance of the array.

Data can move in both directions simultaneously across a SAS connection (called a *link*—see [page 90](#)). Link speed is 300 MB/sec in half-duplex mode. Therefore, a SAS card with eight links has a bandwidth of 2400 MB/sec.

Although they share the SCSI command set, SAS is conceptually different from parallel SCSI physically, and has its own types of connectors, cables, connection options, and terminology, as described in the rest of this chapter.

To compare SAS to parallel SCSI, see [How is SAS Different from Parallel SCSI? on page 94](#).

## How Do SAS Devices Communicate?

SAS devices communicate with each other through links. A *link* is a physical connection between two phys.

As shown in the following figure, SAS devices contain ports (see [page 91](#)), ports contain *phys*, and each phy contains one transmitter and one receiver—one *transceiver*. A phy can belong to one port only.

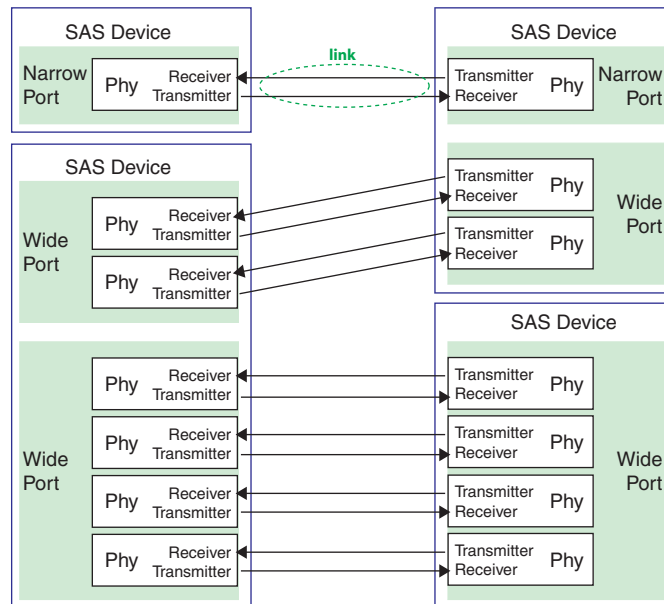

## What's a Phy?

Phys are part of the physical communication connection between SAS devices. Each phy contains a transceiver that sends data back and forth between SAS devices.

When a connection is formed between two end devices, a link is established from a phy in one port to a phy in the other port. As shown in the figure above, a wide port can support multiple independent links simultaneously.

Phys are internal, within SAS connectors (see [page 91](#)).

SAS cables physically connect one or more phys on one SAS device to one or more phys on another SAS device.

## What's a SAS Port?

**Note:** Because the physical link between SAS devices is from phy to phy, rather than port to port, a “port” is more of a virtual concept, different from what is normally considered a port on other types of RAID controllers and storage devices.

A *port* is one or more phys. A *narrow port* contains one phy. A *wide port* typically contains four phys.

Each port has its own unique SAS address (see [page 92](#)), and all the phys in a port share that same SAS address.

SAS card port options vary. A SAS card with four phys could be configured with one wide port, with two wide ports that comprise two phys, or with four narrow ports each containing one phy. (A wide port with four phys is referred to as a *4-wide* or *4x* port.)

## What's a SAS Address?

Each SAS port is identified with a unique SAS address, which is shared by all phys on that port.

For example, a SAS disk drive might have two narrow ports. Each port has one unique SAS address. The single phy in each port uses its port's SAS address.

In another example, a SAS device might have one 4-wide port. That port has one SAS address, which is shared by all four phys in the port.

Unlike SCSI devices and SCSI IDs, SAS devices self-configure their SAS addresses. User intervention is not required to set SAS addresses, and SAS addresses cannot be modified.

## What's a SAS Connector?

A SAS or mini-SAS connector is the physical plug or receptacle that you see on a SAS device. It's what you plug a SAS cable into, or the end of the SAS cable that's being plugged in. (See [Cables on page 42](#).)

A connector is what forms physical links between phys. Some SAS connectors can support multiple links. The number of links a SAS connector can support is referred to as its *width*. *Narrow* connectors support a single link; *wide* connectors supports more than 1 link.

A single SAS device may have one or more connectors. A single SAS connector may help form links between more than two SAS devices. (For instance, as shown in the figure on [page 50](#), the 4-wide internal SAS connector forms links with four independent disk drives.)

## What do SAS Cables Look Like?

Internal standard SAS cables are narrower than internal parallel SCSI cables. The connectors vary in size depending on the number of links they support, from single link connectors to 4-wide (or larger) connectors. Internal fan-out cables let you attach four disk drives to a single 4-wide connector.

Mini-SAS connectors support both internal and external SAS connections. The mini-SAS connectors are smaller than the standard SAS internal and external connectors. Mini-SAS connectors support single and multilinks with the ability to scale to future speed needs.

For examples of some internal SAS/mini-SAS cables and an external SAS/mini-SAS cables, see [Cables on page 42](#).

## How are Disk Drives Identified in SAS?

In the BIOS and in the management utilities (see [Identifying Disk Drives on page 114](#)), disk drives are identified in the following formats:

- CNX:DevY = Device Y is attached to Connector X (see [Direct-attach Connections](#) below for more information)
- BoxX:SlotX = Enclosure X is attached to a disk drive in Slot X (see [Backplane Connections](#) below for more information)
- ExpX:PhyX = Expander X is attached to Phy X (see [SAS Expander Connections](#) below for more information)

where X is the count number.

**Note:** Devices other than disk drives (CDROM, tape drives, etc...) are listed in order after your system disk drives.

In parallel SCSI, XX is the disk drive's channel number, YY is the target number, and ZZ is the logical unit number (LUN).

## What are the SAS Connection Options?

You can connect end devices to each other through direct cable connections and through backplane connections. When you use one or more expander devices (see [page 93](#)), you can create large configurations.

### Direct-attach Connections

In a direct-attach connection, SAS or SATA disk drives are connected directly to a SAS card with SAS or mini-SAS cables. One disk drive is attached to one SAS/mini-SAS connector with one SAS/mini-SAS cable (or multiple disk drives are attached to one SAS/mini-SAS connector with one fan-out cable). The figure on [page 50](#) shows an example of direct-attach connections.

The number of direct-attached disk drives is limited to the number of *phys* supported by the SAS card. (Note that there may be multiple *phys* within a single connector. See [page 93](#).)

### Backplane Connections

In a backplane connection, disk drives and SAS cards are attached to and communicate with each other through a system backplane.

There are two types of backplane connections, *passive* and *active*. When connecting to either backplane, it's important to properly connect your disk drive LEDs in order to identify disk drive conditions. See [About Your RAID Controller on page 17](#) for your RAID controller Activity LED connections and locations.

Once you have connected to a backplane, use Adaptec Storage Manager to manage your disk drives. For more information, refer to the *Adaptec Storage Manager User's Guide* on the Adaptec Installation DVD.

The number of end devices is limited to the number of slots available on the backplane. For example, the Adaptec S50 enclosure, which contains an expander, is a backplane connection that supports up to 12 SAS or SATA disk drives.

Some backplanes support daisy-chain expansion to other backplanes. For example, you can daisy-chain (connect one to the next) up to nine Adaptec S50 enclosures to a single SAS card in a host system.

## SAS Expander Connections

A SAS expander device literally expands the number of end devices that you can connect together. Expander devices, typically embedded into a system backplane (see [page 92](#)), support large configurations of SAS end devices, including SAS cards and SAS and SATA disk drives. With expander devices, you can build large and complex storage topologies.

There are two types of SAS expanders: *fanout expanders* and *edge expanders*. Each performs a different role in a storage system. (For more information about how SAS expanders work, refer to the STA Web site at [www.scsita.org](http://www.scsita.org).)

You can connect up to 128 SAS ports to an edge expander. (A single edge expander can therefore support up to 128 SAS addresses.)

You can connect up to 128 edge expanders to a fanout expander.

You can use only one fanout expander in any single SAS *domain* (a topology of SAS—and possibly SATA—end devices and expander devices). A single SAS domain can therefore comprise up to 16,384 SAS ports (and therefore up to 16,384 SAS addresses including the fanout expander).

The next figure illustrates (in very basic terms) a SAS domain and shows how SAS cards, SAS and SATA disk drives, and expander devices can fit together in a large data storage topology.

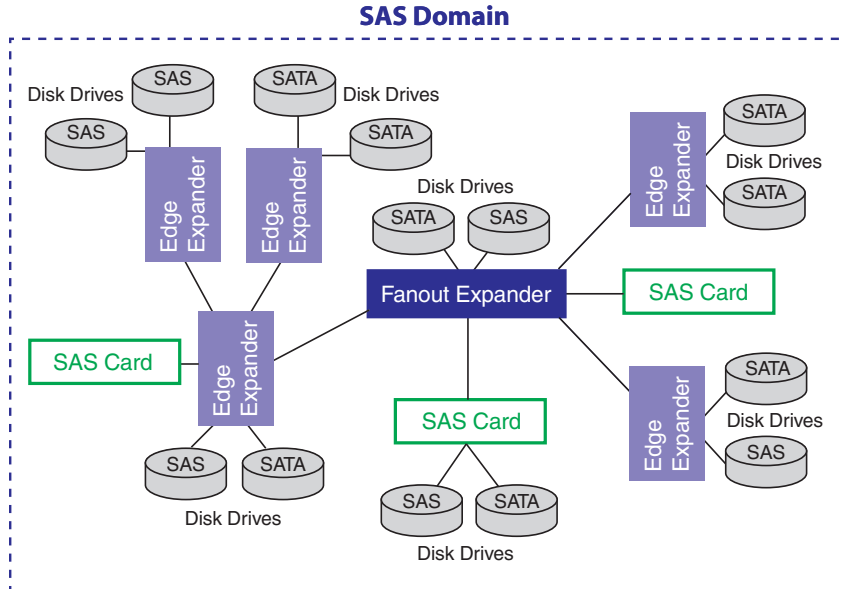

## How is SAS Different from Parallel SCSI?

In summary, although SAS and parallel SCSI both use the SCSI command set, how they move data from one place to another is very different. To support point-to-point *serial* data transport, SAS introduces new types of connectors, cables, connection options, and terminology.

Generally speaking, SAS is faster and more flexible than parallel SCSI, and provides more options for building your storage space. SAS lets you mix SAS and SATA disk drives together, and lets you connect many, *many* more devices.

This table describes many of the main differences between the two interfaces.

Parallel SCSI	Serial Attached SCSI
Parallel interface	Serial interface
Maximum speed 320 MB/sec shared by all devices on the bus	Maximum speed 300 MB/sec per phy when in half-duplex mode
Supports SCSI devices only	Supports SATA and SAS disk drives simultaneously
Up to 16 devices per SCSI channel	More than 100 disk drives per SAS card, using an expander (see <a href="#">page 93</a> ) or 50 SATAII disk drives.
Supports single-port devices only	Supports single- and dual-port devices
Uses SCSI IDs to differentiate between devices connected to the same adapter	Uses unique SAS addresses to differentiate between devices
User intervention required to set SCSI IDs	SAS addresses self-configured by SAS devices
Requires bus termination	Requires no bus termination
Standard SCSI connectors	SAS connectors (see <a href="#">page 42</a> )

# Understanding RAID



## In this appendix...

Understanding Drive Segments.....	96
Non-redundant Arrays (RAID 0).....	96
RAID 1 Arrays.....	97
RAID 1 Enhanced Arrays.....	97
RAID 10 Arrays.....	98
RAID 5 Arrays.....	99
RAID 5EE Arrays.....	100
RAID 50 Arrays.....	101
RAID 6 Arrays.....	102
RAID 60 Arrays.....	102
Selecting the Best RAID Level.....	103

When you create arrays (or logical drives), you can assign a RAID level to protect your data.

Each RAID level offers a unique combination of performance and redundancy. RAID levels also vary by the number of disk drives they support.

This appendix describes the RAID levels supported by your Adaptec RAID controller, and provides a basic overview of each to help you select the best level of protection for your data storage.



## Understanding Drive Segments

A *drive segment* is a disk drive or portion of a disk drive that is used to create an array. A disk drive can include both *RAID segments* (segments that are part of an array) and available segments. Each segment can be part of only one logical device at a time. If a disk drive is not part of any logical device, the entire disk is an available segment.

## Non-redundant Arrays (RAID 0)

An array with RAID 0 includes two or more disk drives and provides data *striping*, where data is distributed evenly across the disk drives in equal-sized sections. However, RAID 0 arrays do not maintain redundant data, so they offer *no data protection*.

Compared to an equal-sized group of independent disks, a RAID 0 array provides improved I/O performance.

Drive segment size is limited to the size of the smallest disk drive in the array. For instance, an array with two 250 GB disk drives and two 400 GB disk drives can create a RAID 0 drive segment of 250 GB, for a total of 1000 GB for the volume, as shown in this figure.

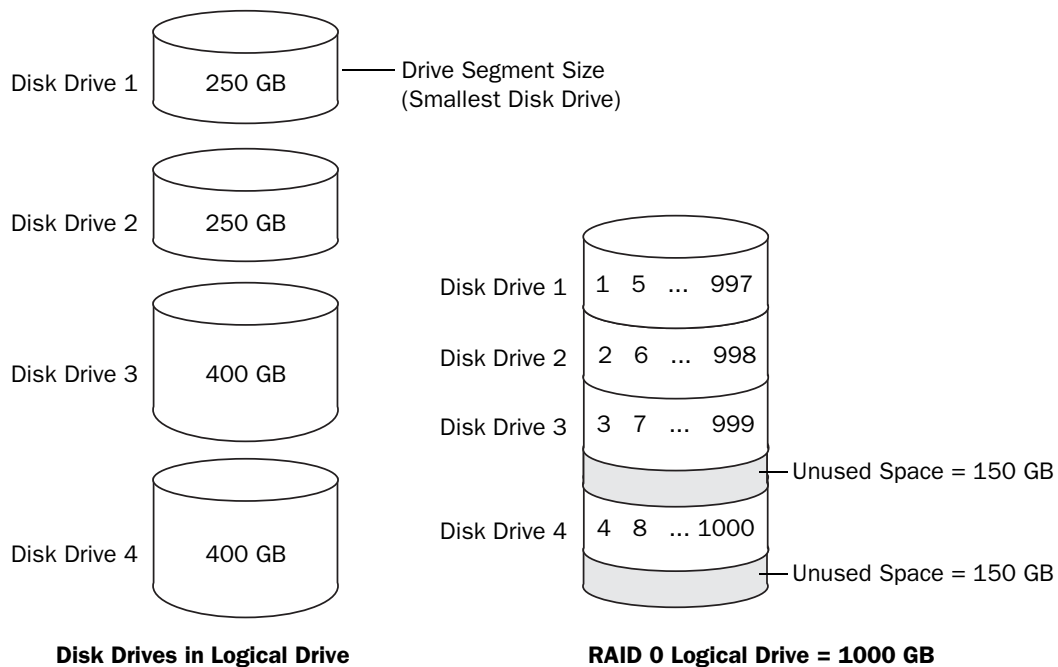

## RAID 1 Arrays

A RAID 1 array is built from two disk drives, where one disk drive is a *mirror* of the other (the same data is stored on each disk drive). Compared to independent disk drives, RAID 1 arrays provide improved performance, with twice the read rate and an equal write rate of single disks. However, capacity is only 50 percent of independent disk drives.

If the RAID 1 array is built from different-sized disk drives, the free space, drive segment size is the size of the smaller disk drive, as shown in this figure.

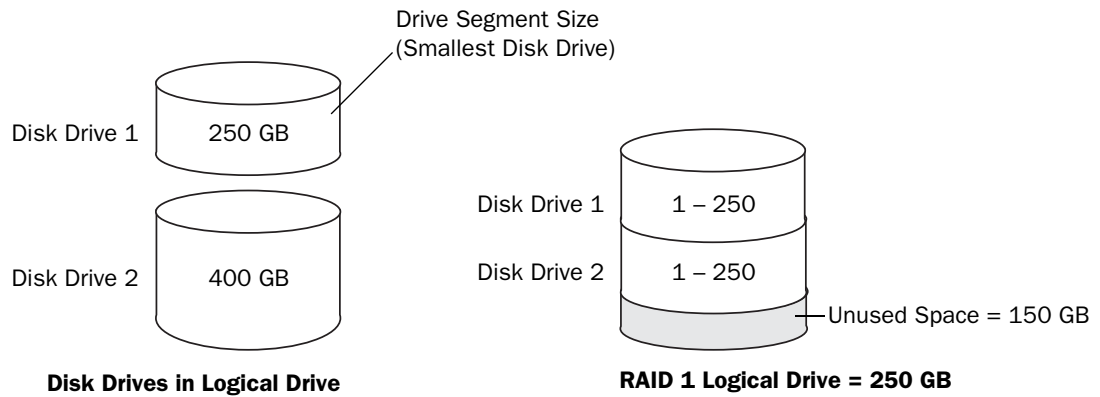

## RAID 1 Enhanced Arrays

A RAID 1 Enhanced (RAID 1E) array—also known as a *striped mirror*—is similar to a RAID 1 array except that data is both mirrored *and* striped, and more disk drives can be included. A RAID 1E array can be built from three or more disk drives.

In this example, the large bold numbers represent the striped data, and the smaller, non-bold numbers represent the mirrored data stripes.

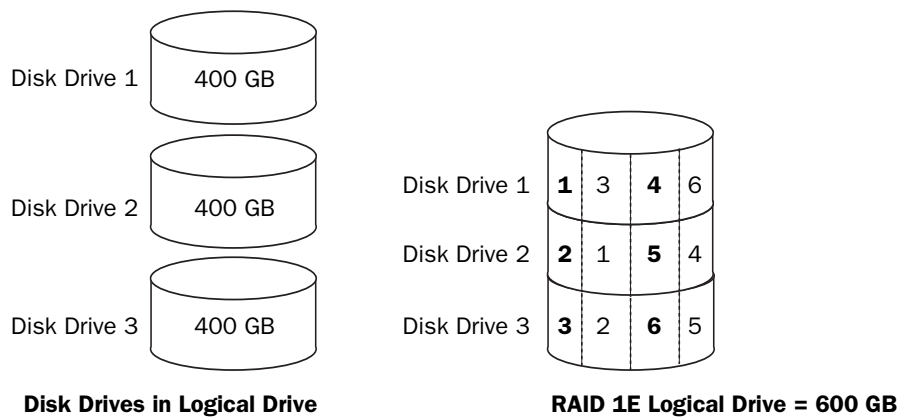

## RAID 10 Arrays

A RAID 10 array is built from two or more equal-sized RAID 1 arrays. Data in a RAID 10 array is both striped and mirrored. Mirroring provides data protection, and striping improves performance.

Drive segment size is limited to the size of the smallest disk drive in the array. For instance, an array with two 250 GB disk drives and two 400 GB disk drives can create two mirrored drive segments of 250 GB, for a total of 500 GB for the array, as shown in this figure.

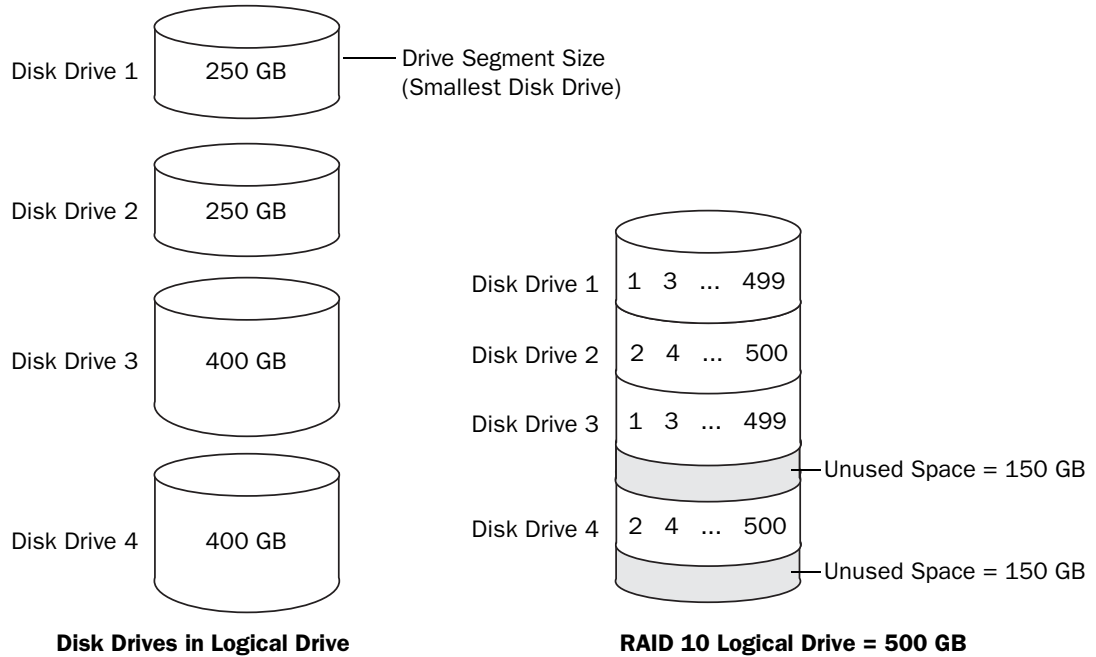

## RAID 5 Arrays

A RAID 5 array is built from a minimum of three disk drives, and uses data striping and *parity* data to provide redundancy. Parity data provides data protection, and striping improves performance.

Parity data is an error-correcting redundancy that's used to re-create data if a disk drive fails. In RAID 5 arrays, parity data (represented by Ps in the next figure) is striped evenly across the disk drives with the stored data.

Drive segment size is limited to the size of the smallest disk drive in the array. For instance, an array with two 250 GB disk drives and two 400 GB disk drives can contain 750 GB of stored data and 250 GB of parity data, as shown in this figure.

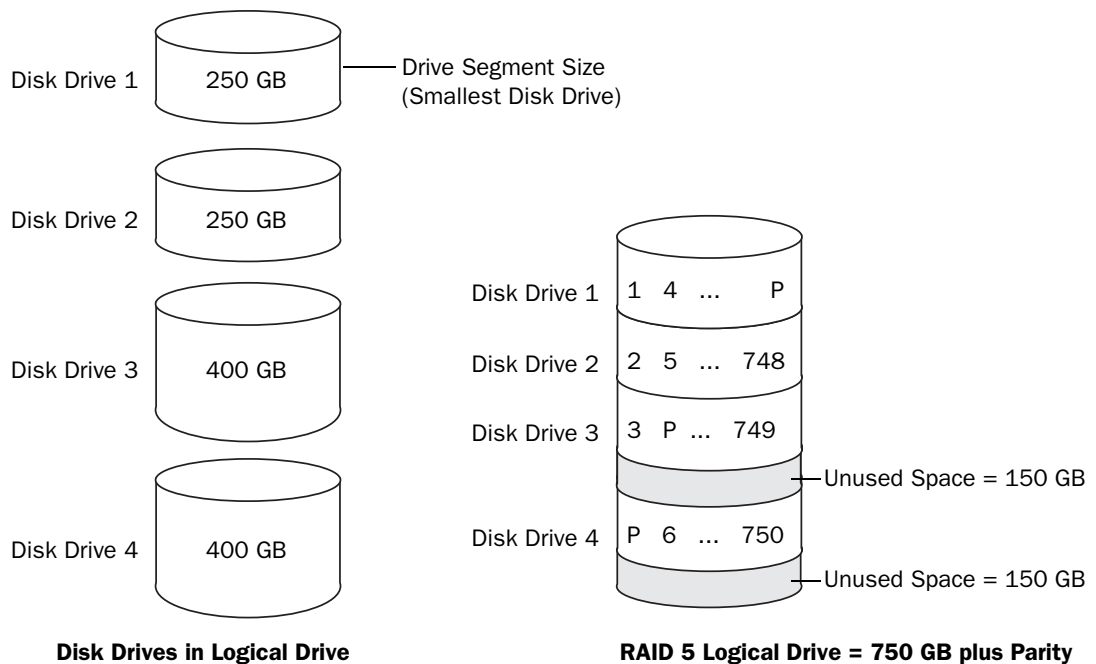

## RAID 5EE Arrays

A RAID 5EE array—also known as a *hot space*—is similar to a RAID 5 array except that it includes a *distributed spare* drive and must be built from a minimum of four disk drives.

Unlike a hot spare, a distributed spare is striped evenly across the disk drives with the stored data and parity data, and can't be shared with other logical disk drives. A distributed spare improves the speed at which the array is rebuilt following a disk drive failure.

A RAID 5EE array protects your data and increases read and write speeds. However, capacity is reduced by two disk drives' worth of space, which is for parity data and spare data.

In this figure, S represents the distributed spare, P represents the distributed parity data.

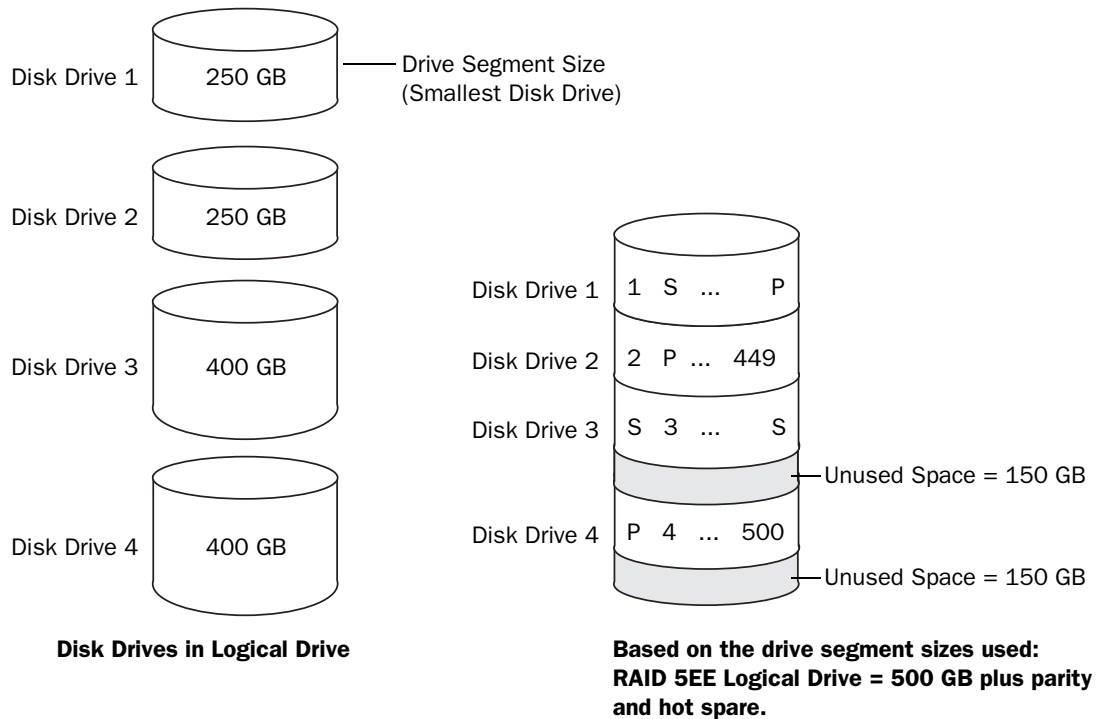

## RAID 50 Arrays

A RAID 50 array is built from six to forty-eight disk drives configured as two or more RAID 5 arrays, and stripes stored data and parity data across all disk drives in both RAID 5 arrays. (For more information, see [RAID 5 Arrays on page 99](#).)

The parity data provides data protection, and striping improves performance. RAID 50 arrays also provide high data transfer speeds.

Drive segment size is limited to the size of the smallest disk drive in the array. For example, three 250 GB disk drives and three 400 GB disk drives comprise two equal-sized RAID 5 arrays with 500 GB of stored data and 250 GB of parity data. The RAID 50 array can therefore contain 1000 GB (2 x 500 GB) of stored data and 500 GB of parity data.

In this figure, P represents the distributed parity data.

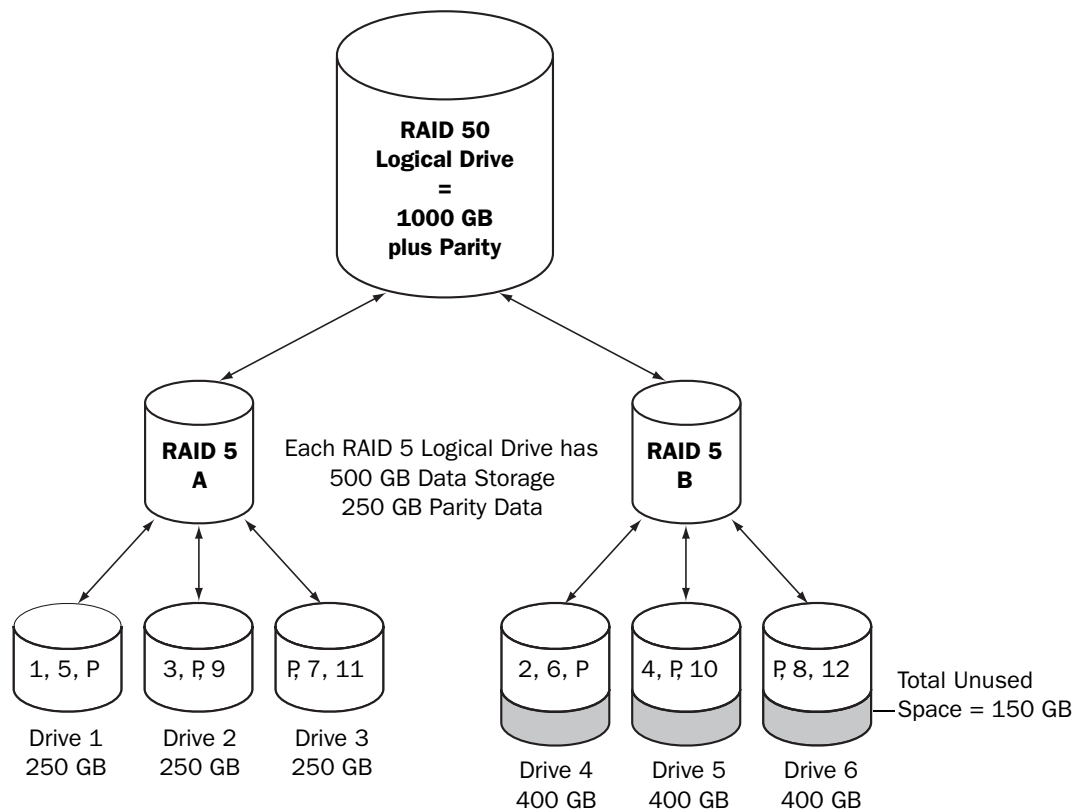

## RAID 6 Arrays

A RAID 6 array—also known as dual drive failure protection—is similar to a RAID 5 array because it uses data striping and parity data to provide redundancy. However, RAID 6 arrays include *two* independent sets of parity data instead of one. Both sets of parity data are striped separately across all disk drives in the array.

RAID 6 arrays provide extra protection for your data because they can recover from two simultaneous disk drive failures. However, the extra parity calculation slows performance (compared to RAID 5 arrays).

RAID 6 arrays must be built from at least four disk drives. Maximum stripe size depends on the number of disk drives in the array.

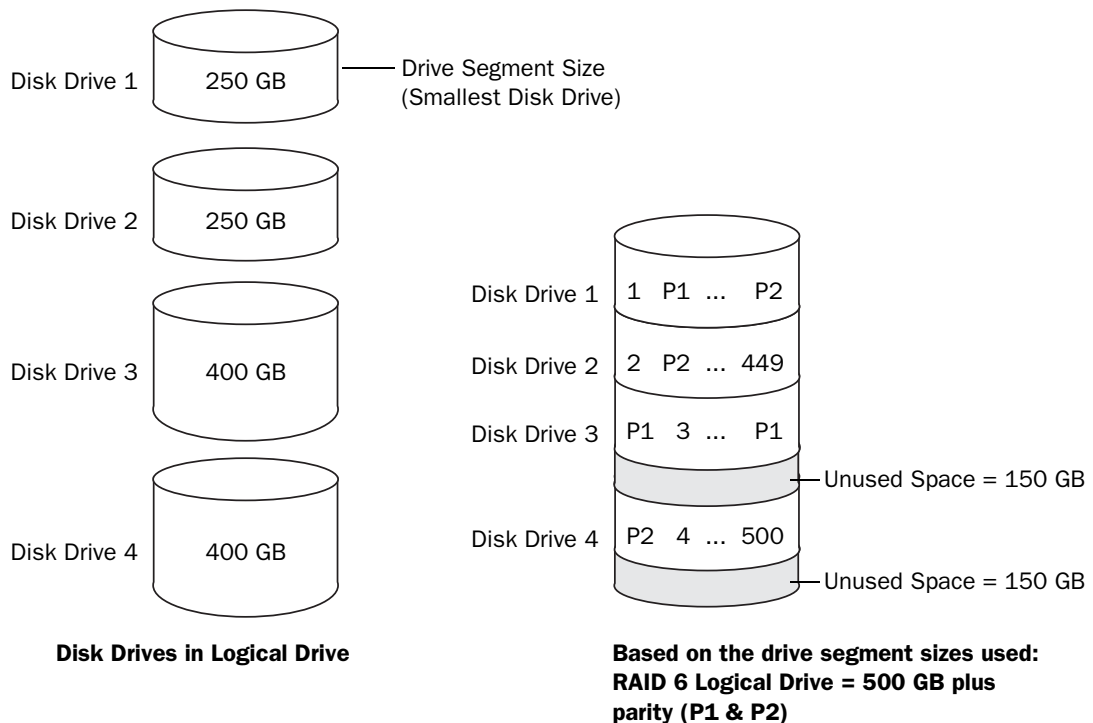

## RAID 60 Arrays

Similar to a RAID 50 array (see [page 101](#)), a RAID 60 array—also known as dual drive failure protection—is built from eight disk drives configured as two or more RAID 6 arrays, and stripes stored data and two sets of parity data across all disk drives in both RAID 6 arrays.

Two sets of parity data provide enhanced data protection, and striping improves performance. RAID 60 arrays also provide high data transfer speeds.

## Selecting the Best RAID Level

Use this table to select the RAID levels that are most appropriate for the logical drives on your storage space, based on the number of available disk drives and your requirements for performance and reliability.

RAID Level	Redundancy	Disk Drive Usage	Read Performance	Write Performance	Built-in Hot Spare	Minimum Disk Drives
RAID 0	No	100%	◆◆◆	◆◆◆	No	2
RAID 1	Yes	50%	◆◆	◆◆	No	2
RAID 1E	Yes	50%	◆◆	◆◆	No	3
RAID 10	Yes	50%	◆◆	◆◆	No	4
RAID 5	Yes	67 – 94%	◆◆◆	◆	No	3
RAID 5EE	Yes	50 – 88%	◆◆◆	◆	Yes	4
RAID 50	Yes	67 – 94%	◆◆◆	◆	No	6
RAID 6	Yes	50 – 88%	◆◆	◆	No	4
RAID 60	Yes	50 – 88%	◆◆	◆	No	8

Disk drive usage, read performance, and write performance depend on the number of drives in the logical drive. In general, the more drives, the better the performance.



# Using the Adaptec RAID Configuration Utility



## In this appendix...

Introduction to the ARC Utility .....	105
Running the ARC Utility.....	105
Using the ACU to Create and Manage Arrays .....	105
Using the ACU to Create and Manage JBODs.....	109
Using the ACU to Manage the maxCache Pool .....	109
Using SerialSelect to Modify Controller Settings .....	110
Formatting and Verifying Disk Drives .....	113
Locating Disk Drives .....	113
Identifying Disk Drives .....	114
Viewing the Event Log .....	114

The Adaptec RAID Configuration (ARC) utility is a BIOS-based utility that you can use to create arrays and manage controllers, disk drives and other devices.

**Note:** We recommend that only advanced users familiar with working in a computer BIOS use the ARC utility tools. For more information, see [Managing Your Storage Space on page 79](#).

## Introduction to the ARC Utility

The ARC utility comprises these tools:

- **The Array Configuration Utility (ACU)**—For creating and managing arrays, and initializing and rescanning disk drives (see [page 105](#)).
- **SerialSelect**—For modifying your controller and disk drive settings (see [page 110](#)).
- **Disk Utilities**—For formatting or verifying disk drives (see [page 113](#)).

## Running the ARC Utility

If your Adaptec controller is connected to a RAID enclosure, power on your enclosure (or enclosures) before you power on your computer.

Start or restart your computer. When prompted, press Ctrl+A.

During boot up, if your system has insufficient memory this message displays:

“Adaptec RAID Configuration Utility will load after, system initialization. Please wait... Or press <Enter> Key to attempt loading the utility forcibly [Generally, not recommended]”

**Note:** The first time you power on your computer after you install a new controller, the BIOS may display a configuration that doesn't match your system's configuration. This is normal.

### Navigating the ARC Utility

All the tools within the ARC utility are menu-based and instructions for completing tasks appear on-screen. Menus can be navigated using the arrows, Enter, Esc, and other keys on your keyboard.

## Using the ACU to Create and Manage Arrays

To open the ACU, start the ARC utility (see [page 105](#)). If you have more than one controller, select your controller, then press Enter. Select **Array Configuration Utility**, then press Enter.

Follow the on-screen instructions to create and manage arrays, and initialize, rescan, and erase disk drives.

### Creating a New Array

To begin creating an array, select **Create Arrays** from the main ACU menu.

Only disk drives that can be used in a new array are available for selection. (Disk drives must be initialized before they can be used in an array. See [Initializing Disk Drives on page 108](#) for more information.)

Use the Array Properties menu to modify the array's RAID level, size, name, stripe size, cache settings, and maxCache settings.

**Note:** For more information about RAID levels and using disk drives to create arrays, see [Choosing a RAID Level on page 41](#). For more information about maxCache, see [Modifying Cache Settings on page 107](#); see also [Using the ACU to Manage the maxCache Pool on page 109](#).

## Managing Existing Arrays

To view or modify existing arrays, select **Manage Arrays** from the main ACU menu.

From the Manage Arrays menu, you can:

- View the properties of an array.
  - Note:** Failed drives are displayed in a different text color.
- Make an array bootable (see [Creating Bootable Arrays on page 106](#)).
- Assign or remove hot spares.
- Modify power management settings.
- Change the cache settings for an array.
- Delete an array.

 **Caution:** Before deleting an array, back up the data to avoid permanently losing it.

### Creating Bootable Arrays

**Note:** You may need to change the system BIOS to modify the boot order. For more information, refer to your computer documentation.

The controller always uses the lowest numbered array as its bootable array.

To make an array bootable:

- 1 Select **Manage Arrays** from the main ACU menu.
- 2 Select the array that you want to make bootable, then press **Ctrl+B**.

**Note:** You cannot make an array bootable while it's building, verifying, or rebuilding.

The array's number changes to Array 00, which makes this array the controller's boot array.

- 3 Restart your computer.

### Modifying Power Management Settings

Power management settings switch the array to low power state when it is inactive for a specific time.

To modify power management settings:

- 1 Select **Manage Arrays** from the main ACU menu.
- 2 Select the array, then press **Ctrl+W**.

In the power management console, enter these details:

Option	Description
Power Management	When enabled, switches the array to low power state, when the array/drive is inactive.
Slow Down Drive After	The duration of inactive state of the array/drive after which it is slowed down to low power mode. This is an optional setting.

**Note:** The disk drive should support low power mode.

Option	Description
Power Off Drive After	The duration of inactive state of the array/drive after which it is powered off. This is an optional setting.  <b>Note:</b> Power Off Drive After duration should be greater than Slow Down Drive After Duration.
Verify Drive After	The regular time interval at which the system performs a health check of the array/drive.

### Modifying Cache Settings

You can modify the read and write cache settings for an array. You can also modify the maxCache settings. Adaptec maxCache uses the compatible Solid State Drives (SSDs) in your system as a fast read cache pool to improve performance in read-intensive applications.

**Note:** maxCache Read Caching is supported on Adaptec Series Q controllers only. For more information about maxCache, see [Using the ACU to Manage the maxCache Pool on page 109](#).

To modify the cache settings for an array:

- 1 Select **Manage Arrays** from the main ACU menu.
- 2 Select the array, then press **Ctrl+C**.  
The Modify Cache Settings window opens.
- 3 Enable or disable read caching.
- 4 Press **Tab**.
- 5 Enable or disable write caching:
  - Select Enable always for “write-back” caching
  - Select Enable with ZMM if your controller has battery backup or a zero-maintenance cache protection module
  - Select Disable for “write-through” caching
- 6 Press **Tab**.
- 7 Select the maxCache Read Cache setting (Enable/Disable).
- 8 Press **Tab**.
- 9 Press **Enter** to accept the values.

## Initializing Disk Drives

If a disk drive appears grayed-out (unavailable for use in a new array), it may need to be initialized.

To begin initializing a disk drive, select **Initialize Drives** from the main ACU menu. You can initialize one drive or multiple drives. If an error occurs during initialization, the message “Initializing drives...FAILED x of n” is displayed. Press **Enter** to see a list of drives that failed to initialize. Press **Esc** to continue.

 **Caution:** Do not initialize a disk drive that is part of an array. Initializing a disk drive that’s part of an array may make the array unusable.  
Back up all data from your disk drive before you initialize it.

## Rescanning Disk Drives

To begin rescanning a disk drive, select **Rescan Drives** from the main ACU menu.

## Secure Erasing Disk Drives

When you perform a secure erase on a disk drive, all data on that disk drive is completely and irretrievably eradicated. Secure erase performs three distinct writing passes to the disk drive being erased—it does not just write zeros.

Performing a secure erase takes up to six times longer than clearing (or zeroing) a disk drive. You may want to perform a secure erase only on disk drives that contain confidential or classified information.

**Note:** To erase (or zero) a disk drive with non-classified information, you may choose to *format* it (see [page 113](#)) instead, or *clear* it using Adaptec Storage Manager—both options take much less time than the secure erase option.

To begin a secure erase, select **Secure Erase** from the main ACU menu, then select **Y** (yes). To return to the main ACU menu once the secure erase has begun, press **Esc**.

The selected disk drive(s) cannot be used until the erase is complete.

### Stopping a Secure Erase

To stop a secure erase in progress:

- 1 In the main ACU window, select **Secure Erase**.
- 2 Select the disk drive being secure erased, then press **Ctrl+Q**.

The secure erase stops and the ACU returns to its main window.

## Managing Global Hot Spares

A hot spare is a disk drive that automatically replaces any failed drive in a logical drive. A *global* hot spare is not assigned to a specific logical drive. It protects any logical drive on the controller (except RAID 0 logical drives). You can create and delete global hot spares even if no arrays exist.

To create and delete global hot spares:

- 1 Select **Global Hotspares** from the main ACU menu.

The Global Hotspare Management window opens.

- 2 Using the arrow keys, select a drive from the list. Existing hot spares are highlighted.
- 3 Press **Ins** to create a new global hot spare. Press **Del** to delete a hot spare.
- 4 Press **Enter** to save your changes and return to the main menu.

## Using the ACU to Create and Manage JBODs

Start the ARC utility (see [page 105](#)). If you have more than one controller, select your controller, then press **Enter**. Select **Array Configuration Utility**, then press **Enter**.

Follow the on-screen instructions to create and manage JBODs.

### Creating a New JBOD

A JBOD disk appears as a physical disk drive to the operating system. A JBOD disk is not redundant and not bootable.

To begin creating a JBOD, select **Create JBOD** from the main ACU menu. All the supported disk drives are displayed. Select a disk drive and **Enter**.

### Managing Existing JBODs

To delete a JBOD or morph a JBOD into a simple volume, select **Manage JBODs** from the main ACU menu.

From the Manage JBODs menu, you can:

- Morph a JBOD into a simple volume.
- Delete a JBOD

**Note:** When you delete a JBOD, you lose all data on that disk.

### Converting a JBOD Into a Simple Volume

You can convert any JBOD into a simple volume.

- 1 Select **Manage JBODs** from the main ACU menu.
- 2 Select the JBOD that you want to morph into a simple volume and press **Ctrl+V**.

## Using the ACU to Manage the maxCache Pool

Adaptec maxCache uses the compatible Solid State Drives (SSDs) in your system as fast cache memory for read-intensive operations. Before you can enable maxCache read caching on a logical device (see [page 107](#)), you must assign at least one SSD to the maxCache pool.

**Note:** You can configure the maxCache pool only if you have one or more compatible Solid State Drives installed on the RAID controllers in your system. For a list of maxCache-compatible SSDs, refer to the Adaptec Web site at [www.adaptec.com/compatibility](http://www.adaptec.com/compatibility).

To add a SSD to the maxCache pool or to remove a SSD from the pool:

- 1 Start the ARC utility (see [page 105](#)). If you have more than one controller, select your controller, then press **Enter**. Select **Array Configuration Utility**, then press **Enter**.

- 2 Select **Manage MaxCache Pool** from the ACU main menu.

All supported SSDs are displayed.

**Note:** Uninitialized SSDs may not appear in the list; see [page 108](#) for more information about initializing drives.

- 3 Using the arrow keys, select a SSD from the list.
- 4 Press **Ins** to add the SSD to the maxCache pool.
- 5 To remove a SSD from the pool, press the right arrow to switch windows, use the arrow keys to select a SSD, then press **Del**.
- 6 Press **Enter** to save your changes and return to the main menu.

## Using SerialSelect to Modify Controller Settings

The *SerialSelect* utility is a tool for modifying the settings of your controller and the disk drives connected to it.

### Opening SerialSelect

To open *SerialSelect*, start the ARC utility (see [page 105](#)), select *SerialSelect*, then press **Enter**.

Follow the on-screen instructions to modify the settings of your controller and connected disk drives as required.

### Applying Changes and Exiting

- 1 To exit *SerialSelect*, press **Esc** until you are prompted to exit.

If you modified any settings, you are prompted to save the changes before you exit.

- 2 Select **Yes** to exit, then press any key to restart your computer.

Any changes you made take effect after the computer restarts.

### Modifying Your Controller's Configuration

**Note:** Default controller settings are suitable for most computers. We recommend that you *do not* change the default setting.

To modify your controller's basic settings, select **Controller Configuration** from the main *SerialSelect* menu.

To modify your controller's power management settings, select **Advanced Configuration**.

To modify your controller's PHY settings, select **PHY Configuration**.

Some options may not be available for your controller.

---

## General Controller Settings

**Note:** Default settings are shown in **bold** type.

Option	Description
Drive's Write Cache	When set to Enable All, write cache is enabled on all disk drives on the controller. (Enabling the write cache overrides any individual drive settings in Adaptec Storage Manager.) When set to Disable All, write cache is not used on the disk drives. When set to Drive Specific, write cache is enabled/disabled on a per-drive basis in Adaptec Storage Manager. <b>Caution</b> —When write cache is enabled, there is a slight possibility of data loss or corruption during a power failure.
Runtime BIOS	When <b>enabled</b> , the controller BIOS allows the controller to act as a bootable device. Disabling the BIOS allows another controller to act as a bootable device.
Automatic Failover	When <b>enabled</b> , the controller automatically rebuilds an array when a failed disk drive is replaced. When disabled, the array must be rebuilt manually.
Array Background Consistency Check	When enabled, the controller constantly verifies a redundant array. Note that there may be a significant performance reduction. Default is <b>disabled</b> .
Array-based BBS Support	When enabled in systems that support BBS, the controller presents attached bootable devices up to the BIOS for boot device selection. This is relevant for logical arrays. Default is <b>disabled</b> .
SATA Native Command Queuing (NCQ)	When <b>enabled</b> , NCQ is enabled. Disable this feature if you want to attach more than 48 SATA II disk drives. Only available with SATA II disk drives.
Physical Drives Display During POST	When enabled, connected disk drives are displayed during system Power On Self Test (POST). Displaying the disk drives adds a few seconds to the overall POST time. Default is <b>disabled</b> .
DVD/CD-ROM Boot Support	When <b>enabled</b> , the system can be booted from a bootable DVD/CD. (This setting is not available on all RAID controller models.)
Removable Media Devices Boot Support	When <b>enabled</b> , removable media devices, such as CD drives, are supported. (This setting is not available on all RAID controller models.)
Alarm Control	When enabled, the alarm sounds. Default is <b>enabled</b> . <b>Note</b> —When the alarm is turned off (disabled), it will remain off after a reboot.
Default Background Task Priority	Sets the default priority for background tasks on the controller (such as logical drive creation) to High, Medium, or Low. Default is <b>Medium</b> . <b>Note</b> —This setting applies to new tasks. It does not affect currently running tasks.
LED Indication Mode	When set to Activity and Fault, the drive activity LEDs blink to indicate I/O activity (randomly depending on I/O load) and fault (steady 1Hz). When set to Fault Only, the drive activity LEDs blink to indicate fault state only. For Series 2 and Series 5 controllers, default is <b>Activity and Fault</b> . For Series 6/6E controllers, default is <b>Fault Only</b> .



Option	Description
Backplane Mode	<ul style="list-style-type: none"> <li>Series 2, Series 5, Series 6 Controllers: When set to Auto, controller automatically detects backplane signal type: I2C or SGPIO. To set the backplane mode explicitly select SGPIO, I2C, or Disabled. Default is <b>Auto</b>.</li> <li>Series 6E/6T Controllers: When set to Default, controller automatically sets the backplane mode to IBPI. To set the backplane mode explicitly, select IBPI, SGPIO, or Disabled. Default is <b>IBPI</b>.</li> </ul> <p><b>Note</b>—With the default IBPI setting, the firmware sends a SGPIO “Backplane_TYPE” signal if it recognizes that a SGPIO Backplane is connected. If any connected SGPIO backplane does not support the “Backplane_TYPE” signal, or it does not support the IBPI protocol, you can manually set the Backplane Mode to "SGPIO".</p>
Selectable Performance Mode	When set to Dynamic, performance criteria adjusts automatically based on controller usage, RAID level, and disk drive type. When set to OLTP/Db, performance criteria is optimized for transaction-oriented applications, such as data entry and retrieval. When set to Big Block Bypass, DRAM write cache is bypassed based on IO write size; performance criteria is optimized for serving Web pages, file serving, and data retrieval. Default is <b>Dynamic</b> .

### Power Management Settings

**Note:** When power management is disabled, no related options will be displayed.

**Note:** Make sure the operating system driver supports power management.

**Note:** Default settings are shown in **bold** type.

Option	Description
Power Management Settings	When enabled, switches the system to low power state, based on the specified settings.
Time Zone	<p>The time zone of the place in which the system is located. Time specific power management settings are implemented based on the set time zone. By default, it is set to <b>00:00</b>.</p> <p>The valid range for the time zone settings is -12:00 to +12:00.</p>
Stay Awake Start	<p>The time from which the system should operate in the full power mode, irrespective of other power management settings, daily. By default it is set to <b>00:00</b>.</p> <p>The valid range is 00:00 to 23:59.</p>
Stay Awake End	<p>The time until which the system should operate in the full power mode, irrespective of other power management settings, daily. By default it is set to <b>00:00</b>.</p> <p>The valid range is 00:00 to 23:59.</p>
Spin Up Limit (Internal)	The number of internal drives to be spun up at any given moment. By default it is set to <b>0</b> . In the default setting, all the internal drives will spin up.
Spin Up Limit (External)	The number of external drives to be spun up at any given moment. By default it is set to <b>0</b> . In the default setting, all the external drives will spin up.

## PHY Settings

Option	Description
PHY Rate	The data transfer rate between the controller and devices. The default setting is <b>Auto</b> , which allows the SAS card to adjust the data transfer rate, as needed. For low-port 5-series RAID controllers (5085, 5405), you can set the PHY rate to 1.5Gb/second or 3.0Gb/second (the maximum rate).
CRC Checking	When enabled, determines whether the controller verifies the accuracy of data transfer on the serial bus. Default setting is <b>Yes</b> (enabled). Set to No (disabled) <i>only</i> if the controller is connected to a device that does not support CRC Checking.
SAS Address	In a situation where you want each phy on a controller to be in a different SAS domain, this setting specifies a unique world-wide name for each phy. Default is <b>0</b> . <b>Note:</b> This setting is for SAS address conflict resolution only and should otherwise remain at its default value.

## Formatting and Verifying Disk Drives

You can use the disk utilities to low-level format or verify your disk drives. (New disk drives are low-level formatted at the factory and do not need to be low-level formatted again.)

 **Caution:** Before you format a disk drive, back up all data. Formatting destroys all data on a disk drive.

To format or verify a disk drive:

- 1 Start the ARC utility (see [page 105](#)).
- 2 Select the controller you want, then press **Enter**.
- 3 Select **Disk Utilities**.
- 4 Select the disk drive you want, then press **Enter**.
- 5 Select **Format Disk** or **Verify Disk Media**.

## Locating Disk Drives

**Note:** This feature is only available with disk drives that have an activity LED.

You can use the Identify Drive feature to physically locate a disk drive by blinking the LED.

To locate a disk drive:

- 1 Start the ARC utility (see [page 105](#)).
- 2 Select the controller you want, then press **Enter**.
- 3 Select **Disk Utilities**.
- 4 Select the disk drive you want, then press **Enter**.
- 5 Select **Identify Drive**, then press **Enter**.
- 6 When you have finished locating your disk drive, press any key to stop the blinking.

## Identifying Disk Drives

You can identify disk drives by viewing the list of disk drives on your system. Only physical drives that display during POST are shown.

To identify a disk drive:

- 1 Start the ARC utility (see [page 105](#)).
- 2 Select the controller you want, then press **Enter**.
- 3 Select **Disk Utilities**.

The Disk Utilities view will provide you with the following information:

Location	Model	Rev#	Speed	Size
CN1=DEV1 Box0=Slot0 Exp0=phy0	The manufacturer information.	The revision number of the disk drive.	The speed of the disk drive.	The size of the disk drive.

The location information of a disk drive is determined by three types of connections:

- Direct attached drives—The connection is determined by the cable connected to a device, for example CN1 (connector 1) is connected to DEV1 (device 1). For more information, see [Direct-attach Connections on page 92](#).
- Storage Enclosure Processor (SEP) managed devices—The connection is determined by an active backplane. Box0 (enclosure 0) is connected to slot0 (disk drive slot 0 in the enclosure). For more information, see [Backplane Connections on page 92](#).
- Expanders—The connections is determined by an expander. Exp0 (expander 0) is connected to phy0 (phy 0 within a connector). For more information, see [SAS Expander Connections on page 93](#).

**Note:** Devices other than disk drives (CDROM, tape drives, etc...) are listed in order after your system disk drives.

## Viewing the Event Log

The BIOS-based event log records all firmware events, such as configuration changes, array creation, and boot activity.

Some events are not stored indefinitely—the event log is cleared of any non-persistent events each time you restart your computer; additionally, once the log is full, new events overwrite old events.

To view the event log:

- 1 Start the ARC utility (see [page 105](#)).
- 2 Select the controller you want, then press **Enter**.
- 3 When the ARC utility menu appears, then press **Ctrl+P**.
- 4 Select **Controller Log Information**, then press **Enter**.

The current event log opens.

# Using the Adaptec Flash Utility



## In this appendix...

System Requirements .....	116
Before You Begin .....	116
Running the Menu-based AFU.....	117
Running the AFU from the Command Line.....	118
Updating the Flash Using the AFU Command Line .....	121

This chapter describes how to use the Adaptec Flash Utility (AFU), a text-based DOS utility that you can use to update, save, or verify the RAID controller's firmware BIOS and NVRAM.

 **Caution:** Although the AFU contains safeguards to prevent you from accidentally damaging your RAID controller's flash contents, it is still important to use the AFU carefully and correctly to avoid rendering your RAID controller inoperable. We recommend that only advanced users familiar with working in DOS use the AFU. For more information, see [Managing Your Storage Space on page 79](#).

## System Requirements

- DOS version 5.0 or later.

**Note:** You can't run the AFU from a DOS command prompt window under any version of Windows.

- At least 8 MB of extended memory.

### Compatibility Notes

- Supports HIMEM.SYS; compatible with other DOS drivers running under HIMEM.SYS (for example, SMARTDRV.SYS and SETVER.SYS).
- *Does not* support DOS extenders installed in memory, such as EMM386.SYS and DOS4GW.

## Before You Begin

- 1 Obtain the firmware (see the following section).
- 2 Create firmware disks (see [page 117](#)).

There are two ways to run the AFU:

- 1 Using the AFU menus (see [page 117](#))
- 2 From the command line (see [page 118](#))

### Obtaining the Firmware

To obtain RAID controller firmware, go to:

- **Adaptec Installation DVD**—Includes the AFU executable (AFU.exe) and a separate flash image. The flash image may comprise multiple User Flash Image (UFI) files.
- **Adaptec Web site**—Download a new firmware file to get the most recent version of firmware/BIOS and AFU.

See [www.adaptec.com](http://www.adaptec.com) for more information.

---

## Creating the Firmware Update Disks

To create the firmware update disks:

- 1 Copy these files to empty, formatted floppy disks, a USB flash drive, or a writable CD:

- AFU.exe
- Axxxx01.ufi

where xxx is the model number of your controller.

**Note:** Most controller model numbers have a suffix (for example Adaptec RAID 3405). Check that the .ufi file is the correct file for your controller before copying.

- 2 If using floppy disks, copy each additional Axxxx0x.ufi file to a separate floppy disk. (Some RAID controllers have four UFI files; some have more. Each goes onto its own floppy disk.)
- 3 To use a menu-based AFU, see the following section.

To run the AFU from the command line, see [page 118](#).

## Running the Menu-based AFU

To run the menu-based AFU:

- 1 Shut down your operating system and reboot to DOS from a bootable DOS floppy disk or from a DOS partition on a bootable drive. (You can use a disk drive connected to the controller you are updating.) If your computer isn't set up to boot from the bootable floppy disk, enter the system setup utility and change the setting.
- 2 Insert the firmware update disk (created using the steps above) containing AFU.exe
- 3 At the DOS command prompt, type `AFU` with no arguments.

The AFU's main menu is displayed.

- 4 Select **Select Controllers**, then select the Adaptec RAID controller(s) to be flashed.

To update multiple RAID controllers in the same system, update the boot controller's flash first, restart the computer, then update the flash for the remaining controllers.

- 5 Select **Select an Operation**.
- 6 Choose the operation you want, then follow the on-screen instructions to complete the task:
  - **Update flash image**—Updates all the flash components on a RAID controller with the flash image data from the UFI file.
  - **Save flash image**—Reads the contents of a RAID controller's flash components and saves the data to a UFI file, which you can use to restore a RAID controller's flash if required.
  - **Verify flash image**—Reads the contents of a RAID controller's flash components and compares it to the contents of the specified UFI file.
  - **Display flash information**—Displays version information about a RAID controller's flash components.

- 7 Complete the flash operation and restart your computer before trying to use the RAID controller again. (You can not use your RAID controller while you are updating its flash.)

The AFU processes the selected command, prompts you to insert additional floppy disks as needed, and reports either success or an error message code.

## Running the AFU from the Command Line

**Note:** You can also run a menu-based AFU (see [page 117](#)).

To run the AFU from the command line:

- 1 Shut down your operating system and reboot to DOS from a bootable DOS floppy disk or from a DOS partition on a bootable drive. (You can use a disk connected to the controller you're updating.) If your computer isn't set up to boot from the bootable floppy disk, enter the system setup utility to change the setting.
- 2 Insert the firmware update disk containing AFU.exe
- 3 At the DOS command, type AFU followed by a command (see [page 118](#)) and any switches you want.

**Note:** To find a controller number, type `AFU LIST`, then press **Enter**.

The AFU processes the command, prompts you to insert additional floppy disks as needed, exits, and reports either success or an error message code.

To update a RAID controller's flash using the command line utility ARCCONF, see [page 121](#).

## AFU Commands

This section lists the available AFU commands.

### List

Displays the AFU-supported RAID controllers installed on your computer. Also displays the ID numbers assigned to each controller.

You don't have to restart the computer after completing this command.

This example shows a typical system response to a LIST command:

```
A:\> AFU LIST
Adaptec Flash Utility V4.0-0 B5749
(c)Adaptec Inc. 1999-2005. All Rights Reserved.
Controllers Detected and Recognized:
Controller #0 (03:05:00) Adaptec RAID 51645
```

### Save

Saves the contents of a RAID controller's flash in a UFI file. The name of the UFI file is based on the controller type and can't be changed.

You must restart the computer following a SAVE command.

The command syntax for the SAVE command is

```
AFU SAVE [/C<Controller ID>] [/D <UFI File Path>]
```

These switches are available:

- **/C <Controller ID>**—One or more RAID controller IDs representing the set of RAID controllers on which to perform the specified command. The default is 0; if the computer has multiple RAID controllers, the AFU defaults to controller 0 unless you specify otherwise.

For example:

To specify a single RAID controller ID: `/C 0`

To specify multiple IDs separated by commas: `/C 0,2`

To indicate all RAID controllers: `ALL`

If you are using multiple RAID controllers, you must specify the controller you want by using the `/C` switch; otherwise, the AFU displays an error message and exits.

- **/D <EFI File Path>**—Specifies the path where the EFI files are located. If you do not specify the `/D` switch, the AFU looks for (or creates) its EFI files in the default location.

You cannot specify the name of a EFI file, only its path. EFI filenames are predefined, based on the RAID controller type.

In this example, the AFU saves flash contents from RAID controller 0 to a EFI file in the current default drive and directory:

```
A:\> AFU SAVE /C 0
```

In this example, the AFU saves flash contents from Controller 1 to a EFI file in `C:\EFI_FILES`:

```
A:\> AFU SAVE /C 1 /D C:\EFI_FILES
```

## Update

Updates the flash components of one or more RAID controllers on your computer from the flash image data in a EFI file. You must restart the computer following an `UPDATE` command.

The command syntax for the `UPDATE` command is:

```
AFU UPDATE [/C<Controller ID>] [/D <EFI File Path>]
```

This example shows a typical system response after an update.

```
A:\> AFU UPDATE /C 0
Adaptec Flash Utility V4.0-0 B5749
(c)Adaptec Inc. 1999-2005. All Rights Reserved.
Updating Controller 0 (Adaptec RAID 31205)
Reading flash image file (Build 5749)
AFU is about to update firmware on controllers Adaptec RAID 51645
***PLEASE DO NOT REBOOT THE SYSTEM DURING THE UPDATE***
This might take a few minutes.
Writing Adaptec RAID 51645 (4MB) Flash Image to controller 0...OK.
Verifying...OK
Please restart the computer to allow firmware changes to take effect.
```



## Verify

Compares the contents of each of the flash components on a RAID controller to the corresponding image in a UFI file, and indicates whether they match. After using the VERIFY command, you must restart the computer.

The command syntax for the VERIFY command is as follows:

```
AFU VERIFY [/C<Controller ID>] [/D <UFI File Path>]
```

This example shows a typical system response after a VERIFY command.

```
A:\> AFU VERIFY /C 0
Adaptec Flash Utility V4.0-0 B5749
(c)Adaptec Inc. 1999-2005. All Rights Reserved.
Reading flash image file (Build 5748)
Controller #0: Adaptec RAID 51645
ROM: Checksum: 797B [VALID] (Build 5748)
File: Checksum: 797B [VALID] (Build 5748)
      Image Compares Correctly
```

## Version

Displays version information about the flash components on a RAID controller. After using the VERSION command, restart your computer.

The command syntax for the VERSION command is:

```
AFU VERSION [/C<Controller ID>]
```

This example displays version information about all supported RAID controllers.

```
A:\> AFU VERSION /C 0
Adaptec Flash Utility V4.0-0 B5749
(c)Adaptec Inc. 1999-2005. All Rights Reserved.
Version Information for Controller #0 (Adaptec RAID 51645)
ROM: Build 5748 [VALID] Fri Sep 27 13:28:40 EDT 2005
A:\> AFU VERSION /C ALL
```

## Help

Displays a summary of AFU functions and command switches. For example:

```
A:\> AFU HELP
A:\> AFU /?
```

## Updating the Flash Using the AFU Command Line

- 1 Create the firmware update disks (see [page 117](#)).
- 2 Shut down your operating system and reboot to DOS from a bootable DOS floppy disk or from a DOS partition on a bootable drive. (You can use a disk connected to the controller you're updating.) If your computer isn't set up to boot from the bootable floppy disk or a bootable device other than a disk drive, enter the system setup utility to change the setting.
- 3 Insert the firmware update disk containing AFU.exe
- 4 At the DOS command, if you have multiple controllers and you don't know the number of the controller you want to update, type `AFU LIST`, then press **Enter**. Otherwise, skip to the next step.
- 5 At the DOS command, type `AFU` followed by a command (see [page 118](#)) and any switches you want.
- 6 Update the flash using the instructions suitable for your requirements:
  - **To update a single RAID controller:**  

```
AFU UPDATE /C <cont_number>
```

Where `<cont_number>` is the number of the RAID controller whose firmware you are updating. For example, to upgrade Controller 0, type `AFU UPDATE /C 0`
  - **To update multiple RAID controllers:**  

```
AFU UPDATE /C <cont_number_a>,<cont_number_b>
```

Where `<controller_number_a>` and `<controller_number_b>` are the numbers of the Adaptec RAID controllers whose firmware you are updating. For example, to upgrade controllers 0, 2, and 3, type `AFU UPDATE /C 0, 2, 3`
  - **To update all RAID controllers simultaneously:**  

```
AFU UPDATE /C all
```

**Note:** The UFI file identifies the RAID controllers, so you don't have to worry about flashing the wrong controller.
- 7 When prompted, insert the first firmware disk into your floppy disk drive.  
The AFU reads the first disk.
- 8 When prompted, remove the first firmware disk and insert the second firmware disk into your floppy disk drive.
- 9 Repeat [Step 8](#) as required until the flash update is complete.

# Controller LED and I2C Connector Quick Reference



## In this appendix...

Adaptec RAID 5085 LED Connector Specification.....	123
Adaptec RAID 5405/5405Z LED and I2C Connector Specification.....	125
Adaptec RAID 5445/5445Z LED and I2C Connector Specification.....	126
Adaptec RAID 5805/5805Q/5805Z/5805ZQ LED and I2C Connector Specification .....	128
Adaptec RAID 51245 LED and I2C Connector Specification.....	130
Adaptec RAID 51645 LED and I2C Connector Specification.....	132
Adaptec RAID 52445 LED and I2C Connector Specification.....	134
Adaptec RAID 2045 LED Connector Specification.....	137
Adaptec RAID 2405/2405Q LED and I2C Connector Specification .....	137
Adaptec RAID 2805 LED and I2C Connector Specification.....	138
Adaptec RAID 6405/6445 LED and I2C Connector Specification .....	139
Adaptec RAID 6805/6805Q LED and I2C Connector Specification .....	141
Adaptec RAID 6405E LED Connector Specification.....	142
Adaptec RAID 6805E LED Connector Specification.....	143
Adaptec RAID 6405T LED Connector Specification .....	144
Adaptec RAID 6805T/6805TQ LED Connector Specification.....	145

This chapter provides a reference guide for Adaptec RAID controllers of Activity LED and I2C connectors.

## Adaptec RAID 5085 LED Connector Specification

2249100-R

ASR-5085/512MB RoHS SGL

- Adaptec RAID 5085 Activity LED Header Connector: Molex 10-89-7162 or equivalent
- Activity LED Header Mating Cable Connector: Molex 22-55-2161 or equivalent

J2:

J2 Pin Number	Signal	Description	22-55-2161 Pin Number
1	+3.3V	LED Anode	2
2	ACTIVITY CNO, LANE 0	LED Cathode	1
3	+3.3V	LED Anode	4
4	ACTIVITY CNO, LANE 1	LED Cathode	3
5	+3.3V	LED Anode	6
6	ACTIVITY CNO, LANE 2	LED Cathode	5
7	+3.3V	LED Anode	8
8	ACTIVITY CNO, LANE 3	LED Cathode	7
9	+3.3V	LED Anode	10
10	ACTIVITY CN1, LANE 0	LED Cathode	9
11	+3.3V	LED Anode	12
12	ACTIVITY CN1, LANE 1	LED Cathode	11
13	+3.3V	LED Anode	14
14	ACTIVITY CN1, LANE 2	LED Cathode	13
15	+3.3V	LED Anode	16
16	ACTIVITY CN1, LANE 3	LED Cathode	15

- Adaptec RAID 5085 Aggregate Activity LED Board Connector: Molex 22-28-4023 or equivalent
- Aggregate LED Mating Cable Connector: Molex 50-57-9002 or equivalent

J1:

J1 Pin Number	Signal	Description
2	ACTIVITY	LED Cathode
1	+3.3V	LED Anode

- Adaptec RAID 5085 External Alarm Connector: Molex 22-28-4023 or equivalent
- Alarm Mating Cable Connector: Molex 50-57-9002 or equivalent

J12:

J12 Pin Number	Signal	Description
2	~2kHz Square Wave	Open collector transistor
1	+3.3V	

- **Adaptec RAID 5085 Status LED Board Connector:** Molex 10-89-7162 or equivalent
- **Status LED Mating Cable Connector:** Molex 22-55-2161 or equivalent

J14:

J14 Pin Number	Signal	Description	22-55-2161 Pin Number
1	+3.3V	LED Anode	2
2	STATUS CN0, LANE 0	LED Cathode	1
3	+3.3V	LED Anode	4
4	STATUS CN0, LANE 1	LED Cathode	3
5	+3.3V	LED Anode	6
6	STATUS CN0, LANE 2	LED Cathode	5
7	+3.3V	LED Anode	8
8	STATUS CN0, LANE 3	LED Cathode	7
9	+3.3V	LED Anode	10
10	STATUS CN1, LANE 0	LED Cathode	9
11	+3.3V	LED Anode	12
12	STATUS CN1, LANE 1	LED Cathode	11
13	+3.3V	LED Anode	14
14	STATUS CN1, LANE 2	LED Cathode	13
15	+3.3V	LED Anode	16
16	STATUS CN1, LANE 3	LED Cathode	15

## Adaptec RAID 5405/5405Z LED and I2C Connector Specification

2258100-R	ASR-5405 RoHS KIT
2258200-R	ASR-5405 RoHS Single
2266800-R	ASR-5405Z RoHS Single

- Adaptec RAID 5405/5405Z Activity LED Header Connector: Molex 10-89-7162 or equivalent
- Activity LED Header Mating Cable Connector: Molex 22-55-2161 or equivalent

J2:

J2 Pin Number	Signal	Description	22-55-2161 Pin Number
1	+3.3V	LED Anode	2
2	ACTIVITY CNO, LANE 0	LED Cathode	1
3	+3.3V	LED Anode	4
4	ACTIVITY CNO, LANE 1	LED Cathode	3
5	+3.3V	LED Anode	6
6	ACTIVITY CNO, LANE 2	LED Cathode	5
7	+3.3V	LED Anode	8
8	ACTIVITY CNO, LANE 3	LED Cathode	7

- Adaptec RAID 5405/5405Z Aggregate Activity LED Board Connector: Molex 22-28-4023 or equivalent
- Aggregate LED Mating Cable Connector: Molex 50-57-9002 or equivalent

J1:

J1 Pin Number	Signal	Description
2	ACTIVITY	LED Cathode
1	+3.3V	LED Anode

- Adaptec RAID 5405/5405Z External Alarm Connector: Molex 22-28-4023 or equivalent
- Alarm Mating Cable Connector: Molex 50-57-9002 or equivalent

J12:

J12 Pin Number	Signal	Description
2	~2kHz Square Wave	Open collector transistor
1	+3.3V	—

- Adaptec RAID 5405/5405Z I2C Board Connector: Molex 22-43-6030 or equivalent
- I2C Mating Cable Connector: Molex 22-43-3030 or equivalent

J4:

J4 Pin Number	Signal
3	I2C Clock
2	Ground
1	I2C Data

- **Adaptec RAID 5405 Status LED Board Connector:** Molex 10-89-7162 or equivalent
- **Status LED Mating Cable Connector:** Molex 22-55-2161 or equivalent

J14 (Adaptec RAID 5405 only):

J14 Pin Number	Signal	Description	22-55-2161 Pin Number
1	+3.3V	LED Anode	2
2	STATUS CNO, LANE 0	LED Cathode	1
3	+3.3V	LED Anode	4
4	STATUS CNO, LANE 1	LED Cathode	3
5	+3.3V	LED Anode	6
6	STATUS CNO, LANE 2	LED Cathode	5
7	+3.3V	LED Anode	8
8	STATUS CNO, LANE 3	LED Cathode	7

## Adaptec RAID 5445/5445Z LED and I2C Connector Specification

2228800-R	ASR-5445 RoHS Kit
2244900-R	ASR-5445/512MB RoHS SGL
2267000-R	ASR-5445Z RoHS Single

- **Adaptec RAID 5445/5445Z Activity LED Header Connector:** Molex 10-89-7162 or equivalent
- **Activity LED Header Mating Cable Connector:** Molex 22-55-2161 or equivalent

J2:

**Note:** For Adaptec RAID 5445, header J2 is a 16-pin connector (pins 1-16). For Adaptec RAID 5445Z, header J2 is an 8-pin connector (pins 1-8 only).

J2 Pin Number	Signal	Description	22-55-2161 Pin Number
1	+3.3V	LED Anode	2
2	ACTIVITY CNO, LANE 0	LED Cathode	1
3	+3.3V	LED Anode	4
4	ACTIVITY CNO, LANE 1	LED Cathode	3
5	+3.3V	LED Anode	6

J2 Pin Number	Signal	Description	22-55-2161 Pin Number
6	ACTIVITY CNO, LANE 2	LED Cathode	5
7	+3.3V	LED Anode	8
8	ACTIVITY CNO, LANE 3	LED Cathode	7
9	+3.3V	LED Anode	10
10	ACTIVITY CN1, LANE 0	LED Cathode	9
11	+3.3V	LED Anode	12
12	ACTIVITY CN1, LANE 1	LED Cathode	11
13	+3.3V	LED Anode	14
14	ACTIVITY CN1, LANE 2	LED Cathode	13
15	+3.3V	LED Anode	16
16	ACTIVITY CN1, LANE 3	LED Cathode	15

- **Adaptec RAID 5445/5445Z Aggregate Activity LED Board Connector:** Molex 22-28-4023 or equivalent
- **Aggregate LED Mating Cable Connector:** Molex 50-57-9002 or equivalent

J1:

J1 Pin Number	Signal	Description
2	ACTIVITY	LED Cathode
1	+3.3V	LED Anode

- **Adaptec RAID 5445/5445Z External Alarm Connector:** Molex 22-28-4023 or equivalent
- **Alarm Mating Cable Connector:** Molex 50-57-9002 or equivalent

J12:

J12 Pin Number	Signal	Description
2	~2kHz Square Wave	Open collector transistor
1	+3.3V	—

- **Adaptec RAID 5445/5445Z I2C Board Connector:** Molex 22-43-6030 or equivalent
- **I2C Mating Cable Connector:** Molex 22-43-3030 or equivalent

J4:

J4 Pin Number	Signal
3	I2C Clock
2	Ground
1	I2C Data

- **Adaptec RAID 5445 Status LED Board Connector:** Molex 10-89-7162 or equivalent
- **Status LED Mating Cable Connector:** Molex 22-55-2161 or equivalent



J14 (Adaptec RAID 5445 only):

J14 Pin Number	Signal	Description	22-55-2161 Pin Number
1	+3.3V	LED Anode	2
2	STATUS CNO, LANE 0	LED Cathode	1
3	+3.3V	LED Anode	4
4	STATUS CNO, LANE 1	LED Cathode	3
5	+3.3V	LED Anode	6
6	STATUS CNO, LANE 2	LED Cathode	5
7	+3.3V	LED Anode	8
8	STATUS CNO, LANE 3	LED Cathode	7
9	+3.3V	LED Anode	10
10	STATUS CN1, LANE 0	LED Cathode	9
11	+3.3V	LED Anode	12
12	STATUS CN1, LANE 1	LED Cathode	11
13	+3.3V	LED Anode	14
14	STATUS CN1, LANE 2	LED Cathode	13
15	+3.3V	LED Anode	16
16	STATUS CN1, LANE 3	LED Cathode	15

## Adaptec RAID 5805/5805Q/5805Z/5805ZQ LED and I2C Connector Specification

2244100-R	ASR-5805 RoHS KIT
2244300-R	ASR-5805/512MB RoHS Single
2266900-R	ASR-5805Z RoHS Single
2268500-R	ASR-5805Q RoHS Single
2268600-R	ASR-5805ZQ RoHS Single

- Adaptec RAID 5805/5805Q/5805Z/5805ZQ Activity LED Header Connector: Molex 10-89-7162 or equivalent
- Activity LED Header Mating Cable Connector: Molex 22-55-2161 or equivalent

J2:

J2 Pin Number	Signal	Description	22-55-2161 Pin Number
1	+3.3V	LED Anode	2
2	ACTIVITY CNO, LANE 0	LED Cathode	1
3	+3.3V	LED Anode	4
4	ACTIVITY CNO, LANE 1	LED Cathode	3
5	+3.3V	LED Anode	6
6	ACTIVITY CNO, LANE 2	LED Cathode	5

J2 Pin Number	Signal	Description	22-55-2161 Pin Number
7	+3.3V	LED Anode	8
8	ACTIVITY CN0, LANE 3	LED Cathode	7
9	+3.3V	LED Anode	10
10	ACTIVITY CN1, LANE 0	LED Cathode	9
11	+3.3V	LED Anode	12
12	ACTIVITY CN1, LANE 1	LED Cathode	11
13	+3.3V	LED Anode	14
14	ACTIVITY CN1, LANE 2	LED Cathode	13
15	+3.3V	LED Anode	16
16	ACTIVITY CN1, LANE 3	LED Cathode	15

- **Adaptec RAID 5805/5805Q/5805Z/5805ZQ Aggregate Activity LED Board Connector:** Molex 22-28-4023 or equivalent
- **Aggregate LED Mating Cable Connector:** Molex 50-57-9002 or equivalent

J1:

J1 Pin Number	Signal	Description
2	ACTIVITY	LED Cathode
1	+3.3V	LED Anode

- **Adaptec RAID 5805/5805Q/5805Z/5805ZQ External Alarm Connector:** Molex 22-28-4023 or equivalent
- **Alarm Mating Cable Connector:** Molex 50-57-9002 or equivalent

J12:

J12 Pin Number	Signal	Description
2	~2kHz Square Wave	Open collector transistor
1	+3.3V	—

- **Adaptec RAID 5805/5805Q/5805Z/5805ZQ I2C CN0 Board Connector:** Molex 22-43-6030 or equivalent
- **I2C Mating Cable Connector:** Molex 22-43-3030 or equivalent

J4:

J4 Pin Number	Signal
3	I2C Clock
2	Ground
1	I2C Data

- **Adaptec RAID 5805/5805Q/5805Z/5805ZQ I2C CN1 Board Connector:** Molex 22-43-6030 or equivalent
- **I2C Mating Cable Connector:** Molex 22-43-3030 or equivalent

J5:

J5 Pin Number	Signal
3	I2C Clock
2	Ground
1	I2C Data

- **Adaptec RAID 5805/5805Q Status LED Board Connector:** Molex 10-89-7162 or equivalent
- **Status LED Mating Cable Connector:** Molex 22-55-2161 or equivalent

J14 (Adaptec RAID 5805/5805Q only):

J14 Pin Number	Signal	Description	22-55-2161 Pin Number
1	+3.3V	LED Anode	2
2	STATUS CN0, LANE 0	LED Cathode	1
3	+3.3V	LED Anode	4
4	STATUS CN0, LANE 1	LED Cathode	3
5	+3.3V	LED Anode	6
6	STATUS CN0, LANE 2	LED Cathode	5
7	+3.3V	LED Anode	8
8	STATUS CN0, LANE 3	LED Cathode	7
9	+3.3V	LED Anode	10
10	STATUS CN1, LANE 0	LED Cathode	9
11	+3.3V	LED Anode	12
12	STATUS CN1, LANE 1	LED Cathode	11
13	+3.3V	LED Anode	14
14	STATUS CN1, LANE 2	LED Cathode	13
15	+3.3V	LED Anode	16
16	STATUS CN1, LANE 3	LED Cathode	15

## Adaptec RAID 51245 LED and I2C Connector Specification

2268200-R	ASR-51245 RoHS Kit
2268300-R	ASR-51245 RoHS Single

- **Adaptec RAID 51245 Activity LED Header Connector for CN0/CN1:** Molex 10-89-7162 or equivalent
- **Activity LED Header Mating Cable Connector:** Molex 22-55-2161 or equivalent

J3:

J3 Pin Number	Signal	Description	22-55-2161 Pin Number
1	+3.3V	LED Anode	2
2	ACTIVITY CN1, LANE 0	LED Cathode	1
3	+3.3V	LED Anode	4
4	ACTIVITY CN1, LANE 1	LED Cathode	3
5	+3.3V	LED Anode	6
6	ACTIVITY CN1, LANE 2	LED Cathode	5
7	+3.3V	LED Anode	8
8	ACTIVITY CN1, LANE 3	LED Cathode	7
9	+3.3V	LED Anode	10
10	ACTIVITY CNO, LANE 0	LED Cathode	9
11	+3.3V	LED Anode	12
12	ACTIVITY CNO, LANE 1	LED Cathode	11
13	+3.3V	LED Anode	14
14	ACTIVITY CNO, LANE 2	LED Cathode	13
15	+3.3V	LED Anode	16
16	ACTIVITY CNO, LANE 3	LED Cathode	15

- Adaptec RAID 51245 Activity LED Board Connector for CN2: Molex 10-89-7162 or equivalent
- Activity LED Mating Cable Connector: Molex 22-55-2161 or equivalent

J1:

J1 Pin Number	Signal	Description	22-55-2161 Pin Number
1	Unused	Unused	2
2	Unused	Unused	1
3	Unused	Unused	4
4	Unused	Unused	3
5	Unused	Unused	6
6	Unused	Unused	5
7	Unused	Unused	8
8	Unused	Unused	7
9	+3.3V	LED Anode	10
10	ACTIVITY CN2, LANE 0	LED Cathode	9
11	+3.3V	LED Anode	12
12	ACTIVITY CN2, LANE 1	LED Cathode	11
13	+3.3V	LED Anode	14
14	ACTIVITY CN2, LANE 2	LED Cathode	13
15	+3.3V	LED Anode	16
16	ACTIVITY CN2, LANE 3	LED Cathode	15

- Adaptec RAID 51245 Aggregate Activity LED Board Connector: Molex 22-28-4023 or equivalent
- Aggregate LED Mating Cable Connector: Molex 50-57-9002 or equivalent

J10:

J10 Pin Number	Signal	Description
2	ACTIVITY	LED Cathode
1	+3.3V	LED Anode

- Adaptec RAID 51245 External Alarm Connector: Molex 22-28-4023 or equivalent
- Alarm Mating Cable Connector: Molex 50-57-9002 or equivalent

J12:

J12 Pin Number	Signal	Description
2	~2kHz Square Wave	Open collector transistor
1	+3.3V	—

- Adaptec RAID 51245 I2C Board Connector: Molex 22-43-6030 or equivalent
- I2C Mating Cable Connector: Molex 22-43-3030 or equivalent

J28, J29, J30:

J2x Pin Number	Signal
3	I2C Clock
2	Ground
1	I2C Data

## Adaptec RAID 51645 LED and I2C Connector Specification

2258500-R	ASR-51645 RoHS Kit
2258600-R	ASR-51645 RoHS Single

- Adaptec RAID 51645 Activity LED Header Connector for CN0/CN1: Molex 10-89-7162 or equivalent
- Activity LED Header Mating Cable Connector: Molex 22-55-2161 or equivalent

J3:

J3 Pin Number	Signal	Description	22-55-2161 Pin Number
1	+3.3V	LED Anode	2
2	ACTIVITY CN1, LANE 0	LED Cathode	1
3	+3.3V	LED Anode	4
4	ACTIVITY CN1, LANE 1	LED Cathode	3
5	+3.3V	LED Anode	6

J3 Pin Number	Signal	Description	22-55-2161 Pin Number
6	ACTIVITY CN1, LANE 2	LED Cathode	5
7	+3.3V	LED Anode	8
8	ACTIVITY CN1, LANE 3	LED Cathode	7
9	+3.3V	LED Anode	10
10	ACTIVITY CNO, LANE 0	LED Cathode	9
11	+3.3V	LED Anode	12
12	ACTIVITY CNO, LANE 1	LED Cathode	11
13	+3.3V	LED Anode	14
14	ACTIVITY CNO, LANE 2	LED Cathode	13
15	+3.3V	LED Anode	16
16	ACTIVITY CNO, LANE 3	LED Cathode	15

- Adaptec RAID 51645 Activity LED Board Connector for CN2/CN3: Molex 10-89-7162 or equivalent
- Activity LED Mating Cable Connector: Molex 22-55-2161 or equivalent

J1:

J1 Pin Number	Signal	Description	22-55-2161 Pin Number
1	+3.3V	LED Anode	2
2	ACTIVITY CN3, LANE 0	LED Cathode	1
3	+3.3V	LED Anode	4
4	ACTIVITY CN3, LANE 1	LED Cathode	3
5	+3.3V	LED Anode	6
6	ACTIVITY CN3, LANE 2	LED Cathode	5
7	+3.3V	LED Anode	8
8	ACTIVITY CN3, LANE 3	LED Cathode	7
9	+3.3V	LED Anode	10
10	ACTIVITY CN2, LANE 0	LED Cathode	9
11	+3.3V	LED Anode	12
12	ACTIVITY CN2, LANE 1	LED Cathode	11
13	+3.3V	LED Anode	14
14	ACTIVITY CN2, LANE 2	LED Cathode	13
15	+3.3V	LED Anode	16
16	ACTIVITY CN2, LANE 3	LED Cathode	15

- Adaptec RAID 51645 Aggregate Activity LED Board Connector: Molex 22-28-4023 or equivalent
- Aggregate LED Mating Cable Connector: Molex 50-57-9002 or equivalent

J10:

J10 Pin Number	Signal	Description
2	ACTIVITY	LED Cathode
1	+3.3V	LED Anode

- Adaptec RAID 51645 External Alarm Connector: Molex 22-28-4023 or equivalent
- Alarm Mating Cable Connector: Molex 50-57-9002 or equivalent

J12:

J12 Pin Number	Signal	Description
2	~2kHz Square Wave	Open collector transistor
1	+3.3V	—

- Adaptec RAID 51645 I2C Board Connector: Molex 22-43-6030 or equivalent
- I2C Mating Cable Connector: Molex 22-43-3030 or equivalent

J27, J28, J29, J30:

J2x Pin Number	Signal
3	I2C Clock
2	Ground
1	I2C Data

## Adaptec RAID 52445 LED and I2C Connector Specification

2258800-R	ASR-52445 RoHS Kit
2258700-R	ASR-52445 RoHS Single

- Adaptec RAID 52445 Activity LED Header Connector for CN0/CN1: Molex 10-89-7162 or equivalent
- Activity LED Header Mating Cable Connector: Molex 22-55-2161 or equivalent

J3:

J3 Pin Number	Signal	Description	22-55-2161 Pin Number
1	+3.3V	LED Anode	2
2	ACTIVITY CN1, LANE 0	LED Cathode	1
3	+3.3V	LED Anode	4
4	ACTIVITY CN1, LANE 1	LED Cathode	3
5	+3.3V	LED Anode	6
6	ACTIVITY CN1, LANE 2	LED Cathode	5
7	+3.3V	LED Anode	8
8	ACTIVITY CN1, LANE 3	LED Cathode	7

J3 Pin Number	Signal	Description	22-55-2161 Pin Number
9	+3.3V	LED Anode	10
10	ACTIVITY CNO, LANE 0	LED Cathode	9
11	+3.3V	LED Anode	12
12	ACTIVITY CNO, LANE 1	LED Cathode	11
13	+3.3V	LED Anode	14
14	ACTIVITY CNO, LANE 2	LED Cathode	13
15	+3.3V	LED Anode	16
16	ACTIVITY CNO, LANE 3	LED Cathode	15

- Adaptec RAID 52445 Activity LED Board Connector for CN2/CN3: Molex 10-89-7162 or equivalent
- Activity LED Mating Cable Connector: Molex 22-55-2161 or equivalent

J1:

J1 Pin Number	Signal	Description	22-55-2161 Pin Number
1	+3.3V	LED Anode	2
2	ACTIVITY CN3, LANE 0	LED Cathode	1
3	+3.3V	LED Anode	4
4	ACTIVITY CN3, LANE 1	LED Cathode	3
5	+3.3V	LED Anode	6
6	ACTIVITY CN3, LANE 2	LED Cathode	5
7	+3.3V	LED Anode	8
8	ACTIVITY CN3, LANE 3	LED Cathode	7
9	+3.3V	LED Anode	10
10	ACTIVITY CN2, LANE 0	LED Cathode	9
11	+3.3V	LED Anode	12
12	ACTIVITY CN2, LANE 1	LED Cathode	11
13	+3.3V	LED Anode	14
14	ACTIVITY CN2, LANE 2	LED Cathode	13
15	+3.3V	LED Anode	16
16	ACTIVITY CN2, LANE 3	LED Cathode	15

- Adaptec RAID 52445 Activity LED Header Connector for CN4/CN5: Molex 10-89-7162 or equivalent
- Activity LED Header Mating Cable Connector: Molex 22-55-2161 or equivalent

J2:

J2 Pin Number	Signal	Description	22-55-2161 Pin Number
1	+3.3V	LED Anode	2
2	ACTIVITY CN4, LANE 0	LED Cathode	1



J2 Pin Number	Signal	Description	22-55-2161 Pin Number
3	+3.3V	LED Anode	4
4	ACTIVITY CN4, LANE 1	LED Cathode	3
5	+3.3V	LED Anode	6
6	ACTIVITY CN4, LANE 2	LED Cathode	5
7	+3.3V	LED Anode	8
8	ACTIVITY CN4, LANE 3	LED Cathode	7
9	+3.3V	LED Anode	10
10	ACTIVITY CN5, LANE 0	LED Cathode	9
11	+3.3V	LED Anode	12
12	ACTIVITY CN5, LANE 1	LED Cathode	11
13	+3.3V	LED Anode	14
14	ACTIVITY CN5, LANE 2	LED Cathode	13
15	+3.3V	LED Anode	16
16	ACTIVITY CN5, LANE 3	LED Cathode	15

- **Adaptec RAID 52445 Aggregate Activity LED Board Connector:** Molex 22-28-4023 or equivalent
- **Aggregate LED Mating Cable Connector:** Molex 50-57-9002 or equivalent

J10:

J10 Pin Number	Signal	Description
2	ACTIVITY	LED Cathode
1	+3.3V	LED Anode

- **Adaptec RAID 52445 External Alarm Connector:** Molex 22-28-4023 or equivalent
- **Alarm Mating Cable Connector:** Molex 50-57-9002 or equivalent

J12:

J12 Pin Number	Signal	Description
2	~2kHz Square Wave	Open collector transistor
1	+3.3V	—

- **Adaptec RAID 52445 I2C Board Connector:** Molex 22-43-6030 or equivalent
- **I2C Mating Cable Connector:** Molex 22-43-3030 or equivalent

J25, J26, J27, J28, J29, J30:

J2x Pin Number	Signal
3	I2C Clock
2	Ground
1	I2C Data

## Adaptec RAID 2045 LED Connector Specification

---

2260300-R	ASR-2045 RoHS SGL
-----------	-------------------

---

- Adaptec RAID 2045 Aggregate Activity LED Board Connector: Molex 22-28-4023 or equivalent
- Aggregate LED Mating Cable Connector: Molex 50-57-9002 or equivalent

J1:

J1 Pin Number	Signal	Description
2	ACTIVITY	LED Cathode
1	+3.3V	LED Anode

---

## Adaptec RAID 2405/2405Q LED and I2C Connector Specification

---

2260100-R	ASR-2405 RoHS KIT
2260200-R	ASR-2405 RoHS SGL
2268300-R	ASR-2405Q RoHS Single

---

- Adaptec RAID 2405/2405Q Activity LED Header Connector: Molex 10-89-7082 or equivalent
- Activity LED Header Mating Cable Connector: Molex 22-55-2081 or equivalent

J2:

J2 Pin Number	Signal	Description	22-55-2161 Pin Number
1	+3.3V	LED Anode	2
2	ACTIVITY CNO, LANE 0	LED Cathode	1
3	+3.3V	LED Anode	4
4	ACTIVITY CNO, LANE 1	LED Cathode	3
5	+3.3V	LED Anode	6
6	ACTIVITY CNO, LANE 2	LED Cathode	5
7	+3.3V	LED Anode	8
8	ACTIVITY CNO, LANE 3	LED Cathode	7

---

- Adaptec RAID 2405/2405Q Aggregate Activity LED Board Connector: Molex 22-28-4023 or equivalent
  - Aggregate LED Mating Cable Connector: Molex 50-57-9002 or equivalent
-

J1:

J1 Pin Number	Signal	Description
2	ACTIVITY	LED Cathode
1	+3.3V	LED Anode

- Adaptec RAID 2405/2405Q I2C Board Connector: Molex 22-43-6030 or equivalent
- I2C Mating Cable Connector: Molex 22-43-3030 or equivalent

J4:

J4 Pin Number	Signal
3	I2C Clock
2	Ground
1	I2C Data

## Adaptec RAID 2805 LED and I2C Connector Specification

2269600-R	ASR-2805 RoHS KIT
2269500-R	ASR-2805 RoHS SGL

- Adaptec RAID 2805 Activity LED Header Connector: Molex 10-89-7162 or equivalent
- Activity LED Header Mating Cable Connector: Molex 22-55-2161 or equivalent

J2:

J2 Pin Number	Signal	Description	22-55-2161 Pin Number
1	+3.3V	LED Anode	2
2	ACTIVITY CNO, LANE 0	LED Cathode	1
3	+3.3V	LED Anode	4
4	ACTIVITY CNO, LANE 1	LED Cathode	3
5	+3.3V	LED Anode	6
6	ACTIVITY CNO, LANE 2	LED Cathode	5
7	+3.3V	LED Anode	8
8	ACTIVITY CNO, LANE 3	LED Cathode	7
9	+3.3V	LED Anode	10
10	ACTIVITY CN1, LANE 0	LED Cathode	9
11	+3.3V	LED Anode	12
12	ACTIVITY CN1, LANE 1	LED Cathode	11
13	+3.3V	LED Anode	14
14	ACTIVITY CN1, LANE 2	LED Cathode	13
15	+3.3V	LED Anode	16
16	ACTIVITY CN1, LANE 3	LED Cathode	15

- Adaptec RAID 2805 Aggregate Activity LED Board Connector: Molex 22-28-4023 or equivalent
- Aggregate LED Mating Cable Connector: Molex 50-57-9002 or equivalent

J1:

J1 Pin Number	Signal	Description
2	ACTIVITY	LED Cathode
1	+3.3V	LED Anode

- Adaptec RAID 2805 I2C CN0 Board Connector: Molex 22-43-6030 or equivalent
- I2C Mating Cable Connector: Molex 22-43-3030 or equivalent

J4:

J4 Pin Number	Signal
3	I2C Clock
2	Ground
1	I2C Data

- Adaptec RAID 2805 I2C CN1 Board Connector: Molex 22-43-6030 or equivalent
- I2C Mating Cable Connector: Molex 22-43-3030 or equivalent

J5:

J4 Pin Number	Signal
3	I2C Clock
2	Ground
1	I2C Data

## Adaptec RAID 6405/6445 LED and I2C Connector Specification

2271100-R	ASR-6405 Kit
2270000-R	ASR-6405 SGL
2270200-R	ASR-6445 SGL

- Adaptec RAID 6405/6445 Activity LED Header Connector: Molex 22-43-6030 or equivalent
- Activity LED Header Mating Cable Connector: Molex 22-55-2161 or equivalent

J2:

J2 Pin Number	Signal	Description	22-55-2161 Pin Number
1	+3.3V	LED Anode	2
2	ACTIVITY CN0, LANE 0	LED Cathode	1

J2 Pin Number	Signal	Description	22-55-2161 Pin Number
3	+3.3V	LED Anode	4
4	ACTIVITY CNO, LANE 1	LED Cathode	3
5	+3.3V	LED Anode	6
6	ACTIVITY CNO, LANE 2	LED Cathode	5
7	+3.3V	LED Anode	8
8	ACTIVITY CNO, LANE 3	LED Cathode	7

- Adaptec RAID 6405/6445 Aggregate Activity LED Board Connector: Molex 22-28-4023 or equivalent
- Aggregate LED Mating Cable Connector: Molex 50-57-9002 or equivalent

J1:

J1 Pin Number	Signal	Description
2	ACTIVITY	LED Cathode
1	+3.3V	LED Anode

- Adaptec RAID 6405/6445 External Alarm Connector: Molex 22-28-4023 or equivalent
- Alarm Mating Cable Connector: Molex 50-57-9002 or equivalent

J12:

J12 Pin Number	Signal	Description
2	~2kHz Square Wave	Open collector transistor
1	+3.3V	—

- Adaptec RAID 6405/6445 I2C CN0 Board Connector: Molex 22-43-6030 or equivalent
- I2C Mating Cable Connector: Molex 22-43-3030 or equivalent

J4:

J4 Pin Number	Signal
3	I2C Clock, CNO
2	Ground
1	I2C Data, CNO

## Adaptec RAID 6805/6805Q LED and I2C Connector Specification

2271200-R	ASR-6805 Kit
2270100-R	ASR-6805 SGL
2270700-R	ASR-6805Q SGL

- Adaptec RAID 6805/6805Q Activity LED Header Connector: Molex 22-43-6030 or equivalent
- Activity LED Header Mating Cable Connector: Molex 22-55-2161 or equivalent

J2:

J2 Pin Number	Signal	Description	22-55-2161 Pin Number
1	+3.3V	LED Anode	2
2	ACTIVITY CNO, LANE 0	LED Cathode	1
3	+3.3V	LED Anode	4
4	ACTIVITY CNO, LANE 1	LED Cathode	3
5	+3.3V	LED Anode	6
6	ACTIVITY CNO, LANE 2	LED Cathode	5
7	+3.3V	LED Anode	8
8	ACTIVITY CNO, LANE 3	LED Cathode	7
9	+3.3V	LED Anode	10
10	ACTIVITY CN1, LANE 0	LED Cathode	9
11	+3.3V	LED Anode	12
12	ACTIVITY CN1, LANE 1	LED Cathode	11
13	+3.3V	LED Anode	14
14	ACTIVITY CN1, LANE 2	LED Cathode	13
15	+3.3V	LED Anode	16
16	ACTIVITY CN1, LANE 3	LED Cathode	15

- Adaptec RAID 6805/6805Q Aggregate Activity LED Board Connector: Molex 22-28-4023 or equivalent
- Aggregate LED Mating Cable Connector: Molex 50-57-9002 or equivalent

J1:

J1 Pin Number	Signal	Description
2	ACTIVITY	LED Cathode
1	+3.3V	LED Anode

- Adaptec RAID 6805/6805Q External Alarm Connector: Molex 22-28-4023 or equivalent
- Alarm Mating Cable Connector: Molex 50-57-9002 or equivalent

J12:

J12 Pin Number	Signal	Description
2	~2kHz Square Wave	Open collector transistor
1	+3.3V	—

- Adaptec RAID 6805/6805Q I2C CN0 Board Connector: Molex 22-43-6030 or equivalent
- I2C Mating Cable Connector: Molex 22-43-3030 or equivalent

J4:

J4 Pin Number	Signal
3	I2C Clock, CN0
2	Ground
1	I2C Data, CN0

- Adaptec RAID 6805/6805Q I2C CN1 Board Connector: Molex 22-43-6030 or equivalent
- I2C Mating Cable Connector: Molex 22-43-3030 or equivalent

J5:

J4 Pin Number	Signal
3	I2C Clock, CN1
2	Ground
1	I2C Data, CN1

## Adaptec RAID 6405E LED Connector Specification

2271700-R	ASR-6405E Kit
2270800-R	ASR-6405E SGL

- Adaptec RAID 6405E Activity LED Header Connector: Molex 22-43-6030 or equivalent
- Activity LED Header Mating Cable Connector: Molex 22-55-2161 or equivalent

J2:

J2 Pin Number	Signal	Description	22-55-2161 Pin Number
1	+3.3V	LED Anode	2
2	ACTIVITY CNO, LANE 0	LED Cathode	1
3	+3.3V	LED Anode	4
4	ACTIVITY CNO, LANE 1	LED Cathode	3
5	+3.3V	LED Anode	6
6	ACTIVITY CNO, LANE 2	LED Cathode	5
7	+3.3V	LED Anode	8
8	ACTIVITY CNO, LANE 3	LED Cathode	7

- Adaptec RAID 6405E Aggregate Activity LED Board Connector: Molex 22-28-4023 or equivalent
- Aggregate LED Mating Cable Connector: Molex 50-57-9002 or equivalent

J1:

J1 Pin Number	Signal	Description
2	ACTIVITY	LED Cathode
1	+3.3V	LED Anode

- Adaptec RAID 6405E External Alarm Connector: Molex 22-28-4023 or equivalent
- Alarm Mating Cable Connector: Molex 50-57-9002 or equivalent

J12:

J12 Pin Number	Signal	Description
2	~2kHz Square Wave	Open collector transistor
1	+3.3V	—

## Adaptec RAID 6805E LED Connector Specification

2271800-R	ASR-6805E Kit
2270900-R	ASR-6805E SGL

- Adaptec RAID 6805E Activity LED Header Connector: Molex 22-43-6030 or equivalent
- Activity LED Header Mating Cable Connector: Molex 22-55-2161 or equivalent

J2:

J2 Pin Number	Signal	Description	22-55-2161 Pin Number
1	+3.3V	LED Anode	2
2	ACTIVITY CNO, LANE 0	LED Cathode	1
3	+3.3V	LED Anode	4
4	ACTIVITY CNO, LANE 1	LED Cathode	3
5	+3.3V	LED Anode	6
6	ACTIVITY CNO, LANE 2	LED Cathode	5
7	+3.3V	LED Anode	8
8	ACTIVITY CNO, LANE 3	LED Cathode	7
9	+3.3V	LED Anode	10
10	ACTIVITY CN1, LANE 0	LED Cathode	9
11	+3.3V	LED Anode	12
12	ACTIVITY CN1, LANE 1	LED Cathode	11
13	+3.3V	LED Anode	14
14	ACTIVITY CN1, LANE 2	LED Cathode	13



J2 Pin Number	Signal	Description	22-55-2161 Pin Number
15	+3.3V	LED Anode	16
16	ACTIVITY CN1, LANE 3	LED Cathode	15

- Adaptec RAID 6805E Aggregate Activity LED Board Connector: Molex 22-28-4023 or equivalent
- Aggregate LED Mating Cable Connector: Molex 50-57-9002 or equivalent

J1:

J1 Pin Number	Signal	Description
2	ACTIVITY	LED Cathode
1	+3.3V	LED Anode

- Adaptec RAID 6805E External Alarm Connector: Molex 22-28-4023 or equivalent
- Alarm Mating Cable Connector: Molex 50-57-9002 or equivalent

J12:

J12 Pin Number	Signal	Description
2	~2kHz Square Wave	Open collector transistor
1	+3.3V	—

## Adaptec RAID 6405T LED Connector Specification

2272700-R	ASR-6405T SGL
-----------	---------------

- Adaptec RAID 6405T Activity LED Header Connector: Molex 22-43-6030 or equivalent
- Activity LED Header Mating Cable Connector: Molex 22-55-2161 or equivalent

J2:

J2 Pin Number	Signal	Description	22-55-2161 Pin Number
1	+3.3V	LED Anode	2
2	ACTIVITY CNO, LANE 0	LED Cathode	1
3	+3.3V	LED Anode	4
4	ACTIVITY CNO, LANE 1	LED Cathode	3
5	+3.3V	LED Anode	6
6	ACTIVITY CNO, LANE 2	LED Cathode	5
7	+3.3V	LED Anode	8
8	ACTIVITY CNO, LANE 3	LED Cathode	7

- Adaptec RAID 6405T Aggregate Activity LED Board Connector: Molex 22-28-4023 or equivalent
- Aggregate LED Mating Cable Connector: Molex 50-57-9002 or equivalent

J1:

J1 Pin Number	Signal	Description
2	ACTIVITY	LED Cathode
1	+3.3V	LED Anode

- Adaptec RAID 6405T External Alarm Connector: Molex 22-28-4023 or equivalent
- Alarm Mating Cable Connector: Molex 50-57-9002 or equivalent

J12:

J12 Pin Number	Signal	Description
2	~2kHz Square Wave	Open collector transistor
1	+3.3V	—

## Adaptec RAID 6805T/6805TQ LED Connector Specification

2272800-R	ASR-6805T SGL
2273700-R	ASR-6805T with AFM-600 Bulk
2273600-R	ASR-6805TQ SGL

- Adaptec RAID 6805T/6805TQ Activity LED Header Connector: Molex 22-43-6030 or equivalent
- Activity LED Header Mating Cable Connector: Molex 22-55-2161 or equivalent

J2:

J2 Pin Number	Signal	Description	22-55-2161 Pin Number
1	+3.3V	LED Anode	2
2	ACTIVITY CNO, LANE 0	LED Cathode	1
3	+3.3V	LED Anode	4
4	ACTIVITY CNO, LANE 1	LED Cathode	3
5	+3.3V	LED Anode	6
6	ACTIVITY CNO, LANE 2	LED Cathode	5
7	+3.3V	LED Anode	8
8	ACTIVITY CNO, LANE 3	LED Cathode	7
9	+3.3V	LED Anode	10
10	ACTIVITY CN1, LANE 0	LED Cathode	9
11	+3.3V	LED Anode	12
12	ACTIVITY CN1, LANE 1	LED Cathode	11
13	+3.3V	LED Anode	14

J2 Pin Number	Signal	Description	22-55-2161 Pin Number
14	ACTIVITY CN1, LANE 2	LED Cathode	13
15	+3.3V	LED Anode	16
16	ACTIVITY CN1, LANE 3	LED Cathode	15

- **Adaptec RAID 6805T/6805TQ Aggregate Activity LED Board Connector:** Molex 22-28-4023 or equivalent
- **Aggregate LED Mating Cable Connector:** Molex 50-57-9002 or equivalent

J1:

J1 Pin Number	Signal	Description
2	ACTIVITY	LED Cathode
1	+3.3V	LED Anode

- **Adaptec RAID 6805T/6805TQ External Alarm Connector:** Molex 22-28-4023 or equivalent
- **Alarm Mating Cable Connector:** Molex 50-57-9002 or equivalent

J12:

J12 Pin Number	Signal	Description
2	~2kHz Square Wave	Open collector transistor
1	+3.3V	—

- **Adaptec RAID 6805T/6805TQ Aggregate Activity LED Board Connector:** Molex 22-28-4023 or equivalent
- **Aggregate LED Mating Cable Connector:** Molex 50-57-9002 or equivalent

J1:

J1 Pin Number	Signal	Description
2	ACTIVITY	LED Cathode
1	+3.3V	LED Anode

- **Adaptec RAID 6805T/6805TQ External Alarm Connector:** Molex 22-28-4023 or equivalent
- **Alarm Mating Cable Connector:** Molex 50-57-9002 or equivalent

J12:

J12 Pin Number	Signal	Description
2	~2kHz Square Wave	Open collector transistor
1	+3.3V	—

# Safety Information



To ensure your personal safety and the safety of your equipment:

- Keep your work area and the computer clean and clear of debris.
- Before opening the system cabinet, unplug the power cord.

## Electrostatic Discharge (ESD)

 **Caution:** ESD can damage electronic components when they are improperly handled, and can result in total or intermittent failures. Always follow ESD-prevention procedures when removing and replacing components.

To prevent ESD damage:

- Use an ESD wrist or ankle strap and ensure that it makes skin contact. Connect the equipment end of the strap to an unpainted metal surface on the chassis.  
  
If a wrist strap is not available, ground yourself by touching the metal chassis before handling the controller or any other part of the computer.
- Avoid touching the controller against your clothing. The wrist strap protects components from ESD on the body only.
- Handle the controller by its bracket or edges only. Avoid touching the printed circuit board or the connectors.
- Put the controller down only on an antistatic surface such as the bag supplied in your kit.
- If you are returning the controller to Adaptec by PMC Product Support, put it back in its antistatic bag immediately.

# Technical Specifications



**In this appendix...**

- Environmental Specifications..... 149
- DC Power Requirements..... 149
- Current Requirements..... 149

## Environmental Specifications

**Note:** Adaptec RAID controllers require adequate airflow to operate reliably. The recommended airflow is 200 LFM (linear feet per minute). **Forced airflow is recommended.**

Ambient temperature with forced airflow	0 °C to 55 °C
Ambient temperature with Battery Backup Unit (BBU) <sup>1</sup>	0 °C to 40 °C
Relative humidity	10% to 90%, noncondensing
Altitude	Up to 3,000 meters

<sup>1</sup> BBU is not supported on all controllers. See [page 19](#) for more information.

**Note:** Ambient temperature is measured 1" from RAID processor.

## DC Power Requirements

Bus Type	Description	Requirements
PCIe	Ripple and noise	50 mV peak-to-peak (max)
PCIe	DC Voltage	3.3 V ± 9%, 12 V ± 8%

## Current Requirements

Adaptec Model	Typical Current
Adaptec RAID 5085	0.45 A @ 3.3 VDC; 1.0 A @ 12.0 VDC
Adaptec RAID 5805/5805Q	0.45 A @ 3.3 VDC; 1.0 A @ 12.0 VDC
Adaptec RAID 5405	0.45A @ 3.3 VDC; 0.94A @ 12.0 VDC
Adaptec RAID 5445	0.45A @ 3.3 VDC; 1.0A @ 12.0 VDC
Adaptec RAID 5805Z/5805ZQ	0.39 A @ 3.3 VDC; 1.21 A @ 12.0 VDC
Adaptec RAID 5405Z	0.38 A @ 3.3 VDC; 1.18 A @ 12.0 VDC
Adaptec RAID 5445Z	0.40 A @ 3.3 VDC; 1.24 A @ 12.0 VDC
Adaptec RAID 51245	0.47A @ 3.3 VDC; 1.68A @ 12.0 VDC
Adaptec RAID 51645	0.47A @ 3.3 VDC; 1.72A @ 12.0 VDC
Adaptec RAID 52445	0.47A @ 3.3 VDC; 1.78A @ 12.0 VDC
Adaptec RAID 2045	0.43A @ 3.3 VDC; 0.83A @ 12.0 VDC
Adaptec RAID 2405/2405Q	0.43A @ 3.3 VDC; 0.83A @ 12.0 VDC
Adaptec RAID 2805	0.5A @ 3.3 VDC; 0.95A @ 12.0 VDC
Adaptec RAID 6405	0.17A @ 3.3 VDC; 1.25A @ 12.0 VDC
Adaptec RAID 6445	0.17A @ 3.3 VDC; 1.25A @ 12.0 VDC
Adaptec RAID 6805/6805Q	0.17A @ 3.3 VDC; 1.25A @ 12.0 VDC
Adaptec RAID 6405E	0.11A @ 3.3 VDC; 0.75A @ 12.0 VDC
Adaptec RAID 6805E	0.125A @ 3.3 VDC; 0.80A @ 12.0 VDC
Adaptec RAID 6405T	0.125A @ 3.3 VDC; 0.97A @ 12.0 VDC
Adaptec RAID 6805T/6805TQ	0.125A @ 3.3 VDC; 0.97A @ 12.0 VDC

## A

activity LED connector specifications [122](#)

ACU

arrays [55](#)

creating arrays [55](#), [105](#)

creating bootable arrays [106](#)

initializing disk drives [108](#)

managing arrays [106](#)

rescanning disk drives [108](#)

secure erasing disk drives [108](#)

stopping a secure erase [108](#)

Adaptec CIM Provider [82](#)

Adaptec customer support [3](#)

Adaptec Flash Utility. *See* AFU

Adaptec RAID Configuration utility [81](#), [104](#) to [114](#)

Adaptec RAID Controller Configuration utility. *See* ARCCONF

Adaptec Storage Manager [80](#)

creating arrays [57](#)

installing [80](#)

adapters. *See* controllers

advanced data protection [19](#)

AFU [81](#), [115](#) to [121](#)

Alarm Control setting [111](#)

ARCCONF [80](#)

Array Background Consistency Check setting [111](#), [112](#)

Array Configuration Utility. *See* ACU

array migration [18](#)

Array-based BBS Support setting [111](#)

arrays

creating (ACU) [55](#), [105](#)

creating (Adaptec Storage Manager) [57](#)

creating bootable arrays [106](#)

making an array bootable [58](#)

managing with ACU [106](#)

non-redundant [96](#)

RAID 1 [97](#)

RAID 10 [98](#)

RAID 1E [97](#)

RAID 5 [99](#)

RAID 50 [101](#)

RAID 5EE [100](#)

RAID 6 [102](#)

RAID 60 [102](#)

arrays (bootable) [54](#)

audible alarm [84](#)

automatic failover [18](#)

Automatic Failover setting [111](#)

## B

backplane connections [51](#), [92](#)

battery backup module [19](#)

batteryless backup [47](#), [48](#)

BBU [19](#)

Big Block Bypass mode [112](#)

boards. *See* controllers

boot controller [55](#)

bootable arrays [58](#)

creating [54](#), [106](#)

## C

cards. *See* controllers

CD-ROM Boot Support setting [111](#)

command line interface (flash utility) [118](#)

command line utility [80](#)

connectors [92](#), [114](#)

contents of controller kit [15](#)

controllers

- activity LED connector specifications 122
  - Alarm Control setting 111
  - Array Background Consistency Check setting 111, 112
  - Array-based BBS Support setting 111
  - array-level features 18
  - Automatic Failover setting 111
  - CD-ROM Boot Support setting 111
  - connecting disk drives 50
  - connecting external devices 53
  - CRC Checking setting 113
  - data protection 19
  - descriptions 17 to 32
  - disk drives 42
  - Drive's Write Cache setting 111
  - event log 114
  - figures 17 to 32
  - firmware 116
  - flashing 86
  - I2C connector specifications 122
  - installation options 45
  - installing 47
  - modifying general settings 111
  - modifying settings with *SerialSelect* 110
  - modifying with *SerialSelect* 113
  - Phy Rate setting 113
  - Physical Drives Display During POST setting 111
  - RAID levels 41
  - Removable Media Devices Boot Support setting 111
  - resetting 86
  - Runtime BIOS setting 111
  - SAS Address setting 113
  - SAS cables 42
  - setting boot controller 55
  - specifications 148
  - standard features
  - troubleshooting 84
  - updating firmware 116
  - upgrading firmware 19
  - copyback 19
  - CRC Checking setting 113
  - customer support 3
- D**
- direct-attach connections 50, 92
  - disk drives 42, 92
    - connecting to controllers 50
    - connections 114
    - external 53
    - failure recovery
      - multiple arrays 85
      - multiple disk drives 86
      - RAID 0 arrays 86
      - with hot spare 85
      - without hot spare 85
    - formatting 113
    - identifying 114
    - initializing 108
    - recovering from failure 85
    - rescanning 108
    - SAS identifiers 92
    - secure erasing 108
      - stopping a secure erase 108
    - solid state 18, 42, 50
    - types of connections 114
    - verifying 113
  - drive requirements 42
  - Drive's Write Cache setting 111
  - driver and operating system installation 59
  - driver disk 60
  - driver installation 72 to 78
  - drivers
    - installing on FreeBSD 78
    - installing on Solaris 76
    - installing on Windows 74
    - installing with FreeBSD 71
    - installing with Linux 62, 63
    - installing with VMWare 67, 68
    - installing with Windows 61
- E**
- electrostatic discharge 147
  - end devices 89
  - event log 114
  - expander connections 93
  - expander devices 89
  - external devices 53
- F**
- failed disk drives 85
    - multiple arrays 85
    - multiple disk drives 86
    - RAID 0 arrays 86
    - without hot spare 85
  - firmware 116
    - creating floppy disks 117
  - firmware upgrades 19
  - flashing controllers 86
  - floppy disks for firmware update 117
  - formatting disk drives 113
  - FreeBSD



driver installation 78  
OS installation 71

## H

hard disk, hard disk drive, hard drive. *See* disk drive  
HDA mode 86  
HDA mode jumper 86  
hot spares 18  
hybrid RAID 18, 52

## I

I2C connector specifications 122  
initializing disk drives 108  
installation  
  backplane 51  
  controllers 47  
  creating a driver disk 60  
  direct-attach 50  
  disk drives 50  
  driver 72 to 78  
  driver and FreeBSD 71  
  driver and Linux 62, 63  
  driver and operating system 59  
  driver and VMWare 67, 68  
  driver and Windows 61  
  existing operating system 45  
  external devices 53  
  installation options 45  
  solid state drives 52 to 53  
  with operating system 45

## K

kit contents 15

## L

LED connector specifications 122  
LED Indication Mode 111  
Linux  
  OS installation 63  
Linux installation 62  
low-profile bracket 15  
  installing 43, 44  
low-profile computer cabinet 40, 43, 47

## M

maxCache cache settings 105  
maxCache pool 109  
maxCache Solid State Drive  
  failed 86

  installing 52 to 53  
mini-SAS  
  direct connection 50  
  enclosure cable 42  
  internal cable 42  
  overview 91  
  SAS to SATA cable 42, 43  
mirroring 41  
mode 0 flash 86

## N

NCQ 18  
non-redundant arrays 96

## O

online expansion 18  
operating system installation 59  
operating systems 15

## P

parity 41  
Phy Rate setting 113  
phys 90  
Physical Drives Display During POST setting 111

## R

RAID 19  
  non-redundant arrays 96  
  RAID 0 96  
  RAID 1 97  
  RAID 10 98  
  RAID 1E 19, 97  
  RAID 5 99  
  RAID 50 101  
  RAID 5EE 19, 100  
  RAID 6 19, 102  
  RAID 60 19, 102  
RAID controllers. *See* controllers  
RAID levels 41  
recovering from disk drive failure 85  
Red Hat  
  OS installation 62  
Redundant Array of Independent Disks. *See* RAID  
Remote ARCCONF 18, 80, 82  
Removable Media Devices Boot Support setting 111  
replacing failed disk drives 85  
requirements 15  
  drive 42  
rescanning disk drives 108

resetting controllers 86  
Runtime BIOS setting 111

## S

safety information 147  
SAS  
  4-wide ports 91  
  backplane connections 92  
  cables 42  
  comparison to parallel SCSI 94  
  connectors 91  
  description 89  
  direct-attach connections 92  
  disk drives 92  
  edge expanders 93  
  end devices 89  
  expander connections 93  
  expander devices 89  
  fanout expanders 93  
  link speed 89  
  links 90  
  narrow connectors 91  
  narrow ports 91  
  phys 90  
  ports 90, 91  
  SAS address 91  
  SAS cards 89  
  SAS devices 89  
  SAS domain 93  
  terminology 89  
  transceivers 90  
  wide connectors 91  
  wide ports 91  
SAS Address setting 113  
SAS devices 89  
SAS disk drive identifiers 92  
secure erasing disk drives 108  
  stopping a secure erase 108  
Selectable Performance Mode 112  
Serial Attached SCSI. *See* SAS  
SerialSelect 110  
  applying changes 110  
  exiting 110  
  modifying controller settings 110  
  opening 110  
software 80  
Solaris  
  driver installation 76  
Solid State Drive (SSD) 18, 42, 50  
  installing 52 to 53  
specifications 148

storage management  
  Adaptec RAID Configuration utility 81  
  Adaptec Storage Manager 80  
  AFU 81  
  ARCCONF 80  
storage space 13  
support, customer 3  
SUSE installation 63  
system requirements 15

## T

technical specifications 148  
technical support 3  
Technical Support Identification (TSID) number 3  
terminology 13  
  SAS 89  
tools  
  Adaptec RAID Configuration utility 81  
  Adaptec Storage Manager 80  
  AFU 81  
  ARCCONF 80  
troubleshooting tips 83  
TSID Number  
  *See* Technical Support Identification Number

## U

updating firmware 116  
upgrading firmware 19  
utilities  
  Adaptec RAID Controller utility 81  
  AFU 81  
  ARCCONF 80

## V

verifying disk drives 113  
VMWare  
  OS installation 67, 68

## W

Windows  
  driver installation 74  
  OS installation 61

## Z

zero maintenance cache protection 18, 47, 48



PMC-Sierra, Inc.  
1380 Bordeaux Drive  
Sunnyvale, CA 94089 USA

© Copyright PMC-Sierra, Inc. 2011  
All rights reserved. Adaptec and the Adaptec by PMC logo  
are trademarks of PMC-Sierra, Inc.

Part Number: CDP-00268-01-A Rev. A