



PE210G2BPI40-T

Dual port Copper 10 Gigabit Ethernet PCI Express Bypass Server Intel® x540 Based

Product Description

Silicom's dual port Copper 10 Gigabit Ethernet Bypass server adapter is a PCI-Express X8 network interface card that contains two Copper 10 Gigabit Ethernet (10GBase-T) ports on a PCI-E adapter.



The Silicom's dual port Copper 10 Gigabit Ethernet Bypass server adapter is targeted to inline network system that maintains network connectivity when system fails. Silicom's dual port Copper 10Gigabit Ethernet Bypass server adapter supports Normal, Bypass and Disconnect* modes.

In Normal mode, the ports are independent interfaces. In Bypass mode, all packets received from one port are transmitted to the adjacent port.

In Disconnect* mode, the adapter simulates switch / rout cable Disconnection*. Silicom's dual port Copper 10Gigabit Ethernet Bypass server adapter can Bypass or Disconnect* its Ethernet ports on a host system failure, power off, or upon software request.

In Bypass mode, the connections of the Ethernet ports are Disconnected* from the system and switched over to the other port to create a crossed connection loop-back between the Ethernet ports.

Hence, in bypass mode all packets received from one port are transmitted to the adjacent port and vice versa. This feature enables to bypass a failed system and provides maximum up time for the network.

Silicom's dual port Copper 10Gigabit Ethernet Bypass server adapter includes an on board WDT (Watch Dog Timer) controller.

The adapter's software drivers or software application can write commands to the on board WDT controller. The adapter's software drivers, WDT controller and the Bypass circuitry provide an interface that control and manage the mode of the adapter.



Silicom's dual port Copper 10Gigabit Ethernet Bypass server adapters is based on Intel x540 Dual port 10GBase-T Ethernet controller.

Key Features

Bypass / Disconnect*:

- Bypass / Disconnect* Ethernet ports on Power Fail, System Hangs or Software Application Hangs.
- Software programmable Bypass, Disconnect or Normal Mode
- On Board Watch Dog Timer (WDT) Controller
- Software programmable time out interval
- Software Programmable WDT Enable / Disable counter
- Software programmable Bypass Capability Enable / Disable
- Software Programmable Disconnect* Capability Enable / Disable
- Software Programmable mode Bypass, Normal or Disconnect* mode at Power up
- Software Programmable mode Bypass, Normal mode) at Power off
- Independent Bypass operation in every two ports
- Emulates standard NIC

Copper 10 Gigabit Ethernet 10GBASE-T :

- Integrated 10 Gigabit Copper PHY supports 10GBASE-T, 1000 BASE- T and 100BASE- TX
- Triple speed 10Gbps (10GBase-T), 1000Mbps (1000Base-T) and 100 Mbps (100Base-Tx)
- RJ-45 connector supports CAT 6A cable

Performance Features:

- Support for jumbo frame up to 15.5KB
- Flow control support
- Statistics management and RMON
- 802.1q VLAN support
- TCP segmentation offload: up to 256KB
- IPV6 Supports for IP/ TCP and IP/UDP Receive Checksum offload
- Fragmented UDP checksum offload for Packet Reassembly
- Message Signal interrupts (MSI)
- Message Signal interrupts (MSI-X)
- Interrupt throttling control to limit maximum interrupt rate and improve CPU usage
- Multiple Receive Queues (RSs) 8x8 & 16x4
- 32 Transmit queues
- Support for 16 Virtual Device Queues (VMDq) per port
- Support Direct Cache Access (DCA)

- Large on chip receive packet buffer (384 KB)
- Large on chip transmit packet buffer (160KB)

Host Interface:

- PCI Express X8 lanes
- Support PCI Express Base Specification 2.1 (5GT/s)

Technical Specifications

Bypass Specifications	
WDT Interval (Software Programmable):	3,276,800 mSec (3,276.8 Sec): Maximum 100 mSec (0.1 Sec) : Minimum WDT Interval = (2 ^{wdt_interval_parameter})*(0.1) sec. wdt_interval_parameter: { Valid Range: 0-15}
10GBASE-T Copper Ethernet Adapters Technical Specifications	
IEEE Standard / Network topology:	Copper 10Gigabit Ethernet, 10GBASE-T, IEEE 802.3an Gigabit Ethernet, 1000Base-T 100 Mb Ethernet: 100BASE- TX
Data Transfer Rate:	20 Gb/s, 2000Mb/s and 200 Mb/s in full duplex mode per port
Cables and Operating distance:	100Base-Tx Category 5 maximum 50m * 1000Base-T Category 5E maximum 50m * 10GBase-T Category 6A maximum 50m ** *Theoretical Distance – Defined as half a distance as stated by the IEEE 802.3-2005 standard **Theoretical Distance – Defined as half a distance as stated by the IEEE 802.3an standard
Operating Systems Support	
Operating system support:	Linux
General Technical Specifications	
Interface Standard:	PCI-Express Base Specification Revision 2.1 (5GT/s)
Board Size:	Low profile add-in card: 167.65mm X 68.91mm (6.60"X 2.713")
PCI Express Card Type:	X8 Lane

PCI Express Voltage:	+12V +- 8%
PCI Connector:	Gold Finger: X8 Lane
Controller:	Intel x540
Holder:	Metal Bracket
I/O:	RJ45
Weight:	170 gr (5.997 oz)
Power Consumption:	13.56W, 1.13A at 12V: Typical all ports operate at 10Gb/s, (Normal Mode). 8.04W, 0.67A at 12V: Typical all ports operate at 1Gb/s, (Normal Mode). 5.28W, 0.44A at 12V: Typical all ports operate at 100Mb/s, (Normal Mode). 7.2W, 0.6A at 12V: Typical Bypass Mode. 7.44W, 0.62A at 12V: Typical Disconnect Mode. 7.56W, 0.63A at 12V: Typical No link at all ports
Operating Humidity:	0%–90%, non-condensing
Operating Temperature:	0°C – 45°C (32°F – 113°F) Air flow requirement for this adapter is 200 LFM
Storage:	-40°C–65°C (-40°F–149°F)
EMC Certifications:	EN 55022: 2010, Class B Conducted disturbance at mains terminals Conducted disturbance at telecommunication port Radiated disturbance EN 61000-3-2: 2006+A1(09)+A2(09) Harmonic current emissions EN 61000-3-3: 2008 Voltage fluctuations and flicker EN 55024: 2010 Immunity to electrostatic discharge (ESD) Radiated immunity to radio frequency electromagnetic field Conducted immunity to electrical fast transients / bursts (EFT/ B) Conducted immunity to voltage surges Conducted immunity to disturbances induced by radio frequency field Conducted immunity to voltage dips and short interruptions

MTBF*:	151 (Years) *According to Telcordia SR-332 Issue 2 Environmental condition – GB (Ground, Fixed, Controlled). Ambient temperature – 40°C.
LEDs	
LEDs:	(2) LED per port Lower (Right) LED: Link /ACT : Turns on link , blinks on activity (Green) Upper (Left) LED: Speed / Bypass / Disconnect* Link of 1Gb/s: Turns on link (Yellow) Link of 10Gb/s: Turns on link (Green) Bypass: Blink (Green) on Bypass Disconnect* : Blink (Yellow)
LEDs location:	LEDs are located in the RJ45 connector port
Connectors:	(2) Shielded RJ-45

Functional Description

Silicom's Bypass Server adapters support Normal, Bypass and Disconnect modes.

In Normal mode, the ports are independent interfaces (see Figure 1: Normal mode, one Bypass pair is illustrated).

Figure 1: Normal Mode Functional Block Diagram

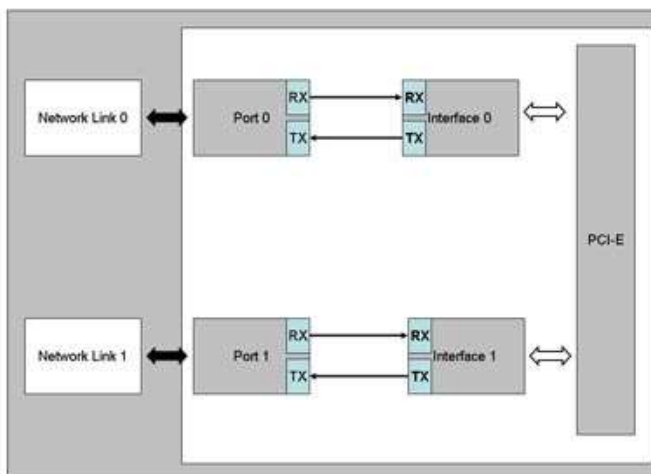

In Bypass mode, the connections of the Ethernet network ports are Disconnected from the interfaces and switched over to the other port to create a crossed connection loop-back between the Ethernet ports. The connections of the interfaces are left not connected. (See Figure 2: one Bypass pair illustrated)

Figure 2: Bypass Mode Functional Block Diagram

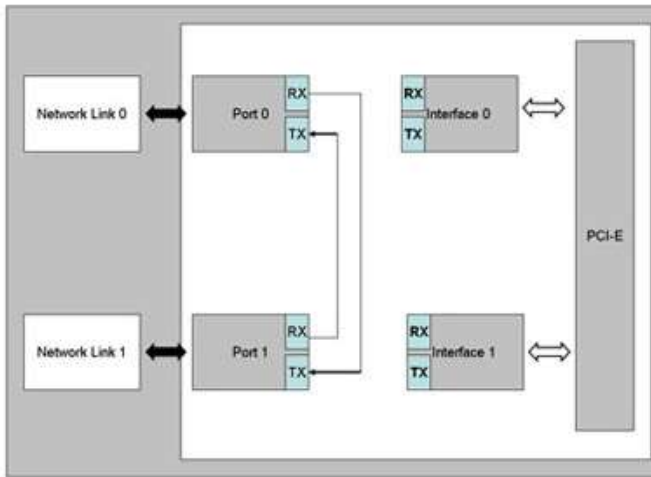

In Disconnect mode, the transmit connections of the Ethernet network ports are Disconnected from the interfaces. (See Figure 3: one Bypass pair illustrated)

Figure 3: Disconnect Mode Functional Block Diagram

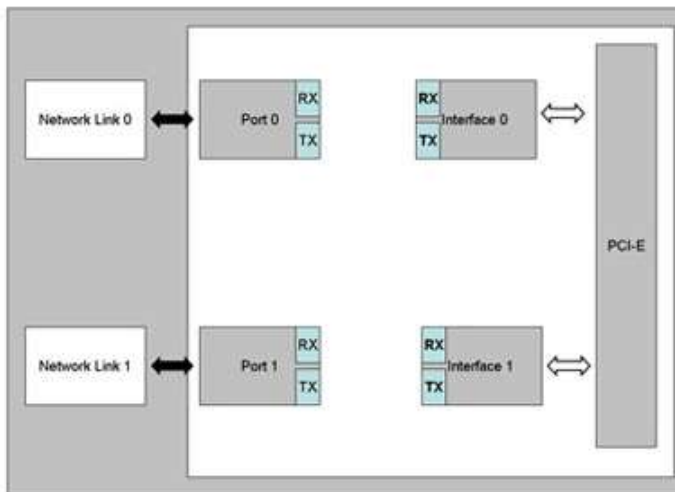

Silicom Bypass server adapters include an on board Controller that can Bypass the Ethernet ports on host system failure like Power Off, System hangs or software application hangs. The software programmable Watch Dog Timer (WDT) Controller detects a host system fails and it will Bypass automatically the Ethernet ports after programmable time out interval. The WDT Controller can be software programmable enabled or disabled.

Silicom Bypass server adapters support software programmable to select Bypass or Normal mode. In Normal mode, the ports of the adapters remain independently operational.

The drivers of the adapters and the Bypass circuitry provides an interface that control and management the mode of the adapter. The adapter software driver or software application can writes commands to the on board controller. The on board controller processes the commands and activates the bypass circuitry accordingly.

After power up the default mode of the adapter is to be in Bypass mode. After driver is loaded, the adapter software driver or application can set the card to a Normal mode. After the Host system issues reset, setting of Bypass controller and circuitry are reserved.

Silicom Bypass server adapters support Disable Bypass Capability; hence, if those adapters receive Disable Bypass Capability command, the adapter does not Bypass its Ethernet ports, in this state the four Ethernet ports are independent. The Disable Bypass Capability state is reserved also after power off. This feature enables to emulate a standard NIC.

Silicom Bypass server adapters can be set to Bypass or Normal mode at power up. This setting programmable and is reserved also after power off.

Order Information

P/N	Description	Notes
PE210G2BPI40-T-SD	Dual Port Copper 10 Gigabit Ethernet PCI Express Bypass Server Adapter	X8 Gen 2.1, Based on Intel X540, RoHS compliant, short, low-profile

1V4