



# SNR-RE-G4

## User Manual

## Foreword

This manual is the product technical manual for the SR201-G2 2U rack-mounted server, primarily providing an introduction and explanation of the product's appearance, structure, hardware installation, and basic configurations. This manual is intended for reference and research by professional technical personnel. The installation and maintenance of this product should be carried out only by experienced technical personnel.

### Symbol Conventions:

 **Caution:** Used to convey equipment or environmental safety warning messages. Failure to avoid these warnings may result in equipment damage, data loss, reduced equipment performance, or other unforeseeable consequences.

 **Warning:** Used to alert to potential danger situations. Failure to avoid these warnings may result in personal injury or serious bodily harm.

 **Red Arrow:** Represents pointing to a specific location.

 **Blue Arrow:** Represents the action of pulling out, inserting, or tilting the insertion.

 **Hollow Arrow:** Represents the next step in the action or result.

 **Blue Rotating Arrow 1:** Represents the action of clockwise turning of screws or pulling outward.

 **Deep Blue Rotating Arrow 2:** Represents the action of counterclockwise turning of screws or fastening inward.

## Contents

Foreword.....	2
1. Product Introduction.....	5
1.1 Product overview.....	5
1.2 Product structure.....	7
1.3 Logical structure.....	8
1.4 Product specifications .....	9
SNR 2U rackmount server .....	9
2. Hardware Description .....	10
2.1 Front panel .....	10
2.1.1 Appearance .....	10
2.1.2 Indicator lights and buttons.....	12
2.1.3 Interface.....	14
2.2 Rear panel .....	15
2.2.1 Appearance.....	15
2.2.2 Indicator lights and buttons.....	15
2.2.3 Interface .....	16
2.3 Processor .....	17
2.4 Memory .....	18
2.4.1 Memory slot location .....	18
2.4.2 Memory compatibility information .....	18
2.5 Storage.....	19
2.5.1 Hard drive configuration.....	19
2.5.2 Hard drive sequence number.....	20
2.5.3 Hard drive status indicator.....	21
2.6 Power supply .....	22
2.6.1 Fan.....	22
2.7 I/O expansion.....	23
2.7.1 PCIe slot distribution .....	23
2.7.2 PCIe slot description .....	24
2.7.3 PCIe expansion module.....	25
2.8 PCBA.....	27
2.8.1 Motherboard.....	27
2.8.2 Hard drive backplane .....	28
3. Installation Instructions .....	32
3.1 Chassis top cover installation .....	32
3.2 Installation of accessories .....	32
3.2.1 Installation of CPU .....	32
2. Flip open the CPU cover.....	32
3.2.2 Installation of heatsink .....	34
3.2.3 Installation of memory .....	35
3.2.4 Installation of server slide rail .....	36
4. Configuration Instructions .....	39
4.1 Initial configuration .....	39
4.1.1 Power on the system .....	39

---

4.1.2 Initial data .....	41
4.1.3 Configuration of BIOS.....	41
4.1.4 Configuration of BMC.....	42
With the server in the powered-on state, ensure that the BMC dedicated management network cable is properly connected. Use another device within the same local network to enter the IP address into a web browser. The login interface will appear as shown below: .....	42
After entering the account and password, you can access the homepage. You can set the BMC IP address in the management interface. On the left side of the interface, switch to 'Settings' -> 'Network Settings' -> 'Network IP Settings' as shown in the following image: .....	42
In the powered-on state of the server, ensure that the dedicated management network cable for BMC is connected properly. ....	43
Using another device, ensure that it is on the same local network as the BMC management network. Enter the BMC IP address into a web browser to access the BMC interface. ....	43
The method to check the BMC IP address is as follows: .....	43
Appendix.....	46
<b>Front Panel Indicator Lights Alarm</b> .....	46
<b>IPMI Connection Failure</b> .....	47

## 1. Product Introduction

### 1.1 Product overview

The SNR-RE-G4 2U rack-mounted server is a versatile dual-socket server introduced by SNR based on the AMD Genoa platform. It is designed to meet the demands of various applications, including the internet, IDC (Internet Data Center), cloud computing, enterprise markets, and telecommunications services. It is suitable for core IT operations, cloud computing, virtualization, high-performance computing, distributed storage, big data processing, enterprise, or telecommunications applications, and other complex workloads. This server offers advantages such as versatility, low energy consumption, strong expansion capabilities, high reliability, easy management, and easy deployment.

The main features of the product include:

- Support for two high-performance AMD EPYC 9004 series processors.
- Support for 24 DDR5 memory slots, with a maximum capacity of 6TB of memory.
- Support for three types of chassis: ① 8/3.5-inch hard drive chassis; ② 12/3.5-inch hard drive chassis; ③ 25/2.5-inch hard drive chassis.
- Rear window supports expansion for 4/3.5-inch hard drive slots or 4/2.5-inch hard drives.
- Support for up to 11 PCIe expansion slots(including OCP3.0), which can accommodate 2 double-width full-height full-length GPU cards.



① SNR-SR2408RE (Figure 1-1)



② SNR-SR2412RE (Figure 1-2)



③ SNR-SR2425RE (Figure 1-3)



11 PCIe expansion rear window (Figure 1-4)

## 1.2 Product structure

The physical structure of the SNR-RE-G4 2U rack-mounted server may vary depending on specific requirements. Taking the SNR-SR2412RE model as an example, the various components of the server are described as shown in the following figure:

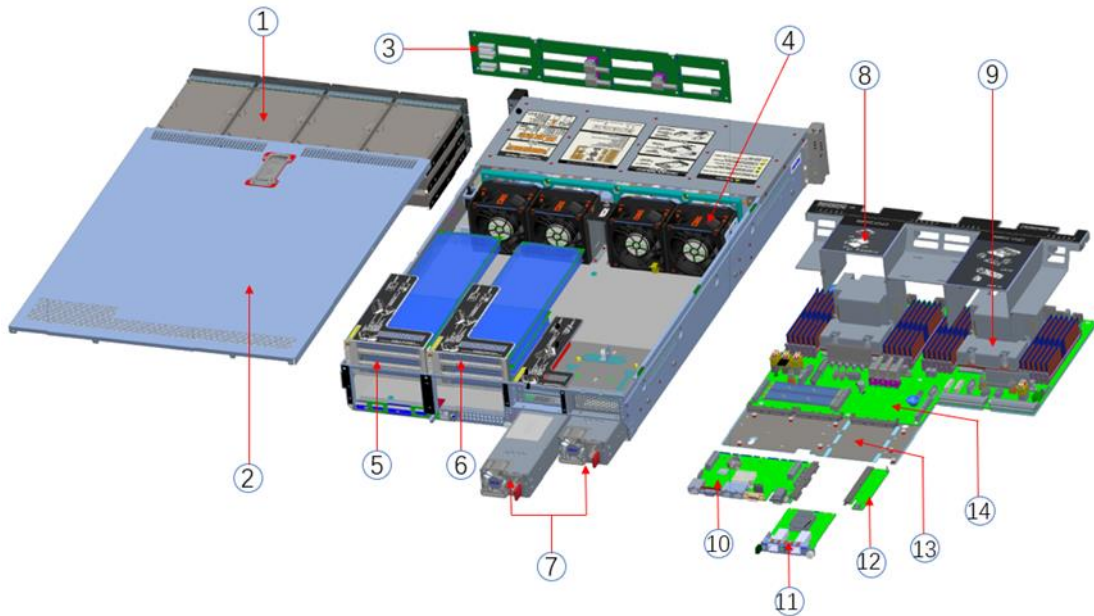

Structure Diagram (1-5)

No.	Name	No.	Name
1	Hard Drive Module	8	Air Guide Cover
2	Chassis Top Cover	9	2U CPU Heatsink
3	2U12 Hard Drive Backplane	10	BMC Board
4	Fan Module	11	OCP 3.0 Network Card
5	PCIe Expansion Module 1	12	Switch Board
6	PCIe Expansion Module 2	13	Motherboard Bracket
7	Redundant Power Supply Module	14	Motherboard (G2DLRO-B)

Table (1-1)

## 1.3 Logical structure

The logic of the SNR-RE-G4 2U rack server is as shown in the following diagram:

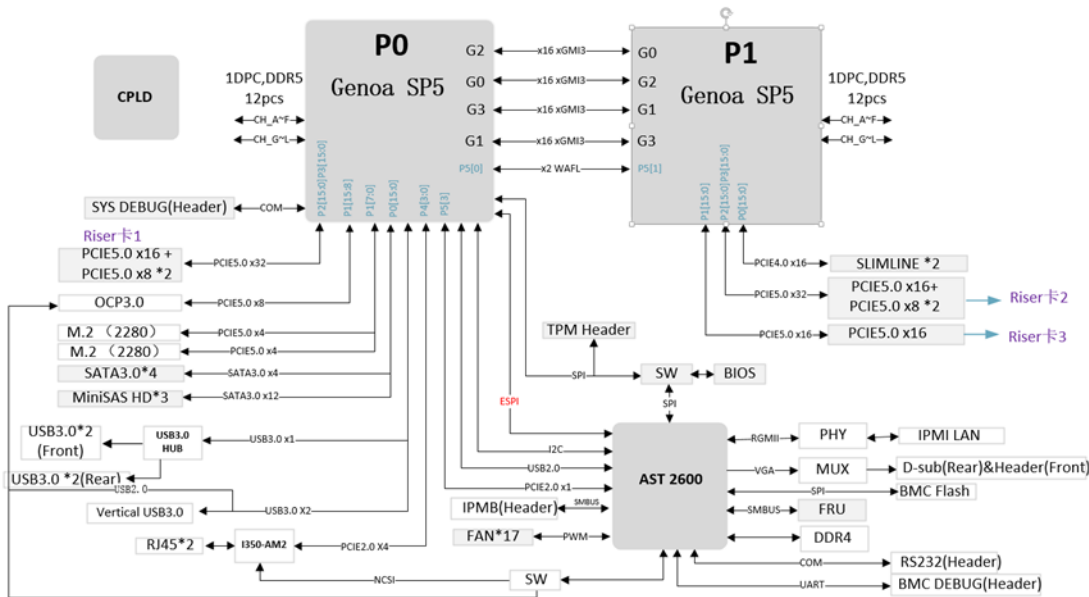

Motherboard logic block diagram (1-6)

- 2 SP5 Sockets, supporting 2 AMD EPYC™ 9004 series processors.
- A single CPU supports 12 DDR5 channels, and two CPUs together support 24 DIMM DDR5 memory slots.
- On the motherboard, there are 3 sets of PCIe Riser slots. Specifically, RISER1 has 32 PCIe 5.0 lanes from CPU0, RISER2 has 32 PCIe 5.0 lanes from CPU1, and RISER3 has 16 PCIe 5.0 lanes from CPU1.
- The G2DLRO-B motherboard provides 2 M.2 Key M SSD slots, supporting only 2280-size/22110-size SSDs with PCIe 4.0 x4 signals.
- The motherboard integrates 2 Gigabit Ethernet ports using the I350-AM2 chip.
- The BMC board chip utilizes ASPEED's AST2600 control chip for IPMI remote management, VGA output, and a dedicated Gigabit RJ45 management network port.



## 1.4 Product specifications

System			
System Model	SNR-SR2408RE	SNR-SR2412RE	SNR-SR2425RE
Chassis	SNR 2U rackmount server		
Motherboard	G2DLRO—B		
CPU	Supports 2 AMD EPYC™ 9004 processors		
Memory	Supports DDR5-4800/4400MHz RDIMM/LRDIMM memory; supports a single capacity of 8G/16GB/32GB/64GB/128GB/256GB, and the entire machine supports a maximum memory capacity of 6TB.		
Hard Drive	Supports 8 hot-swappable 3.5 or 2.5-inch hard drives in the front	Supports 12 hot-swappable 2.5-inch hard drives in the front	Supports 25 hot-swappable 2.5-inch hard drives in the front
	Supports 4 hot-swappable 3.5-inch or 4 hot-swappable 2.5-inch hard drives in the rear		
Network Function	Supports 2 RJ45 Gigabit Ethernet ports.		
Management Port	1 RJ45 IPMI management port.		
Display Function	Onboard Aspeed® AST2600 chip for VGA output.		
M.2	Supports 2 M.2 interfaces (M key, supports 2280-size/22110-size specifications).		
USB	2 front USB 3.0 ports, 1 internal USB 3.0 port, and rear USB 3.0 ports.		
Expansion Slot	Supports a maximum of 11 PCIe expansion slots (including OCP3.0).		
Power Supply	System supports 800W, 1200W, 1300W, 1600W, 2200W hot-swappable redundant power supplies.		
Fan	System supports 4*8038 temperature-controlled fans (optional 8056 temperature-controlled fans).		
Size	748mm*433.4mm*87.6mm (length*width*height)		
Operating System Support			
Supported Operating Systems	CentOS 7.6/ CentOS 8.0		
	SLES11 SP4 Ubuntu 17.04/Ubuntu 18.04/ Ubuntu 20.04 Windows server 2016/Windows server 2019 VMware ESXi vSphere6/VMware ESXi vSphere7		
System Environmental Parameters			
Working Temperature and Humidity	Temperature 5°C~35°C; Humidity: 35%~80% non-condensing		
Storage Temperature and Humidity	Short time (≤72H): Temperature -40°C~70°C/Humidity 20%~90% non-condensing (including packaging) Long time (>72H): Temperature 20°C~28°C/Humidity 30%~70% non-condensing (including packaging) including packaging)		
Certification			
Certification	CE CCC ROHS		

Table (1-2)

## 2. Hardware Description

### 2.1 Front panel

#### 2.1.1 Appearance

- 8x3.5 inch hard drive configuration

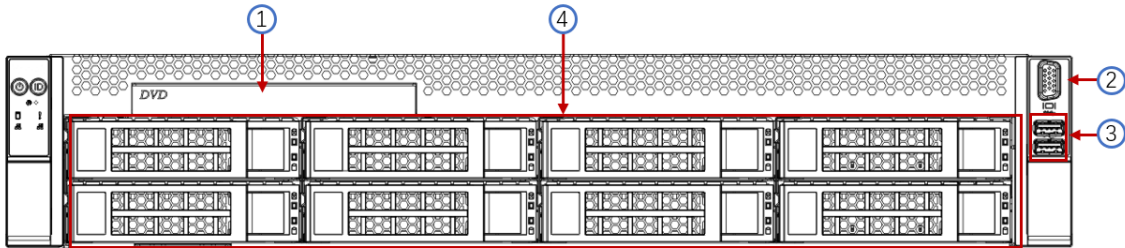

Figure (2-1)

No.	Name	No.	Name
1	DVD drive (optional)	3	USB3.0 interface
2	VGA interface	4	3.5 inch hard drive

table (2-1)

- 12x3.5 inch hard drive configuration

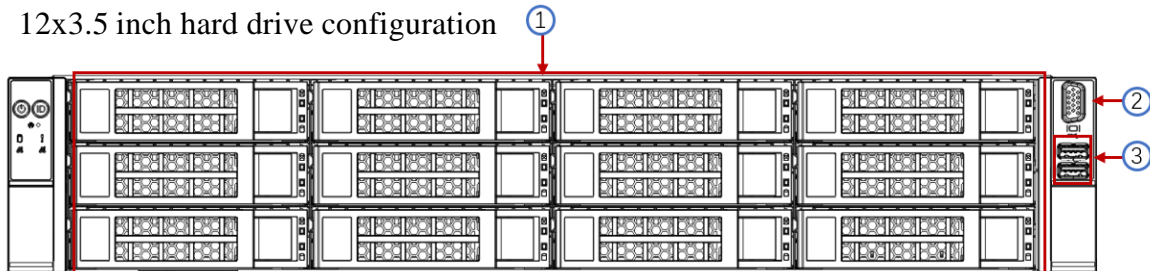

Figure (2-2)

No.	Name	No.	Name
1	3.5 inch hard drive	3	USB 3.0 interface
2	VGA interface		

table (2-2)

- 25x2.5 inch hard drive configuration

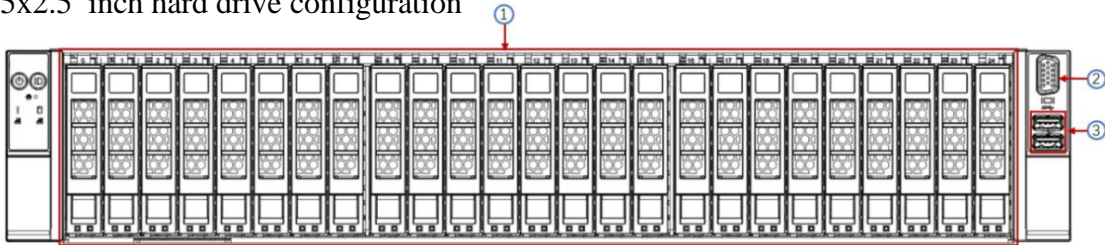

Figure (2-3)

No.	Name	No.	Name
1	2.5 inch hard drive	3	USB3.0 interface
2	VGA interface		

table (2-3)

## 2.1.2 Indicator lights and buttons

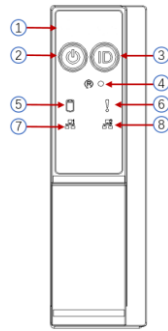



Figure (2-4)

No.	Indicator light /button	No.	Indicator light /button
1	SNR logo	5	Hard drive indicator
2	Power switch button/indicator	6	System Alarm Indicator
3	UID button/indicator	7	Network port 1 connection status indicator
4	Restart button	8	Network port 2 connection status indicator
LED status description			
logo	Indicator light /button	status description	
	Power indicator	<p>Description of the power indicator light:</p> <p>Green (steady on): Indicates that the device has been powered on normally.</p> <p>Green (blinking): Indicates that the device is in standby.</p> <p>Green off: Indicates that the device is not powered on.</p> <p>Power button description:</p> <p>Press the button briefly in the power-on state to turn off the OS normally.</p> <p>Press and hold the button for 6 seconds in the power-on state to force the server to Power off.</p> <p>Short pressing this button while the system is in standby mode will power on the device.</p>	
	UID button/indicator	<p>UID button/indicator light is used for conveniently locating the server to be operated. It can be manually activated by pressing the UID button or controlled remotely via BMC commands to turn the light on or off.</p> <p>UID Indicator Light Explanation:</p> <p>Blue (steady/flashing): Indicates that the server is being located.</p>	





		<p>Off: Indicates that the server is not being located.</p> <p>UID Button Explanation: A short press of this button can turn the locator light on/off.</p>
	Restart button	Press to restart the server
	Hard drive indicator	Blinking green light: The hard drive is operating normally
	System warning indicator	System warning indicator. Including system alarms, fan alarms, power supply alarms, etc., which can be viewed through the IPMI management software.
	Network port connection status indicator	<p>The Ethernet port indicator lights correspond to the network card slots.</p> <p>Green (steady on): indicates that the network port is connected normally.</p> <p>Off: indicates that the network port is not in use or faulty.</p> <p>Note: associated with the two 1GE ports on the motherboard.</p>
	Network port connection status indicator	<p>The Ethernet port indicator lights correspond to the network card slots.</p> <p>Green (steady on): indicates that the network port is connected normally.</p> <p>Off: indicates that the network port is not in use or faulty.</p> <p>Note: associated with the two 1GE ports on the motherboard.</p>

Table (2-4)

## 2.1.3 Interface

- Interface location

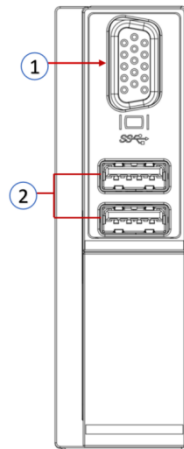

Figure 2-5

No.	Name	No.	Name
1	VGA interface	2	USB 3.0 interface

Table 2-5

- Interface description

Name	Type	Quantity	Description
VGA interface	DB15	1	Used for connecting display terminals, such as monitors or KVM
USB interface	USB 3.0	2	For accessing USB devices

Table 2-6

## 2.2 Rear panel

### 2.2.1 Appearance

- Appearance of the rear panel

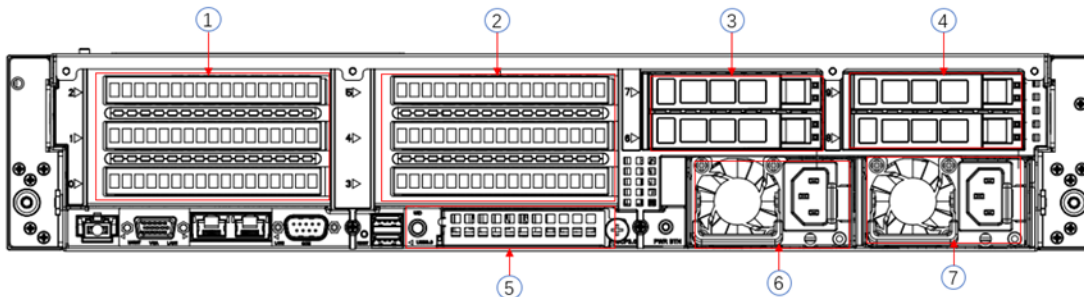

Figure (2-6)

No.	Name	No.	Name
1	Riser1 module	2	Riser2 module
3	Riser3 module	4	Riser4 module
5	OCP 3.0 network card (optional)	6	PSU1
7	PSU2	-	-

Table (2-7)

Note:

- 1. Riser1 module, Riser2 module, Riser3 module, Riser4 module can be optionally equipped with either rear-mounted hard drive module or PCIe riser module.
- 2. This diagram is for reference only; the actual configuration takes precedence.

### 2.2.2 Indicator lights and buttons

- Rear Panel Indicators

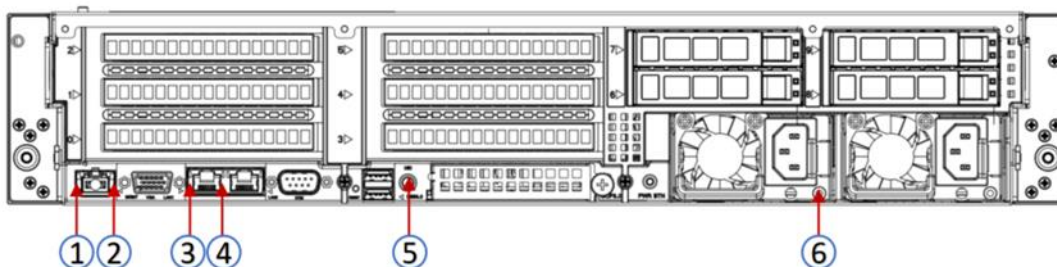

Figure (2-7)

No.	Name	No.	Name
1	Management port data transmission status indicator lights	2	Management port connection status indicator lights
3	Network port data transmission status indicator lights	4	Network port connection status indicator lights
5	Reset button	6	Power module indicator lights

Table (2-8)

### Description of Power Module Indicator

Indicator Light/ Button	Status Description
Power module indicator	<p>Green (steady on): Indicates that the input and output are normal.</p> <p>Yellow (steady on): Indicates that the AC power cord is unplugged or the power module is missing, and only one power module in parallel has AC input; power module malfunction causing output shutdown, such as OVP, OCP, fan failure.</p> <p>Green (1 Hz /flashing): Indicates that the input is normal, the voltage is too low (less than 12 V) or the power supply is in the smart open state.</p> <p>Green (2 Hz /flashing): Indicates that the Firmware is being upgraded online.</p> <p>Yellow (1 Hz /flashing): Power supply warning event indicating continuous power supply operation, high temperature, high power, high current.</p> <p>Off: Indicates no AC power input.</p>

Table (2-9)

### 2.2.3 Interface

- rear panel interface

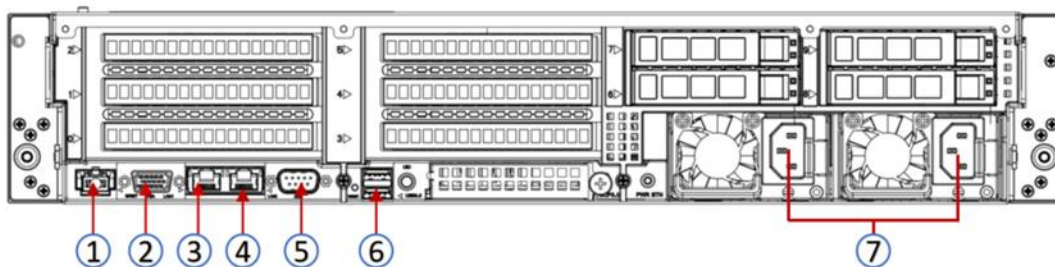

Figure (2-8)



No	Name	No.	Name
1	Management Network Port	2	VGA interface
3	Gigabit Network Port(Onboard Network Port 1)	4	Gigabit Network Port(Onboard Network Port 2)
5	COM interface	6	USB3.0 interface
7	Power Module interface	-	-

Table (2-10)

## 2.3 Processor

- Supports 2 AMD EPYC™ 9004 processors
- When configuring with a single processor, it must be installed in the CPU 0 socket
- If configuring processors in the same server, they must have the same model
- For specific available system options, please consult SNR sales
- Processor positions as shown in the diagram below:

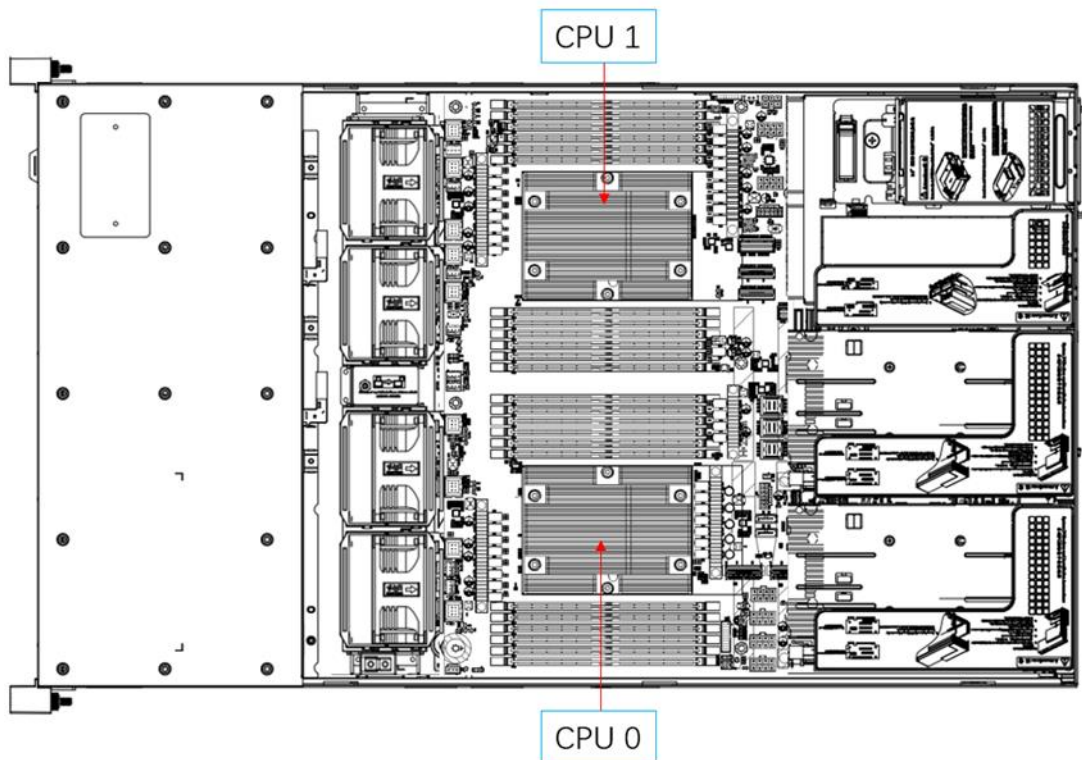

Figure (2-9)

## 2.4 Memory

### 2.4.1 Memory slot location

The motherboard supports 12 DDR5 channels, and 2 CPUs support a total of 24 DDR5 inserted memory slots

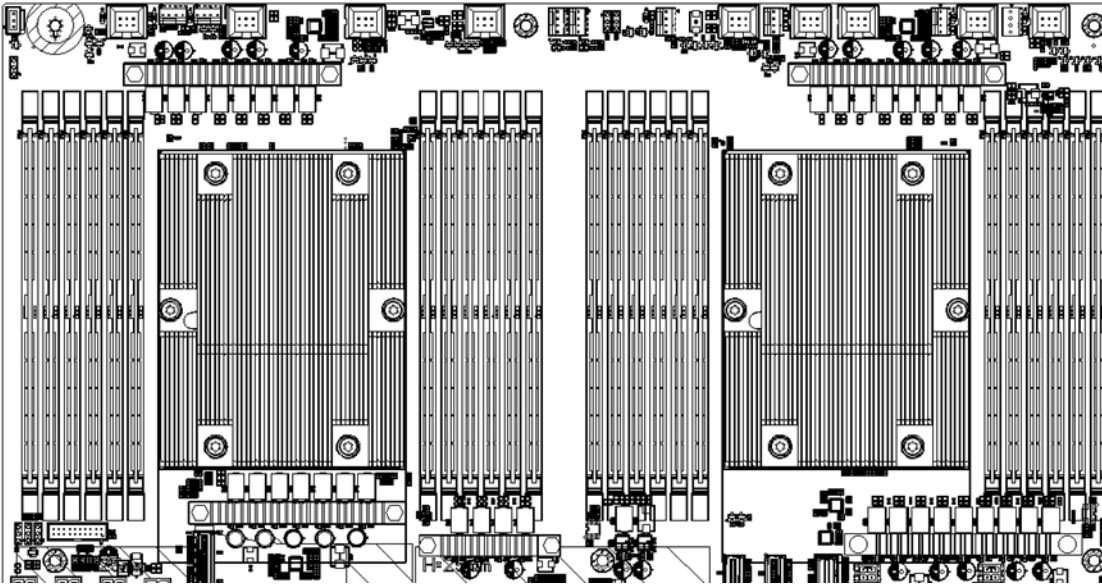

Figure (2-10)

### 2.4.2 Memory compatibility information

The motherboard supports DDR5 RDIMM/LRDIMM server memory, and the memory frequency supports 4800/5200MHz.

Note:

- The same server must use the same type of DDR5 memory, and all of the memory must run at the same speed, with the speed value being the lowest of the following:
  - Memory speed supported by a specific CPU. Maximum operating speed for a specific memory configuration.
- Mixing of different types (RDIMM, LRDIMM) and different specifications (capacity, bit width, rank, height, etc.) of DDR5 memory is not supported.
- The maximum memory capacity of AMD EPYC's different models of CPUs is different. (For details, see the attachment-AMD CPU memory installation guide)

Number of Memory Channels Populated	Recommended Memory Channels (UMC to Memory Channel Mapping)													Nodes per Socket (NPS) supported <sup>2</sup>
	Memory Channel	A	C	B	E	D	F	G	I	H	K	J	L	
12	Memory Channel	A	C	B	E	D	F	G	I	H	K	J	L	NPS4, NPS2, NPS1
	UMC instance	3	0	4	1	5	2	9	6	10	7	11	8	
10	Memory Channel	A	C	B	E	D		G	I	H	K	J		NPS2, NPS1
	UMC instance	3	0	4	1	5		9	6	10	7	11		
8	Memory Channel	A	C	B	E			G	I	H	K			NPS4, NPS2, NPS1
	UMC instance	3	0	4	1			9	6	10	7			
6	Memory Channel	A	C	B				G	I	H				NPS2, NPS1
	UMC instance	3	0	4				9	6	10				
4	Memory Channel	A	C					G	I					NPS4, NPS2, NPS1
	UMC instance	3	0					9	6					
2	Memory Channel	A						G						NPS2, NPS1
	UMC instance	3						9						
1	Memory Channel	A												NPS1
	UMC instance	3												

Figure (2-11)

## 2.5 Storage

### 2.5.1 Hard drive configuration

Configuration	Maximum number of front hard drives (pieces)	Maximum number of rear hard drives (pieces)	Description
Configuration 1 8x3.5-inch hard drive	Front hard drive supports eight 3.5-inch or 2.5-inch SAS/SATA hard drive	Riser1/2 module supports expansion of four 3.5-inch SAS/SATA hard drives. Riser3/4 module supports the expansion of four 2.5-inch NVMe/SAS/SATA hard drives.	SAS hard drives require optional SAS pass-through cards or RIAD cards.
Configuration 2 8x3.5-inch hard drive	Front hard drive supports eight 3.5-inch or 2.5-inch SAS/SATA/NVMe hard drive	Riser1/2 module supports expansion of four 3.5-inch SAS/SATA hard drives. Riser3/4 module supports the expansion of four 2.5-inch NVMe/SAS/SATA hard drives.	NVMe hard drives require a Retimer card. SAS hard drives require an optional SAS pass-through card or RIAD card.
Configuration 3 12x3.5-inch hard drive	Front hard drive supports 12*3.5-inch or 2.5-inch SAS/SATA hard drives	Riser1/2 module supports expansion of four 3.5-inch SAS/SATA hard drives. Riser3/4 module supports expansion of four 2.5-inch NVMe/SAS/SATA hard drives.	SAS hard drives require optional SAS pass-through card or RIAD card support.

Configuration 4 12x3.5-inch hard drive	Front hard drive supports 12*3.5-inch or 2.5-inch SAS/SATA/NVMe hard drive	Riser1/2 module supports expansion of four 3.5-inch SAS/SATA hard drives. Riser3/4 module supports the expansion of four 2.5-inch NVMe/SAS/SATA hard drives.	NVMe hard drives require a Retimer card. SAS hard drives require an optional SAS pass-through card or RIAD card.
Configuration 5 12x3.5-inch hard drive	Front hard drive supports 12*3.5-inch or 2.5-inch SAS/SATA hard drives	Riser1/2 module supports expansion of four 3.5-inch SAS/SATA hard drives. Riser3/4 module supports expansion of four 2.5-inch NVMe/SAS/SATA hard drives.	Requires optional SAS pass-through card or RIAD card support.
Configuration 6 25x2.5-inch hard drive	Front hard drive supports 25*2.5-inch SAS/SATA hard drives	Riser1/2 module supports expansion of four 3.5-inch SAS/SATA hard drives. Riser3/4 module supports expansion of four 2.5-inch NVMe/SAS/SATA hard drives.	Requires optional SAS pass-through card or RIAD card support.

Note: \*Maximum number of rear hard drives is affected by NVMe/SAS/SATA hard drive type.

Table (2-10)

## 2.5.2 Hard drive sequence number

### 8x3.5-inch hard drive configuration

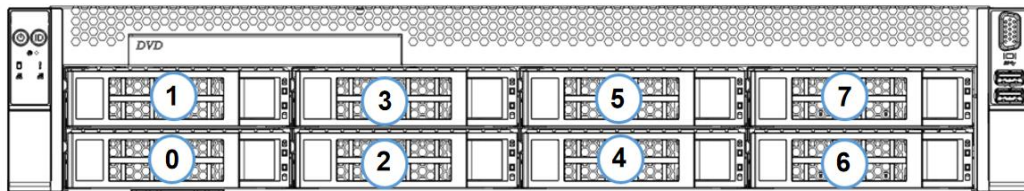

Figure (2-11)

### 12x3.5-inch hard drive configuration

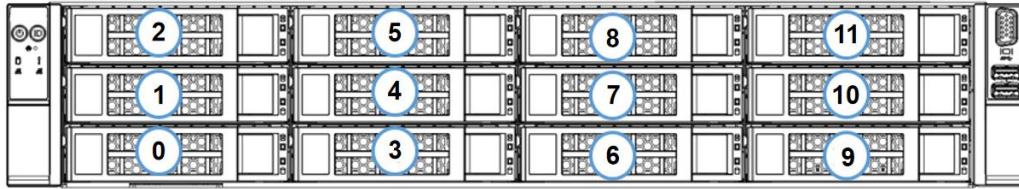

Figure (2-12)

### 25x2.5-inch hard drive configuration

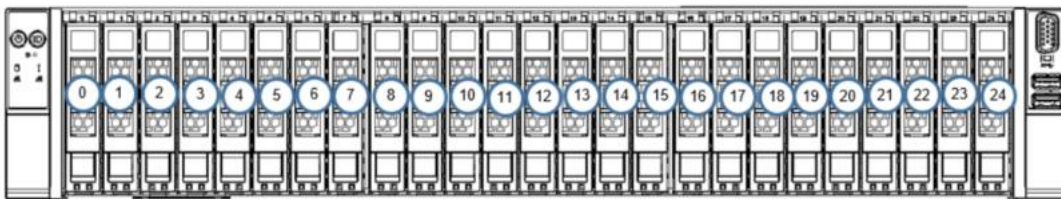

Figure (2-13)

### 2.5.3 Hard drive status indicator

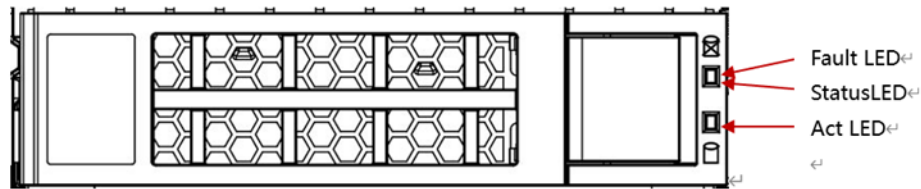

Figure (2-14)

- Hard drive status indicator description

Function	Act LED	Status LED	Fault LED
Hard drive in position	always on	OFF	OFF
Hard drive activity	always on	OFF	OFF
Hard drive location	always on	Blinking 4Hz/second	OFF
Hard drive error	always on	OFF	always on
RAID rebuild	always on	OFF	Blinking 1Hz/second

Table (2-11)

## 2.6 Power supply

- Support 1 or 2 power modules
- Support AC or DC power modules
- Support hot swap
- When configuring 2 power modules, it supports 1+1 redundancy
- For the server's power modules, the power module models must be the same
- For specific optional system components available for purchase, please consult SNR sales
- The power supply location is shown in the figure below:

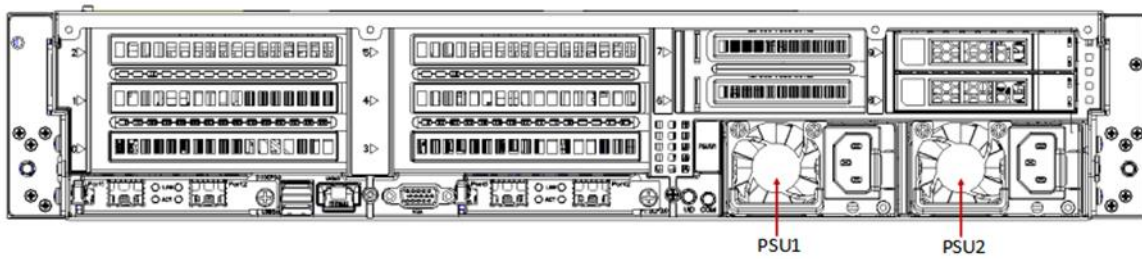

Figure (2-15)

### 2.6.1 Fan

- Support 4 fan modules
- Support hot swap
- Support single fan failure
- Support variable fan speed
- For fan modules configured in the same server, the fan module models must be the same
- The fan position is shown in the figure below:

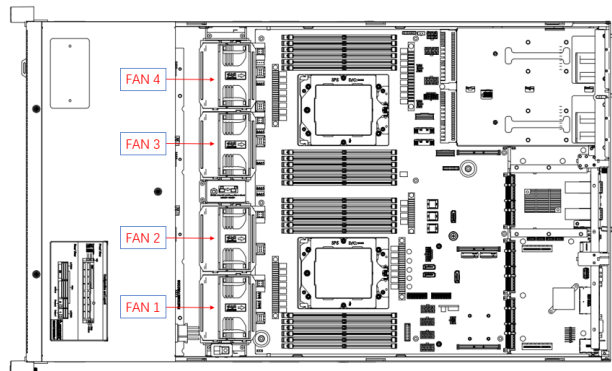

Figure (2-16)

## 2.7 I/O expansion

### 2.7.1 PCIe slot distribution

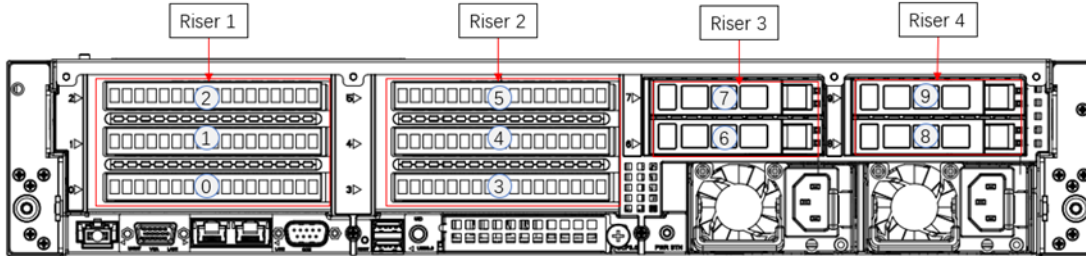

Figure (2-17)

Riser 1 provides slots slot 0-2. Riser 2 provides slots Slot3-5. Riser3 provides slots Slot6-7. Riser4 provides slots Slot8-9 (Riser modules support optional adapter cards 4.0/5.0).

Riser 1 optional configuration: Two 3.5-inch hard drive modules/PCIe full-height expansion modules (choose 1 out of 2):  
 When selecting the PCIe expansion module, Slot0 can accommodate either a PCIe X8 or PCIe X16 device, Slot1 can accommodate a PCIe X8 device, and Slot2 can accommodate a PCIe X16 device. When selecting the 3.5-inch hard drive module (which supports a maximum of two 3.5-inch SAS/SATA hard drives), Slot0-2 cannot accommodate any devices.

Riser 2 is configured the same way as Riser 1:

Riser 3 optional configuration: two 2.5-inch hard drive modules/PCIE half-height expansion module (choose 1 out of 2):

When selecting the PCIE expansion module, Slot6 can connect to PCIe X8 devices, and Slot7 can connect to PCIe X16 devices.

Note: ( In this motherboard configuration, there is one PCIe X16 slot, and the PCIe expansion module includes one X16 and one X8 slot.). When opting for the 2.5-inch hard drive module (supporting a maximum of two 2.5-inch SAS/SATA hard drives), please note that slots 6-7 cannot be used for any other devices in this motherboard configuration.

Riser 4 optional configuration: two 2.5-inch hard drive modules/PCIE half-height expansion module (choose 1 out of 2):

When selecting the PCIE expansion module, Slot8 can connect to PCIe X8 devices, and Slot9 can connect to PCIe X16 devices.

Note: (In this motherboard configuration, there are two Slimline X8 slots, and the PCIe expansion module provides one X16 slot and one X8 slot) . When choosing the 2.5-inch hard drive module

(which supports a maximum of two 2.5-inch SAS/SATA hard drives), please be aware that slots 8-9 cannot be used for any other devices in this motherboard configuration.

## 2.7.2 PCIe slot description

PCIe slot	Secondary CPU	PCIe standard	Bus bandwidth	Slot size
Onboard Network Card	CPU0	PCIe x2 (2.0)	2 *RJ45	/
OCP Network Card	CPU0	PCIe5.0 x8	1 *OCP3.0	/
Riser1	CPU0	PCIe5.0 x32	2 * PCIe5.0 X16 slot	full height full length
			1 * (PCIe5.0 X16 slot, 2 * PCIe5.0 X8 slot	full height full length
Riser2	CPU1	PCIe5.0 x32	2 * PCIe5.0 X16 slot	full height full length
			1 * PCIe5.0 X16 slot, 2 * PCIe5.0 X8 slot	full height full length
Riser3	CPU1	PCIe5.0 x16	1 * PCIe5.0 X16 slot	half height half length
	CPU1		2 * PCIe5.0 X8 slot	half height half length
Riser4	CPU1	2*Silmline X8	1 * PCIe4.0 X16 slot	half height half length
	CPU1		2 * PCIe4.0 X8 slot	half height half length
<p>Note:</p> <ul style="list-style-type: none"> <li>◆ A PCIe slot with a bandwidth of PCIe 5.0 x16 is backward compatible with PCIe x8, PCIe x4, and PCIe x1 PCIe cards. However, it is not upward compatible, meaning the PCIe slot's bandwidth cannot be less than the bandwidth of the inserted PCIe card.</li> <li>◆ A full-height, full-length PCIe slot is backward compatible with full-height, half-length, and half-height, half-length PCIe cards. A full-height, half-length PCIe slot is backward compatible with half-height, half-length PCIe cards.</li> <li>◆ All slots have the power capability to support PCIe cards with a maximum power consumption of 75W. The power consumption of the PCIe card depends on the card's model.</li> </ul>				

Table (2-12)

Note: When CPU1 is not in place, its corresponding PCIe slot is unavailable



## 2.7.3 PCIe expansion module

- PCIe adapter card 1: RM2U748-PCIEIB1-X16X8X8
  - Installed at Riser1/2 position, providing 1 PCIe5.0 X16 slot and 2 PCIe5.0 X8 slots.

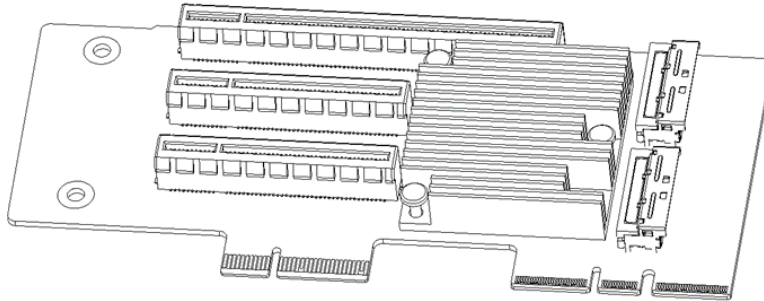

Figure(2-18)

- PCIe adapter card 2:748-PCIEIB2-X16X16
  - Installed in Riser1/2 position, providing 2 PCIe5.0 X16

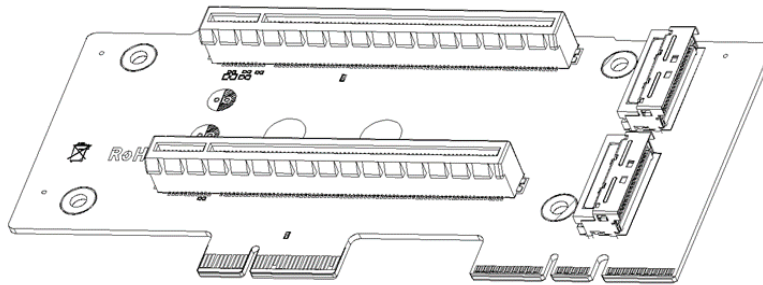

Figure (2-19)

- PCIe adapter card 3: M2U748-PCIEIB3-X16
  - Installed in Riser3 position, providing 1 PCIe5.0 X16 slot

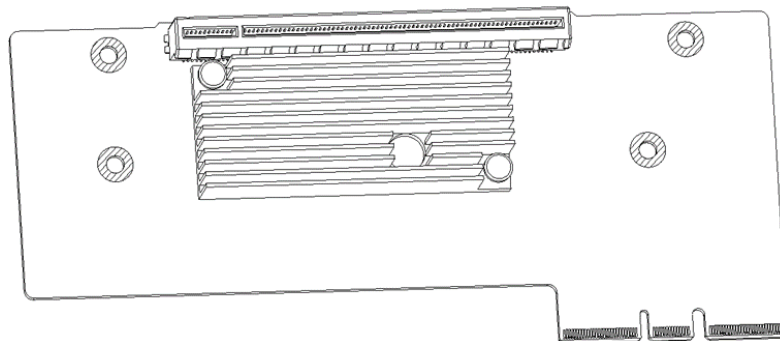

Figure (2-20)

### 3.5-inch hard drive module

- Supports in Riser1/2 positions, a single module providing 2 slots for 3.5-inch hard drives

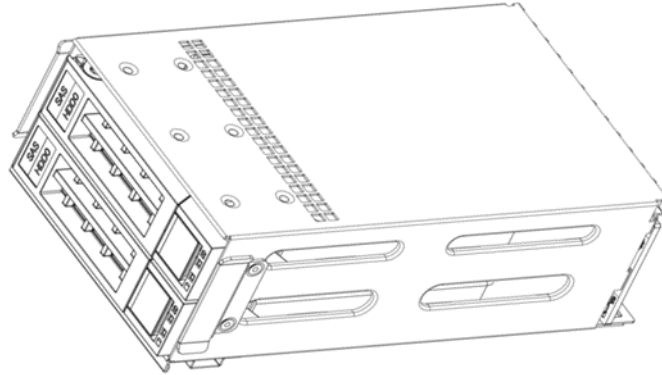

Figure (2-22)

- 2.5-inch hard drive module

- Installed in Riser3/4 positions, a single module provides 2 slots for 2.5-inch SATA or NVMe hard drives

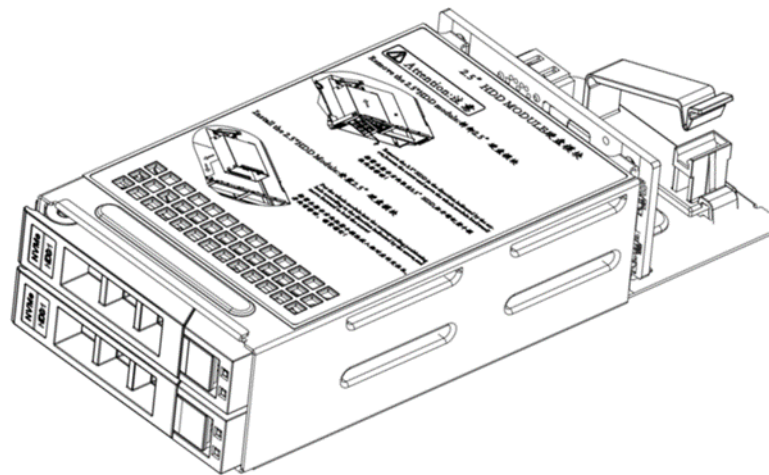
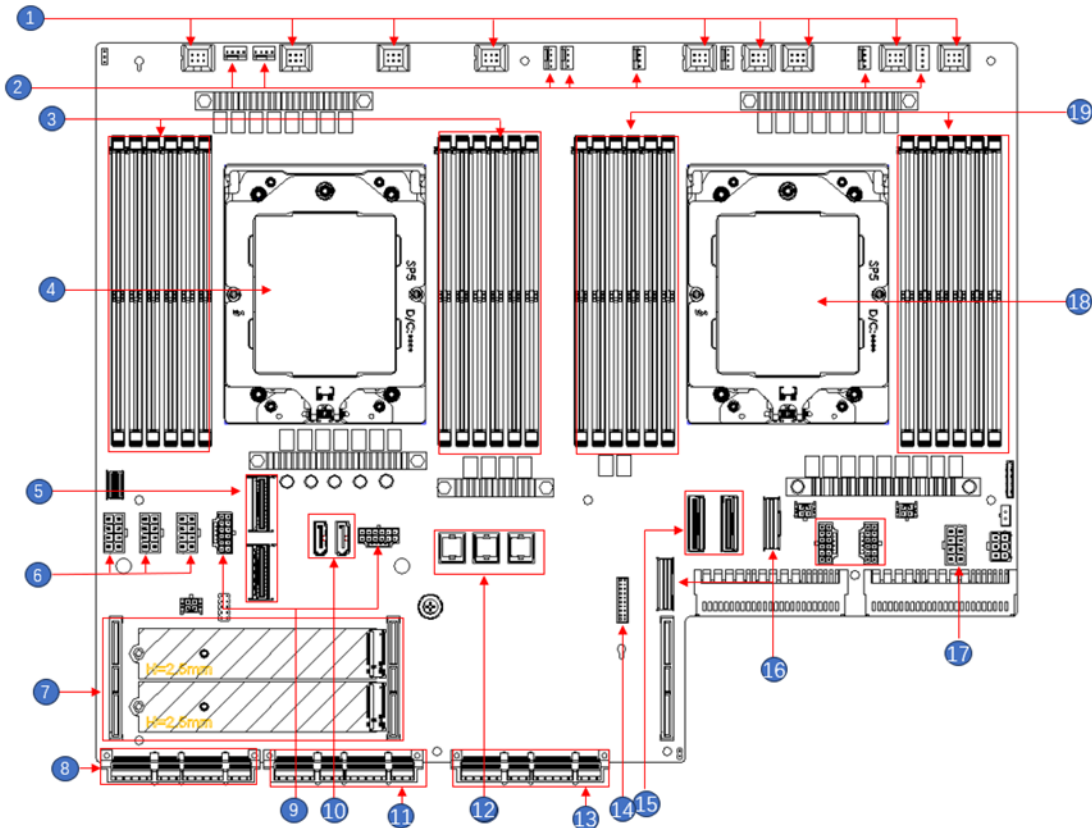

Figure (2-23)

## 2.8 PCBA

### 2.8.1 Motherboard



G2DLRO-B motherboard diagram (2-24)

No.	Name	No.	Name
1	2U chassis fan control 6pin interface	11	BMC_OCP2
2	4U chassis fan control 4pin interface	12	8643 interface
3	Memory slot (corresponding to CPU0)	13	OCP3.0
4	CPU0	14	BP HDD LED
5	Riser1 MCIO interface	15	Riser3 MCIO interface
6	BP Power 2*4 pin interface	16	Slimline PCIe4.0 X8
7	M.2	17	BP Power 2*4 pin interface
8	BMC_OCP1	18	CPU1

9	GPU Power 16 pin interface	19	Memory slot (corresponding to CPU1)
10	SATA 3.0 interface		

Table (2-13)

## 2.8.2 Hard drive backplane

- Front 8×3.5-inch hard drive backplane

Top surface

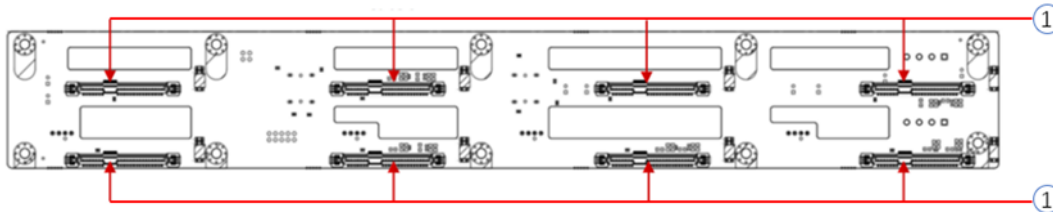

Figure (2-25)

No.	Description	Function
1, 2	SAS/SATA hard drive connector	1.Support 12Gb/s SAS hard drive; 2.Support 6Gb/s SATA hard drive; 3. Support SAS/SATA hard drive hot swap.

Table (2-14)

Bottom surface

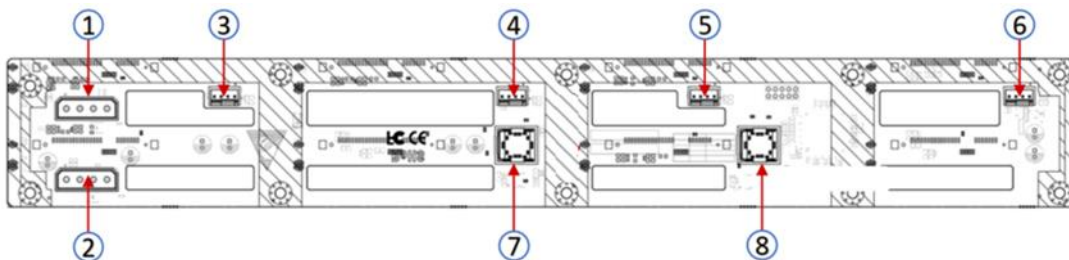

Figure (2-26)

No.	Description	Function
1, 2	ATX power input	Backplane power transmission connector for 12V power transmission
3, 4, 5, 6	Temperature controlled fan socket	For 4pin fan interface
7, 8	MiniSAS HD High Speed Connector	For transmission of 12Gb/s SAS or 6Gb/s SATA signals

Table (2-15)

## 12×3.5-inch backplane

### Top surface

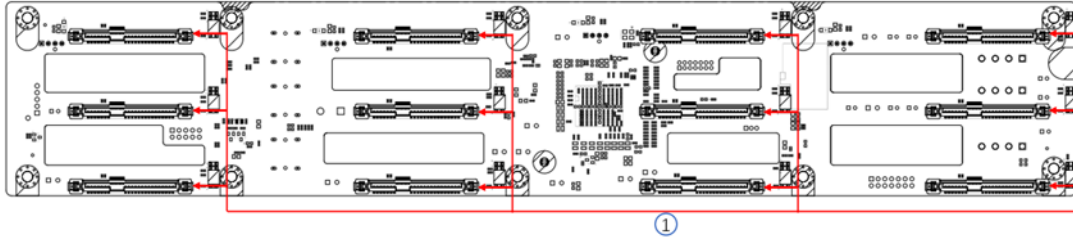

Figure (2-27)

No.	Description	Function
1	SAS/SATA hard drive connector	1.Supports 12Gb/s SAS hard drives. 2.Supports 6Gb/s SATA hard drives. 3.Supports hot-swappable SAS/SATA hard drives.

Table (2-16)

### Bottom surface

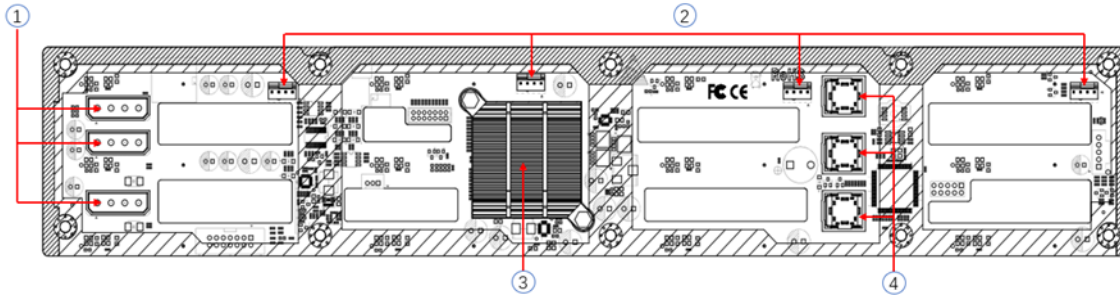

Figure (2-28)

No.	Description	Function
1	Power Connectors	Backplane power transmission connector for 12V power
2	Temperature-Controlled Fan Socket	used for 4pin fan interface
3	EXPANDER Chip	PM8043 SXP 24Sx12G 24-port 12G SAS Expander
4	MiniSAS HD High-Speed Connector	used for the transmission of 12Gb/s SAS or 6Gb/s SATA signals

Note: \*Direct-connect backplane does not have this expansion chip.

Table (2-17)

## 25×2.5-inch backplane

Top surface

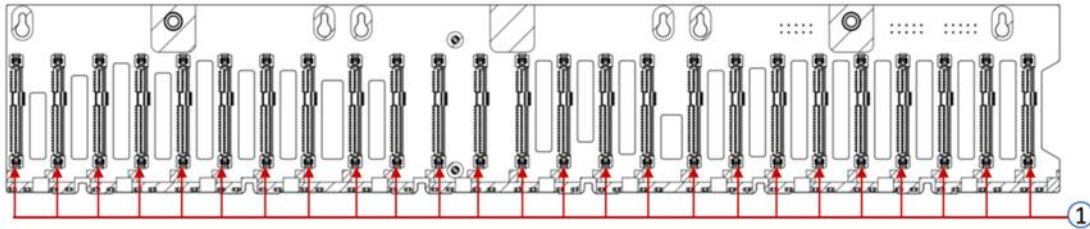

Figure (2-29)

No.	Description	Function
1	SAS/SATA hard drive connector	1. Supports 12Gb/s SAS hard drives. 2.Supports 6Gb/s SATA hard drives. 3.Supports hot-swappable SAS/SATA hard drives.

Table (2-18)

Bottom surface

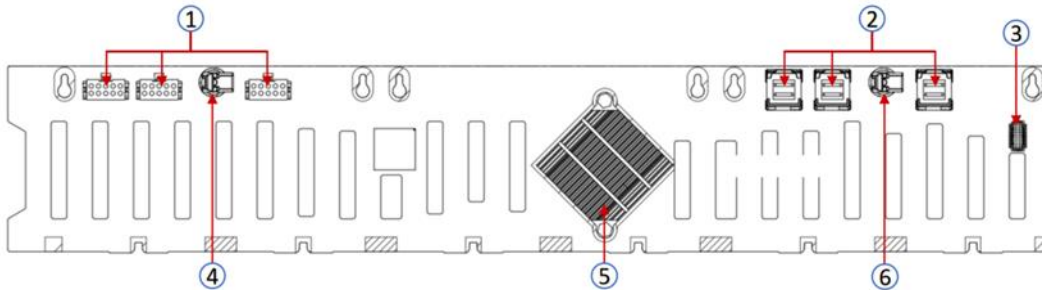

Figure (2-30)

No.	Description	Function
1	Power Connector	Backplane Power Transmission Connector for 12V Power Transfer
2	MiniSAS HD High-Speed Connector	Used for the Transmission of 12Gb/s SAS or 6Gb/s SATA Signals
3	Temperature-Controlled Fan Socket	Designed for 4-Pin Fan Connectors
4, 6	Backplane Card Latch	Secures the Backplane to the Backplane Bracket
5	EXPANDER Chip	PM8043 SXP 24Sx12G

Table (2-19)

## 2×2.5 Rear Hard Drive Backplate - 1

Top surface

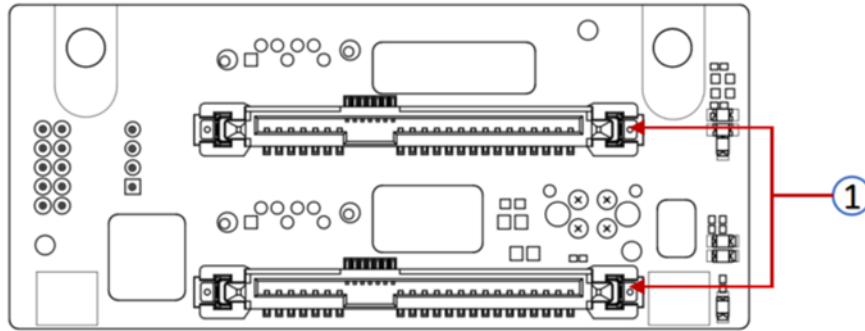

Figure (2-31)

No.	Description	Function
1	SAS/SATA hard drive connector	1.Supports 12Gb/s SAS Hard Drives 2.Supports 6Gb/s SATA Hard Drives

Table (2-20)

Bottom surface

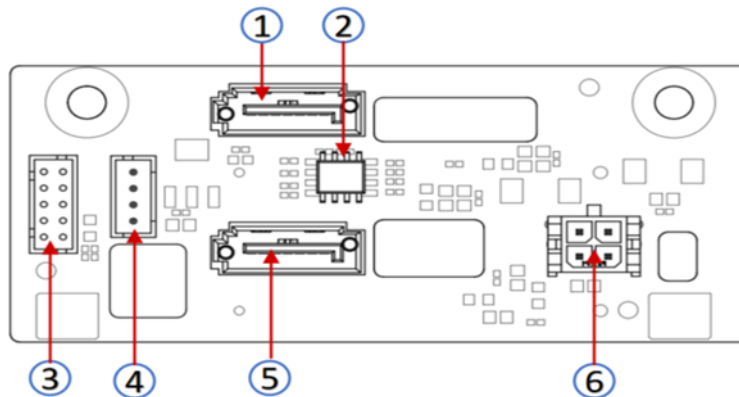

Figure (2-32)

No.	Description	Function
1、 5	7PIN SATA interface	SATA Disk Signal Cable Interface
2	Temperature Sensor IC	Temperature Sensor Chip
3	SGPIO Indicator Signal	Used for Hard Drive LED Positioning and Fault Indicator Function
4	I2C Interface	Used for I2C Signal Interface
6	Power interface	Backplane Power Transmission Connector for 12V Power Transfer

Table (2-21)

## 3. Installation Instructions

### 3.1 Chassis top cover installation

- Step 1: Align the top cover hooks with the openings on the chassis and place it downwards
- Step 2: Push it forward in the direction of the arrow until it locks into place

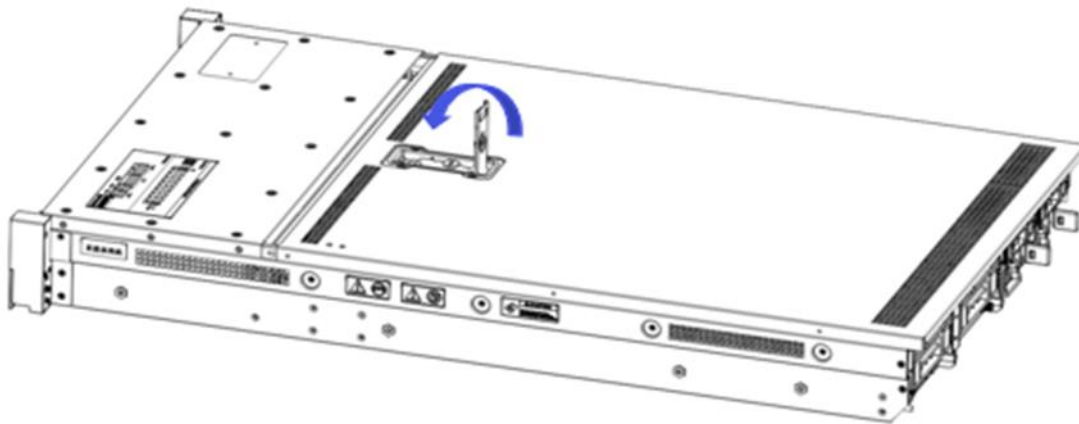

Figure (3-1)

### 3.2 Installation of accessories

#### 3.2.1 Installation of CPU

Before starting the CPU installation, please read the following guidelines:

- Make sure the motherboard supports the CPU.
- Before installing the CPU, be sure to turn off the computer and unplug the power cord from the power outlet to prevent hardware damage.
- Disconnect all cables from the power socket.
- Disconnect all communication cables from their ports.
- Place the system unit on a flat and stable surface.
- Follow the instructions to turn on the system.

 **Warning!**

Serious damage could result if the server is not properly shut down before beginning component installation. Unless you are a qualified maintenance technician, otherwise do not attempt the steps described in the following sections.

Follow the instructions below to install the CPU:

1. Loosen the three fixing screws securing the CPU cover in sequence (3→ 2→ 1).
2. Flip open the CPU cover.
3. Use the handle on the CPU tray to remove the CPU tray from the CPU rack.
4. Using the handle on the CPU bracket, insert the new CPU bracket with the installed CPU into the CPU rack.



 Note: Ensure that the CPU is installed correctly in the CPU bracket, aligning the triangle on the CPU with the top-left corner of the CPU carrier.

5. Flip the CPU rack with the CPU installed to the appropriate position in the CPU slot.
6. Flip the CPU cover to the appropriate position above the CPU slot.
7. Tighten the CPU cover screws in the order (1 → 2 → 3) to secure the CPU cover in place. Torque: 16.1 kgf-cm (14.0 lbf-in)
8. Repeat steps 1-7 for the second CPU.
9. To remove the CPU, perform steps 1-7 in reverse order.

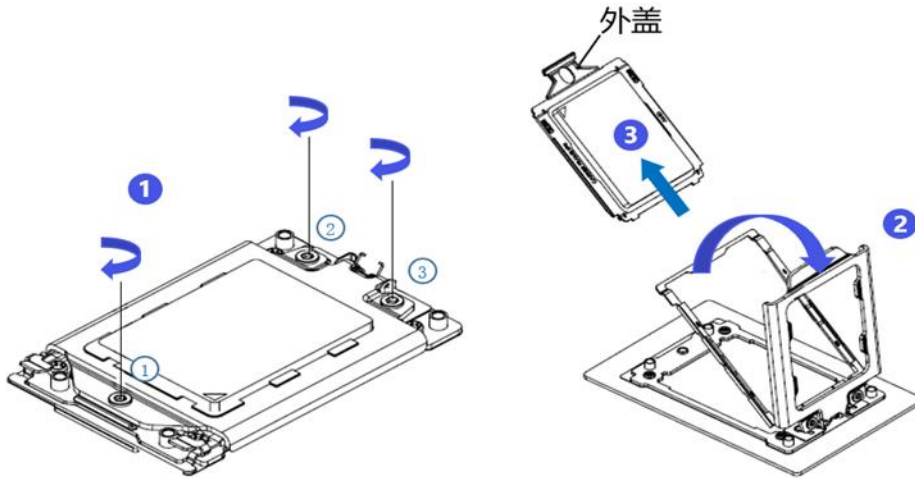

Figure (3-2)

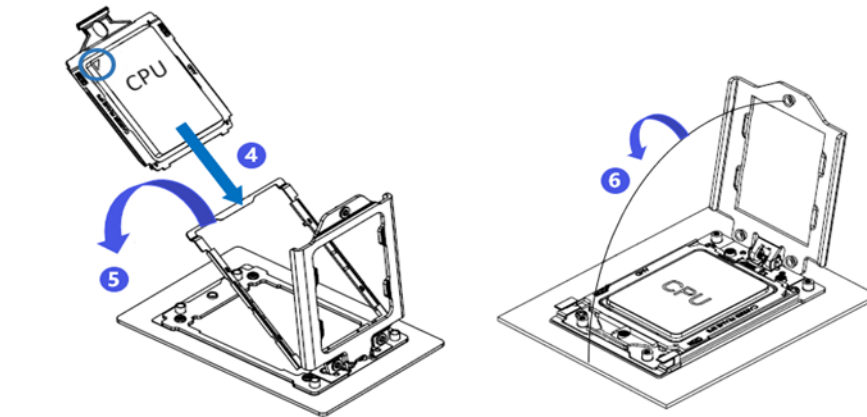

Figure (3-3)

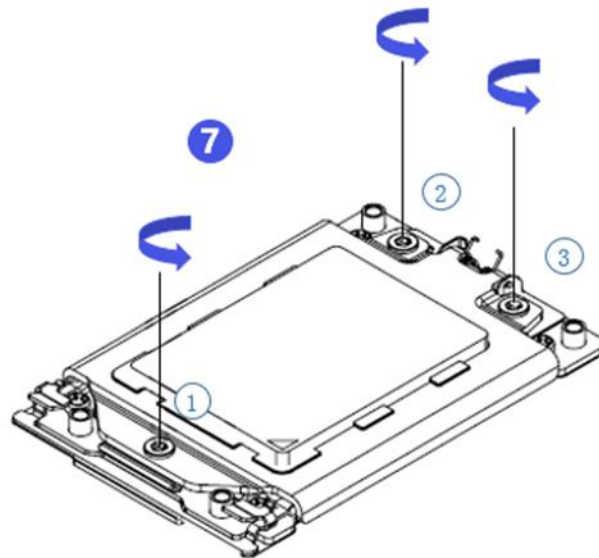

Figure (3-4)

### 3.2.2 Installation of heatsink

Before starting to install the heatsink, please read the following guidelines:

- Before installing the heatsink, please be sure to turn off the computer and unplug the power cord from the power outlet to prevent damage to the hardware.
- Unplug all cables from the power outlet.
- Disconnect all communication cables from their ports.
- Place the system unit on a flat and stable surface.
- Follow the instructions to turn on the system.

 **Warning!**

Before beginning the component installation, attempting the steps described in the following sections without shutting down the server may lead to severe damage. Only qualified technicians should carry out these procedures.

 **Note:** When installing the heatsink to the CPU, use a Phillips screwdriver to tighten the 4 retaining nuts in the order of 1-4.

Follow the instructions below to disassemble and install the heatsink:

1. Loosen the screws that secure the heatsink in place in the reverse order (4 → 3 → 2 → 1).
2. Lift the heatsink and remove it from the system.
3. To install the heatsink, reverse the process of steps 1-2, ensuring that you tighten the securing screws in the following order (1 → 2 → 3 → 4), as shown in the diagram.

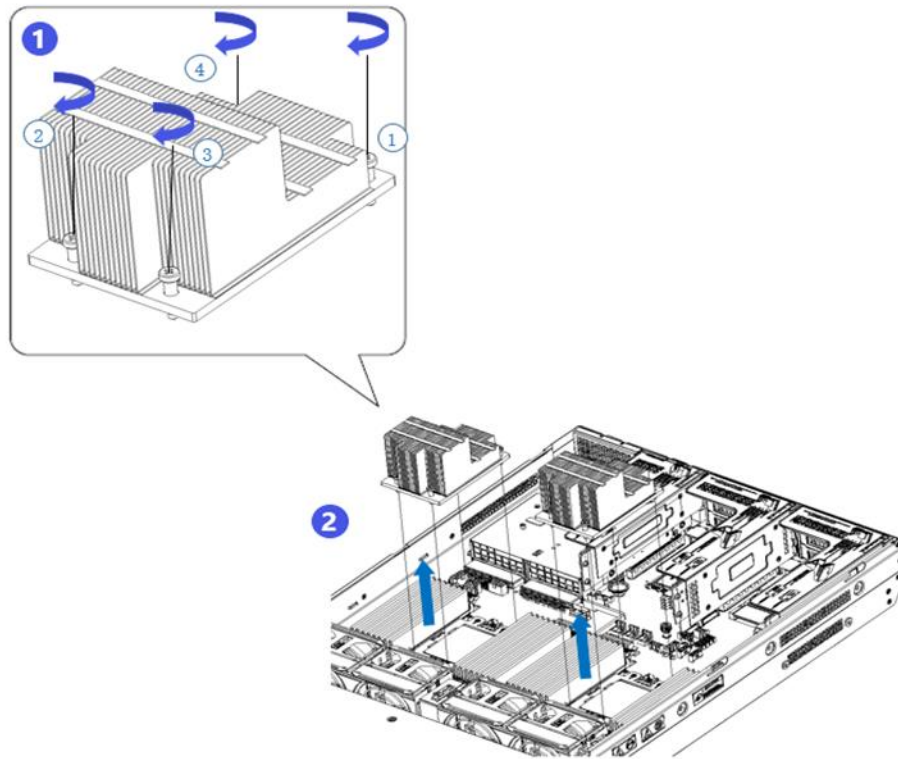

Figure (3-5)

### 3.2.3 Installation of memory

The 12 memory slots controlled by CPU 0/CPU 1 on the motherboard are as follows:

DIMM\_A,DIMM\_B,DIMM\_C,DIMM\_D,DIMM\_E, DIMM\_F,DIMM\_G,DIMM\_H,DIMM\_I, DIMM\_J, DIMM\_K, DIMM\_L.

It's important to note that the notch on the memory module should align with the notch on the DIMM slot. Insert each DIMM module vertically into place to prevent incorrect installation.

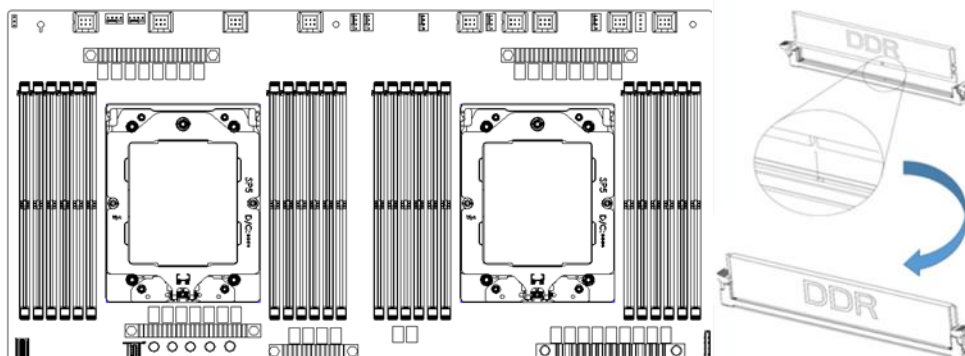

Figure (3-6)

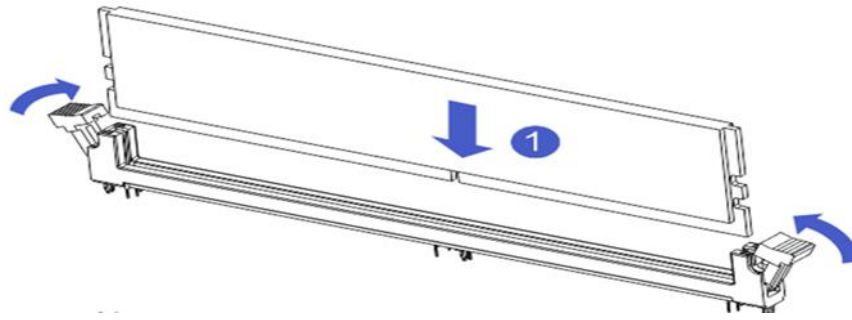

Figure (3-7)



Figure (3-8)

### 3.2.4 Installation of server slide rail

- Step 1: Prepare two slide rails and pull out the inner rail.

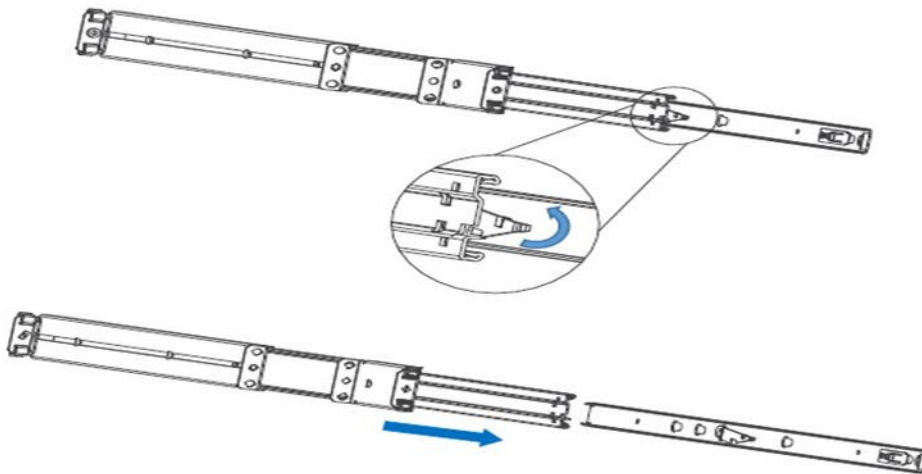

Figure (3-9)

Step 2: Fix the inner rails on both sides of the chassis.

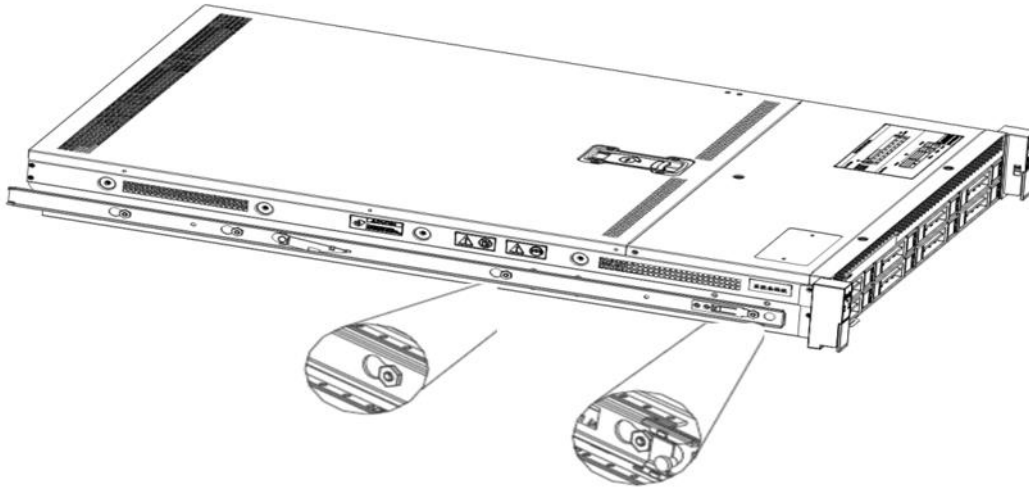

Figure (3-10)

- Step 3: Install the outer rail on the cabinet bracket and secure the screws.

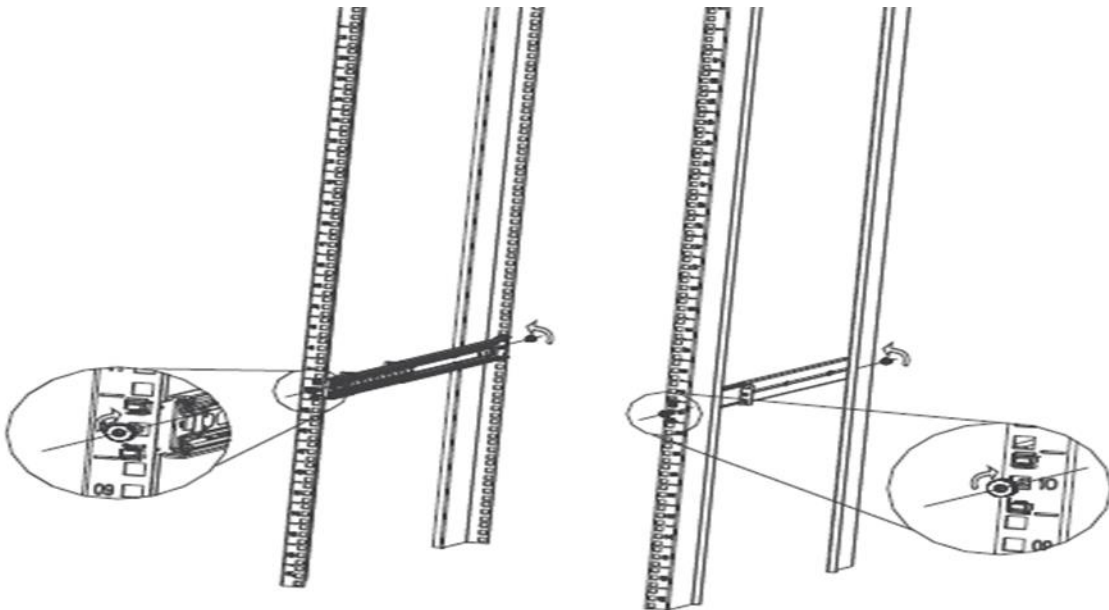

Figure (3-11)

**⚠** Note: When installing the guide rails, align them with the "U" mark. Once you hear a clicking sound, it's securely in place. Fasten it with M5 screws.

- Step 4: Align the chassis with the inner rails installed with the outer rails for installation.

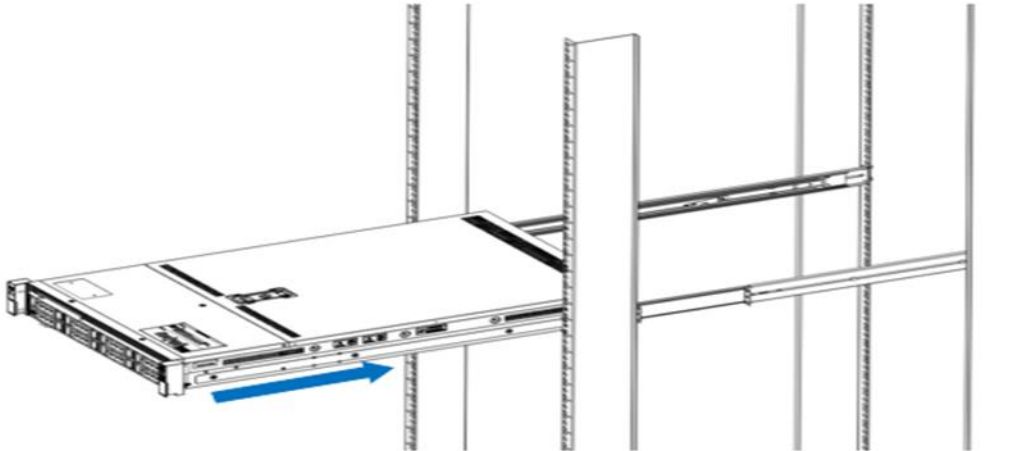

Figure (3-12)

**⚠** Note: When pushing the chassis forward, if you hear a clicking sound and cannot continue pushing, you need to downwardly press the inner rail latch to unlock it and then continue gently pushing the chassis.

- Step 5: Once the chassis cannot slide forward, make sure that the screws are securely tightened to complete the installation.

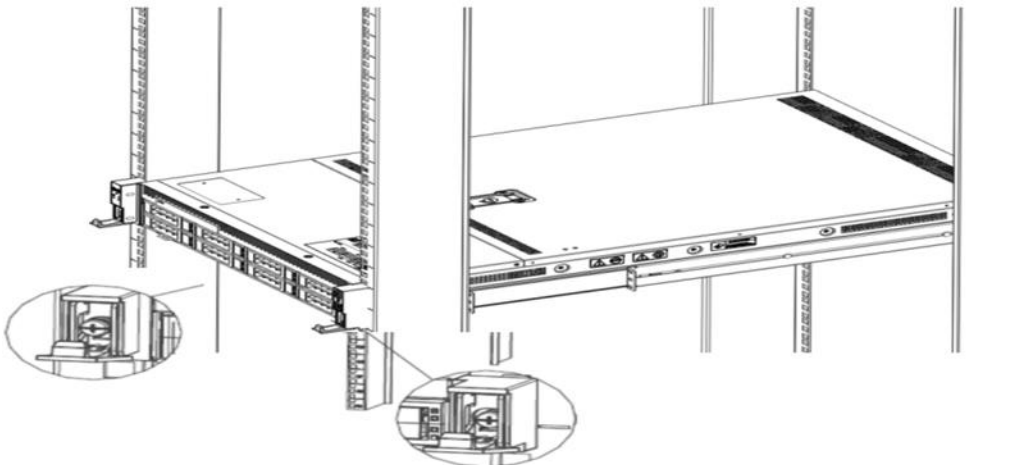

Figure (3-13)

**⚠** Note: During device maintenance, loosen the panel screws and gently pull the chassis. Avoid forcefully accelerating the sliding of the chassis to prevent damage to the equipment.

## 4. Configuration Instructions

### 4.1 Initial configuration

#### 4.1.1 Power on the system

- Before powering on, ensure that all server configurations are installed according to the corresponding specifications and standards, and the server is powered off but remains connected to the power source. Additionally, ensure that all cables are properly connected, and the power supply voltage matches the requirements of the equipment.
- During the power-on process, please do not disconnect or plug in any hard drives, power modules, network cables, or other external devices and cables.
- If the server has just been unplugged from the power supply, please wait for 1 minute before turning on the power.
- Server power-on power status:
  - When the power is connected but the server is not turned on, the power indicator light will be yellow.
  - When the power is connected and the server is turned on and booting, the power indicator light will be green.
- Server power-on method:
  - The server is set to the "power on" boot policy by default, which means that the server will automatically power on when the power is connected. Users can modify this setting in the BIOS Setup interface.
- During the boot process, press the <DEL> key on the keyboard to enter the BIOS Setup interface. Locate the following interface:

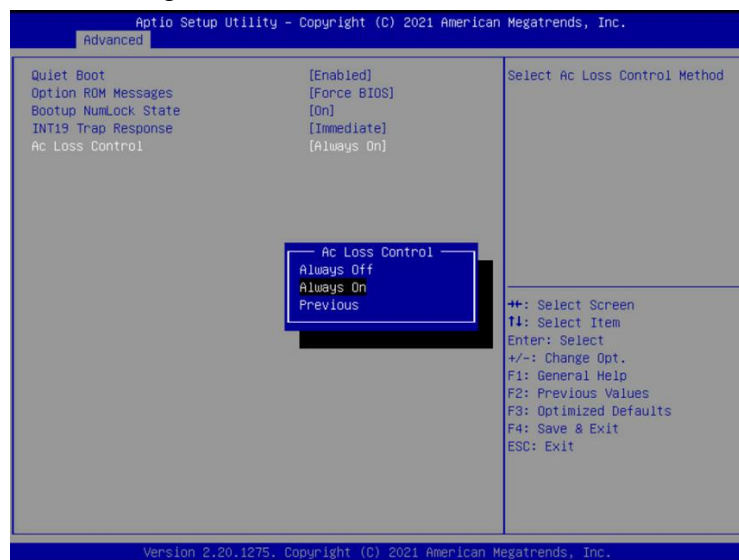

Figure (4-1)

- AC Loss Control Power-On Settings

Status settings, menu options are:

Always off: Power on directly when power is restored

Always on: Power-on requires pressing the Power button to start

Previous: Keep the power state unchanged

- You can access the iBMC management interface to remotely control power operations.
- Enter the BMC IP address -> Enter the BMC account&password -> Locate the remote control interface -> Power Controller -> Can be executed as required.



Figure (4-2)

 For detailed usage instructions for BMC and BIOS, please refer to the respective user manuals.



## 4.1.2 Initial data

- BMC default account: admin
- BMC default password: Server@123.
- BMC default address: 192.168. x. x
- BIOS default password: none

## 4.1.3 Configuration of BIOS

During the power-on process, press the <DEL> or <ESC> key on your keyboard to enter the BIOS Setup interface. The display will appear as follows:

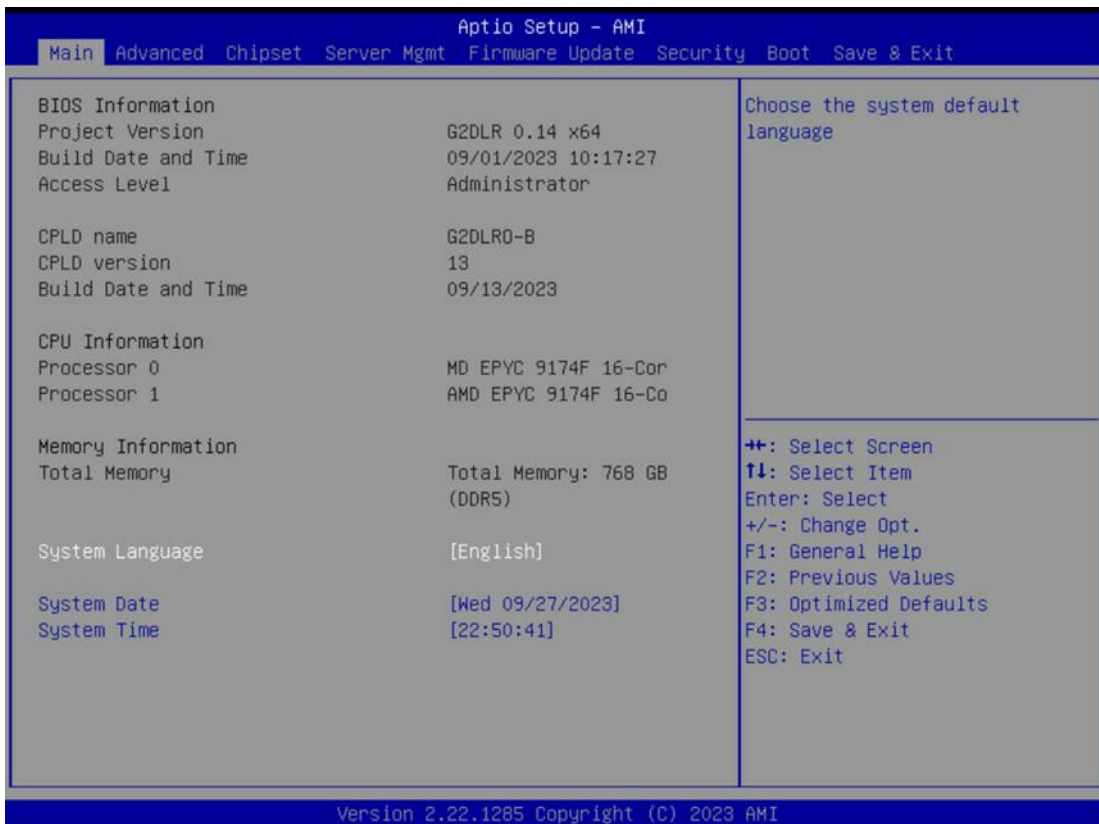

Figure (4-3)

The Main interface contains basic information about the BIOS system, such as the BIOS version number, CPU model, and memory capacity. It also allows you to set the system time. For detailed instructions, please refer to the 'BIOS User Manual'.

- Navigation key description:

- ←: Select Screen
- ↑↓: Select Item
- Enter: Select
- + /-: Change Opt.
- F 1: General Help
- F 2: Previous Values
- F 3: Optimized Defaults
- F 4: Save & Reset
- ESC: Exit

#### 4.1.4 Configuration of BMC

With the server in the powered-on state, ensure that the BMC dedicated management network cable is properly connected. Use another device within the same local network to enter the IP address into a web browser. The login interface will appear as shown below:

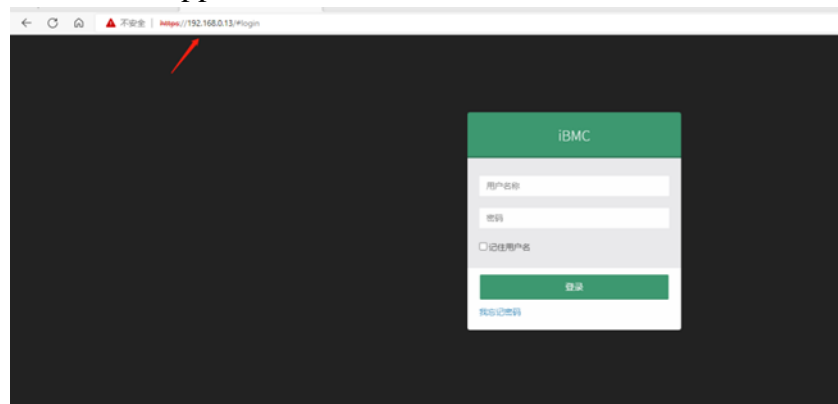

Figure (4-4)

After entering the account and password, you can access the homepage. You can set the BMC IP address in the management interface. On the left side of the interface, switch to 'Settings' -> 'Network Settings' -> 'Network IP Settings' as shown in the following image:

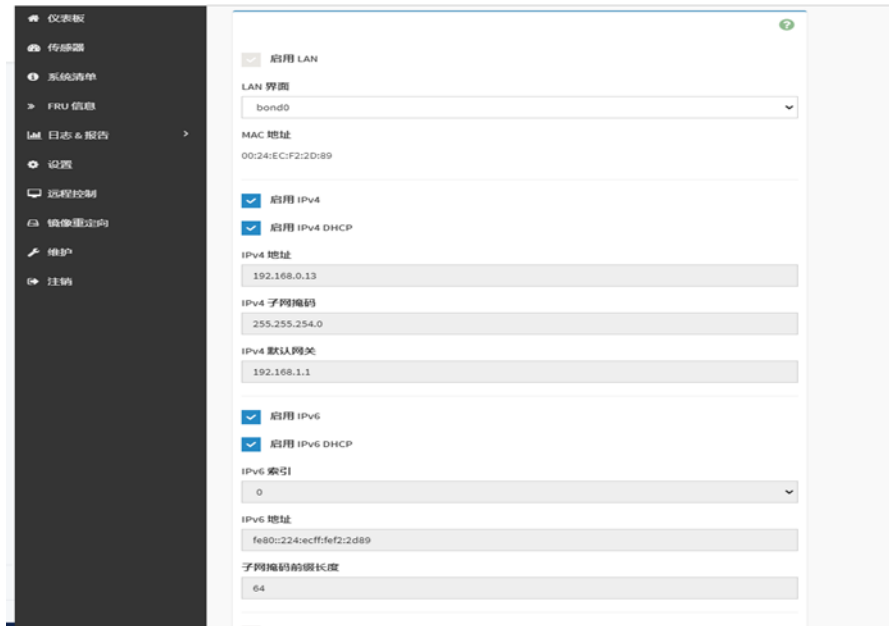

Figure (4-5)

In the powered-on state of the server, ensure that the dedicated management network cable for BMC is connected properly.

Using another device, ensure that it is on the same local network as the BMC management network. Enter the BMC IP address into a web browser to access the BMC interface.

The method to check the BMC IP address is as follows:

- After powering on the server, pay attention to the POST process during startup. On the logo screen, in the lower left corner, the IP address is displayed.
- After powering on the server, pay attention to the POST process. Press the <DEL> key or the <ESC> key on the keyboard to enter the BIOS Setup interface and switch to the following screen:

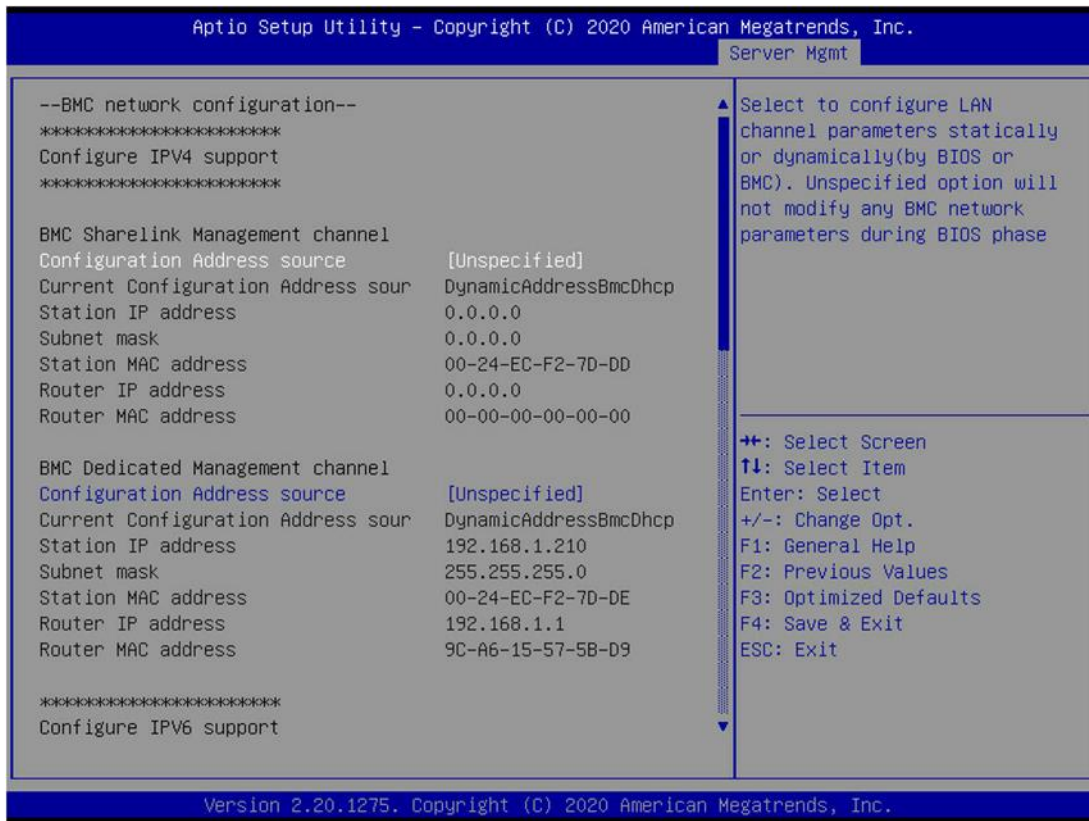

Figure (4-6)

- Configure IPV4 support
- BMC sharelink Management Channel
- Configuration Address Source: Configure BMC IP address allocation mode. The menu options are:

Unspecified: Do not change the BMC parameters(default)

Static: BIOS static IP setting

DynamicBmcDhcp: BMC is running DHCP for dynamic IP allocation.

DynamicBmcNonDhcp: BMC is running a Non-DHCP protocol for dynamic IP allocation.

- BMC Dedicated Management Channel
- Configuration Address source: Configure BMC IP address allocation mode.

The menu options are:

Unspecified: Do not change the BMC parameters(default)

Static: BIOS static IP setting

DynamicBmcDhcp: BMC is running DHCP for dynamic IP allocation.

DynamicBmcNonDhcp: BMC is running a Non-DHCP protocol for dynamic IP allocation.

- 
- Configure IPV6 support
  - Select whether to support IPv6, with the following menu options:
    - Enabled: Supports IPv6
    - Disabled: Does not support IPv6
  - After modifying from Unspecified to other parameters, saving and restarting, the option will revert to the Unspecified value. There is no need to configure the BMC IP during every startup process.
  - When the 'Configuration Address Source' option is set to 'Unspecified,' it will display network parameter information (IPv4) for the system's shared network interface. This includes the current IP configuration method, BMC IP, subnet mask, MAC address, route IP, and route MAC.

## Appendix

(Common fault diagnosis)

### **No display after power on**

- Make sure the monitor cable is properly connected and the power indicator on the monitor lights up when the monitor is powered on.
- Ensure the monitor is connected to the server.
- If the above steps do not resolve the issue, try replacing the monitor with a known working one to confirm if the original monitor is faulty.
- If the issue persists, please contact SNR technical support for further assistance.

### **Front Panel Indicator Lights Alarm**

- Refer to the instructions in the manual to determine the specific alarm information indicated by the front panel lights and buttons.
- For power failure indicator lights alarm, check if the power module indicator lights on the rear window of the server are abnormal. If the power module indicator lights are normal, please contact SNR technical support for further assistance. If the power module indicator lights are not normal, please ensure that the server, power module, and power cords are functioning correctly.
- For system alarm indicator lights, first check the external environment.
- For other indicator light alarms, please contact SNR technical support for further assistance.

### **Abnormal Hard Drive Indicator Lights**

- Ensure the hard drives are properly installed.
- Refer to the instructions in the manual to determine the specific alarm information indicated by the rear panel lights and buttons.
- Confirm if the RAID card is configured correctly.
- Check for any drive dropouts during OS installation. If this occurs, please contact SNR technical support for further assistance.

### **Unable to Use RAID Card**

- Ensure the RAID card is properly installed.

- 
- Try reseating the RAID card and PCIe adapter to confirm if they are functioning correctly.
  - If the issue persists even after replacing the RAID card with a known working one, restore to factory settings and update the BIOS version. Contact SNR technical support for further assistance.

**IPMI Connection Failure**

- Confirm if the BMC function is correctly enabled in the BIOS.
- Check if the switch and network cables are functioning properly. If the regular IPMI connection is not effective, check the network environment.
- Set static or dynamic IP and ensure ping connectivity. If the web interface does not open, try using a newer version of Internet Explorer.
- If the problem is not resolved, please contact SNR technical support for further assistance.