

SNR-JB316D User Manual

Table of Contents

PREFACE.....	4
SAFETY INFORMATION.....	4
CAUTION	5
SPECIFICATIONS.....	6
1 Product Introduction.....	7
1.1 Box Contents	7
1.2 General Information	8
1.2.1 Front Panel Controls and Indicators	9
1.2.2 Rear Panel Configuration	10
1.2.2.1 Expander Configuration	10
2 Hardware Installation	11
2.1 Removing and Installing a Hard Drive.....	11
2.1.1 Installing a Hard Drive	11
2.1.2 Removing a Hard Drive.....	12
2.2 Removing and Installing the Fan Module	12
2.2.1 Removing the Fan Module	12
2.2.2 Installing the Fan Module.....	13
2.3 Removing and Installing the PSU Module.....	13
2.3.1 Removing the PSU Module.....	13
2.3.2 Installing the PSU Module	14
2.4 Removing and Installing the Expander Module.....	15
2.4.1 Removing the Expander Module.....	15
2.4.2 Installing the Expander Module	16
2.5 Rail Installation	16
2.5.1 The Type of Rail Kit.....	16
2.5.2 Fixed Rails.....	16
2.5.3 Slide Rail	17
2.5.3.1 Take out the Inner Rail and Slide the Intermediate Rail Back	17
2.5.3.2 Attach the Inner Rail to the Chassis.....	17
2.5.3.3 Mount the Rail Bracket to the Cabinet.....	18
2.5.4 Insert the Chassis to the Cabinet.....	19
3 Expander Board Introduction	20
4 Ethernet Management Card Introduction	21
5 User Interface Introduction.....	22
5.1 Overview	22
5.2 Key Features	22
5.3 Software Management.....	23
5.3.1 System Management Structure.....	23
5.3.1.1 With Ethernet Management	23
5.3.1.2 Without Ethernet Management.....	24
5.3.1.3 Network Protocols Support	25

5.3.1.4 Operation Modes	25
5.3.2 Serial Port Management	28
5.3.2.1 CLI.....	28
5.3.2.1.1 Scenario 1: Expander with Ethernet board	28
5.3.2.1.2 Scenario 2: Expander w/o Ethernet board	31
5.3.3 Network Management	32
5.3.3.1 Telnet	33
5.3.3.2 SSH.....	33
5.3.3.3 Web UI.....	35
5.3.3.4 SNMP	36
5.3.4.2 CLI (UART, Telnet and SSH with Ethernet Board)	38
5.3.4.3 Web-GUI.....	38
5.3.5 System Status.....	40
5.3.5.1 CLI (UART without Ethernet Board)	40
5.3.5.2 CLI (UART, Telnet and SSH with Ethernet Board)	40
5.3.5.3 Web-GUI.....	41
5.3.6 Network Settings	42
5.3.6.1 CLI (UART, Telnet and SSH with Ethernet Board)	42
5.3.6.2 Web-GUI.....	42
5.3.7 Disk Information	43
5.3.7.1 CLI (UART without Ethernet Board)	43
5.3.7.2 CLI (UART, Telnet and SSH with Ethernet Board)	43
5.3.7.3 Web-GUI.....	44
5.3.8 Zone Setting.....	46
5.3.8.1 CLI (UART without Ethernet Board)	46
5.3.8.2 CLI(UART, Telnet and SSH with Ethernet Board)	46
5.3.8.3 Web-GUI.....	48
5.3.9 Firmware Upgrade	49
5.3.9.1 CLI (UART without Ethernet Board)	49
5.3.9.1.2 SAS Expander MFG CFG binary	51
5.3.9.2 CLI (Telnet or SSH with Ethernet board).....	52
5.3.9.3 Web-GUI (with Ethernet board)	54
5.3.10 System Logs	57
5.3.10.1 CLI (UART without Ethernet Board)	57
5.3.10.2 CLI (UART, Telnet, SSH with Ethernet Board)	59
5.3.10.3 Web-GUI (With Ethernet Board).....	60
6 Compatibility Lists	61
7 Q&A	61
8 Technical Support	63



PREFACE

Thank you for choosing SNR-JB316D. This manual is written for system technicians who are responsible for installation, troubleshooting, managing and repairing this server chassis. This document provides the overview of all the features of the chassis, a list of accessories or other components you may need to finish the installation, troubleshooting methods and instructions on adding and removing components on the SNR-JB316D. For the latest version of this manual, you may visit server website to download the latest updated version.

SAFETY INFORMATION

To ensure a safe and smooth operation of your SNR-JB212D, it is essential that you choose an appropriate location for the system, provide an appropriate operating environment and supply an adequate amount power for all components of the system. As you plan for installation, follow the guidelines below to ensure that the system and its environment are safely and appropriately positioned for efficient operation and service. Your system should be installed and serviced only by a qualified technician.

Environment selection: The system is designed to operate in a typical office environment:

- The location should be clean, dry and free of airborne particles.
- It should be a well-ventilated room, and away from sources of heat including direct sunlight and radiators.
- It should be kept away from sources of vibration or physical shock.
- The space should be accommodated with a properly grounded wall outlet, and with sufficient space to access the power supply cords.
- The operating environment temperature should be around 0°C to 40°C (32°F to 104°F).

Heed safety instructions: Before working with IPC/Storage server products, we strongly recommend you use this guide as a reference and follow the safety instructions. The instructions in this manual will help you ensure and maintain compliance with existing product certifications and approvals. Follow the described, regulated components mentioned in this manual. Use of non-UL listing products or other regulators may not comply with product regulations in the region(s) in which the product is sold.

System power on/off: The power button DOES NOT totally turn off the system AC power. To remove the power of the system, you must unplug the AC power cord from the outlet or the system's power supply units. Make sure the power cord is unplugged before you open the chassis, add or remove any components.

Hazardous conditions, devices and cables: Hazardous electrical conditions can be present on/in power supply units and their cables. Disconnect the power cord and any other device attached to the server before opening the case. Failing to follow safety procedures will increase the risk of personal injury or equipment damage.

Electrostatic discharge (ESD) and ESD protection: In most cases, ESD may damage disk drives,

electronic boards and other parts. We recommend that you conduct installation only at an ESD free space. If not possible, perform ESD protection protocol by wearing an anti-static wrist straps attached to the ground on any unpainted metal surface on your server during operation.

Installing or removing jumpers: A jumper is a short length conductor used to close, open or bypass part of an electronic circuit. Jumpers on backplanes have a small tab on top that you can pick up with your fingertips. Grip the jumper carefully, and plug the jumper to cover the jumper pins on the backplane. Once you need to remove the jumper, grip the jumper and carefully pull without squeezing.

CAUTION

1. To avoid damage and maintain your safety, please read the following terms listed below:
2. No to populate hard drives and turn on the power before the system is settles down. Make sure hard drives and other components are properly connected before turning on the system.
3. Tighten or loosen all the screws with a screwdriver.
4. Apply the correct screws packed in the accessory box.
5. For your safety, please have at least two people lift and place the unit.
6. Before mounting the unit to the cabinet, make sure the rail is installed correctly.
7. When installing and removing any module or part, please use the handles.

Restricted Access Location

This server is intended for installation only in restricted access locations as defined where both these conditions apply:

- Access can only be gained by service persons or by users who have been Instructed about the reasons for the restrictions applied to the location and about any precautions that shall be taken.
- Access is through the use of a tool or lock and key, or other means of security, and is controlled by the authority responsible for the location.



SPECIFICATIONS

Industry Standard	EIA-RS310D
Storage	External: Hot-swap 3.5" x 16 (SAS 12Gbps)
Maximum Capacity	Up to 128 TB (Cascades to 3 enclosures with 48 HDDs, including 1 host server)
Power Supply	Supports <ul style="list-style-type: none"> Form Factor: 80 Plus Platinum CRPS redundant Watt: 550W
12G Expander Module	1 or 2
Cooling Fan	80 x 38mm PWM x 4
Host/Expansion Port	3 x Mini SAS HD (SFF-8644) for each 12G expander module
Management	Smart fan, thermal monitor, HDD monitor, voltage monitor, alarm warning
SES	Supports SES-2 (SCSI Enclosure Service)
Maintenance	Supports management by Ethernet and RS-232
HDD Power Management	HDD sequential power on
Temperature	0°C to 35°C
Material	Material: SGCC Thickness: 1.0 mm
Rail Kit	Fixed rail included. 20" tool-less & ball-bearing slide rail (optional)
Product Dimensions (D x W x H, Chassis Only)	520.7 x 482.6 x 131 mm (20.5" x 19" x 5.25")
Package Dimensions (D x W x H)	760 x 610 x 286 mm
Weight	<ul style="list-style-type: none"> Net weight: 18.4kg Gross weight: 21.9kg
Cubic Feet	4.68
Container Information	Single packing with pallets: <ul style="list-style-type: none"> 20': 132pcs 40': 276pcs 40' HQ: 322pcs

* The actual product is subject to change without prior notice. Development Inc. reserves the right to make any final modifications.



1 Product Introduction

1.1 Box Contents

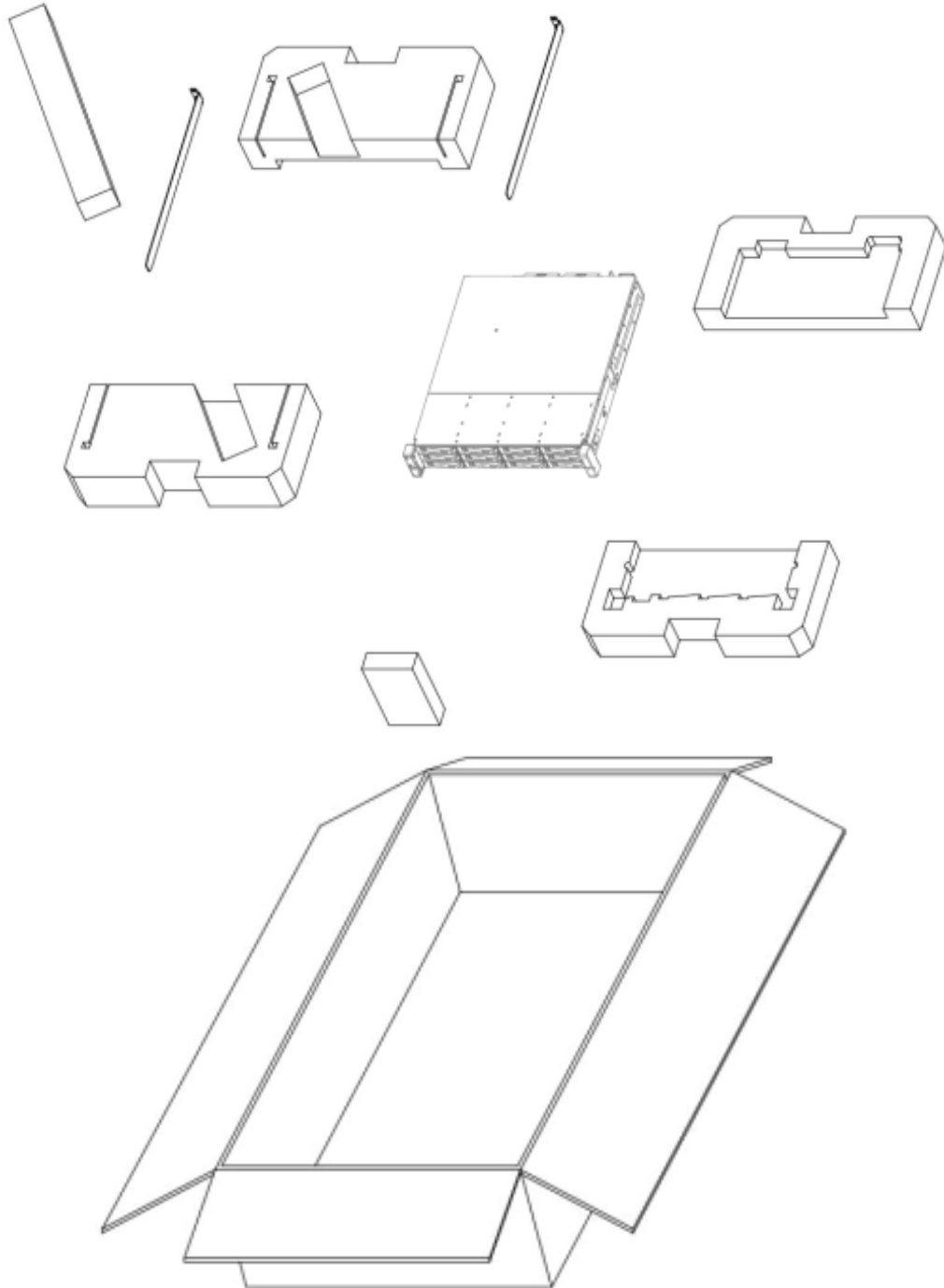



1.2 General Information

SNR-JB316D JBOD enclosure is a 3U rackmount storage chassis with 16 tool-less bays, dual expander module, dual fan module, and redundant 550W power supply. SNR-JB316D is capable of providing ample storage, while allowing users to cascade 3 enclosures with 48 HDDs, including 1 host server.

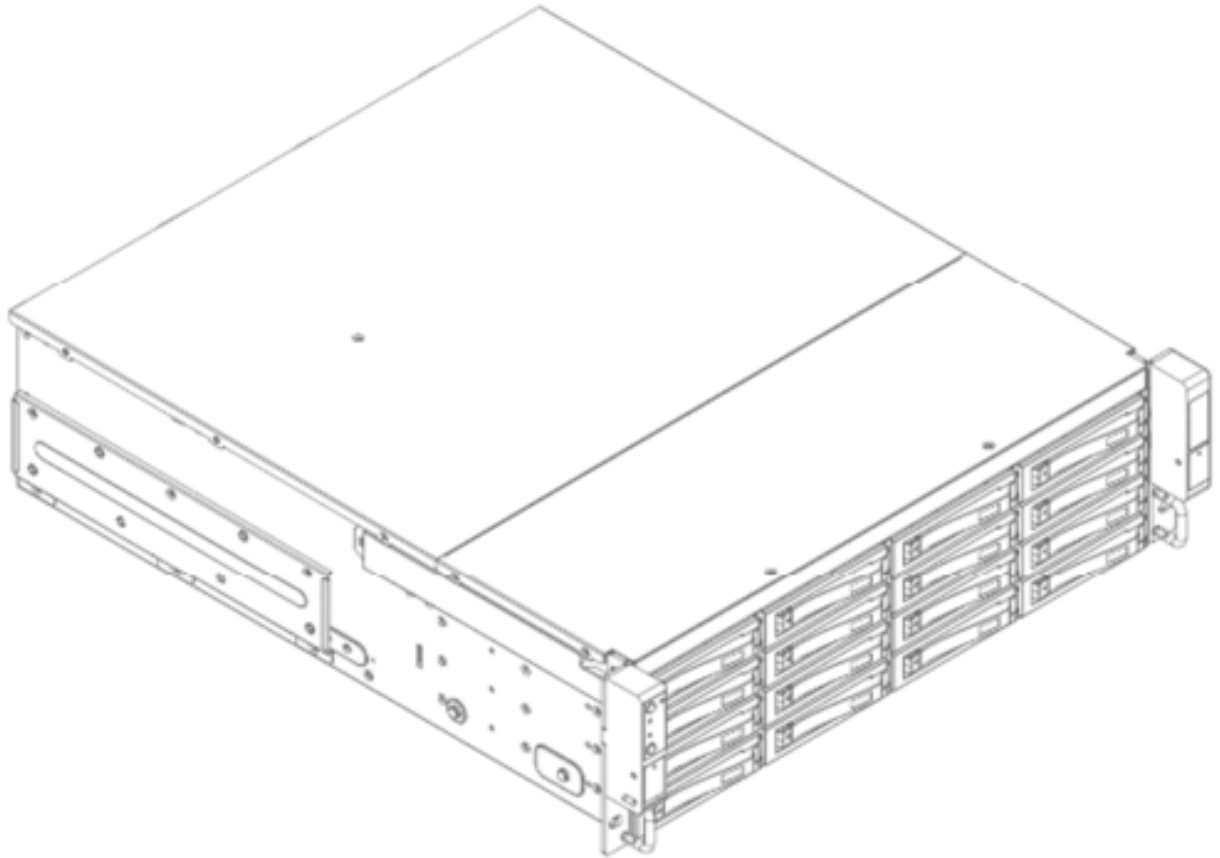



1.2.1 Front Panel Controls and Indicators

The front panel control buttons and LED indicators are located on the top left handle.

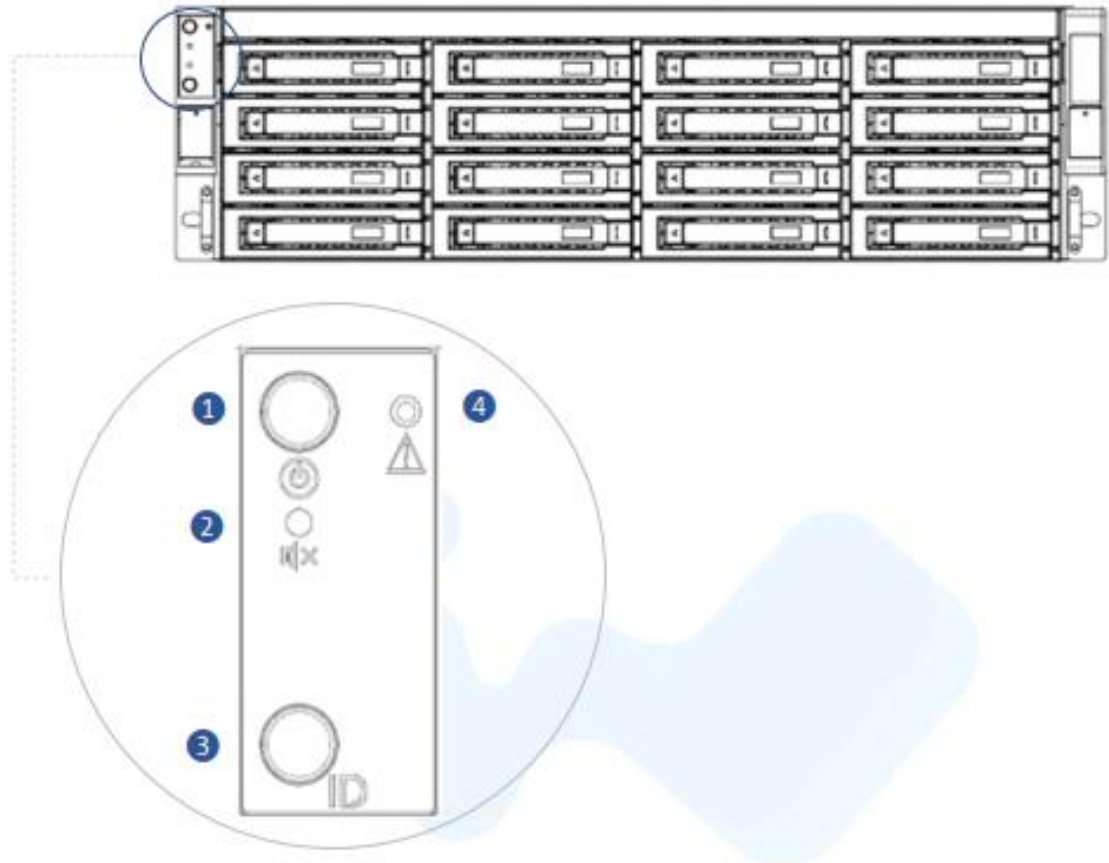

No.	Name	Color	Status	Description
1	Power On/Off Button with LED	Blue	Solid on	System is powered on
		N/A	Off	System is not powered on
2	Mute Button	N/A		Press the button to turn off the beeper
3	Chassis ID Button with LED	Blue	Solid on	Press the button to activate system identification
4	System Fail LED	Red	Solid on	System Fault (Beeper) *

* System Fault red LED indicator on the front panel illuminates and Buzzer sounds while there is system fault. Buzzer sounds differently according to the system fault. Please see the below the definition:

- High Temperature : 1 short beep
- PSU failure : 2 short beep
- Fan failure : 3 short beep

The beeps can be muted by pressing the mute button on the front panel.



1.2.2 Rear Panel Configuration

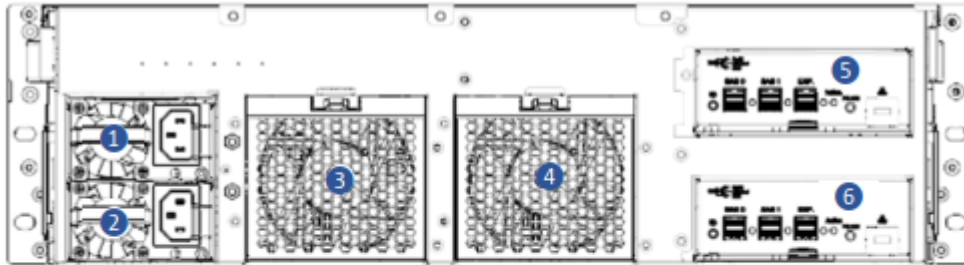

No.	Item
1	Power Module 1
2	Power Module 2
3	Fan Module 1

No.	Item
4	Fan Module 2
5	Secondary Expander Module
6	Primary Expander Module

1.2.2.1 Expander Configuration



No.	Name	Color	Status	Description
1	Chassis ID button with LED	Blue	Solid on	Press the button to activate system identification
2	Uplink SAS Port	N/A		Host HBA/RAID card connection
3	Downlink Expander Port	N/A		External cascading
4	Expander Module Status LED	Blue	Blink	Normal
		Blue	No Blinking	Abnormal
5	RS-232 Port	N/A		Debug console connection
6	LAN	N/A		Ethernet remote monitoring



2 Hardware Installation

2.1 Removing and Installing a Hard Drive

SNR-JB series JBOD features tool-less trays. Users no longer need to use screws to mount disks, and can swap drives faster.

2.1.1 Installing a Hard Drive

Step 1: Press the release button then pull outward on the handle.

Step 2: Place the 3.5" HDD into the tray.

Align the HDD screw with the two pins on the side of the tray.

Press the other side of HDD downward to the tray.

Step 3: Insert the HDD tray to the slot.

Step 4: Push back the lever until it clicks.

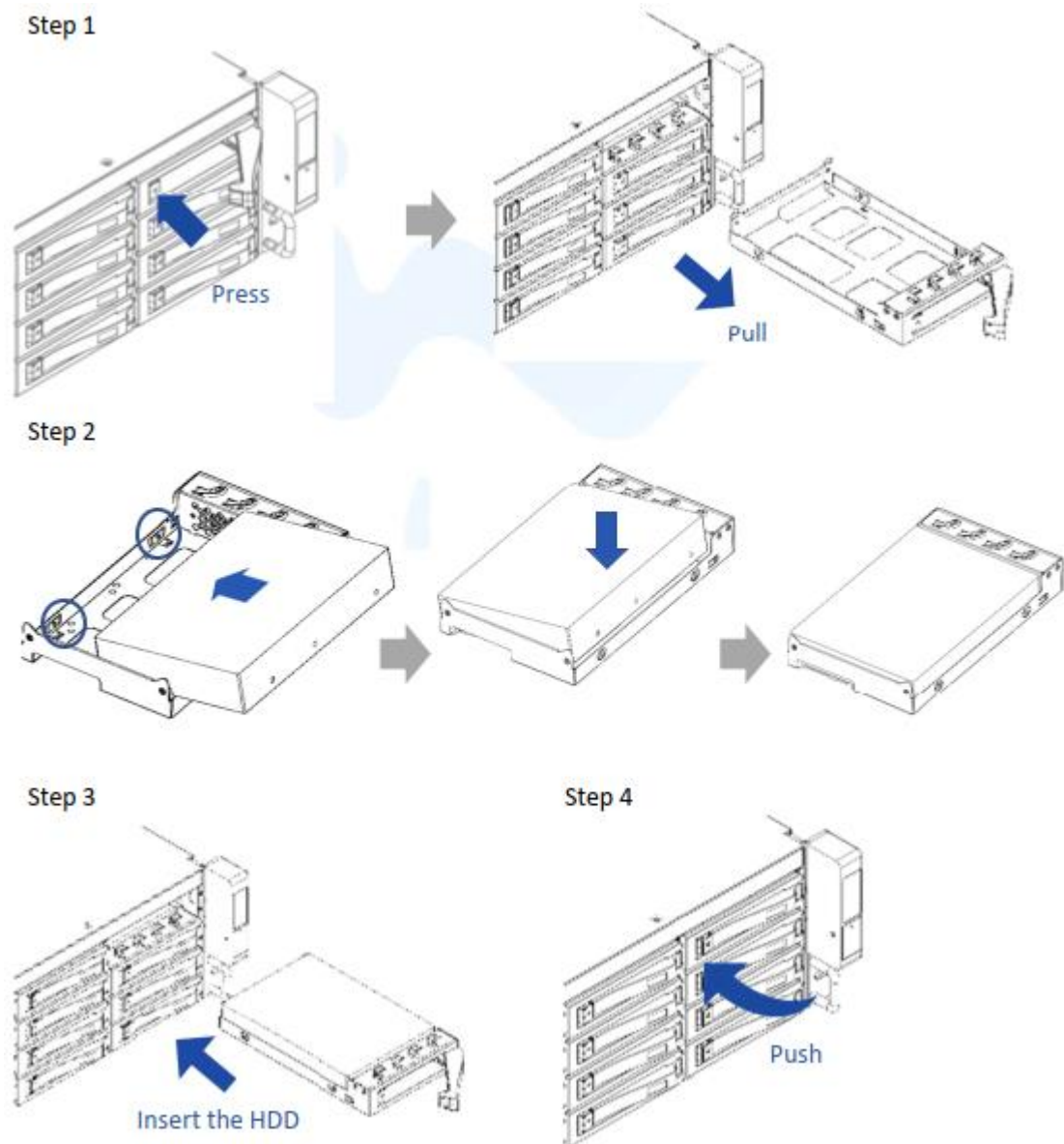



2.1.2 Removing a Hard Drive

Step 1: Press the release button then pull outward on the handle.

Step 2: Press the HDD out of the bottom of the tray with your fingers.

Step 3: Pull out the hard drive.

Step 1

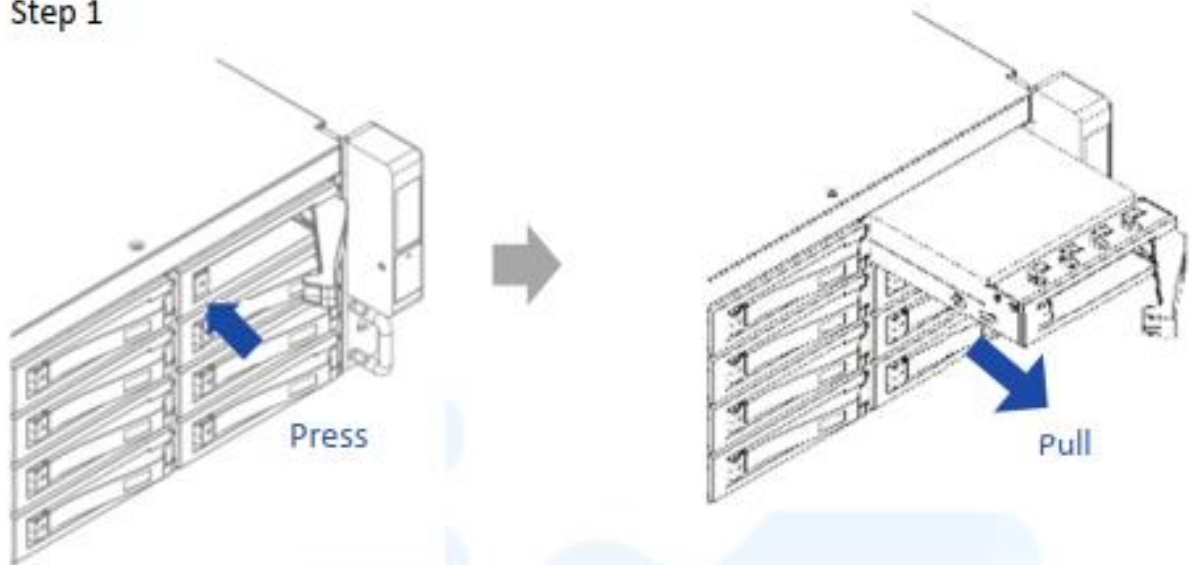

Step 2

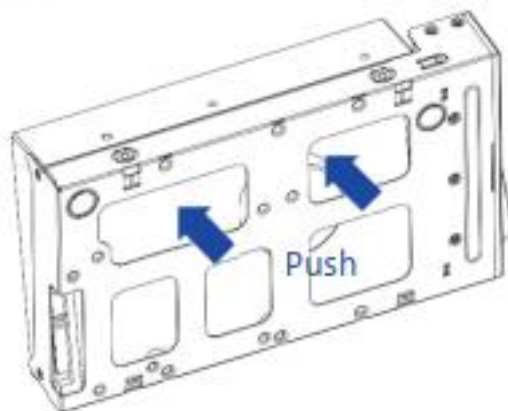

Step 3

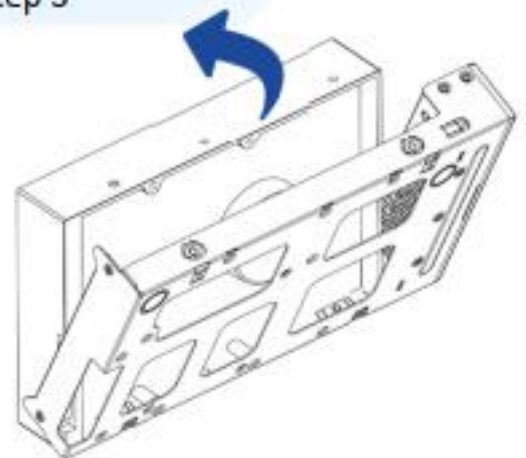

2.2 Removing and Installing the Fan Module

SNR-JB series JBOD has built-in dual fan modules that support hot-swappable and redundant features. With a tool-less design, SNR-JB series JBOD is easy to maintain.

2.2.1 Removing the Fan Module

Step 1: Press the clip to release the fan slot.

Step 2: Pull out the fan module from the fan slot.

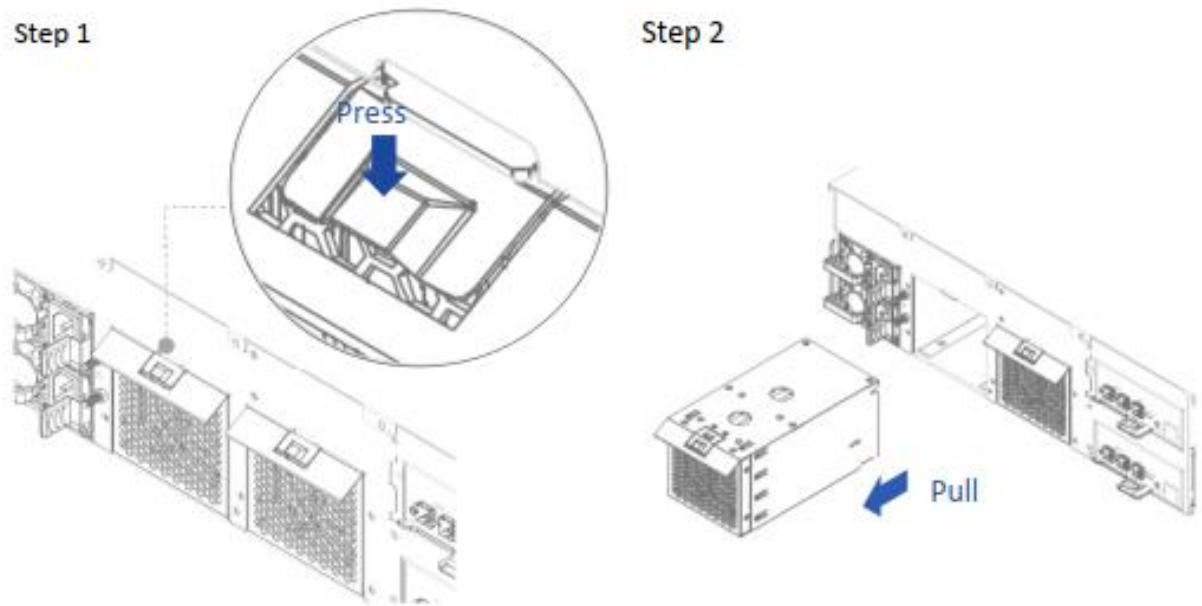

2.2.2 Installing the Fan Module

Step 1: Push the fan module back into the slot until it clicks.

Step 2: Connect the fan to the backplane.

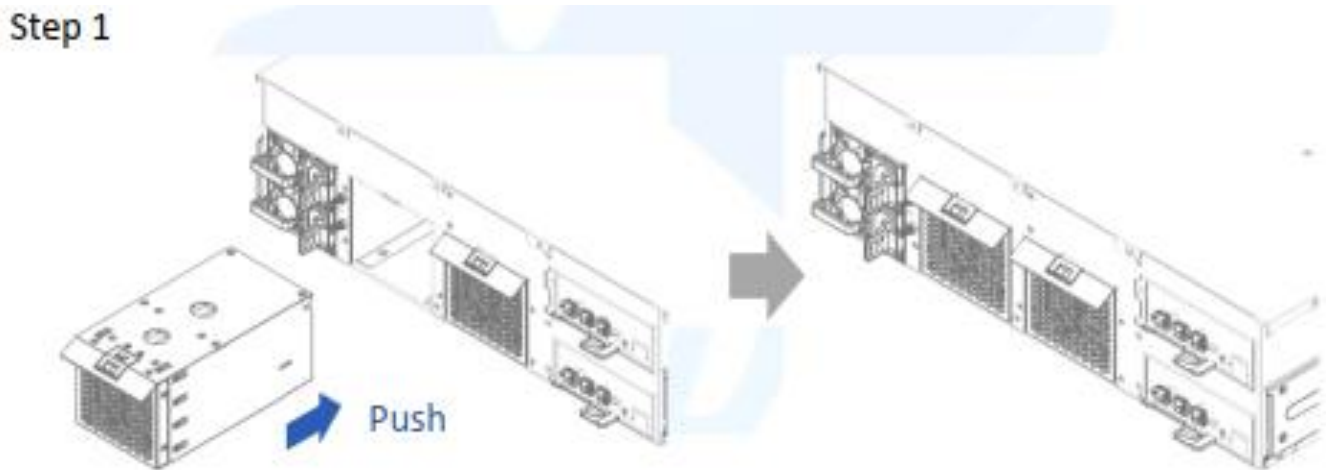

2.3 Removing and Installing the PSU Module

The SNR-JB316D hosts a built-in redundant power supply module. With this function, the system is capable of still functioning if one of the modules fail. To replace it, the user only needs to release the failed module, then insert a functional module.

2.3.1 Removing the PSU Module

Step 1: Press the release tab of the power supply unit's module at the back.

Step 2: Pull the module out using the handle.

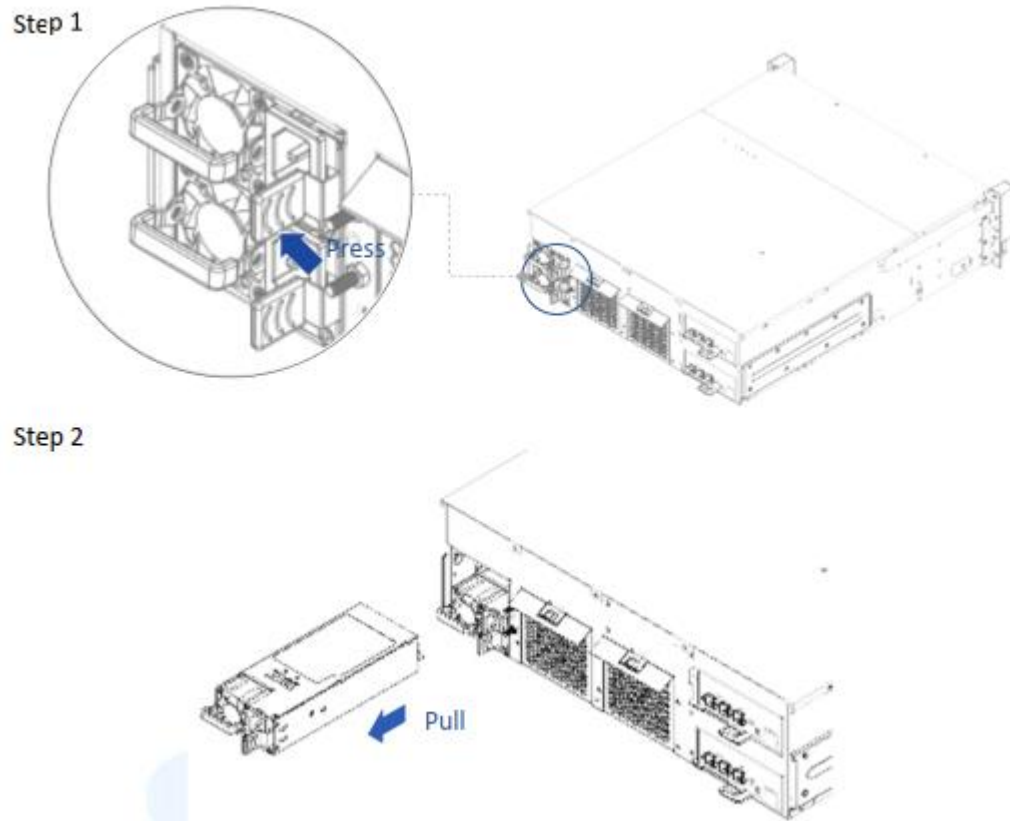

2.3.2 Installing the PSU Module

Step 1: Make sure the label is facing upward, and push the power supply module into the cage until it clicks.

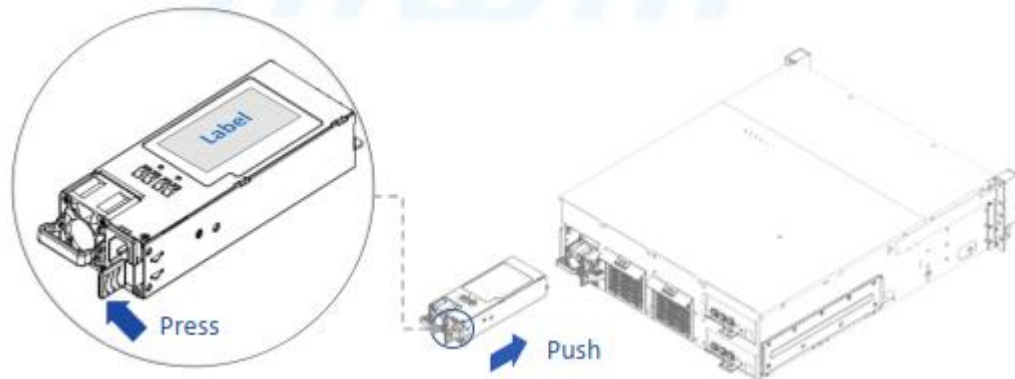

- NOTE:**
1. The unit supports PSU modules only, please do not attempt to insert any other brands of modules.
 2. The two PSU modules' output wattage must be the same.



2.4 Removing and Installing the Expander Module

SNR-JB series JBOD contains a set of redundant expander modules. The bottom module is the primary expander, while the upper is the secondary. The primary expander module includes an Ethernet management module, which allow users to monitor and manage the system through Ethernet. Also, the redundant module can minimize downtime should any on the expanders fail.

2.4.1 Removing the Expander Module

Step 1: Press the clip of the expander module and swivel the handle outward.

Step 2: Pull out the expander module.

Step 1

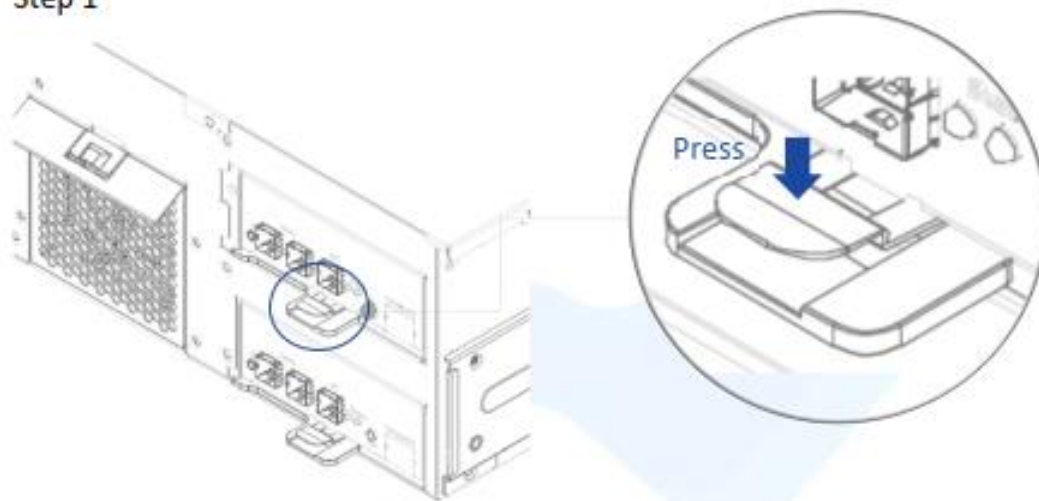

Step 2

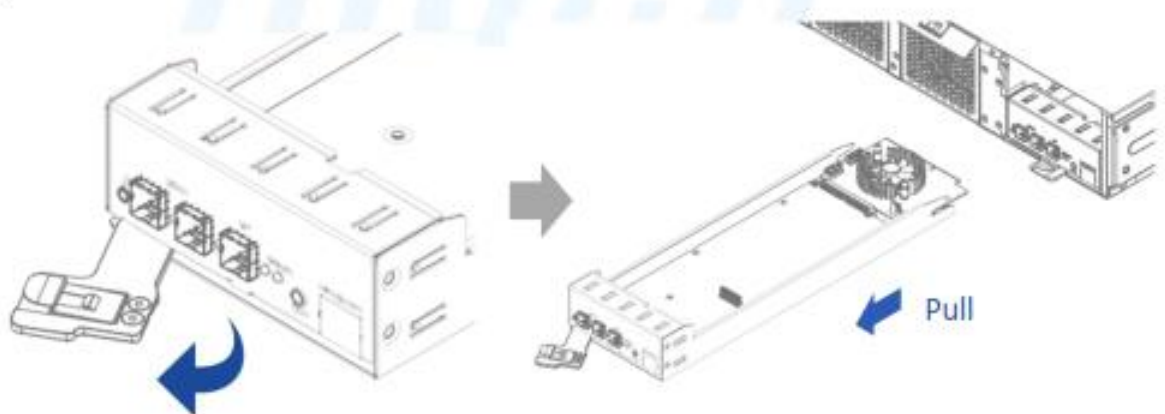



2.4.2 Installing the Expander Module

Step 1: Push the expander module into the cage until it clicks back the original location.

Step 2: Swivel the handle back to lock into position.

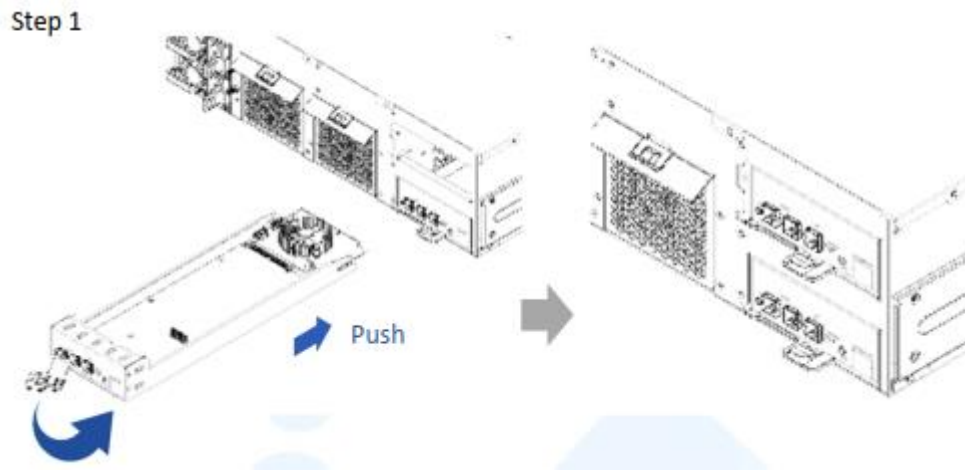

2.5 Rail Installation

SNR-JB series JBOD is a rackmount model, which support EIA-RS310D standard cabinets and chassis racks. Provides standard fixed rails or optional slide rails for mounting the JBOD chassis to cabinets.

2.5.1 The Type of Rail Kit

Please follow the instructions to install the rails on the cabinet or chassis rack according to the rail type you ordered.

2.5.2 Fixed Rails

Step 1: Insert the fixed rail into the rail bracket from the end of the chassis.

Step 2: Tighten the screws to secure the rail and the chassis on the cabinet.

Step 3: Repeat the same action on the other side.

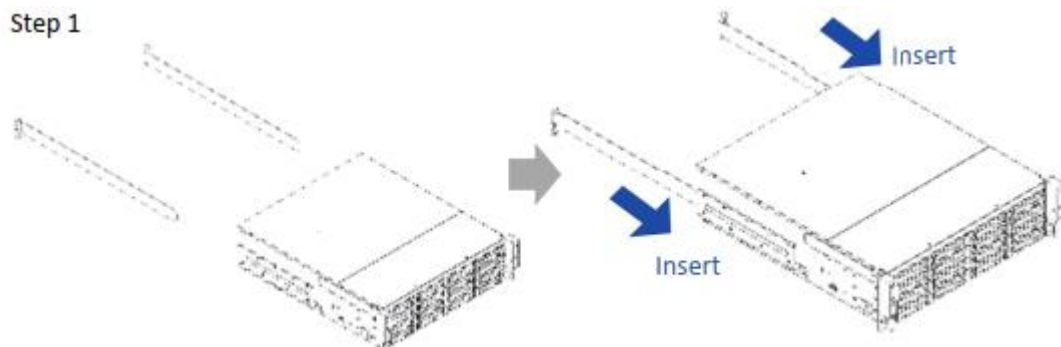



2.5.3 Slide Rail

2.5.3.1 Take out the Inner Rail and Slide the Intermediate Rail Back

Step 1: Pull out the inner rail until it reaches the stop. Release the blue slide tab to unlock.

Step 2: Continue pulling the inner rail until the second stops. Release the white slide tab to remove the inner rail.

Step 3: Pull the latch on the middle rail upward and retract the middle rail back.

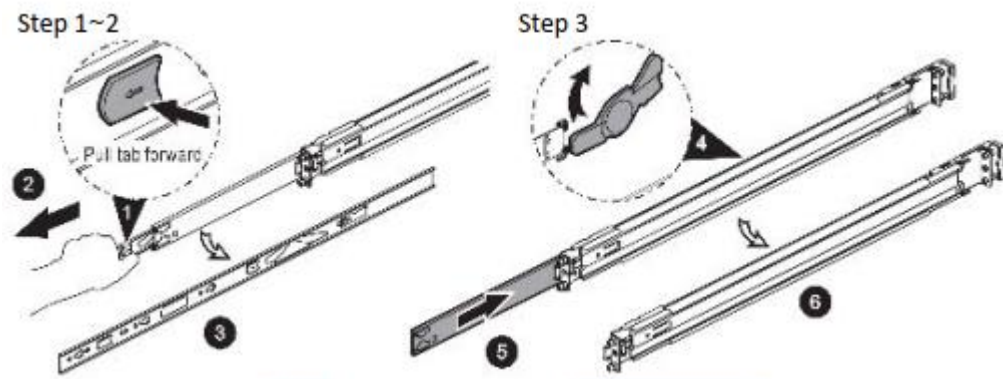

2.5.3.2 Attach the Inner Rail to the Chassis

Step 1: Remove the fixed rail brackets on both sides to reveal the standoffs.

Step 2: Align the chassis sidewall standoffs to the inner rail keyholes. Slide the inner rail toward the front until the standoff snaps into place, securing the rail to the chassis.

Step 3: Repeat the same action on the other side.

Step 4: When removing the inner rail:

Pull up the latch and slide the inner rail forward. Remove the keyhole from the standoff to detach the inner rail. (Action X and Y in the figure)

Step 1

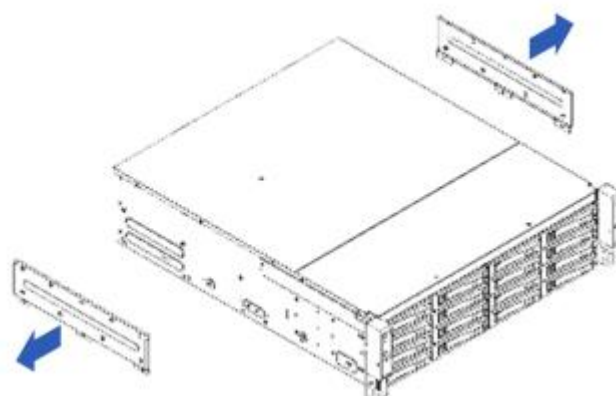

Step 2

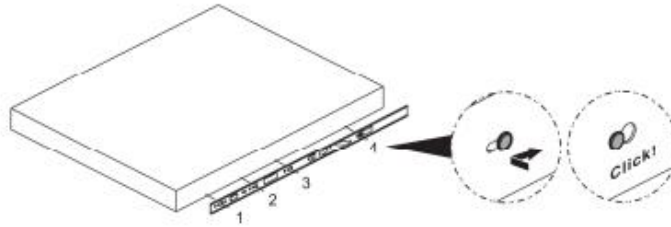

Step 4

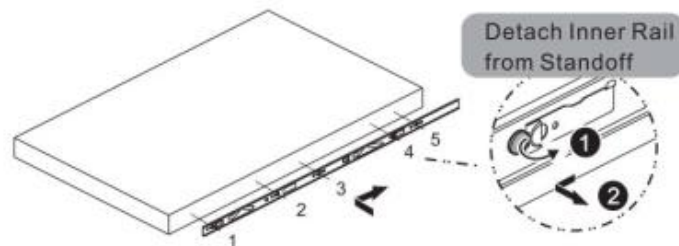

2.5.3.3 Mount the Rail Bracket to the Cabinet

Step 1: Extend the rail bracket over the rear rack of the cabinet.

Step 2: Pull out the rear hook on the end of the outer rail, align and push the rail bracket pins into the post holes on the rack. Then, pull back the hook on the end of the outer rail.

Step 3: Extend the opposite side of the rail bracket to the front rack of the cabinet.

Step 4: Hang the front hooks of the outer rail at the front of the rack post holes. Pull the rail bracket pins that go into the front post holes on the rack until they click.

Step 5: The other side of the rail is symmetrical, repeat the installation steps 1-4.

Step 6: Once you would like to detach the bracket, pull outward on the front and rear hooks of the outer rail to release the bracket.

Repeat the same action to the other side.

Step 1~4

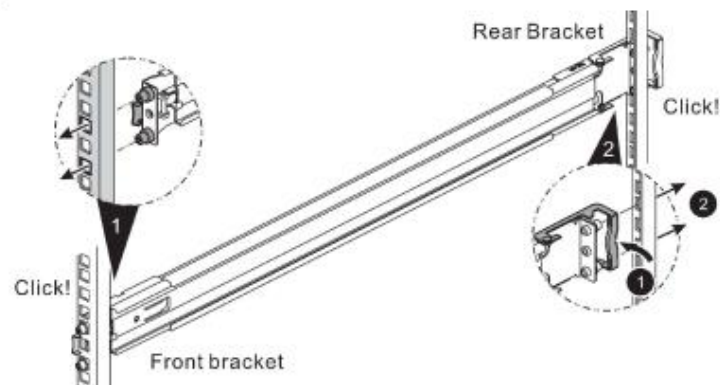



Step 6

Remove bracket

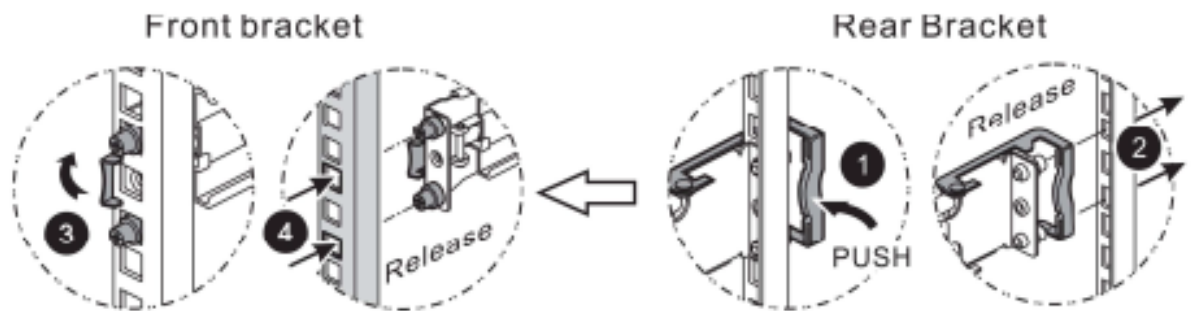

2.5.4 Insert the Chassis to the Cabinet

Step 1: Pull out the middle rail to the stop position.

Step 2: Move the ball bearing retainer to the front end of the middle rail, it should click into the locked position.

Step 3: Insert the inner rails of the chassis into the middle rails on the both sides of the rack.

Step 4: Push the chassis to the stop position, then release the blue slide tab (by either pulling the tab forward or pushing the tab back) to continue.

Step 5: Until reaching the second stop position, release the blue slide tab again to continue.

Step 6: Push the chassis into position on the rack completely. Make sure that the front end of the chassis is aligned with the edge of the rack to complete the installation.

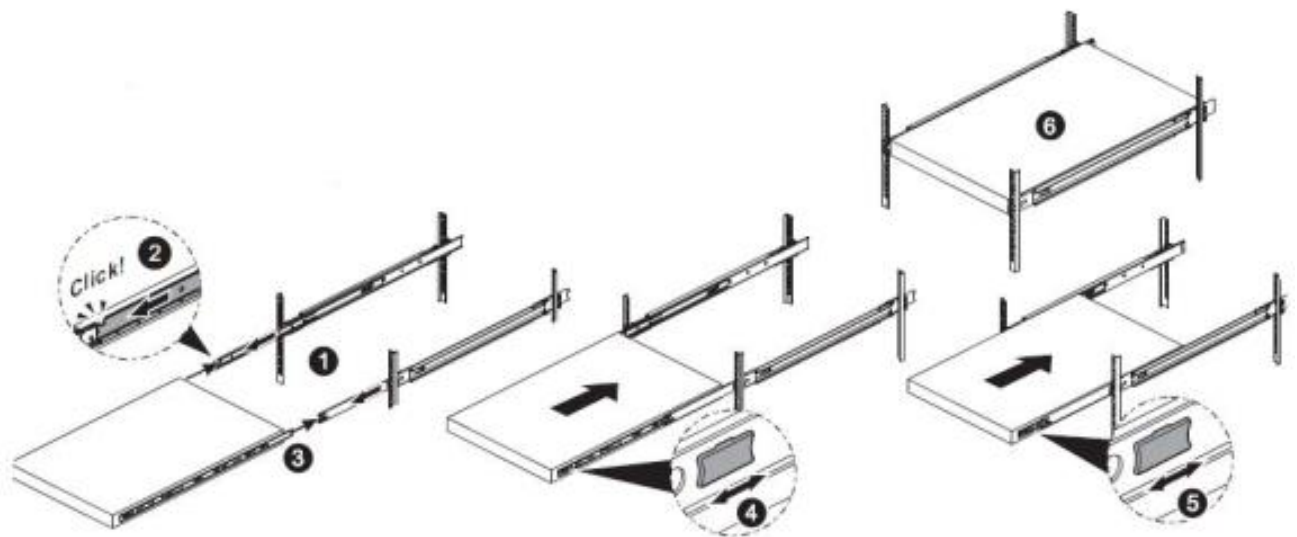



3 Expander Board Introduction

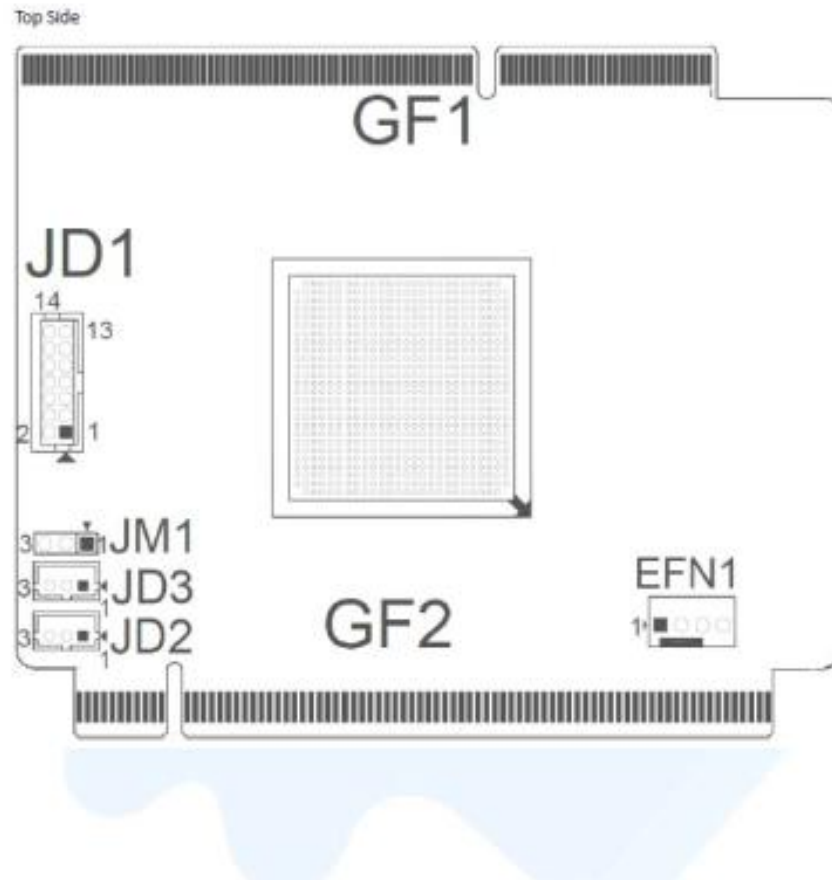

Location	Description
GF1	BP Golden Finger Connector
GF2	IO Board Golden Finger Connector
EFN1	Expander FAN Connector
JM1	Single/Dual Power Module Select: Single: Jumper 1-2; Dual: Jumper 2-3
JD1	ICE Debug Port
JD2	Smart Console
JD3	Debug Port

4 Ethernet Management Card Introduction

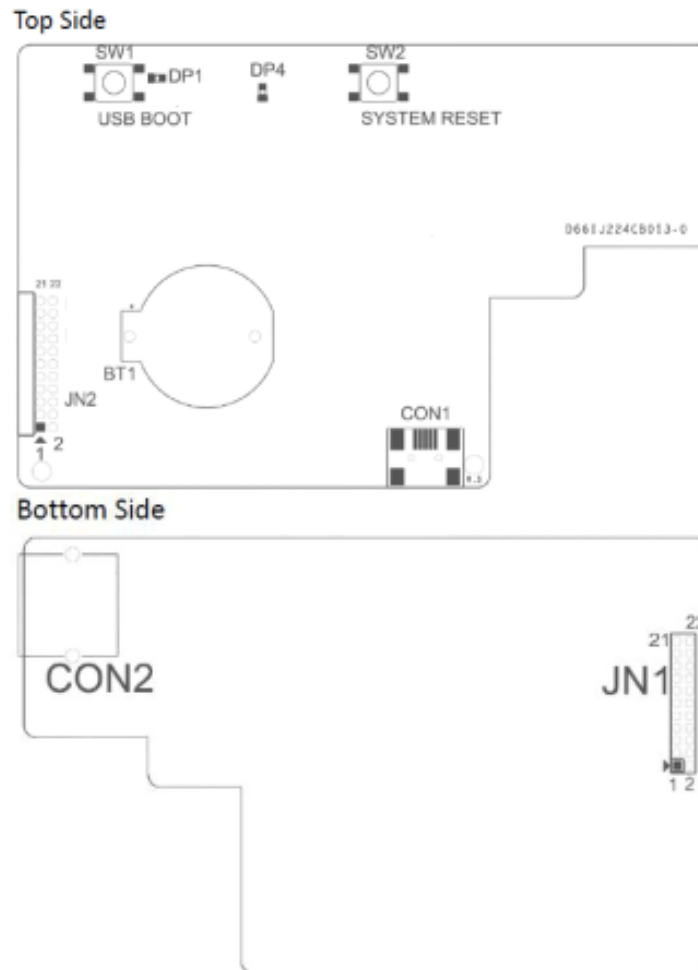

Location	Description
SW1	USB Reboot
SW2	System Reset
DP1	Power LED
DP4	MCU Status LED
JN2	UART Port
CON1	USB Port
JN1	UART Port
CON2	Ethernet Port

5 User Interface Introduction

5.1 Overview

JBOD System is a high performance, reliable storage system with sensors to monitor system health. We provide state-of-the-art management functionality for users to monitor and manage JBOD systems efficiently and flexibly. Users can manage JBOD systems through serial port and/or Ethernet according to the system configuration on the system. We support varieties of network protocols for network management including Telnet, SSH, Web-GUI, SNMP and SMTP. We also support active system alert function by sending information to the email addresses specified in the system, so the users can be informed any changes of the systems in a timely manner.

This users' manual is for all JBOD systems including SNR-JB212D, SNR-JB316D and SNR-JB424D.

provides the information and instruction of frequent use function. Please refer to the table of contents to find the topics.

5.2 Key Features

- Reliable High Data Rate support (up to 12Gbps)
SAS 12Gbps support and SATA3 6Gbps support to provide a reliable high-performance data rate.

- Dual Expanders Support
System can accommodate dual expanders to support data redundancy capability.

- Power Redundancy
System can accommodate 2 PSUs with PMBus as redundancy. Either PSU can work independently while the other is failed.

- Hot-swappable PSU
The hot-swappable PSU doesn't require a system shutdown for PSU replacement in case of a PSU failure.

- Hot-swappable Fan Modules
The hot-swappable fan module doesn't require a system shutdown when swapping modules.

- System Fault Alarm
System Fault red LED indicator on the front panel illuminates and Buzzer sounds while there is system fault.

Buzzer sounds differently according to the system fault. Please see the below the definition:

- High Temperature: 1 short beep
- PSU failure: 2 short beeps
- Fan failure: 3 short beeps

The beeps can be muted by pressing the mute button on the front panel.

- Hot-swappable HDDs

The HDD is hot-swappable. No need to shutdown system for HDD installation and/or replacement while there is HDD failure happens or intend to add new HDD to the system.

- **Smart Fan Control**

The fan modules are smartly controlled by the firmware to provide 7 levels speeds according to the system temperature detected by the temperature sensors on expander chips and Backplane.

- **Zoning**

System support the feature to divide disk drives into 2 different groups. Each group can own users-configurable number of HDDs independently. This feature enables single JBOD serving 2 hosts.

- **Cascading**

There is a cascading port on Expander for cascading another JBOD system to expand disk space whenever the system is running out of space.

5.3 Software Management

5.3.1 System Management Structure

JBOD Systems support out-of-band Network Management feature enabling rich set of protocols and a flexible way for SAS Expander management anytime from anywhere.

5.3.1.1 With Ethernet Management

In this configuration, when there is an Ethernet board on top of the Primary SAS Expander module, users can manage Primary and Secondary SAS expanders through RS-232 port no matter the serial console is connected to Primary or Secondary SAS Expander module.

With proper IP address setting, Users can manage system through Telnet, SSH, Web-GUI and SNMP remotely.

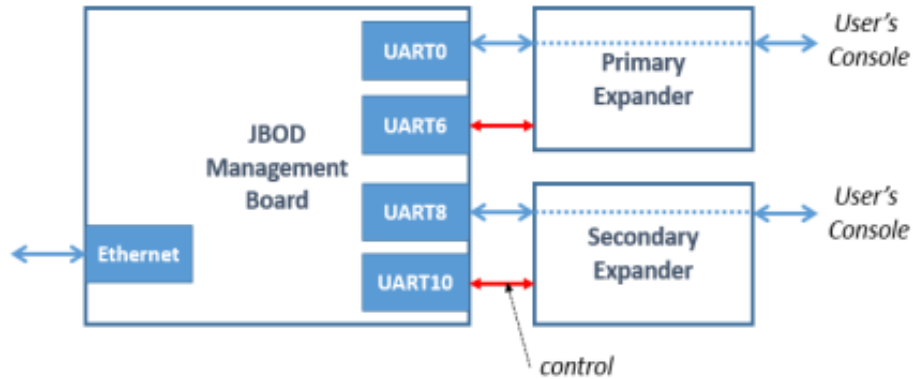
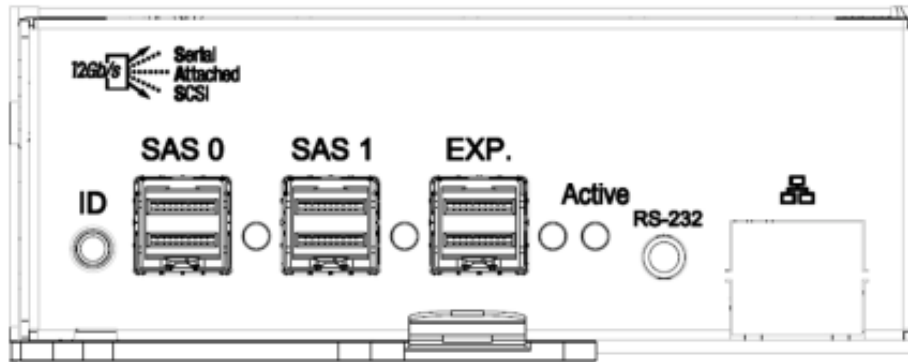

5.3.1.2 Without Ethernet Management

In this configuration, when there is no Ethernet board, Users can only manage Primary or Secondary SAS Expanders by connecting serial console cable to Primary or Secondary SAS Expander module separately. And, in such configuration, Users won't benefit from the rich set of network protocols management.

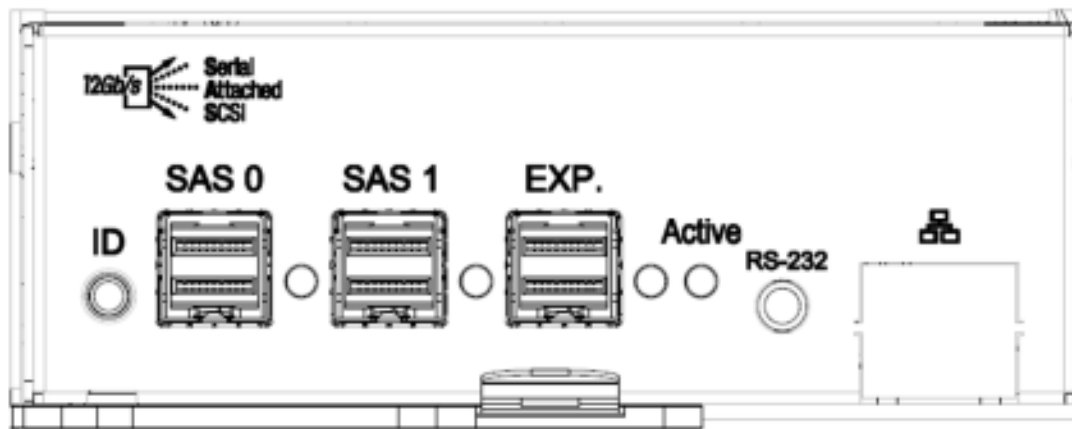

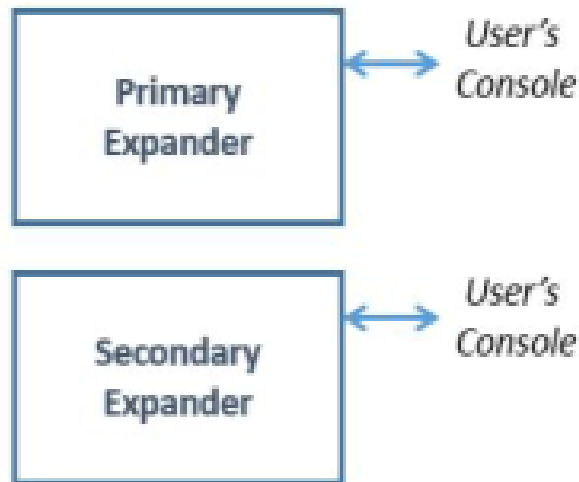

5.3.1.3 Network Protocols Support

As an Ethernet Management board exists, rich set of network protocols are leveraged for flexible remote management. The supported protocols are Telnet, SSH, Web-GUI, SNMP and SMTP.

Please be sure the IP address of the system is correctly configured to enable network management. Our systems support Static IP address or DHCP dynamic IP address as per users' configuration.

5.3.1.4 Operation Modes

JBOD systems Ethernet Management provide a flexibility of modes for different scenarios by simply applying CLI commands to change.

Ethernet management support 2 modes – Normal Mode and Alone Mode.

Normal Mode:

One Ethernet board in a JBOD enclosure. It can be either only one SAS Expander or 2.

In this mode, users can manage both SAS Expander by only one Ethernet board. This is the default operation mode of the Ethernet mgmt. board. To check the operation mode, applying hidden command “save alone” to view. “save alone 0” for Normal mode.

```

/mgmt.s#
/mgmt.s# save alone
Expander mode: 0
/mgmt.s#
/mgmt.s#
/mgmt.s# save alone 0
Expander mode: alone off
/mgmt.s#
/mgmt.s#

```

Whenever the Ethernet mgmt. board run in Normal mode. There are 2 sub-directories “Primary” and “Secondary” being seen and users can change directory to then for SAS Expander management.

```

/mgmt.s#
/mgmt.s# list
?      dns          ipaddr    ntp       primary   secondary  timezone  userdel
date   gateway        mail      passwd   reboot   service    upgrade   userlist
dhcp   help           netmask  ping     save     snap       useradd   version
/mgmt.s#
/mgmt.s# cd primary/
/mgmt.s/primary#
/mgmt.s/primary# list
?      iicw          reset     sys
adcread iicwr        rev       t.Q0
buffsize isrstat      rperw    t.SDP
c_pddl  led          rreg     t.alarm.count
c.syscfg log           rtr      t.ds lot
c.zone  newstat     sasaddr  t.fan
cableinfo mirror       scedebug t.fan.forcespeed
cfg     wr16        serdes info t.fan.simu
clearlogs wr32        sesdebug t.temp.simu
cleartrace wr8         sppio info t.thermal
coredump mw16        spxinfo  thread
counters mw32        showlogs trace
date    mw8         showwfg  tracecap
debuginfo no logs     showpost tracemask
edfinfo phyinfo    showtrace tracesev
encinfo phyop      sapireq  tracetimestamp
eyescope phyttest   sspiinq  wppinfo
flashtblinfo rdcfg     sspir    xocw
help    reg        sspiw
iicr    regerase  ssptdebug
/mgmt.s/primary#

```

Discrete Mode:

Ethernet Board to manage the SAS Expander it resides. There should be Ethernet board on any SAS Expander so it provides Network Management capability.

In this mode, users can manage the SAS Expander the Ethernet board resides on. Users will need 2 Ethernet board to manage both SAS Expander through network.

To check the operation mode, apply hidden command “save alone” in /mgmt.s# layer to view.

```

/mgmt.s#
/mgmt.s#
/mgmt.s# save alone
Expander mode: 1
/mgmt.s#
  
```

To enable the Alone mode, simply apply a hidden command “save alone 1” in /mgmt.s# layer to enable.

```

/mgmt.s#
/mgmt.s#
/mgmt.s# save alone 1
Expander mode: alone on
/mgmt.s#
  
```

To disable the Alone mode (set to Normal mode), simply apply a hidden command “save alone 0” in /mgmt.s# layer to disable.

```

/mgmt.s#
/mgmt.s# save alone 0
Expander mode: alone off
/mgmt.s#
/mgmt.s#
  
```

Please be sure to enable Alone mode on both Ethernet mgmt. boards and do a system reboot so the Alone mode can work properly.

Whenever the Ethernet mgmt. board run in Alone mode. There is only one sub-directory “Expander” can be seen and jump to it for SAS Expander management.

```

/mgmt.s#
/mgmt.s#
/mgmt.s# list
?          dns          help          netmask      ping          service      upgrade      userlist
date       expander  ipaddr       ntp          reboot       snmp         useradd     version
dhcp       gateway  mail        passwd      save         timezone    userdel
/mgmt.s#
/mgmt.s# cd expander/
/mgmt.s/expander# list
?          iicw          reset         sys
adcread   iicwr        rev          t.Q0
buffsize  isrstat     rper        t.SDP
c.pddl    led          rreg        t.alarm.count
c.syscfg  log         rtr         t.dslot
c.zone    newstat     sasaddr     t.fan
cableinfo mirror      scedebg     t.fan.forcespeed
cfg       wr16        serdes info t.fan.simu
clearlogs wr32        sesdebug   t.temp.simu
cleartrace wr8         sgpio info t.thermal
coredump  mw16        sgxinfo    thread
counters  mw32        showlogs   trace
date      mw8         showwfg    tracecap
debuginfo nvlogs     showpost   tracemask
edfinfo   phyinfo    showtrace  tracesev
encinfo   phyop      sapireq    tracetimestamp
eyescope phytest    sspiinq    wppainfo
flashtblinfo rdcfg     sspir      xocw
help      reg        sspiv
iicr      regerase  ssptdebug
/mgmt.s/expander#
  
```

5.3.2 Serial Port Management

RS-232 port on Expander module provides a serial connection for users to manage JBOD system with terminal application such as Tera Term, Hyper Term...etc. To manage JBOD system through serial port, the settings below have to be properly configured to make it work.

Baud Rate : 115200
 Data : 8 bit
 Parity : None
 Stop Bit : 1 bit
 Flow Control : None

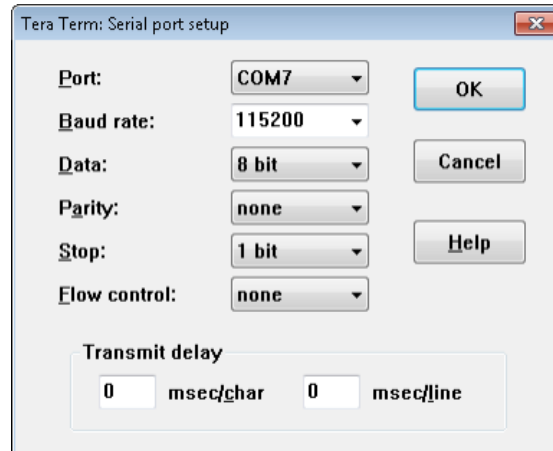

5.3.2.1 CLI

Depending on the system configuration, there are 2 scenarios of CLI usage will be met. One is Expander with Ethernet management board and the other is Expander w/o Ethernet management board.

5.3.2.1.1 Scenario 1: Expander with Ethernet board

As an Ethernet Management board exists, rich set of network protocols are leveraged for flexible remote management. The supported protocols are Telnet, SSH, Web-GUI, SNMP and SMTP.

- “/mgmt.s#” prompts in Console Terminal means the system is with Ethernet board installed which supports Network management with properly configured IP address.
- When “/mgmt.s#” prompts, Users are on the layer of the Ethernet board configuration. Users can configure IP address, manage users account, control services, reboot system...etc. on this layer.
 - “list” command to display all the Ethernet layer commands the system supports.
 - “?” for Help.

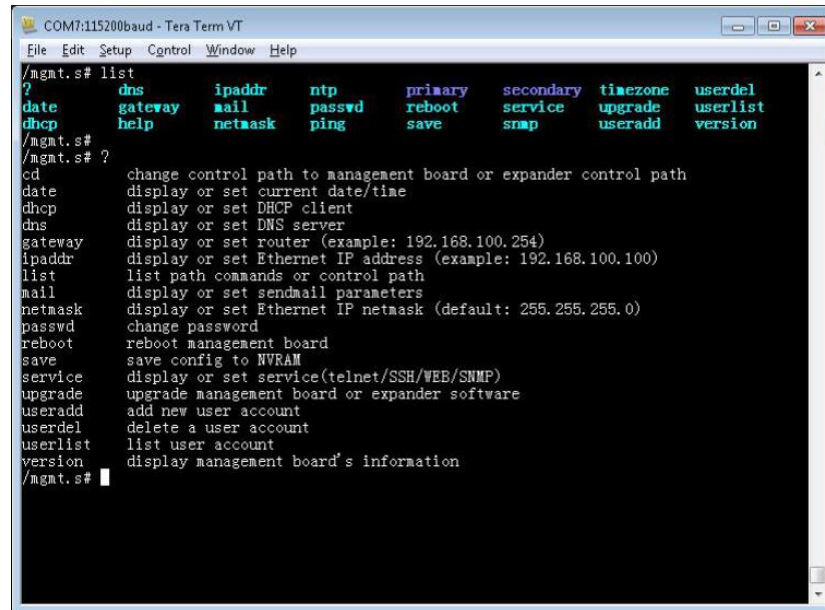

```

COM7:115200baud - Tera Term VT
File Edit Setup Control Window Help
/agnat.s# list
?          dns          ipaddr    ntp       primary  secondary  timezone  userdel
date      gateway  mail      passwd   reboot   service    upgrade   userlist
dhcp      help     netmask   ping     save     snmp       useradd   version
/agnat.s#
/agnat.s# ?
cd          change control path to management board or expander control path
date       display or set current date/time
dhcp      display or set DHCP client
dns        display or set DNS server
gateway    display or set router (example: 192.168.100.254)
ipaddr     display or set Ethernet IP address (example: 192.168.100.100)
list       list path commands or control path
mail       display or set sendmail parameters
netmask    display or set Ethernet IP netmask (default: 255.255.255.0)
passwd     change password
reboot     reboot management board
save       save config to NVRAM
service    display or set service(telnet/SSH/WEB/SNMP)
upgrade    upgrade management board or expander software
useradd    add new user account
userdel    delete a user account
userlist   list user account
version    display management board's information
/agnat.s#
  
```

- “version” command to display system hardware, firmware version information.
- Type “<command>” for displaying the current setting of the specific command.
- Type “<command> ?” for displaying specific command usage.

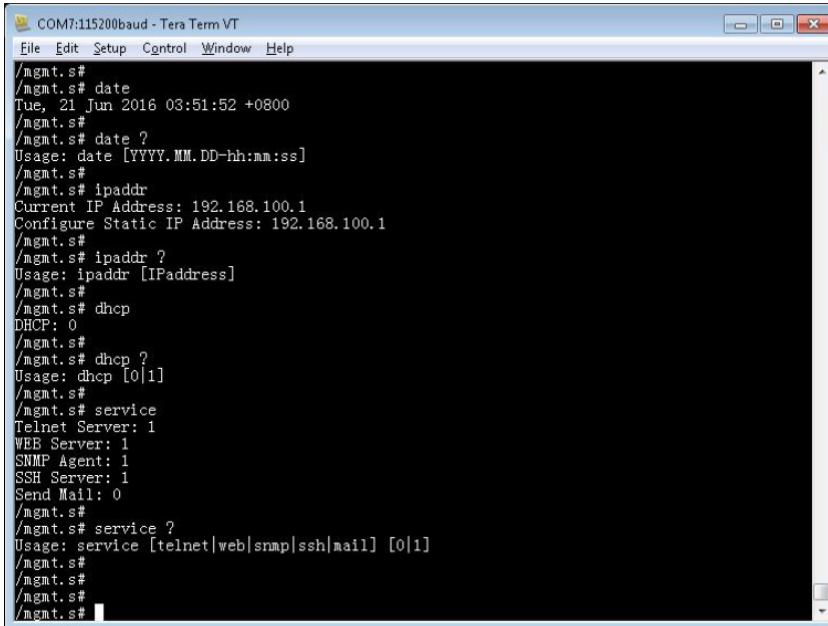

```
COM7:115200baud - Tera Term VT
File Edit Setup Control Window Help
/mgmt.s#
/mgmt.s# date
Tue, 21 Jun 2016 03:51:52 +0800
/mgmt.s#
/mgmt.s# date ?
Usage: date [YYYY.MM.DD-hh:mm:ss]
/mgmt.s#
/mgmt.s# ipaddr
Current IP Address: 192.168.100.1
Configure Static IP Address: 192.168.100.1
/mgmt.s#
/mgmt.s# ipaddr ?
Usage: ipaddr [IPAddress]
/mgmt.s#
/mgmt.s# dhcp
DHCP: 0
/mgmt.s#
/mgmt.s# dhcp ?
Usage: dhcp [0|1]
/mgmt.s#
/mgmt.s# service
Telnet Server: 1
WEB Server: 1
SNMP Agent: 1
SSH Server: 1
Send Mail: 0
/mgmt.s#
/mgmt.s# service ?
Usage: service [telnet|web|snmp|ssh|mail] [0|1]
/mgmt.s#
/mgmt.s#
/mgmt.s#
/mgmt.s#
```

- “cd primary” to change directory for primary expander management.
- “cd ..” to change directory back to upper layer. Usually used on changing from expander layer back to Ethernet layer.
 - “cd secondary” to change directory for secondary expander management.
 - The changes have been made would take effect immediately as the running-config.

- Please be sure to apply “save” command so the changes being made would be saved for use in next reboot as the start-config. Or, the changes would lose.

5.3.2.1.2 Scenario 2: Expander w/o Ethernet board

When there is no Ethernet Board on top of the Primary Expander module users need to connect serial console to Primary or Secondary Expander for managing them separately.

- “bpP >” or “bpS >” prompts in Console Terminal means the system is without Ethernet board installed and no network access support.
- “bpP >” prompts meaning serial console is connecting with Primary Expander.
- “bpS >” prompts meaning serial console is connecting with Secondary Expander.
- “?” or “help” command to display the commands help detailing how to use the console commands. For Example, “rev” to display firmware version, “sys” to display system status, “reset” to reset Expander watch dog.

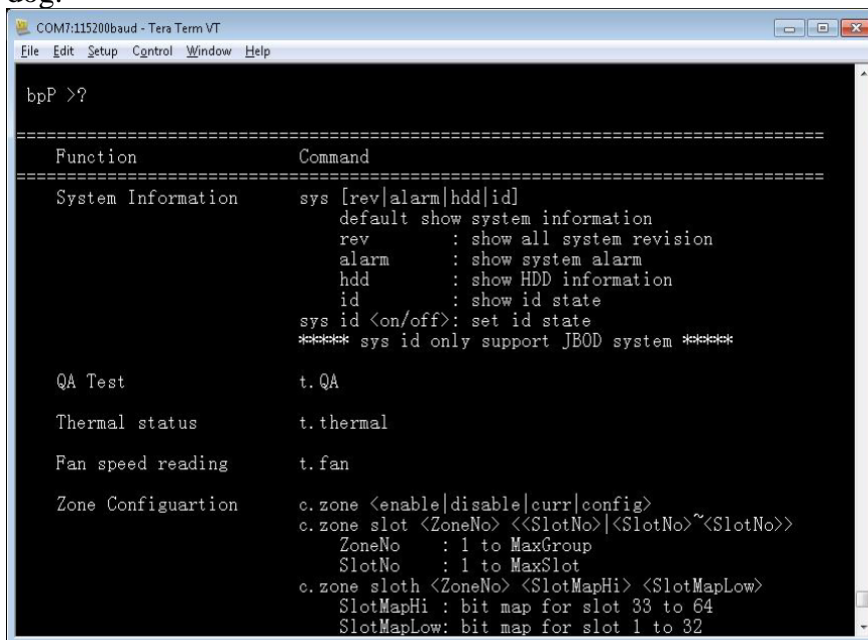

```

COM7:115200baud - Tera Term VT
File Edit Setup Control Window Help

bpP >?

=====
Function          Command
=====
System Information  sys [rev|alarm|hdd|id]
                    default show system information
                    rev       : show all system revision
                    alarm      : show system alarm
                    hdd        : show HDD information
                    id         : show id state
                    sys id <on/off>: set id state
                    ***** sys id only support JBOD system *****

QA Test            t. QA

Thermal status     t. thermal

Fan speed reading  t. fan

Zone Configuration c. zone <enable|disable|curr|config>
c. zone slot <ZoneNo> <<SlotNo>|<SlotNo>~<SlotNo>>
                    ZoneNo    : 1 to MaxGroup
                    SlotNo     : 1 to MaxSlot
c. zone sloth <ZoneNo> <SlotMapHi> <SlotMapLow>
                    SlotMapHi  : bit map for slot 33 to 64
                    SlotMapLow : bit map for slot 1 to 32
  
```

- “? <command>” to display usage of the specific CLI command.



```
COM7:115200baud - Tera Term VT
File Edit Setup Control Window Help

bpP >? sys

=====
Function          Command
=====
System Information  sys [rev|alarm|hdd|id]
                    default show system information
                    rev      : show all system revision
                    alarm    : show system alarm
                    hdd      : show HDD information
                    id       : show id state
                    sys id <on/off>: set id state
                    ***** sys id only support JBOD system *****

=====

bpP >? reset

=====
Function          Command
=====
Reset the expander  reset [watchdog]
=====
```

- Please note that the JBOD systems share the same Expander CLI commands no matter it is with or without Ethernet Management board inside unless otherwise specified.

5.3.3 Network Management

An Ethernet Board is required to support Network management. The Ethernet board sits on top of the Primary Expander module to provide Network Management in various protocols such as Telnet, SSH, Web-GUI, SNMP. It also provides email message sending while there is an alarm occurring by properly configuring the SMTP information.

While there is an Ethernet Board on top of the Primary Expander module it provides a flexible way to manage both Expanders through any physical RS-232 port on either Primary Expander or Secondary Expander by changing directory to /primary or /secondary.

The default setting of the Ethernet board is as below.

IP Address : 192.168.100.1
Subnet mask : 255.255.255.0
Gateway : 192.168.100.254
Username : admin
Password : default

- * Please be sure the management host is in the same IP network domain as the system.
- * Users can make changes of the settings to meet the network environment.
- * For security purposes, we strongly recommend users to change the password immediately after the system is setup online.

5.3.3.1 Telnet

As an Ethernet Management board exists, rich set of network protocols are leveraged for flexible remote management. The supported protocols are Telnet, SSH, Web-GUI, SNMP and SMTP.

- Telnet is default enabled in Ethernet service. It provides the same level of CLI commands as it is through RS-232 console port.
- The difference from serial console is it requires Credential - Username and Password to gain access to Telnet session.

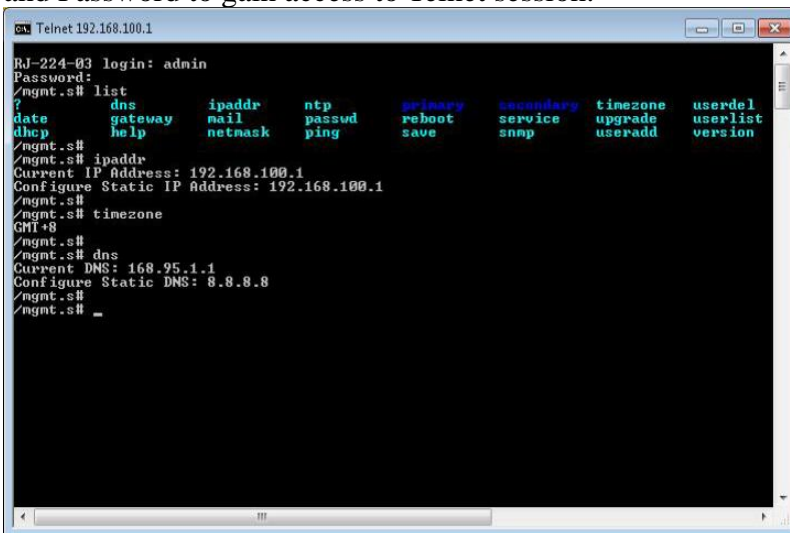

```

Telnet 192.168.100.1
RJ-224-03 login: admin
Password:
/ngmt.s# list
?          dns          ipaddr    ntp       primary   secondary timestone  userdel
date      gateway  mail      passwd    reboot    service   upgrade    userlist
dhcp      help     netmask   ping      save      snmp      useradd    version
/ngmt.s#
/ngmt.s# ipaddr
Current IP Address: 192.168.100.1
Configure Static IP Address: 192.168.100.1
/ngmt.s#
/ngmt.s# timestone
GMT+8
/ngmt.s#
/ngmt.s# dns
Current DNS: 168.95.1.1
Configure Static DNS: 8.8.8.8
/ngmt.s#
/ngmt.s# _
  
```

5.3.3.2 SSH

- SSH is default enabled in Ethernet service. It provides the same level of CLI command as it is through serial console or Telnet session.
- SSH provide a secure connection between host and JBOD system. It is default enabled on most Linux OSes. There are some freeware SSH tools for Windows to use such as Putty, Tera Term, ...etc.
- Below is the Tera Term example to establish SSH session.

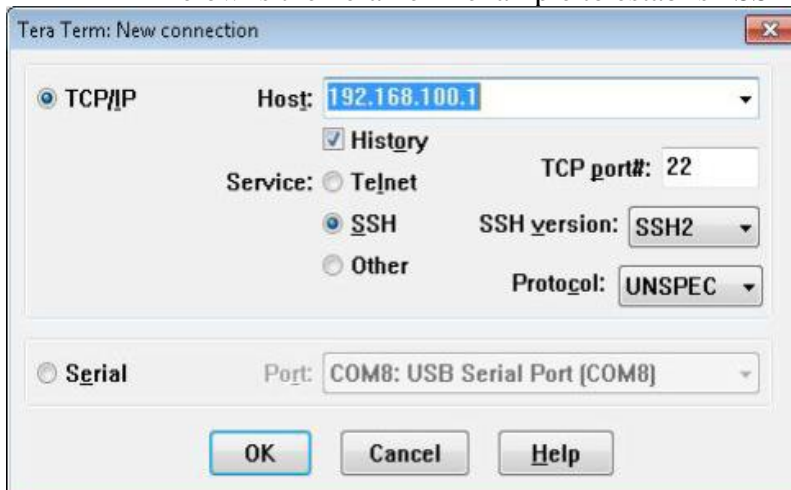

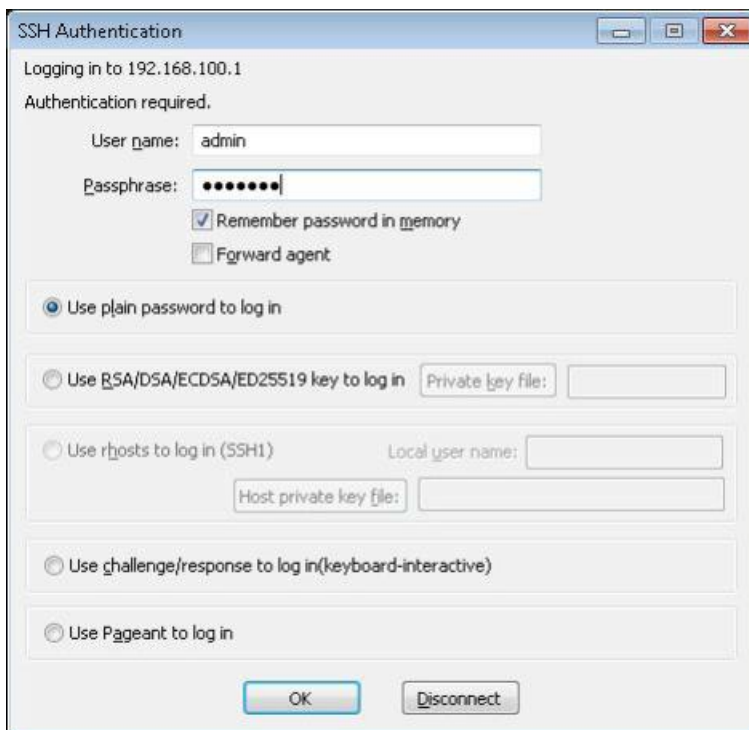
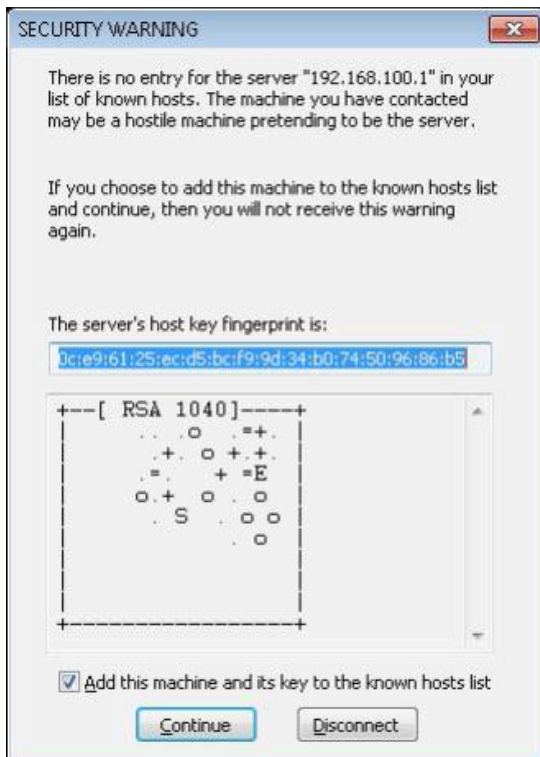

```

192.168.100.1:22 - Tera Term VT
File Edit Setup Control Window Help
/ngmt.s# list
?      dns      ipaddr  ntp     primary secondary timezone use
rdel
date   gateway mail    passwd reboot  service upgrade use
rlist
dhcp   help    netmask ping    save   snmp   useradd ver
sion
/ngmt.s#
/ngmt.s# ?
cd      change control path to management board or expander control path
date    display or set current date/time
dhcp    display or set DHCP client
dns     display or set DNS server
gateway display or set router (example: 192.168.100.254)
ipaddr  display or set Ethernet IP address (example: 192.168.100.100)
list    list path commands or control path
mail    display or set sendmail parameters
netmask display or set Ethernet IP netmask (default: 255.255.255.0)
passwd  change password
reboot  reboot management board
save    save config to NURAM
service display or set service(telnet/SSH/WEB/SNMP)
upgrade upgrade management board or expander software
useradd add new user account
userdel delete a user account
userlist list user account
version display management board's information
/ngmt.s#

```

5.3.3.3 Web UI

- Web-GUI is the easiest way to manage JBOD system. It is default enabled on system.
- Users can simply open Web Browser and giving the JBOD management IP address in URL address field to start accessing system.

Login Page

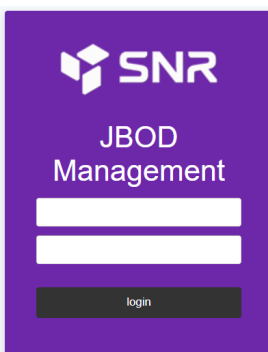

Version Page

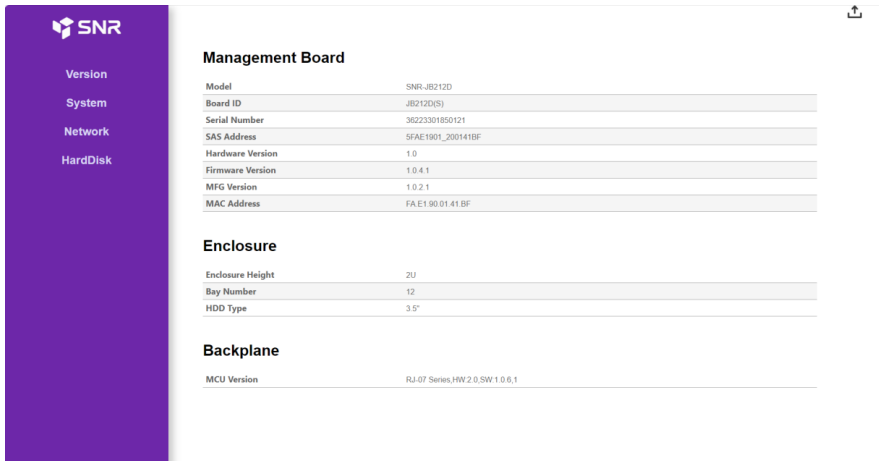

The screenshot shows the 'Version Page' for an SNR device. On the left is a purple sidebar with navigation links: Version (selected), System, Network, and HardDisk. The main content area is white and contains three sections: Management Board, Enclosure, and Backplane. Each section has a table of key-value pairs.

Management Board	
Model	SNR-JB212D
Board ID	JB212D(S)
Serial Number	36223301850121
SAS Address	5FAE1991_200141BF
Hardware Version	1.0
Firmware Version	1.0.4.1
MFG Version	1.0.2.1
MAC Address	FA E1 90 01 41 BF

Enclosure	
Enclosure Height	2U
Bay Number	12
HDD Type	3.5"

Backplane	
MCU Version	RJ-07 Series.HW2.0.SW1.0.6.1

System Page

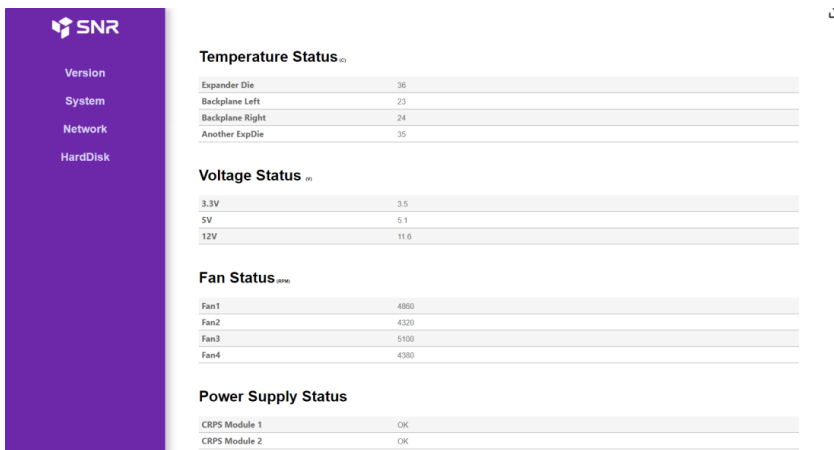

The screenshot shows the 'System Page' for an SNR device. On the left is a purple sidebar with navigation links: Version, System (selected), Network, and HardDisk. The main content area is white and contains four sections: Temperature Status, Voltage Status, Fan Status, and Power Supply Status. Each section has a table of key-value pairs.

Temperature Status	
Expander Die	36
Backplane Left	23
Backplane Right	24
Another ExpDie	35

Voltage Status	
3.3V	3.5
5V	5.1
12V	11.6

Fan Status	
Fan1	4800
Fan2	4320
Fan3	5100
Fan4	4380

Power Supply Status	
CRPS Module 1	OK
CRPS Module 2	OK

5.3.3.4 SNMP

- NMP is a popular network device management protocol that is widely used by IT people to manage systems, devices and equipment which are with SNMP support.
- JBOD system has SNMP agent inside the network management board supporting SNMP v1 and v2c.
- Users need to configure the same read and write community string in JBOD system as the SNMP manager so the system can be managed by the SNMP Manager.

- An IN-WIN proprietary MIB which define system information is required to compile to SNMP Manager so the OID is able to be accessed properly.



inwin-jbod.mib

- SNMP Setting on System
Users can change the setting through CLI and Web-GUI as necessary.

SNMP Manager

Any SNMP Managers can be used to access system information by properly configuring system setting including IP address, Read community string, Write community string to match the setting on system. And compile JBOD MIB file to the manager is necessary. Below an example to browse the system MIB with a free tool.

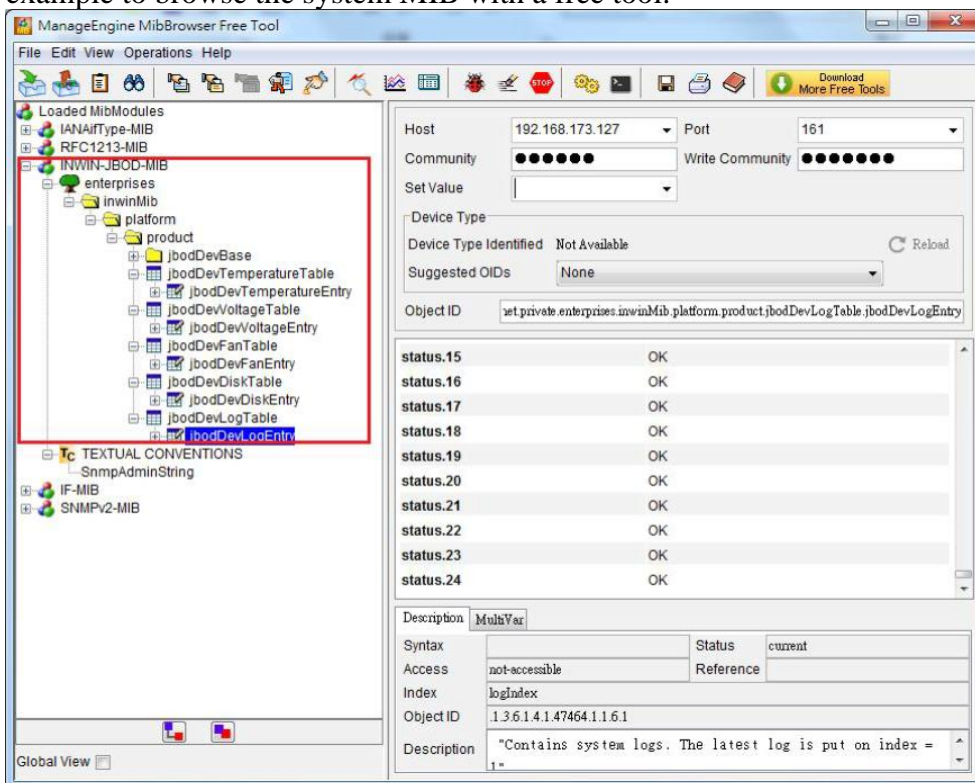

The screenshot shows the ManageEngine MibBrowser Free Tool interface. The left pane displays a tree of loaded MIB modules, with 'INWIN-JBOD-MIB' expanded to show a hierarchy: enterprises > inwinMib > platform > product > jbodDevBase > jbodDevTemperatureTable > jbodDevTemperatureEntry, jbodDevVoltageTable > jbodDevVoltageEntry, jbodDevFanTable > jbodDevFanEntry, jbodDevDiskTable > jbodDevDiskEntry, and jbodDevLogTable > jbodDevLogEntry. The right pane shows configuration for the selected entry (Object ID: set.private enterprises.inwinMib.platform.product.jbodDevLogTable.jbodDevLogEntry). It includes fields for Host (192.168.173.127), Port (161), Community (●●●●●●), and Write Community (●●●●●●). Below these are fields for Device Type (Not Available) and Suggested OIDs (None). A table lists status values from status.15 to status.24, all showing 'OK'. At the bottom, a description field contains the text: 'Contains system logs. The latest log is put on index = 1=

5.3.4 Version Information

Users can check the system hardware and firmware version through various ways.

5.3.4.1 CLI (UART without Ethernet Board)

- “sys rev” display compact Expander hardware, firmware and MFG version.
- “rev” display verbose system version information

```

SECONDARY>rev
=====
Hardware Revision Information:-
=====
Vendor ID       :SNR
Product ID      :J8C120(S)
Product Revision Level :Minor = 0x00, Unit = 0x04
Component Type  :CUBR
Component ID     :0x023b (Bond Option :36)
Component Revision Level :1 (B0)
=====
Firmware Revision Information:-
=====
Active Firmware: Firmware Copy 2

Boot Inape:
Revision: 1.0.3.0
Platform Name:  IN-HIN Cub Expander System
Version Name:   S8355FH-01.00.03.00 05/30/23
Firmware Family: 0 0emFamily: 0
Fast Boot: Yes  Inape Address: 0xd1000000

Firmware Copy 1:
Revision: 1.0.4.1
Platform Name:  IN-HIN Cub Expander System
Version Name:   S8355FH-01.00.04.01 11/20/23
Firmware Family: 0 0emFamily: 0
Fast Boot: Yes  Inape Address: 0xd1180000

Firmware Copy 2:
Revision: 1.0.4.1
Platform Name:  IN-HIN Cub Expander System
Version Name:   S8355FH-01.00.04.01 11/26/23
Firmware Family: 0 0emFamily: 0
Fast Boot: Yes  Inape Address: 0xd1300000

=====
SDK Revision:-
=====
HRL   Revision: 0.16.0.0
SES   Revision: 0.16.0.0
SCE   Revision: 0.16.0.0
Switch Fw Revisions: 0x369 014f
CSLib Revision: 0.0.17.0
=====
Current Toolchain Revision:-
=====
ARM RVD5 v_410713

```

5.3.4.2 CLI (UART, Telnet and SSH with Ethernet Board)

- Type “version” command on Ethernet Layer to display all the version information including Ethernet firmware version, Expander HW version, Expander firmware version and MFG CFG file version.

- To check SAS Expander versions only, users can change directory to Expander layer and type “sys rev” command to check Expander version information.

5.3.4.3 Web-GUI

- Type system IP address on Web Browser URL address field to gain access to the system. After logging in, click “Version” button on the left pane to view the system version information on the right pane. Scroll down to view all information if the display is out of page.





Version
System
Network
HardDisk

Management Board

Model	SNR-JB212D
Board ID	JB212D(S)
Serial Number	36223301850121
SAS Address	5FAE1901_200141BF
Hardware Version	1.0
Firmware Version	1.0.4.1
MFG Version	1.0.2.1
MAC Address	FA E1 90 01 41 BF

Enclosure

Enclosure Height	2U
Bay Number	12
HDD Type	3.5"

Backplane

MCU Version	RJ-07 Series,HW 2.0,SW 1.0.6.1
-------------	--------------------------------

5.3.5 System Status

System Status is to display the status of the system sensors including temperature, voltage, fan speed and Power Supply.

There are 1 temperature sensor on each Expander, 2 system temperature sensors on Backplane, 5V and 12V voltage sensors on backplane, 4 Fan speed sensors on backplane and 2 Power Supply health sensors on PDB.

5.3.5.1 CLI (UART without Ethernet Board)

- Type “sys alarm” on console to check the system sensor’ s readings and their status.
- Connect serial cable to Primary and Secondary Expander to check the status respectively. As the design, both Primary and Secondary Expanders would get the same reading and status (except Exp Die Temperature) since they are from the same sensors.

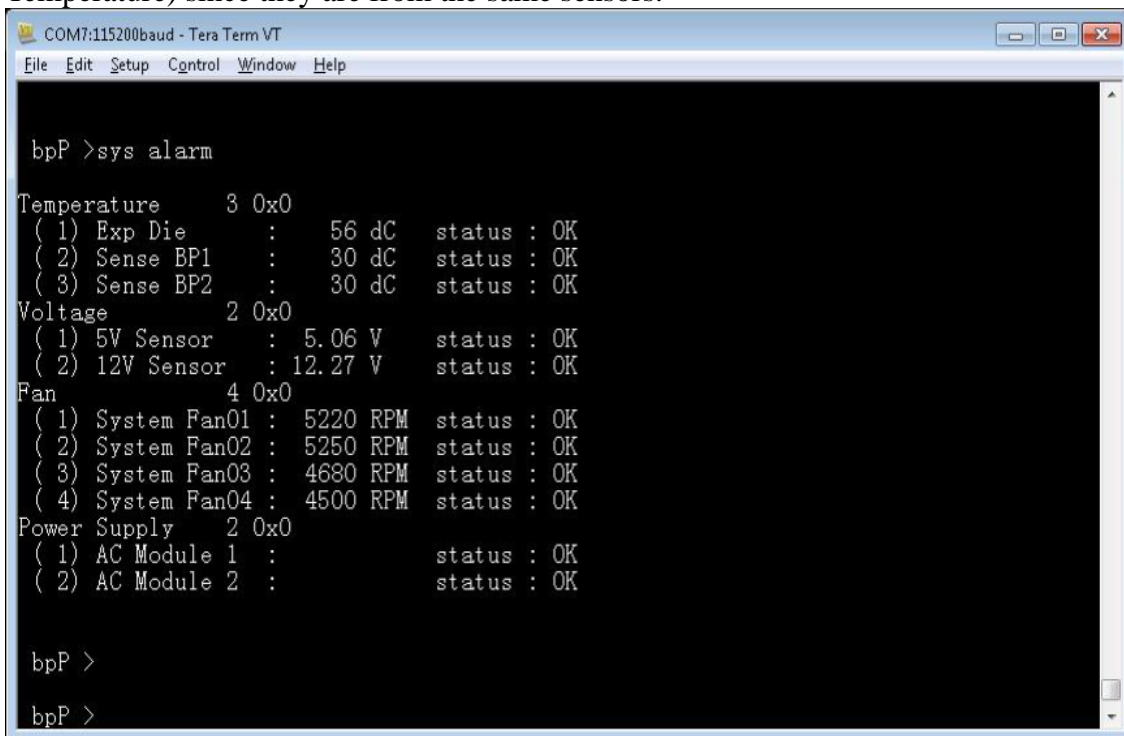

```

COM7:115200baud - Tera Term VT
File Edit Setup Control Window Help

bpP >sys alarm

Temperature      3 0x0
( 1) Exp Die    :   56 dC  status : OK
( 2) Sense BP1  :   30 dC  status : OK
( 3) Sense BP2  :   30 dC  status : OK
Voltage          2 0x0
( 1) 5V Sensor  :   5.06 V  status : OK
( 2) 12V Sensor :  12.27 V  status : OK
Fan              4 0x0
( 1) System Fan01 : 5220 RPM status : OK
( 2) System Fan02 : 5250 RPM status : OK
( 3) System Fan03 : 4680 RPM status : OK
( 4) System Fan04 : 4500 RPM status : OK
Power Supply     2 0x0
( 1) AC Module 1 :          status : OK
( 2) AC Module 2 :          status : OK

bpP >
bpP >
  
```

5.3.5.2 CLI (UART, Telnet and SSH with Ethernet Board)

- Type “sys alarm” command on Expander layer would display the System sensors’ reading and their status.
- Please note that the Expander temperature sensor “Exp Die” is located on the Expander chip so need to change directory to Primary and Secondary to read its status respectively.

```

Telnet 192.168.173.127
/mgmt.s# cd primary/
/mgmt.s/primary# sys alarm
sys alarm

Temperature      3 0x0
( 1) Exp Die    : 69 dC  status : OK
( 2) Sense BP1  : 30 dC  status : OK
( 3) Sense BP2  : 30 dC  status : OK
Voltage          2 0x0
( 1) 5V Sensor  : 4.98 V  status : OK
( 2) 12V Sensor : 12.20 V  status : OK
Fan              4 0x8
( 1) System Fan01 : 4920 RPM status : OK
( 2) System Fan02 : 4860 RPM status : OK
( 3) System Fan03 : 5550 RPM status : OK
( 4) System Fan04 : 0 RPM   status : Critical
Power Supply     2 0x0
( 1) AC Module 1 :          status : OK
( 2) AC Module 2 :          status : OK

/mgmt.s/primary# cd ..
/mgmt.s# cd secondary/
/mgmt.s/secondary# sys alarm
sys alarm

Temperature      3 0x0
( 1) Exp Die    : 66 dC  status : OK
( 2) Sense BP1  : 30 dC  status : OK
( 3) Sense BP2  : 30 dC  status : OK
Voltage          2 0x0
( 1) 5V Sensor  : 4.98 V  status : OK
( 2) 12V Sensor : 12.20 V  status : OK
Fan              4 0x8
( 1) System Fan01 : 4920 RPM status : OK
( 2) System Fan02 : 4860 RPM status : OK
( 3) System Fan03 : 5550 RPM status : OK
( 4) System Fan04 : 0 RPM   status : Critical
Power Supply     2 0x0
( 1) AC Module 1 :          status : OK
( 2) AC Module 2 :          status : OK

/mgmt.s/secondary#

```

5.3.5.3 Web-GUI

- Type system IP address on Web Browser URL field to gain access to the system. After logging in, click “System” button on the left pane to view the system status information on the right pane. Scroll down to view all information if the display is out of page.

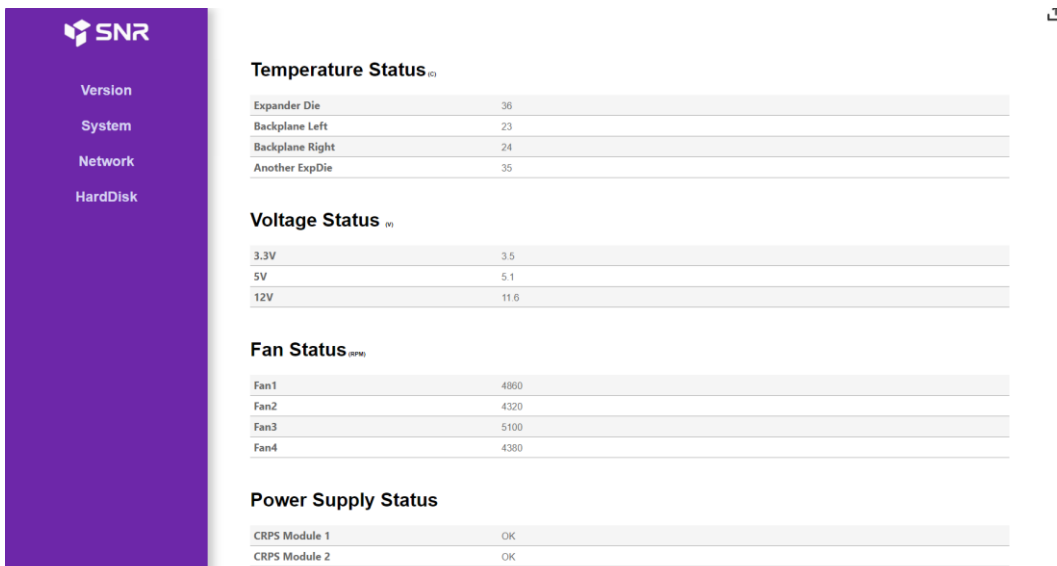

The screenshot shows the SNR Web-GUI interface. On the left is a purple sidebar with navigation options: Version, System, Network, and HardDisk. The main content area displays system status information in four sections:

- Temperature Status**: A table with 4 rows showing temperature readings for Expander Die, Backplane Left, Backplane Right, and Another ExpDie.
- Voltage Status**: A table with 3 rows showing voltage readings for 3.3V, 5V, and 12V.
- Fan Status**: A table with 4 rows showing fan speeds for Fan1, Fan2, Fan3, and Fan4.
- Power Supply Status**: A table with 2 rows showing the status of CRPS Module 1 and CRPS Module 2.

.3.6 Network Settings

Network settings is for displaying and setting the system network information including Current Network Status, DHCP/Static IP Address selection, Network Services, Mail configuration, SNMP configuration.

5.3.6.1 CLI (UART, Telnet and SSH with Ethernet Board)

- There are a couple network setting commands on Ethernet layer such as “ipaddr”, “gateway”, “netmask”, ...etc. to view and configure the setting respectively. Please refer to Management\CLI session for more details in how to use the CLI commands.
- Please be sure to apply “save” command so the setting would be saved for next system reboot.

5.3.6.2 Web-GUI

- Type system IP address on Web Browser URL field to gain access to the system. After logging in, click “Network” button on the left pane to view the network information on the right pane. Scroll down to view all information if the display is out of page.

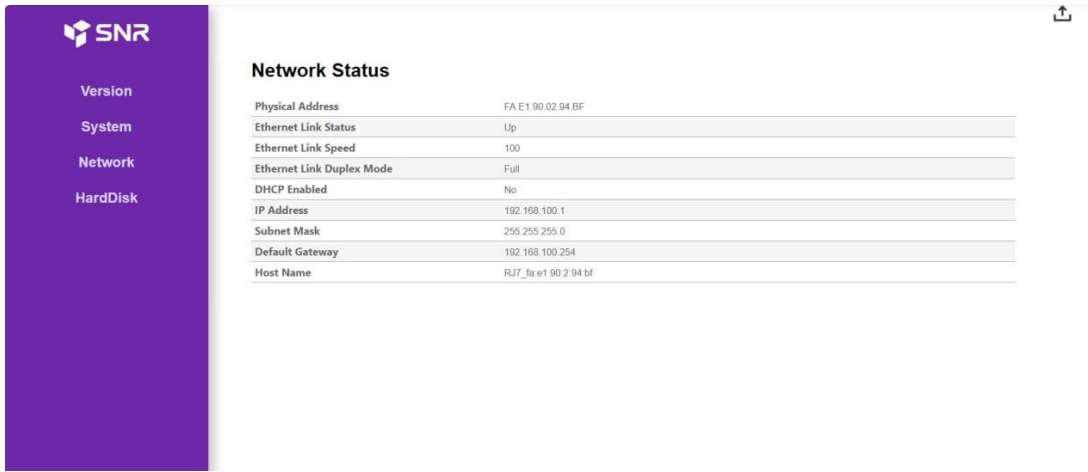

5.3.7 Disk Information

Disk information is to show the disk drives status on the system including Bay id, Phy id, SAS Address, Link speed and current status.

5.3.7.1 CLI (UART without Ethernet Board)

- Type “sys hdd” command to display the system hard disk drives status on the system.

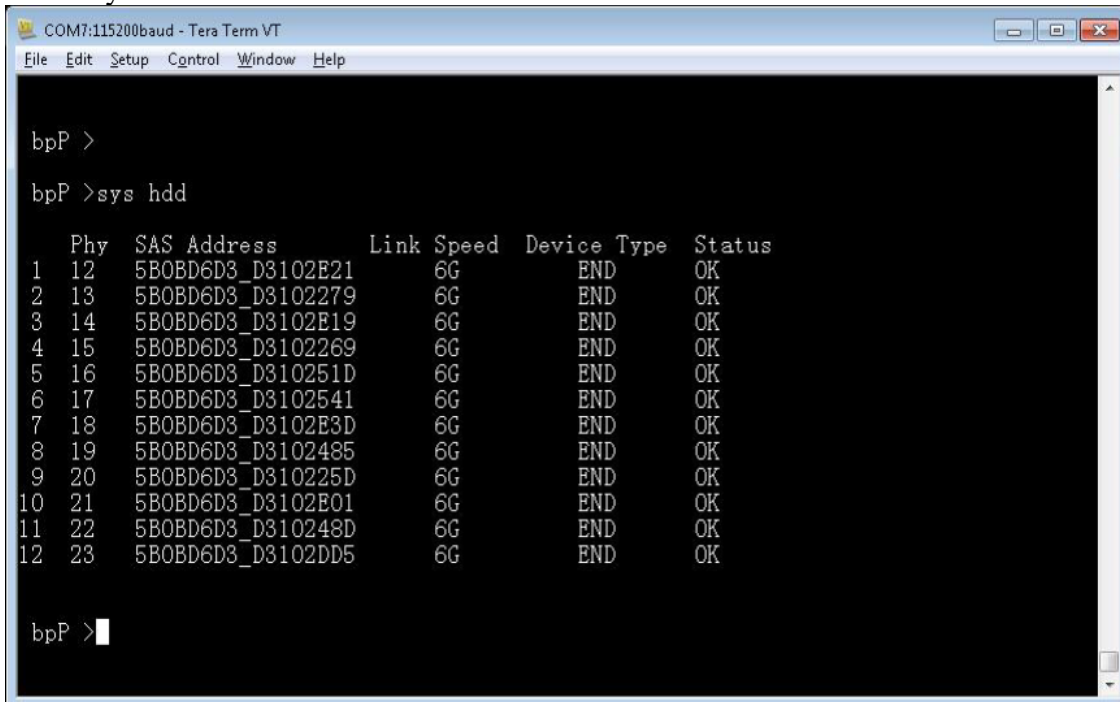

5.3.7.2 CLI (UART, Telnet and SSH with Ethernet Board)

- Type “sys hdd” command on Expander layer would display the system hard disk drives status on the system.

```

c:\ Telnet 192.168.173.127
/mgmt.s# cd primary
/mgmt.s/primary#
/mgmt.s/primary# sys hdd
sys hdd

   Phy  SAS Address      Link Speed  Device Type  Status
  ---  -
1  12  5B0BD6D3_D3102A31    6G          END         OK
2  13  5B0BD6D3_D3102A89    6G          END         OK
3  14  5B0BD6D3_D3102B71    6G          END         OK
4  15  5B0BD6D3_D31023E9    6G          END         OK
5  16  5B0BD6D3_D3102891    6G          END         OK
6  17  5B0BD6D3_D3102BA5    6G          END         OK
7  18  5B0BD6D3_D310211D    6G          END         OK
8  19  5B0BD6D3_D31020FD    6G          END         OK
9  20  5B0BD6D3_D3102ACD    6G          END         OK
10 21  5B0BD6D3_D310212D    6G          END         OK
11 22  5B0BD6D3_D3102145    6G          END         OK
12 23  5B0BD6D3_D3102A85    6G          END         OK
13 24  5B0BD6D3_D3102ADD    6G          END         OK
14 25  5B0BD6D3_D3102239    6G          END         OK
15 26  5B0BD6D3_D31029DD    6G          END         OK
16 27  5B0BD6D3_D3102A19    6G          END         OK
17 32  5B0BD6D3_D3102AE1    6G          END         OK
18 33  5B0BD6D3_D3102B8D    6G          END         OK
19 34  5B0BD6D3_D310290D    6G          END         OK
20 35  5B0BD6D3_D31028A1    6G          END         OK
21 28  5B0BD6D3_D3102869    6G          END         OK
22 29  5B0BD6D3_D31023ED    6G          END         OK
23 30  5B0BD6D3_D31023BD    6G          END         OK
24 31  5B0BD6D3_D31028C1    6G          END         OK

/mgmt.s/primary#

```

5.3.7.3 Web-GUI

- Type system IP address on Web Browser URL field to gain access to the system. After logging in, click “Disk” button on the left pane to view the disk drives information on the right pane. Scroll down to view all information if the display is out of page.



SNR

- Version
- System
- Network
- HardDisk**



Disk Slot Status

Bay#	PHY ID	Link	Disk Type
1	0		
2	0		
3	0		
4	0		
5	0		
6	0		
7	0		
8	0		
9	0		
10	0		
11	0		
12	0		

5.3.8 Zone Setting

5.3.8.1 CLI (UART without Ethernet Board)

5.3.8.1.1 Type “c.zone curr” command to show the current zone running setting.

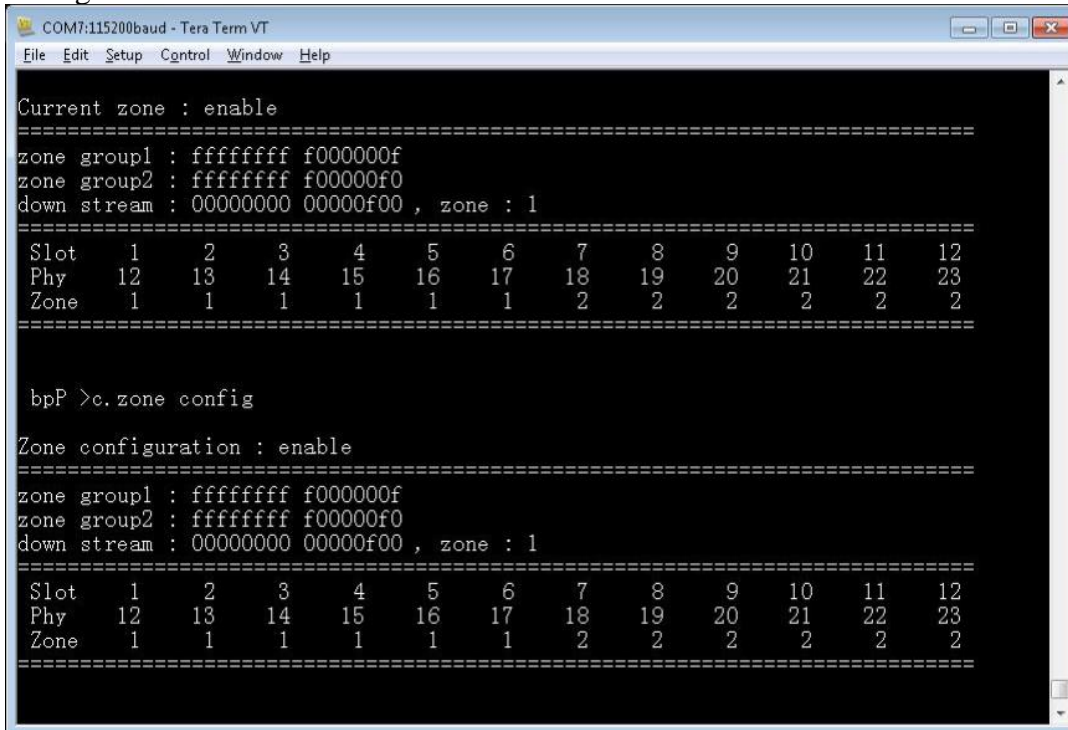

```

COM7:115200baud - Tera Term VT
File Edit Setup Control Window Help

Current zone : enable
=====
zone group1 : ffffffff f000000f
zone group2 : ffffffff f00000f0
down stream : 00000000 00000f00 , zone : 1
=====
Slot   1    2    3    4    5    6    7    8    9   10   11   12
Phy   12   13   14   15   16   17   18   19   20   21   22   23
Zone   1    1    1    1    1    1    2    2    2    2    2    2
=====

bpP >c.zone config

Zone configuration : enable
=====
zone group1 : ffffffff f000000f
zone group2 : ffffffff f00000f0
down stream : 00000000 00000f00 , zone : 1
=====
Slot   1    2    3    4    5    6    7    8    9   10   11   12
Phy   12   13   14   15   16   17   18   19   20   21   22   23
Zone   1    1    1    1    1    1    2    2    2    2    2    2
=====

```

5.3.8.1.2 Type “c.zone slot 1 1~6” to configure Zone 1 containing Slot 1 to Slot 6 disk drives.

5.3.8.1.3 Type “c.zone config” to show the zone configuration the users have made.

5.3.8.1.4 Type “c.zone down 1” to configure the Exp. Port of the 3 SAS ports belonging to zone group 1.

5.3.8.1.5 Type “c.zone enable” to enable Zoning setting of the system.

5.3.8.1.6 Type “c.zone disable” to disable Zoning setting of the system.

5.3.8.1.7 A system reboot is required to make the Zone configuration take effect.

5.3.8.1.8 Please note that the Zoning setting is only made for the expander the serial port is currently connected. To make both expander, please do it again on other Expander.

5.3.8.2 CLI(UART, Telnet and SSH with Ethernet Board)

5.3.8.2.1 Type “c.zone curr” command on Expander layer would display the current zone running setting.



```
Telnet 192.168.173.112

/mgmt.s/primary# ? c.zone
? c.zone

=====
Function                Command
=====
Zone Configuration      c.zone <enable|disable|curr|config>
                        c.zone slot <ZoneNo> <<SlotNo>|<SlotNo>~<SlotNo>>
                        ZoneNo      : 1 to MaxGroup
                        SlotNo       : 1 to MaxSlot
                        c.zone sloth <ZoneNo> <SlotMapHi> <SlotMapLow>
                        SlotMapHi    : bit map for slot 33 to 64
                        SlotMapLow   : bit map for slot 1 to 32
                        c.zone down <ZoneNo>
                        set downstream zone
                        ***** zone only support JBOD system *****

=====

/mgmt.s/primary# c.zone curr
c.zone curr

Current zone : enable

=====
zone group1 : ffffffff f000000f
zone group2 : ffffffff f00000f0
down stream : 00000000 00000f00 , zone : 1

=====
Slot  1    2    3    4    5    6    7    8    9   10   11   12
Phy   12   13   14   15   16   17   18   19   20   21   22   23
Zone  2    2    2    2    2    2    2    1    1    1    1    1

=====

/mgmt.s/primary#
```

5.3.8.2.2 Type “c.zone slot 1 1~6” to configure Zone 1 containing Slot 1 to Slot 6 disk drives.

5.3.8.2.3 Type “c.zone config” to show the current zoning configuration. A system reboot is required to make the configuration take effect.

5.3.8.2.4 Type “c.zone down 1” to configure the Exp. Port of the 3 SAS ports belonging to zone group 1.

5.3.8.2.5 Type “c.zone enable” to enable Zoning setting of the system.

5.3.8.2.6 Type “c.zone disable” to disable Zoning setting of the system.

5.3.8.2.7 A system reboot is required to make the Zone configuration take effect.

5.3.8.2.8 Please note that the Zoning setting is only made for the expander the console is currently on. To make both expander, please do it again on other Expander.

```

Telnet 192.168.173.112
/mgmt.s/primary# c.zone disable
c.zone disable
Disable zone ...

/mgmt.s/primary# c.zone enable
c.zone enable
Enable zone ...

/mgmt.s/primary# c.zone slot 1 1~6
c.zone slot 1 1~6
Set slot1 ~ slot6 ZoneNo = 1 ...

/mgmt.s/primary# c.zone down 1
c.zone down 1
Set downstream ZoneNo = 1 ...

/mgmt.s/primary# c.zone config
c.zone config
Zone configuration : enable
=====
zone group1 : ffffffff f000000f
zone group2 : ffffffff f00000f0
down stream : 00000000 00000f00 , zone : 1
=====
Slot  1   2   3   4   5   6   7   8   9  10  11  12
Phy  12  13  14  15  16  17  18  19  20  21  22  23
Zone  1   1   1   1   1   1   2   2   2   2   2   2
=====
/mgmt.s/primary#

```

5.3.8.3 Web-GUI

5.3.8.3.1 Type system IP address on Web Browser URL field to gain access to the system. After logging in, click “Zone” button on the left pane to view and configure the Zoning setting of the system.

5.3.8.3.2 “Current Zone Configuration” session shows the current zone setting on the system including the disk bay assignment of zone and the cascading port zone group.

5.3.8.3.3 “New Zone Configuration” session allow users to configure zone setting on the system in an easy way by selecting the disk bays and the zone group the cascading port belonging to. Click “Apply” to make the configuration take effect.

5.3.8.3.4 Whenever there are 2 SAS Expanders on the system, the Zoning setting applies to both while configuring through Web-GUI.

5.3.9 Firmware Upgrade

Firmware upgrade function provides a way to update system firmware when necessary.

There are 3 firmware for JBOD system:

1. Ethernet Management Board Firmware (when there is Ethernet management board)
2. SAS Expander Board Firmware
3. SAS Expander MFG CFG binary

There are a couple ways to upgrade system firmware according to the HW configurations. Please note that the upgraded firmware won't take effect immediately until a system reboot.

5.3.9.1 CLI (UART without Ethernet Board)

When there is no Ethernet Management board on the system users can upgrade SAS Expander firmware and MFG CFG file through Xmodem protocol. Most of serial console terminal tools such as Tera Term support Xmodem protocol for sending file to system.

The Firmware upgrade has to be done on both the Primary and Secondary SAS Expander separately whenever there is a Secondary SAS Expander on the system.

5.3.9.1.1 SAS Expander Firmware

- A. "fwdl" command on serial console.
- B. Type "y" to commit firmware upgrade.

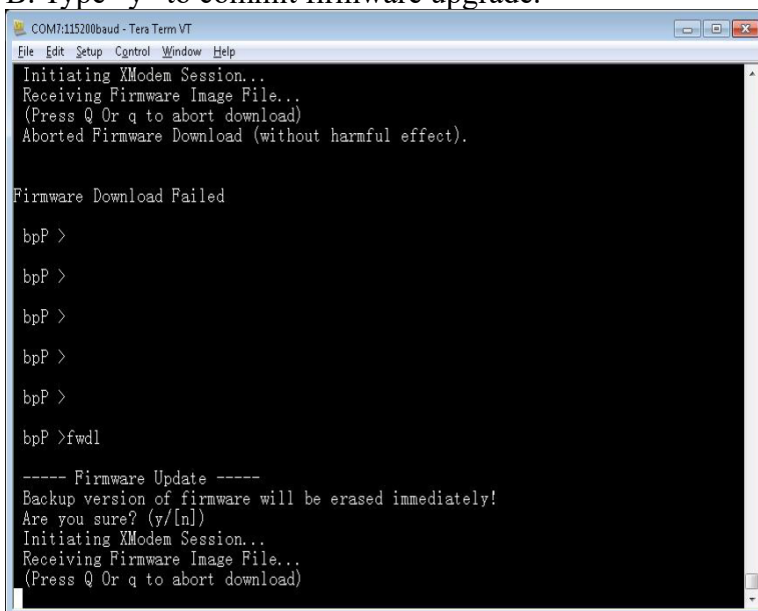

```

COM7:115200baud - Tera Term VT
File Edit Setup Control Window Help
Initiating XModem Session...
Receiving Firmware Image File...
(Press Q Or q to abort download)
Aborted Firmware Download (without harmful effect).

Firmware Download Failed

bpP >
bpP >
bpP >
bpP >
bpP >
bpP >fwdl

----- Firmware Update -----
Backup version of firmware will be erased immediately!
Are you sure? (y/[n])
Initiating XModem Session...
Receiving Firmware Image File...
(Press Q Or q to abort download)
  
```

- C. Select xmodem as the protocol to transfer file.

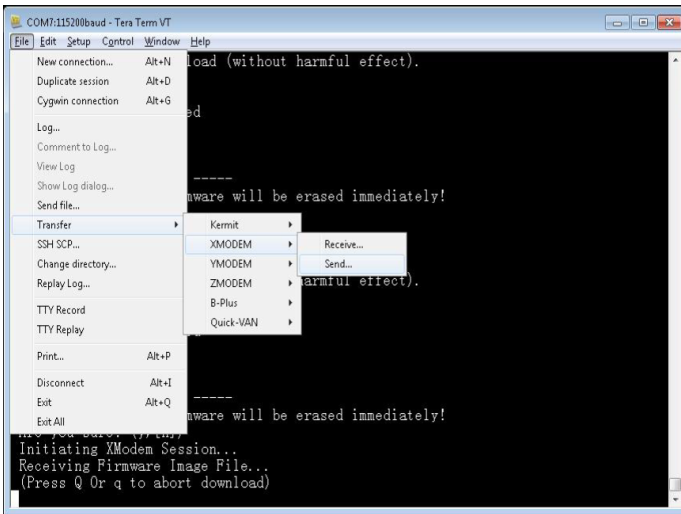

- D. Select the correct SAS Expander firmware file.
- E. Click on “Open” to start the selected firmware transferring to SAS Expander.

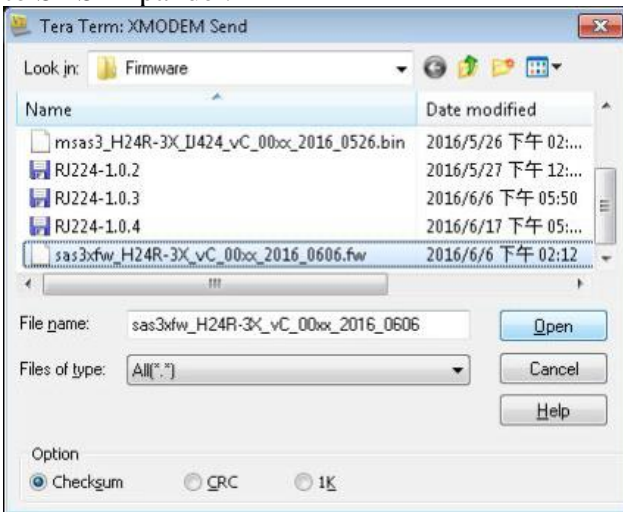

- F. Serial console would then start firmware transfer.

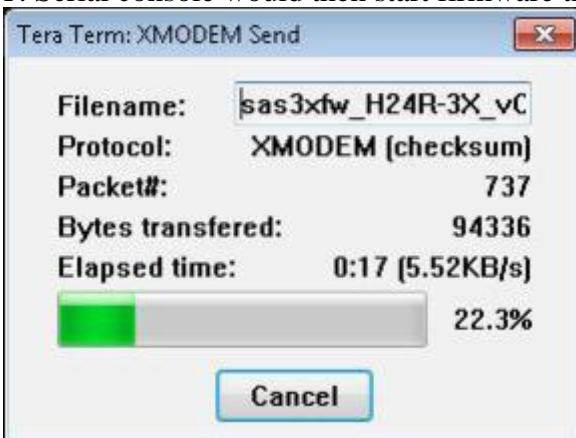

G. After firmware transfer completed, reboot Expander to activate new firmware.

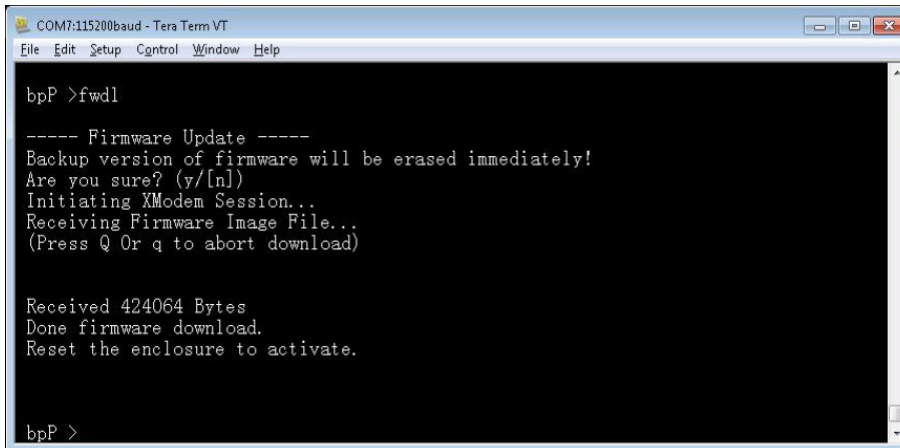

```

COM7:115200baud - Tera Term VT
File Edit Setup Control Window Help

bpP >fwdl

----- Firmware Update -----
Backup version of firmware will be erased immediately!
Are you sure? (y/[n])
Initiating XModem Session...
Receiving Firmware Image File...
(Press Q Or q to abort download)

Received 424064 Bytes
Done firmware download.
Reset the enclosure to activate.

bpP >
  
```

5.3.9.1.2 SAS Expander MFG CFG binary

A. Similar to firmware upgrade, typing “mfgdl” on console.

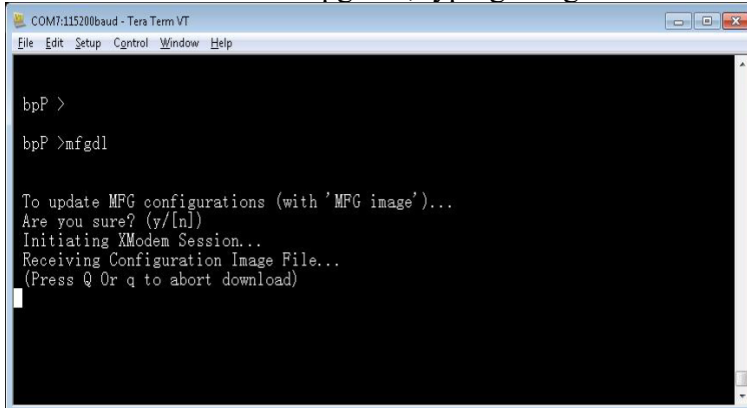

```

COM7:115200baud - Tera Term VT
File Edit Setup Control Window Help

bpP >
bpP >mfgdl

To update MFG configurations (with 'MFG image')...
Are you sure? (y/[n])
Initiating XModem Session...
Receiving Configuration Image File...
(Press Q Or q to abort download)
  
```

- B. Type “y” to commit MFG file upgrade.
- C. Select xmodem as the file transfer protocol.
- D. Select the correct MFG CFG file from file browser.
- E. Click “Open” to start file transfer.
- F. Serial console would then start file transfer.

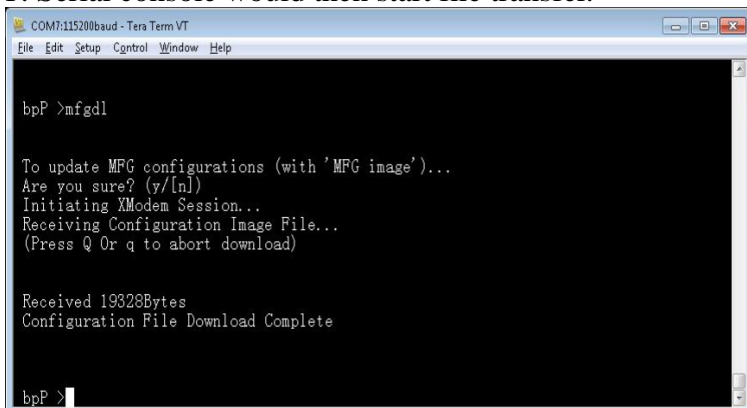

```

COM7:115200baud - Tera Term VT
File Edit Setup Control Window Help

bpP >mfgdl

To update MFG configurations (with 'MFG image')...
Are you sure? (y/[n])
Initiating XModem Session...
Receiving Configuration Image File...
(Press Q Or q to abort download)

Received 19328Bytes
Configuration File Download Complete

bpP >
  
```

G. Reset Expander to activate MFG CFG file by applying “reset” command or power recycle the system.

5.3.9.2 CLI (Telnet or SSH with Ethernet board)

When there is an Ethernet Management board on the system users should upgrade Ethernet Board firmware, SAS Expander firmware and MFG CFG file through network instead of xmodem when using CLI commands.

All sort of firmware upgrade goes through TFTP and the system would intelligently upgrade firmware to the right hardware. More conveniently, both the Primary and Secondary SAS Expanders would be upgraded at the same time when upgrade command is applied.

Run a TFTP server on your computer and assign the “Current Directory” with the path to where the firmware is stored. Assign “Server interface” with the IP address in the same domain as JBOD system. (Please be sure to configure TFTP server accordingly if you are using different TFTP server from the one in the example).

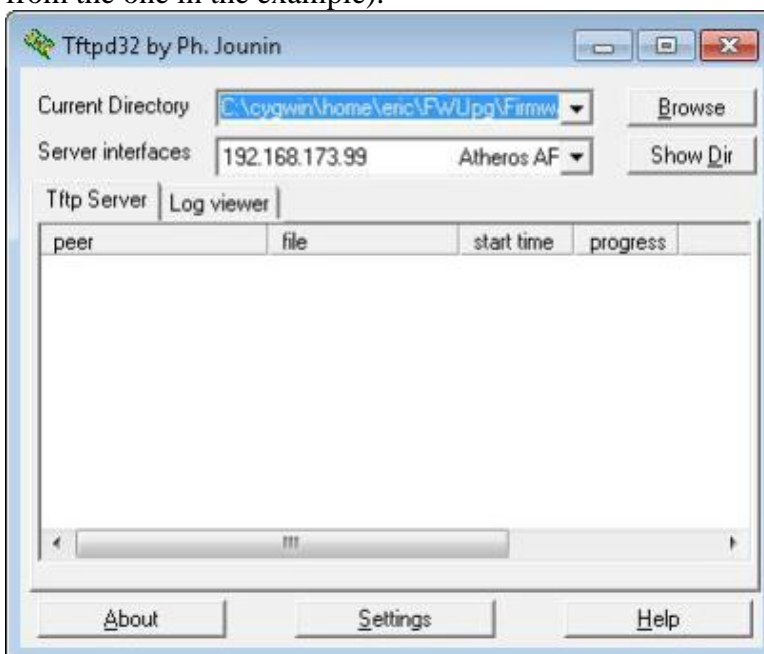

Do not turn off the system while the firmware is upgrading, it might crash the system.

New firmware does not take effect until a system reboot.

5.3.9.2.1 Ethernet Management Board Firmware

“upgrade <tftp_server_ip> <filename> command to start Ethernet Firmware upgrade.

```

COM8:115200baud - Tera Term VT
File Edit Setup Control Window Help
/management.s#
/management.s#
/management.s#
/management.s#
/management.s# upgrade
Usage: upgrade <ip_addr> <file_name>
/management.s#
/management.s#
/management.s#
/management.s# upgrade 192.168.173.99 RJ224-1.0.4.img
RJ224-1.0.4.img 100% |*****| 4174k 0:00:00 ETA
Erasing block: 1044/1044 (100%)
Writing kb: 4174/4174 (100%)
Verifying kb: 4174/4174 (100%)
Upgrade RJ224-1.0.4.img successfully
/management.s#

```

5.3.9.2.2 SAS Expander MFG CFG binary

Same as above by using the Expander MFG CFG binary filename in command.

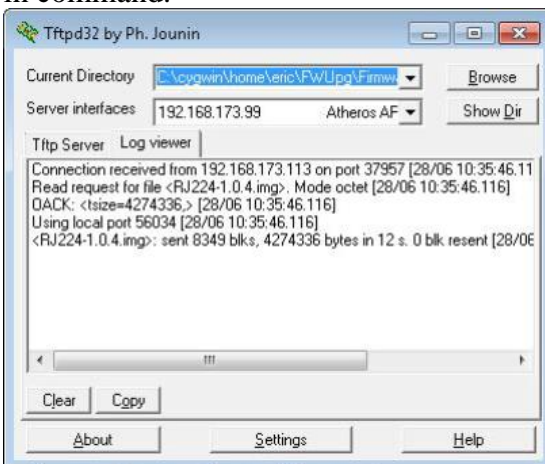

5.3.9.2.3 SAS Expander MFG CFG binary

Same as above by using the Expander MFG CFG binary filename in command.

```

COM8:115200baud - Tera Term VT
File Edit Setup Control Window Help
Hardware Version: A
Firmware Version: 00.0C.02.FF 06/06/2016 14:12
MFG CFG Version : 00.0A.00.FF 04/21/2016 15:44
SAS Address      : 5B0BD6D1A301177F
/management.s#
/management.s#
/management.s#
/management.s# upgrade
Usage: upgrade <ip_addr> <file_name>
/management.s#
/management.s#
/management.s#
/management.s# upgrade 192.168.173.99 msas3_H24R-3X_IJ224_vC_00xx_2016_0526.bin
msas3_H24R-3X_IJ224_vC_00xx_2016_0526.bin 100% |*****| 19524 0:00:00 ETA
Expander is upgrading: msas3_H24R-3X_IJ224_vC_00xx_2016_0526.bin
Done!
Upgrade msas3_H24R-3X_IJ224_vC_00xx_2016_0526.bin successfully
/management.s#

```

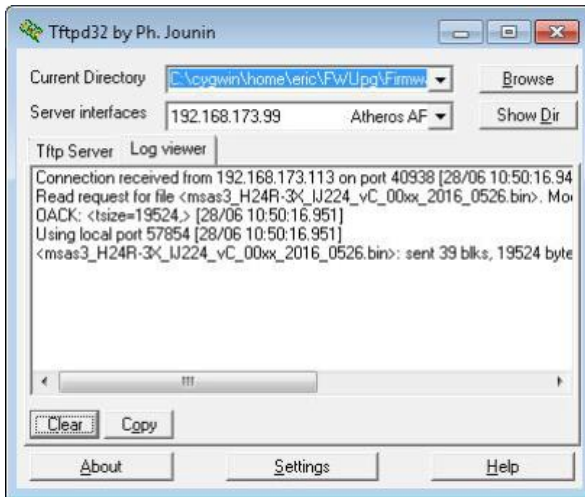

5.3.9.3 Web-GUI (with Ethernet board)

When there is an Ethernet Management board on the system users can upgrade system firmware through Web-GUI other than CLI in console or Telnet session.

Upgrade system firmware through Web-GUI is much easier than other ways. Just simply select the firmware by file browser and click 'Apply' to start.

All the firmware including Ethernet board firmware, SAS Expander firmware and MFG CFG file apply the same way to upgrade.

After system upgrade, be sure to reboot system to take effect the new firmware which has been upgraded to the hardware.

5.3.9.3.1 Open Web browser and give the URL filed with system IP address.

5.3.9.3.2 Given username and password on the Welcome page.

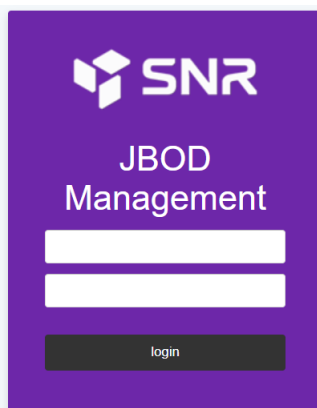

5.3.9.3.3 Click “Tool” button on the left pane and scroll down to “Software Upgrade” session on the right pane.

5.3.9.3.4 Click “Choose File” button to select the firmware being upgraded from file browser and click “Open” to commit.

The firmware can be an Ethernet board firmware, SAS Expander firmware or SAS Expander MFG CFG file. System intelligence would detect the firmware type and upgrade to the right hardware.

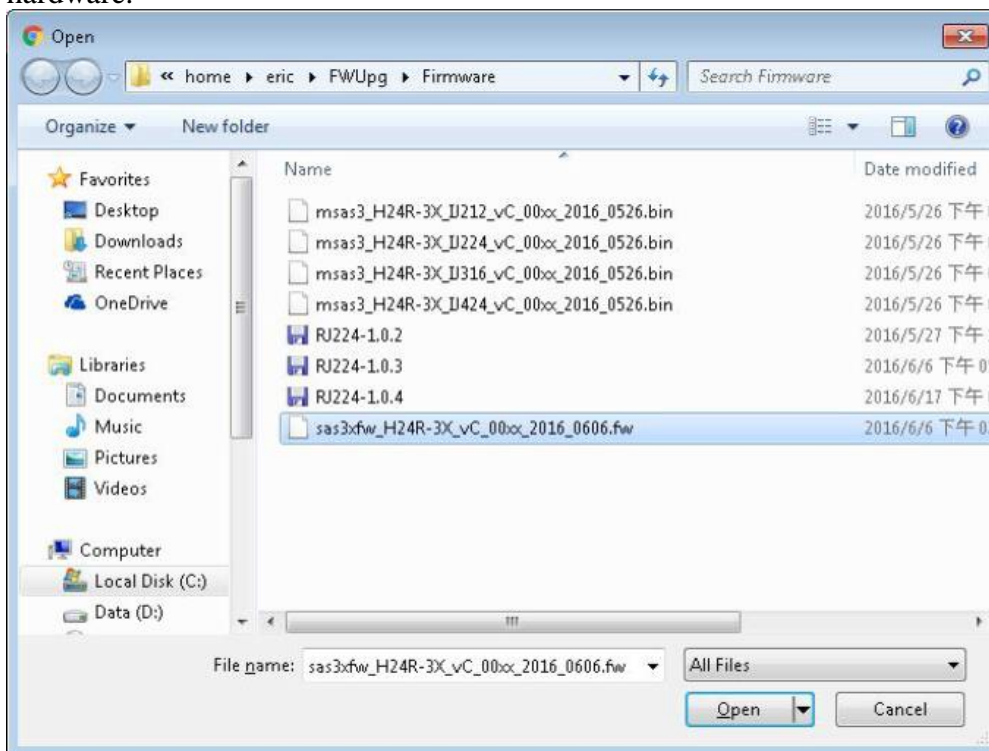

5.3.9.3.5 Click “Upgrade” button to start firmware upgrade.

5.3.9.3.6 Web would direct to a page telling firmware is upgrading.

After upgrade is done, Web will direct to the Login page.

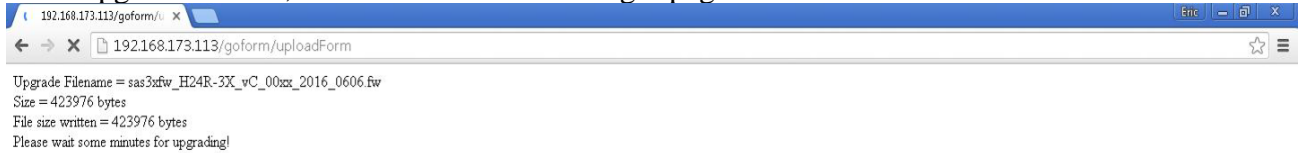

5.3.9.3.7 A system reboot is require to make new firmware take effect.

5.3.10 System Logs

JBOD systems support the capability to record system information to NVRAM for the purpose of activities history monitoring. The recorded information will retain until users issue clear command to erase from NVRAM or the NVRAM is full. Two categories of system information - Info and Fail would be recorded when happens.

5.3.10.1 CLI (UART without Ethernet Board)

Users can check the system logs by connecting serial cable to Expander RS-232 port directly. Users will need to physically connect serial cable to Primary or Secondary SAS Expander to check the logs on it.

Users can check the system logs by connecting serial cable to Expander RS-232 port directly. Users will need to physically connect serial cable to Primary or Secondary SAS Expander to check the logs on it.

5.3.10.1.1 “nvlogs” command to display all logs

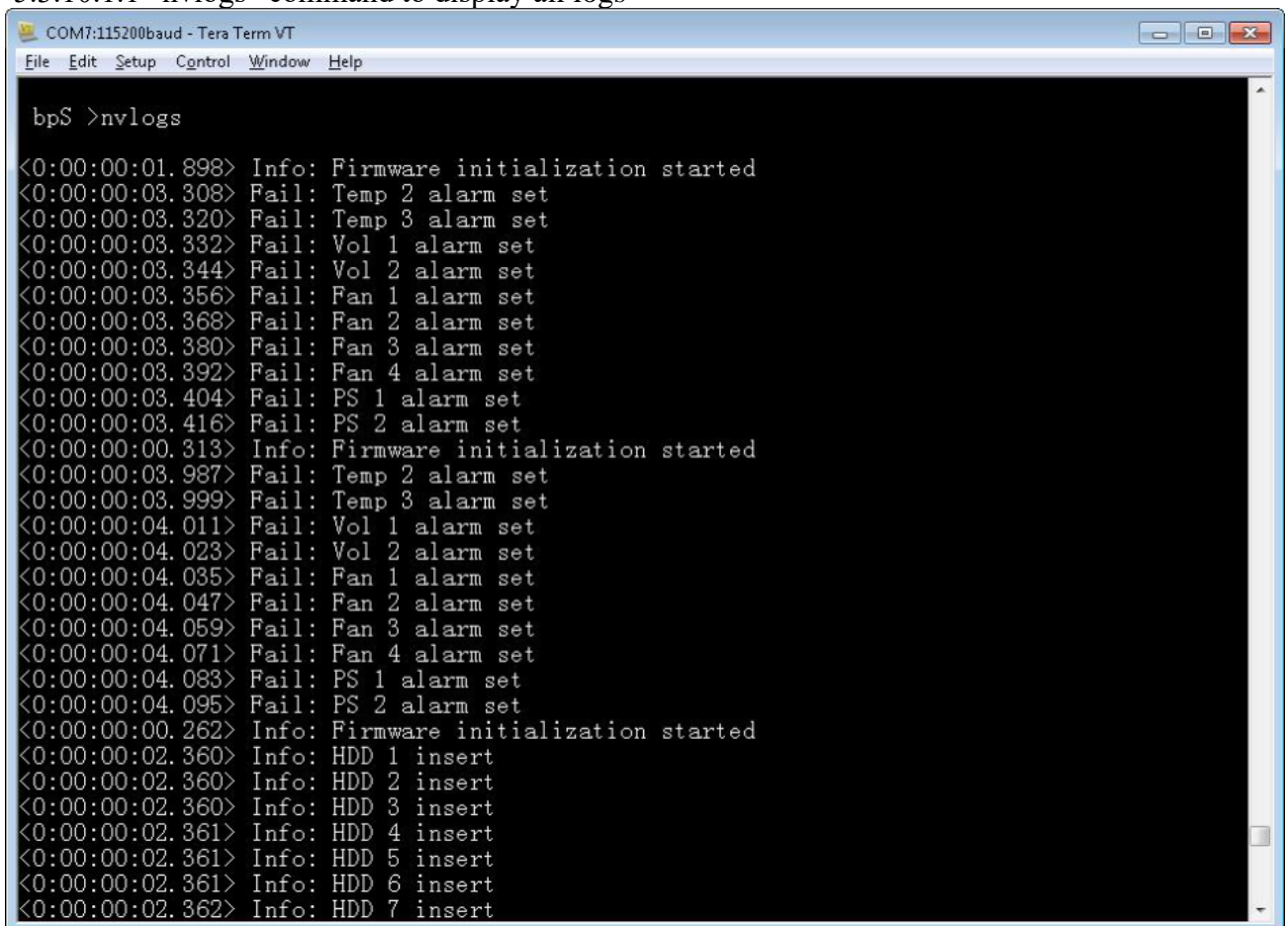

```

COM7:115200baud - Tera Term VT
File Edit Setup Control Window Help

bpS >nvlogs

<0:00:00:01.898> Info: Firmware initialization started
<0:00:00:03.308> Fail: Temp 2 alarm set
<0:00:00:03.320> Fail: Temp 3 alarm set
<0:00:00:03.332> Fail: Vol 1 alarm set
<0:00:00:03.344> Fail: Vol 2 alarm set
<0:00:00:03.356> Fail: Fan 1 alarm set
<0:00:00:03.368> Fail: Fan 2 alarm set
<0:00:00:03.380> Fail: Fan 3 alarm set
<0:00:00:03.392> Fail: Fan 4 alarm set
<0:00:00:03.404> Fail: PS 1 alarm set
<0:00:00:03.416> Fail: PS 2 alarm set
<0:00:00:00.313> Info: Firmware initialization started
<0:00:00:03.987> Fail: Temp 2 alarm set
<0:00:00:03.999> Fail: Temp 3 alarm set
<0:00:00:04.011> Fail: Vol 1 alarm set
<0:00:00:04.023> Fail: Vol 2 alarm set
<0:00:00:04.035> Fail: Fan 1 alarm set
<0:00:00:04.047> Fail: Fan 2 alarm set
<0:00:00:04.059> Fail: Fan 3 alarm set
<0:00:00:04.071> Fail: Fan 4 alarm set
<0:00:00:04.083> Fail: PS 1 alarm set
<0:00:00:04.095> Fail: PS 2 alarm set
<0:00:00:00.262> Info: Firmware initialization started
<0:00:00:02.360> Info: HDD 1 insert
<0:00:00:02.360> Info: HDD 2 insert
<0:00:00:02.360> Info: HDD 3 insert
<0:00:00:02.361> Info: HDD 4 insert
<0:00:00:02.361> Info: HDD 5 insert
<0:00:00:02.361> Info: HDD 6 insert
<0:00:00:02.362> Info: HDD 7 insert

```



5.3.10.1.2 “nvlogs info” to display only the information category logs.

```
COM7:115200baud - Tera Term VT
File Edit Setup Control Window Help

bpS >nvlogs info

<0:00:00:01.898> Info: Firmware initialization started
<0:00:00:00.313> Info: Firmware initialization started
<0:00:00:00.262> Info: Firmware initialization started
<0:00:00:02.360> Info: HDD 1 insert
<0:00:00:02.360> Info: HDD 2 insert
<0:00:00:02.360> Info: HDD 3 insert
<0:00:00:02.361> Info: HDD 4 insert
<0:00:00:02.361> Info: HDD 5 insert
<0:00:00:02.361> Info: HDD 6 insert
<0:00:00:02.362> Info: HDD 7 insert
<0:00:00:02.362> Info: HDD 8 insert
<0:00:00:02.362> Info: HDD 9 insert
<0:00:00:02.363> Info: HDD 10 insert
<0:00:00:02.363> Info: HDD 11 insert
<0:00:00:02.363> Info: HDD 12 insert
<0:00:00:02.364> Info: HDD 13 insert
<0:00:00:02.364> Info: HDD 14 insert
<0:00:00:02.364> Info: HDD 15 insert
<0:00:00:02.365> Info: HDD 16 insert
<0:00:07:20.207> Info: HDD 15 remove
<0:00:07:21.223> Info: HDD 15 insert
<0:00:00:00.262> Info: Firmware initialization started
<0:00:00:02.360> Info: HDD 1 insert
<0:00:00:02.360> Info: HDD 2 insert
<0:00:00:02.360> Info: HDD 3 insert
<0:00:00:02.361> Info: HDD 4 insert
<0:00:00:02.361> Info: HDD 5 insert
<0:00:00:02.361> Info: HDD 6 insert
<0:00:00:02.362> Info: HDD 7 insert
<0:00:00:02.362> Info: HDD 8 insert
```

5.3.10.1.3 “nvlogs fail” to display only the Fail category logs.

```
COM7:115200baud - Tera Term VT
File Edit Setup Control Window Help

bpS >nvlogs fail

<0:00:00:03.308> Fail: Temp 2 alarm set
<0:00:00:03.320> Fail: Temp 3 alarm set
<0:00:00:03.332> Fail: Vol 1 alarm set
<0:00:00:03.344> Fail: Vol 2 alarm set
<0:00:00:03.356> Fail: Fan 1 alarm set
<0:00:00:03.368> Fail: Fan 2 alarm set
<0:00:00:03.380> Fail: Fan 3 alarm set
<0:00:00:03.392> Fail: Fan 4 alarm set
<0:00:00:03.404> Fail: PS 1 alarm set
<0:00:00:03.416> Fail: PS 2 alarm set
<0:00:00:03.987> Fail: Temp 2 alarm set
<0:00:00:03.999> Fail: Temp 3 alarm set
<0:00:00:04.011> Fail: Vol 1 alarm set
<0:00:00:04.023> Fail: Vol 2 alarm set
<0:00:00:04.035> Fail: Fan 1 alarm set
<0:00:00:04.047> Fail: Fan 2 alarm set
<0:00:00:04.059> Fail: Fan 3 alarm set
<0:00:00:04.071> Fail: Fan 4 alarm set
<0:00:00:04.083> Fail: PS 1 alarm set
<0:00:00:04.095> Fail: PS 2 alarm set
<0:00:00:03.383> Fail: Fan 1 alarm set
<0:00:00:03.384> Fail: Fan 2 alarm set
<0:00:00:03.384> Fail: Fan 3 alarm set
<0:00:00:03.385> Fail: Fan 4 alarm set
<0:00:00:03.391> Fail: PS 1 alarm set
<0:00:00:03.397> Fail: PS 2 alarm set
<0:00:00:03.383> Fail: Fan 1 alarm set
<0:00:00:03.384> Fail: Fan 2 alarm set
<0:00:00:03.384> Fail: Fan 3 alarm set
<0:00:00:03.385> Fail: Fan 4 alarm set
```

5.3.10.1.4 “nvlogs clear” to erase all the logs from NVRAM.

```
COM7:115200baud - Tera Term VT
File Edit Setup Control Window Help

bpS >
bpS >nvlogs clear

Clear nvlogs ...

bpS >nvlogs

<Jun 24 2016 10:08:35.570> Info: Clear nvlogs

bpS >
bpS >
```

5.3.10.2 CLI (UART, Telnet, SSH with Ethernet Board)

Users can check the system logs by connecting UART cable to Expander RS-232 port directly, Telnet or SSH to the system and change directory to Primary or Secondary (if existed) SAS Expander layer.

- 5.3.10.2.1 “nvlogs” command to display all logs
- 5.3.10.2.2 “nvlogs info” to display information category logs.
- 5.3.10.2.3 “nvlogs fail” to display Fail category logs.
- 5.3.10.2.4 “nvlogs clear” to erase all the logs from NVRAM.

```

Telnet 192.168.173.112
RJ-212-03 login: admin
Password:
/mgmt.s#
/mgmt.s# cd primary
/mgmt.s/primary# nvlogs
nvlogs
<Jun 24 2016 08:38:06.491> Info: Clear nvlogs
<Jun 24 2016 00:38:23.000> Info: Set time
<Jun 23 2016 16:38:52.000> Info: Set time
<Jun 24 2016 00:37:32.000> Info: Set time
<Jun 24 2016 08:37:35.000> Info: Set time
<Jun 23 2016 23:37:00.000> Info: Set time
<Jun 24 2016 00:37:00.000> Info: Set time
<Jun 23 2016 23:38:00.000> Info: Set time
<Jun 24 2016 00:38:53.000> Info: Set time
<Jun 24 2016 00:41:04.100> Info: Firmware initialization started
<Jun 24 2016 00:41:04.200> Info: HDD 1 insert
<Jun 24 2016 00:41:04.201> Info: HDD 2 insert
<Jun 24 2016 00:41:04.201> Info: HDD 3 insert
<Jun 24 2016 00:41:04.202> Info: HDD 4 insert
<Jun 24 2016 00:41:04.202> Info: HDD 5 insert
<Jun 24 2016 00:41:04.202> Info: HDD 6 insert
<Jun 24 2016 00:41:04.203> Info: HDD 7 insert
<Jun 24 2016 00:41:04.203> Info: HDD 8 insert
<Jun 24 2016 00:41:04.203> Info: HDD 9 insert
<Jun 24 2016 00:41:04.204> Info: HDD 10 insert
<Jun 24 2016 00:41:04.204> Info: HDD 11 insert
<Jun 24 2016 00:41:04.204> Info: HDD 12 insert
<Jun 24 2016 00:41:19.000> Info: Set time
<Jun 24 2016 00:59:59.429> Info: MFG download
<Jun 24 2016 01:01:18.424> Info: FW download start
<Jun 24 2016 01:01:56.314> Info: FW download end
<Jun 24 2016 04:00:55.000> Info: Set time
<Jun 24 2016 05:03:45.143> Fail: Temp 2 alarm set
<Jun 24 2016 05:03:45.143> Fail: Temp 3 alarm set
<Jun 24 2016 05:04:52.380> Fail: Temp 1 alarm set
<Jun 24 2016 05:07:42.061> Fail: Temp 1 alarm clear

```

```

Telnet 192.168.173.112
/mgmt.s#
/mgmt.s# cd secondary/
/mgmt.s/secondary# nvlogs
nvlogs
<Jun 24 2016 10:08:35.570> Info: Clear nvlogs
<Jun 24 2016 10:10:03.000> Info: Set time
<Jun 24 2016 10:11:13.712> Fail: Fan 2 alarm set
<Jun 24 2016 10:11:13.713> Fail: Fan 4 alarm set
<Jun 24 2016 10:11:15.723> Fail: Fan 2 alarm clear
<Jun 24 2016 10:11:15.724> Fail: Fan 4 alarm clear
<Jun 24 2016 10:11:19.745> Fail: PS 2 alarm set
<Jun 24 2016 10:11:22.763> Fail: PS 2 alarm clear
<Jun 24 2016 10:35:47.000> Info: Set time
<Jun 27 2016 01:38:40.234> Info: Firmware initialization started
<Jun 27 2016 01:38:40.371> Info: HDD 1 insert
<Jun 27 2016 01:38:40.371> Info: HDD 2 insert
<Jun 27 2016 01:38:40.371> Info: HDD 3 insert
<Jun 27 2016 01:38:40.372> Info: HDD 4 insert
<Jun 27 2016 01:38:40.372> Info: HDD 5 insert
<Jun 27 2016 01:38:40.373> Info: HDD 6 insert
<Jun 27 2016 01:38:40.373> Info: HDD 7 insert
<Jun 27 2016 01:38:40.373> Info: HDD 8 insert
<Jun 27 2016 01:38:40.373> Info: HDD 9 insert
<Jun 27 2016 01:38:40.374> Info: HDD 10 insert
<Jun 27 2016 01:38:40.374> Info: HDD 11 insert
<Jun 27 2016 01:38:40.374> Info: HDD 12 insert
<Jun 27 2016 01:38:41.000> Info: Set time
/mgmt.s/secondary#
/mgmt.s/secondary#

```

5.3.10.3 Web-GUI (With Ethernet Board)

5.3.10.3.1 Type system IP address on Web Browser URL field to gain access to the system. After logging in, click “Log” button on the left pane to view and manage the Logs of the system.

5.3.10.3.2 The Log web page provides an easier way for managing the system logs including displaying different category of system logs and clearing the logs by clicking on the corresponding buttons.

5.3.10.3.3 Click “Refresh” and then “Process” button to display most current system logs.

5.3.10.3.4 Click “Warning Only” and then “Process” button to display the Warning category system logs.

5.3.10.3.5 Click “Info Only” and then “Process” button to display the Information category system logs.

5.3.10.3.6 Click “Clear” and then “Process” button to erase all the system logs.

6 Compatibility Lists

To reach the best performance and avoid system failure, strongly recommends users to choose the components from compatibility list. All the components are tested in In Win's lab, and assured the components are complementary with chassis.

You can download the latest updated device compatibility list from website:
<https://www.in-win.com/en/ipc-server>

7 Q&A

Section 1: Expander

1. What is the expander's function?

A: Expanded capacity, the expander can manage more SAS drives through a SAS cable in JBOD.

2. Why is the SNR-JB series storage server chassis built-in expander boards, and the SNR-JB series JBOD enclosures using expander modules?

A: SNR-JB chassis needs a motherboard to compose a system, the expander board can work seamlessly with the motherboard to manage the drives. Different from the chassis, the SNR-JB JBOD enclosure uses hot-swappable expander modules to satisfy the requirements of both capacity expansion and JBOD redundancy.

3. Why does the SNR-JB JBOD enclosure need 2 expander modules?

A: It is for redundancy. If the user does not need this function, a single expander module also works.

4. What are the functions of the three connector ports on the expander module?

A: SAS 0 is the connecting port to Server 0/RAID or HBA 0, SAS 1/RAID or HBA 1 is to Server 1, and EXP port is cascaded with another JBOD to expand the capacity.

5. Can I add more ports to the expander module?

A: First, please understand that these ports are used for cable connections. Second, only the Phy quantity of the expander chipset is allowed. Technically, this configuration can be worked out, yet technical alignment must be considered.

For example, an expander with a 3x36R chipset has totally 36 Phys, and each port consumes 4 Phys; thus, we can design a 9-port expander ($36/4 = 9$) to connect 9 cables. However, once we have used all the Phys for connecting, resulting in no remaining Phys to connect HDDs, and this design cannot achieve the original function.

6. Once I find that the expander is failing, what can I do?

A: SNR-JB series: Power off the system, and make sure the system is completely shut

down. Unplug the SAS cable to replace the expander board. series: Remove the faulty expander module, and replace a new expander module.

Section 2: Hard Disk

7. What is the difference between SAS and SATA disk, and how to choose?

A: SATA has only one throughput channel for data transmission, SAS has two. Once the system is designed with redundant functionality, SAS disk provides performance and reliability. SATA provides a cost selective option.

8. Are SAS and SATA disks compatible with SNR-JB series?

A: Yes, SNR-JB series support both SAS and SATA disks.

9. Can I mount 2.5" disks to 3.5" tool-less slots?

A: 3.5" tool-less slot does not support 2.5" disks at this moment. If this requirement is mandatory, please contact sales for OEM service.

10. Does the storage server or JBOD have to be fully populated to work?

A: No, you can mount partial bays and start the system. Once you need more storage space in the future, then add more disks.

11. Can I mount both SAS and SATA disks in an enclosure?

A: Yes, it works. However, you may need to consider about potential alignment issues.

12. If my system drive fails, can I replace the drive without shutting down the system?

A: By default, SNR-JB series' two internal disks don't support hot-swap feature. You can order an optional 2-bay hot-swap system disk module to reach your purpose.

Section 3: RAID/ Cascade

13. Is RAID card a required component for running a RAID system?

A: If your motherboard featured an onboard RAID function, or your OS supports software RAID, you do not need a RAID card. For technical details, please contact your motherboard or software vendor.

14. How many units can be cascaded to the SNR-JB series JBOD?

A: In maximum, a daisy chain can stripe 48 disks. (RJ212 max. 24 disks, RJ316 max. 32 disks, RJ424 max. 48 disks)

15. If I would like to cascade the JBOD, what components do I need?

A: You will need an SFF-8644 to SFF-8644 SAS cable, which meets the T10 standard. And the length we suggest is less than 3M to reach the best performance.

16. If I only have an internal RAID controller card, and I would like to expand the capacity,

how to add more disks?

A: SNR-JB series JBOD is designed for this purpose. If your RAID controller card does not have the external connecting port, you can use an SFF-8643 to SFF-8644 adaptor cable to connect the JBOD enclosure.

Section 4: Others

17. Why does the PSU have two modules? What are these two modules for?

A: Two PSU modules are used for redundancy. If you need this function, a PSU with two modules are required.

18. Can I add or reduce the quantity of fans?

A: The quantity of fans is related to the radiating efficiency. Usually, the quantity of fans depends on the system loading and the heat generation. Unless you have already tested, we strongly recommend not to change the default fans quantity.

19. Which parts support the hot-swap feature?

A: SNR-JB storage server: Fan, PSU and HDD.

SNR-JB JBOD enclosure: Fan, PSU, expander module and HDD.

20. Are 12Gb SAS ports compatible with 6Gb SAS or 6Gb SATA ports? What adapter can be converted?

A: 12Gb SAS does not align with 6Gb SAS, does not have an adapter to convert.

21. If the arm or handle is broken, how can I repair or replace it?

A: Please contact your local partner, or contact support for replacement and repair services.

22. If I would like to modify the GUI, how can I access it?

A: The copyright of the GUI is owned by. If you want to amend anything of the GUI, please contact sales for ODM services.

8 Technical Support

If you need help with installation or troubleshooting, you can contact your local partner, or send an e-mail to local contacts for technical assistance.