



**SNR-LS-G6**

**User manual**

## Table of contents

i

1	Security Statement .....	1
1.1	General safety precautions.....	1
1.2	Declaration of Toxic and Hazardous Substances .....	3
1.3	Warning Notice .....	5
1.4	Climate and environmental requirements.....	6
1.5	Other important descriptions.....	7
2	Product Introduction .....	8
2.1	System Introduction .....	8
2.2	Features .....	8
2.3	Product Technical Specifications.....	9
2.4	physical structure .....	9
2.5	Motherboard topology diagram.....	12
3	System components .....	13
3.1	Front panel components.....	13
3.2	Rear panel assembly .....	20
3.3	Motherboard components .....	28
3.4	Backplane assembly .....	30
3.5	Memory DIMM slots .....	35
3.6	Post- IO Storage configuration .....	40
3.7	Post- IO PCIe Configuration .....	40
3.8	PCIe Resource Allocation Rules .....	47
3.9	Hard drive configuration .....	49
3.10	Hard Drive Identification Number .....	54
3.11	Hard drive indicator light .....	55
3.12	System Fan .....	56

3.13	Power module .....	56
4	Operating system compatibility.....	57
4.1	operating system .....	57
5	Install system components.....	58
5.1	The chassis top cover is installed .....	47
5.2	Radiator Installation .....	60
5.3	Memory installation .....	61
5.4	Hard drive installation .....	62
5.5	M.2 Installation .....	63
5.6	IO 1 and IO 2 Module installation .....	65
5.7	IO 3 Module installation .....	66
5.8	Installation of OCP Network Card .....	67
5.9	Power Module Installation .....	67
5.10	Fan Module Installation .....	68
5.11	Air guide cover installation .....	69
5.12	RAID card battery pack installation .....	70
5.13	Guide rail assembly installation .....	70
6	Operating Precautions and Troubleshooting.....	75
6.1	Operational Precautions .....	75
6.2	Heat dissipation limitation description .....	77
6.3	Common Troubleshooting .....	80

# 1 Safety Instructions

## 1. General safety precautions

To prevent the risk of significant personal injury and property damage, please be sure to follow the following recommendations.

- Please do not open the system cover yourself. This operation should be performed by a professionally trained technician. The triangular marking with the lightning bolt symbol may contain high voltage or cause electric shock; do not touch it.
- Never insert any object into any opening in the system. Inserting an object could cause a short circuit in internal components, potentially leading to a fire or electric shock.
- Important: Before performing any repairs, Disconnect all cables. (There may be more than one cable )
- It is strictly forbidden to perform any live operations such as turning on the machine before the cover is closed.
- When you need to open the lid, please wait for the internal equipment to cool down before proceeding , otherwise you may get burned.
- Do not use this device in humid environments.
- If an extension cable is required... Please use a three-wire cable and ensure it is properly grounded.
- Ensure the server is properly grounded. This can be achieved through different grounding methods. However, it must be physically connected to the ground. If you are unsure whether you already have proper grounding protection, please contact us. Please contact the relevant organization or electrician for confirmation. Please use a three-core power cord and socket with grounding protection . Incorrect grounding may cause leakage, burning, explosion, or even personal injury.
- Please ensure that the power outlet and power interface make a tight connection. Loose contact may pose a fire hazard.
- Please use 220V Using equipment under AC voltage, or operating it under an inappropriate voltage, can lead to electric shock, fire, or even damage.
- The equipment must be well-ventilated and kept away from heat sources and fire sources. Do not block the cooling fan, otherwise the equipment may overheat and cause smoke, fire or other damage.
- Please keep the power cord and plug clean and intact, otherwise there may be a risk of electric shock or fire.
- Note: Improper battery replacement may cause an explosion hazard. Only use the same or equivalent replacement parts recommended by the manufacturer . Used batteries can pollute the environment. Please follow the instructions to set up the old battery after replacement.
- Keep computers away from electromagnetic fields.
- Stay away from electronic noise and interference caused by high-frequency equipment such as air conditioners, fans, motors, radio stations, television stations, and transmission towers .
- Do not plug or unplug internal components or mobile devices while the device is running, as this may cause the device to crash or be damaged.
- Please avoid frequent restarts or power cycles to extend the lifespan of the device.
- Please keep the environment clean and avoid dust. The operating temperature of the equipment is 5°C~35°C and the humidity is 8%~9

## 1.2 Declaration of Toxic and Hazardous Substances

Within the 10-year environmentally friendly service life, the toxic and harmful substances or elements contained in the product will not leak or mutate under normal use conditions, and the use of the equipment will not cause serious environmental pollution or serious personal injury or property damage to users.

Component Name	harmful substances					
	lead	merc ury	cadmi um	Hexaval ent chromiu m	Polybro minated biphenyl s	Polybromi nated diphenyl ethers
	(Pb)	( Hg )	(Cd)	(Cr VI)	(PBB)	(PBDE)
chassis /baffle	X	O	O	O	O	O
Mechanical components (fans, heat sinks, motors, etc.)	X	O	O	O	O	O
Printed circuit components - PCA*	X	O	O	O	O	O
cable /electric wire /connector	X	O	O	O	O	O
Hard Drive	X	O	O	O	O	O
Media Reading Storage devices (optical discs, etc.)	X	O	O	O	O	O
Power supply equipment /Power adapter	X	O	O	O	O	O
power supply	X	O	O	O	O	O
Point-of-use devices (such as mice)	X	O	O	O	O	O
keyboard	X	O	O	O	O	O
Full rack Guide rail products	X	X	O	O	O	O

○ This indicates that the content of the toxic and hazardous substance in all homogeneous materials of the component is below the limit requirements specified in GB/T26572-2011 "Limit Requirements for Restricted Substances in Electronic and Electrical Products".

× Indicates that the content of the toxic and hazardous substance in at least one homogeneous material of the component exceeds the limit requirements stipulated in GB/T26572-2011 "Limit Requirements for Restricted Substances in Electronic and Electrical Products". However, it complies with the EU RoHS directive (including its exemption provisions).

**illustrate**

lists the toxic and hazardous substances contained in all possible components of the equipment . Customers can refer to this table to check the toxic and hazardous substances contained in each component of the purchased product.

---

## 1.3 Warning Notice



warning:

Operating this device in a residential environment may cause radio interference.

Location restrictions: This device is not suitable for use in areas where children may be present.

Fan warning: Keep your body away from the fan blades when the fan is running .

## 1.4 Climate and environmental requirements

<b>temperature</b>	
Operating temperature	5°C The maximum temperature gradient is 10 °C per hour up to 35 °C.
Continuous operating temperature range (altitude below 950) Meters or 3117 (foot)	Under conditions where the equipment is not exposed to direct light, 5°C Up to 35°C.
Storage temperature range	-40°C Up to 75°C.
<b>humidity</b>	
Storage humidity	5% Up to 95% The air must never condense.
Operating humidity	8% Up to 90% The air must never condense.



### Notice

- If the equipment is used in an environment with inadequate or no lightning protection facilities. Please shut down the device and unplug the power cord, network cable, telephone line, etc. connected to it during thunderstorms.
  - Please use genuine operating systems and software, and configure them correctly.
  - Do not disassemble the server case or add or remove server hardware configurations yourself.
  - When equipment malfunctions, please first refer to the contents of this manual to identify and troubleshoot common problems. If you are unsure of the cause of the malfunction, please contact technical support for assistance.
  - Choosing a suitable environment for a computer helps it run stably and extends its lifespan.
-

## 1.5 Other important descriptions



If the equipment is marked with this logo, it means that the equipment with this logo is only designed and evaluated for safety at an altitude of 2000m. Therefore, it is only suitable for safe use below an altitude of 2000m. When used above an altitude of 2000m, there may be safety hazards.



If the equipment is marked with this mark, it means that the equipment with this mark is only designed and evaluated for safety in non-tropical climate conditions. Therefore, it is only suitable for safe use in non-tropical climate conditions. When used in tropical climate conditions, there may be safety hazards.

## 2 Product Introduction

### 2.1 System Introduction

SNR-LS-G6 is a high-end general-purpose server with a wide range of uses. It is based on Intel's new generation Xeon 6 processor platform and has been fully upgraded in terms of computing performance, storage capacity, and expansion capabilities. This product adopts a modular design, supports rich configurations and powerful expansion capabilities, can be flexibly configured according to business needs, and is widely used in diverse application scenarios such as virtualization, cloud computing, databases, and artificial intelligence.

### 2.2 Features

#### New platform Ultimate performance

- Support 2 Intel® Xeon® 6 processor, Single CPU Maximum 144 Core, with powerful computing performance;
- Supports 32 One DDR5 memory module, with a maximum frequency of 8000 MT /s, improves memory bandwidth. 42%;
- Fully supports PCIe 5.0, greatly improving system I/O. Throughput capacity Fully leverage the performance of the new platform.

#### Flexible configuration Super expansion

- The hardware module decoupling design enables flexible configuration of computing, storage, and networking to meet the needs of different scenarios ;
- Flexible selection of 3.5-inch, 2.5-inch, E3.S and other hard disk modules, supporting up to 24 U.2 NVMe and up to 32 E3.S NVMe;
- PCIe expansion and OCP network cards are flexible to configure, supporting up to 12 PCIe 5.0 standard slots and 2 OCP 3.0 network cards.

#### Stable and reliable Intelligent Management

- Key components of the system adopt redundant and hot-swappable designs, and peripheral components support tool-free quick disassembly and assembly, greatly shortening operation and maintenance time and improving system availability.
- Integrated BMC Intelligent management chip, Provides an open management platform. Supports IPMI 2.0, Redfish SNMP Various management agreements ;
- Provide health status monitoring and fault reporting functions for key components to achieve intelligent management services throughout the product life cyc

## 2.3 Product Technical Specifications

about for detailed technical specifications of the SNR-LS-G6

## 2.4 Physical structure

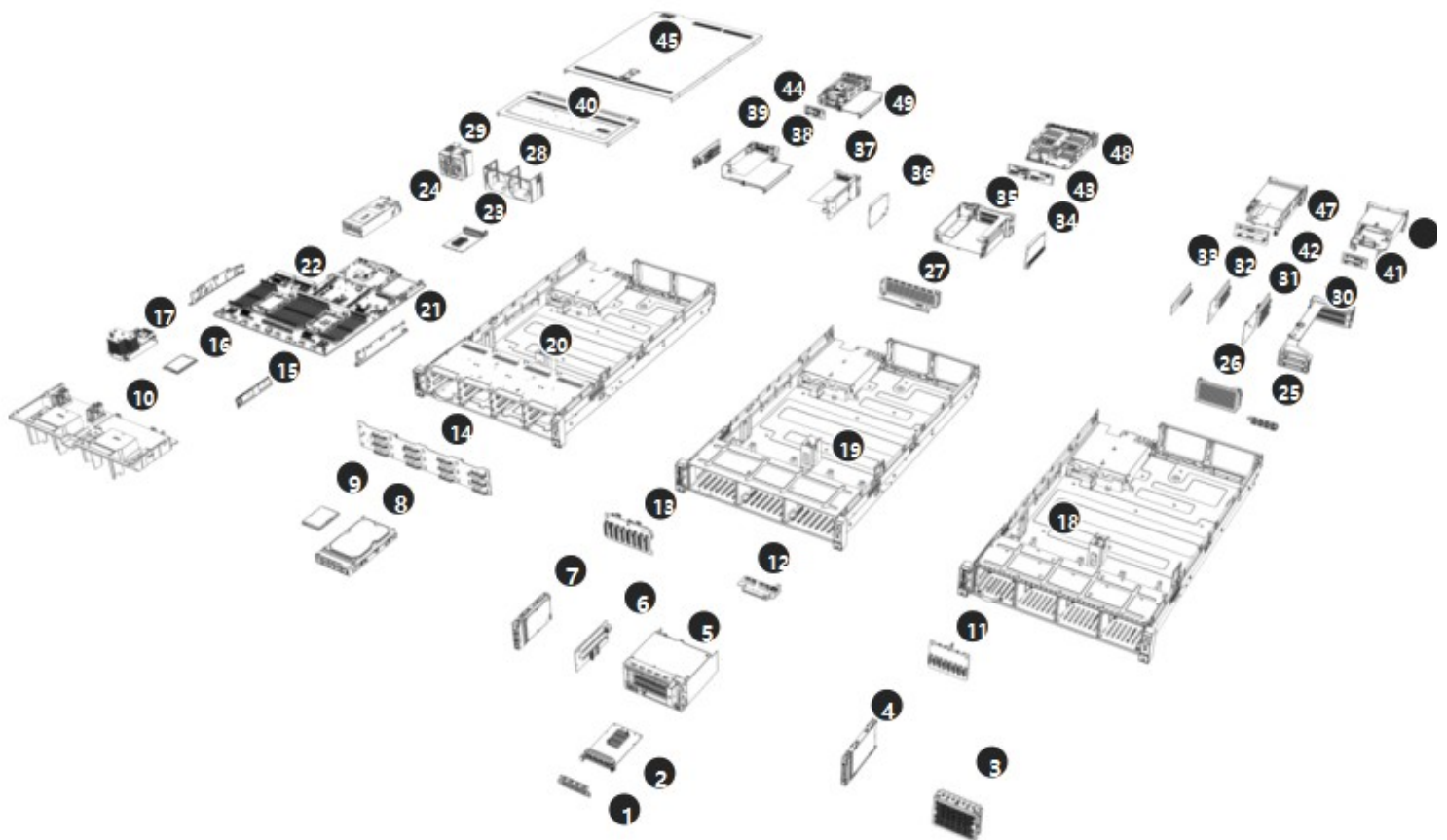

NO.	Module Name	NO.	Module Name
1	OCP network card cover	26	Post- IO 1/2 baffle
2	OCP network card	27	Post- IO 3 baffle
3	Fake hard drive panel	28	Fan frame
4	2.5 inch hard drive	29	fan
5	Dual-slot full-height PCIe and OCP Module	30	IO 1/2 Riser Card Module

6	Dual-slot full-height Riser Card	31	Three-slot full-height Riser card
7	E3.S 1T haddisk	32	Dual-slot full-height Riser Card
8	3.5 inch hard drive	33	Single-slot full-height Riser Card
9	2.5 inch hard drive	34	Dual-slot full-height Riser Card
10	Air guide cover	35	IO 3 Riser Module
11	2.5-inch hard drive backplate	36	Dual-slot half-height Riser Card
12	OCP Adapter board	37	IO 3 Riser Module
13	E3.S 1TB hard drive backplate	38	IO 3 Riser Module
14	3.5-inch hard drive backplate	39	Dual-slot half-height Riser Card
15	Memory	40	Front cover of the chassis
16	CPU	41	2 x 2.5-inch hard drive backplate
17	heat sink	42	2 x 2.5-inch hard drive backplate
18	All-flash hard drive chassis	43	IO 3 4 x 2.5-inch hard drive backplate
19	E3.S Hard drive case	44	IO 3 2 x 2.5 inch hard drive backplate
20	3.5-inch hard drive chassis	45	Rear top cover of the chassis
twenty one	Cable management rack	46	Hard drive expansion module
twenty two	motherboard	47	Hard drive expansion module
twenty three	OCP network card	48	Hard drive expansion module
twenty four	power supply	49	Hard drive expansion module
25	OCP network card cover		

## 2.5 Motherboard topology diagram

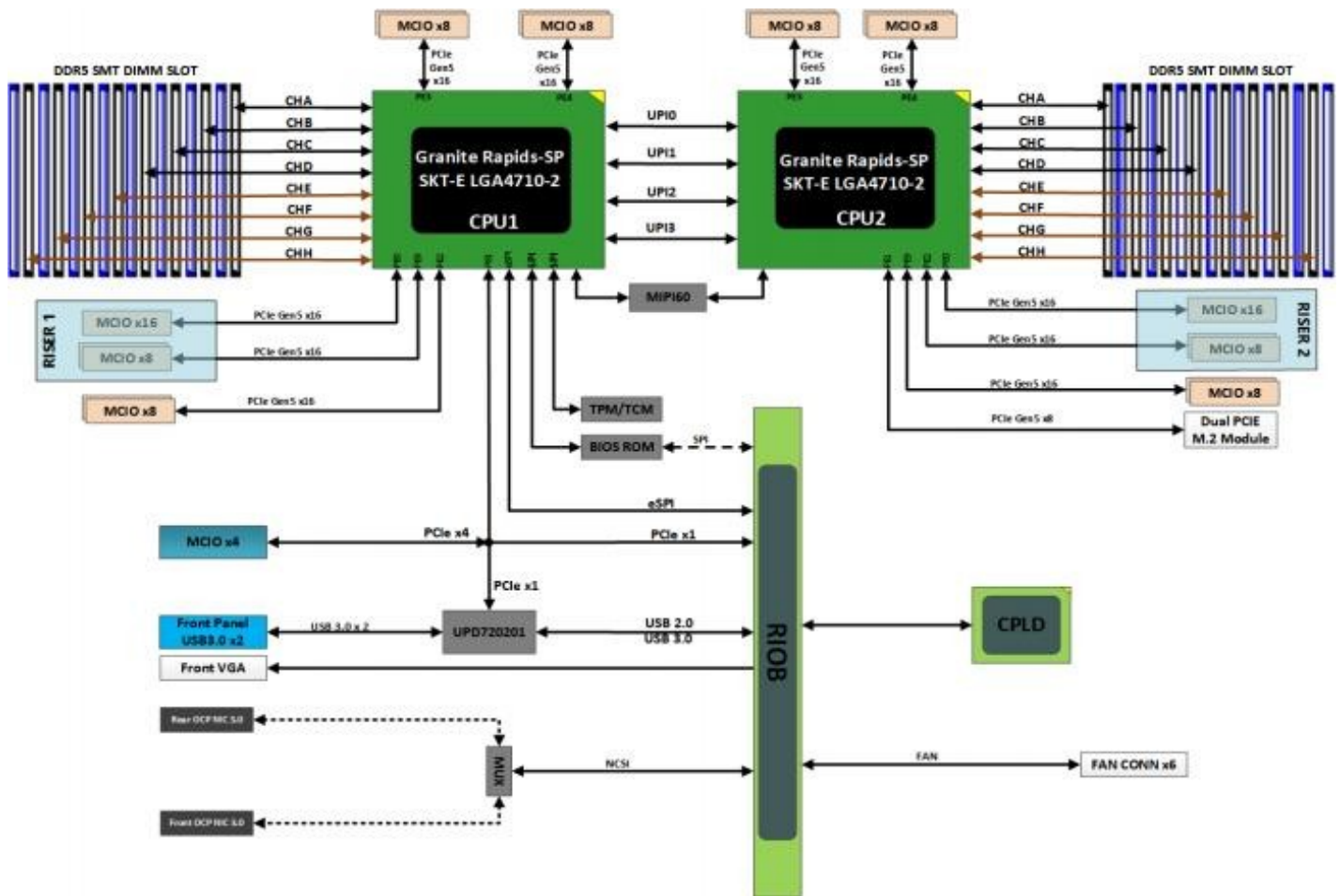

- SNR-LS-G6 supports 2 Intel BHS - SP Series processors, supporting 32 One DDR5 DIMM , processors communicate with each other via ... 4 UPI groups Bus interconnection, with a maximum transmission rate of 24 GT /s.
- Onboard M.2 interface: Provides 2 x4 M.2 interface ( CPU 2 PE 1 extension, supporting PCIe 5.0).
- Onboard MCIO interface: CPU 1 Provide 8 MCIO x 8 Interface and 1 MCIO x 16 interface CPU 2 provides 8 MCIO x 8 Interface and 1 MCIO x 16 interface It supports RISER extensions and U.2 NVMe via cable interconnect .
- PCIe Extended: Provide 2 PCIe Riser expansion slots, compatible with different PCIe... Riser offers different PCIe ... Extended combinations .
- Network extension: Provides a standard OCP NIC 3.0 expansion slot, supporting standard OCP NIC 3.0 SFF module.
- integrated AST 2600 management chip, Provides IPMI / KVM Management functions, providing VGA , management network port, Debug serial ports and other interf

### 3. System components

#### 3.1 Front panel components

- 2U16 2.5 sq m inch disk model

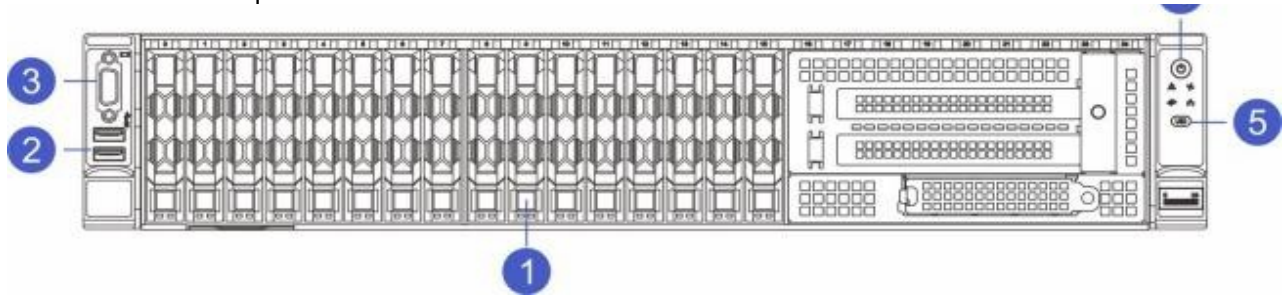

serial number	Module Name	serial number	Module Name
1	2.5 inch hard drive module	2	USB 3.0 interface
3	VGA interface	4	Power switch button
5	UID button		

- 2U16 bay E3.S 1TB drive model

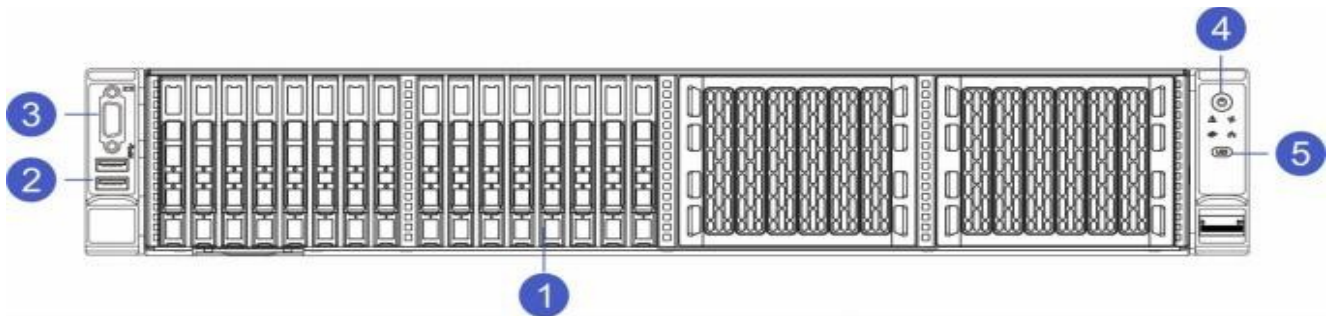

NO.	Module Name	NO.	Module Name
1	E3.S 1TB hard drive module	2	USB 3.0 interface
3	VGA interface	4	Power switch button

5	UID button		
---	------------	--	--

- 2U24 bay E3.S 1TB drive model

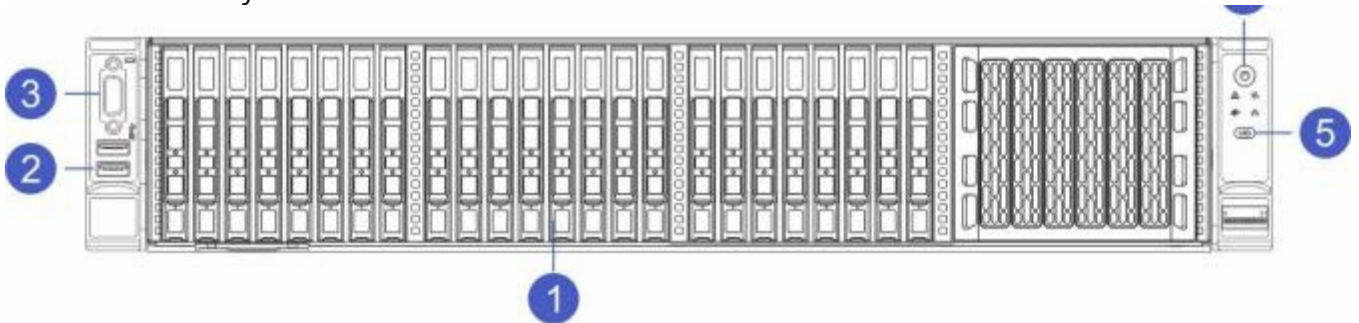

serial number	Module Name	serial number	Module Name
1	E3.S 1TB hard drive module	2	USB 3.0 interface
3	VGA interface	4	Power switch button
5	UID button		

- 2U32 bay E3.S 1TB drive model

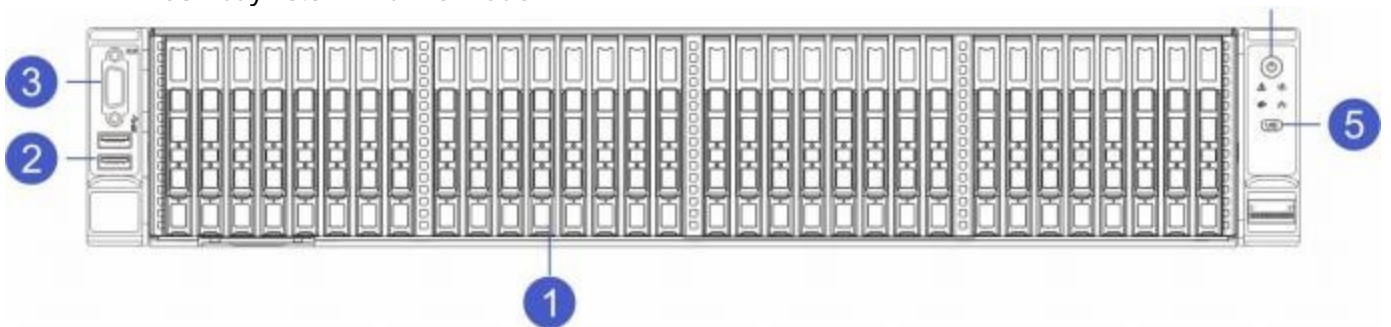

NO.	Module Name	NO.	Module Name
1	E3.S 1TB hard drive module	2	USB 3.0 interface
3	VGA interface	4	Power switch button

5	UID button		
---	------------	--	--

- 2U8 bays, 3.5 inches inch disk model

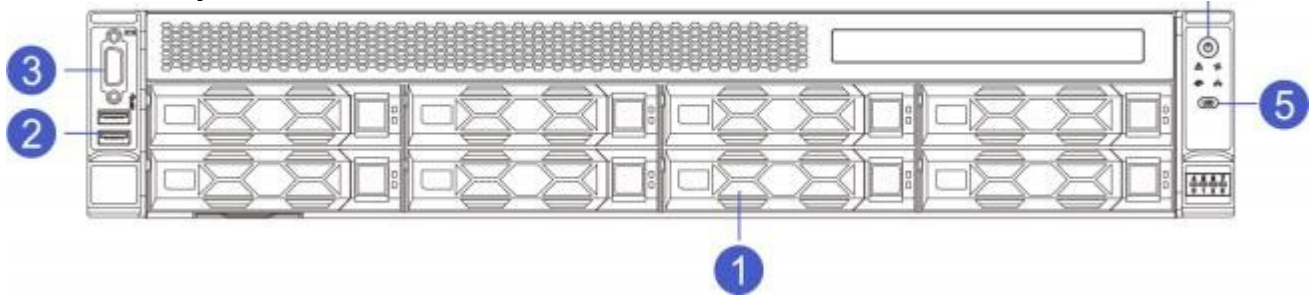

NO	Module Name	NO.	Module Name
1	3.5-inch hard drive module	2	USB 3.0 interface
3	VGA interface	4	Power switch button
5	UID button		

- 2U12 drive bays 3.5" inch disk model

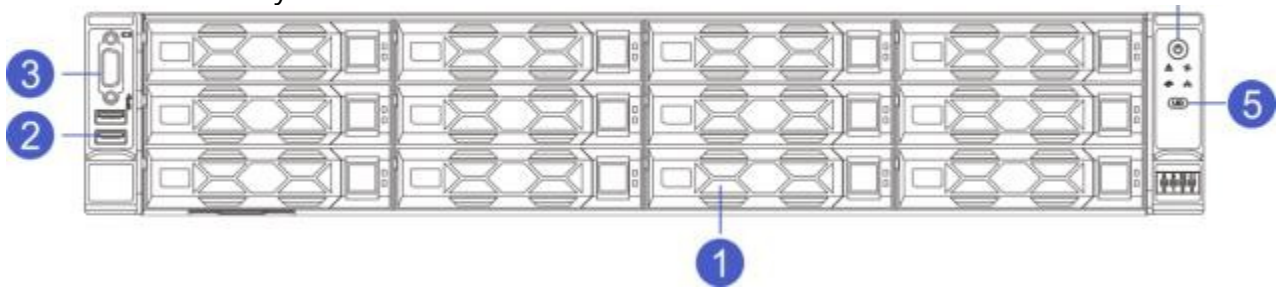

NO	Module Name	NO.	Module Name
1	3.5-inch hard drive module	2	USB 3.0 interface
3	VGA interface	4	Power switch button
5	UID button		

● 2U8 bays, 2.5" inch disk model

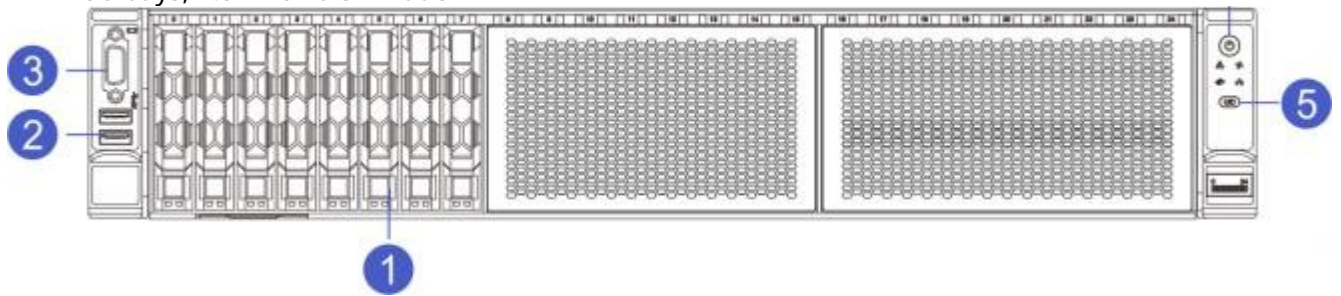

NO	Module Name	NO.	Module Name
1	2.5-inch hard drive module	2	USB 3.0 interface
3	VGA interface	4	Power switch button
5	UID button		

● 2U16 2.5 sq m inch disk model

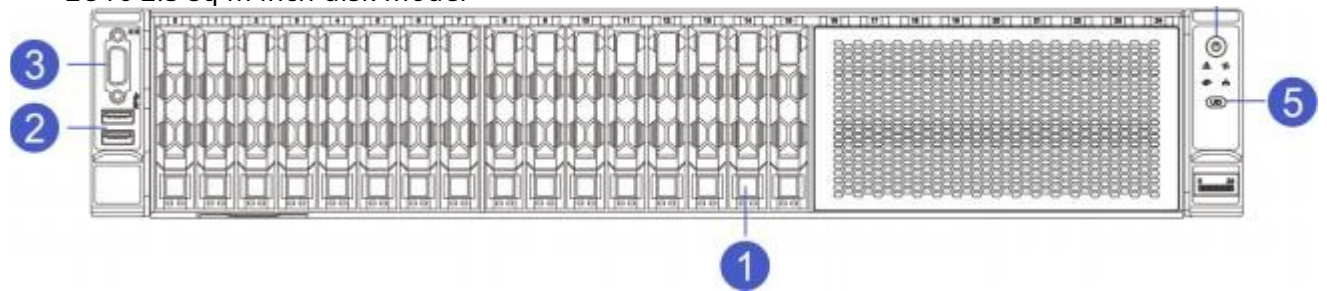

NO	Module Name	NO.	Module Name
1	2.5-inch hard drive module	2	USB 3.0 interface
3	VGA interface	4	Power switch button
5	UID button		

- 2U24 bays, 2.5" inch disk model

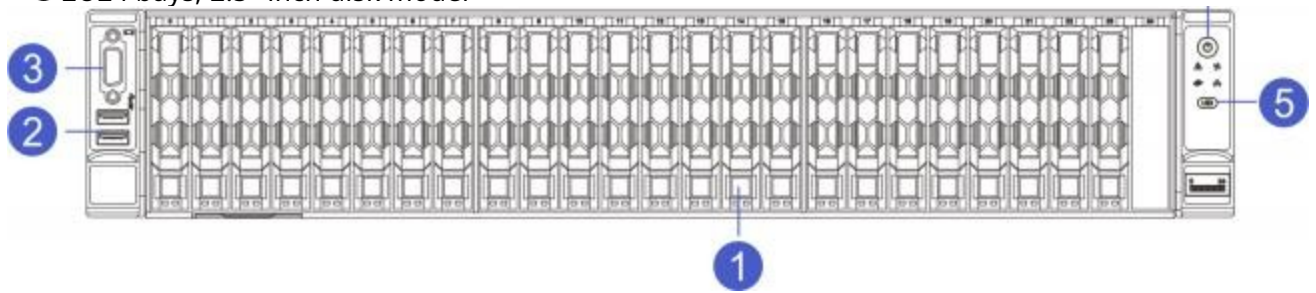

NO	Module Name	NO.	Module Name
1	2.5-inch hard drive module	2	USB 3.0 interface
3	VGA interface	4	Power switch button
5	UID button		



#### illustrate

The 3.5-inch hard drive bay can accommodate 3.5-inch and 2.5-inch hard drives.

- Front panel interface description

name	type	illustrate
VGA interface	DB 15	For connecting a monitor
USB interface	USB 3.0	Provides USB The interface allows USB devices to be connected.



#### Notice



When using an external USB device, please ensure that the USB device is in good working order; otherwise, it may cause the server to malfunction.

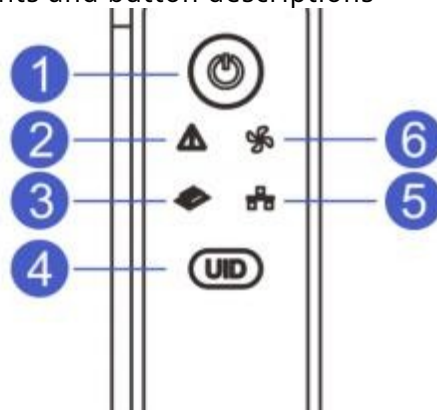



- Front panel indicator lights and button descriptions



NO.	Module Name	NO.	Module Name
1	Power switch button/indicator light	4	UID Buttons/Indicator Lights
2	System fault indicator	5	Network status indicator
3	Memory fault indicator light	6	Fan malfunction indicator light

- ✓ Short press this button while the device is powered on to power off the OS normally.

logo	Indicator lights/buttons	Status Description
	Power switch button/indicator light	<p>Power button instructions:</p> <ul style="list-style-type: none"> <li>✓ Press and hold this button for 6 seconds while the device is powered on. A few seconds can force the server to shut down.</li> <li>✓ When the device is powered on, briefly press this button. You can power it on. Power indicator light description:</li> <li>✓ Green (solid light ): Indicates that the device is powered on normally.</li> <li>✓ Green (flashing ): Indicates that the device is in standby mode.</li> <li>✓ Green off: indicates that the device is not powered on.</li> </ul>
	UID Buttons/Indicator Lights	<p>UID Buttons/indicator lights are used to easily locate the server to be operated, which can be done manually by pressing the UID. Buttons or BMC Command remote control to turn the light off or on.</p> <p>UID Button instructions:</p> <ul style="list-style-type: none"> <li>✓ Short press UID The button can be used to turn the positioning light on/off.</li> <li>✓ Long press UID Button 6 Second, It can reset the server BMC management system UID. Indicator light description:</li> <li>✓ Blue (solid/blinking )Indicates the server has been located.</li> </ul>

		<ul style="list-style-type: none"> <li>✓ "Off": This indicates that the server has not been located.</li> </ul>
	System fault indicator	<ul style="list-style-type: none"> <li>✓ Extinguished: Indicates that the equipment is operating normally.</li> <li>✓ A flashing red light indicates a device malfunction.</li> <li>✓ Solid red light: Indicates an alarm or malfunction in the device.</li> </ul>
	Fan malfunction indicator light	<ul style="list-style-type: none"> <li>✓ Off: Indicates the fan is working properly.</li> <li>✓ Solid red light: Indicates a fan malfunction.</li> </ul>
	Memory fault indicator light	<ul style="list-style-type: none"> <li>✓ Off: Indicates that the system memory is normal.</li> <li>✓ Solid red light indicates a system memory malfunction.</li> </ul>
	Network status indicator	<ul style="list-style-type: none"> <li>✓ Solid green: indicates that the network card connection is normal and there is no data communication.</li> <li>✓ Flashing green: indicates that the network card is connected normally and there is data communication.</li> <li>✓ Off: Indicates no network connection/no network module</li> </ul>

The network status indicator only shows the rear OC. P The network operating status of the network interface card (NIC) module .

### 3.2 Rear panel components

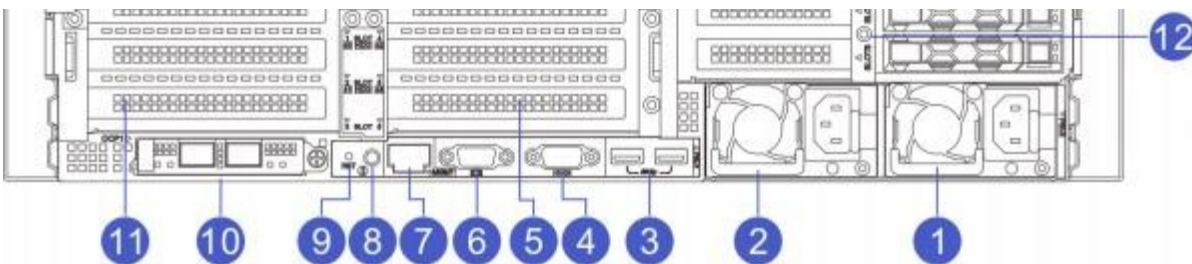
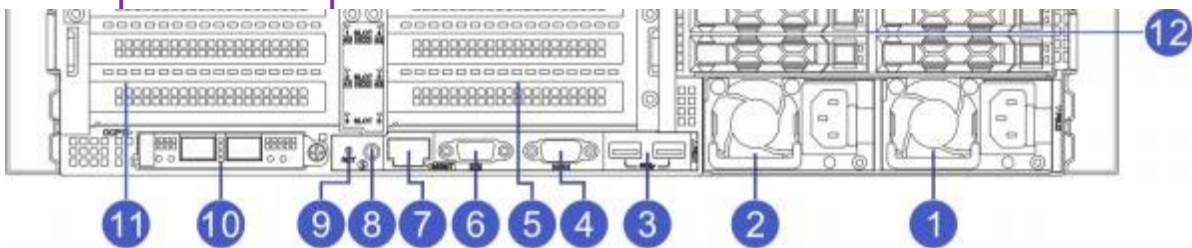

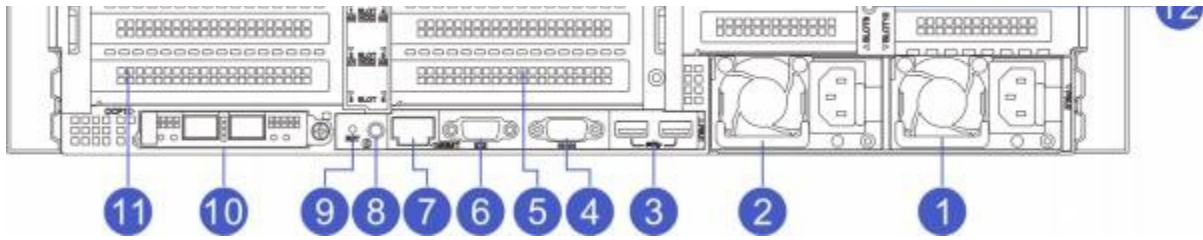

NO.	Module Name	NO.	Module Name
1	PSU2	7	IPMI management port
2	PSU1	8	UID Buttons and indicator lights
3	USB 3.0 interface	9	System reset button
4	COM interface	10	OCP 3.0 network card
5	IO Module 2	11	IO Module 1
6	VGA interface	12	IO Module 3

● Rear panel indicator lights and button descriptions

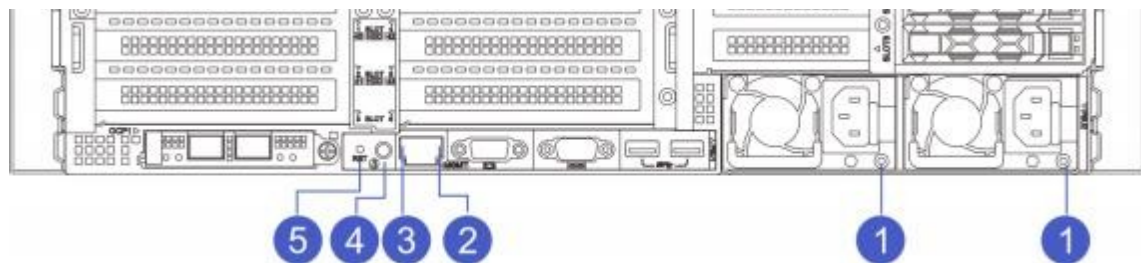
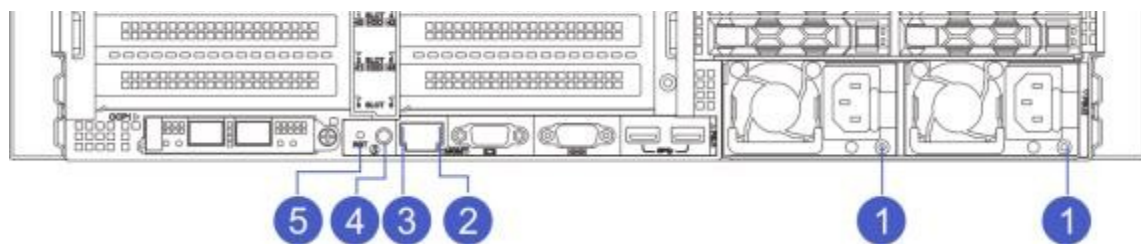

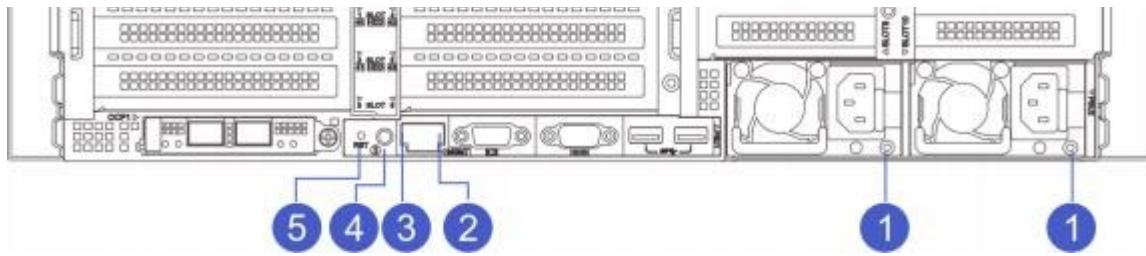

NO.	Module Name	NO.	Module Name
1	Power module indicator light	4	UID Buttons and indicator lights
2	Network activity status indicator	5	System reset button
3	Network connection status indicator		

Indicator lights/buttons	Status Description
Power module indicator light	<ul style="list-style-type: none"> <li>✓ Green (solid light ): Indicates normal input and output.</li> <li>✓ Off: Indicates no AC power input.</li> <li>✓ Green (flashing/1 Hz ) <ul style="list-style-type: none"> <li>● This indicates that the server is in standby mode. state;</li> <li>● This indicates that the power supply is in cold standby mode;</li> </ul> </li> <li>✓ Green (blinking/2 Hz )Indicates that the power supply is upgrading firmware.</li> <li>✓ Red (always on ) <ul style="list-style-type: none"> <li>● This indicates that the power supply has no output. Possible causes include power supply over-temperature protection, power supply output overcurrent/short circuit, output overvoltage, and component failure (not including all component failures).</li> <li>● This indicates that the power cord is not connected or has come loose;</li> </ul> </li> <li>✓ Red (flashing/1 Hz )Indicates that the power supply has an alarm signal, and the power module may be experiencing abnormalities such as high temperature , high load, high current, or low fan speed.</li> </ul>
UID Buttons and indicator lights	<ul style="list-style-type: none"> <li>✓ UID Indicator lights are used to easily locate the server to be operated, and can be manually accessed by pressing the UID. The light can be turned off or on remotely by pressing a button or using BMC commands.</li> <li>✓ Blue (solid/blinking )Indicates the server has been located.</li> <li>✓ "Off": This indicates that the server has not been located.</li> </ul>
Network connection status indicator	<ul style="list-style-type: none"> <li>✓ A solid green light indicates a gigabit link .</li> <li>✓ Solid orange light: Indicates 100Mbps Link .</li> <li>✓ Off: 10 Mbps Link / No network connection.</li> </ul>
Network activity status indicator	<ul style="list-style-type: none"> <li>✓ Yellow (flashing ): Indicates that data is being transmitted.</li> <li>✓ Extinguished: Indicates no data transmission.</li> </ul>
System reset button	<ul style="list-style-type: none"> <li>✓ It can be used to reset the system.</li> <li>✓ Short press: Reset system.</li> </ul>

● OCP NIC 3.0 Network card

The TU SNR-LS-G6 server supports standard OCP. NIC 3.0 SFF network interface cards, including the following four TTY self-developed models and other manufacturers' standard-compliant OCP network interface cards. NIC 3.0 network card.

- ◆ 4 Gigabit Ethernet NIC: T350 LO -E4

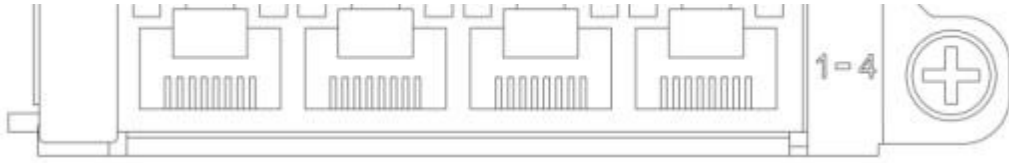

- ◆ Dual 10 Gigabit optical network interface card: T710 LO -F2



- ◆ 40 Gigabit Ethernet Adapter: T710 LO -F4

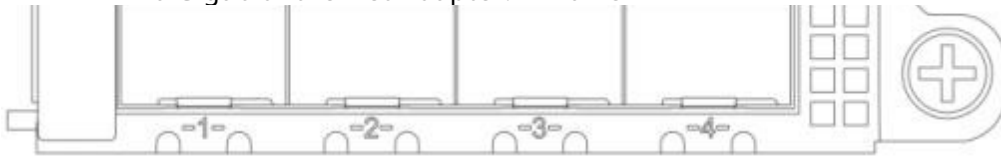

- ◆ Dual 25G optical port network cards: TCX4LO-S2



● OCP Network Card Indicator Light Description

For onboard network ports, standard network card ports, and snap-on network ports, the network indicator lights are designed as follows :

(1) Ethernet series network cards:

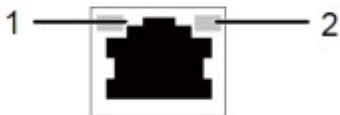

1: Rate status indicator (green/orange)	2: Data transmission indicator light (yellow)
---	---

Gigabit Ethernet Port:

ITEM	indicator lights	state
1	Rate status indicator	green Changliang: Current Link Link speed is 1G. orange Changliang: Current Link Link speed is 100M. lamp Extinguish: Current Link Link speed is 10M Or not connected.
2	Data transmission indicator light	yellow Flashing: Indicates data activity. yellow Extinguished: Indicates no data activity.

10 Gigabit Ethernet Port:

ITEM	indicator lights	state
1	Rate status indicator	green Changliang: Current Link Link speed is 10G. orange Changliang: Current Link Link speed is 1G. lamp Extinguish: Current Link Link speed is 100M Or not connected.
2	Data transmission indicator light	yellow Flashing: Indicates data activity. yellow Extinguished: Indicates no data activity.

(2) Optical port series network cards:

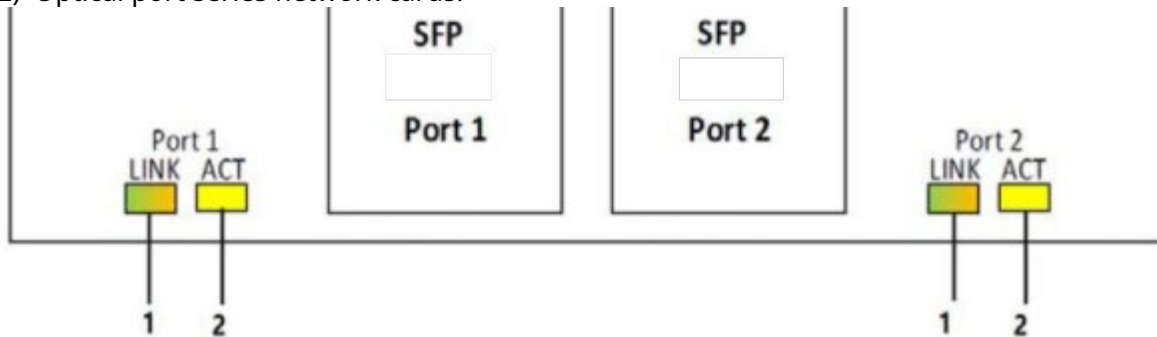

1: Rate status indicator (green/orange)	2: Data transmission indicator light (yellow)
---	---

SFP Module:

ITEM	indicator lights	state
1	Rate status indicator	green Changliang: Current Link Link speed is 10G. orange Changliang: Current Link Link speed is 1G. lamp Extinguish: Current Link Link speed is 100M Or not connected.
2	Data transmission indicator light	yellow Flashing: Indicates data activity. yellow Extinguished: Indicates no data activity.

SFP28 Module:

ITEM	indicator lights	state
1	Rate status indicator	green Always lit: Current Link The link speed is 25G. orange Always lit: Current Link The link speed is 10G. lamp Extinguish: Current Link Link speed is 1G Or not connected.
2	Data transmission indicator light	yellow Flashing: Indicates data activity. yellow Extinguished: Indicates no data activity.

### 3.3 Motherboard components

SNR-LS-G6 motherboard components, The interface description is as follows:

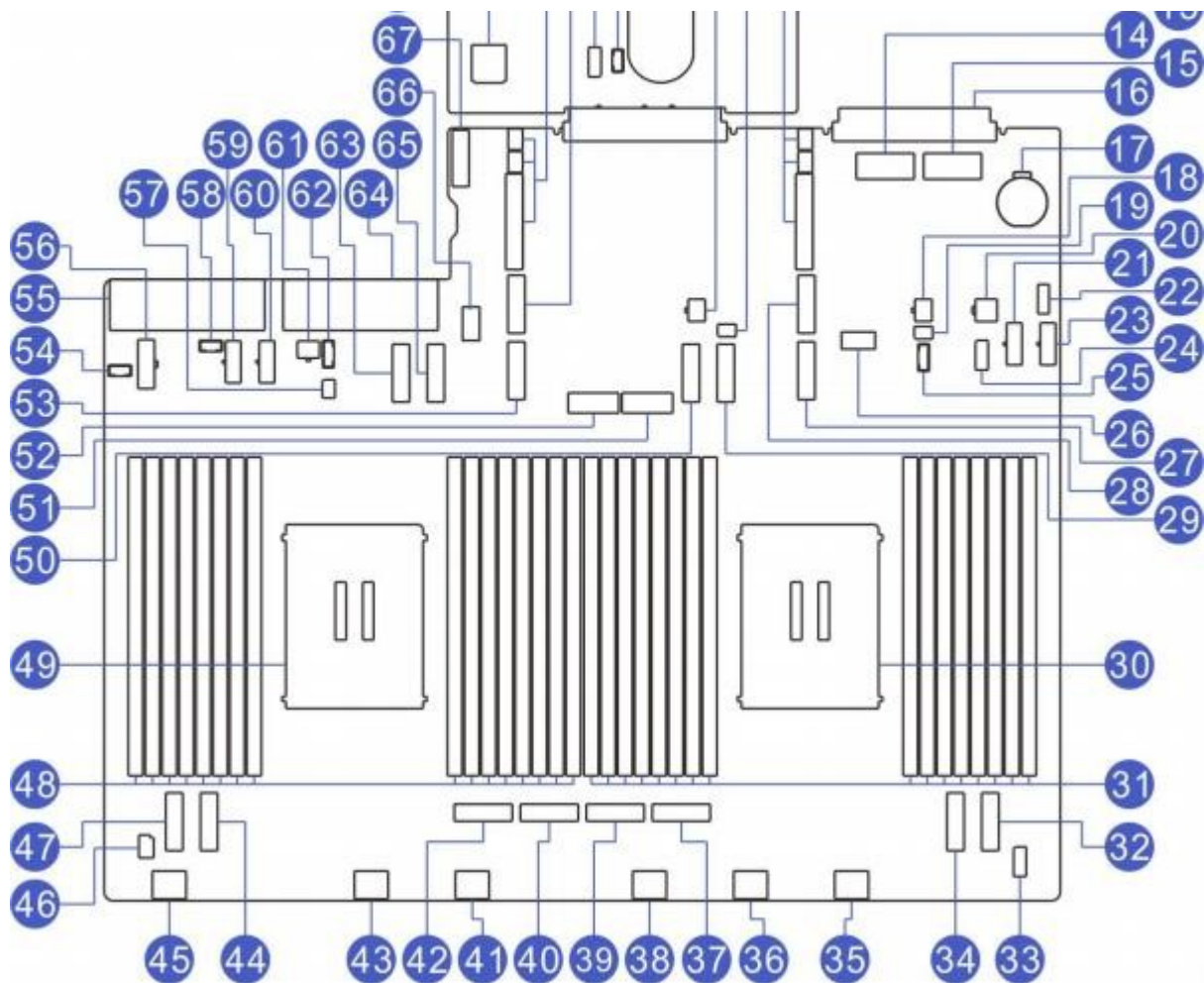

NO.	Module Name	NO.	Module Name
1	USB 3.0 PORT2	2	USB 3.0 PORT1
3	DPU NCSI interface	4	COM interface
5	Leakage detection interface	6	VGA interface
7	IPMI Management port	8	UID Button indicator
9	RST button	10	BMC SD slot
11	Rear hard drive power connector ( HDD) PWR 2)	12	Rear hard drive backplane signal connector (LED CONN 2)

13	Riser Card Slot 1 (corresponding to CPU 1)	14	OCP MCIO connector (OCP) MCIO0)
15	OCP MCIO Connector ( OCP) MCIO 1)	16	OCP NIC 3.0 Network Interface Card Connector
17	Battery socket	18	Rear hard drive power connector ( HDD) PWR 1)
19	Rear hard drive backplane Number even connector (LED CONN1)	20	Front-mounted OCP power connector 1 (FP OCP PWR)
twenty one	Front panel power connector (BP PWR3)	twenty two	TPM/TCM Interface (SPI TPM)
twenty three	Front panel power connector (BP PWR4)	twenty four	NCSI Connector (FP NCSI)
25	Out-of-band management connector ( SGPIO 1)	26	CPU 1 MCIO Connectors ( CPU 1 MCIO 8)
27	CPU 1 MCIO Connectors ( CPU 1 MCIO 1)	28	CPU 1 MCIO Connector ( CPU 1 MCIO 0)
29	CPU 1 MCIO Connectors ( CPU 1 MCIO 2)	30	CPU 1
31	Memory slot (corresponding to CPU1)	32	CPU 1 MCIO Connectors ( CPU 1 MCIO 4)
33	Front light panel signal connector (FP CONN)	34	CPU 1 MCIO Connectors ( CPU 1 MCIO 5)
35	Fan connector (FAN6)	36	Fan connector (FAN5)
37	CPU 1 MCIO Connectors ( CPU 1 MCIO 7)	38	Fan connector (FAN4)
39	CPU 1 MCIO Connectors ( CPU 1 MCIO 6)	40	CPU2 MCIO Connector (CPU2 MC IO4)
41	Fan connector (FAN3)	42	CPU2 MCIO Connector (CPU2 MCI O5)
43	Fan connector (FAN2)	44	CPU2 MCIO Connector (CPU2 MCIO7)
45	Fan connector ( FAN 1)	46	Intrusion switch interface ( INTRUDER) CONN )
47	CPU2 MCIO Connector (CPU2 MCI O6)	48	Memory slot (corresponding to CPU2)
49	CPU2	50	CPU 1 MCIO Connectors ( CPU 1 MCIO 3)
51	M.2 Slot (M.2 SLOT1)	52	M.2 slot (M.2 SLOT0)
53	CPU 2 MCIO Connectors ( CPU 2 MCIO 1)	54	Rear hard drive backplane I2C Connector (BP I2C 2)
55	PSU2 interface	56	GPU Power Connector (GPU PWR)
57	Rear hard drive backplane Number even connector (LED CONN 3)	58	Front hard drive backplane I2C Connector (BP I2C1)
59	Front panel power connector ( BP) PWR 1)	60	Front panel power connector (BP PWR2)
61	Rear hard drive power connector ( HDD) PWR 3)	62	Out-of-band management connector (SGPIO2)
63	CPU2 MCIO Connector (CPU2 MCI O3)	64	PSU2 interface
65	CPU2 MCIO Connector (CPU2 MCI O2)	66	Front VGA/USB Interface (FP VGA/USB)
67	Riser Card Slot 3	68	Front-panel DP/USB ports (FP DP/ USB)
69	Riser Card Slot 2 (corresponding to CPU2)	70	CPU2 MCIO Connector (CPU2 MCI O0)

### 3.4 Backplane assembly

Based on your system configuration, the supported driver backplanes are as follows:

system	Supported backplate options
SNR-LS-G6	4 x 3.5-inch SAS or SATA backplates
	8 x 2.5 1.5-inch SAS or SATA backplate
	8 x 2.5 inch SAS SATA NVMe backplane
	8 x 3.5 1.5-inch SAS or SATA backplate
	8 x 3.5 inch SAS SATA NVMe backplane
	12 x 3.5 1.5-inch SAS or SATA backplate
	8 x E3.S 1T backplate

4 x 3.5-inch SAS or SATA backplates

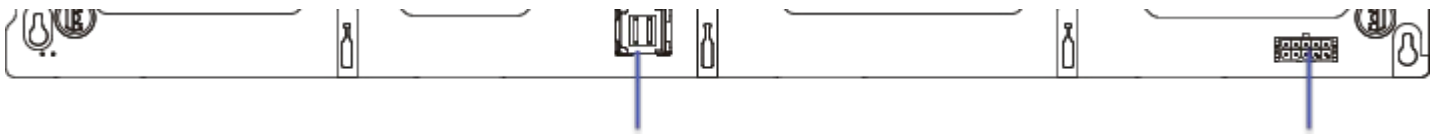

Serial Number	illustrate	silkscreen
1	x4 MINISAS HD interface	PORT0
2	Power interface	BP PWR

8 x 2.5 inch SAS SATA NVMe backplane

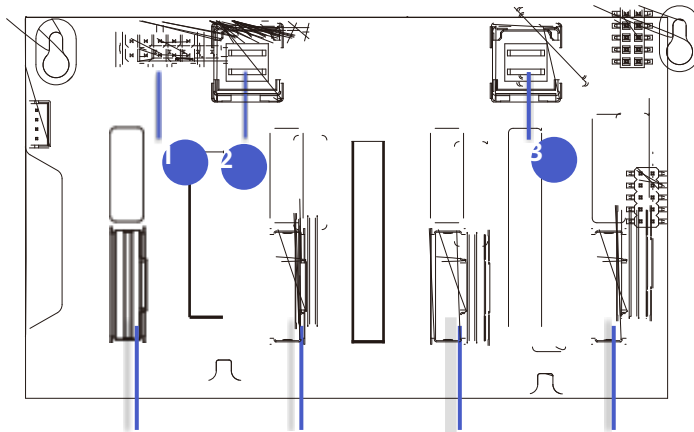

Serial Number	illustrate	silkscreen
1	Power interface	BP PWR
2	x4 MINISAS HD interface	PORT1
3	x4 MINISAS HD interface	PORT0
4	x8 SlimSAS interface	SLIM 3

5	x8 SlimSAS interface	SLIM 2
6	x8 SlimSAS interface	SLIM1
7	x8 SlimSAS interface	SLIM 0

8 x 3.5 inch SAS SATA NVMe backplane

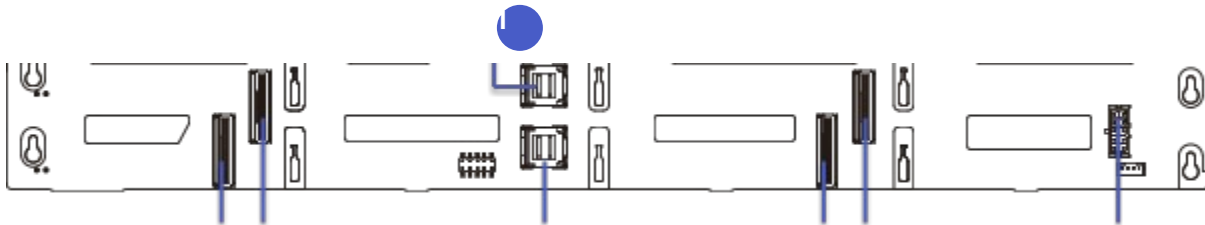

Serial Number	illustrate	silkscreen
1	x4 MINISAS HD interface	PORT1
2	x8 SlimSAS interface	SLIM1
3	x8 SlimSAS interface	SLIM 3
4	x4 MINISAS HD interface	PORT0
5	x8 SlimSAS interface	SLIM 0
6	x8 SlimSAS interface	SLIM 2
7	Power interface	BP PWR

8 x 3.5 1.5-inch SAS or SATA backplate

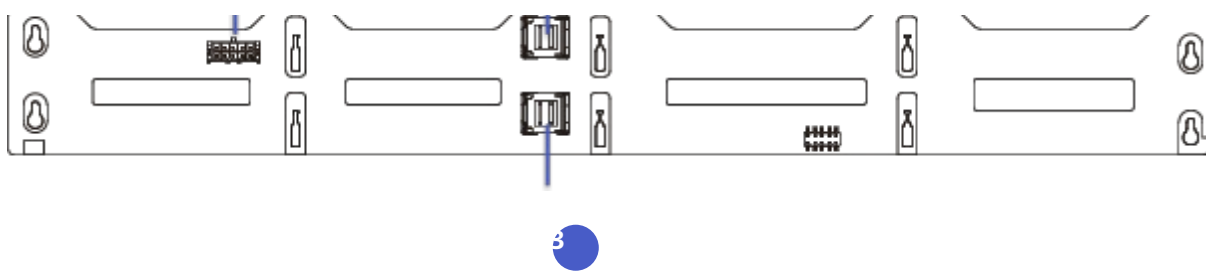

Serial Number	illustrate	silkscreen
1	Power interface	BP PWR
2	x4 MINISAS HD interface	PORT1
3	x4 MINISAS HD interface	PORT0

8 x E3.S 1T backplate

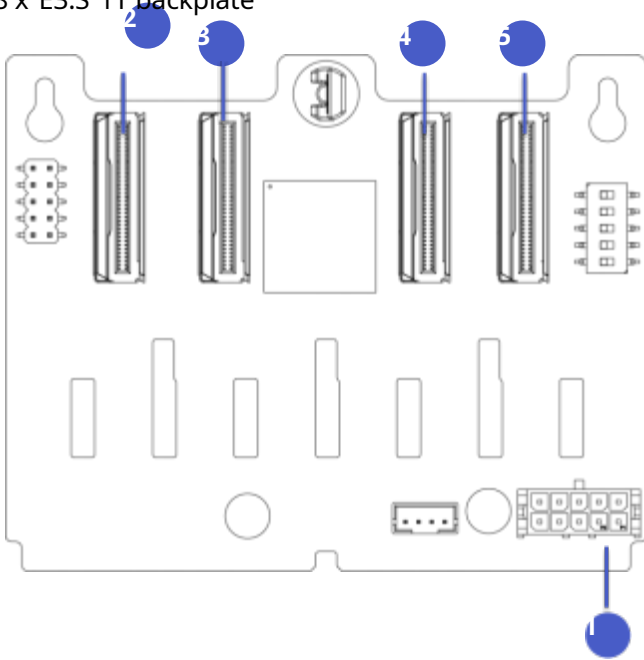

Serial Number	illustrate	silkscreen
1	Power interface	BP PWR
2	x8 MCI0 interface	MCI03
3	x8 MCI0 interface	MCI02
4	x8 MCI0 interface	MCI01
5	x8 MCI0 interface	MCI00

8 x 2.5 1.5-inch SAS or SATA backplate

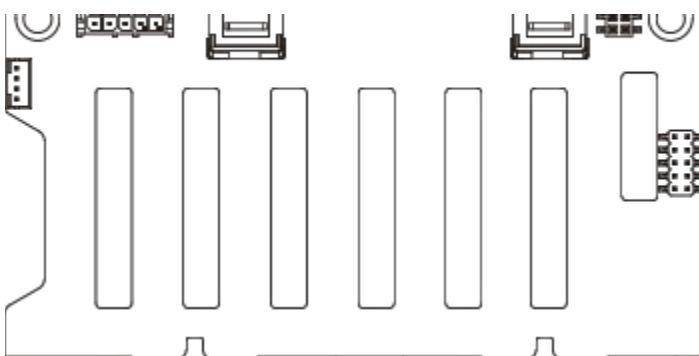

Serial Number	illustrate	silkscreen
1	Power interface	BP PWR

2	x4 MINISAS HD interface	PORT1
3	x4 MINISAS HD interface	PORT0

12 x 3.5 1.5-inch SAS or SATA backplate

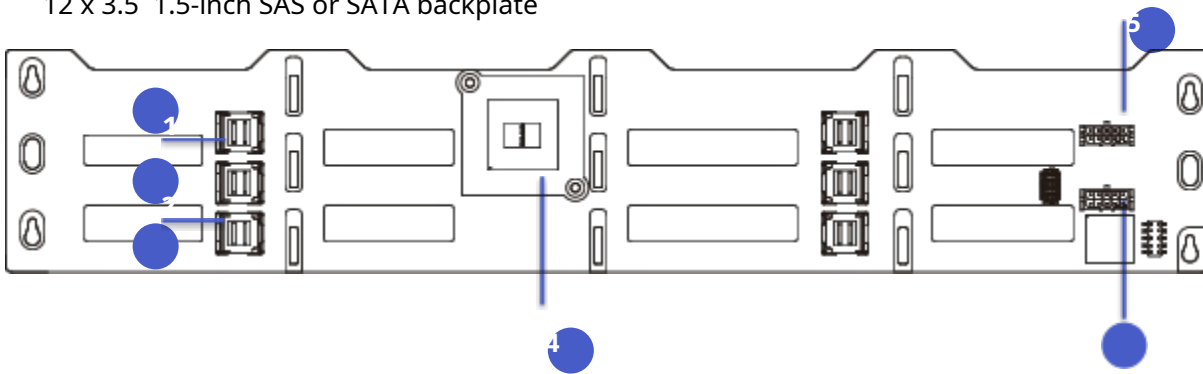

Serial Number	illustrate	silkscreen
1	x4 MINISAS HD interface	Rear PORT0
2	x4 MINISAS HD interface	SAS PORT1
3	x4 MINISAS HD interface	SAS PORT0
4	Expander chip	Expander chip
5	Power interface	BP PWR1
6	Power interface	BP PWR2

### 3.5 Memory DIMM slot

The server provides 32 DIMM Sockets, each CPU supports 16 The DDR5 memory modules, with their corresponding slots arranged as shown in the diagram below, are as follows:

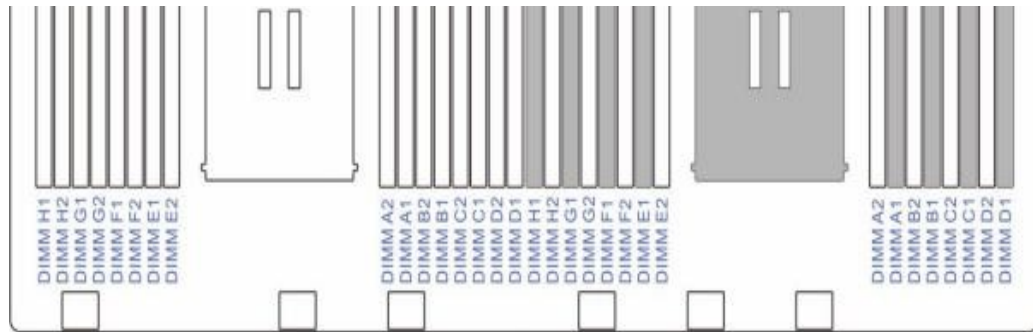

### Hint

- Each CPU Must install at least 1 Root memory,
- system installation DIMM in accordance with The number of CPUs is evenly distributed among each CPU. On the CPU.
- Different types ( RDIMM , ... ) are not allowed to be
- mixed on the same server. 3DS RDIMM ) and different specifications (capacity, bit width, Rank (etc.) memory.

Birch Each CPU on the Stream platform supports 8 channels of DDR5 memory. Memory speeds can reach 8000 MT /s, and each CPU supports 16

Root memory; Supported types include DDR 5 RDIMM (w/ ECC) 3DS - RDIMM , MCRDIMM ; DDR 5-

8000, 6400, 5200 MT /s

GNR - SP memory support is shown in the following figure:

Type	Ranks Per DIMM and Data Width	DRAM Density					Channel (DPC)	
		16Gb		24Gb		32Gb	1DPC/2SPC	2DPC/2SPC
		1DPC	2DPC	1DPC	2DPC	2DPC	1.1V	
RDIMM	1Rx8	16GB		24GB			6400, 6000, 5600, 5200, 4800 (DDR5-6400 rated RDIMMS only)	5200, 4800 (DDR5-6400 rated RDIMMS only)
	1Rx4	32GB		48GB				
	2Rx8	32GB	32GB	48GB				
	2Rx4	64GB	64GB*	96GB	96GB*	128GB*		
RDIMM 3DS	4Rx4		128GB*					
	8Rx4		256GB*					
MCRDIMM	2Rx8	32GB					8000, 7200 (MCR-8800 only)	N/A (no 2DPC configs for MCR)
	2Rx4	64GB						

\*Supported in IS/2S/4S/8S systems  
All others support IS/2S only

SRF - SP memory support is shown in the following figure:

Type	Ranks Per DIMM and Data Width	DRAM Density			Channel (DPC)	
		16Gb		32Gb	1DPC/2SPC	2DPC/2SPC
		1DPC	2DPC	1DPC	1.1V	
RDIMM	1Rx4	32GB			6400, 6000, 5600, 5200, 4800 (DDR5-6400 rated RDIMMS only)	N/A
	2Rx8	32GB				N/A
	2Rx4	64GB	64GB			5200, 4800 (DDR5-6400 rated RDIMMS only)
	2Rx4			128GB		N/A

CWF - SP memory support is shown in the following figure

	Data width	16Gb	24Gb		1DPC/2SPC	2DPC/2SPC
		1DPC	1DPC	2DPC	1.1V	
RDIMM	1Rx8	16GB	24GB		6400, 6000, 5600, 5200, 4800 (DDR5-6400 rated RDIMMS only)	5200, 4800 (DDR5-6400 rated RDIMMS only)
	1Rx4		48GB			
	2Rx8	32GB	48GB			
	2Rx4	64GB	96GB <sup>1</sup>	96GB <sup>1</sup>		
MCRDIMM	2Rx8	32GB	48GB		8000, 7200 (MCR-8800 only)	N/A (no 2DPC configs for MCR DIMM)
	2Rx4		96GB			

Specific memory support information can be found in the latest Snapshot file.

The motherboard's memory layout is similar to Birch. Stream CRB is consistent; channels A and E are located inside the CPU. Arrange them outwards in order. For example: Channel A

Closest to the CPU, channel B is close to channel A, channel C is close to channel B, and the outermost channel; Channels E/F/G/H are similar.

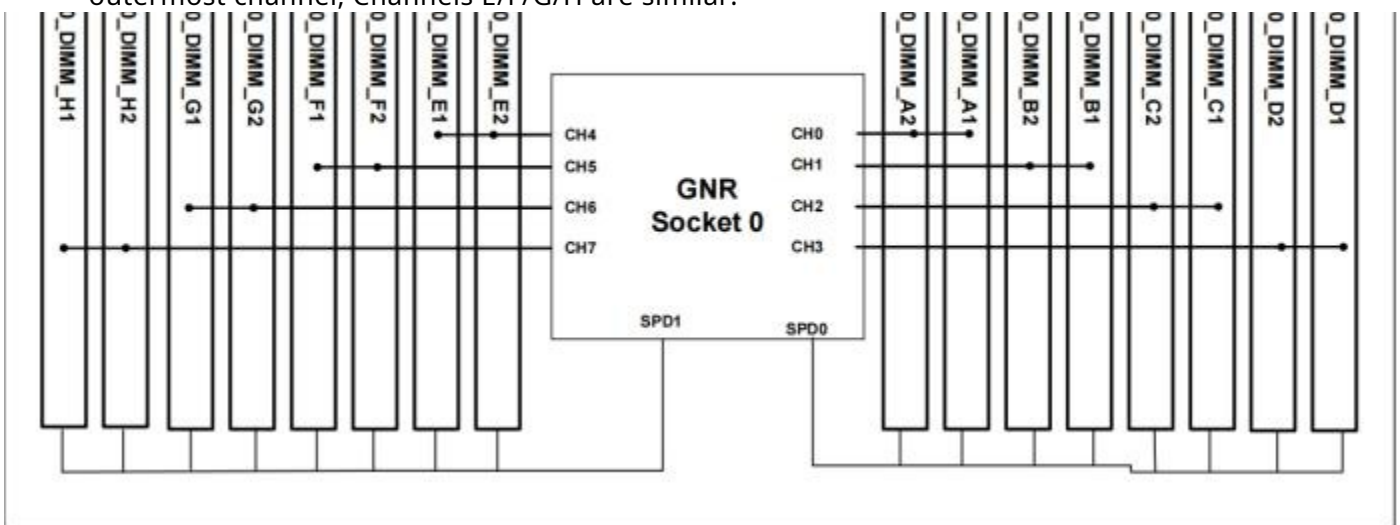

is DIMM 0 for the memory channel, which is usually the slot that must be used when using that channel. The black slots are...

DIMM 1 is used when two memory modules are installed in the same channel.

Birch Stream The platform supports mixed memory insertion under the following limitations:

1. RDIMM and MCRDIMM Do not mix and match
2. Memory modules on the same CPU channel must have the same Rank

3. x8 DIMMs of x4 cannot be on the same CPU. Inside or Mixed insertion on the same channel
4. Non -3 DS and 3DS DIMMs cannot be mixed.
5. 9x4 RDIMMs cannot be used with other categories.
6. same CPU All DIMMs on the socket must be at the same speed (DDR). DIMM When the frequency is inconsistent, it is controlled by the BIOS. Detective

The test was conducted, and the lowest frequency was used as the setting. (Intel has not verified this type of mixed plugging.)

7. When all memory slots on a single CPU are filled, only combinations of Rank 1 + Rank 2 are allowed; other Rank categories are not permitted to be mixed.

8. RDIMM /3 DS - RDIMM Supports mixed insertion from different manufacturers;

1. GNR - SP 's MCC / XCC single CPU supports single root, 2 pieces 4 pieces 6 pieces 8 pieces 12 pieces It requires 16 DDR5 RDIMM memory modules, with specific slot placement requirements. The table below lists the Intel ... Not being listed in the POR list does not mean that a POR cannot be used; however, please note:

- (1) Solutions may not be provided for combinations not listed in the inventory if there are any issues.

- (2) BIOS Must be enabled Enfore Population Por Function

- (3) The information listed in the table below may vary depending on the product cycle, Intel product, or validation results.

- (4) It is recommended that different channels of the CPU use memory of the same capacity; Combining different capacities may result in memory not being mapped or configured.

System usage (BIOS has no rules that can be checked).

- (5) GNR - SP POR Recommended connection diagrams are shown in the table below:

DDR5	Mode	CH7 (H)		CH6 (G)		CH5 (F)		CH4 (E)		C P U	CH0 (A)		CH1 (B)		CH2 (C)		CH3 (D)		SMC2 DDR5-64	Degraded A11	Degraded A11	HEM DDR5-64	Quad DDR5-64	Mirror			
		SLOT0	SLOT1	SLOT0	SLOT1	SLOT0	SLOT1	SLOT0	SLOT1		SLOT0	SLOT1	SLOT0	SLOT1	SLOT0	SLOT1	SLOT0	SLOT1								SLOT0	SLOT1
1	ILM																										P config
4				DDR5					DDR5	DDR5						DDR5				Y	Y	Y	Y				P config*
8		DDR5					DDR5					DDR5						DDR5		Y	Y	Y	Y				P config*
		DDR5			DDR5		DDR5		DDR5			DDR5				DDR5		DDR5		Y	Y	Y	Y				P config
12		DDR5	DDR5				DDR5	DDR5		DDR5	DDR5					DDR5	DDR5			Y	Y	Y	Y				F config
		DDR5		DDR5	DDR5	DDR5	DDR5		DDR5	DDR5	DDR5		DDR5	DDR5	DDR5	DDR5	DDR5			Y	Y	Y	Y				P config
16	DDR5	DDR5	DDR5	DDR5	DDR5	DDR5	DDR5	DDR5	DDR5	DDR5	DDR5	DDR5	DDR5	DDR5	DDR5	DDR5	DDR5	DDR5	Y	Y	Y	Y	Y	Y	Y	P config	

(6) SRF-SP POR Recommended connection diagrams are shown in the table below:

DDR5	Mode	CH7 (H)		CH6 (G)		CH5 (F)		CH4 (E)		C P U	CH0 (A)		CH1 (B)		CH2 (C)		CH3 (D)		SMC2	A11M11	Degraded A11	HEM	Interleav	SGE	Mirror		
		SLOT0	SLOT1	SLOT0	SLOT1	SLOT0	SLOT1	SLOT0	SLOT1		SLOT0	SLOT1	SLOT0	SLOT1	SLOT0	SLOT1	SLOT0	SLOT1									
1	ILM																										P config
4				DDR5					DDR5	DDR5						DDR5				Y			Y	Y	Y		F config
8		DDR5					DDR5					DDR5						DDR5		Y	Y	Y	Y				F config
		DDR5			DDR5		DDR5		DDR5			DDR5				DDR5		DDR5		Y	Y		Y	Y			F config
12		DDR5	DDR5				DDR5	DDR5		DDR5	DDR5					DDR5	DDR5			Y	Y	Y	Y				P config
		DDR5		DDR5	DDR5	DDR5	DDR5		DDR5	DDR5	DDR5		DDR5	DDR5	DDR5	DDR5	DDR5			Y	Y	Y	Y				P config
16	DDR5	DDR5	DDR5	DDR5	DDR5	DDR5	DDR5	DDR5	DDR5	DDR5	DDR5	DDR5	DDR5	DDR5	DDR5	DDR5	DDR5	DDR5	Y	Y	Y	Y	Y	Y	Y	P config	

(7) CWF - SP POR Recommended connection diagrams are shown in the table below:

DDR5	Mode	CH7 (H)		CH6 (G)		CH5 (F)		CH4 (E)		C P U	CH0 (A)		CH1 (B)		CH2 (C)		CH3 (D)		SMC3	Degraded A11	QUAD	Mirror					
		SLOT0	SLOT1	SLOT0	SLOT1	SLOT0	SLOT1	SLOT0	SLOT1		SLOT0	SLOT1	SLOT0	SLOT1	SLOT0	SLOT1	SLOT0	SLOT1									
1	ILM																										P config
4				DDR5					DDR5	DDR5						DDR5				Y	Y		Y				F config
8		DDR5					DDR5					DDR5						DDR5		Y	Y	Y	Y				F config
		DDR5			DDR5		DDR5		DDR5			DDR5				DDR5		DDR5		Y	Y		Y	Y			F config
12		DDR5	DDR5				DDR5	DDR5		DDR5	DDR5					DDR5	DDR5			Y	Y	Y	Y				P config
		DDR5		DDR5	DDR5	DDR5	DDR5		DDR5	DDR5	DDR5		DDR5	DDR5	DDR5	DDR5	DDR5			Y	Y	Y	Y				P config
16	DDR5	DDR5	DDR5	DDR5	DDR5	DDR5	DDR5	DDR5	DDR5	DDR5	DDR5	DDR5	DDR5	DDR5	DDR5	DDR5	DDR5	DDR5	Y	Y	Y	Y	Y	Y	Y	P config	

### 3.6 Back IO Storage configuration

- Rear 2x2.5" configuration

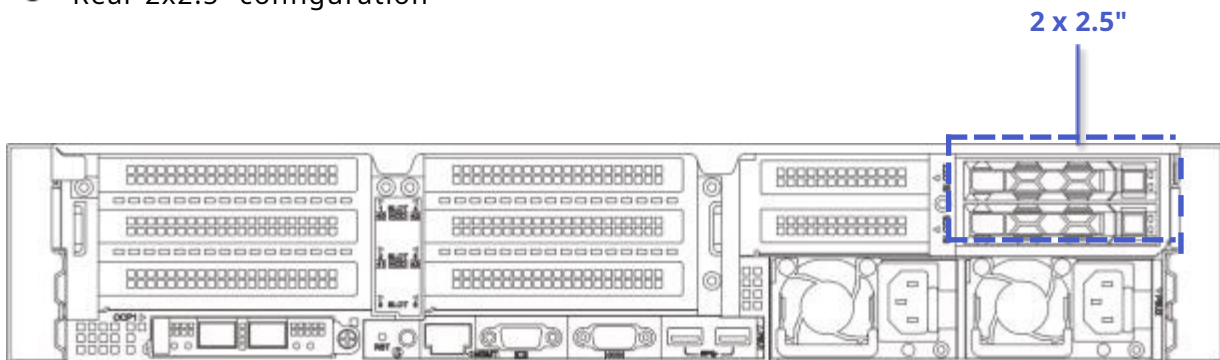

- Rear 4x2.5" configuration

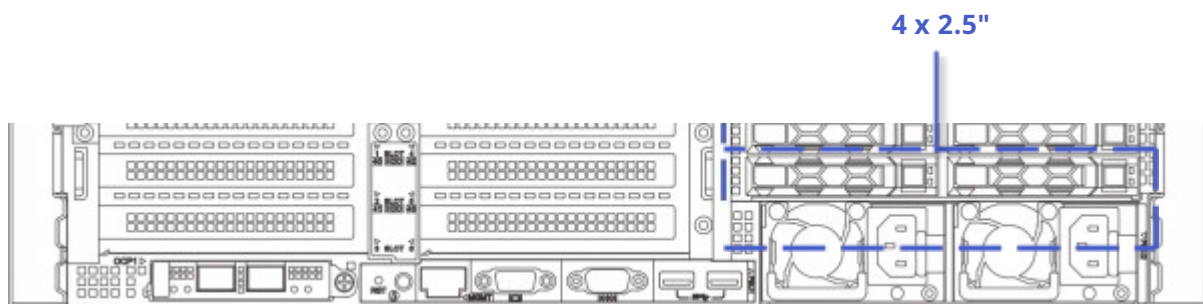

### 3.7 Back IO PCIe Configuration

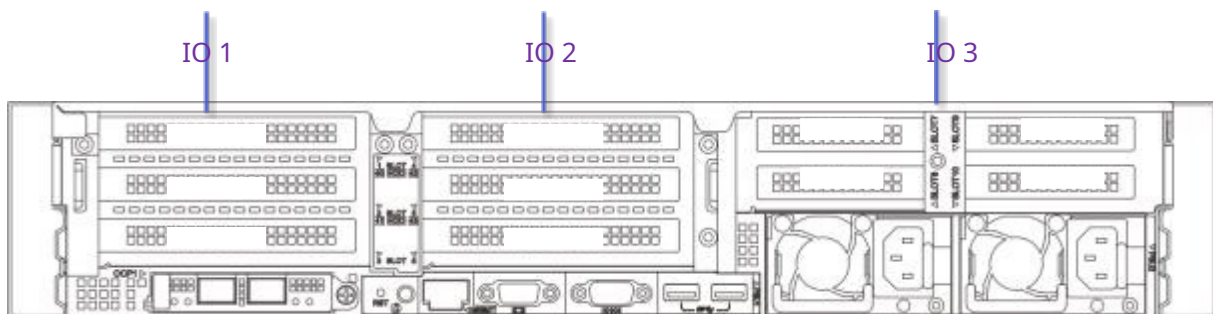

- IO Module 1 The provided slots are Slot 1 to Slot 2, 3;
- IO Module 2 provides slot 4. ~ Slot 6;
- IO Module 3 The provided slots are Slot 7 to Slot 10;
- IO Module 1 can be configured as a PCIe expansion module:
  - When configured as PCIe When expanding the module, 3 can be selected. PCIe x 16 or 2 PCIe x 8 Or 1 PCIe x 16+2 individual PCIe x 8 Or 1 individual x16

- IO Module 2 can be configured as a hard drive module or a PCIe module. Extended Modules:
  - When configured as a 2 x 2.5" hard drive module, Slot 4 ~ Slot 5 PCIe not supported Expansion card;
  - When configured as PCIe 3 can be selected when expanding the module PCIe x 16 or 2 PCIe x 8 or 1 PCIe x 16+2 PCIe x8 Or 1 individual x16;
- IO Module 3 can be configured as a hard drive module or a PCIe module. Extended Modules:
  - When configured as a 2 x 2.5" hard drive module, Slot 9 ~ Slot 10 PCIe not supported Expansion card;
  - When configured When using 4 x 2.5" hard drive modules, Slot 7 ~ Slot 10 PCIe not supported Expansion card;
  - When configured as PCIe 2 PCIe slots are available when expanding the module. x 8 or 2\* PCIe x 16 or 4\*x8;
- IO Module 1 IO module 2 IO Module 3 supports PCIe 5.0.

### PCIe Riser Module

- IO PCIe Riser Module 1 -- can provide 3 PCIe Slot Slot.
- Installed in IO PCIe Riser Module, providing PCIe Slot 1 Slot 2 Slot 3.

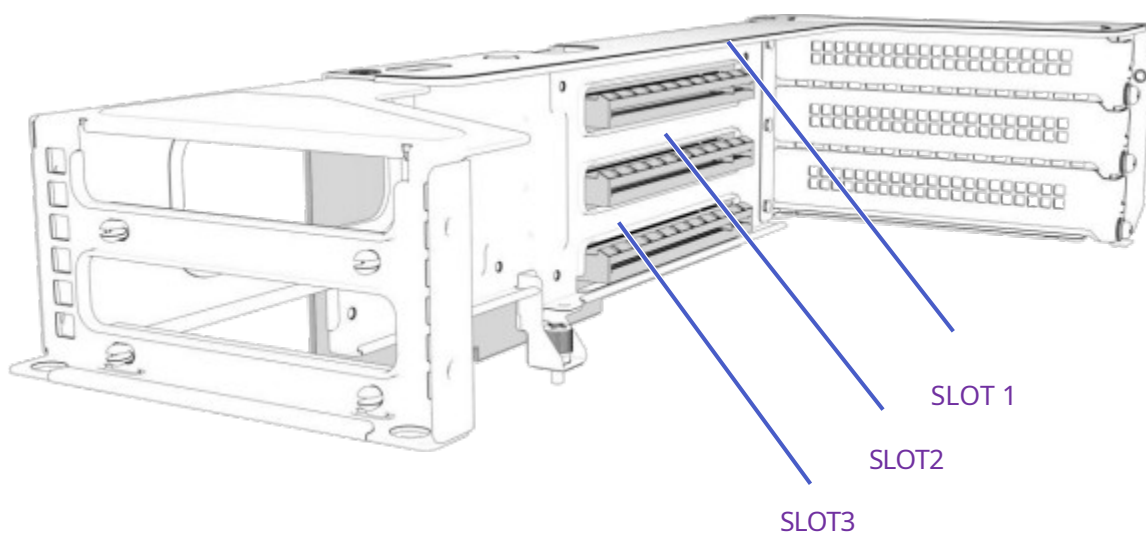

- IO PCIe Riser Module 1 -- can provide 2 PCIe Slot Slot.
- Installed in IO PCIe Riser Module, providing PCIe Slot 1 Slot 2.

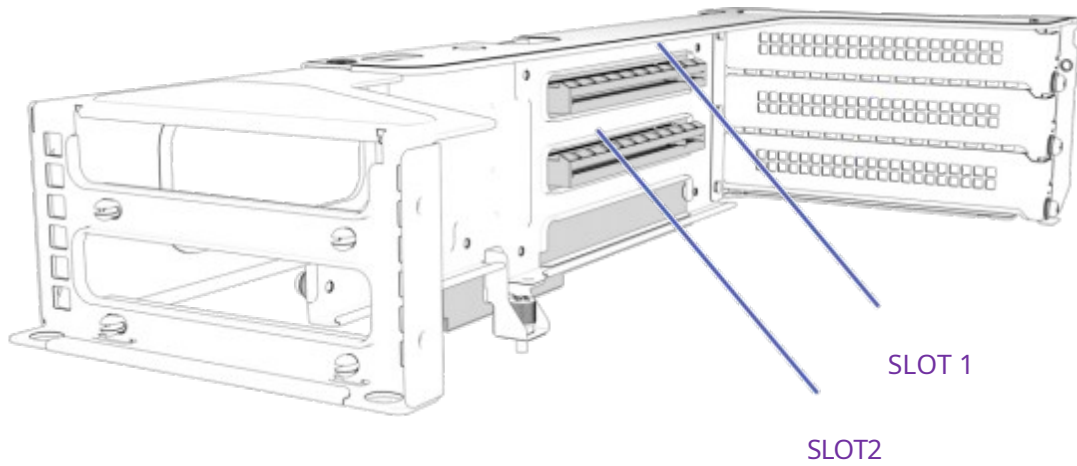

- IO PCIe Riser Module 1 -- can provide 1 PCIe Slot Slot .
- Installed in IO PCIe Riser Module, providing PCIe The slot is Slot 1.

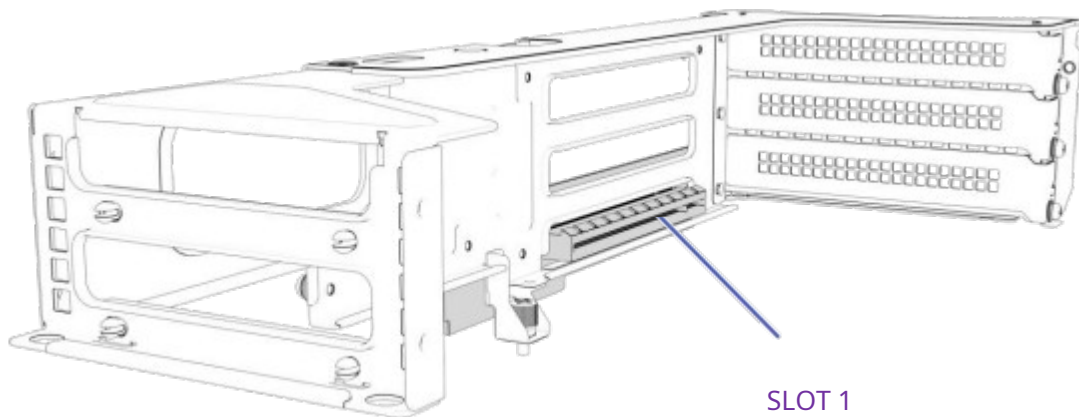

- IO PCIe Riser Module 2 -- can provide 3 indivual PCIe Slot Slot.
- Installed in IO PCIe Riser Module, providing PCIe Slot 4 Slot 5 Slot 6.

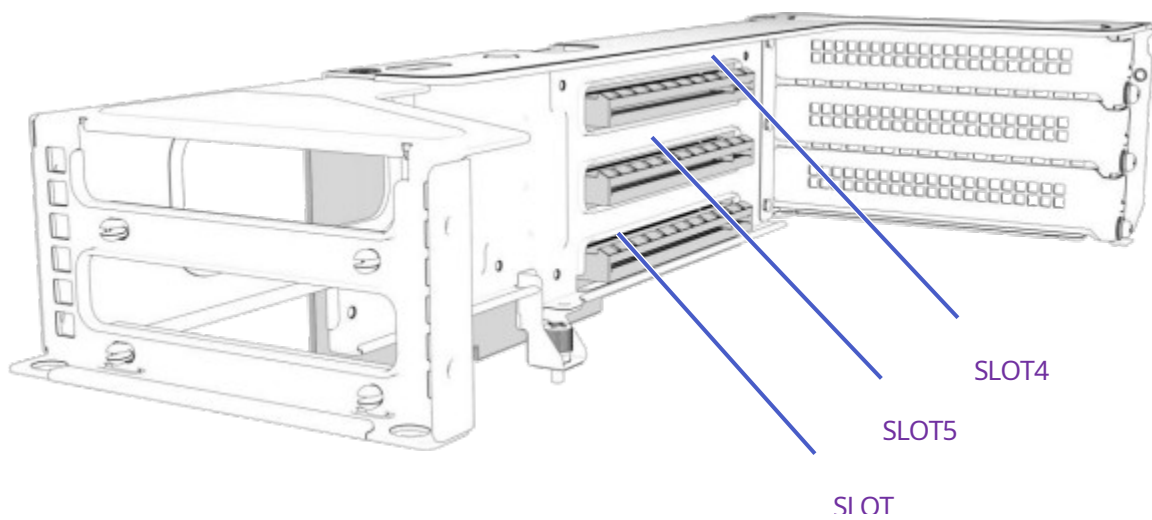

- IO PCIe Riser Module 2 -- can provide 2 individual PCIe Slot Slot.  
- Installed in IO PCIe Riser Module, providing PCIe Slot 4 Slot 5.

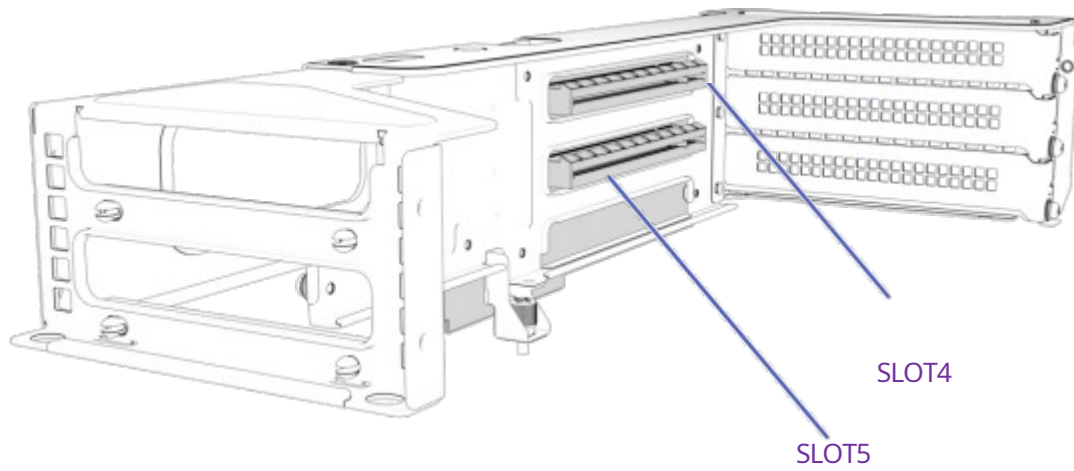

- IO PCIe Riser Module 2 -- can provide 1 PCIe Slot Slot.  
- Installed in IO PCIe Riser Module, providing PCIe The slot is Slot 4.

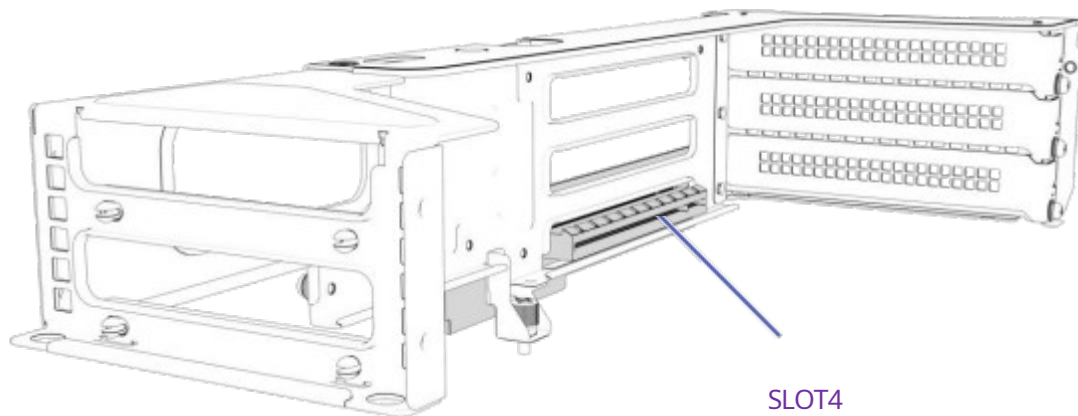

- IO PCIe Riser Module 2 -- can provide 1 PCIe Slot One bay plus two 2.5-inch hard drive bays.  
- Installed in IO PCIe Riser Module, providing PCIe The slot is Slot 4.

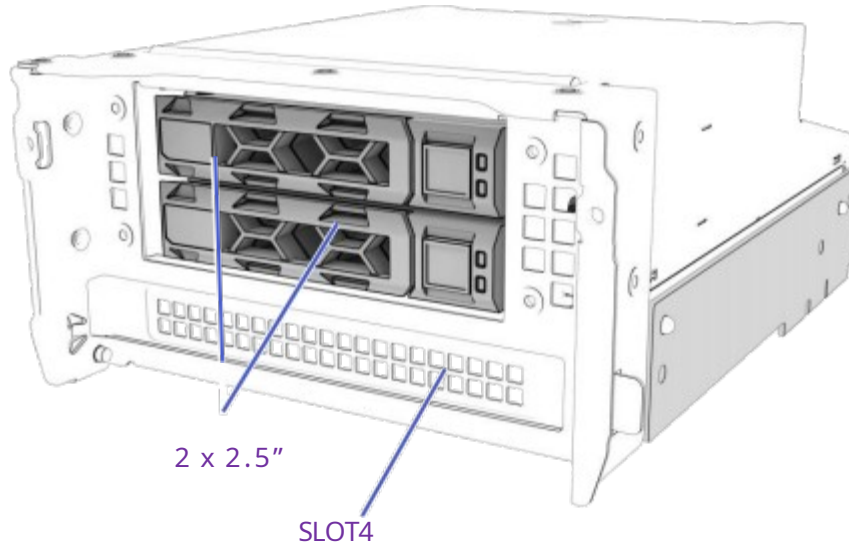

- IO PCIe Riser Module 3 -- can provide 4 individual PCIe Slot Slot.
- Installed in IO PCIe Riser Module 3 provides PCIe Slot 7 Slot 8 Slot 9 Slot 10.

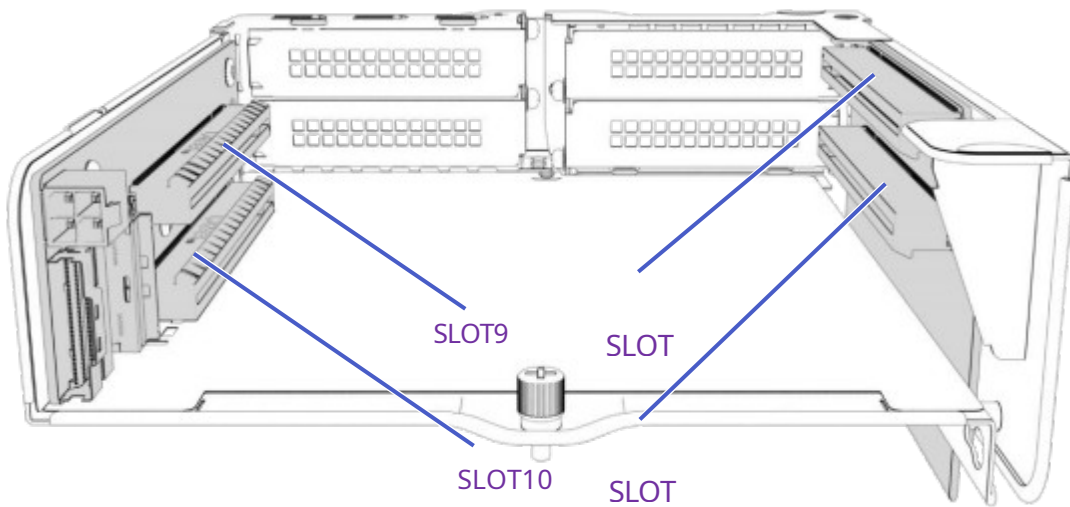

- IO PCIe Riser Module 3 -- can provide 2 individual PCIe Slot Slot.
- Installed in IO PCIe Riser Module 3 provides PCIe Slot 7 Slot 8.

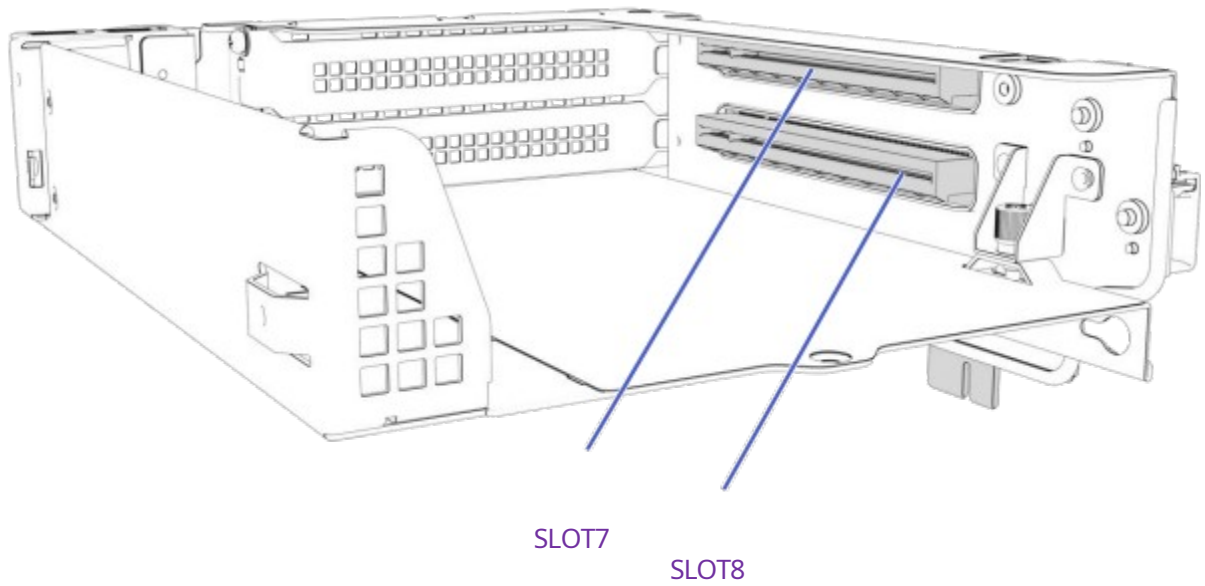

- IO PCIe Riser Module 3 -- can provide 4 One 2.5-inch hard drive bay.

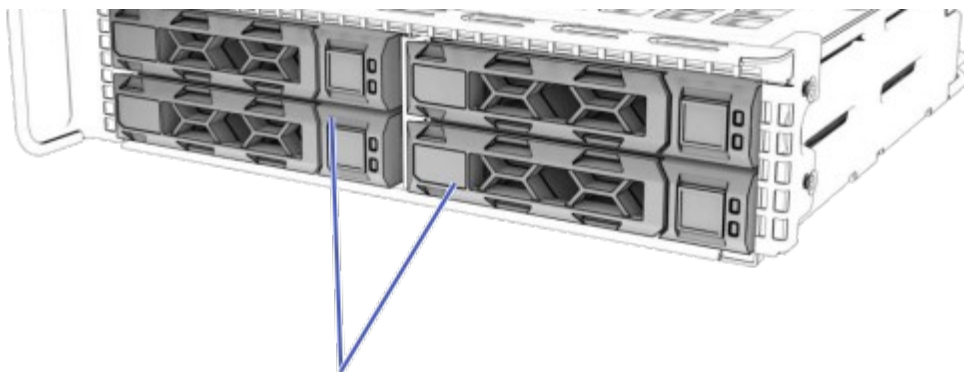

- IO PCIe Riser Module 3 -- can provide 2 individual PCIe Slot Slot +2 One 2.5-inch hard drive bay.
- Installed in IO PCIe Riser Module 3 provides PCIe Slot 7 Slot 8.

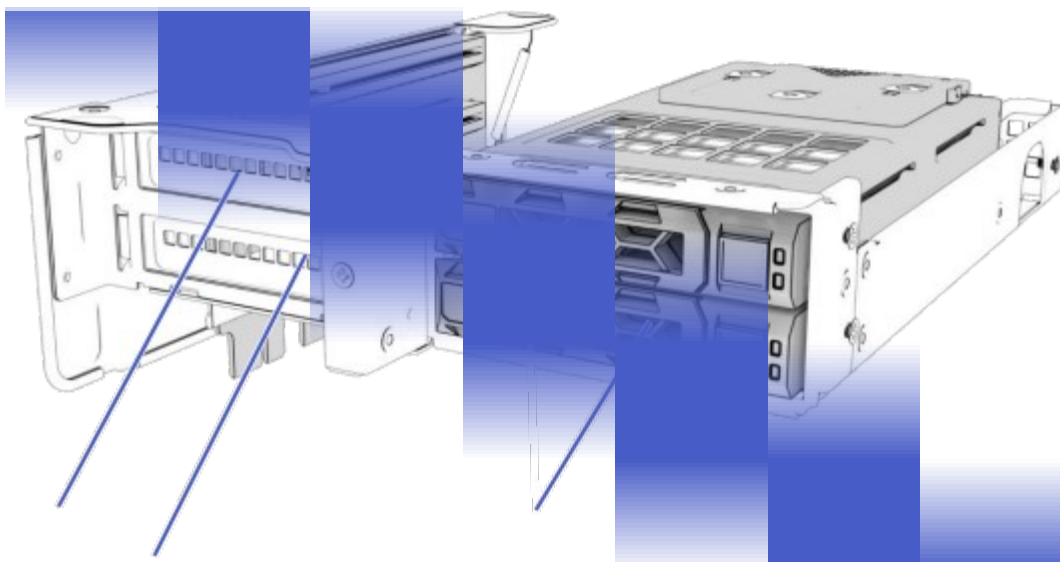

SLOT

### 3.8 PCIe Resource allocation rules

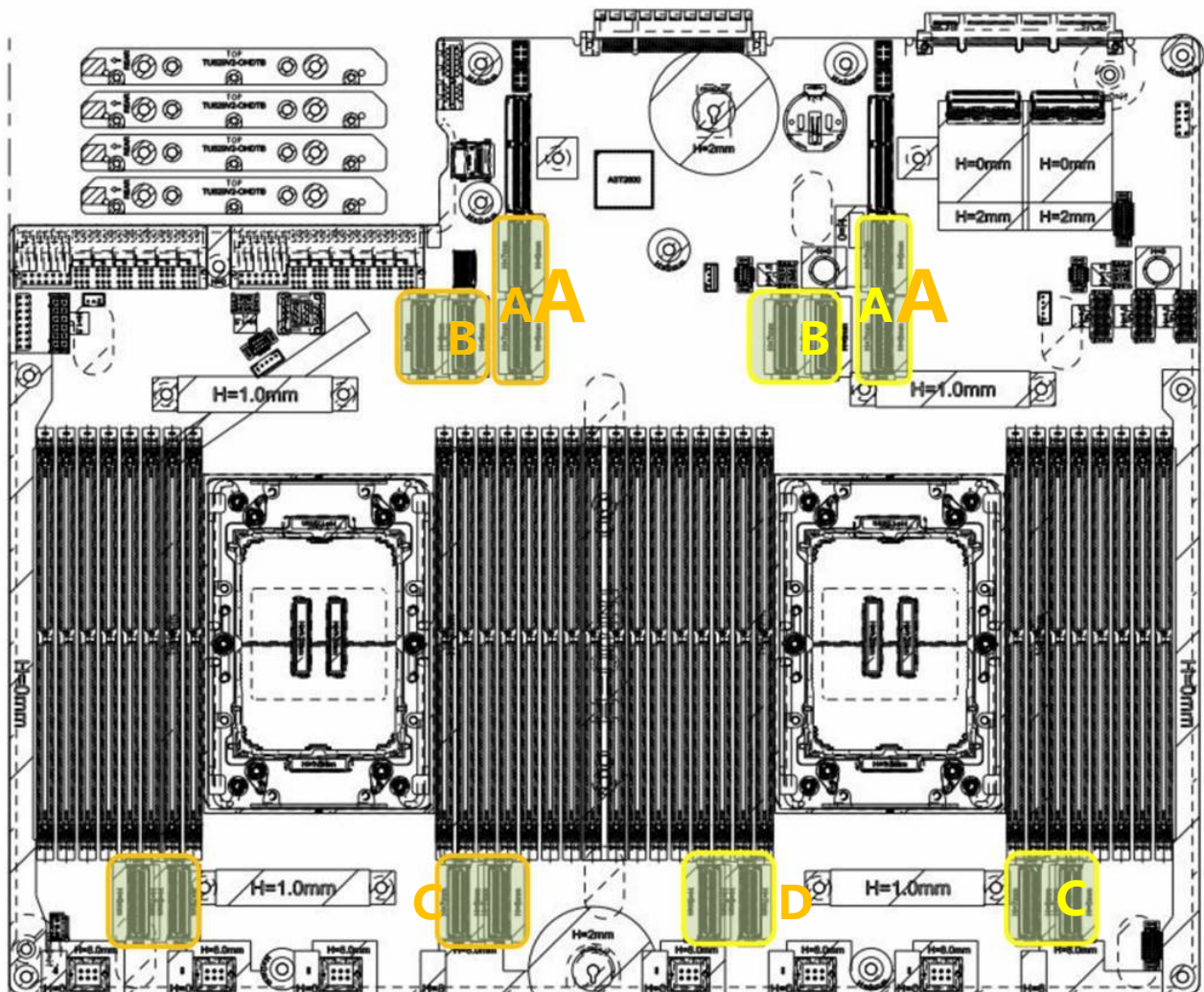

PCIe Resource Summary	CPU 0		CPU 1	
	MCIO x 8	MCIO x16	MCIO x 8	MCIO x16
South	4		4	
North	4	1	4	1

U.2 Configuration	8	12	16	twenty four
PCIe resource	C + D	C + D + D	C + D + C + D	B + C + D + B + C + D

<b>E3.S Configuration @1C</b>	8	16	twenty four	32
PCIe resource	C + D	C + D + C + D	B+C + D + B + C + D	A+B+C + D + A+B + C + D

<b>E3.S Configuration @2C</b>	4	8		16
PCIe resource	C + D	C + D + C + D		A+B+C + D + A+B + C + D

<b>Front PCIe Configuration</b>	superior	middle	Next-OCP
PCIe resource	B	B	D

<b>Rear PCIe Configuration</b>	IO -1	IO-2	IO-3	OCP
PCIe resource	A + B	A + B	B + B	B

### 3.9 Hard drive configuration

<b>Configuration</b>	<b>Front hard drive</b>	<b>Hard drive management methods</b>
----------------------	-------------------------	--------------------------------------

<p>2U8-3.5 SAS model (Front-panel hard drive connects to 95 series 8i memory card, supports front 8* SAS )</p>	<p>Front hard drive (8 × 3.5" Slots 0 through 7 support SAS / SATA hard drives .</p>	<p>SAS / SATA hard plate : 1 × RAID controller card</p>
<p>2U8-3.5 SATA model (Continued from M.2) SATA adapter card, supporting the first two SATA ports .</p>	<p>Front hard drive (2) × 3.5" Slots 0 and 1 support SAS / SATA hard drives .</p>	<p>SAS / SATA hard plate : 1 x M.2 SATA adapter card</p>
<p>2U8*3.5- NV model (Front hard drive connection) 95 series 8i memory card , catch plate load PCIe @ MCIO ( supports the first 8* SAS / NV )</p>	<p>Front hard drive (8 × 3.5" Slots 0 through 7 support SAS / SATA hard drives . Front hard drive (8 × 3.5" ); Slots 0 to 7 support NVMe SSDs</p>	<p>SAS / SATA hard plate : 1 × RAID controller card NVMe hard drives: MCIO interface</p>

<p>2U8*3.5- NV model (Pre-mounted hard) plate catch M.2 SATA Adapter card , connects to onboard PCIe @ MCIO , supports the first 8 * NV (compatible with 2 * SATA )</p>	<p>Front hard drive (8 × 3.5") Slots 0 through 7 support NVMe SSDs Slots 0 and 1 support SAS / SATA hard drives.</p>	<p>SAS / SATA hard drives: 1 × M.2 SATA adapter card NVMe hard drives: MCIO interface</p>
<p>2U12*3.5 direct connection - SAS model (Front hard drive) catch 95 Series 16i Memory card, supports up to 12* SAS )</p>	<p>Front hard drive (12 × 3.5") Slots 0 through 11 support SAS / SATA hard drives .</p>	<p>SAS / SATA hard drives: 1 × RAID controller card</p>
<p>2U12*3.5- NV model (Front hard drive) catch 95 Series 16i memory card , catch plate load PCIe @ MCIO ( supports the first 12* SAS / NV )</p>	<p>Front hard drive (12 × 3.5" ): Slots 0 to 11 support SAS / SATA hard drives Front hard drive (12 × 3.5" ) Slots 0 to 11 support NVMe SSDs</p>	<p>SAS / SATA hard drives: 1 × RAID controller card NVMe hard drives: MCIO interface</p>
<p>2U12*3.5- NV model (Pre-mounted hard) plate catch M.2 SATA Adapter card , connects to onboard PCIe @ MCIO , supports the first 12 * NV (compatible with 2 * SATA )</p>	<p>Front hard drive (12 × 3.5" ): Slots 0 to 1 support SAS / SATA hard drives Slots 0 through 11 support NVMe SSDs</p>	<p>SAS / SATA hard drives: 1 × M.2 SATA adapter card NVMe hard drives: MCIO interface</p>
<p>2U12-3.5 extended model (Connects to 95 series 8i memory card)</p>	<p>Front hard drive (12 × 3.5" )Slot 0 to Slot Bit 11 supports SAS / SATA hard drives</p>	<p>SAS / SATA hard drives: 1 × RAID controller card</p>
<p>2U8-2.5 direct connection - NVMe models  (Front hard drive connected to 95 series 8i storage)  Card, connect to onboard PCIe @ MCIO , supports  (Holding the first 8* NV / SAS )</p>	<p>Front hard drive (8 × 2.5" ): Slot 0 to  Slot 7 supports SAS / SATA hard drives  Front hard drive (8 × 2.5" )Slot 0 to slot  7-bit supports NVMe hard drives</p>	<p>SAS / SATA hard drives: 1 × RAID controller card NVMe SSDs: MCIO Interface</p>
<p>2U16-2.5 direct connection - NVMe models</p>	<p>Front hard drive (16 × 2.5" ):</p>	

<p>(Front hard drive connected to 95 series 8i storage)</p> <p>Card, connect to onboard PCIe @ MCIO , supports</p> <p>Supports the first 16* NV (compatible with 8* SAS)</p>	<p>Slots 0 to 7 support SAS / SATA hard drives.</p> <p>Front hard drive (16 × 2.5" ) Slot 0 to</p> <p>Slot 15 supports NVMe SSDs</p>	<p>SAS / SATA hard drives: 1 × RAID controller card NVMe SSDs: MCIO Interface</p>
<p>2U16*2.5- NV + front I/O model</p> <p>(First 16* NV (compatible with 8* SAS ))</p> <p>(Front hard drive connected to 95 series 8i storage)</p> <p>Card, connect to onboard PCIe @ MCIO , supports</p> <p>Supports up to 16* NV (compatible with 8* SAS );</p> <p>Front camera supports 2x16, but front camera is not supported.</p> <p>OCP )</p>	<p>Front hard drive (16 × 2.5" ): Slots 0 to 7 support SAS / SATA hard drives.</p> <p>Front hard drive (16 × 2.5" ) Slot 0 to</p> <p>Slot 15 supports NVMe SSDs</p>	<p>SAS / SATA hard drives: 1 × RAID controller card NVMe SSDs: MCIO Interface</p>
<p>2U16*2.5- NV + front I/O model</p> <p>(8 * NV + 8 * SAS )</p> <p>(Front hard drive connected to 95 series 8i storage)</p> <p>Card, connect to onboard PCIe @ MCIO , supports</p> <p>Supports 8* NV + 8* SAS ; front-end support</p> <p>Supports 2x16, supports front-facing OCP )</p>	<p>Front hard drive (8 × 2.5" ): Slots 8 to 15 support SAS / SATA hard drives.</p> <p>Front hard drive (8 × 2.5" ) Slot 0 to</p> <p>Slot 7 supports NVMe SSDs</p>	<p>SAS / SATA hard drives: 1 × RAID controller card NVMe SSDs: MCIO interface</p>
<p>2U24*2.5- NV model</p> <p>(Front hard drive connected to 95 series 8i storage)</p> <p>Card, connect to</p>	<p>Front hard drive (8 × 2.5" ): Slots 0 through 7 support SAS / SATA hard drives.</p> <p>Front hard drive (24 × 2.5" ) Slot 0 to</p>	<p>SAS / SATA hard drives: 1 × RAID controller card NVMe SSDs:</p>

<p>onboard PCIe @ MCIO , supports</p> <p>Supports the first 24* NV (compatible with 8 SAS )</p>	<p>Slot 23 supports NVMe SSDs</p>	<p>MCIO Interface</p>
<p>2U24*2.5- NV model</p> <p>(A 95 series sheet is attached to both the front and back panels)</p> <p>8i memory card, onboard connector</p> <p>PCIe @ MCIO , supports front</p> <p>24* NV (compatible with 4 SAS )</p>	<p>Front hard drives (4) × 2.5" ): Slots 0 through 3 support SAS / SATA hard drives.</p> <p>Front hard drive (24 × 2.5" ) Slot 0 to</p> <p>Slot 23 supports NVMe SSDs</p>	<p>SAS / SATA hard drives: 1 × RAID controller card</p> <p>NVMe SSDs:</p> <p>MCIO Interface</p>

<p>2U25-2.5 Extended Model</p> <p>(Connects to 95 series 8i memory card)</p>	<p>Front hard drive (25 × 2.5" ): Slots 0 to 24 support SAS / SATA hard drives.</p>	<p>SAS / SATA hard drives: 1 × RAID controller card</p>
<p>2U16*E3.S 1T1C model</p> <p>(Connects to onboard PCIe @ MCIO , supports)</p> <p>First 16*E3.S 1T)</p>	<p>Front hard drive (16 × E3.S 1T ): Slots 0 to 15 support NVMe SSDs</p>	<p>NVMe SSDs:</p> <p>MCIO Interface</p>
<p>2U24*E3.S 1T1C model</p> <p>(Connects to onboard PCIe @ MCIO , supports)</p> <p>The first 24*E3.S 1T)</p>	<p>Front hard drive (24 × E3.S 1T ): Slot 0</p> <p>Slot 23 supports NVMe SSDs</p>	<p>NVMe SSDs:</p> <p>MCIO interface</p>

<p>2U32*E3.S 1T1C model</p> <p>(Connects to onboard PCIe @ MCIO , supports)</p> <p>The first 32*E3.S 1T)</p>	<p>Front hard drive (32 × E3.S 1T ): Slot 0</p> <p>Slot 31 supports NVMe SSDs</p>	<p>NVMe SSDs: MCIO interface</p>
--	---	--

### 3.10 Hard drive label

- 2U8 bays, 3.5 inches inch disk model

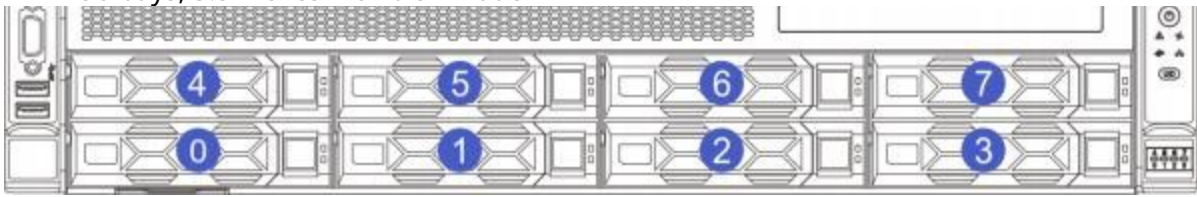

- 2U12 drive bays 3.5" inch disk model

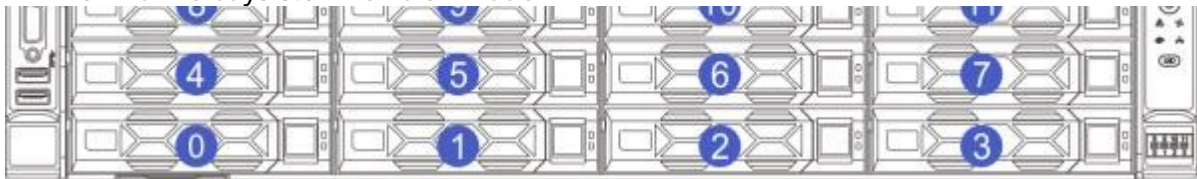

- 2U8 bays, 2.5" inch disk model

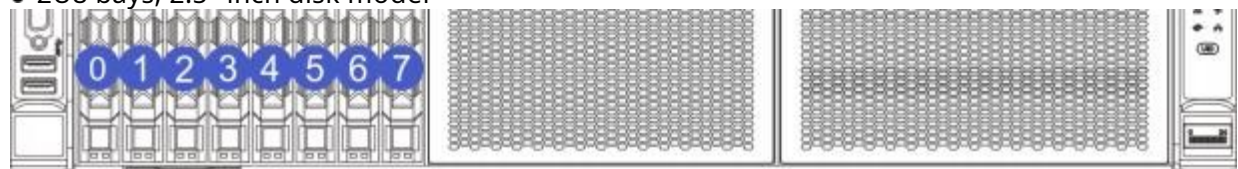

- 2U16 2.5 sq m inch disk model

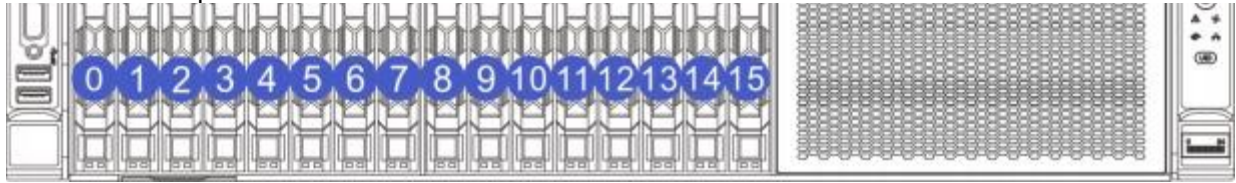

- 2U24 bays, 2.5" inch disk model

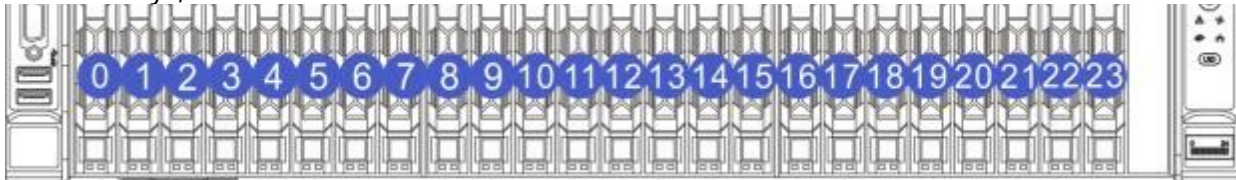

### 3.11 Hard drive indicator light

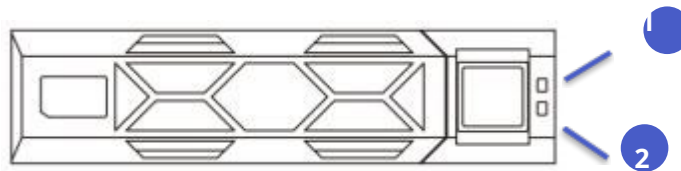

1 Hard drive Fault indicator lights	2: Hard drive Present / Active indicator lights
-------------------------------------	---

SAS / SATA Hard drive indicator light description:

Hard drive status	harddisk Present / Active Indicator light (green)	harddisk Fault Indicator light (yellow)
Hard drive not in place	Extinguish	Extinguish
The hard drive is in place, but there is no data activity.	Chang Liang	Extinguish
The hard drive is in place and functioning normally.	blinking	Extinguish
Hard drive failure	Chang Liang	Chang Liang
Hard drive located	Chang Liang	Flickering (4Hz)
The hard drive is in Rebuild mode state	Chang Liang	Flickering (1 Hz)

NVMe Hard drive indicator light description:

Hard drive status	harddisk Present / Active Indicator light (green)	harddisk Fault Indicator light (yellow)
Hard drive not in place	Extinguish	Extinguish
The hard drive is in place, but there is no data activity.	Chang Liang	Extinguish
The hard drive is in place and functioning normally.	blinking	Extinguish
Hard drive failure	Chang Liang	Chang Liang
Hard drive located	Chang Liang	Flickering (4Hz)

### 3.12 System Fan

The server supports automatic fan speed control, with the fan speed dynamically adjusted according to the system temperature, effectively reducing system noise and power consumption.

- support 4 Each fan module can be paired with an 8056 processor depending on the configuration. Fan of the specified specifications.
- Supports hot-swapping.
- support N+1 Redundancy means that the server can continue to function normally even if a single fan fails.
- Supports intelligent fan speed adjustment.
- Fan modules configured on the same server, Part No. (i.e., P/N) The encoding must be the same.

### 3.13 Power module

- support 1 One or 2 One power module.
- Supports AC or DC power supply modules.
- Supports hot-swapping.
- Configuration 2 When using a power module support 1+1 Redundant backup.
- Power modules configured on the same server, Part No. (i.e., P/N) The encoding must be the same.
- Provides short-circuit protection. A power module that supports dual live wire input. The power module location is shown in the image below:

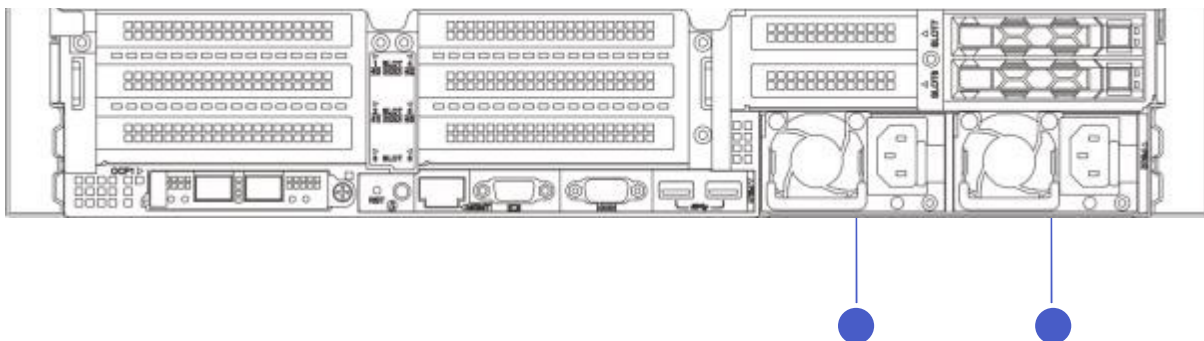

## 4. Operating system compatibility

For information on operating system and hardware compatibility, please refer to this section. For the latest compatibility information and product component models not listed in this manual, please consult your local sales representative at Tongtaiyi.

### 4.1 operating system

surface 4-1 operating system

OS factory	OS Version
Windows	Windows Server 2022 Windows Server 2025
Red Hat	Red Hat Enterprise Linux 9.4 Red Hat Enterprise Linux 9.2 Red Hat Enterprise Linux 8.7
SUSE	SUSE Enterprise Linux SLE 15 SP4
Ubuntu	Ubuntu Server 24.04.1 LTS Ubuntu Server 22.04.4 LTS
Oracle	Oracle Linux 9.0
Rocky	Rocky Linux 9.3 Rocky Linux 8.6
CentOS	CentOS 8.4
VMWare	VMWare ESXi 8.0
Citrix Hypervisor	Citrix Hypervisor 8.2 LTSR
UOS	UOS Server V 20
Galaxy Kirin	Galaxy Kirin kylin V 10
Euler	Open Euler 22.03 LTS

## 5. Install system components

### 5.1 Chassis top cover installation

Step 1 Install the front cover of the chassis.

1-1. Align the top cover with the opening of the box and place it downwards.

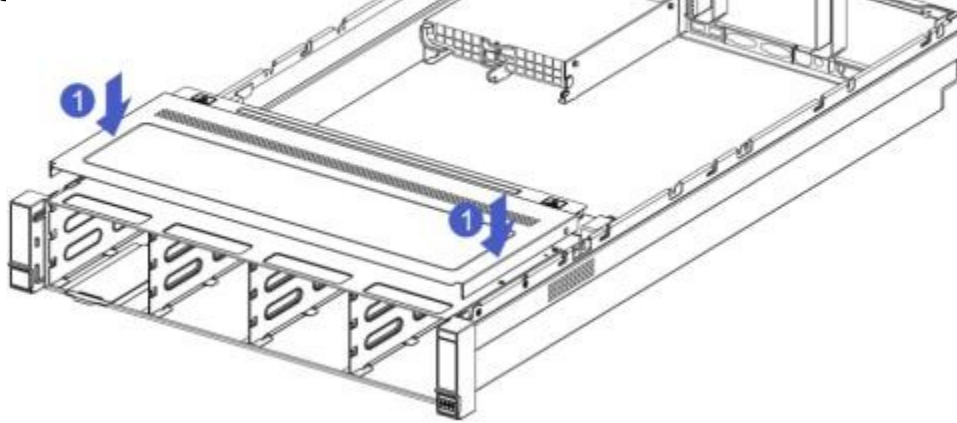

1-2. Push the front cover in the direction of the arrow until it is flush with the front of the chassis and the latches on both sides click into place.

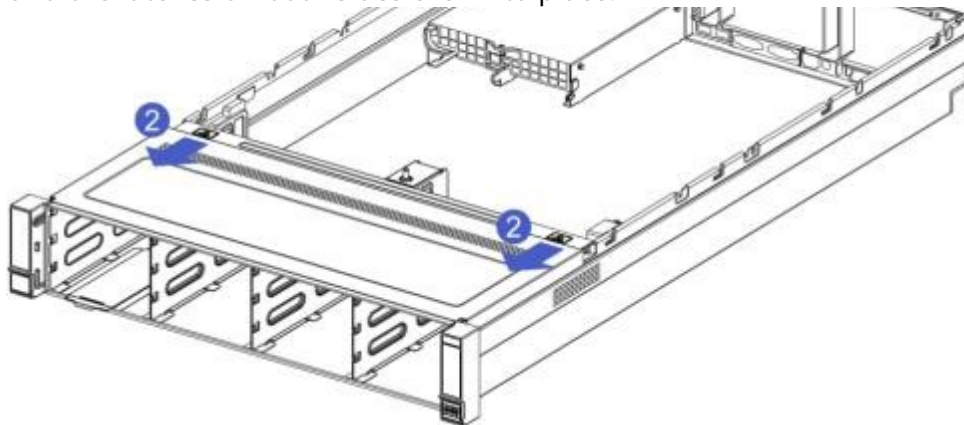

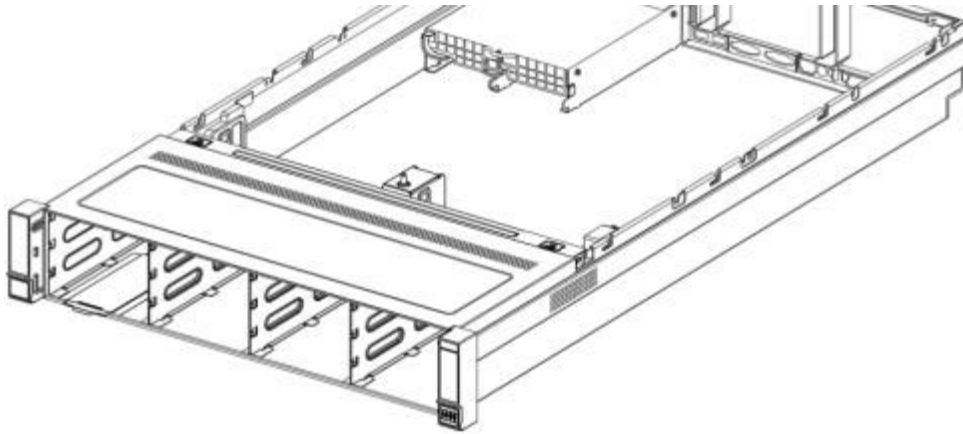

Step 2: Install the rear cover of the chassis

2-1. Open the chassis latches in the direction of the arrow, align the top cover hooks with the opening of the chassis, and place it downwards.

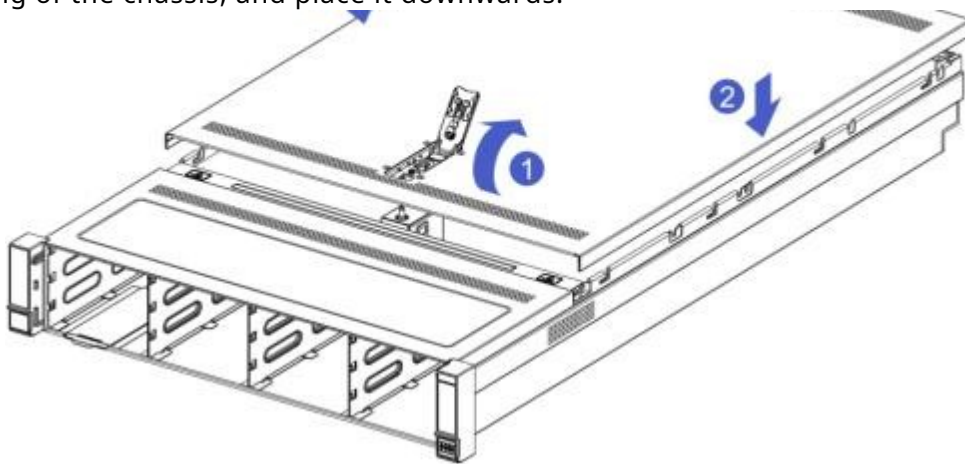

2-2. Rotate the top cover latch in the direction of the arrow until it locks in place.

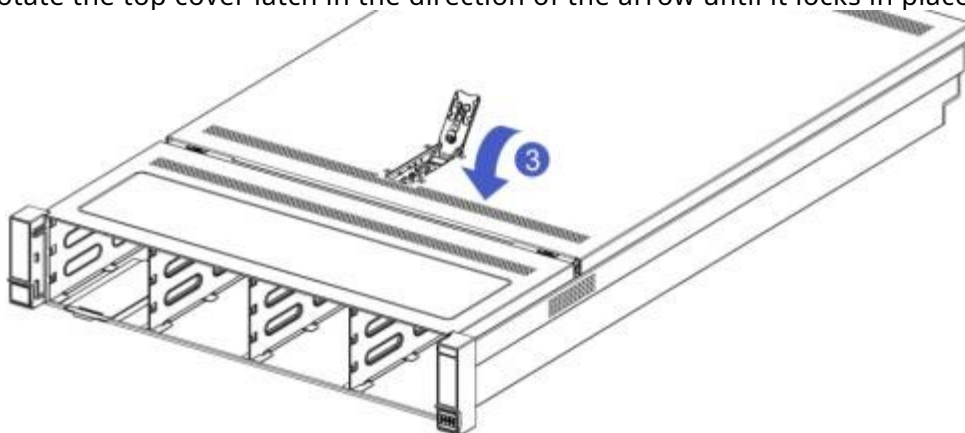

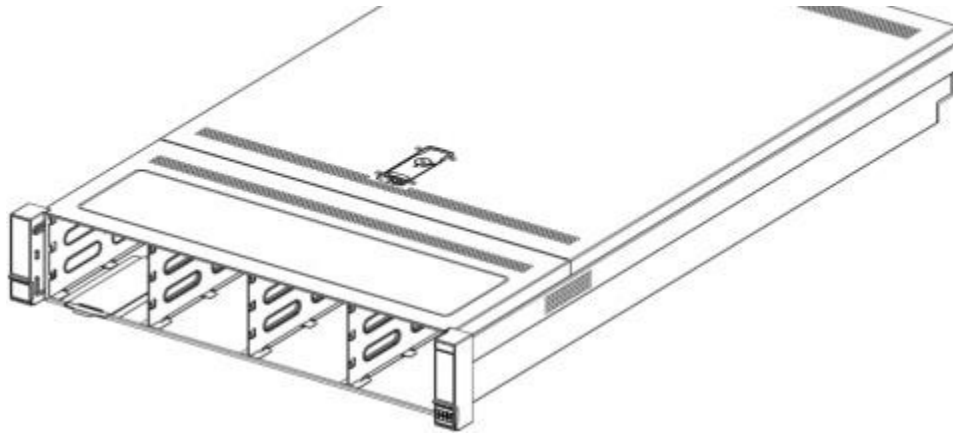

warning

- To reduce the risk of personal injury from overheating server surfaces, please touch the drives and internal system components only after they have cooled down.
- 

## 5.2 Radiator installation

Installation steps:

1. Press the protective cover upwards in the direction of the arrow and remove it;
2. Move the locking clips on the radiator in the direction of the arrow until they are in a vertical position. Align the heatsink with the heatsink mounting studs on the CPU socket. Place it vertically downwards on the base;
3. Press the fastening latch on the radiator in the direction of the arrow. Make it lock into the hook of the processor base;
4. Using T30 Tighten the screws securing the radiator with a Torx screwdriver.

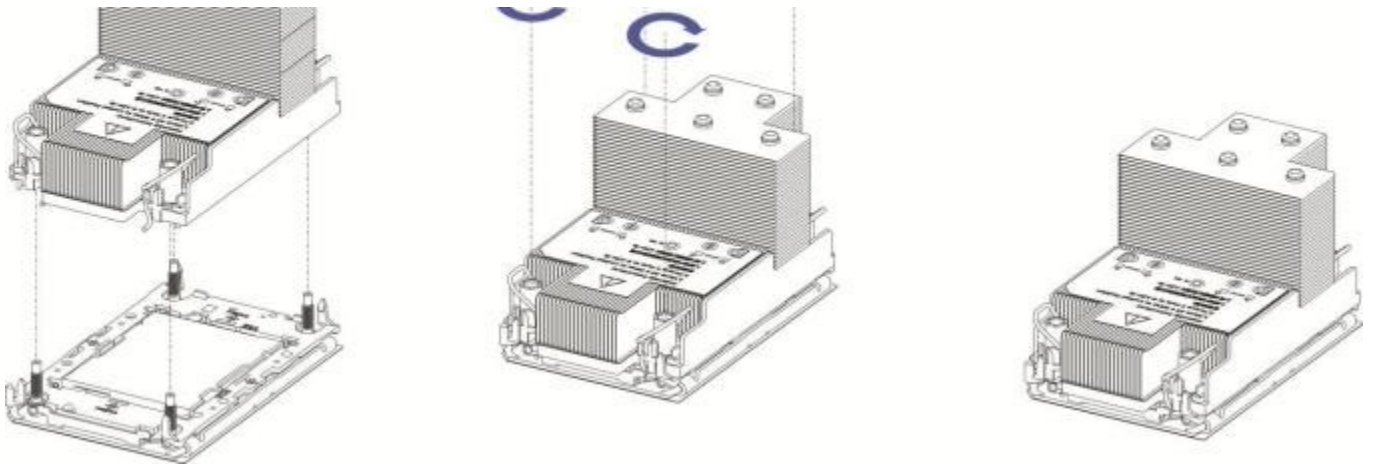

#### Notice

- The pins on the motherboard are extremely fragile and easily damaged. To avoid damaging the motherboard, do not touch the processor or processor socket contacts.
- 



#### Danger

- After disconnecting the server power, the heatsink may be hot. Please allow the heatsink to cool down for a few minutes before installation.
- 

## 5.3 Memory installation

Step 1 Open the levers on both sides of the memory slot, align the memory module with the memory slot, making sure the notch on the memory module matches the memory slot; Step 2 Forcefully insert the memory module vertically into the memory slot. Until I heard the sound of the memory wrench locking.

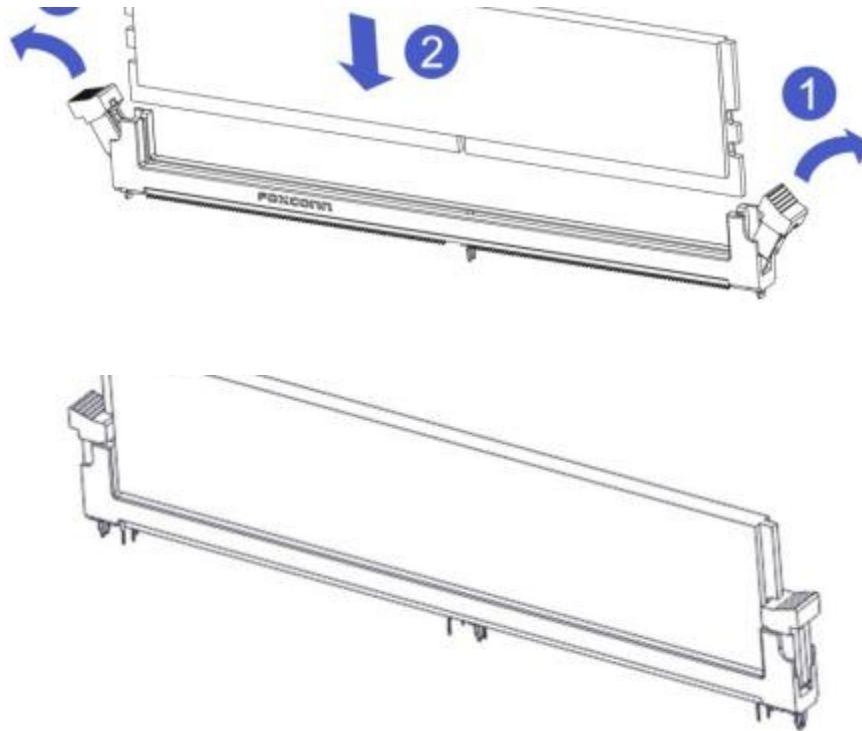

## 5.4 Hard drive installation

- Install a 3.5-inch hard drive

1-1. Place the hard drive in the tray;

1-2. Both sides 4 Secure the hard drive with a countersunk screw (the screw head must not protrude from the surface of the slide rails on both sides of the tray).

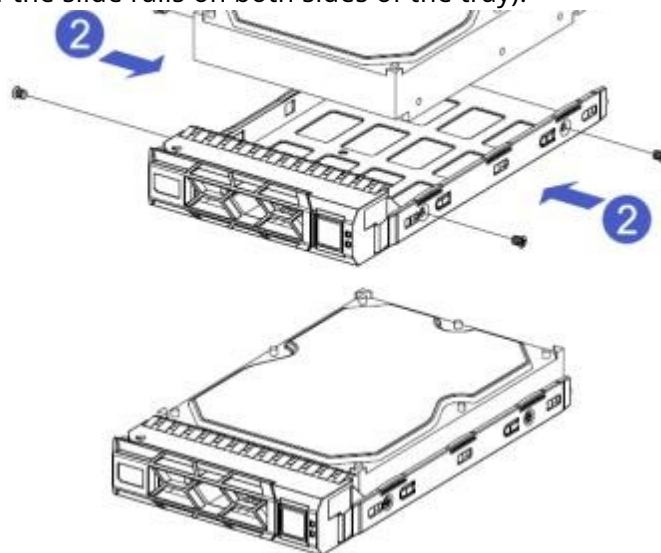

- Install a 2.5-inch hard drive
- 1-1. Place the hard drive in the tray;

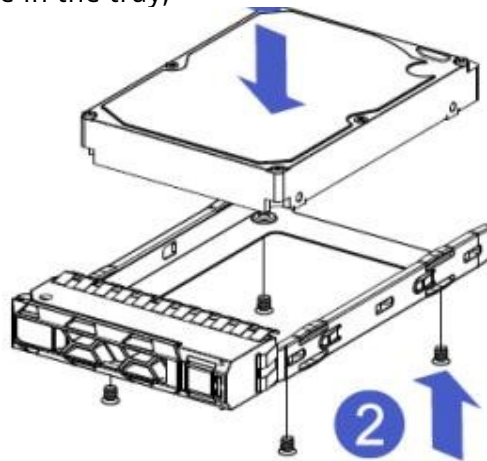

- Hard drive tray assembly installed in the chassis
1. With the hard drive lever open, push it into the computer case;
  2. When the hard drive's gold fingers touch the backplane components, turn the wrench in the direction of the arrow;
  3. Diagram showing hard drive installation:

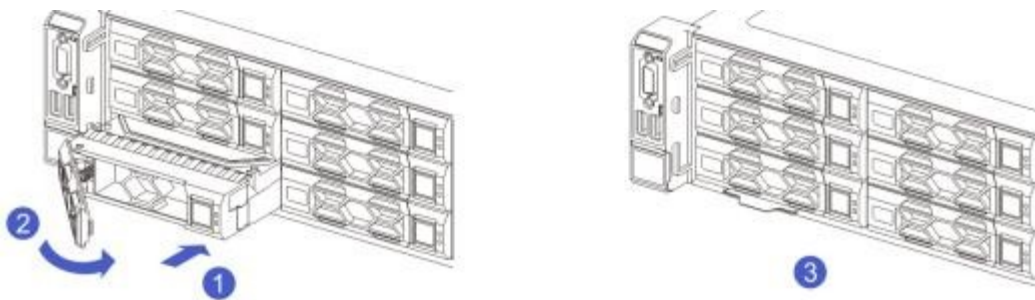

## 5.5 M.2 Installation

Step 1. Install the positioning studs according to the length of the M.2 card to be installed;

Step 2: Install the M.2 card

2-1. As shown in the diagram, insert the M.2 card connector into the motherboard connector;

2-2. Press the other end of the M.2 card onto the locating stud plane from step 1. Step 3: Install the

M.2 card's retaining screws.

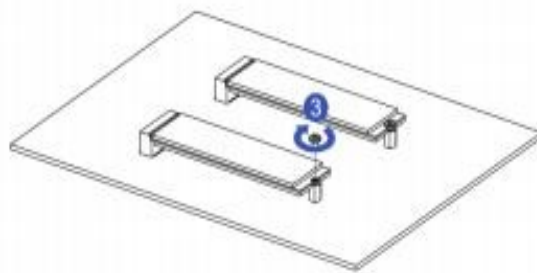
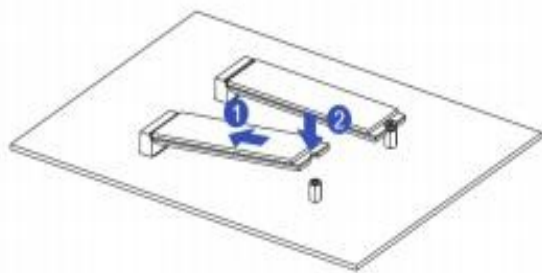

## 5.6 IO 1 and IO 2 Module installation

- IO 1 and IO 2 Module 1 (3 xPCIe & 2 PCIe) Installation method for the module:

Step 1. Rear window PCIe component, vertically downward and aligned with PCIe Align the slot with the positioning hole. Position it flush with the rear window. Step 2. Use a Phillips screwdriver to tighten the screws securing the module.

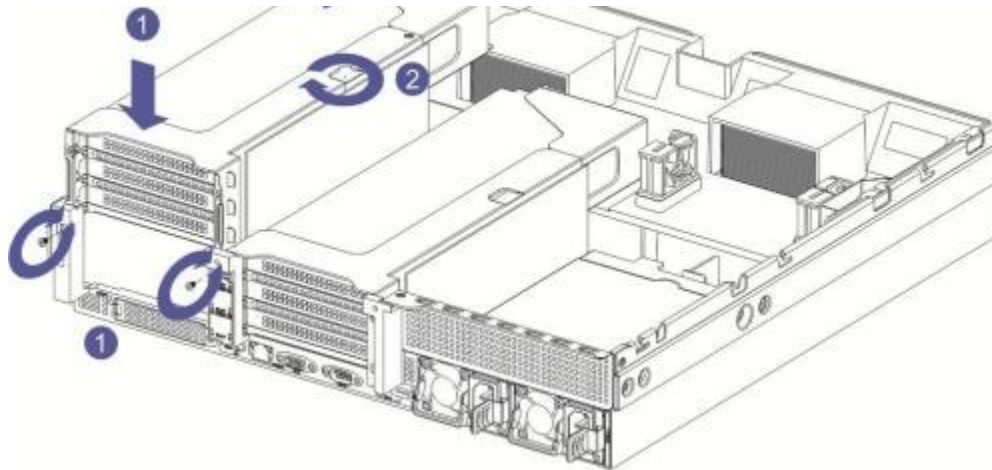

- IO 1 and IO 2 Module 2 (2x3.5" hard drive modules) Installation method: Step 1. The hard drive enclosure is placed vertically downwards, flush with the rear window. Step 2. Use a Phillips screwdriver to tighten the screws securing the module.

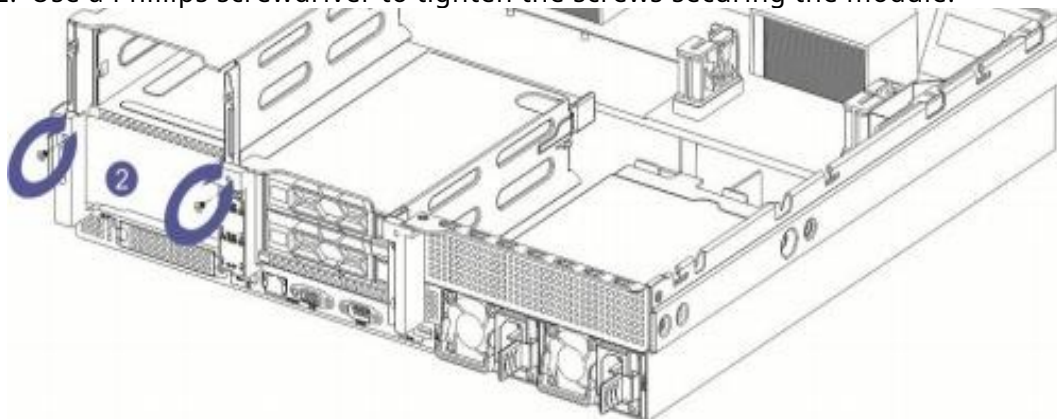

## 5.7 IO 3 Module installation

- IO 3 Module 1 (4x2.5) Installation

method for (inch hard drive enclosure): Step

1. Place vertically downwards. Align with the guide pin at the lower end.

Step 2. After leveling the surface, use a Phillips screwdriver to tighten the screws securing the module .

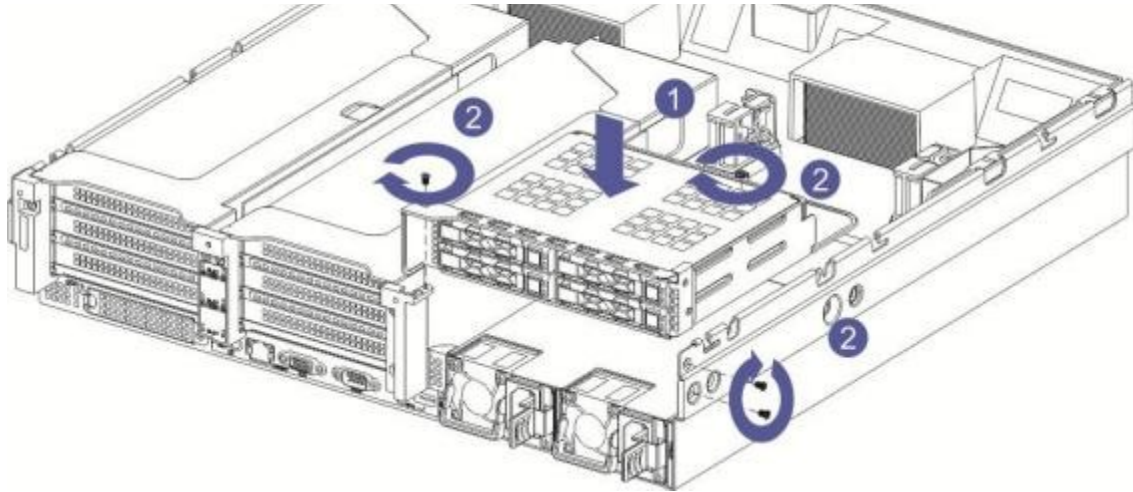

- IO 3 Installation method for Module 2 (2

xPCIe full-height modules): Step 1. Place

vertically downwards. Align with the guide pin at the lower end.

Step 2. After leveling the surface, use a Phillips screwdriver to tighten the screws securing the module .

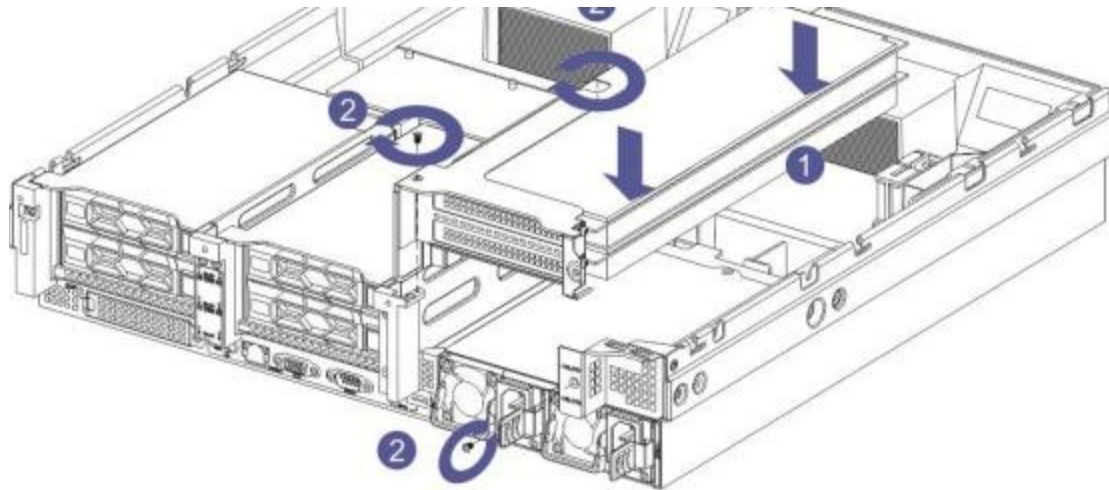

## 5.8 OCP Network card installation

- Step 1. OCP Align the expansion network card with the slide rail on the rear window of the chassis and push it in. Continue until it cannot be pushed further, then check if the mounting surface of the non-removable screw is flush with the rear window surface;

Step 2. Tighten the mounting screws of the flexible I/O card with a Phillips screwdriver.

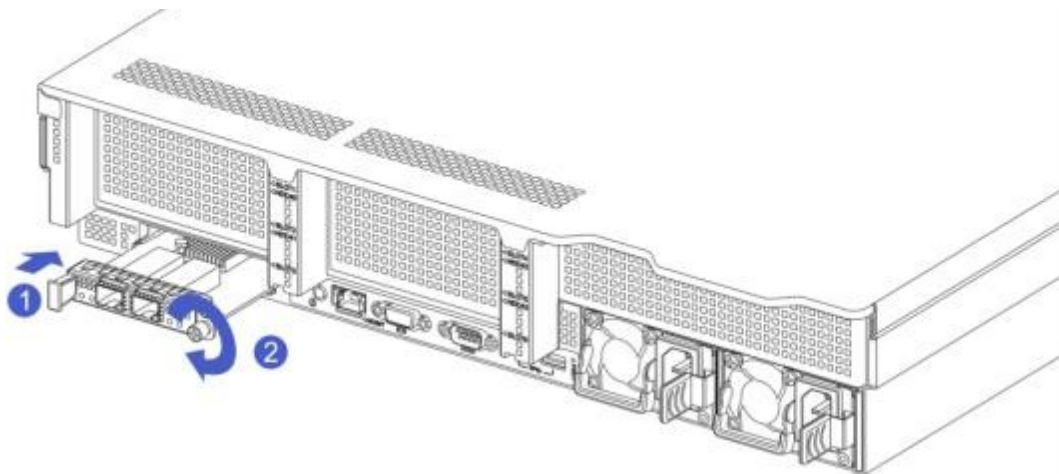

## 5.9 Power module installation

Steps: Push the power supply all the way in the direction of the arrow. After the right-side spring lever makes a click, This indicates that the installation is complete;

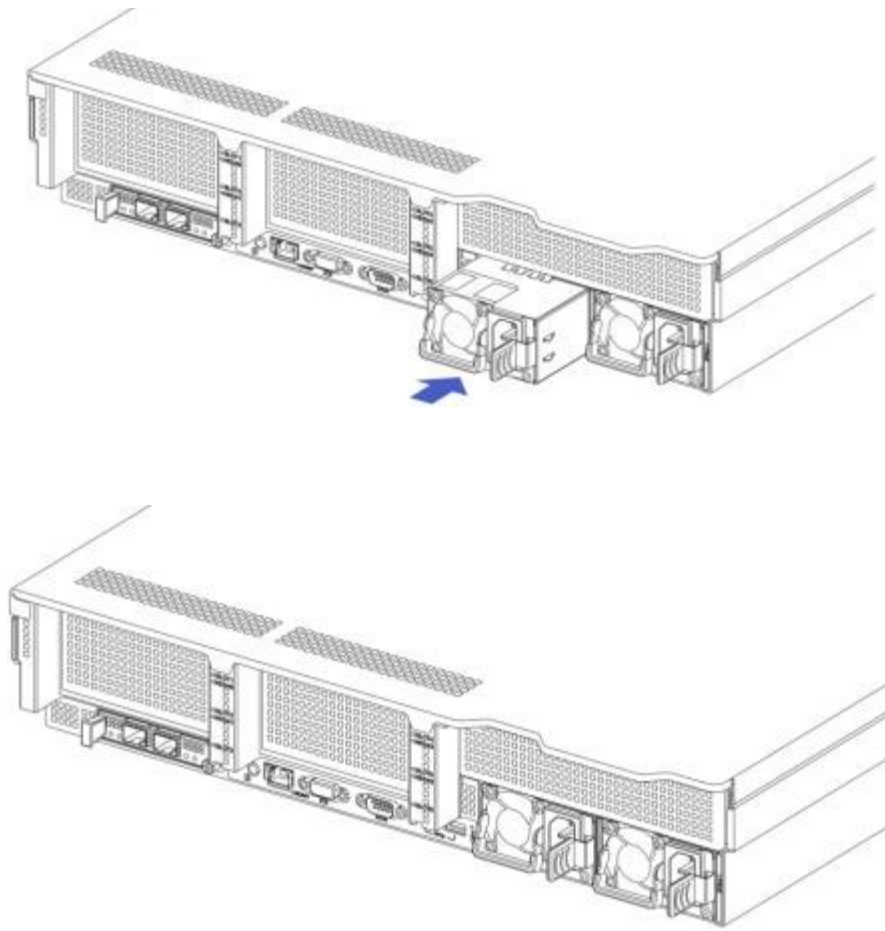

## 5.10 Fan Module Installation

Steps: Place the fan module vertically downwards in the position as indicated by the arrow (note the orientation of the fan module)

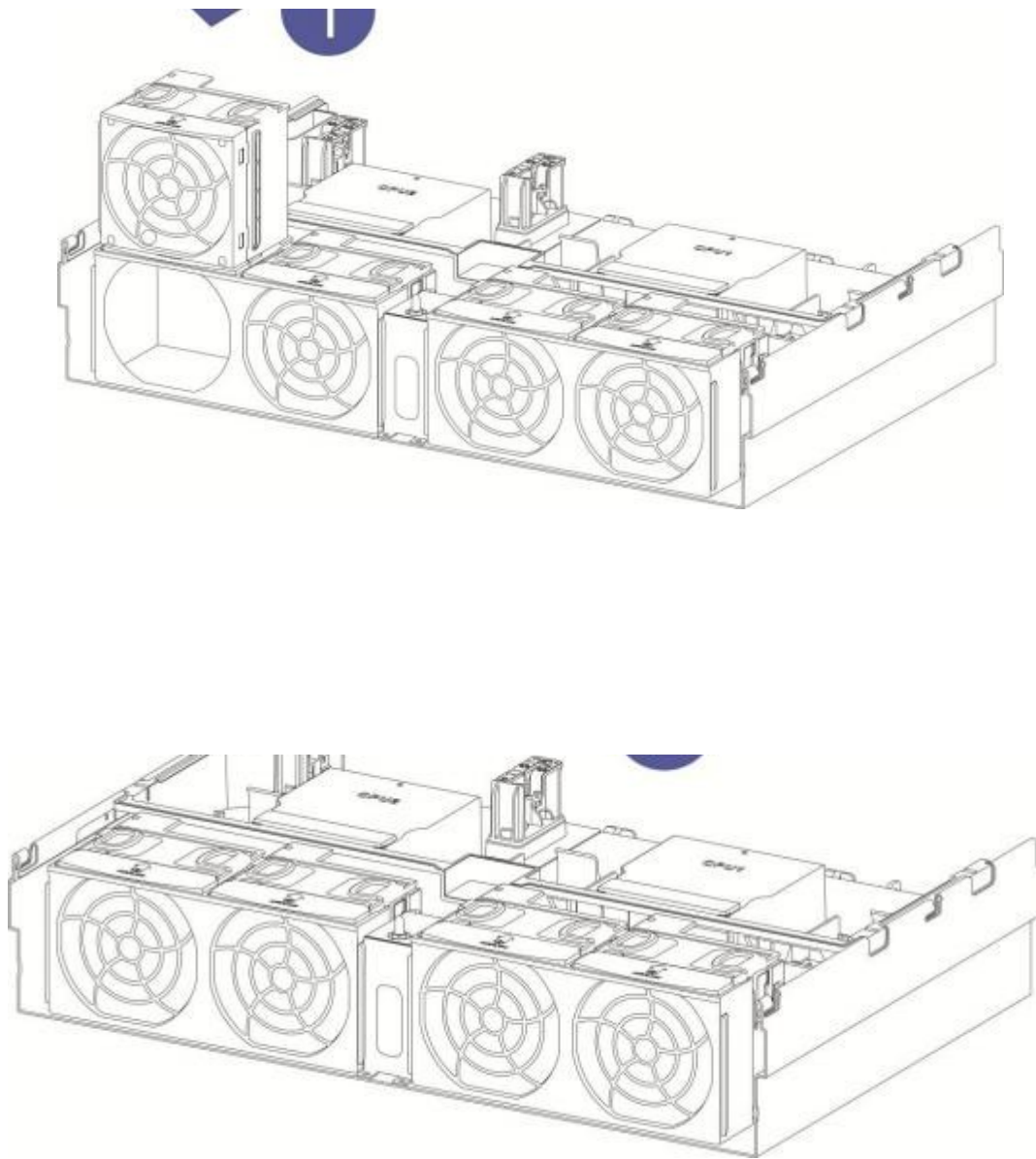

## 5.11 Installation of the air guide cover

step: Align the air guide module with the hanging points on the left and right sides and place it vertically downwards - at a height lower than the height of the box

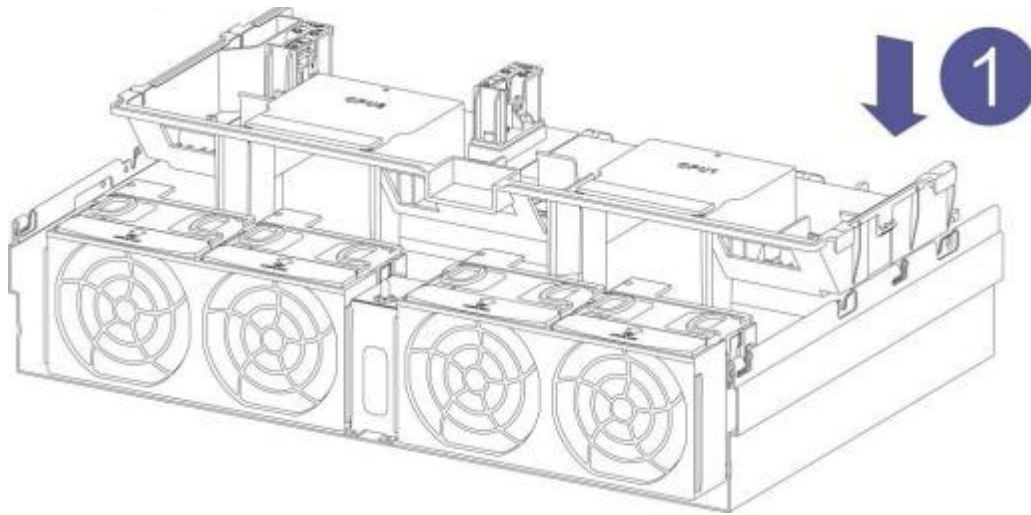

## 5.12 RAID Card battery pack installation

There are 3 on the air guide cover The battery pack placement area can support up to 3 One RAID card battery pack. Installation steps: Align the battery pack with the battery pack mounting slot on the air guide in the direction of the arrow and place the battery pack there.

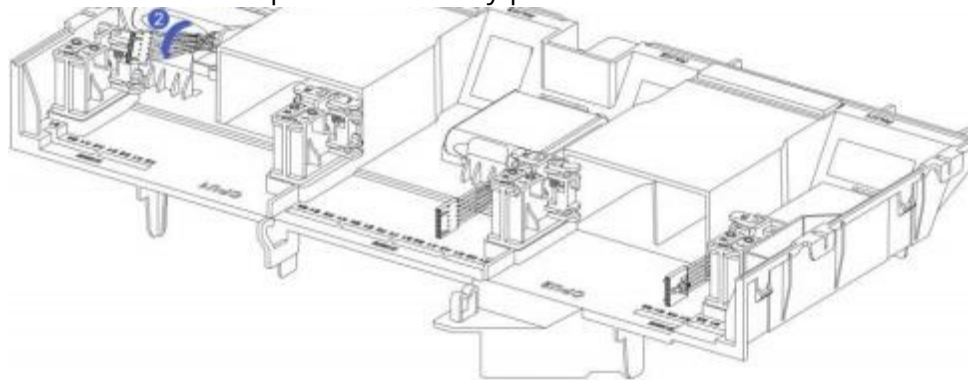

## 5.13 Guide rail assembly installation

Step 1. After removing the inner rail from the guide rail, push the middle rail into the guide rail.

1-1. Pull the inner rail out of the guide rail until you hear a click and it stops. 1-2. Push the white button in the direction of the arrow and pull the inner rail out completely .

1-3. Complete the removal of the inner rail;



- 1-4. Push the latch 'a' in the guide rail in the direction of the arrow; 1-5. At the same time, push the middle rail into the slide rail; 1-6. Complete step 1.

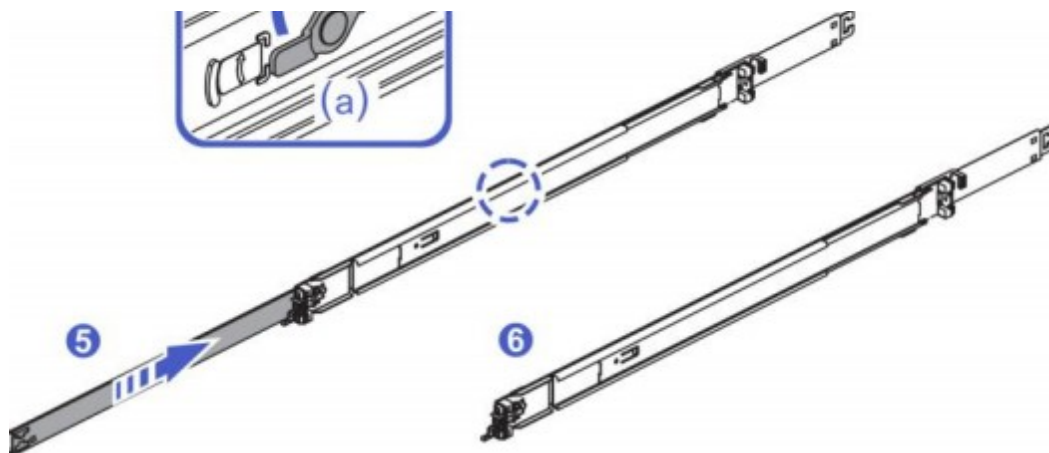

Step 2. Install the inner rails onto the chassis (the installation method for the left and right inner rails is the same).

2-1. Align the positioning holes ①-④ on the inner rail with one side of the chassis. 4

Use the mounting pins to install the inner rails onto the chassis as shown in the diagram. You should hear a click when the installation is complete. Ensure proper installation;

2-2. In chassis a Place the M4x4 in the attachment. Screws into position a of the chassis. Step 2 is complet

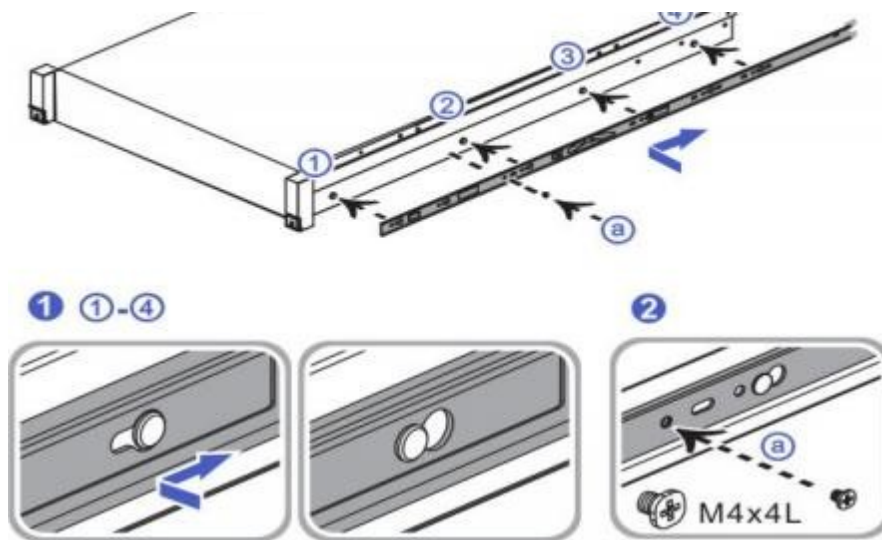

When removing the inner rail from the chassis, you need to unlock the clips in the inner rail as shown in the picture:



Step 3. Install the guide rails into the rack (the left and right guide rails are symmetrical, please repeat the installation).

3-1. Push the rear latch of the guide rail according to the arrow indication, align the guide rail with the frame hole, and install the guide rail into the frame; 3-2. Once you hear a click when you insert the guide rail into the rear end of the frame, the rear end installation of the guide rail is complete.

3-3. Push the front hook of the guide rail according to the arrow indication, align the guide rail with the frame hole, and install the guide rail into the frame; 3-4. After you hear a click when you install the guide rail into the front of the frame, you have completed step 3.

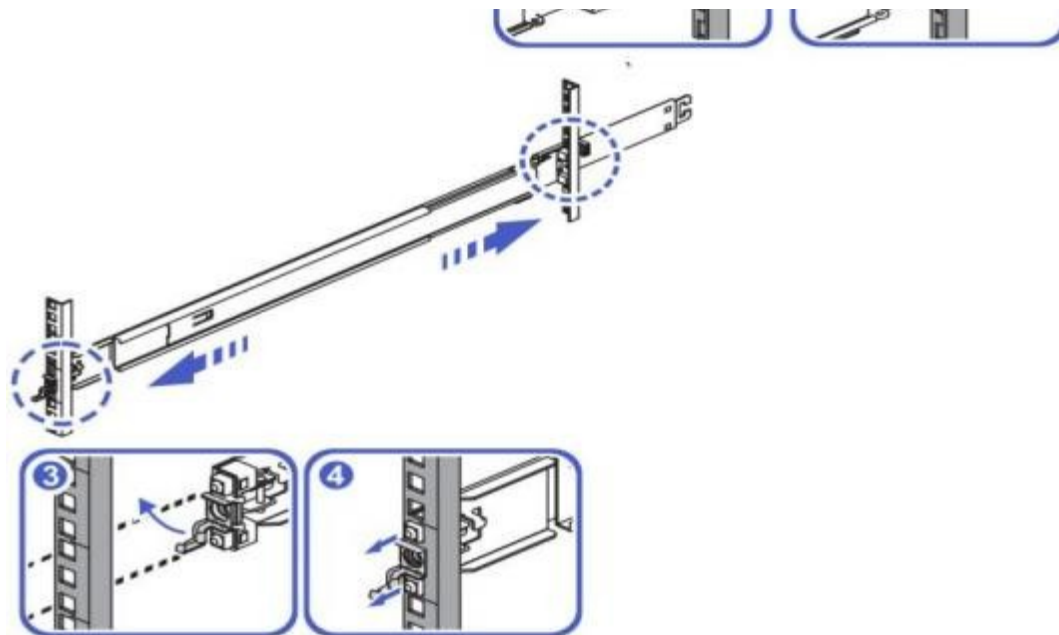

When removing the guide rail from the rack, the clips in the guide rail need to be unlocked as shown in the figure:

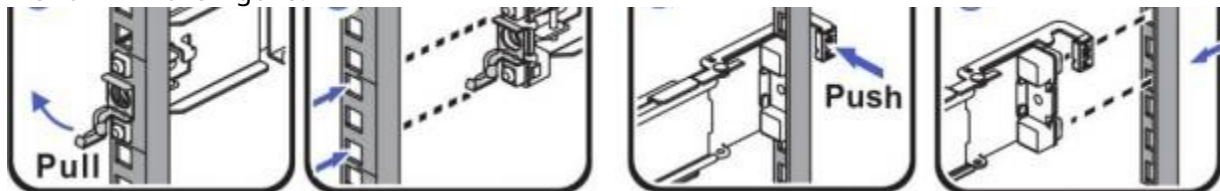

step 4. Install the server in the rack.

4-1. Pull out the two side rails installed in the frame. You will hear a click and the rails will stop.

4-2. Lift the server and align the inner rail with the middle rail. Push the server into the rack in the direction of the arrow, ensuring that the inner rail is smoothly inserted into the middle rail. 4-3. After pushing the server into the middle track, you can hear a click and then it stops.

4-4. Move the blue button in the direction of the arrow, and push the server into the rack while holding down the button;

4-5. Pry open the front ear loops on both sides. Tighten the screws with a screwdriver to complete the steps. 4.

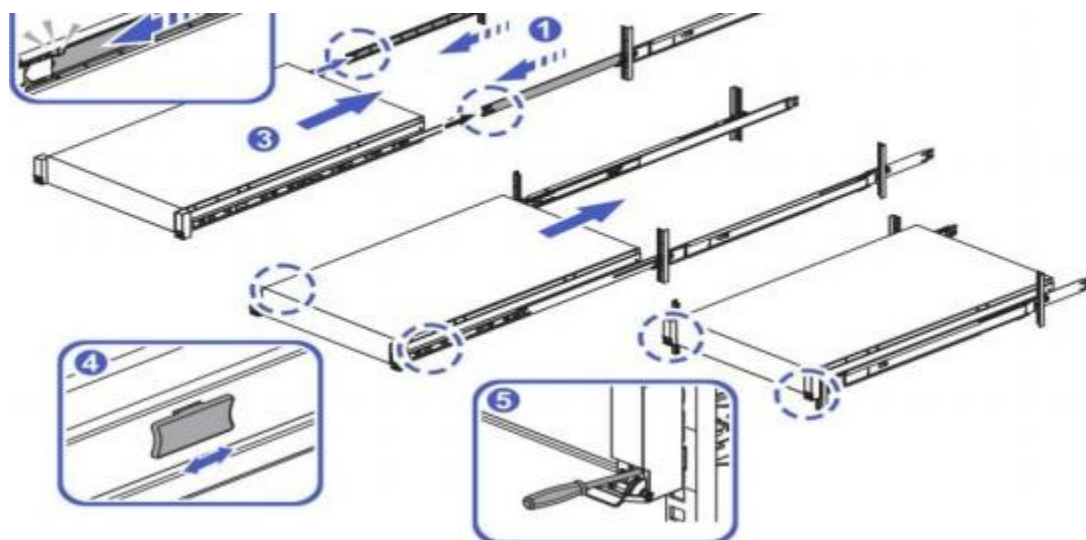

To remove the server from the rack, you need to unlock the screws on both sides and the white button. As shown in the figure :

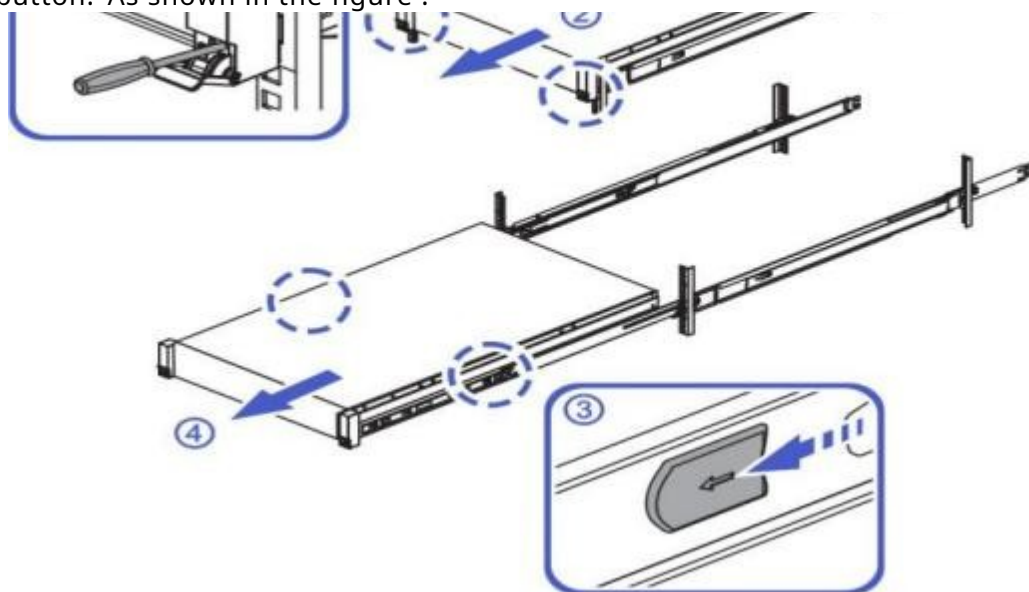

## 6. Operating Precautions and Troubleshooting

### 6.1 Operating Precautions

- RDIMM 1 DPC most high support 6400 MT /s , RDIMM 2 DPC most High support for 5200 MT /s; Using 6400MT/s The following memory rates contain 2DPC During configuration, the memory speed will drop to 4800MT/s or below;
- The motherboard's M.2 slot is a PCIe 5.0 x4 bandwidth.
- IO1/2/3/4 Riser When connecting a network card to the top slot, there may be interference with the chassis cover when unplugging the network cable or fiber optic cable. It is not recommended to connect the network card to the Riser. Topmost slot;
- The network indicator light on the ear hook will only illuminate when an OCP network card is installed and a network connection is established.
- SNR-LS-G6 The server does not support PCH, and the motherboard does not have onboard SATA interface;
- The memory of the SNR-LS-G6 server must be installed strictly in accordance with the POR rules. Disabling POR when the memory is fully connected will trigger a memory alarm.
- SNR-LS-G6 The server defaults to a power-on policy, meaning it needs to wait for a period of time after power-on before it can be turned on.
- The power consumption cap is in the advanced feature version, which can only limit the CPU. Power consumption is not limited by other devices such as GPUs and fans;
- The ambient temperature curve starts recording data only after the version is burned, and is recorded once every hour.
- There are many types of memory exceptions. The BMC unified alarm platform cannot cover all types of memory errors, and there may be instances where the memory alarm light is on , but there are no abnormalities on the BMC.
- IPMItool SOL Sol needs to be added activate usesolkeepalive Stay online;
- BMC web RAID/SAS Management needs to remove the card 's OOB ( Out of Hour) The mode is set to PCIe (currently all other items are I2C);
- IPMI permissions and BMC User roles and permissions are separate. The command to check IPMI permissions is: ipmitool -H \*.\*.\*.\* -I lanplus -U <username> -P <Password> user list View Chanel Priv Limit;
- BMC IPMI not supported Command to switch BIOS chip;
- FRU There are length requirements for each field to be burned. Please burn the data according to the requirements. The webpage does not limit the length of the burned content; the requirements are only textual.
- Discrete sensors do not support clicking to view details;
- VNC The service and KVM are mutually exclusive and cannot be started simultaneously.
- In BIOS setup The following describes how to hot-swap the hard drive, BMC. It does not record hard drive insertion/removal logs;
- because Due to limitations of the BMC's hard drive insertion and removal logging mechanism, it is not advisable to quickly insert and remove multiple hard drives simultaneously, otherwise some insertion and removal logs may not be recorded in a timely manner.
- BMC WEB Interface GPU Device information, GPU Power consumption display requires driver installation in the OS. For NVIDIA GPU devices , the command `nvidia-smi-pm1` is required. Set the GPU card to persistent mode. The corresponding GPU Power consumption can then be obtained normally .
- BHS Platform BIOS Legacy is not supported Mode, UEFI only model;
- NVIDIA table noodle flat tower core piece GPU No Windows Server 2019/2022 drive , Place To make use Windows 10/11 Version is sufficient;
- BIOS Setup The supported language is English; Chinese is not supported .
- Direct connection to backplane to 9560 RAID card set After setting the disk to offline status, the fault light on the hard drive will not illuminate. The same operation will illuminate the light on the expander back panel.
- NVMe The disk needs to be opened. VMD With Hotplug Only then can lighting and hot-plugging be performed;
- NVMe The recommended hot-swap interval is 20 seconds. seconds or more;
- NVMe drives Enable in Non - VMD mode Hotplugging allows for hot-swapping, but OS has Hardware error and AER Error message BMC There are relevant error logs;

- SATAIB-M22R-1VER.A Hard drive LED activation is not supported; BMC is not supported. Display hard drive information;
- SATAIB-M22R-1 VER.A Incompatible VMware ESXi 8.0;
- Different GPU models They cannot be installed on the same server simultaneously; GPU speed adjustment will only randomly match one of them. One model;
- Before installing the OS, it is recommended to format the disk to be installed, otherwise there may be situations where the installation cannot proceed normally due to other data on the disk.
- Using IPMI First-time burning of FRU by the tool The file will contain " bad" header The " CHECKSUM " message will not appear in subsequent updates ;
- Some features require enabling advanced features in the BMC to function, such as power firmware updates, power mode settings, power capping, and some Redfish features. and MIB Functions, etc.;
- The SOL log function requires an SD card to function.
- Install Windows Server 2019 The operating system needs to be modified in the BIOS. Options to limit CPU PA address arrive 46-bit; BIOS SETUP Next Enable Limit CPU PA to 46 bits ( SFR-CPU (Without this option, installation is not possible);
- Creating a RAID array on PCIe (M.2/U.2/E3.S) NVMe After that, CentOS 8.4 and Citrix Hypervisor 8.2, openEuler 22.03 Galaxy Kirin V10 UOS V20 RAID not recognized plate;
- Oracle Versions 9.0 and 8.7 are currently unavailable . Intel VROC Verified OS Not applicable to the list VMD create RAID;
- BHS The platform does not support Ubuntu 23.10 and the installation interface cannot be accessed.
- BIOS key needs to be manually imported. Secure Boot can only be enabled after that;
- BMC SSL The voucher needs to be generated and uploaded before it can be viewed;
- BMC Web The system detailed inventory will still display CPU, memory, and PCIe data even when the computer is off. information;
- BMC eth0 is a dedicated network port, eth1 is a shared network port, and eth2 is the DPU network port;

## 6.2 Heat dissipation limitation instructions

Front hard drive configuration	Fan configuration	Maximum operating temperature 30°C	Maximum operating temperature 35°C	Maximum operating temperature 40°C
12 x 3.5-inch hard drives	8056	<ul style="list-style-type: none"> <li>Supports all configurations</li> <li>Maximum support <b>250W</b> GPU , and CPU power consumption</li> </ul> <p>≤ <b>250 W</b></p>	<ul style="list-style-type: none"> <li>Supports all configurations</li> <li>Maximum support <b>150W</b> GPU , and CPU Power consumption</li> </ul> <p>≤ <b>250 W</b></p>	<ul style="list-style-type: none"> <li>Supports all configurations</li> <li>Maximum support <b>75W</b> GPU , and CPU power consumption</li> </ul> <p>≤ <b>250 W</b></p>
8 x 3.5-inch hard drives	8056	<ul style="list-style-type: none"> <li>Supports all configurations</li> <li>Matching At a graphics card power of <b>450W</b> , CPU power consumption</li> </ul> <p>≤ <b>250 W</b></p> <ul style="list-style-type: none"> <li>When paired with a dual-width passive <b>350</b> GPU, CPU power...</li> </ul> <p>Power consumption ≤ <b>350 W</b></p>	<ul style="list-style-type: none"> <li>Supports all configurations</li> <li>When paired with a dual-width passive <b>350 W</b>GPU , CPU power</li> </ul> <p>Power consumption ≤ <b>300 W</b></p>	<ul style="list-style-type: none"> <li>Supports all configurations</li> <li>Maximum support <b>150W</b> GPU , and CPU power</li> </ul> <p>Power consumption ≤ <b>250 W</b></p>
24x2.5-inch hard drives	8056	<ul style="list-style-type: none"> <li>Supports all configurations</li> <li>Maximum support <b>250W</b> GPU , and CPU power consumption</li> </ul> <p>≤ <b>250 W</b></p>	<ul style="list-style-type: none"> <li>Supports all configurations</li> <li>Maximum support <b>150W</b> GPU , and CPU Power consumption</li> </ul> <p>≤ <b>250 W</b></p>	<ul style="list-style-type: none"> <li>Supports all configurations</li> <li>Maximum support <b>75W</b> GPU , and CPU power consumption</li> </ul> <p>≤ <b>250 W</b></p>

8x2.5 inch hard drive	8056	<ul style="list-style-type: none"> <li>• Supports all configurations</li> <li>• Matching At a graphics card power of <b>450W</b> , CPU power consumption</li> </ul> <p>≤ <b>250 W</b></p> <ul style="list-style-type: none"> <li>• W h e n paired with a dual-width passive <b>350</b> GPU, CPU power...</li> </ul> <p>Power consumption ≤ <b>350 W</b></p>	<ul style="list-style-type: none"> <li>• Supports all configurations</li> <li>• W h e n paired with a dual-width passive <b>350</b> WGPU , CPU power</li> </ul> <p>Power consumption ≤ <b>300 W</b></p>	<ul style="list-style-type: none"> <li>• Supports all configurations</li> <li>• Maximum support <b>150W</b> GPU , and CPU power</li> </ul> <p>Power consumption ≤ <b>250 W</b></p>
32xE3.S haddisk	8056	<ul style="list-style-type: none"> <li>• Supports all configurations</li> <li>• Maximum support <b>250W</b> GPU , and CPU power consumption</li> </ul> <p>≤ <b>250 W</b></p>	<ul style="list-style-type: none"> <li>• Supports all configurations</li> <li>• Maximum support <b>150W</b> GPU , and CPU Power consumption</li> </ul> <p>≤ <b>250 W</b></p>	<ul style="list-style-type: none"> <li>• Supports all configurations</li> <li>• Maximum support <b>75W</b> GPU , and CPU power consumption</li> </ul> <p>≤ <b>250 W</b></p>
16xE3.S haddisk	8056	<ul style="list-style-type: none"> <li>• Supports all configurations</li> <li>• Matching At a graphics card power of <b>450W</b> , CPU power consumption</li> </ul> <p>≤ <b>350 W</b></p> <ul style="list-style-type: none"> <li>• W h e n paired with a dual-width passive <b>350</b> GPU, CPU power...</li> </ul> <p>Power consumption ≤ <b>350 W</b></p>	<ul style="list-style-type: none"> <li>• Supports all configurations</li> <li>• Matching CPU power consumption ≤ <b>300W</b> when graphics card is <b>450W</b></li> <li>• W h e n paired with a dual-width passive <b>350</b> WGPU , CPU power</li> </ul> <p>Power consumption ≤ <b>300 W</b></p>	<ul style="list-style-type: none"> <li>• Supports all configurations</li> <li>• Maximum support <b>150W</b> GPU , and CPU power</li> </ul> <p>Power consumption ≤ <b>250 W</b></p>

## 6.3 Common troubleshooting

### 6.3.1 Common hardware failures

- Server Backend VGA cannot be displayed.

Fault description: After the server is powered on, The status indicator light shows that everything is normal. Rear VGA No output displayed;

Cause of the fault: Front VGA and rear When VGA is connected simultaneously 2 VGA Only 1 can be output. One, and front VGA priority;

Solution: Remove the front-mounted power supply. VGA , rear VGA will display normally;

- Operating system cannot start

Fault Description: RAID card configuration RAID After the operating system is installed, The operating system cannot boot;

Cause of the malfunction: The RAID card is not configured with the installation drive bay as the preferred boot drive.

Solution: Enter LSI In the RAID card management interface, the RAID card with the system installed will be... Set the hard drive as the preferred boot drive, and you can enter the system normally ;

- GPU card PCIe speed reduction

Fault Description: GPU In the OS , it appears as Gen 1 (2.5 GT /s);

Cause of the problem: The system may activate the GPU 's power-saving mode. After GPU loading It will automatically upgrade to SPEC rate;

Solution: This is normal. No solution needed;

- The server fault indicator light is red or flashing.

Fault description: The server fault indicator light is red or flashing;

Possible causes of the malfunction: There are four possible causes.

- Fan malfunction alarm
- PSU abnormal alarm
- Memory error alert
- Chassis opening error alarm

Solution: Follow these troubleshooting steps to diagnose the problem.

- If the fault indicator light is constantly red, you need to check if the memory is abnormal, if there is a high temperature alarm, if the hard drive is abnormal , or if there is any abnormal intrusion into the chassis.
- If the fault indicator light flashes red, you need to check if the fan is malfunctioning. PSU Whether in office Is there any abnormality in the PSU power cord connection ?

- Manually Offline via RAID Card After the hard drive, The hard drive warning light is not on

Fault description: The server uses a direct-attached hard drive backplane configuration. Using LSI 9560 RAID card connection, in BIOS Manual Offline in RAID Card Setup After the hard drive is turned off, the hard drive warning light does not illuminate.

Cause of the malfunction: The LSI 9560 RAID card is designed this way;

Solution: RAID The inherent limitations cannot be resolved.

- After the hard drive positioning light is turned on, the other status lights on the hard drive will be replaced.

Fault description: The hard drive's Locate indicator light is on. Behind the positioning light, Other rebuilds of this hard drive , failure Status lights will be replaced;

Cause of failure: This is due to the server's design, which uses hard drive Locate. The high-priority mechanism for the hard drive location light means that when the hard drive location light is on, other status lights are overridden, making it easier for users to locate abnormal hard drives.

Solution: This is normal. No solution needed;

