



SNR

Purley platform 2U two-way L-shaped server barebones



User manual

V1.0

Preface

This manual is the product technical manual of Purley 2U dual-channel cabinet server. It mainly introduces and explains the technical characteristics, system architecture, installation method, and basic operation of this product. Purley 2U dual-channel server is divided into 2U8 bays and 2U12 bays. This product has the characteristics of low energy consumption, flexible expansion, high reliability, easy management and easy deployment.

This manual is for reference research by professional system integrators and personal computer technicians. This product should only be installed and maintained by experienced technicians.

Manual structure

Chapter 1 Security Statement

This chapter describes some environmental conditions, precautions and instructions related to this product that need to be paid attention to when using this product.

Chapter 2 Product Introduction

This chapter provides the specifications of the main components of the system and describes the main features of each model of the Purley 2U dual cabinet server series.

Chapter 3 Installing System Components

This chapter describes the installation methods and main precautions of various main system components using Purley 2U dual-channel cabinet server.

Chapter 4 System cabinet Installation

This chapter describes the installation steps and precautions of using the rails provided with Purley 2U dual-channel cabinet server.

Chapter 5 BIOS parameter setting description

This chapter mainly introduces the parameter settings and main functions of the system BIOS.

Chapter 6 RAID Setting Instructions

This chapter mainly introduces how to set up RAID.

Chapter 7 IPMI Rapid Deployment

This chapter mainly describes how to quickly deploy IPMI.

Chapter 8 Product Technical Specifications

This chapter focuses on the main technical specifications of Purley 2U dual-socket cabinet server products.

Statement

Copyright statement

OOO "NAG" All rights reserved.

All information contained in this user manual, including but not limited to it, is protected by copyright law. Without the permission of OOO "NAG" (hereinafter referred to as "OOO "NAG""), no copying, copying, or excerpting is allowed., Re-issuance, or other use.

Disclaimer

OOO "NAG" provides this user manual "as is". Within the scope of the law, it does not provide any express or implied guarantees and guarantees, including but not limited to commercial marketability, applicability for specific purposes, non-infringement of the rights of any other person, and any The guarantee of using this user manual or the inability to use this user manual, and OOO "NAG" does not provide guarantees and guarantees for the accuracy or reliability of the results obtained from using this user manual or any information obtained through this user manual.

Due to product version upgrades or other reasons, the contents of this user manual will be updated from time to time. Unless otherwise agreed, this user manual is only used as a guide, and the user shall bear all risks of using this user manual.

Trademark statement

SNR is a trademark of OOO "NAG"

Intel and Xeon are trademarks of Intel Corporation in the United States and other countries. Microsoft and Windows are trademarks of companies in the Microsoft group.

Linux is a registered trademark of Linus Torvalds.

Aspeed is a trademark of Xinhua Technology.

The ownership of other trademarks belongs to their respective owners.

Product name: Purley platform 2U dual-channel L-shaped server barebone

system manual version: V1.0

Publication date: June 2020

Glossary:

Noun	Paraphrase
Intel Xeon Scalable Processors	Intel Xeon Scalable Processor
Platinum efficiency power supply	Platinum certified power supply is "80 PLUS Platinum" standard, that is, the conversion rate of 20% load is above 90%, the conversion rate of 50% load is above 94%, and the conversion rate is 100%. Rate above 91%
M.2	M.2 interface is a new generation interface standard tailored for Ultrabook. It is a new interface specification introduced by Intel to replace mSATA
C621/C622	Intel Chipset
RJ45	Common name for standard 8-bit modular interface
AST2500	Aspeed BMC chip
Socket P	One of the Intel processor interface types
-F CPU	Refers to CPUs supporting Intel Omni-Path Host Fabric interface, Omni-Path High-speed optical cable interconnection technology, which can support up to 100Gbps end-to-end interconnection
8038 fan	Fan with size 80x80x38mm
LGA3647	The full name Land Grid Array, grid array package, LGA3647 represents 3647 Contacts
CR2032	It is a 3V CR2032 lithium manganese battery, shaped like a button, referred to as button battery or lithium manganese button battery
RS-232	One of the communication interfaces on the computer is the asynchronous transmission standard interface, called COM port
Jtag	Joint Test Action Group, a joint test working group, mainly used for internal chip testing
NC Pin	Empty pin
XDP	Extend Debug Port, Intel CPU debugging interface

Abbreviations

Explain the abbreviations used in this article, and provide the full English name, as shown in the following table:

Abbreviations	original
PCH	Platform Controller Hub
GbE	Gigabit Ethernet
BMC	Baseboard Management Controller
IPMI	Intelligent Platform Management Interface
CPU	Central Processing Unit
SATA	Serial Advanced Technology Attachment
SAS	Serial Attached SCSI
sSATA	secondary SATA
LAN	Local Area Network
VGA	Video Graphics Array
MB	Mother Board
MIB	Motherboard Interface Board
BP	Backplane
PDB	Power Distribution Board
FIB	Fan Interface Board
PCIE	Peripheral Component Interconnect Express
USB	Universal Serial Bus
FW	Firmware
TPM	Trusted Platform Module
IO	Input / Output
BIOS	Basic Input-Output System
CMOS	Complementary Metal Oxide
ME	Management Engine
DDR4	Double Data Rate 4 SDRAM
DIMM	Dual-Inline-Memory-Modules
RDIMM	Registered DIMM
LRDIMM	Load-Reduced DIMM
AEP	Apache Pass
MEZZ CONN	Mezzanine Connector
KVM	Keyboard Video Mouse
CPLD	Complex Programmable Logic Device
ECC	Error Correcting Code
CFM	Cubic Feet Per Minute
RPM	Revolution Per Minute

Symbol convention:

 Note: It is used to transmit equipment or environmental safety warning messages. If not avoided, it may cause equipment replacement, data loss, equipment performance degradation or other unpredictable results.

 Warning: Used to warn of potentially dangerous situations, which, if unavoidable, may cause death or serious personal injury.

 Red arrow: means pointing to a certain position.

 Blue arrow: represents the action of pulling out or inserting downward or tilting.

 Hollow arrow: represents the next action or result.

 Dark blue rotating arrow 1: represents the action of turning the screw clockwise or pulling out.

 Dark blue rotating arrow 2: represents the action of turning the screw counterclockwise or buckling inward.

Contents

Chapter 1 Security Statement.....	15
1.1 General safety matters.....	15
1.2 Product name and content identification table of toxic and hazardous substances or elements ...	17
1.3 Warning notice.....	19
1.4 Climate and environmental requirements.....	20
1.5 Other important description.....	21
Chapter 2 Product Introduction.....	22
2.1 system introduction.....	22
2.2 System Configuration.....	22
2.2.1 System parameters.....	23
2.2.2 system structure.....	24
2.3 System model specification introduction.....	27
2.4 System component introduction.....	31
2.4.1 Front panel components.....	31
2.4.2 Rear panel components.....	35
2.4.3 Motherboard components.....	38
2.4.4 Hard disk backplane assembly.....	39
2.4.5DIMM slot location.....	50
2.4.6 Hard disk label.....	51
2.4.7 Hard Disk Indicator.....	51
2.4.8 System fan.....	52
Chapter 3 Installing System Components.....	53
3.1 CPU installation.....	53
3.2 Radiator installation.....	55
3.3 Memory installation.....	56
3.4 Hard disk installation.....	58
3.5 Front hard disk backplane installation.....	61
3.6 M.2 SSD installation.....	63
3.7 PCI-E module installation.....	66
3.8 Rear hard disk module backplane installation.....	67
3.9 Rear hard disk module installation.....	68
3.10 Power supply module installation.....	70
3.11 PCI-E expansion card installation.....	71
3.12 Fan module installation.....	73
3.13 Installation of air duct.....	74
3.14 Installation of the upper cover of the chassis.....	77
Chapter 4 System cabinet Installation.....	78
4.1 Rail installation.....	78
4.2 Install the outer rail to cabinet.....	79
4.3 Install server to cabinet.....	81
Chapter 5 BIOS parameter setting description.....	83
5.1 Enter the BIOS Setup interface.....	83
5.2 Setup menu parameter description.....	83
5.2.1 Navigation key description.....	83
5.2.2 Main menu description.....	84
5.2.3 Advanced menu description.....	86
5.2.4 Trusted Computing.....	88
5.2.5 Serial Port Console Redirection.....	89
5.2.6 Console Redirection Settings.....	90
5.2.7 SIO Configuration.....	92
5.2.8 [*Active*] Serial Port.....	93

5.2.9	Option ROM Dispatch Policy	94
5.2.10	PCI Subsystem Settings	96
5.2.11	CSM Configuration	97
5.2.12	NVMe Configuration	98
5.2.13	Network Stack Configuration	99
5.2.14	iSCSI Configuration	101
5.2.15	Platform Configuration menu	102
5.2.16	PCH SATA Configuration	103
5.2.17	PCH sSATA Configuration.....	105
5.2.18	USB Configuration.....	106
5.2.19	Miscellaneous Configuration.....	107
5.2.20	Server ME Configuration	108
5.2.21	Runtime Error Logging.....	109
5.2.22	Socket Configuration menu.....	110
5.2.23	Processor Configuration	111
5.2.24	Common RefCode Configuration.....	115
5.2.25	UPI Configuration	116
5.2.26	Memory Configuration	119
5.2.27	Memory Topology.....	122
5.2.28	Memory Map.....	123
5.2.29	Memory RAS Configuration	125
5.2.30	IIO Configuration	127
5.2.31	Advanced Power Management Configuration.....	129
5.2.32	CPU P State Control.....	130
5.2.33	Hardware PM State Control.....	131
5.2.34	CPU C State Control.....	132
5.2.35	Package C State Control	134
5.2.36	CPU-Advanced PM Tuning.....	135
5.2.37	Energy Perf BIAS	136
5.2.38	Server Mgmt menu	137
5.2.39	System Event Log menu.....	139
5.2.40	BMC network configuration menu.....	141
5.2.41	View System Event Log menu.....	144
5.2.42	BMC User Setting.....	145
5.2.43	Add User	146
5.2.44	Delete User	147
5.2.45	Change User Setting	148
5.2.46	Security menu.....	149
5.2.47	Boot menu	150
5.2.48	Save & Exit menu	152
5.3	User action reminder.....	153
Chapter 6	RAID Setting Instructions	154
6.1	PCH group RAID.....	154
6.1.1	Configure RAID in UEFI boot mode.....	154
6.1.2	Configure RAID in Legacy Boot Mode	164
6.2	LSI 9361-8i Group RAID	175
6.2.1	Configure RAID in UEFI boot mode.....	175

6.2.2Configure RAID in Legacy Boot Mode	228
Chapter 7 IPMI Rapid Deployment	251
7.1 Rapid deployment of IPMI process.....	251
7.1.1 Make sure the motherboard supports IPMI function.....	251
7.1.2 Enter BIOS to set up IPMI function	252
7.1.3IPMI interface configuration Static mode	255
7.1.4IPMI configuration Java SOL.....	256
7.2 IPMI function quick start instructions	257
7.2.1 Enter the operation interface.....	257
7.2.2 Default username and password	259
7.2.3IPMI management system content	259
7.2.4Introduction to KVM remote management	262
7.2.5KVM page introduction	263
7.2.6 Remote control quick operation	264
7.2.7Introduction to SOL	265
7.3 Other ways to connect to IPMI	267
7.3.1IPMI driver.....	267
7.3.2IPMI tools and other open source software.....	267
Chapter 8 Product Technical Specifications.....	268
8.1 Technical specifications	268

Chapter 1 Security Statement

1.1 General safety matters

To prevent the risk of major personal and property losses, please follow the following recommendations.

Please do not open the system cover by yourself, and should be operated by professionally trained maintenance technicians. There may be high voltage or electric shock on the triangular mark with lightning symbol, please do not touch it.

Remember: Disconnect all cables before performing maintenance. (There may be more than one cable) It is strictly forbidden to perform live operations such as starting the machine before the cover is closed.

When it is necessary to open the cover, please wait for the internal equipment to cool down before performing it, otherwise it is easy to burn you.

Do not use this device in a humid environment.

If an extension cable needs to be used, please use a three-wire cable and make sure it is properly grounded.

Ensure that the computer is well grounded. Different grounding methods can be used, but it must be actually connected to the ground. If you are not sure whether the grounding protection has been secured, please contact the corresponding agency or electrician for confirmation. If you need twisting table cable wiring, please contact OOO "NAG". to provide suggestions.

Please use a three-core power cord and socket with grounding protection. Improper grounding may cause leakage, burns, explosions and even personal injury.

Please make sure that the power socket and the power interface can be in close contact, loose contact may cause a fire hazard.

Please use your computer under 220V AC voltage. Working at an improper voltage will cause electric shock, fire and computer damage.

The computer is required to be well ventilated and far away from heat and fire sources, and do not block the cooling fan, otherwise the computer may cause smoke, fire or other dangers due to overheating.

If you smell or see smoke from your computer, please turn off the computer immediately and unplug the power cord.

It is required to be able to easily plug and unplug the power cord from the power source and the power socket. Please keep the power cord and plug clean and intact, otherwise there may be a risk of electric shock or fire.

Note: If the battery is replaced incorrectly, there is a danger of explosion. Only use the same or equivalent type of replacement recommended by the manufacturer. The used battery will pollute the environment. Please follow the relevant instructions for the replacement of the old battery.

Keep the computer away from electromagnetic fields.

Keep away from electronic noise caused by high-frequency safety equipment such as air-conditioning, large fans, large motors, radio and television transmission towers.

Please do not plug or unplug the backplane cable or move the computer while the computer is running, otherwise it may cause the computer to crash or damage the components.

Please try to avoid frequent restarting or switching on and off to extend the life of the computer.

Please keep the environment clean and avoid dust. The working environment temperature of the equipment is 10°C~35°C, and the humidity is 35%~80%.

Users are requested to back up important data in time. OOO "NAG" is not responsible for data loss caused by any circumstances.

The optical drive used in this product is a Class 1 laser device.



Figure 1-1

1.2 Product name and content identification table of toxic and hazardous substances or elements

Within the 10-year environmental protection use period, the toxic and hazardous substances or elements contained in the product will not leak or mutate under normal use conditions, and the use of electronic information products by users of electronic information products will not cause serious pollution to the environment or affect them. Cause serious damage to person and property.

Table 1- 1

Part Name	Harmful Substance					
	Lead (Pb)	Mercury (Hg)	Cadmium (Cd)	Hexavalent Chromium (Cr VI)	Polybrominated biphenyls (PBB)	Polybrominated Diphenyl Ether (PBDE)
Media reading/storage device (CD, etc.)	X	O	O	O	O	O
Power supply/power adapter	X	O	O	O	O	O
Power cable	X	O	O	O	O	O
Pointing device (mouse, etc.)	X	O	O	O	O	O
Keyboard	X	O	O	O	O	O
UPS	X	O	O	O	O	O
Complete cabinet/rail products	X	X	O	O	O	O

Table 1- 2

○ It means that the content of this toxic and hazardous substance in all homogeneous materials of this part is below the limit requirement stipulated in GB/T26572-2011 "Limit Requirements for Restricted Substances in Electronic and Electrical Products".

✗ Indicates that the content of the toxic and hazardous substance in at least one of the homogeneous materials of the part exceeds the limit requirement specified in GB/T26572-2011 "Limited Requirements for Restricted Substances in Electronic and Electrical Products". But it complies with the EU RoHS directive (including its exemption clauses).

Note: This table shows the status of toxic and hazardous substances contained in all components that may be used in SNR server, storage and workstation products. Customers can check the status of toxic and hazardous substances contained in each component of the purchased product based on this table.

1.3 Warning notice

This product complies with EMC Class A standards.

1.4 Climate and environmental requirements

- The best working temperature of the equipment is 10°C—35°C; the highest indoor ambient temperature of the equipment is 40°C.
- System battery
3 V CR2032 lithium battery.

Note: Some configurations have been tested for performance at 45°C temperature and 90% (29°C maximum dew point) humidity.

Temperature	
Operating temperature	10 °C to 35 °C (50 °F to 95 °F), the maximum temperature gradient is Hour 10 °C
Continuous operating temperature range (under the sea (At 950 meters or 3117 feet)	In the case of equipment without direct light, 10 °C to 35 °C (50 °F to 95 °F) .
Storage temperature range	--40°C to 65°C (-40°F to 149°F)
Humidity	
Storage	When the maximum dew point is 33 °C (91 °F), the relative humidity is 5% to 95%. The air must never condense.
Continuous operating humidity percentage range	When the maximum dew point is 26 °C (78.8 °F), the relative humidity is 10% to 80%.

Table 1- 3

- If the computer use environment has poor or no lightning protection facilities, please shut down during a thunderstorm and unplug the power cord, network cable, telephone line, etc. connected to the computer.
- Please use genuine operating system and software, and configure it correctly. OOO "NAG". assumes no maintenance responsibility for server failures caused by operating systems and software.
- Please do not disassemble the case and increase or decrease the server hardware configuration by yourself. OOO "NAG". is not responsible for the hardware and data damage caused by this.
- When the server fails, please first check the "Troubleshooting" section of this manual to determine and eliminate common failures. If you are not sure of the cause of the failure, please contact the technical support department of OOO "NAG". for help.
- Choosing a suitable environment for the computer is helpful for the stable operation of the computer and can extend the service life of the computer.

OOO "NAG" reserves the right of final interpretation of the above terms

1.5 Other important description

"If the equipment is marked with a logo, it means that the equipment with the logo is only fully designed and evaluated at an altitude of 2000m. Therefore, it is only suitable for safe use below 2000m and in the sea.



When used at a distance of more than 2000m, there may be safety hazards."



"If the device is marked with this logo, it means that the device with the logo is only designed and evaluated for safety in non-tropical climatic conditions. Therefore, it is only suitable for safe use under non-tropical climatic conditions.

When used in tropical climates, there may be safety hazards."

Chapter 2 Product Introduction

2.1 system introduction

Purley 2U dual-channel L-type server is a new generation of 2U dual-channel cabinet server with a wide range of uses that OOO "NAG" has launched for the needs of the Internet, IDC (Internet Data Center), cloud computing, enterprise market and telecom business applications. It is suitable for IT core business, cloud computing virtualization, high-performance computing, distributed storage, big data processing, enterprise or telecom business applications and other complex workloads. The server has the advantages of low energy consumption, strong scalability, high reliability, easy management, and easy deployment.

2.2 System Configuration

Nebulas 2 Purley 2U dual-channel L-shaped server products include 2U8 (3.5" hard disk) disk bays, 2U12 (3.5" hard disk) The two models have the same specifications except for the hard disk connection method and the maximum number of compatible hard disks.

2.2.1 System parameters

Features	Technical specifications
Series models	2U8 (3.5" hard disk) bay, 2U12 (3.5" hard disk) bay
Size	2U cabinet type, 748*433.4*87.6mm
processor	1st and 2nd generation Intel Xeon Scalable processors Maximum support 205W
RAM	Support DDR4 LRDIMM/RDIMM/NV-DIMM ECC memory Memory frequency support 2133/2400/2666/2933MHz A single CPU supports 6 DDR4 Channels, with 2 slots per Channel, and a total of 24 DDR4 slots for CPU0/CPU1 Support a single capacity of 8GB, 16GB, 32GB, 64GB, 128G
Storage controller	Internal storage: 2 SATA ports (7Pin), 2 PCIe 3.0 X2 M.2 Interface, 3 minisas 8643 interfaces, 2 slimline x8 interfaces
Driver	The front panel supports up to 8/12/hot-plug 3.5/2.5-inch SAS/SATA (HDD/SSD) The rear supports 4*2.5" and 4*3.5" hard disks or 8*2.5"
Power supply	Platinum 550W, 800W, 1200W, 1600W hot-swappable redundant power Source (adapted according to actual power)
External port and PCIE	Front port: 1 VGA; 2 USB3.0 Rear: 1 VGA, 1 DB-9COM port, 2 USB3.0, 1 RJ45 Gigabit management network port, 2 Gigabit/10 Gigabit RJ45 network ports PCIE expansion: supports up to 11 PCIe3.0 slots
System fan	N+1 hot-swappable redundant fans
LAN	2 Gigabit/10 Gigabit RJ45 network ports
Safety	Support TPM module Chassis opening intrusion detection
Management	The onboard iBMC management module supports IPMI, SOL, KVM Over IP, Management features such as virtual media

Table 1- 4

2.2.2 System structure

The dual-socket L-shaped server uses the Intel Purley platform with Intel Xeon scalable processors; supports DDR4 LRDIMM/RDIMM/NV-DIMM ECC server memory, and the memory frequency supports 2133/2400/2666/2933MHz; a single CPU supports 6 Two channels, each channel supports 2 DIMMs; two CPUs support a total of 24 DDR4 slots; supports a single capacity of 8GB, 16GB, 32GB, 64GB, 128GB.

The main board features are as follows:

- The CPU adopts the first- and second-generation Intel Xeon scalable processors, LGA3647 socket, TDP power consumption 205W;
- Each CPU supports six-channel DDR4, each channel has 2 DIMM strips, RDIMM/LRDIMM. And each CPU supports a maximum capacity of 1.5TB;
- DDR4 type: DDR4-2133/2400/2666/2933ECC-RDI, ECC-LRDIMM;
- There are 3 PCIE RISER slots on the board, of which: RISER1 24 PCIE LANES are all from CPU0, 24 PCIE LANES of Riser2, of which 8 PCIE LANES are from CPU0, 16 PCIE LANES are from CPU1, 16 PCIE LANES of Riser3 Also from CPU1;
- The G3DCL-B motherboard provides 2 M.2 Key M SSD slots, supports 2280 size, and only supports PCIe X2 signals;
- Two Gigabit Ethernet ports are integrated on the motherboard, using 88E1512 chip, from PCH;
- Southbridge PCH uses INTEL LEWISBURG C621/C622 series chipset;
- PCH leads to 14 SATA Ports, the highest rate: 6Gb/s, compatible with SATA 1.5Gb/s, 3.0Gb/s; SATA Controller provides 8 SATA PORTs, and SSATA provides 6 SATA PORTs, of which SATA PORT 8 PORT, according to Two SFF8643 connectors are introduced in order, and the first four PORTs of SSATA are introduced into one SFF8643 connector, and the latter two PORTs are introduced into the 7PIN SATA connector for access to SATA DOM and DVD;
- The BMC chip in this single board uses ASPEED's AST2500 control chip to do IPMI remote management. VGA output port, dedicated Gigabit RJ45 management network port, and connected to PCH through RMII/NCSI.

The main board block diagram of the system architecture is as follows:

G3DCL-B (Nebula2) Block Diagram

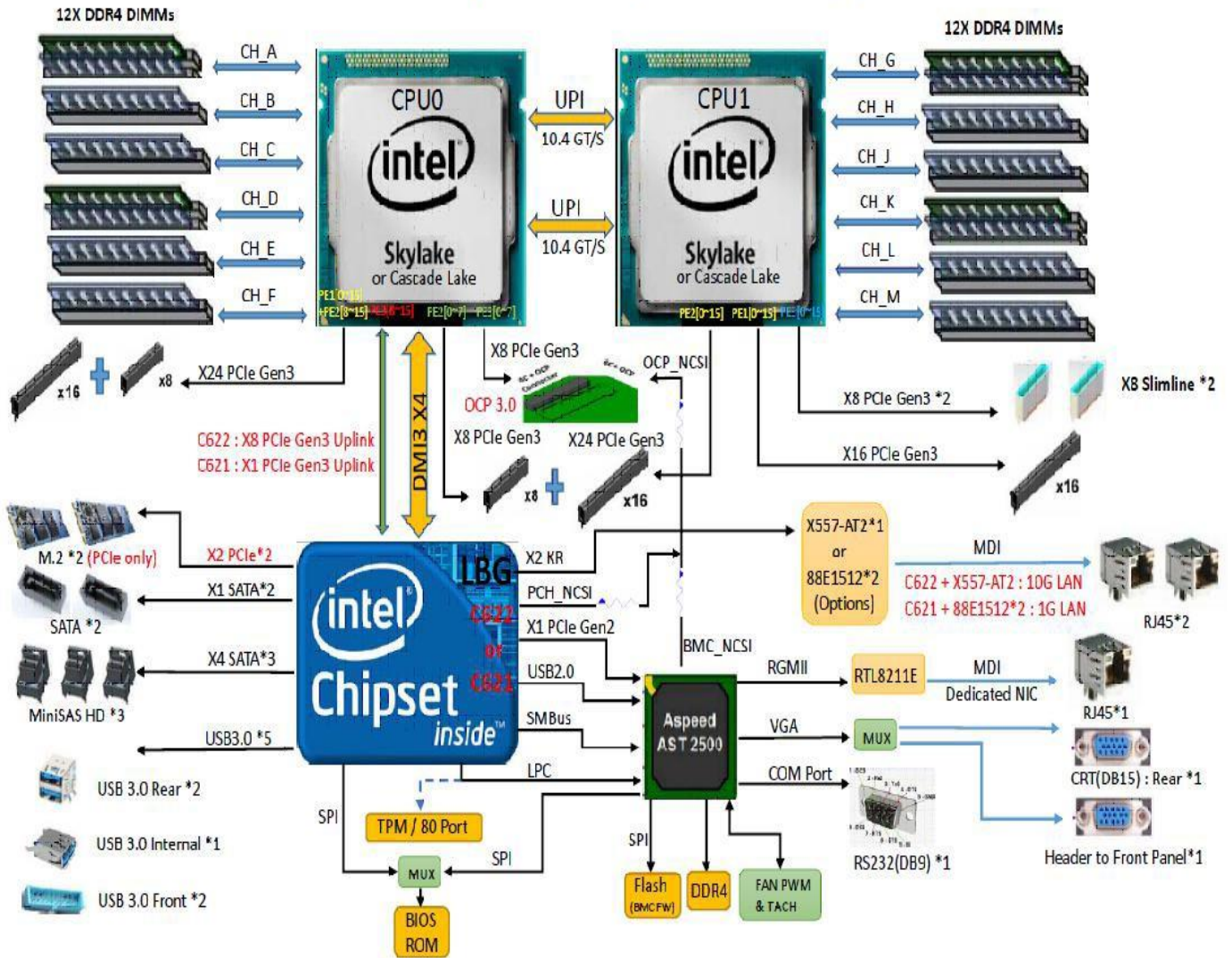

Figure 2- 1

2.3 System model specification introduction

- 2U8 disk bay 3.5-inch disk model



Figure 2- 2

Product name	2U8 (3.5" hard disk)
Processor	Support 1 or 2 Intel Xeon Scalable series processors Maximum support 205W
Motherboard model	G3DCL-B/G3DCL-TB
Chipset	Intel C621/C622 series server dedicated chipset
RAM (system)	Support DDR4 LRDIMM/RDIMM/NV-DIMM ECC memory Memory frequency support 2133/2400/2666/2933MHz A single CPU supports 6 DDR4 Channels, each Channel has 2 slots, CPU0/CPU1 totals 24 DDR4 slots Support a single capacity of 8GB, 16GB, 32GB, 64GB, 128G
Expansion Card	1.(Left) PCI-Express 3.0 X24 slot comes from CPU0; 2.(Middle) PCI-Express 3.0 X24 slot comes from CPU0 / CPU1; 3.(Right) PCI-Express 3.0 X16 slot comes from CPU1;
Hard disk	Supports up to 8 front 3.5-inch/2.5-inch SAS/SATA (HDD/SSD) The rear can support 4 2.5-inch SAS/SATA (HDD/SSD), 4 rear 3.5/2.5-inch SAS/SATA (HDD/SSD) Onboard 3*8643 interface, 2*SATA DOM
Optical drive	Support 1 optical drive;
M.2 SSD	2 M.2 PCIE X2 (2280)
LAN	Onboard 2 Gigabit RJ45 data network ports (optional 2 Gigabit RJ45 data Network port)
External port	Front port: VGA, 2 USB3.0 Rear: VGA, 2 USB3.0, 1 management network port, 2 RJ45 Data network port, 1 DB-9 COM port
Management	The onboard iBMC management module supports IPMI, SOL, KVM Over IP, Management features such as virtual media
System fan	4 8038 brand fans (optional 4 8056 brand fans)
Power supply	Standard platinum 550W, optional 800W, 1200W, 1600W hot-swappable redundant power supply (CRPS)
Dimensions	2U cabinet type, 748x433.4x87.6mm

Table 1- 5

- 2U12 disk bay 3.5-inch disk model



Figure 2- 3

Product name	2U12 (3.5" hard disk)
Processor	Support 1 or 2 Intel Xeon Scalable series processors, maximum support 205W
Motherboard model	G3DCL-B/G3DCL-TB
Chipset	Intel C621/C622 series server dedicated chipset
RAM (system)	Support DDR4 LRDIMM/RDIMM/NV-DIMM ECC memory Memory frequency support 2133/2400/2666/2933MHz A single CPU supports 6 DDR4 Channels, each Channel has 2 slots, CPU0/CPU1 totals 24 DDR4 slots Support a single capacity of 8GB, 16GB, 32GB, 64GB, 128G
Expansion Card	1.(Left) PCI-Express 3.0 X24 slot comes from CPU0; 2.(Middle) PCI-Express 3.0 X24 slot comes from CPU0 / CPU1; 3.(Right) PCI-Express 3.0 X16 slot comes from CPU1;
Hard disk	Support up to 12 front 3.5-inch/2.5-inch SAS/SATA (HDD/SSD) The rear can support 4 2.5-inch SAS/SATA (HDD/SSD) and 4 rear 3.5/2.5-inch SAS/SATA (HDD/SSD) Onboard 3*8643 interface, 2*SATA DOM
Optical drive	Support 1 optical drive;
M.2 SSD	2 M.2 PCIE X2 (2280)
LAN	Onboard 2 Gigabit RJ45 data network ports (optional 2 Gigabit RJ45 data network ports)
External port	Front port: VGA, 2 USB3.0 Rear: VGA, 2 USB3.0, 1 management network port, 2 RJ45 Data network port, 1 DB-9 COM port
Management	The onboard iBMC management module supports management features such as IPMI, SOL, KVM Over IP, and virtual media
System fan	4 8038 brand fans (optional 4 8056 brand fans)
Power supply	Standard platinum 550W, optional 800W, 1200W, 1600W hot-swappable redundant power supply (CRPS)
Dimensions	2U cabinet type, 748x433.4x87.6mm

Table 1- 6

2.4 System component introduction

2.4.1 Front panel components

- 2U8 disk bay 3.5-inch disk model

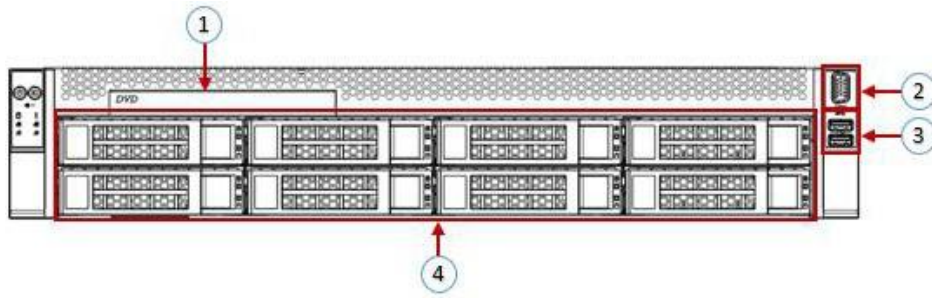

Figure 2- 4

Serial number	Name	Serial number	Name
1	Built-in DVD drive	3	USB3.0 interface
2	VGA interface	4	3.5-inch hard drive

Table 1- 7

- 2U12 disk bay 3.5-inch disk model

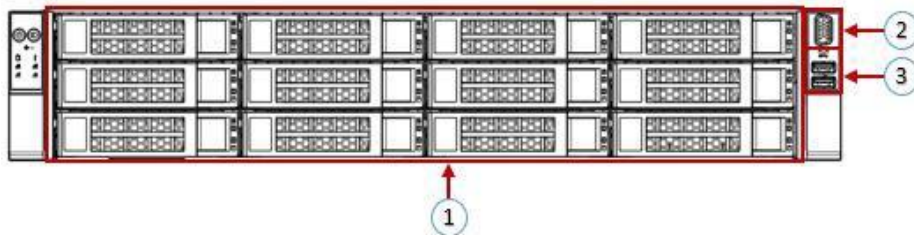

Figure 2- 5

Serial number	Name	Serial number	Name
1	Hard disk	3	USB3.0 interface
2	VGA interface		

Table 1- 8

- **Front panel interface description**

Name	Types of	Description
VGA interface	DB15	Used to connect a display terminal, such as a monitor or KVM.
USB interface	USB 3.0	Provide an outgoing USB interface, through which USB devices can be connected. note:When using an external USB device, please make sure that the USB device is in good condition, otherwise it may cause the server to work abnormal.

Table 1- 9

- **Description of front panel indicators and buttons**

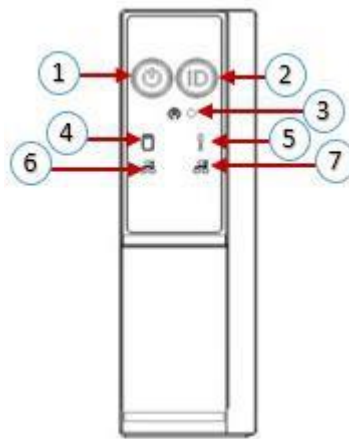

Figure 2- 6

Serial number	Indicator light/button	Serial number	Indicator light/button
1	Power switch button/indicator	5	System alarm indicator
2	UID button/indicator	6	Network port 1 connection status indicator
3	Reset button	7	Network port 2 connection status indicator
4	Hard Disk Indicator		

Table 1- 10







LED status description		
Logo	Indicator light/button	State description
	Power switch button/indicator	<p>Power indicator description: Green (steady light): indicates that the device has been powered on normally. Green (flashing): indicates that the device is in standby. Green off: The device is not powered on.</p> <p>Power button description: Short press this button in the boot state, the OS will shut down normally. Press and hold this button for 6 seconds in the power-on state to force the server to power off. Short press the button when it is to be powered on, you can Turn on.</p>
	UID button/indicator	<p>The UID button/indicator is used to conveniently locate the server to be operated. You can manually press the UID button or BMC command to remotely control the lamp to turn off or on.</p> <p>UID indicator description: Blue (steady light/flashing): indicates that the server is located. Off: The server is not located.</p> <p>UID button description: short press this button to Turn on/off the positioning light.</p>
	Reset button	Press to restart the server
	Hard Disk Indicator	Green light flashes: the hard disk is operating normally
	System alarm indicator	System alarm indicator. Including system alarm, fan alarm, power supply alarm, etc. IPMI management software view
	Network port connection status indicator	Corresponding to the Ethernet port indicator of the network card. Green (steady light): indicates that the network port is connected normally. Off: indicates that the network port is not in use or is faulty. Note: Corresponding to two 1GE network ports on the motherboard.
	Network port connection status indicator	Corresponding to the Ethernet port indicator of the network card. Green (steady light): indicates that the network port is connected normally. Off: indicates that the network port is not in use or is faulty. Note: Corresponding to two 1GE network ports on the motherboard.

Table 1- 11

2.4.2 Rear panel components

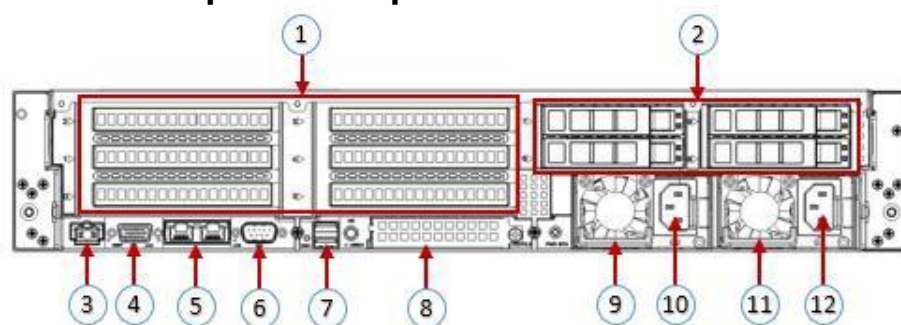

Figure 2- 7

Serial number	Name	Serial number	Name
1	Rise module	7	USB 3.0 interface
2	Hard Disk Module	8	OCP3.0 interface
3	Management network port	9	Power module 1
4	VGA interface	10	Power module 1 AC interface
5	RJ45 Gigabit Ethernet port	11	Power module 2
6	COM port	12	Power module 2 AC interface

Table 1- 12

◇ Description:

Both 1 and 2 can be equipped with rear hard disk modules or riser modules. This picture is for reference only, and the actual configuration shall prevail.

● Rear panel interface description

Name	Types of	Quantity	Description
VGA interface	DB15	1	Used to connect a display terminal, such as a monitor or KVM
Management network port	GE BASE-T	1	Provide an outgoing 1000Mbit/s Ethernet port. The server can be managed through this interface.
USB interface	USB 3.0	2	Provide an outgoing USB interface, through which USB devices can be connected. note: When using an external USB device, make sure that the USB device is in good condition, otherwise it may cause the server to malfunction. Make an exception.
RJ45 Gigabit Ethernet port	GEBASE-T	2	Server service network port.
Power module AC interface		1 or 2	You can choose the number of power supplies according to your actual needs, but you must ensure that the rated power of the power supply is large It is the rated power of the whole machine.
COM port		1	Serial communication port
OCP3.0 interface		1	Install OCP3.0 network card

Table 1- 13

● Description of indicators and buttons on the rear panel

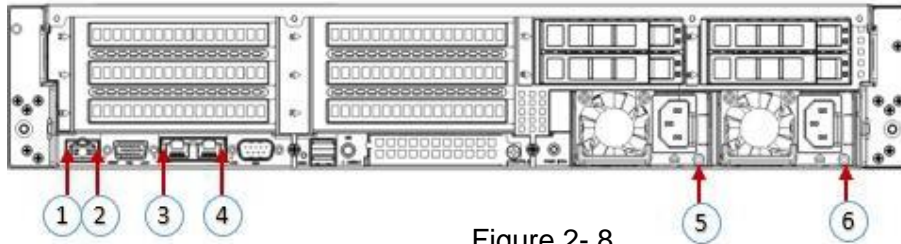

Figure 2- 8

Serial number	Name	Serial number	Name
1	Connection status indicator	4	Data transmission status indicator
2	Data transmission status indicator	5	Power module indicator
3	Connection status indicator	6	Power module indicator

Table 1- 14

Indicator light/button	State description
Power module indicator	Green (steady light): It indicates that the input and output are normal. Red (steady light): It means that the input is normal, power supply over-temperature protection, power supply output over-current/short circuit, output over-voltage, short-circuit protection, device failure (excluding all device failures) and other reasons cause no output. Green (1Hz/flashing): It indicates that the input is normal, and the power supply has turned off the output due to power-on or in-position; input overvoltage or undervoltage. Green (4Hz/flashing): indicates that the firmware is being upgraded online. Off: There is no AC power input.
Connection status indicator	Steady green: It means Gigabit Link. Long orange light: It means 100M Link. Extinguished: Ten trillion Link.
Data transmission status indicator Indicator light	Yellow (flashing): indicates that data is being transmitted. Off: No data is being transmitted.

Table 1- 15

2.4.3 Motherboard components

- All models share motherboard components, and the interface description is as follows

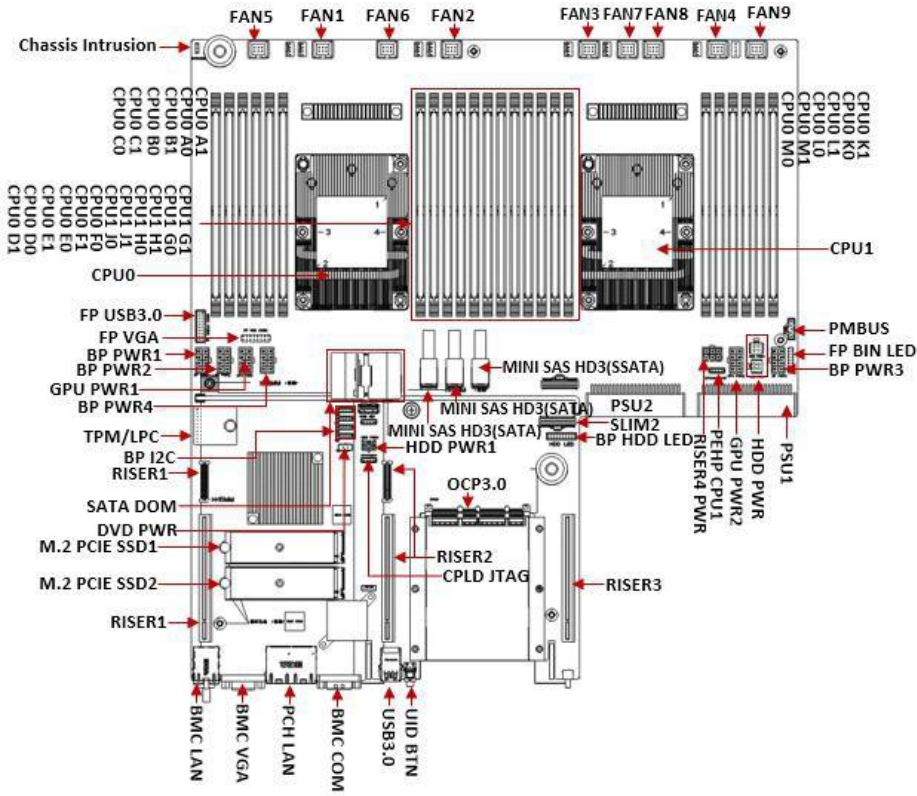

Figure 2- 9

2.4.4 Hard disk backplane assembly

- 2U12 expansion backplane as shown

TOP noodles

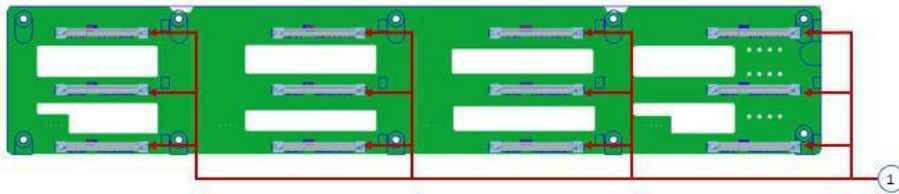

Figure 2- 10

Serial number	Description	Features
1	SAS/SATA hard disk connector	1. Maximum support 12G/b SAS hard disk; 2. Maximum support 6G/b SATA hard disk; 3. Supports hot swap of SAS/SATA hard disks.

Table 1- 16

Bottom surface

Serial number	Description	Features
1, 2, 3, 4	Temperature control fan socket	For 12G/b SAS or 6G/b SATA Number transmission.
5, 6, 7	Power connector	Backplane power transmission connector for 12V power supply Transmission.
8	EXPANDER chip	PM8043 SXP 24Sx12G 24-port 12G SAS Expander
9	MINI SAS HD high Fast connector	Used for 12G/b SAS or 6G/b SATA signal transmission.
10	PMBUS connector	The backplane power management bus is used to connect and communicate between the backplane and the motherboard.

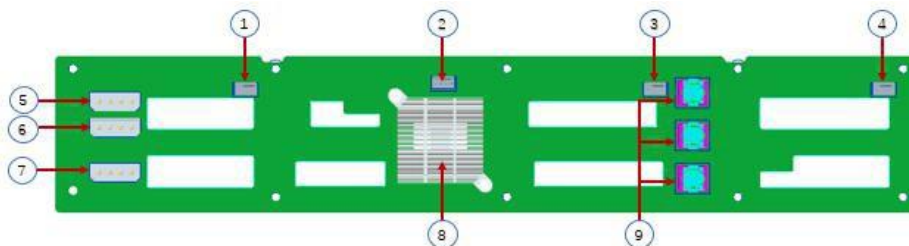

Figure 2- 11

Table 1- 17

● 2U8 expansion backplane as shown

TOP noodles

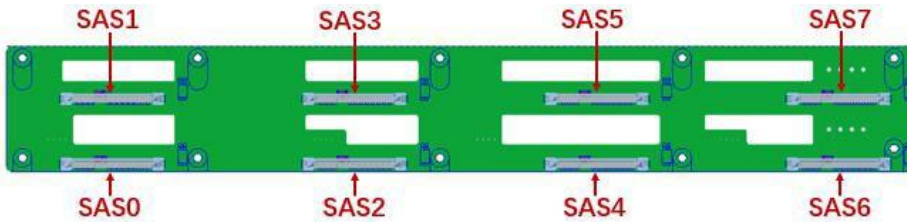

Figure 2- 12

Serial number	Description	Features
SAS0~7	SAS/SATA hard disk connector	1. Maximum support 12G/b SAS hard disk; 2. Maximum support 6G/b SATA hard disk; 3. Supports hot swap of SAS/SATA hard disks.

Table 1- 18

Bottom surface

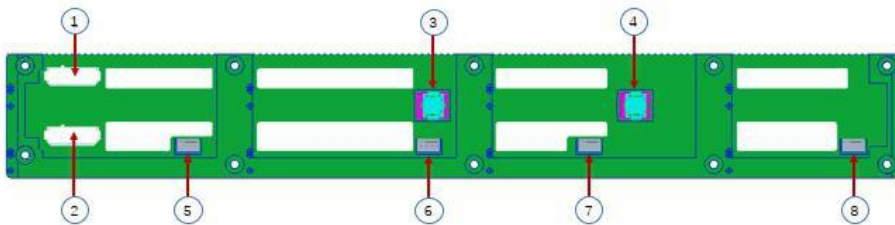

Figure 2- 13

Serial number	Description	Features
1, 2	ATX power input	Backplane power transmission connector for 12V power transmission
3, 4	SFF-8643 12Gb SAS interface	Backplane bay signal interface
5, 6, 7, 8	Temperature control fan socket	For 4pin fan interface

Table 1- 19

● SAS/SATA backplane as shown

TOP noodles

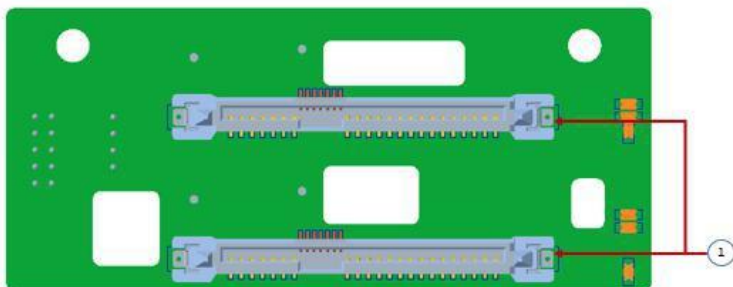

Figure 2- 14

Serial number	Description	Features
1	SAS/SATA connector	1. Maximum support 12G/b SAS hard disk; 2. Maximum support 6G/b SATA hard disk; 3. Supports hot swap of SAS/SATA hard disks.

Table 1- 20

Bottom surface

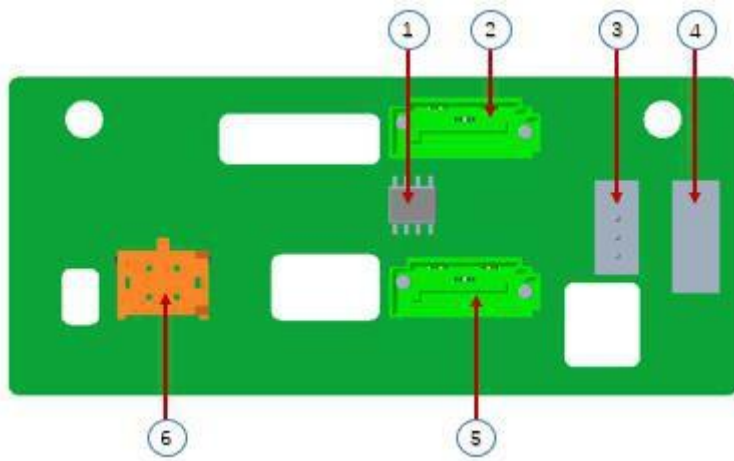

Figure 2- 15

Serial number	Description	Features
1	Temperature sensor IC	Temperature sensor chip
2, 5	7PIN SATA interface	SATA disk signal line interface
3	I2C interface	For I2C signal interface
4	SGPIO lighting signal	Used for hard disk LED positioning and fault LED indication Features.
6	Power connector	Backplane power transmission connector for 12V power transmission lose

Table 1- 21

- U.2 backplane as shown TOP noodles

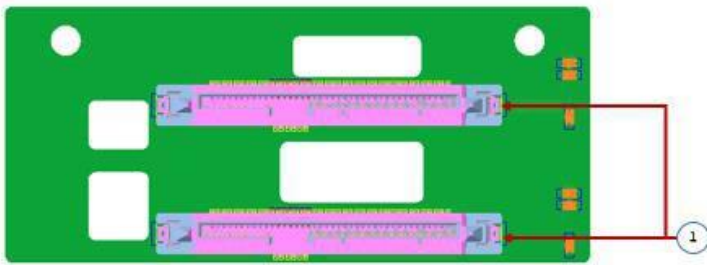

Figure 2- 16

Serial number	Description	Features
1	SFF-8639 connector	Support PCIe×4 U.2 interface, used to connect NVME SSD

Table 1- 22

Bottom surface

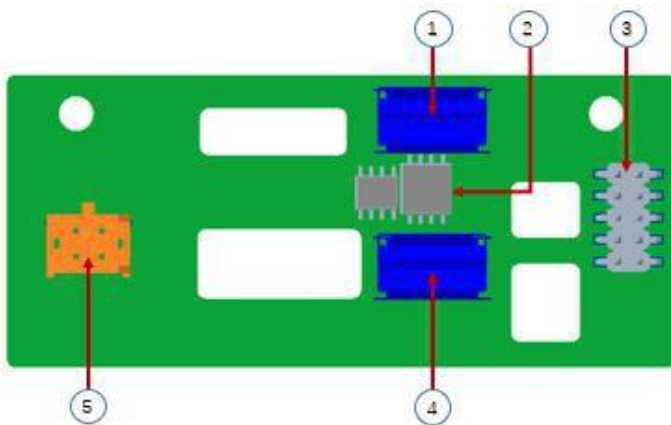

Figure 2- 17

Serial number	Description	Features
1, 5	Slimline 4i Connector	Provide PCIe×4 interface to connect CPU and NVME SSD1 (including CPU PEHP I2C and BMC I2C signal)
2	CPLD chip	For data logic processing
3	JATG debug interface	JTAG debugging interface, used to edit CPLD Process and version upgrade
4	Power outlet	4 Pin power socket, used to dock PSU or Docking MB 4 Pin plug to power the board

Table 1- 23

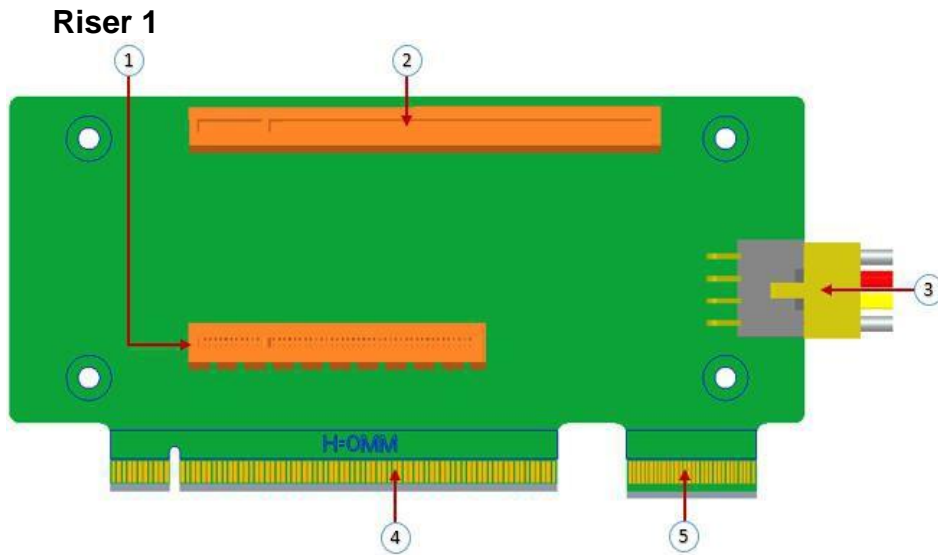

Figure 2- 18

Serial number	Description	Features
1	PCIE 3.0 X8 Slot	Used for PCIe 3.0 X8 devices.
2	PCIE 3.0 X16 Slot	Used for PCIe 3.0 X16 devices.
3	RISER POWER	Riser card power transmission connector for 12V power supply Transmission
4	PCIE X16 specification gold finger	For G3DCL motherboard PCIe X16 X8 interface
5	PCIE X8 specification gold hand Means	For G3DCL motherboard PCIe X16 X8 interface

Table 1- 24

Riser 2

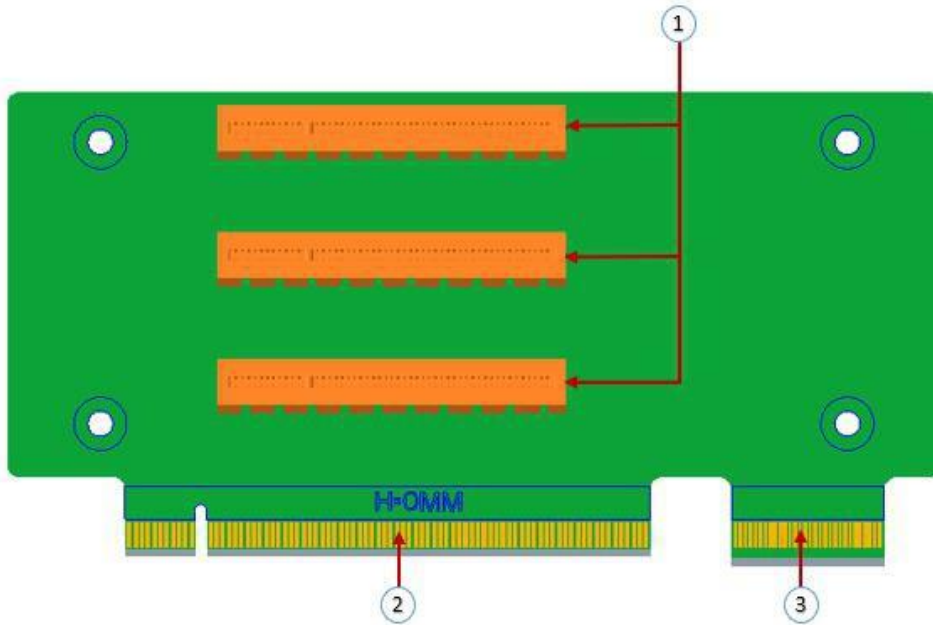

Figure 2- 19

Serial number	Description	Features
1	PCIe 3.0 X8 Slot	Used for PCIe 3.0 X8 devices.
2	PCIe X16 gold finger	For G3DCL motherboard PCIe X16 X8 interface
3	PCIe X8 gold finger	For G3DCL motherboard PCIe X16 X8 interface

Table 1- 25

Riser 3

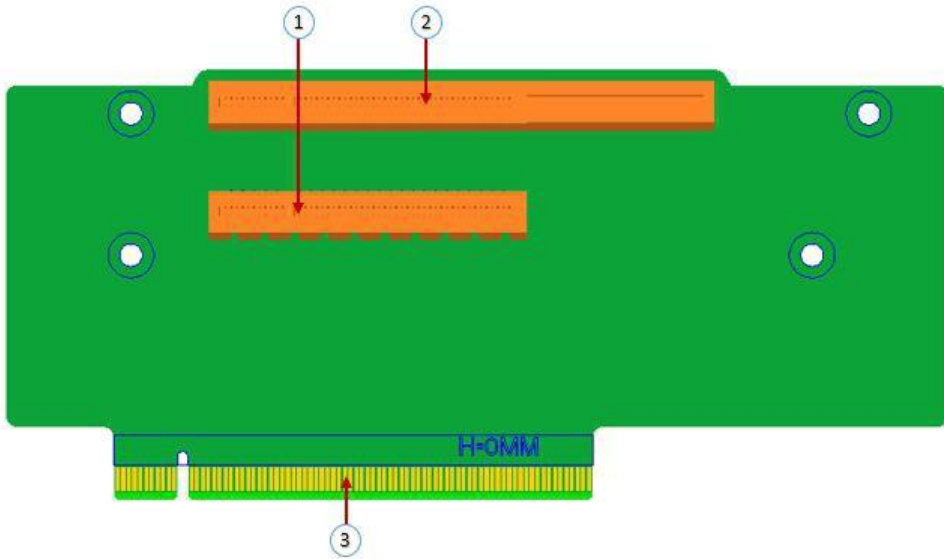

Figure 2- 20

Serial number	Description	Features
1	PCIE X16 Slot	Used for PCIe 3.0 X16 devices.
2	PCIE X8 Slot	Used for PCIe 3.0 X8 devices.
3	PCIE X16 specification gold finger	For motherboard PCIe X16 interface

Table 1- 26

Riser 4

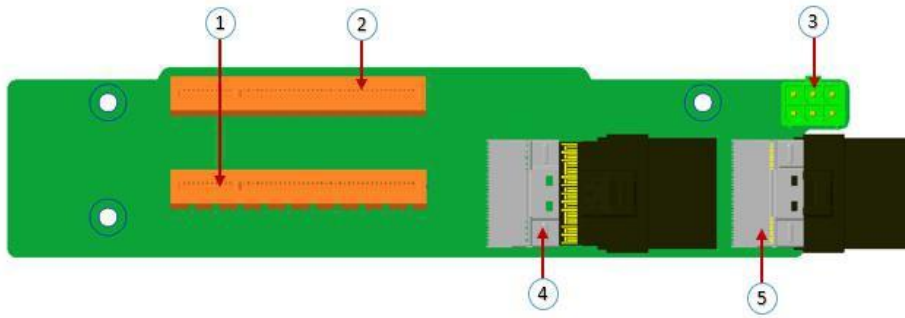

Figure 2- 21

Serial number	Description	Features
1	PCIE X16 Slot	Used for PCIe 3.0 X16 devices.
2	PCIE X8 Slot	Used for PCIe 3.0 X8 devices.
3	Power connector	Riser card power transmission connector for 12V power supply Transmission
4, 5	Slimline interface	For Slimline cable interface

Table 1- 27

2.4.5 DIMM slot location

The motherboard uses the Intel Purley platform, with Intel Xeon SkyLake CPU, supports 12 DDR4 Channels, 24 DDR4 slots (when only one memory is inserted, the plastic color of the slot on the slot board in the red box in the figure below is preferred), Supports DDR4 ECC RDIMMs/LRDIMMs server memory, memory frequency supports 2133/2400/2666/2933MHz; the location is shown in the figure below:

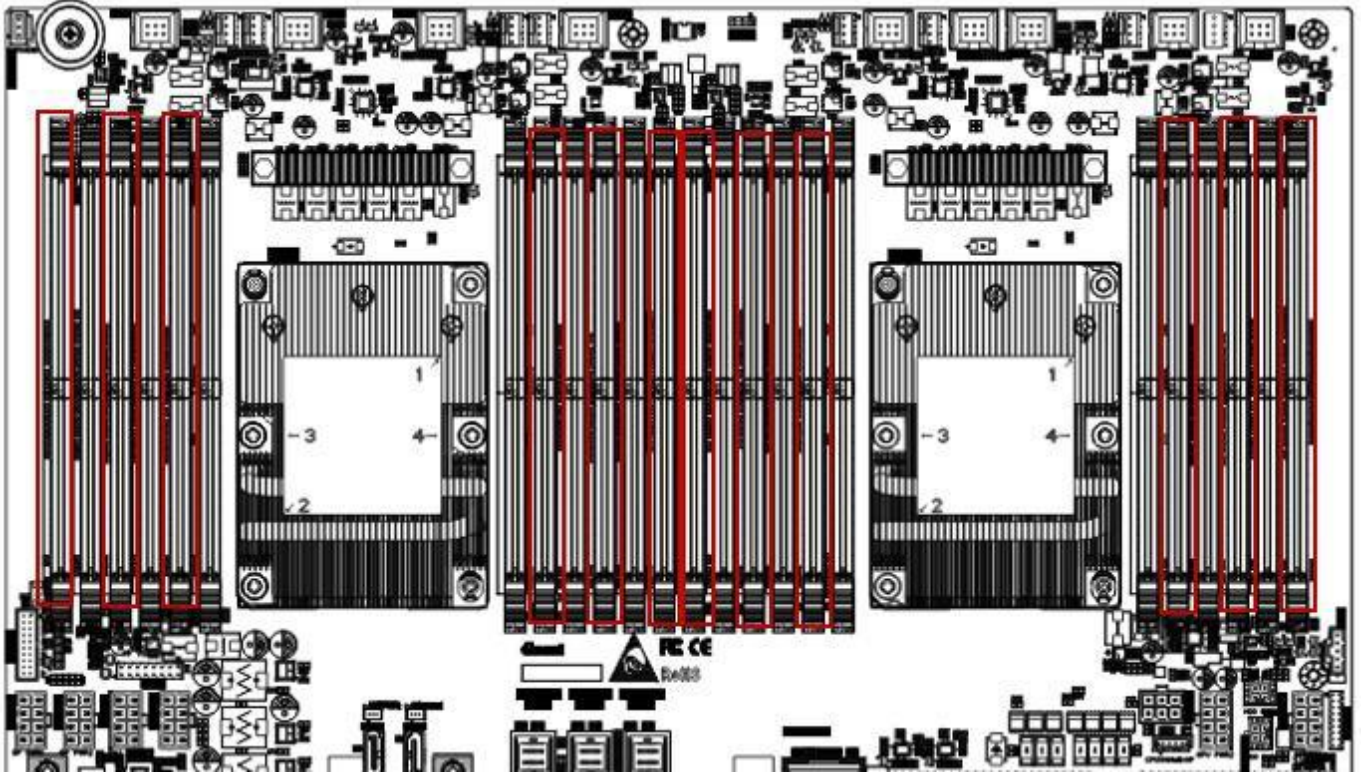

2.4.6 Figure 2- 22 Hard disk label

- 2U8 disk bay 3.5 inch disk model

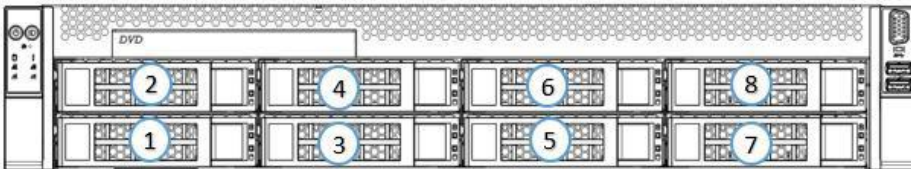

Figure 2- 23

- 2U12 disk bay 3.5 inch disk model

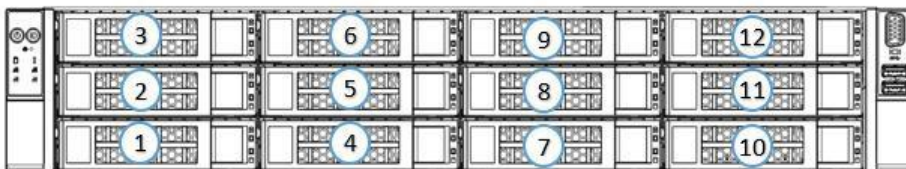

Figure 2- 24

2.4.7 Hard Disk Indicator

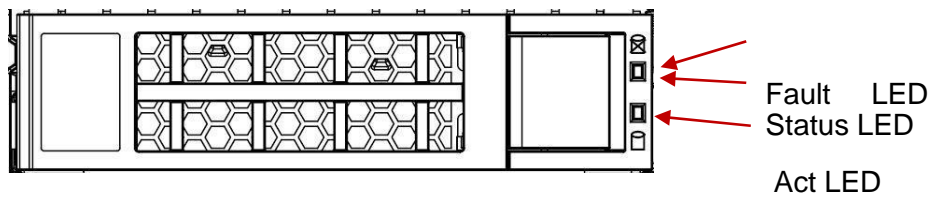

Figure 2- 25

Features	Act LED	Fault LED	Status LED
Hard drive in place	Chang Liang	OFF	OFF
Hard drive activity	Flashing 4Hz/sec	OFF	OFF
Hard disk positioning	Chang Liang	Flashing 4Hz/sec	OFF
Hard disk error	Chang Liang	OFF	Chang Liang
RAID reconstruction	Chang Liang	OFF	Flashing 1Hz/sec

Table 1- 28

2.4.8 System fan

The server supports variable fan speeds. Generally, the fan rotates at the lowest speed. If the server temperature rises, the fan will increase the speed to cool down.

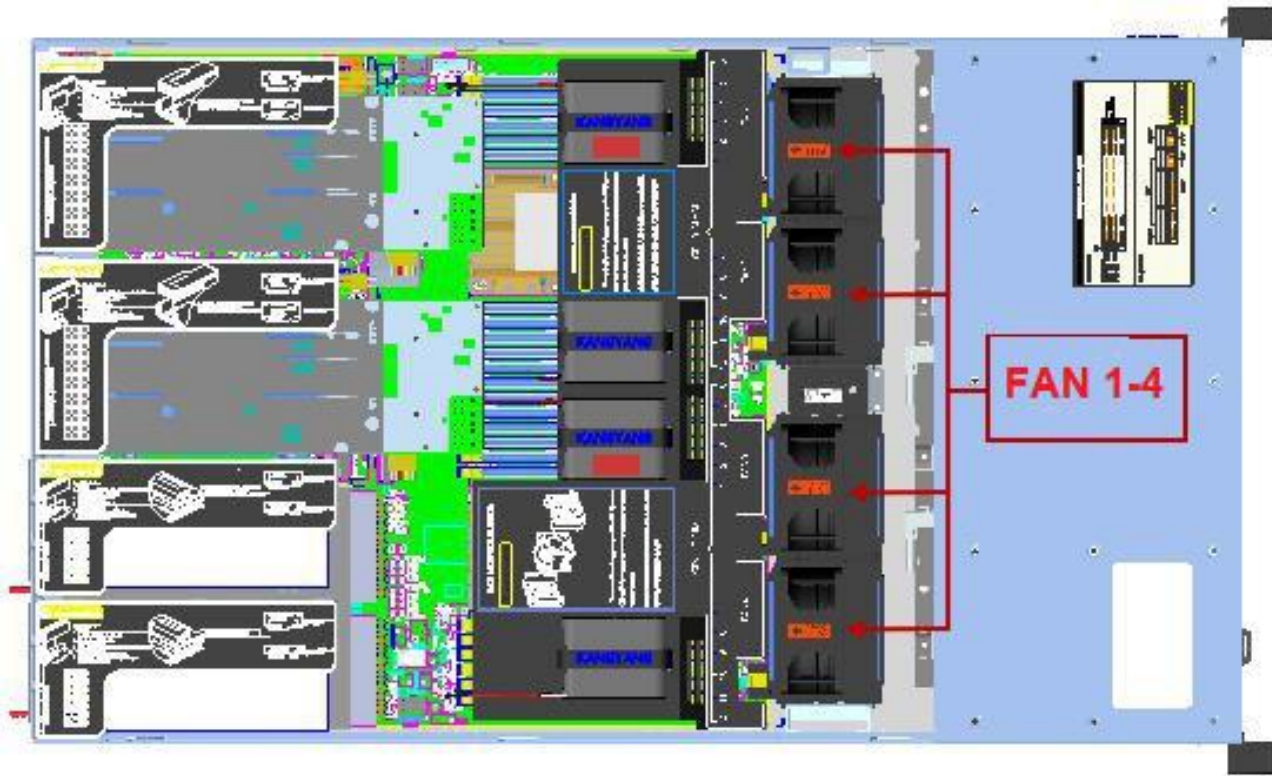

Figure 2- 27

Chapter 3 Installing System Components

3.1 CPU installation

- **Install the processor:**

Step 1: CPU installation

1. Tilt the CPU angle as shown in the figure, the A1 corner (triangular mark) is aligned, and it is stuck on one end of the clamping piece.
2. Direction, press the other end of the clamp to fix the CPU to the clamp.

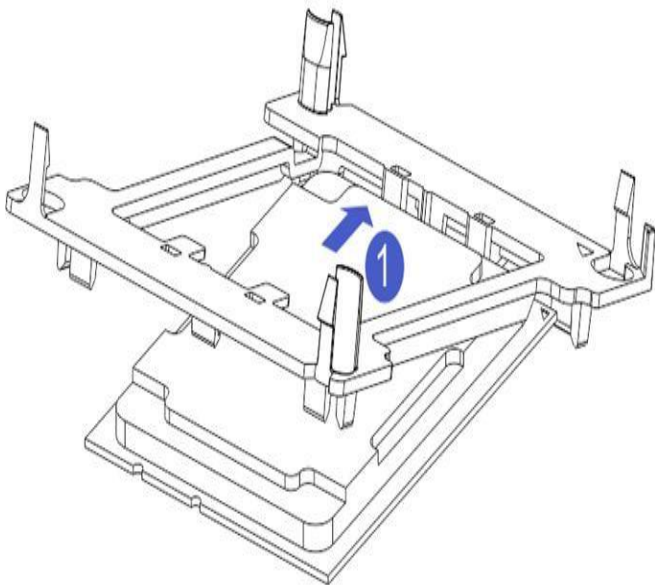

Figure 3- 1

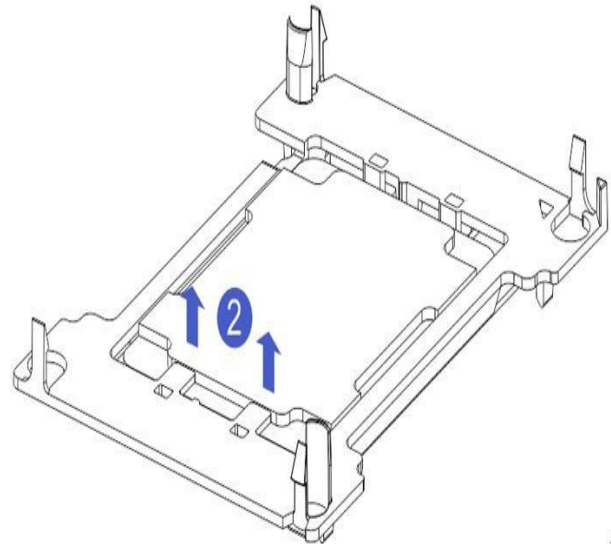

Figure 3- 2

Step 2: Install the CPU on the radiator to ensure that the surfaces of the CPU and the radiator are clean and free of oil and foreign matter. (As shown below)

1. Apply approximately 0.4ml thermal grease on the CPU and smooth it evenly.
2. Align the A1 corner (triangular mark) and buckle the CPU on the heat sink.

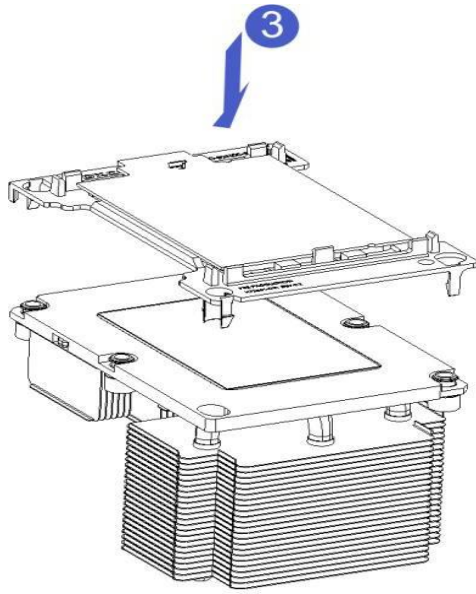

Figure 3- 3

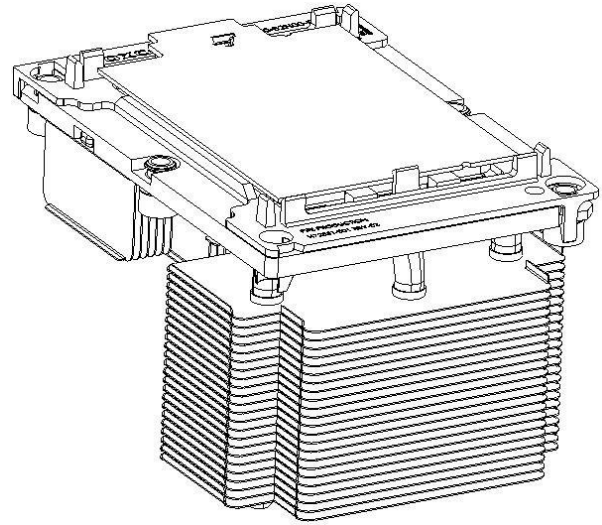

Figure 3- 4

3.2 Radiator installation

- installation steps:

1. Remove the processor blank (as shown below)

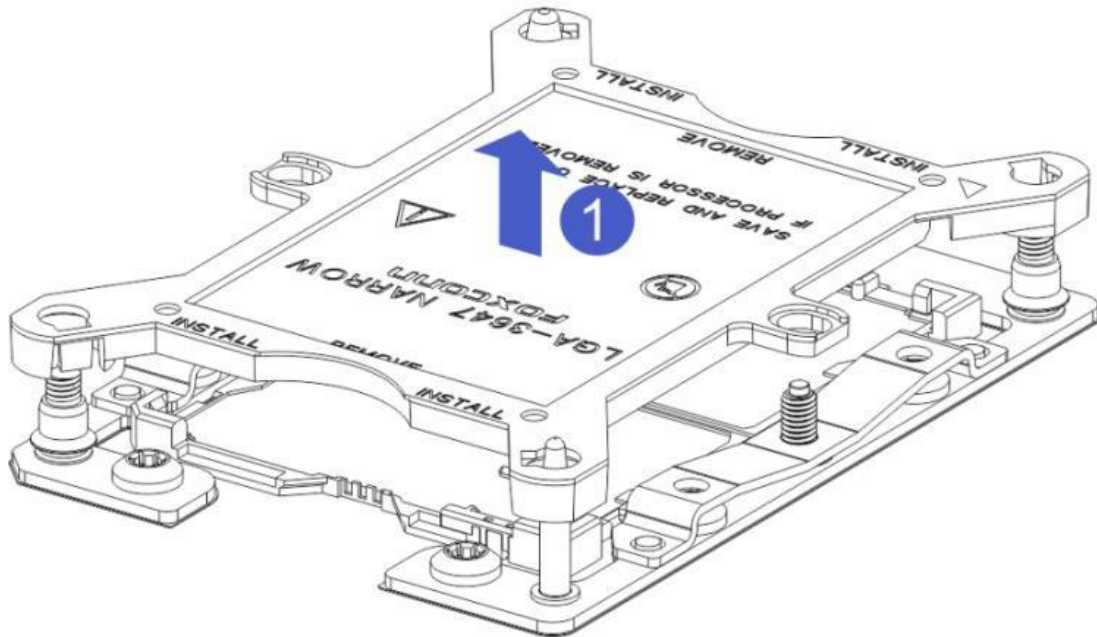

Figure 3- 3

2. Align the heat sink with the heat sink fixing studs on the CPU base, and tighten the fixing screws of the heat sink in sequence according to the instructions. (As shown below)
Note: The pins on the motherboard are extremely fragile and easily damaged. To avoid damage to the motherboard, do not touch the processor or processor socket contacts.

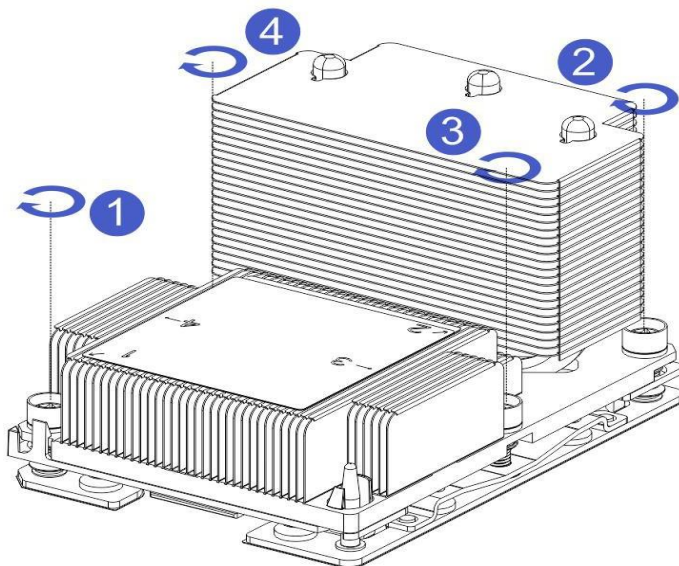

Figure 3- 4

3.3 Memory installation

The 8 memory slots controlled by the motherboard CPU 1 are: DIMMA1, A2, DIMMB1, B2, DIMM C1, C2 and DIMM D1, D2; The 8 memory slots controlled by CPU 2 are: DIMME1, E2, DIMMF1, F2, DIMMG1, G2 and DIMMH1, H2,

Note that the notch of the memory is consistent with the notch of the DIMM slot, and each DIMM module is vertically snapped in place to prevent incorrect installation.

Figure 3- 5

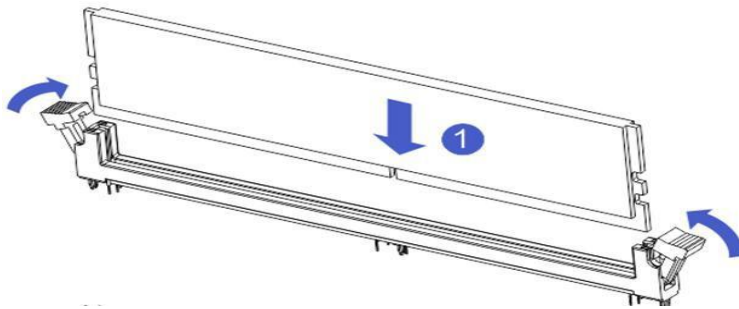
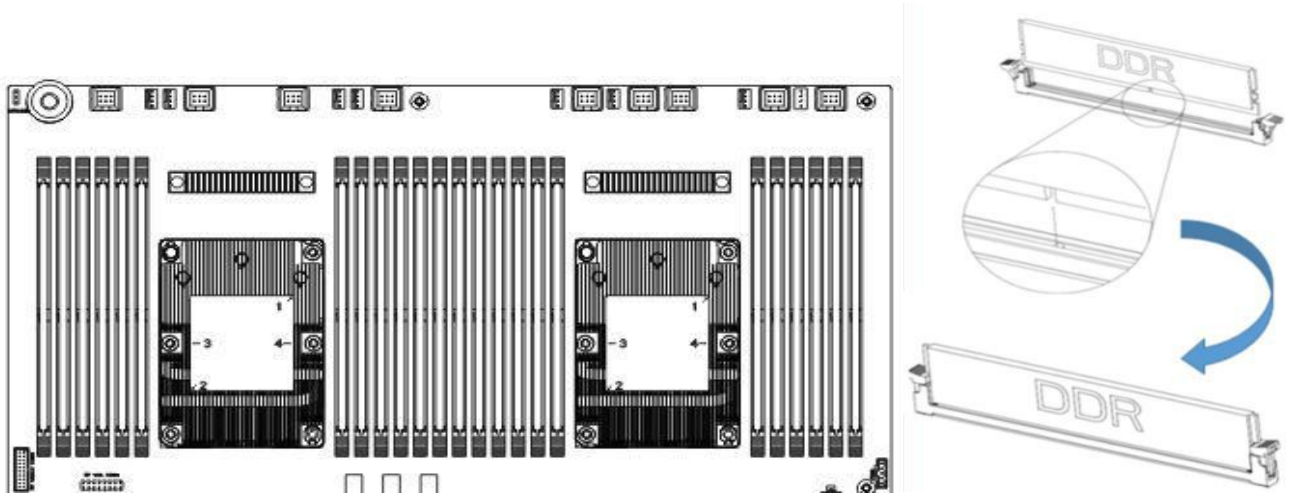

Figure 3- 6

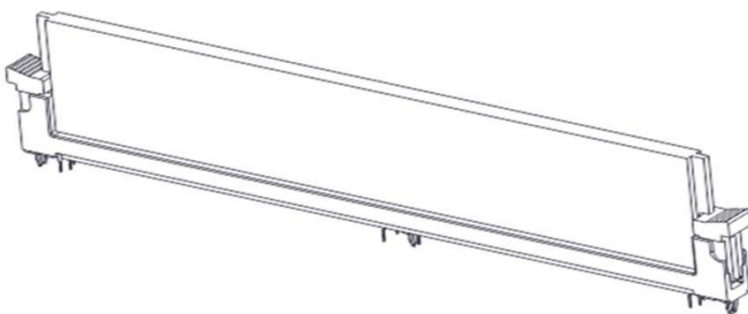

Figure 3- 7

3.4 Hard disk installation

- **Install 3.5 inch hard disk:**

1. Place the hard drive in the tray
2. There are a total of 4 countersunk screws on the left and right sides to lock the hard drive (the screw heads must not protrude from the surface of the slide rails on both sides of the tray)

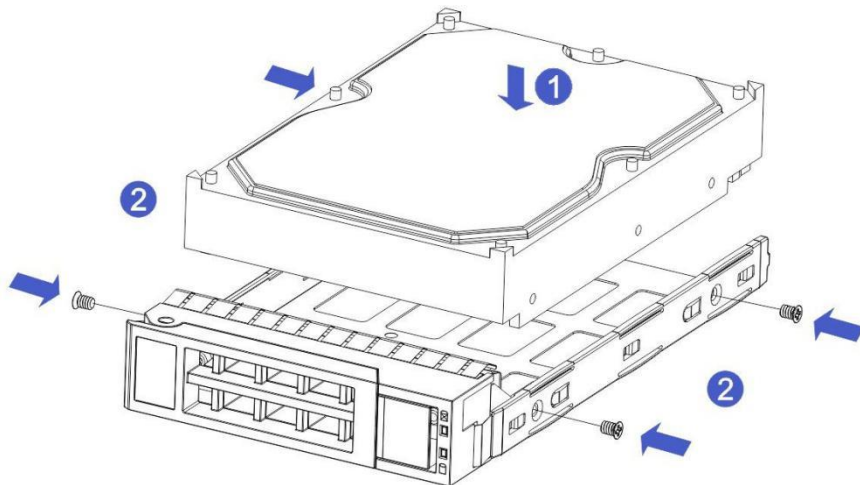

Figure 3- 8

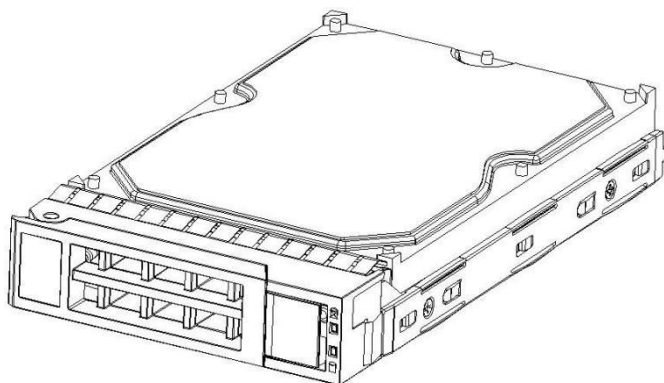

Figure 3- 9

● **Install 2.5 inch hard drive**

1. Place the hard drive in the tray
2. 4 countersunk screws at the bottom to lock the hard drive (the screw heads protrude from the bottom of the tray)

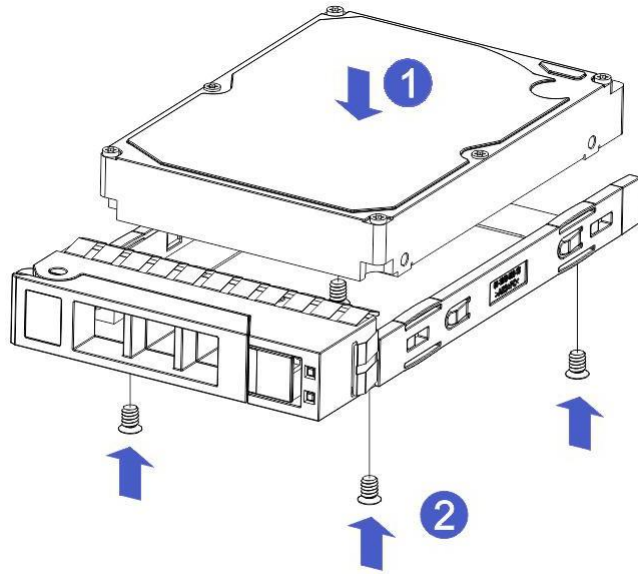

Figure 3- 10

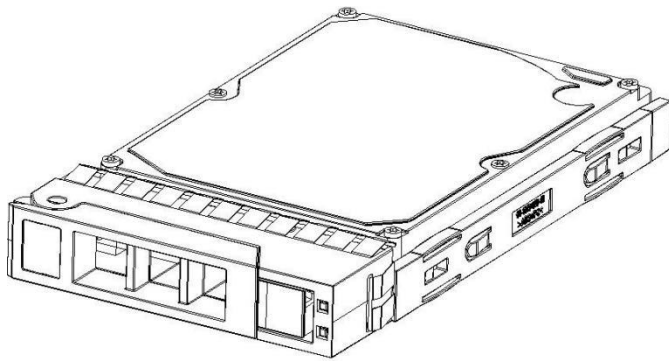

Figure 3- 11

Install the hard drive tray assembly into the chassis

1. With the hard drive wrench open, push it into the chassis
2. When the hard disk golden finger touches the backplane device, turn the wrench in the direction of the arrow
3. Schematic diagram of hard disk installation in place

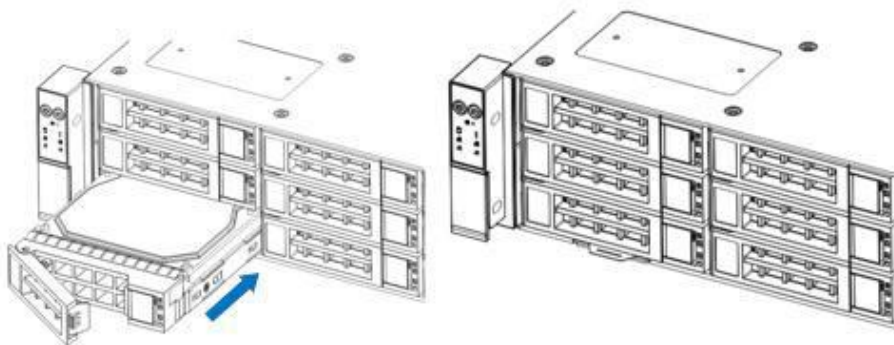

Figure 3- 12

3.5 Front hard disk backplane installation.

- **Front hard disk backplane installation:**

1. Align the gourd holes and hanging holes on the left and right sides of the hard disk backplane with the hanging nails of the hard disk frame and push in the direction of the arrow
2. After the hard disk backplane is pushed into place, press the backplane down until the gourd nails and hanging holes on both sides are all in place
3. Turn over the fixing parts on the left and right sides of the hard disk backplane and lay the fixing parts flat.

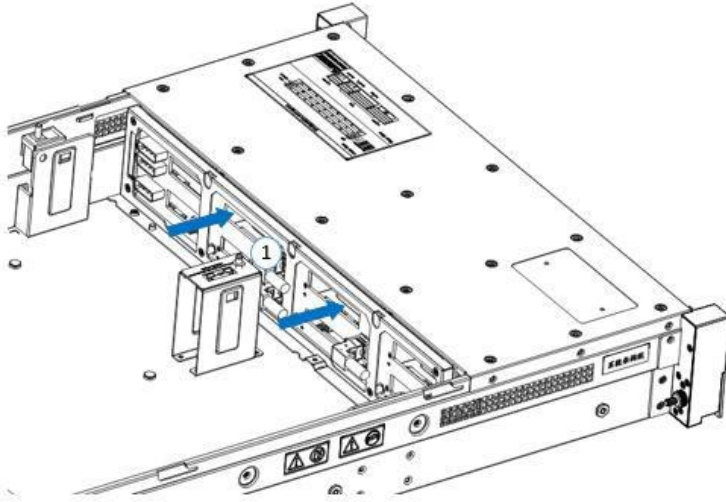

Figure 3- 13

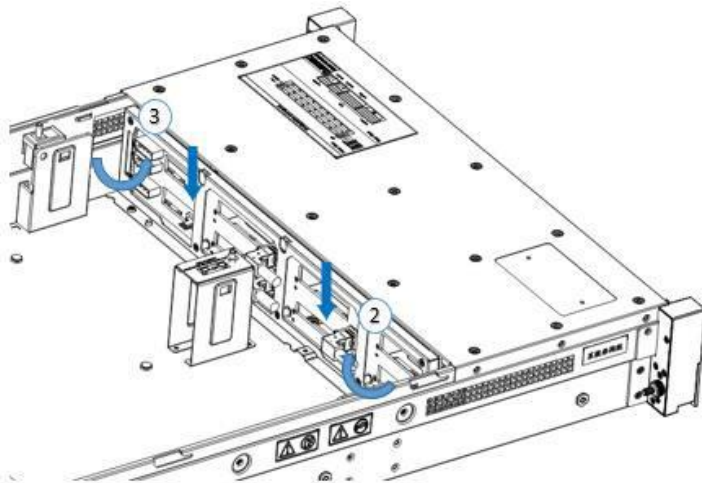

Figure 3- 14

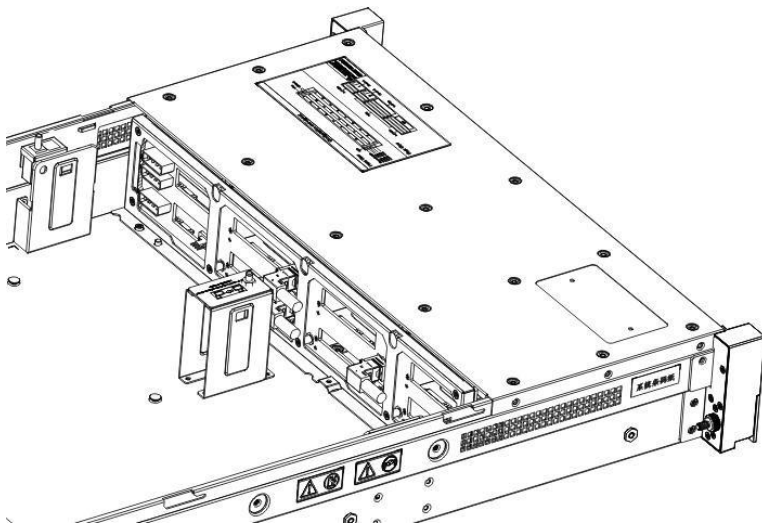
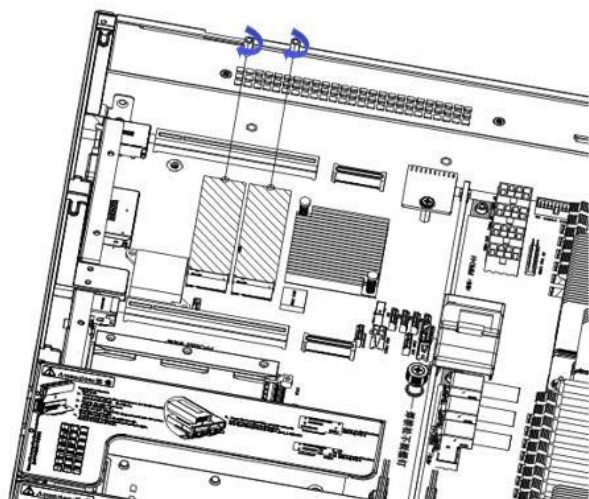

Figure 3- 15

3.6 M.2 SSD installation

Step 1: Install the positioning studs according to the length of the M.2 card to be installed.



Step 2: install M.2 card

Figure 3- 16

1. Insert the M.2 card connector end into the motherboard connector as shown in the figure.
2. Press the other end of the M.2 card to the plane of the positioning stud in step 1.

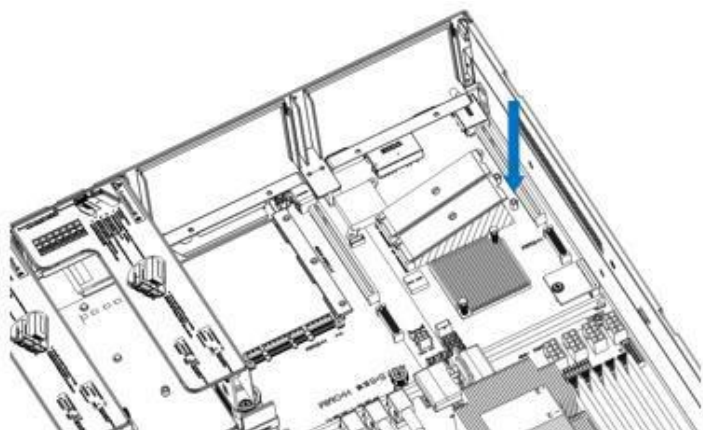

Figure 3- 17

Step 3: Install the fixing screws of the M.2 card.

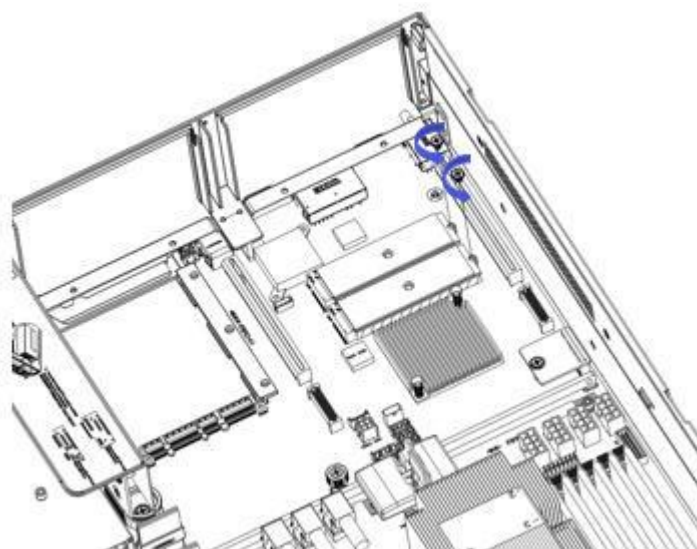

Figure 3- 18

3.7 PCI-E module installation

Riser 1-3 module installation steps: the rear window PCIE components, vertically downward-align the PCIE slot, align the positioning holes, and place it flush with the rear window.

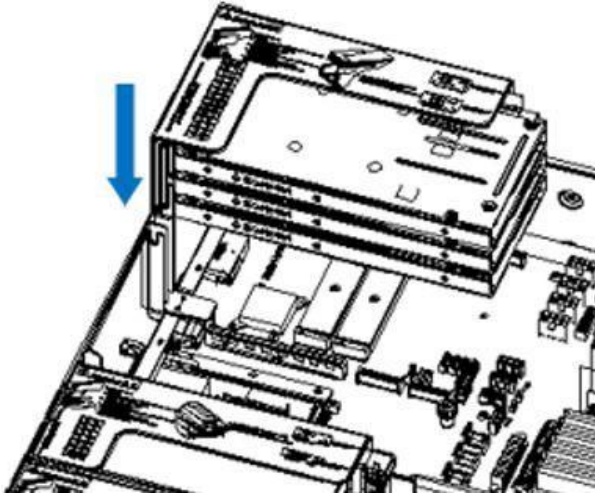

Figure 3- 19

Riser 4 module installation steps: rear window PCIE components, placed vertically downward-align the PCIE slot, align the positioning holes, place it flush with the rear window, and then tighten the side screws.

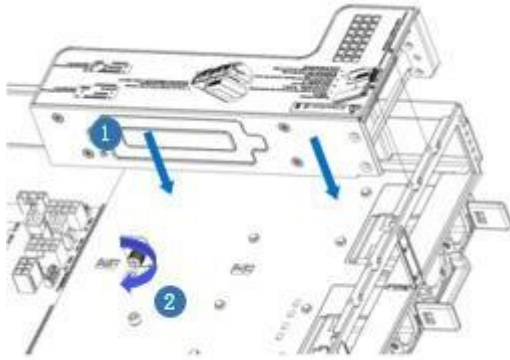

Figure 3- 20

3.8 Rear hard disk module backplane installation

Step 1: Install the rear hard disk module backplane

1. Pull the back plate limiting shrapnel outward with your hand, and hold the shrapnel with your hand-keep the shrapnel open
2. Align the nail holes of the hard disk backplane with the nails of the hard disk module bracket and push it forward, and then place it down in place, release the hard disk limit shrapnel, and the shrapnel automatically springs back to the original position;
3. Turn over the fixing parts on the hard disk backplane, as shown in the figure-the fixing parts can be placed flat.

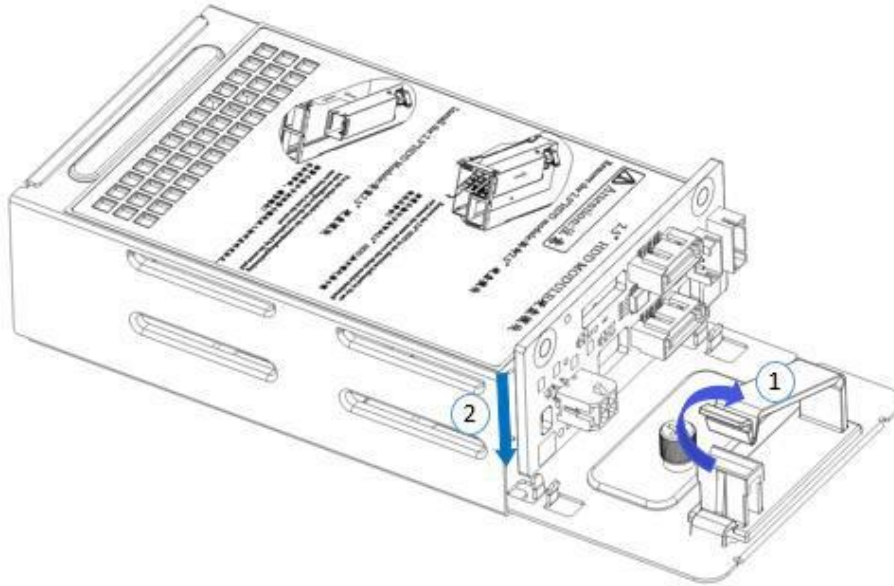

Figure 3- 21

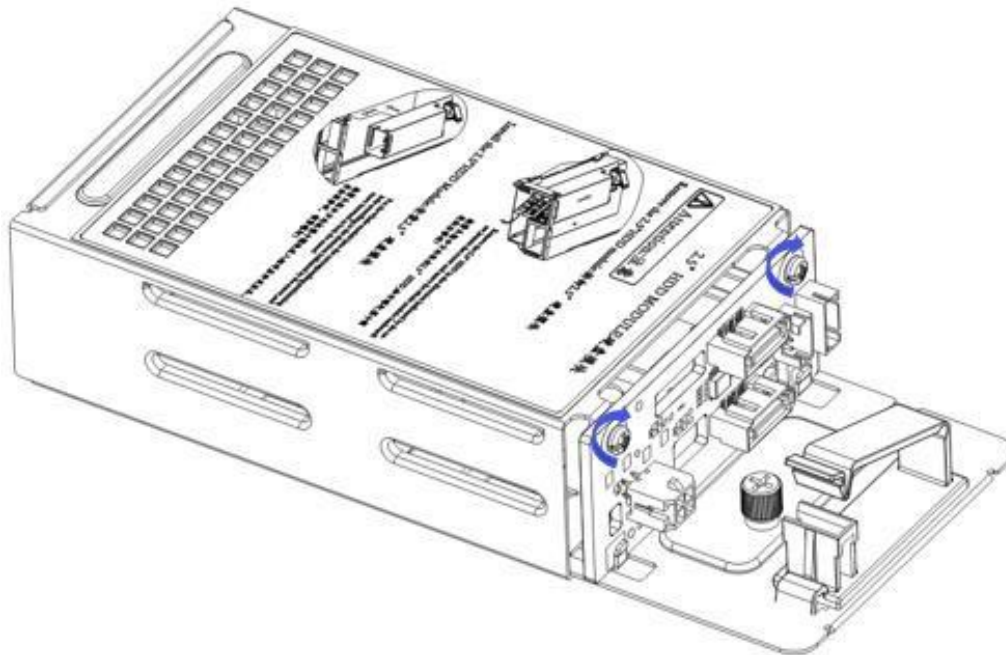

Figure 3- 22

3.9 Rear hard disk module installation

- **Rear 3.5 inch HDD tray installation**

Step 1. Place the HDD tray vertically downward and flush with the rear window

Step 2. Fix the rear HDD tray component

Step 3. Lock a captive screw

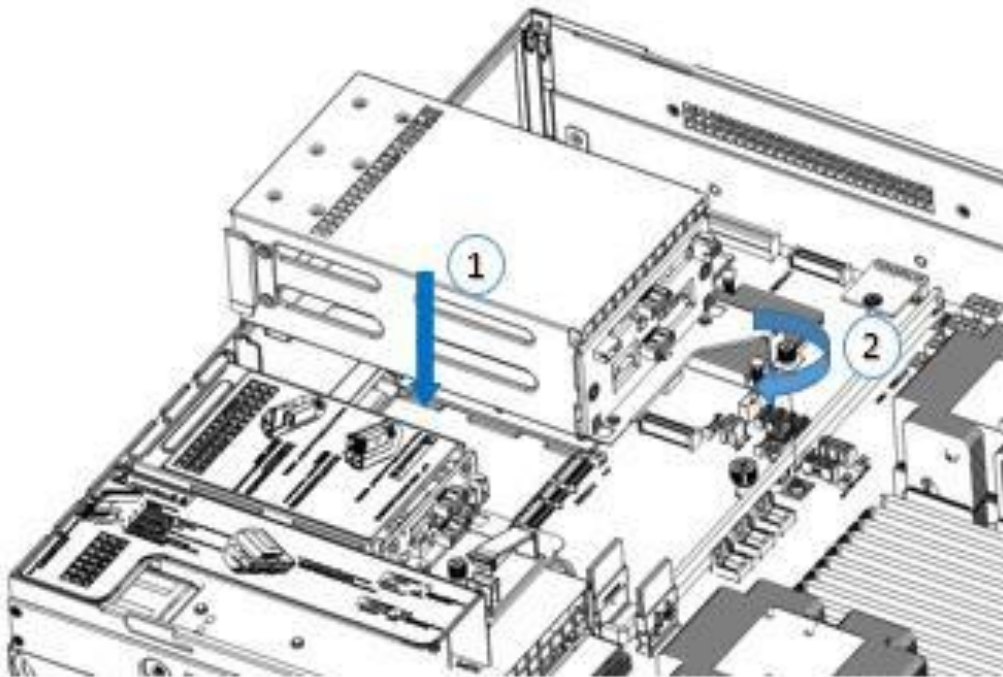

Figure 3- 23

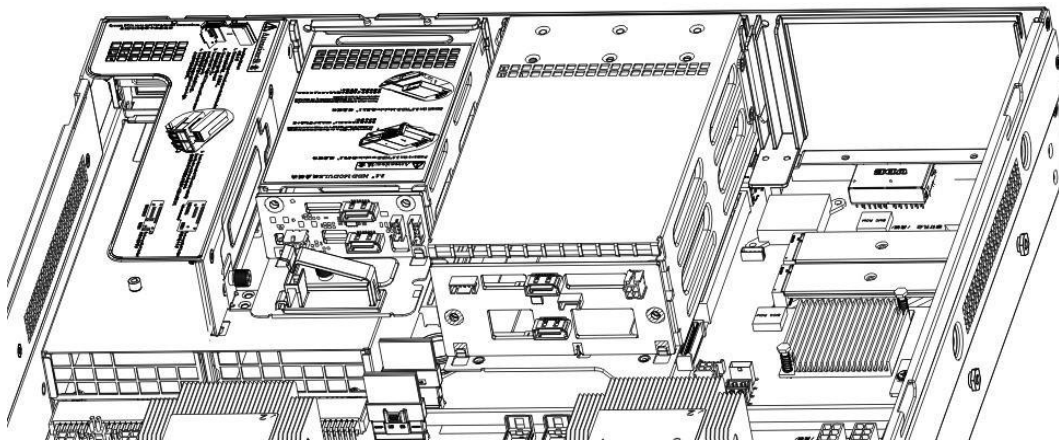

Figure 3- 24

- **Rear 2.5 inch HDD tray installation**

1. Place vertically downward, aiming at the guide pin at the lower end
2. After placing it flat, push it to the end in the direction of the arrow,
3. Lock the captive screws

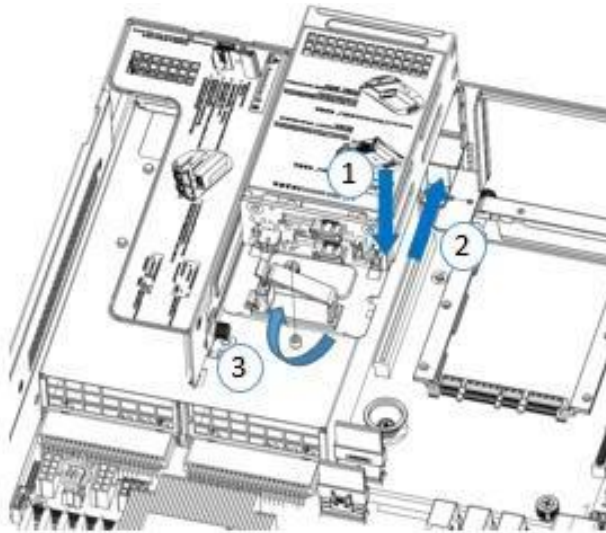

Figure 3- 25

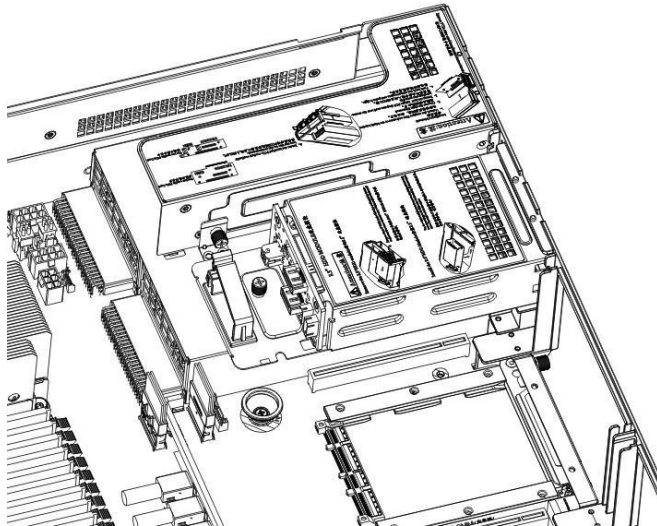

Figure 3- 26

3.10 Power supply module installation

Step: Push the power supply in the direction of the arrow to the end, and the shrapnel wrench on the right makes a clicking sound, indicating that it is installed in place;

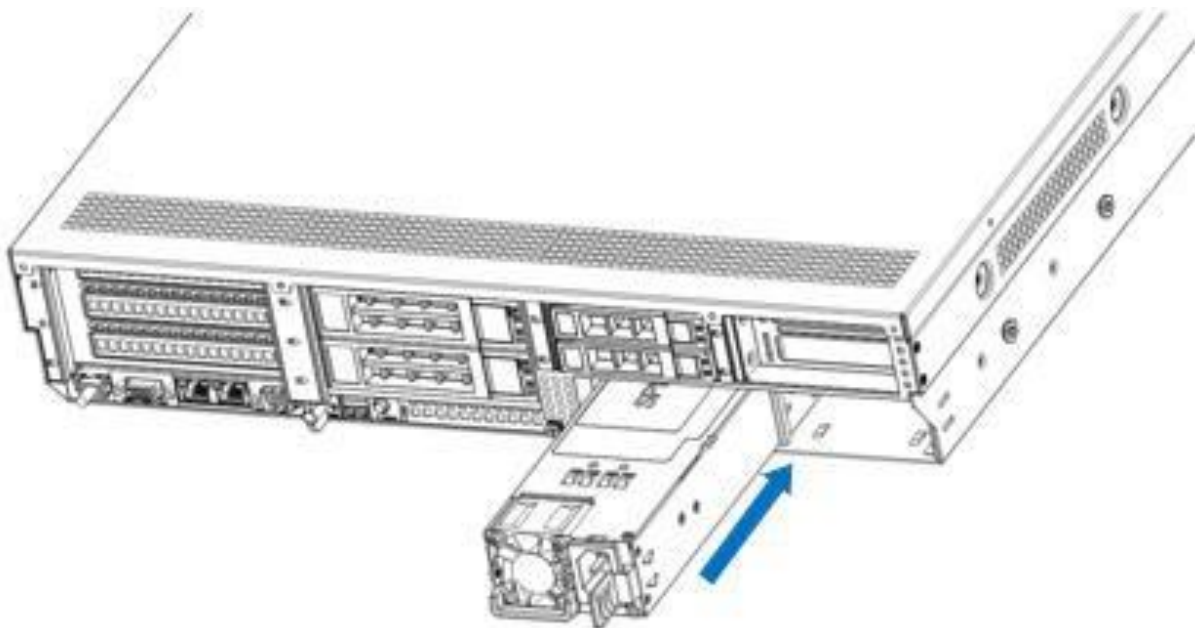

Figure 3- 27

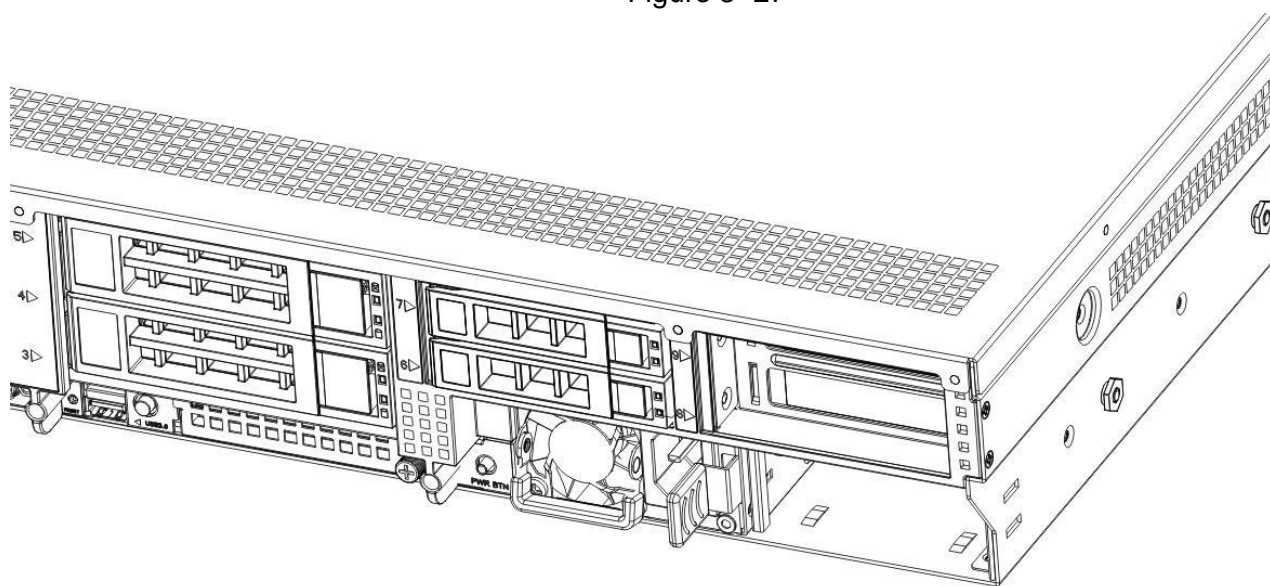

Figure 3- 28

3.11 PCI-E expansion card installation

Steps: install PCIE card

1. Install the PCIE card in the direction indicated in the figure
2. Rotate the PCIE card lock
3. Follow the arrow scheme to lock the PCIE card lock

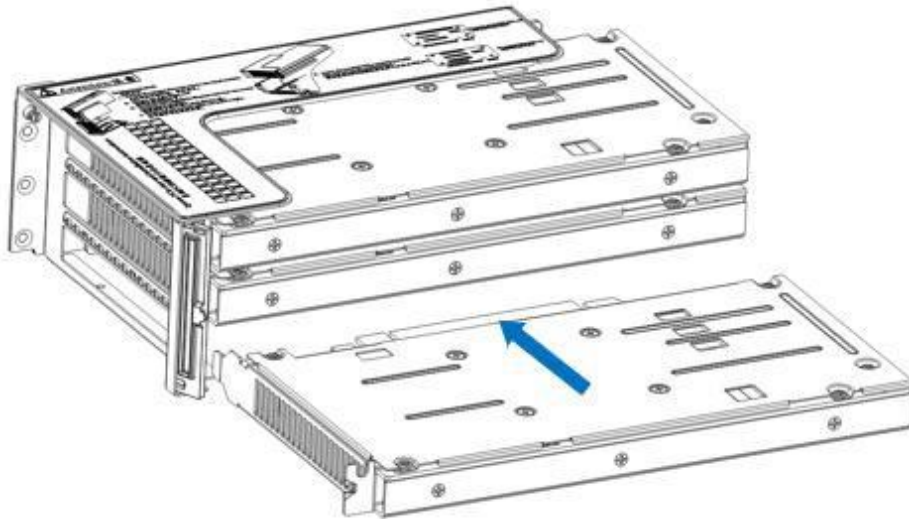

Figure 3- 29

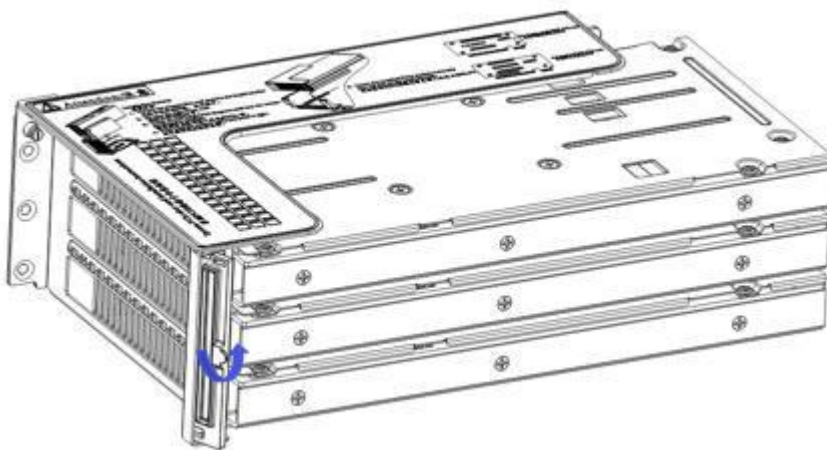

Figure 3- 30

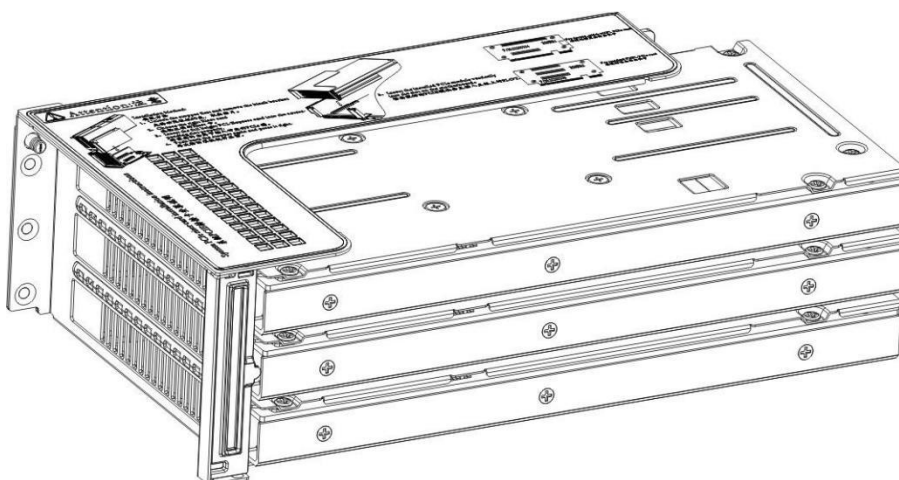

Figure 3- 31

3.12 Fan module installation

Steps: The fan module is placed vertically downward in the direction of the arrow (note the direction of the fan module).

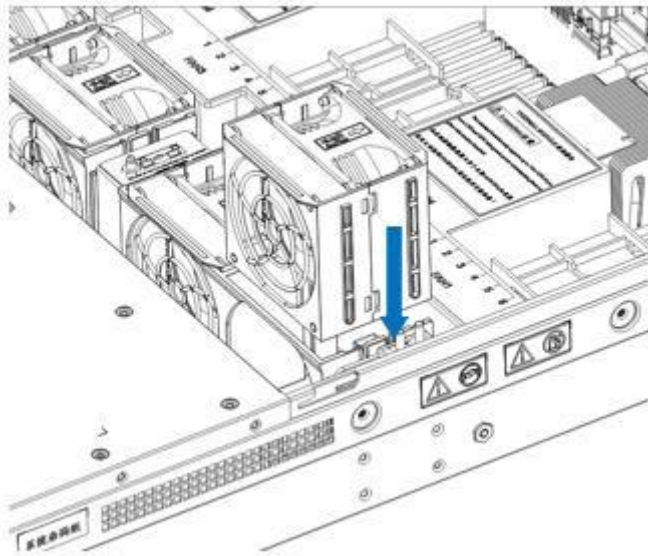

Figure 3- 32

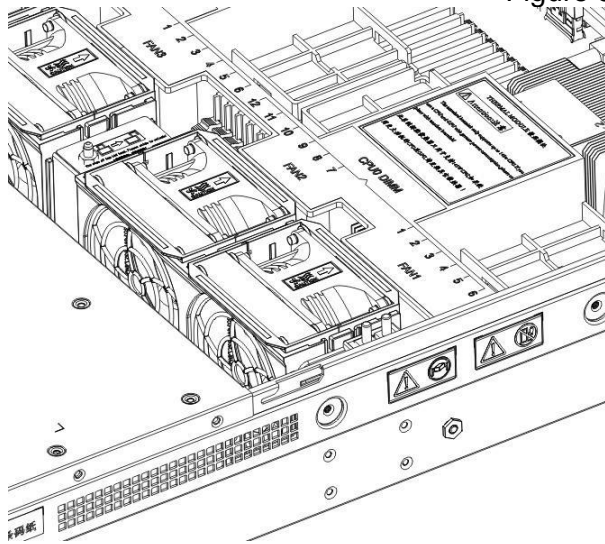

Figure 3- 33

3.13 Installation of air duct

Steps: align the air baffle module with the hanging points on the left and right sides and place it vertically downward-the height is lower than the height of the cabinet

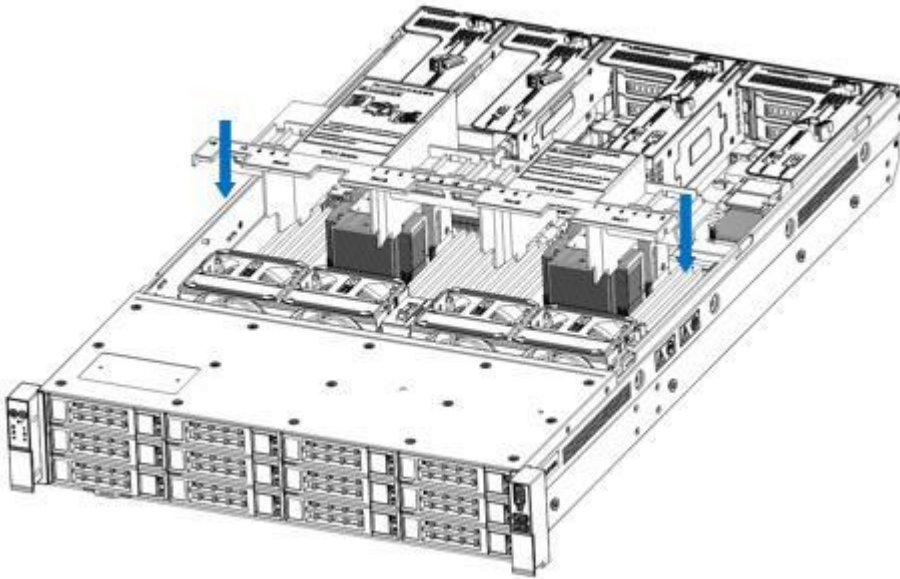

Figure 3- 34

3.14 CD-ROM installation

Step: install the optical drive

1. The optical drive is as shown in Figure 3-34:

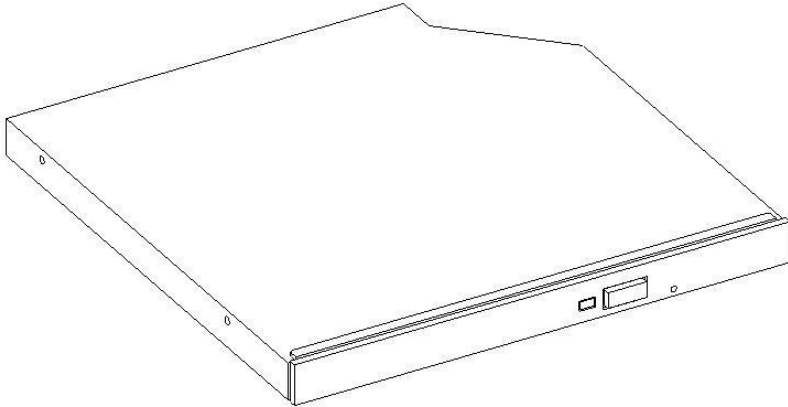
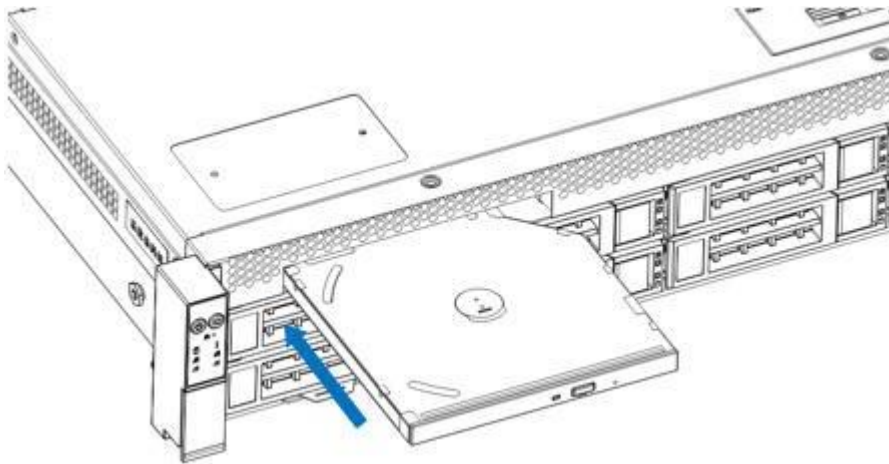

Figure 3- 35

2. Align the opening of the optical drive on the chassis, and push the optical drive in the direction of the



arrow until the fixing part is automatically locked.

Figure 3- 36

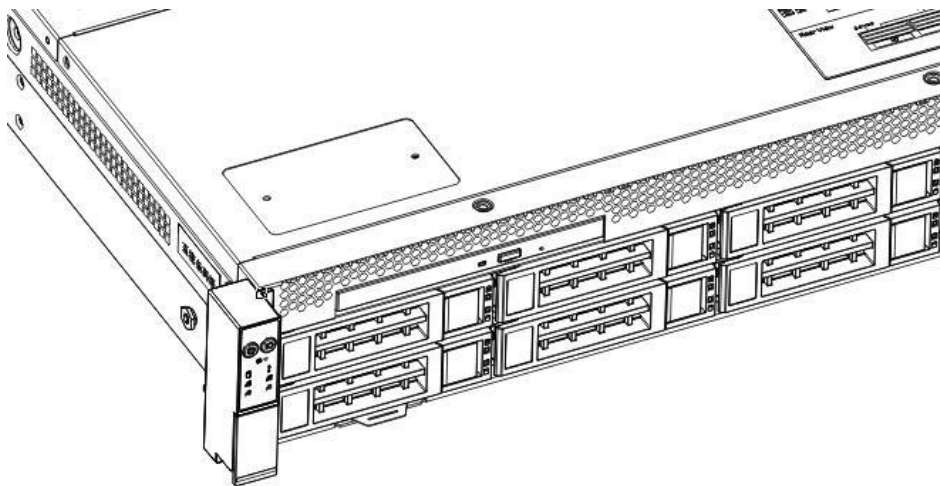

Figure 3- 37

3.15 Installation of the upper cover of the chassis

Step 1: Install the back cover of the chassis

1. Align the top cover with the opening position of the box and place it down
2. Rotate the upper cover lock in the direction of the arrow to lock it in place

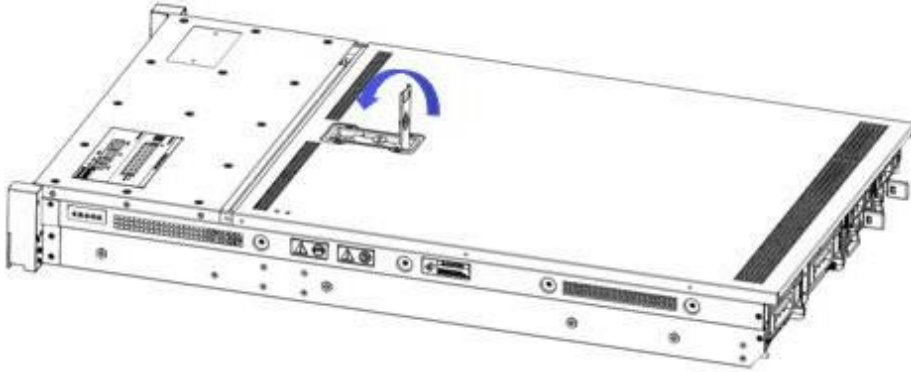

Figure 3- 38

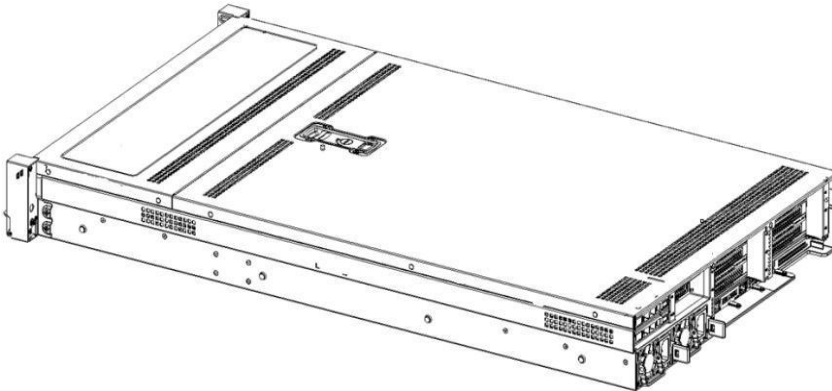

Figure 3- 39

Chapter 4 System cabinet Installation

4.1 Rail installation

Step 1. Prepare two sliding rail frames and draw out the inner rail.

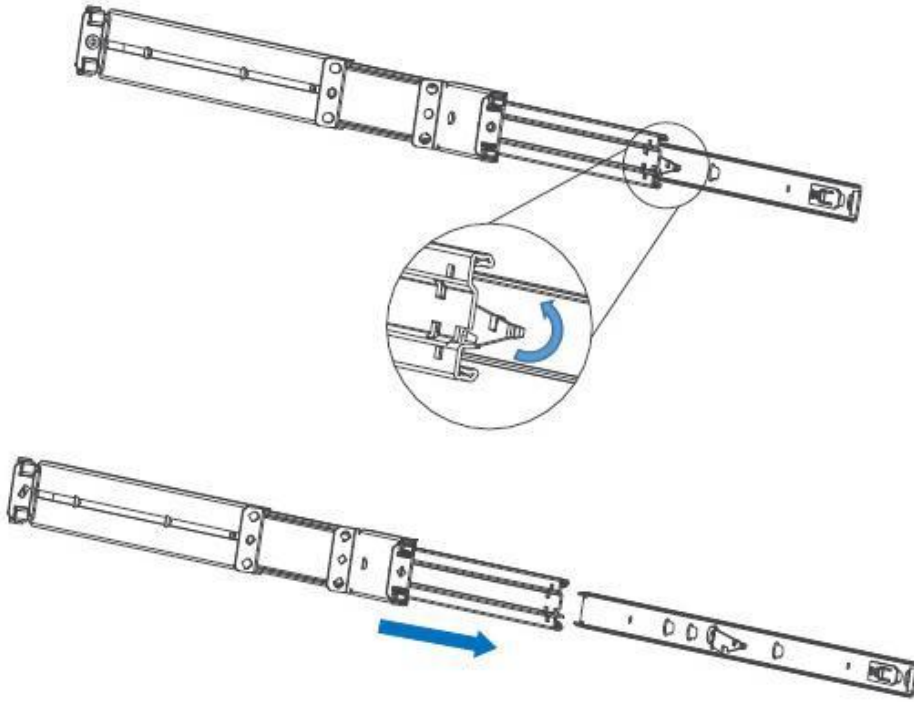

Figure 4- 1

Step 2. Fix the inner rails on both sides of the chassis.

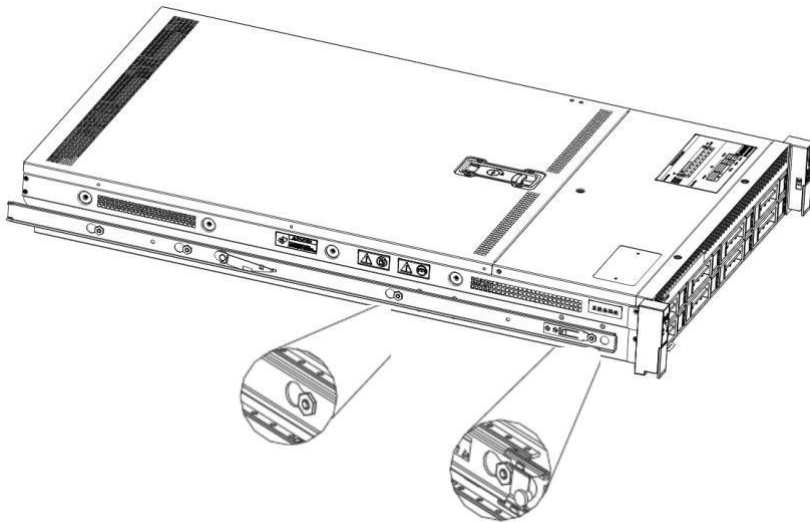

Figure 4- 2

4. 2 Install the outer rail to cabinet

Step 3. Install the outer rail on the cabinet bracket and tighten the screws.

Note: When installing the guide rail, you need to align the U mark, and install it in place with a snapping sound. Use M5 screws to secure it.

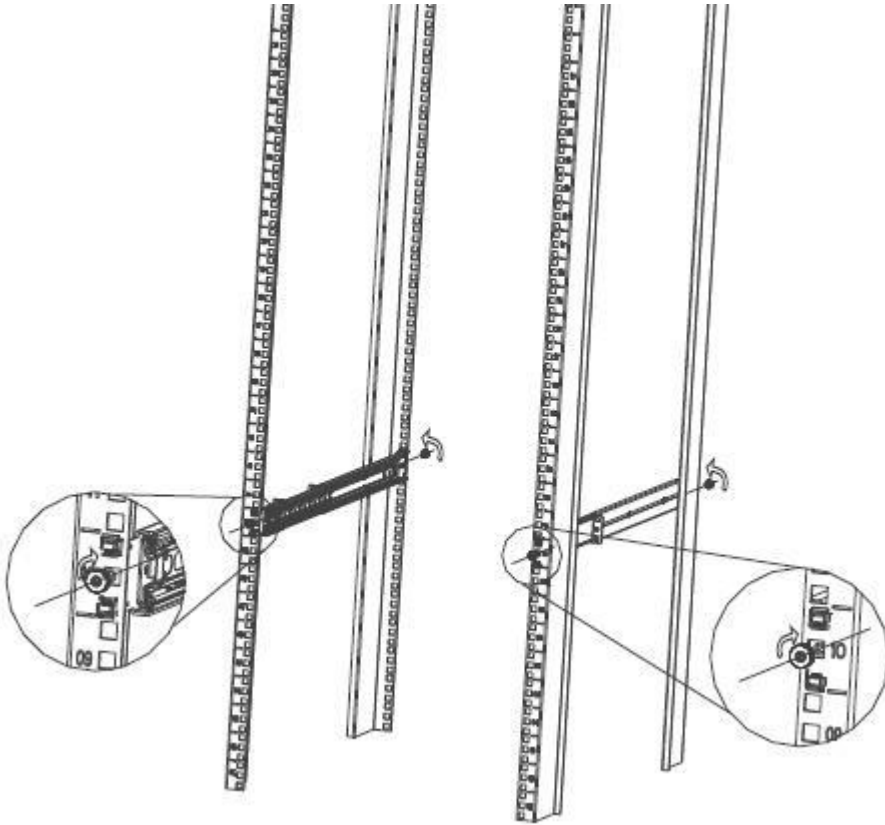

Figure 4- 3

4.3 Install server to cabinet

Step 4. Align the cabinet with the inner rail to the outer rail for installation.

Note: When you push the chassis forward, you hear a pop. If you can't push it, you need to pull the inner rail buckle down to continue pushing the chassis gently.

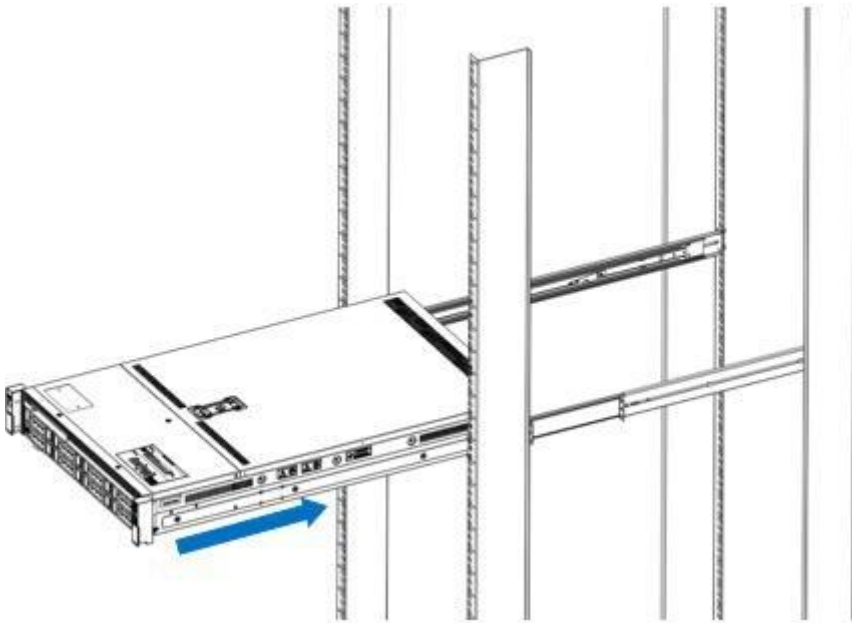

Figure 4- 4

Step 5. When the chassis is pushed forward and cannot slide, the screws are installed firmly.

Note: When the equipment is maintained, it is necessary to loosen the panel screws and gently pull the chassis. Do not push and pull the chassis at will, so as not to damage the equipment.

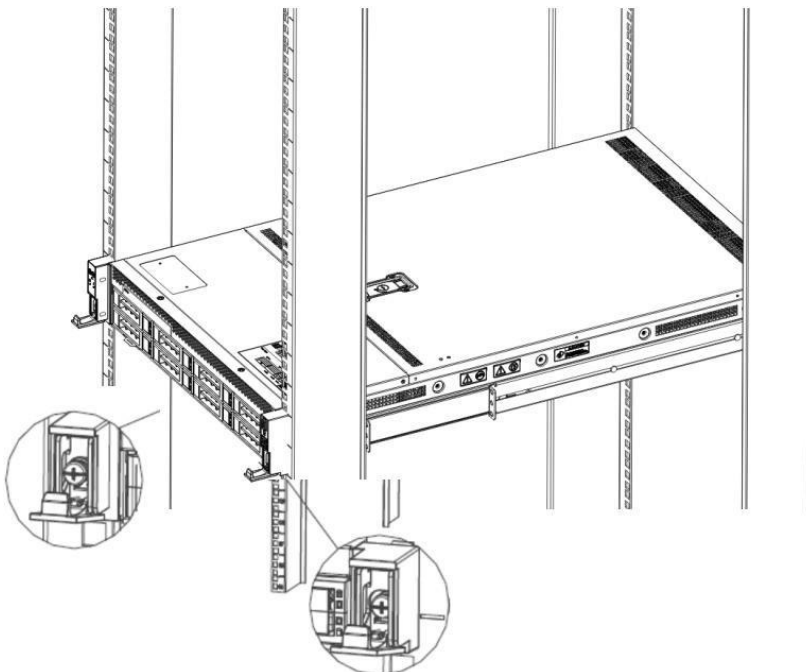

Figure 4- 5

Chapter 5 BIOS parameter setting description

5.1 Enter the BIOS Setup interface

Steps:

1. Power on the server motherboard and connect the keyboard;
2. During the POST process, pay attention to the prompt to enter the BIOS Setup interface at the bottom left of the Logo screen, "Press or <ESC> to enter setup, <F7> to enter Boot Menu.";
3. Press the keyboard or <ESC> key to prepare to enter the BIOS Setup interface;

5.2 Setup menu parameter description

5.2.1 Navigation key description

→←:	Menu switch (Select Screen)
↑↓:	Select Item
Enter:	OK (Select)
+/-:	Change Opt. (Change Opt.)
F1:	General Help
F2:	Previous Values
F3:	Optimized Defaults
F4:	Save changes and restart the system (Save & Reset)
ESC:	Exit

5.2.2 Main menu description

The Main interface contains the basic information of the BIOS system, such as the BIOS version number, CPU model, memory capacity, and the system time can be set.



Figure 5- 1

BIOS Information Project Version:

Display the BIOS version information of the board.

Build Date and Time:

Display the compilation date and time of the board BIOS.

BMC Firmware Revision:

Display the BMC version information of the board.

ME Firmware Version:

Display the version information of the board ME.

CPLD Name:

Display the CPLD name information of the board.

CPLD Version:

Display the CPLD version information of the board.

Build Date and Time:

Display the compilation date and time of the CPLD of the board.

Access Level:

Display the current user rights of the board.

Platform Information Processor:

CPUID and step information.

Processor Type:

CPU model information.

PCH:

PCH SKU and step information.

RC Revision:

Display the RC version information of the board.

Memory information Total Memory:

Display the total capacity of system memory.

Usable Memory:

Display the available memory capacity of the system.

System Language:

Select the current system language.

System Date:

Display and set the current system date. The format of the system date is "week month/day/year". Press "Enter" to switch between month, day, and year. You can change the value in the following ways:

- Press "+": the value increases by 1.
- Press "-": the value decreases by 1.
- Press the number keys: directly change the value.

System Time:

Display and set the current system time. The system time is in 24-hour format and the format is "hour:minute:second". Press "Enter" to switch between hour, minute, and second. You can change the value in the following ways:

- Press "+": the value increases by 1.
- Press "-": the value decreases by 1.
- Press the number keys: directly change the value.

5.2.3 Advanced menu description

The Advanced interface contains advanced configuration items of the BIOS system.

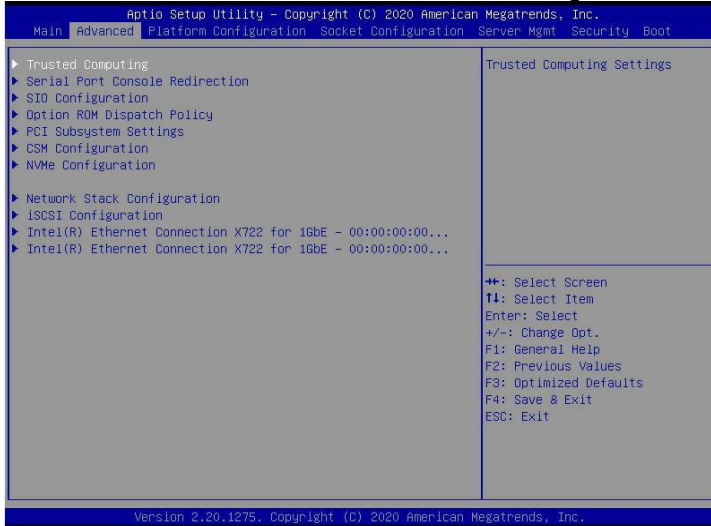

Figure 5- 2

- Trusted Computing

Trusted execution module configuration.

- Serial Port Console Redirection Serial port redirection configuration.
- SIO Configuration SIO configuration.
- Option ROM Dispatch Policy Option ROM call policy.
- PCI Subsystem Settings PCI Subsystem Settings.
- CSM Configuration CSM configuration.
- NVMe Configuration NVMe configuration.
- Network Stack Configuration Network Stack Configuration.
- iSCSI Configuration iSCSI configuration.
- Intel Ethernet Connection X722 for xGbE-XX:XX:XX:XX:XX:XX Intel xG network card UEFI OPROM configuration

5.2.4 Trusted Computing

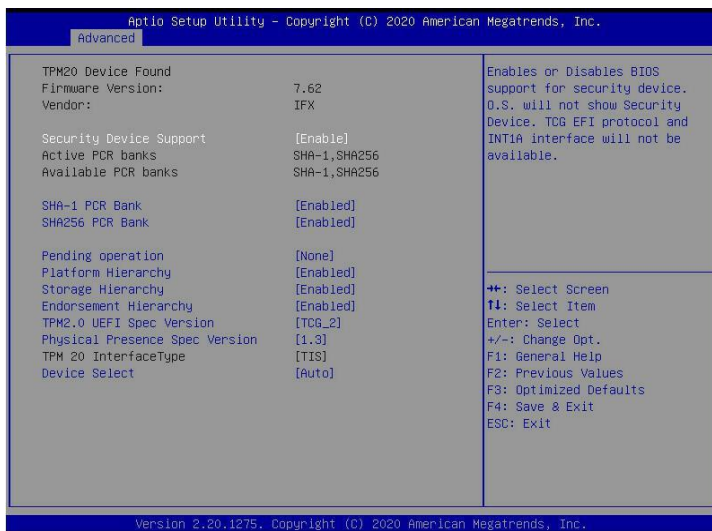

Figure 5- 3

Display and set the TCM/TPM module information. Different module options have different settings. The user can set according to the Setup help instructions.

5.2.5 Serial Port Console Redirection

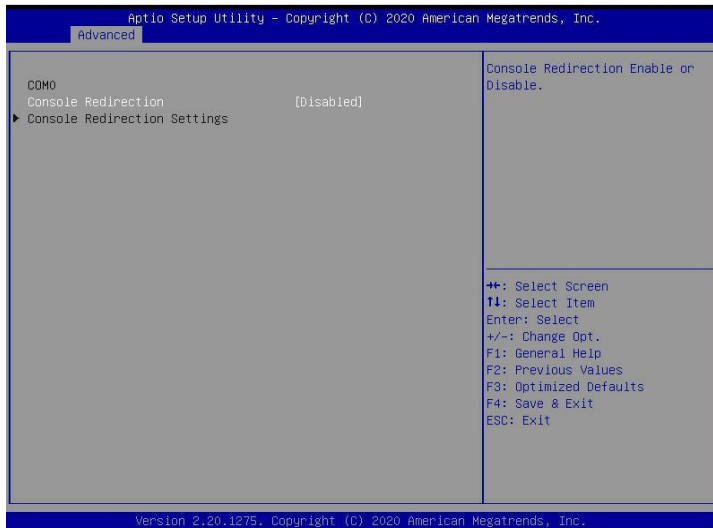

Figure 5- 4

Console Redirection

The console redirection function switch redirects the information output from the console (such as a graphics card) to the display to the serial port.

- Disabled: Turn off the redirection function.
- Enabled: Enable the redirection function. Default value: Disabled

5.2.6 Console Redirection Settings

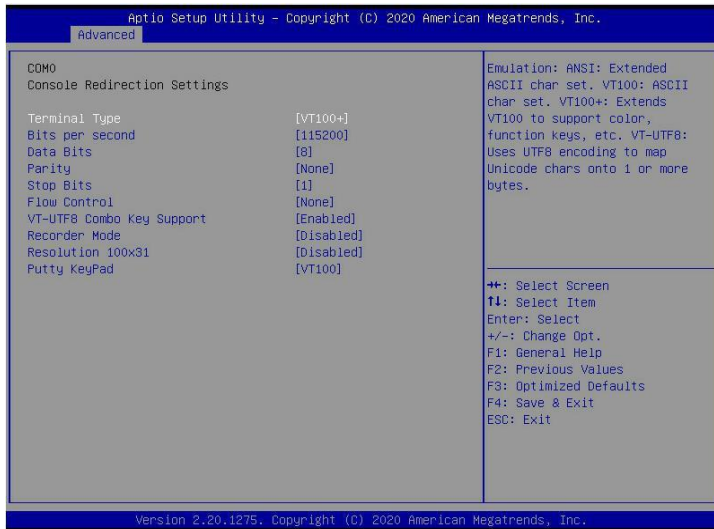

Figure 5- 5

Terminal Type

The emulation type can be selected through this option, and the BIOS emulation type must match the mode selected in the terminal program. The menu options are:

- VT100
- VT100+
- VT-UTF8
- ANSI

Default value: VT100+

Bits per second

Serial port redirection rate, the value range is 9600~115200 Default value: 115200

Data Bits

Serial port redirection data bit length, the menu options are:

- 8
- 7

Default value: 8

Parity

Serial port redirection check switch, the menu options are:

- None: No verification
- Even: Even parity
- Odd: odd parity
- Mark: The check digit is always 1
- Space: Check digit is always 0 Default value: None

 Mark and Space checks are not allowed to detect errors.

Stop Bits

Serial port data packet end flag, the menu options are:

- 1
- 2

Default value: 1

Flow Control

Serial port redirection control flow selection switch, the menu options are:

- None: Close the serial port redirection control flow
- Hardware RTS/CTS: Request to send/Clear to send Default value: None

VT-UTF8 Combo key support

ANSI/VT100 terminal VT-UTF8 key combination supports switch, the menu options are:

- Disabled: Disable ANSI/VT100 terminal VT-UTF8 key combination support
- Enabled: Enable ANSI/VT100 terminal VT-UTF8 key combination support Default value: Enabled

Recorder Mode

Record mode switch, turn on this function, only text messages will be sent, the menu options are:

- Enabled: open
- Disabled: Closed Default value: Disabled

5.2.7 SIO Configuration

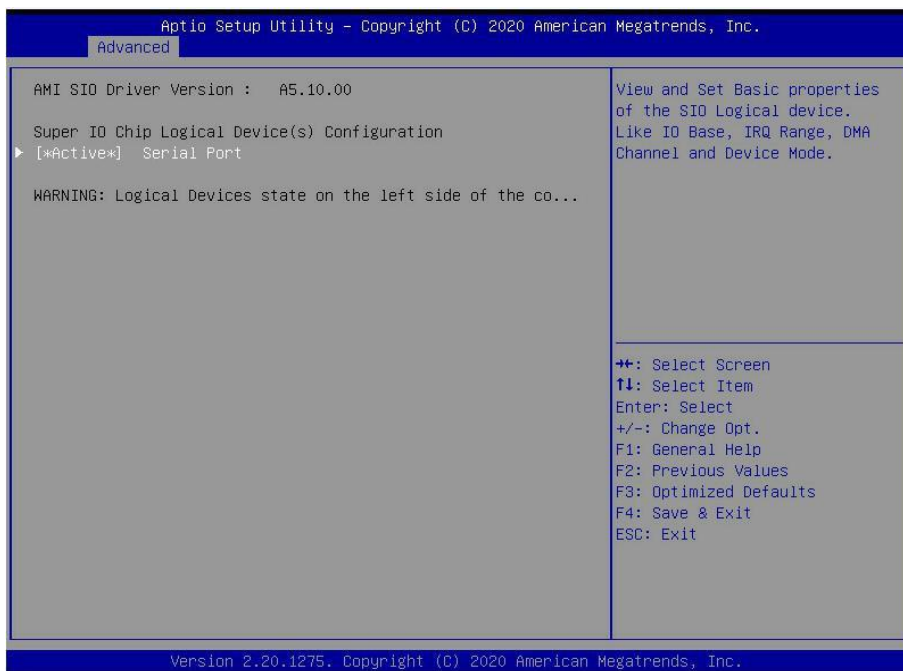

Figure 5- 6

5.2.8 [*Active*] Serial Port

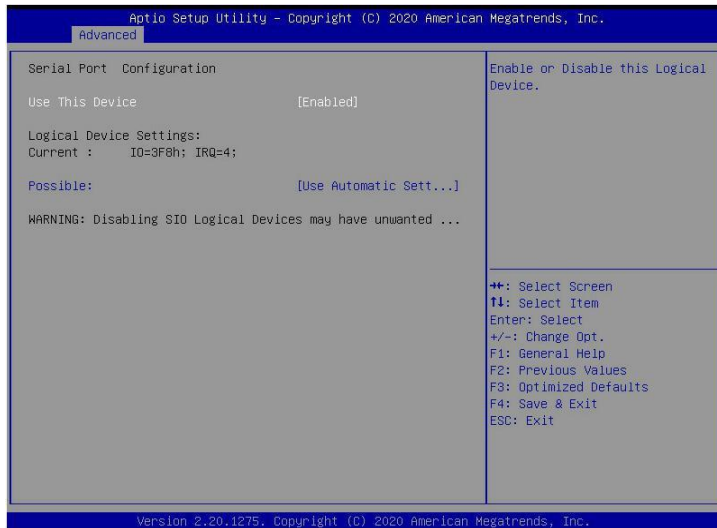

Figure 5- 7

Use This Device

With this device, the menu options are:

- Enabled: open
- Disabled: Closed Default value: Enabled

Possible

Choose the optimal settings for the serial port according to your needs, the menu options are:

- Use Automatic Settings
- IO=3F8h; IRQ=4; DMA;
- IO=3F8h; IRQ=3,4,5,7,9,10,11,12; DMA;
- IO=2F8h; IRQ=3,4,5,7,9,10,11,12; DMA;

- IO=3E8h; IRQ=3,4,5,7,9,10,11,12; DMA;
- IO=2E8h; IRQ=3,4,5,7,9,10,11,12; DMA;

Default value: Use Automatic Settings

5.2.9 Option ROM Dispatch Policy

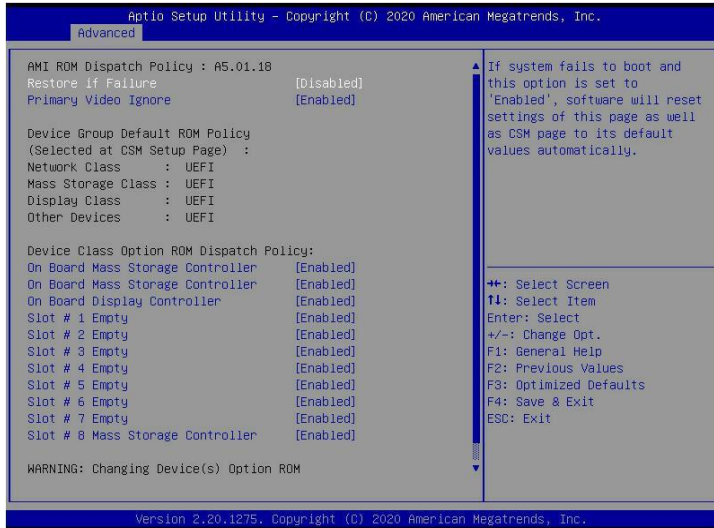

Figure 5- 8

Manage Option ROM call strategy Restore if Failure

When the fault is restored, the menu options are:

- Enabled: open
- Disabled: Closed Default value: Disabled

Primary Video Ignore

Ignore the basic graphics card, the menu options are:

- Enabled: open
- Disabled: Closed Default value: Enabled

On Board Mass Storage Controller Onboard or external device controller, the menu options are:

- Enabled: open
- Disabled: Closed Default value: Enabled

On Board Mass Storage Controller Onboard or external device controller, the menu options are:

- Enabled: open
- Disabled: Closed Default value: Enabled

On Board Display Controller

Onboard or external device controller, the menu options are:

- Enabled: open
- Disabled: Closed Default value: Enabled

Slot # 1 Empty

Onboard or external device controller, the menu options are:

- Enabled: open
- Disabled: Closed Default value: Enabled

...

Slot # 8 Empty

Onboard or external device controller, the menu options are:

- Enabled: open
- Disabled: Closed Default value: Enabled

5.2.10 PCI Subsystem Settings

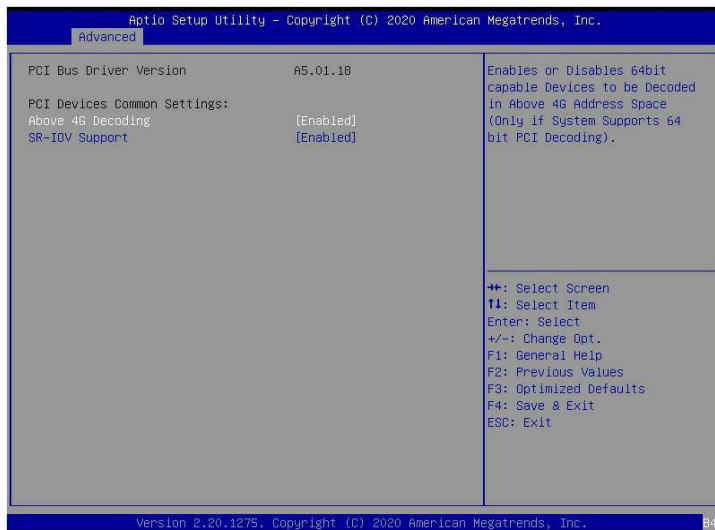

Figure 5- 9

Above 4G Decoding

Memory space resource decoding control switch above 4G, the menu options are:

- Enabled: open
- Disabled: Closed Default value: Enabled

SR-IOV Support

SR-IOV supports switch settings, the menu options are:

- Enabled: open
- Disabled: Closed Default value: Enabled

5.2.11 CSM Configuration

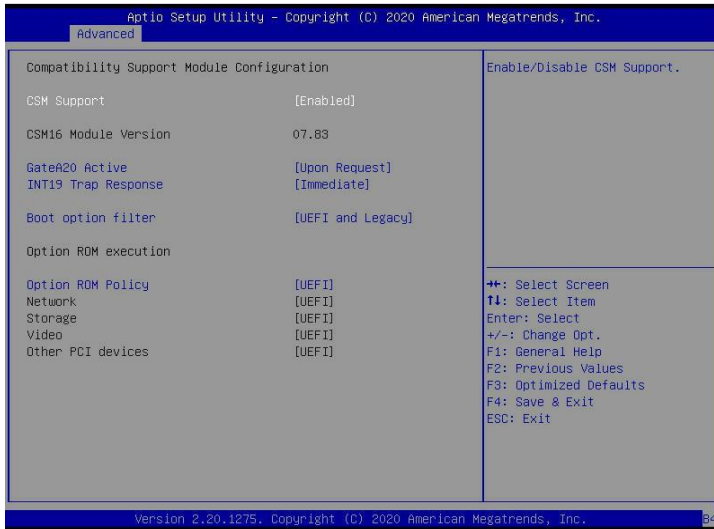

Figure 5- 10

CSM Support

To enable or disable the compatible support module, the menu options are:

- Disabled: shut down
- Enabled: Open Default value: Enabled

GateA20 Active

A20 address line control mode setting, the menu options are:

- Upon Request: If needed
- Always: always

Default value: Upon Request

INT19 Trap Response

Interrupt and capture signal response settings, the menu options are:

- Immediate: Respond immediately
- Postponed: Delayed response

Default value: Immediate

Boot option filter

Start option control switch, the menu options are:

- UEFI and Legacy: UEFI and Legacy startup items
- UEFI only: UEFI boot item
- Legacy only: Legacy boot item Default value: UEFI and Legacy

Option ROM Policy

Select Option ROM execution mode, the menu options are:

- UEFI: UEFI mode
- Legacy: Legacy mode Default value: UEFI

5.2.12 NVMe Configuration



Figure 5- 11

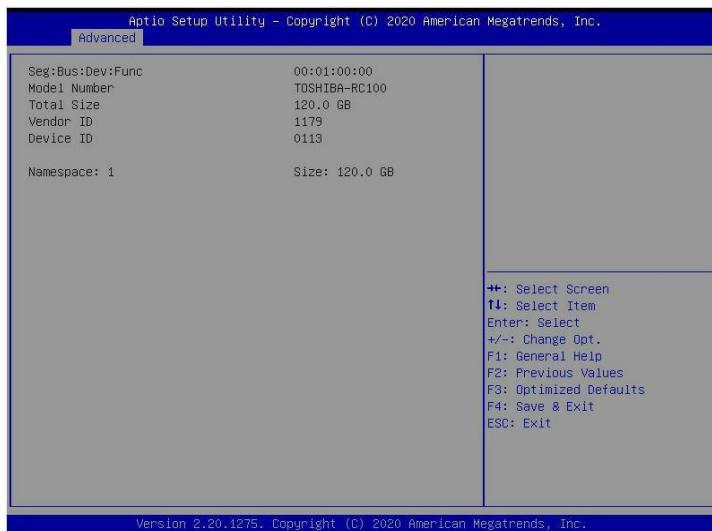

Figure 5- 12

Display the detailed information of the NVMe hard disk.

5.2.13 Network Stack Configuration

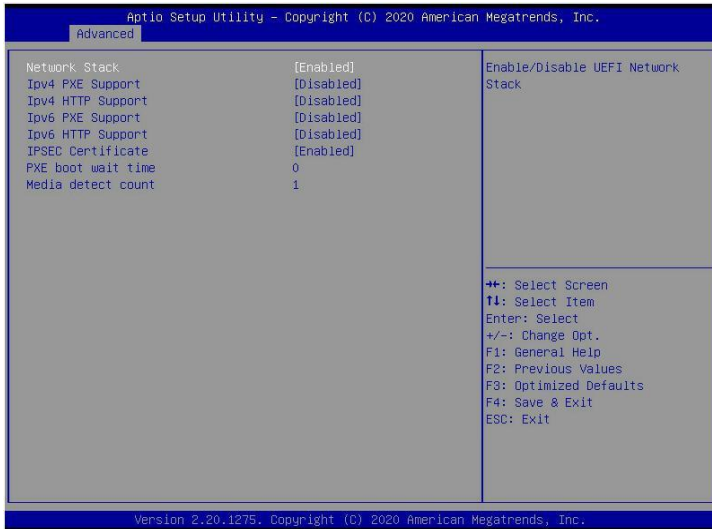

Figure 5- 13

Network Stack

Network stack control switch, the menu options are:

- Enabled: open
- Disabled: Closed Default value: Disabled

Ipv4 PXE Support

Ipv4 UEFI PXE function control switch, the menu options are:

- Enabled: open
- Disabled: Closed Default value: Disabled

Ipv4 HTTP Support

Ipv4 HTTP function control switch, the menu options are:

- Enabled: open
- Disabled: Closed Default value: Disabled

Ipv6 PXE Support

Ipv6 UEFI PXE function control switch, the menu options are:

- Enabled: open
- Disabled: Closed Default value: Disabled

Ipv6 HTTP Support

Ipv6 HTTP function control switch, the menu options are:

- Enabled: open
- Disabled: Closed Default value: Disabled

PXE boot wait time

PXE startup waiting time, the user can enter the PXE startup waiting time, the waiting process can press "ESC"

Give up PXE boot, the default is 0.

Media detect count

The number of device detection times, the user can enter the number of device network card device detection times, the default is 1.

5.2.14 iSCSI Configuration

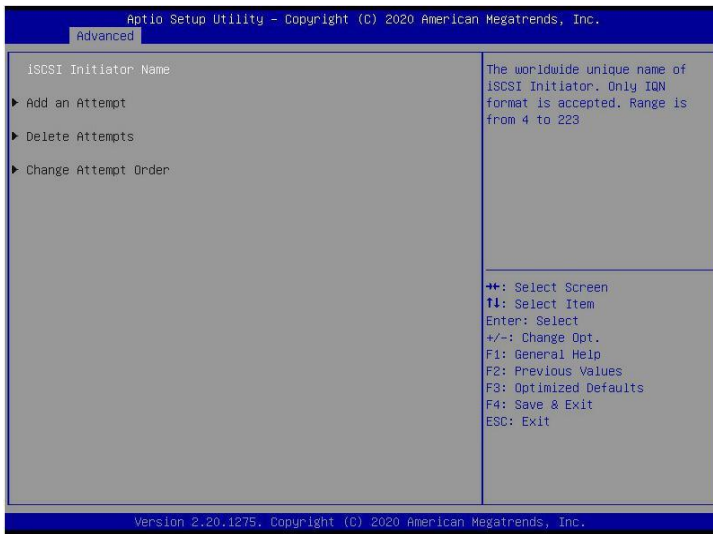

Figure 5- 14

iSCSI configuration

5.2.15 Platform Configuration menu

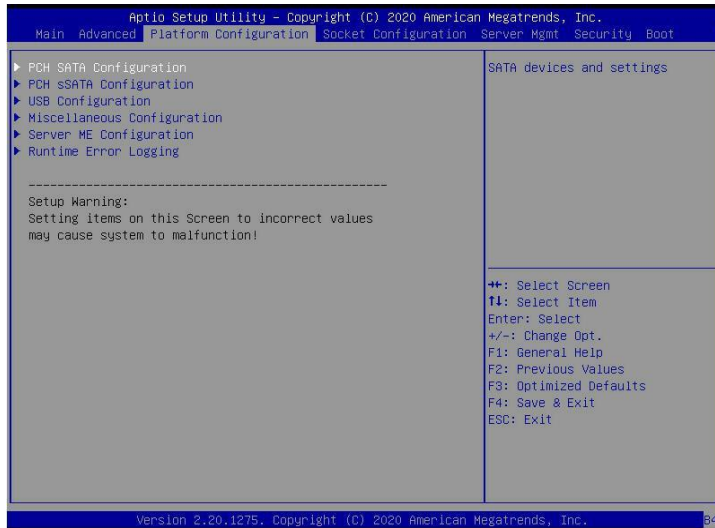

Figure 5- 15

- PCH SATA Configuration PCH SATA related configuration;
- PCH sSATA Configuration PCH sSATA related configuration;
- USB Configuration USB related configuration.
- Miscellaneous Configuration other related configuration;
- Server ME Configuration Server ME Configuration;
- Runtime Error Logging

Runtime error log.

5.2.16 PCH SATA Configuration

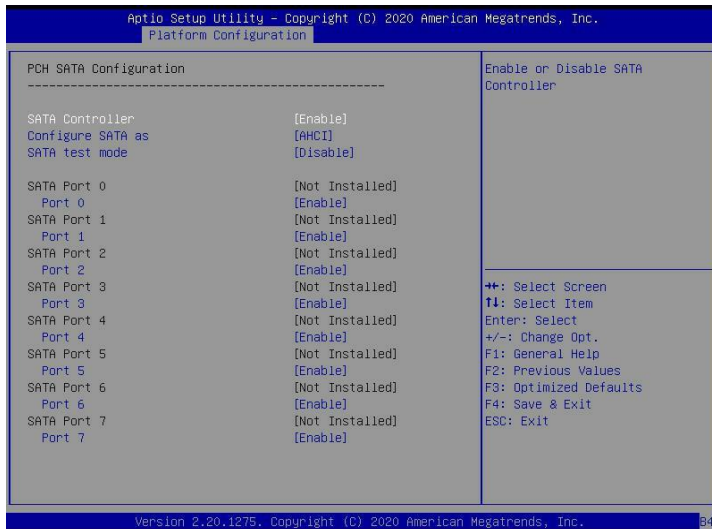

Figure 5- 16

SATA Controller

SATA controller switch, control to turn on and off the SATA controller, the menu options are:

- Disabled: Turn off the SATA controller.
- Enabled: Turn on the SATA controller. Default value: Enabled

Configure SATA as

SATA mode selection, the menu options are:

- AHCI: Select SATA mode as AHCI mode.
- RAID: Select SATA mode as RAID mode. Default value: AHCI

SATA test mode

SATA test mode switch, the menu options are:

- Disable: Turn off.
- Enable: Turn on. Default value: Disable

SATA Port X

Display device information on SATA Port 0~7, and display Not Installed when the device is not connected.

Port X

Control the opening and closing of SATA Port X, the menu options are:

- Disabled: Close SATA Port X.
- Enabled: Enable SATA Port X. Default value: Enabled

Hot Plug

Control the hot plug function of SATA Port X device on and off, the menu options are:

- Disabled: Disable the hot plug function of SATA Port X.
- Enabled: Enable SATA Port X hot plug function. Default value: Enabled

5.2.17 PCH sSATA Configuration

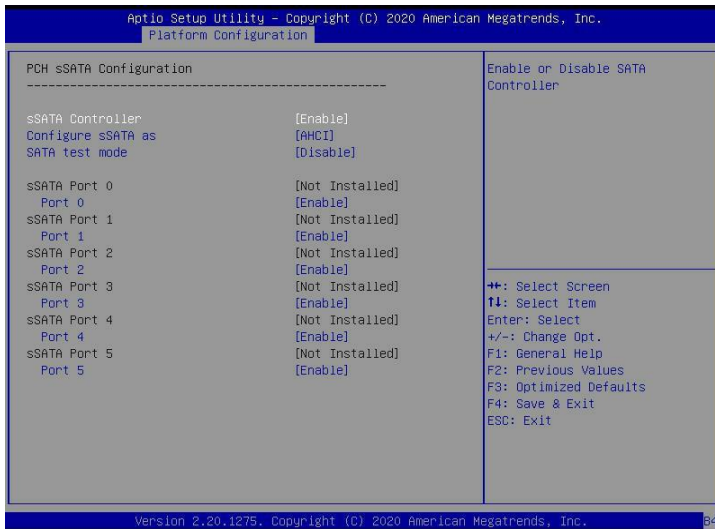

Figure 5- 17

sSATA Controller

sSATA controller switch, control to turn on and off the sSATA controller, the menu options are:

- Disabled: Turn off the sSATA controller.
- Enabled: Turn on the sSATA controller. Default value: Enabled

Configure sSATA as

sSATA mode selection, the menu options are:

- AHCI: Select sSATA mode as AHCI mode.
- RAID: Select sSATA mode as RAID mode. Default value: AHCI

SATA test mode

SATA test mode switch, the menu options are:

- Disable: Turn off.
- Enable: Turn on.

Default value: Disable

sSATA Port X

Display the device information on sSATA Port 0~7, and display Not Installed when the device is not connected.

Port X

To control the opening and closing of sSATA Port X, the menu options are:

- Disabled: Close sSATA Port X.
- Enabled: Enable sSATA Port X. Default value: Enabled

5.2.18 USB Configuration

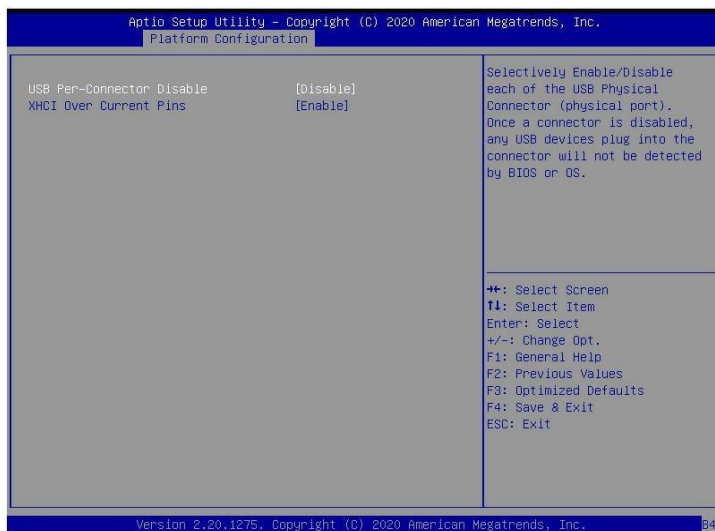

Figure 5- 18

USB Per-Connector Disable

Each USB connector switch, the menu options are:

- Enable: open
- Disable: Turn off Default value: Disable

XHCI Over Current Pins

XHCI overcurrent pin switch, the menu options are:

- Enable: open
- Disable: Turn off Default value: Enable

5.2.19 Miscellaneous Configuration

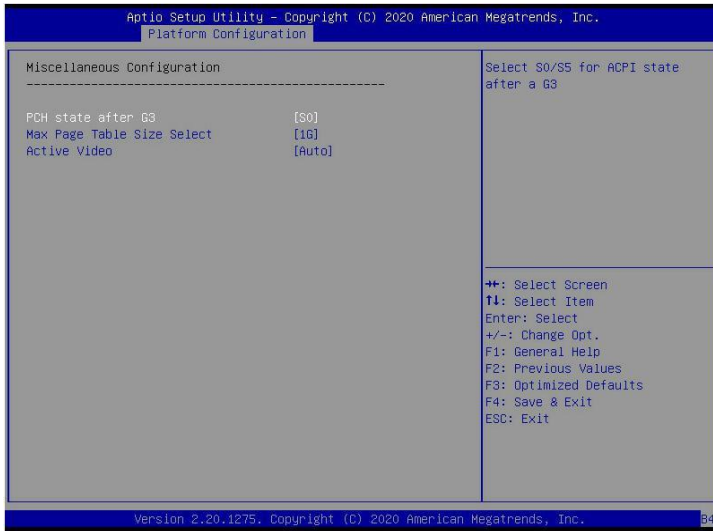

Figure 5- 19

PCH state after G3

PCH status setting after G3, the menu options are:

- S0: Power on directly
- S5: You need to press the Power button to power on
- leave power state unchanged: leave power state unchanged
- Default value: S0

Max Page Table Size Select

Select the maximum page table size setting, the menu options are:

- 2M
- 1G

Default value: 1G

Active Video

Select the active display device type, the menu options are:

- Auto: automatic
- Onboard Device: Onboard device
- PCIE Device: PCIE device Default value: Auto

5.2.20 Server ME Configuration

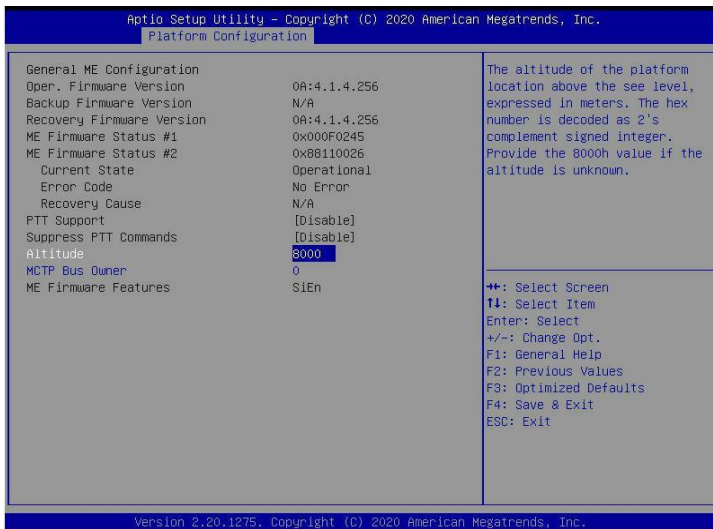

Figure 5- 20

Display Server ME version, features, status and other information;

5.2.21 Runtime Error Logging

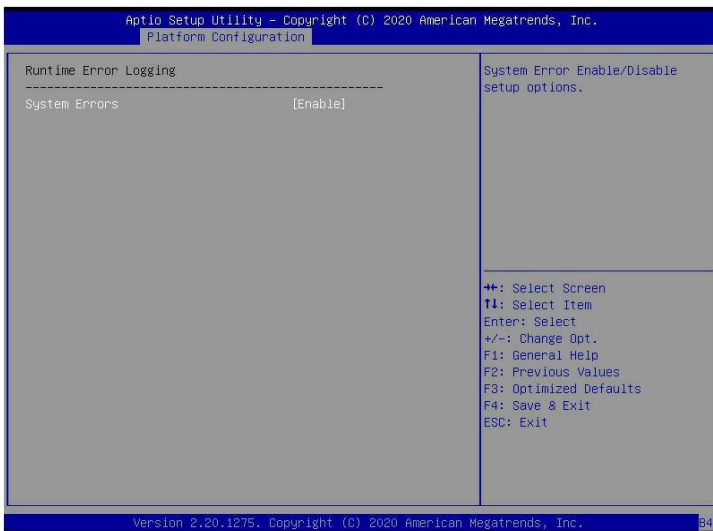

Figure 5- 21

System Errors

Turn on or off the system error function, the menu options are:

- Disabled: shut down
- Enabled: Open Default value: Enabled

5.2.22 Socket Configuration menu

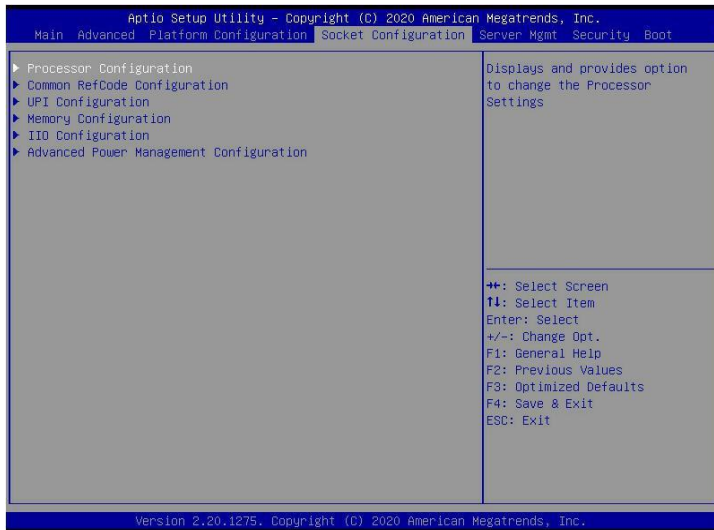

Figure 5- 22

- Processor Configuration processor related configuration;
- Common RefCode Configuration Common RefCode configuration;
- UPI Configuration UPI configuration;
- Memory Configuration memory configuration;
- IIO Configuration IIO configuration;
- Advanced Power Management Configuration

5.2.23 Processor Configuration

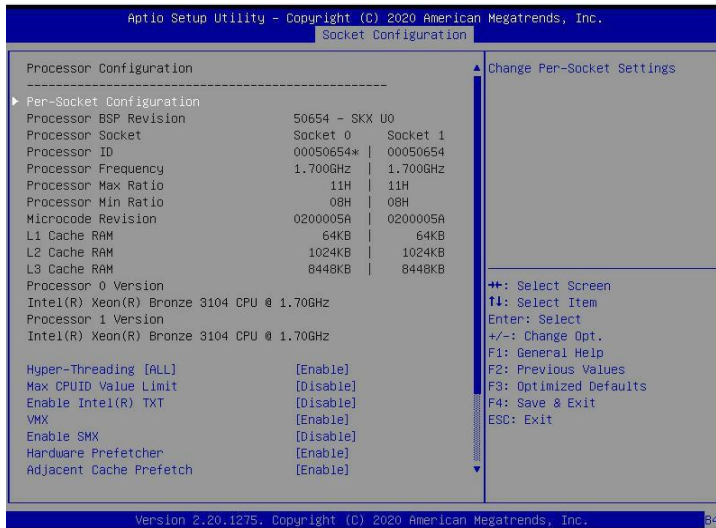

Figure 5- 23

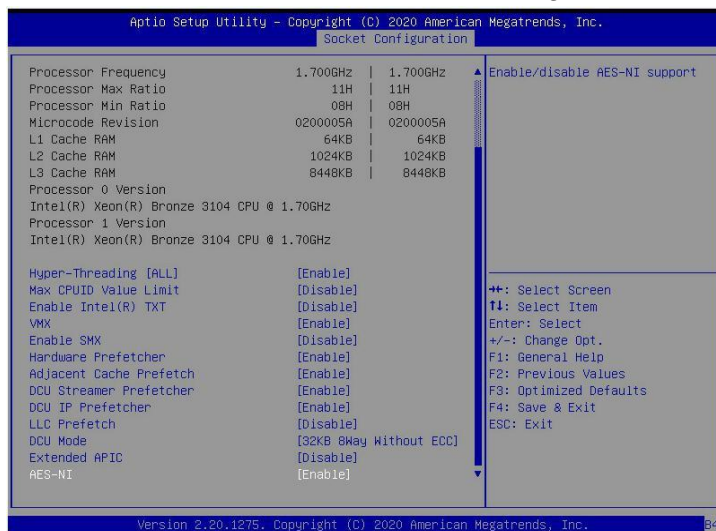

Figure 5- 24

Display CPU Type\ID\Speed\Cache and other information, configure CPU related functions;

- Pre-Socket Configuration: each slot configuration; Hyper-Threading

Hyper-threading control switch, this option can enable or disable the Intel processor hyper-threading function. Enable this

Function, each physical processor core is equivalent to two logical processor cores; disable this function, each physical processor core is equivalent to only one logical processor core. Enabling this feature will bring a higher processor core count and improve the overall performance of the application. The menu options are:

- Enable: open
- Disable: Turn off Default value: Enable

Max CPUID Value Limit

When starting a traditional operating system that cannot support extended CPUID, the menu options are:

- Enable: open
- Disable: Turn off Default value: Disable

Enable Intel(R) TXT

Intel TXT function switch, the menu options are:

- Enable: open
- Disable: Turn off Default value: Disable

VMX

CPU virtualization technology switch, enable this option, then the virtualization layer or operating system that

supports this option can use the hardware capabilities of Intel virtualization technology. Some virtualization layers require Intel virtualization technology to be enabled. Do not use the virtualization layer or operating system that supports this option, and you can also keep this option enabled. The menu options are:

- Enable: open
- Disable: Close
- Default value: Enable

Enable SMX

Extended safe mode function switch, the menu options are:

- Enable: open
- Disable: Turn off Default value: Disable

Hardware Prefetcher

Hardware prefetching means that before the CPU processes instructions or data, it prefetches these instructions or data from the memory to the L2 cache, thereby reducing the time of memory reading, helping to eliminate potential bottlenecks, and improving system performance. The menu options are:

- Enable: open
- Disable: Turn off Default value: Enable

Adjacent Cache Prefetch

After the adjacent cache prefetch function is turned on, when the computer reads the data, it will intelligently think that the data next to or adjacent to the data to be read is also needed, so it will read the adjacent data in advance during processing. , This can speed up the reading speed. When the application scenario is to access memory sequentially, enabling this feature will improve performance. When the application scenario is random access to memory, it is recommended to disable this option. The menu options are:

- Enable: open
- Disable: Turn off Default value: Enable

DCU Streamer Prefetcher

DCU stream prefetch switch, the menu options are:

- Enable: open
- Disable: Turn off Default value: Enable

DCU IP Prefetcher

DCU IP prefetch switch, the menu options are:

- Enable: open
- Disable: Turn off Default value: Enable

LLC Prefetcher

LLC prefetch switch, the menu options are:

- Enable: open
- Disable: Turn off Default value: Disable

DCU Mode

DCU mode setting, the menu options are:

- 32KB 8Way Without ECC: 32KB 8Way Without ECC
- 16KB 4Way With ECC: 16KB 4Way With ECC Default value: 32KB 8Way Without ECC

Extended APIC

Enable/disable extended APIC support, the menu options are:

- Enable: open
- Disable: Turn off Default value: Disable

AES-NI

Turn AES (Advanced Encryption Standard) on and off, the menu options are:

- Enable: open
- Disable: Turn off Default value: Enable

5.2.24 Common RefCode Configuration

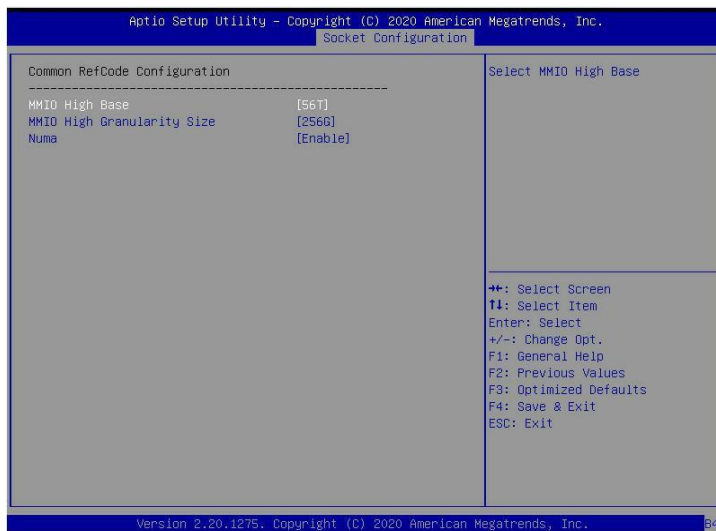

Figure 5- 25

MMIO High Base

Select MMIO high base address, the menu options are:

- 56T
- 40T
- 24T
- 16T
- 4T
- 1T

Default value: 56T

MMIO High Granularity Size

Select MMIO high interval size, the menu options are:

- 1G
- 4G
- 16G
- 64G
- 256G
- 1024G

Default value: 256G

Numa

To turn on or off non-uniform memory access, the menu options are:

- Enable: open
- Disable: Turn off Default value: Enable

5.2.25 UPI Configuration

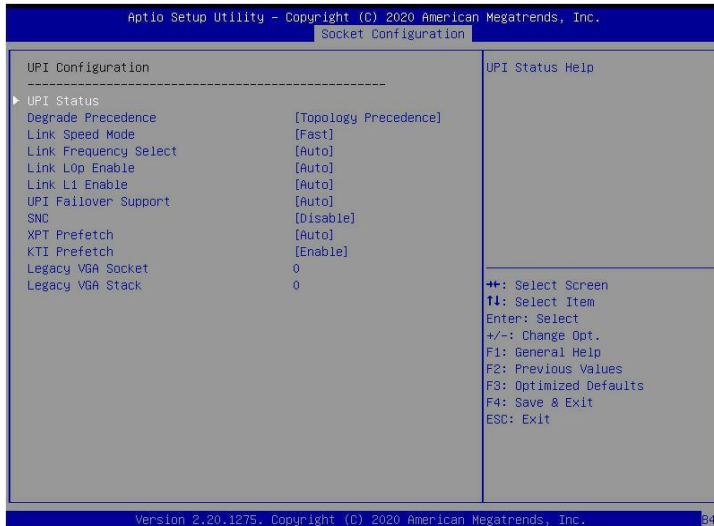

Figure 5- 26

- UPI Status: UPI link status submenu, which displays the current UPI link status

Degrade Precedence

When the system settings conflict, you can reduce the feature by setting Topology Precedence, or you can reduce the Topology by setting Feature Precedence, the menu options are:

- Topology Precedence: Topology first
- Feature Precedence: Feature priority default value: Topology Precedence

Link Speed Mode

Link speed mode setting, the menu options are:

- Slow: slow
- Fast: Fast default value: Fast

Link L0p Enable

Link L0p switch, the menu options are:

- Disable : shut down
- Enable : Open open
- Auto : Automatic default value: Auto

Link L1 Enable

Link L1 switch, the menu options are:

- Disable : shut down
- Enable : Open open
- Auto : Automatic default value: Auto

UPI Failover Support

UPI failover supports switch settings, the menu options are:

- Disable : shut down
- Enable : Open open
- Auto : Automatic default value: Auto

SNC

Sub NUMA cluster settings, the menu options are:

- Disable : shut down
- Enable : Open open
- Auto : Automatic

Default value: Disable

XPT Prefetch

XPT prefetch settings, the menu options are:

- Disable : shut down
- Enable : Open open
- Auto : Automatic default value: Auto

KTI Prefetch

KTI prefetch settings, the menu options are:

- Disable : shut down
- Enable : Open open
- Auto : Automatic default value: Enable

- Legacy VGA Socket : Traditional VGA number setting, effective value range 0~1.

- Legacy VGA Stack : The number of traditional VGA stacks is set, and the effective value range is 0~6.

5.2.26 Memory Configuration

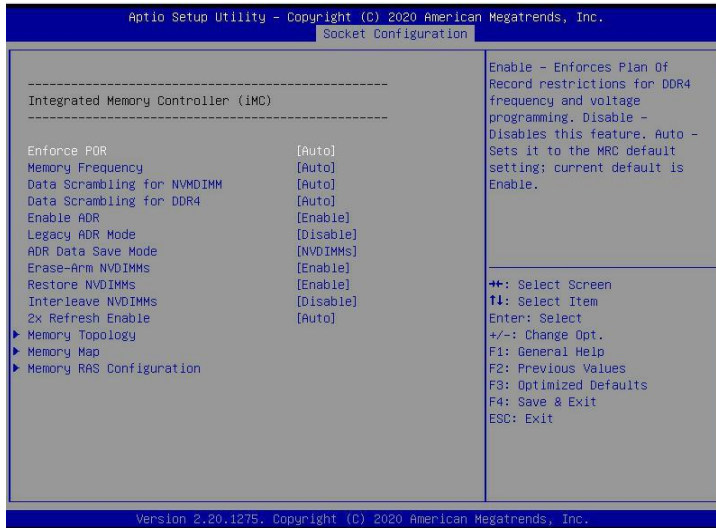

Figure 5- 27

Enforce POR

To enforce POR settings, the menu options are:

- Auto : Automatic
- POR : Perform POR
- Disable : Off Default value: Auto

Memory Frequency

Memory frequency setting, the menu options are:

- Auto : Automatic
- 800
- 1000
- 1066
- 1200
- 1333
- 1400
- 1600

Default value: Auto

Data Scrambling for NVDIMM

NVDIMM data scramble switch setting, the menu options are:

- Auto : Automatic
- Disable : shut down
- Enable : Open the default value: Auto

Data Scrambling for DDR4

DDR4 data scramble switch setting, the menu options are:

- Auto : Automatic
- Disable : shut down
- Enable : Open the default value: Auto

Enable ADR

ADR enable switch setting, the menu options are:

- Disable : shut down
- Enable : Open the default value: Enable

Legacy ADR Mode

Traditional ADR mode switch settings, the menu options are:

- Disable : shut down
- Enable : Open the default value: Enable

ADR Data Save Mode

ADR data saving mode setting, the menu options are:

- Disable : shut down
- Batterybacked DIMMs
- NVDIMMs

Default value: NVDIMMs

Erase-ARM NVDIMMs

Erase-ARM NVDIMMs switch setting, the menu options are:

- Disable : shut down
- Enable : Open the default value: Enable

Restore NVDIMMs

Fix the switch settings of NVDIMMs, the menu options are:

- Disable : shut down
- Enable : turn on
- Auto : Automatic default value: Auto

Interleave NVDIMMs

Interleaved NVDIMMs switch settings, the menu options are:

- Disable : shut down
- Enable : Open the default value: Disable

2x Refresh Enable

2x refresh switch settings, the menu options are:

- Disable : shut down
- Enable : Open the default value: Disable

Memory Topology

Memory topology sub-menu, showing detailed information of the in-place memory;

Memory Map

Memory Map submenu;

Memory RAS Configuration memory RAS configuration submenu;

5.2.27 Memory Topology

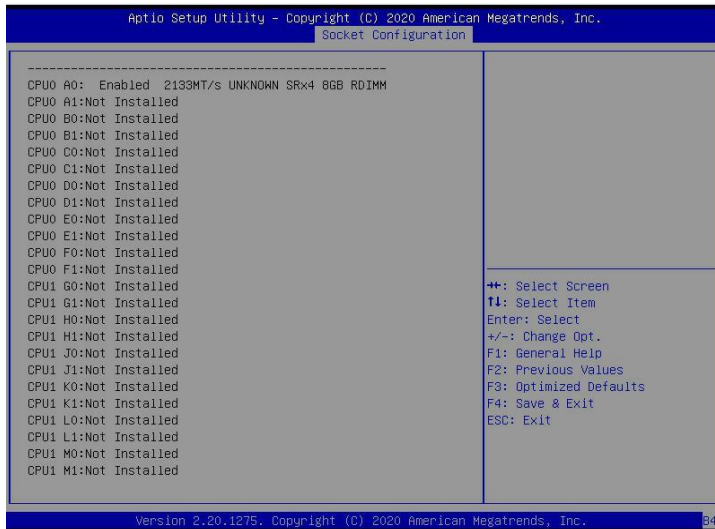

Figure 5- 28

Display the detailed information of the current memory

5.2.28 Memory Map

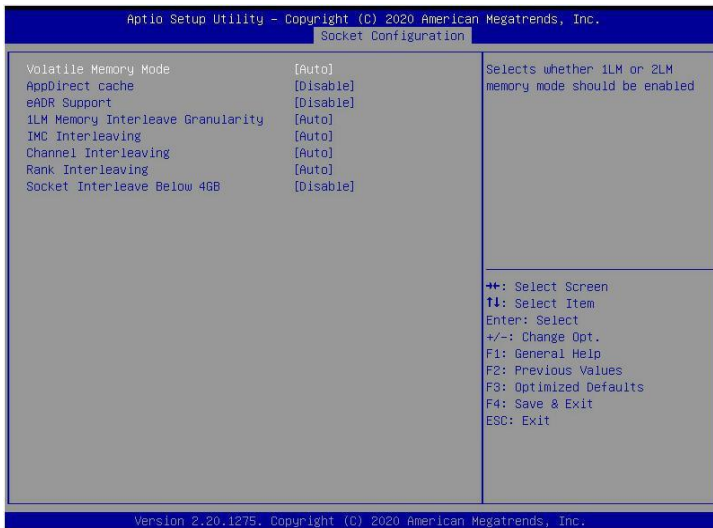

Figure 5- 29

Volatile Memory Mode

Volatile memory mode setting, the menu options are:

- 1LM
- 2LM
- Auto

Default value: Auto

1LM Memory Interleave Granularity 1LM Memory Interleave Granularity setting, the menu options are:

- Auto
- 256B Target, 256B Channel
- 64B Target, 64B Channel Default Value: Auto

IMC Interleaving

IMC cross setting, the menu options are:

Auto

- 1-way Interleavel
- 2-way Interleavel Default Value: Auto

Channel Interleaving

Channel cross setting, the menu options are:

- Auto
- 1-way Interleavel
- 2-way Interleavel
- 3-way Interleavel Default Value: Auto

Rank Interleaving

Rank cross setting, the menu options are:

- Auto
- 1-way Interleavel
- 2-way Interleavel
- 4-way Interleavel
- 8-way Interleavel Default Value: Auto

Socket Interleave Below 4GB

The processor interleave switch setting for the address space below 4GB, the menu options are:

- Enable : turn on
- Disable : Default value: Disable

5.2.29 Memory RAS Configuration

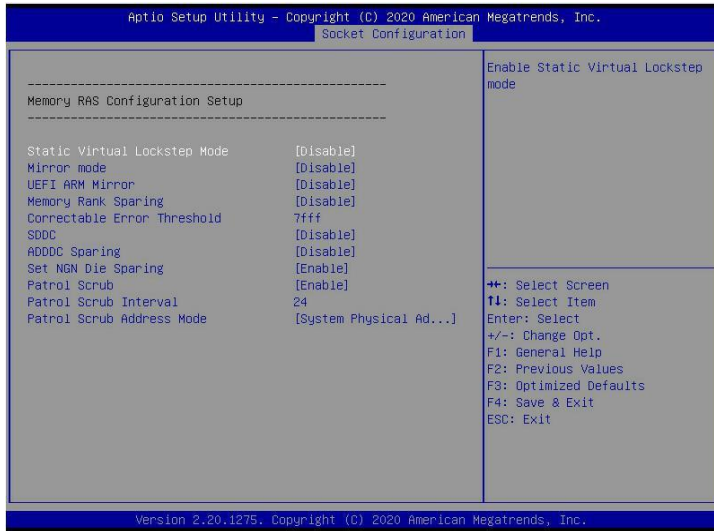

Figure 5- 30

Static Virtual Lockstep Mode

Static virtual Lockstep mode switch setting, the menu options are:

- Enable : turn on
- Disable : Default value: Disable

Mirror Mode

Mirror mode setting, the menu options are:

- Disable : shut down
- Enable Mirror Mode (1LM) Default value: Disable

UEFI ARM Mirror

UEFI ARM mirroring mode switch setting, the menu options are:

- Enable : turn on
- Disable : shut down
- Default value: Disable

Memory Rank Sparing

Memory Rank hot backup switch setting, the menu options are:

- Enable : turn on
- Disable : Default value: Disable

Correctable Error Threshold : The error threshold can be corrected, the effective value is 0x01-0x7fff, and the default value is 0x7fff.

SDDC

SDDC switch setting, note: AEP DIMM is not supported when it exists, the menu options are:

- Enable : turn on
- Disable : Default value: Disable

ADDDC Sparing

ADDDC hot standby switch setting, the menu options are:

- Enable : turn on
- Disable : Default value: Disable

Set NGN Die Sparing

Set NGN Die hot backup switch settings, the menu options are:

- Enable : turn on
- Disable : Off Default value: Enable

Patrol Scrub

Patrol Scrub switch settings, the menu options are:

- Enable : turn on
- Disable : Off Default value: Enable

Patrol Scrub Interval : Patrol Scrub interval time setting, the unit is hour, the range is 1-24, the default value is 24.

Patrol Scrub Address Mode

Patrol Scrub address mode setting, the menu options are:

- Reverse address
- System Physical Address

Default value: System Physical Address

5.2.30 IIO Configuration

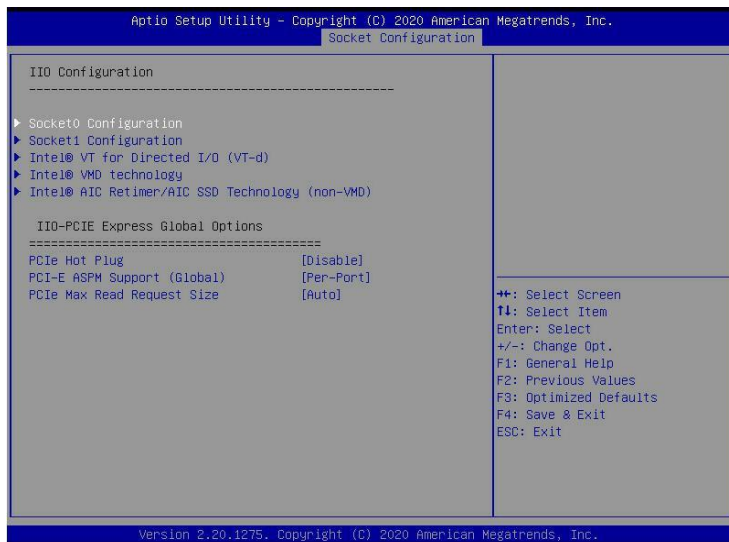

Figure 5- 31

Socket0 Configuration

The Socket0 configuration submenu is used to set the Link speed, Max Payload Size, ASPM and other settings of the device on the PCIE of CPU0, and display the link status of the current PCIE port. Maximum link, current link rate, etc.;

Intel(R) VT for Directed I/O(VT-d)

Intel VT-d technology related settings sub-menu, Intel VT-d technology switch settings;

Intel(R) VMD Technology

Intel VMD technology related settings sub-menu, VMD switch settings on each PStack of each CPU;

Intel(R) AIC Retimer/AIC SSD Technology(non-VMD) Intel AIC Retimer/AIC SSD technology related settings sub-menu, each CPU of each PStack on the AIC Retimer/AIC SSD technology switch settings.

PCIe Hot Plug

PCIe hot swap switch settings, the menu options are:

- Enable : turn on
- Disable : Default value: Disable

PCI-E ASPM Support(Global)

PCI-E ASPM master switch setting, the menu options are:

- Disable : shut down
- Per-Port: each port
- L1 Only: L1 only Default value: Per-Port

PCI-E Max Read Request Size

PCI-E maximum read request size setting, the menu options are:

- Auto
- 128B
- 256B
- 512B
- 1024B
- 2048B
- 4096B

Default value: Auto

5.2.31 Advanced Power Management Configuration

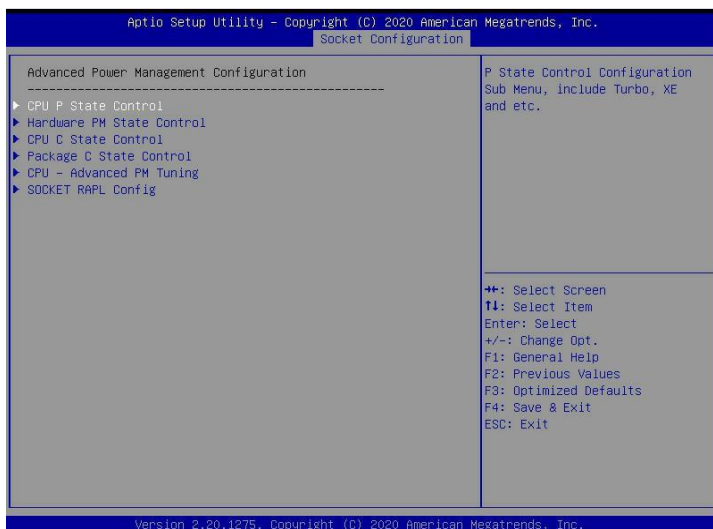

Figure 5- 32

CPU P State Control

CPU P status control setting submenu;

Hardware PM State Control hardware power management state control submenu;

CPU C State Control

CPU C status control setting submenu;

Package C State Control Package C state control submenu;

CPU-Advanced PM Tuning CPU performance and energy saving adjustment sub-menu;

Socket RAPL Configuration Socket RAPL configuration submenu;

5.2.32 CPU P State Control

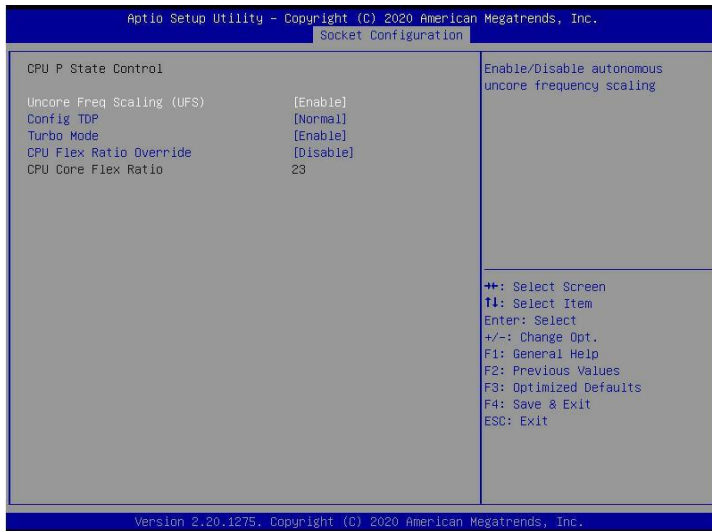

Figure 5- 33

Uncore Freq Scaling(UFS)

Uncore frequency extension setting, the menu options are:

- Enable : turn on
- Disable : Off Default value: Enable
- Config TDP

TDP level setting, the menu options are:

- Normal : Normal
- Level 1 : Level 1
- Level 2 : Level 2 Default value: Normal

Turbo Mode

Dynamic acceleration switch settings, the menu options are:

- Enable : turn on
- Disable : Off Default value: Enable

5.2.33 Hardware PM State Control

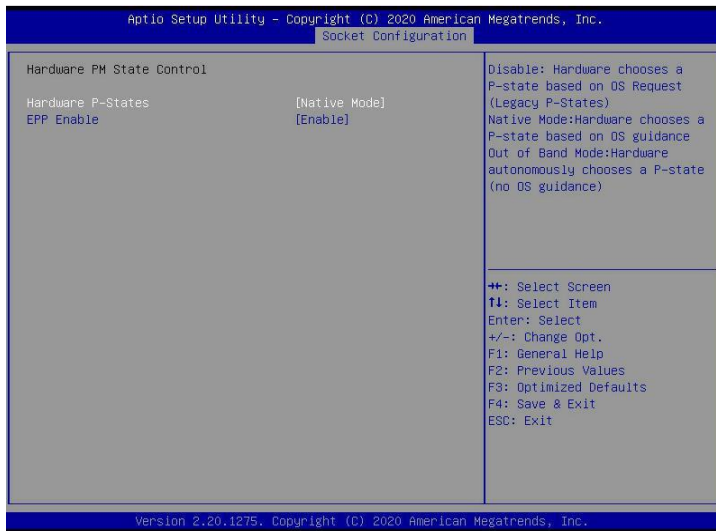

Figure 5- 34

Hardware P-State

The hardware chooses whether the P-State state is actively set by the OS, and the default value is determined according to the actual test.

The options are:

- Disable : Hardware selection P-States based on traditional OS request
- Native Mode: Hardware selection P-State is based on traditional OS boot
- Out of Band Mode: Automatic hardware selection, no OS boot required
- Native Mode with No Legacy Support Default Value: Native Mode

EPP Enable

EPP enable setting, the menu options are:

- Enable : turn on
- Disable : Off Default value: Enable

5.2.34 CPU C State Control

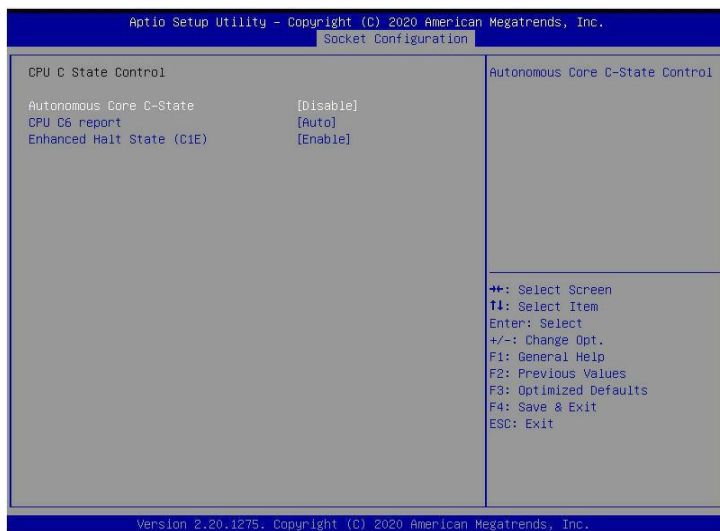

Figure 5-35

Autonomous Core C-State

Autonomous core C state switch settings, the menu options are:

- Enable : turn on
- Disable : Default value: Disable

CPU C6 report

Report the C6 status switch settings to the OS, the menu options are:

- Disable : shut down
- Enable : turn on
- Auto: Automatic default value: Auto

Enhanced Halt State(C1E) C1E switch setting, the menu options are:

- Disable : shut down
- Enable : Open the default value: Enable

5.2.35 Package C State Control

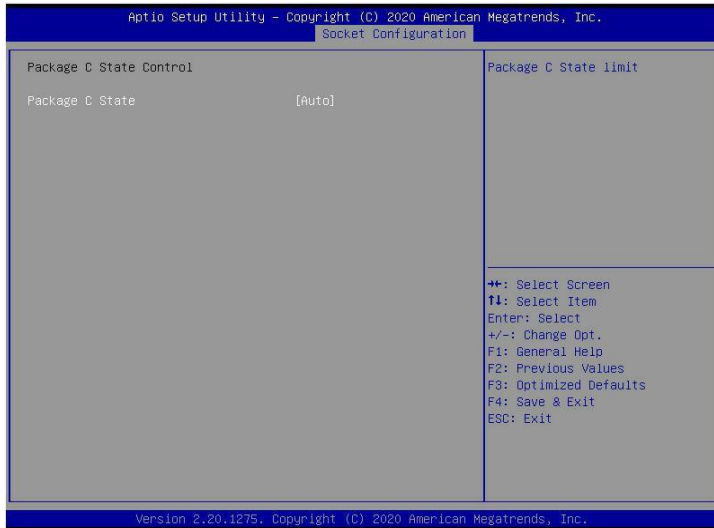

Figure 5- 36

Package C State

Package C status setting, the menu options are:

- C0/C1 state
- C2 state
- C6(non Retention) state
- C6(Retention) state
- No Limit

Default value: Auto

5.2.36 CPU-Advanced PM Tuning

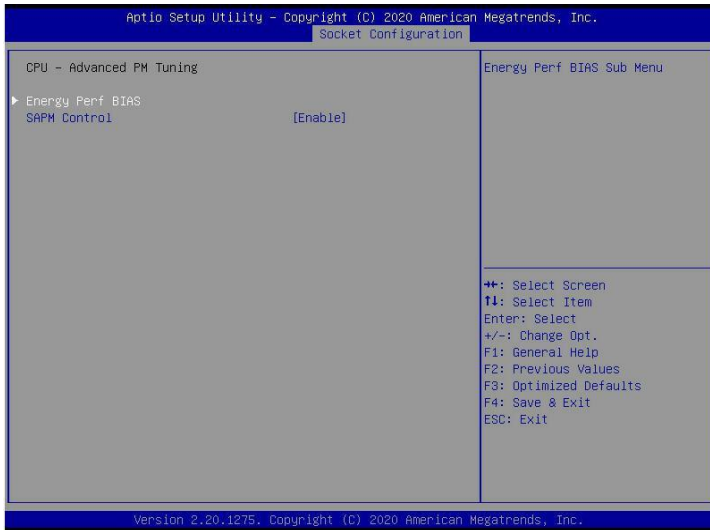

Figure 5- 37

Energy Perf BIAS

CPU power saving performance related option settings

5.2.37 Energy Perf BIAS



Figure 5- 38

Power Performance Tuning

Energy-saving performance adjustment settings, the menu options are:

- OS Controls EPB: OS control energy saving performance adjustment
 - BIOS Controls EPB: BIOS control energy saving performance adjustment
- default value: OS Controls EPB

ENERGY_PERF_BIAS_CFG Mode

Energy-saving performance management settings. This item can be set when Power Performance Tuning is set to BIOS Control EPB. The menu options are:

- Performance: Performance
- Balanced Performance: Balance performance
- Balanced Power: Balance energy saving
- Power: Energy saving

Default value: Balanced Performance

Workload Configuration

Optimize settings for workload characteristics, the menu options are:

- Balanced
- I/O Sensitive

Default value: Balanced

5.2.38 Server Mgmt menu

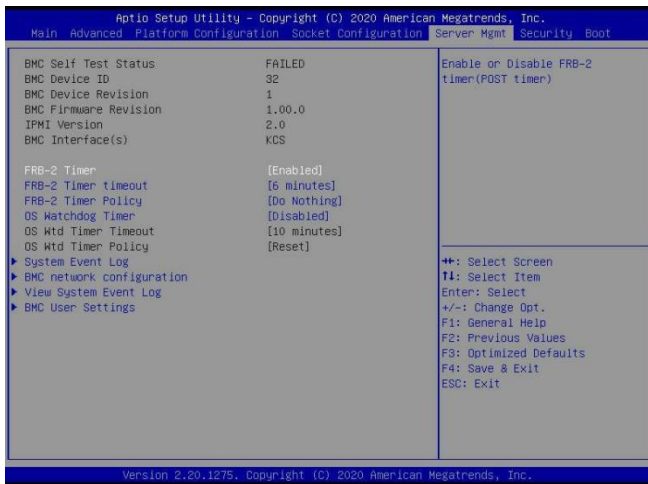

Figure 5-39

Display BMC self-check status, device ID, device version, BMC software version, and support IPMI specification version.

FRB-2 Timer

FRB-2 clock switch settings, the menu options are:

- Enabled : turn on
- Disabled : Off Default value: Enabled
- FRB-2 Timer timeout

FRB-2 clock timeout setting, the menu options are:

- 3 minutes
- 4 minutes
- 5 minutes
- 6 minutes

Default value: 6 minutes

FRB-2 Timer Policy

The policy setting after FRB-2 clock timeout, the menu options are:

- Do Nothing
- Reset
- Power Down
- Power Cycle

Default value: Do Nothing

OS Watchdog Timer

OS watchdog clock switch settings, the menu options are:

- Enabled : turn on
- Disabled : Default value: Disabled

OS Wtd Timer timeout

OS watchdog clock timeout setting, the menu options are:

- 5 minutes
- 10 minutes
- 15 minutes
- 20 minutes

Default value: 10 minutes

OS Wtd Timer Policy

The policy setting after the OS watchdog clock timeout, the menu options are:

Do Nothing

- Reset
- Power Down
- Power Cycle Default Value: Reset

- System Event Log Menu System Event Log Control Menu
- BMC network configuration menu BMC network configuration menu
- View System Event Log menu View system event log control menu
- BMC User Settings menu BMC User Settings menu

5.2.39 System Event Log menu

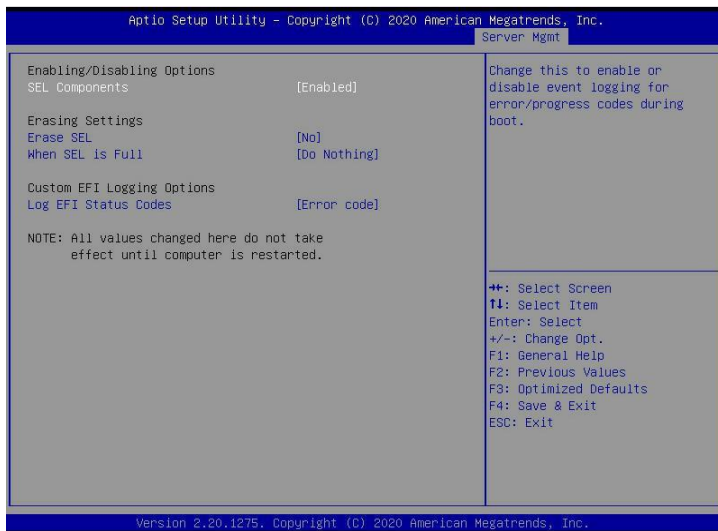

Figure 5- 40

SEL Components

System event recording function control switch during startup, menu options:

- Enabled: open
- Disabled: Closed Default value: Enabled

Erase SEL

Clear system event record control switch, menu options:

- No: do not clear
- Yes, On next reset: reset next time
- Yes, On every reset: Clear every restart Default value: No

When SEL is Full

When the system event record storage space is full, operate the control switch and menu options:

- Do Nothing: do not operate
- Erase Immediately: Erase Immediately Default value: Do Nothing

Log EFI Status Codes

Configuration record EFI Status Codes, menu options:

- Disabled: do not record
- Both: Record Error code & Progress code
- Error code: Only record Error code
- Progress code: Only record Progress code Default value: Error code

5.2.40 BMC network configuration menu

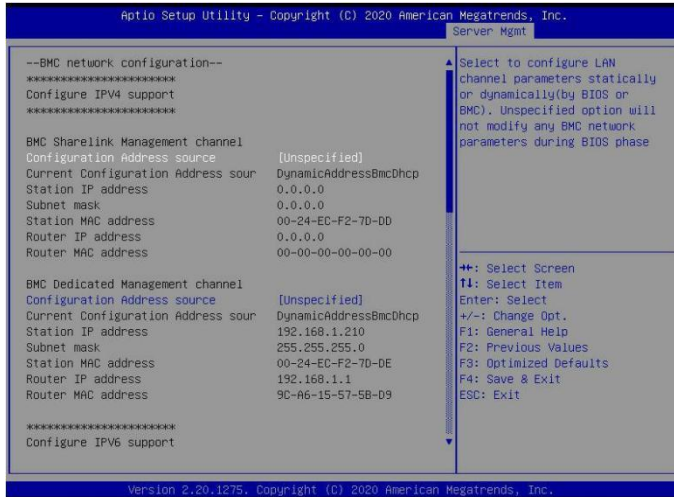

Figure 5- 41

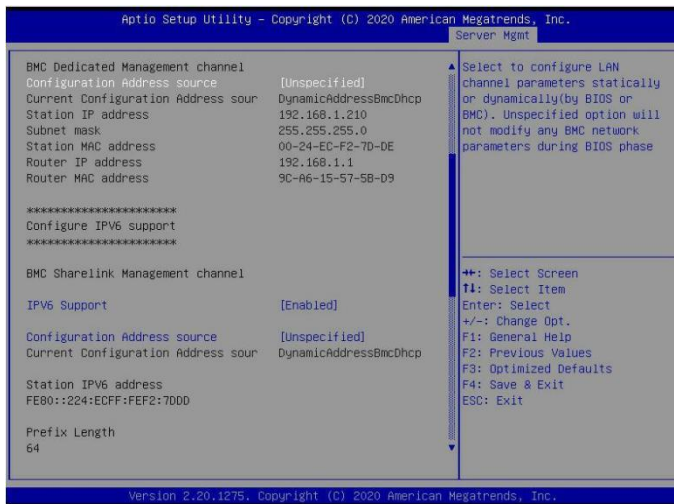

Figure 5- 42

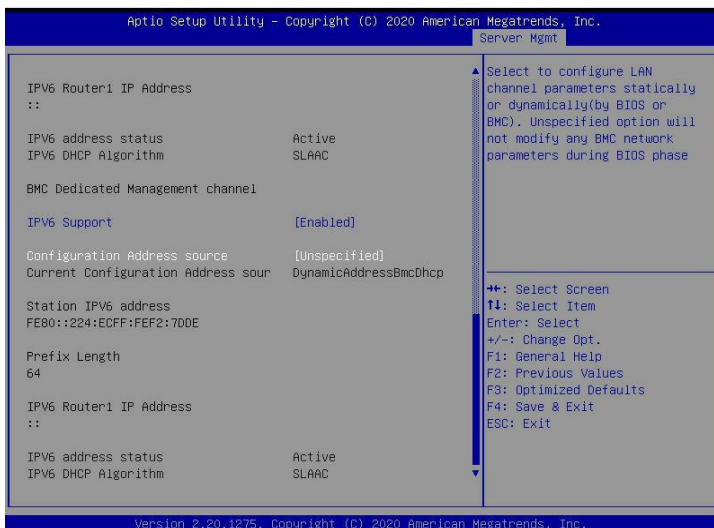

Figure 5- 43

Configure IPV4 support

BMC sharelink Management Channel Configuration Address source

Configure the BMC IP address allocation mode, the menu options are:

- Unspecified: Do not change BMC parameters
- Static: BIOS static IP setting
- DynamicBmcDhcp: BMC runs DHCP to dynamically allocate IP
- DynamicBmcNonDhcp: BMC runs Non-DHCP protocol to dynamically allocate IP Default value:

Unspecified



Modify from Unspecified to other parameters, save and restart after execution, the option will restore the Unspecified value,

There is no need to configure the BMC IP every time you start the process.

When the Configuration Address source option is Unspecified, the network parameter information (IPV4) of the system's shared network port will be displayed, the current IP configuration method, BMC IP, subnet mask, MAC address, routing IP, routing MAC;

BMC Dedicated Management Channel

Configuration Address source

Configure the BMC IP address allocation mode, the menu options are:

- Unspecified: Do not change BMC parameters
- Static: BIOS static IP setting
- DynamicBmcDhcp: BMC runs DHCP to dynamically allocate IP
- DynamicBmcNonDhcp: BMC runs Non-DHCP protocol to dynamically allocate IP Default value: Unspecified



Modify from Unspecified to other parameters, save and restart after execution, the option will restore the Unspecified value,

There is no need to configure the BMC IP every time you start the process.

When the Configuration Address source option is Unspecified, the network parameter information (IPV4) of the system's dedicated network port will be displayed, the current IP configuration method, BMC IP, subnet mask, MAC address, routing IP, routing MAC;

Configure IPV6 support

BMC Sharelink Management Channel IPV6 Support

Choose whether to support IPV6, the menu options are:

- Enabeld: Support IPV6
- Disabled: IPV6 is not supported Default value: Enabeld



Modify from Unspecified to other parameters, save and restart after execution, the option will restore the Unspecified value,

There is no need to configure the BMC IP every time you start the process.

When the Configuration Address source option is Unspecified, the network parameter information (IPV6) of the system shared network port will be displayed;

BMC Dedicated Management Channel IPV6 Support

Choose whether to support IPV6, the menu options are:

- Enabeld: Support IPV6
- Disabled: IPV6 is not supported Default value: Enabeld



Modify from Unspecified to other parameters, save and restart after execution, the option will restore the Unspecified value,

There is no need to configure the BMC IP every time you start the process.

When the Configuration Address source option is Unspecified, the network parameter information (IPV6) of the system dedicated network port will be displayed;

5.2.41 View System Event Log menu

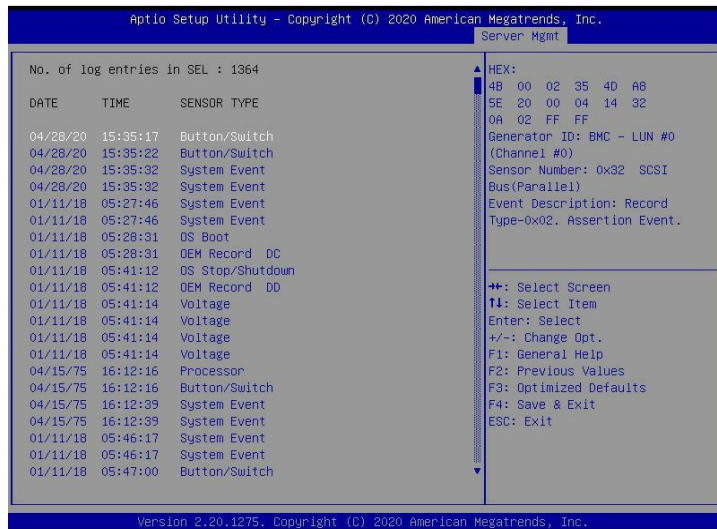

Figure 5- 44

View system event log
information.



Note that when entering this menu, BIOS needs to read the SEL data, and it takes a while.

5.2.42 BMC User Setting

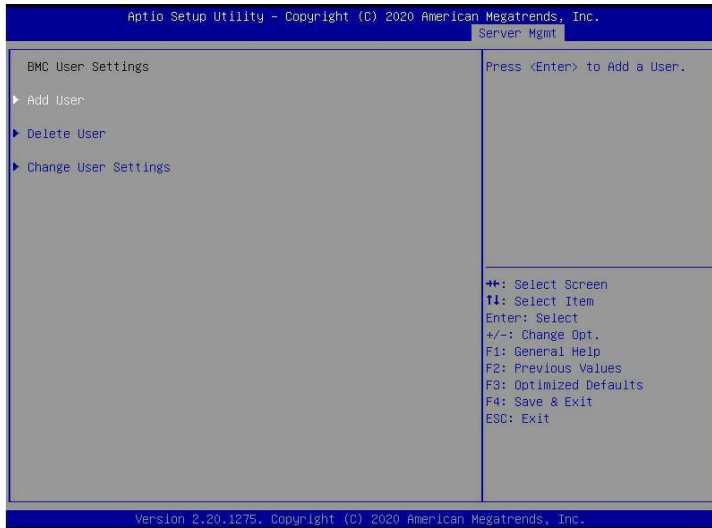

Figure 5- 45

- Add User

Add user submenu

- Delete User delete user submenu
- Change User Setting submenu

5.2.43 Add User

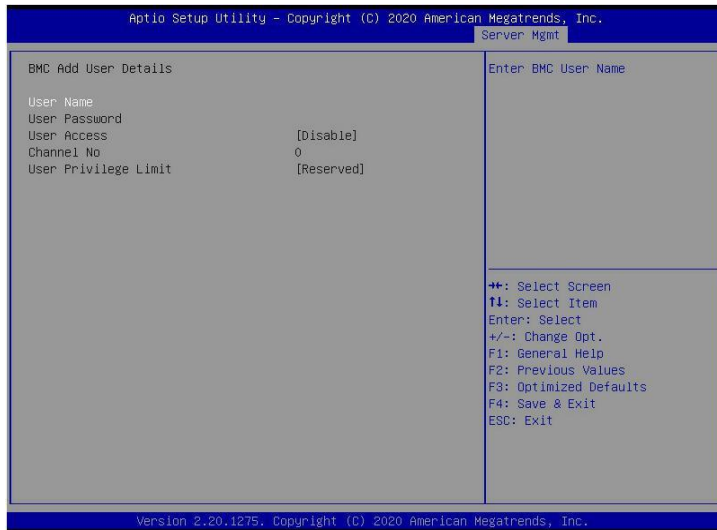

Figure 5- 46

User Name : User name setting, maximum support 16 characters.

User Password : User password setting, password characters must include uppercase and lowercase letters, special characters and numbers, with a minimum of 8 characters and a maximum of 20 characters.

Channel No : BMC channel setting, enter 1 or 8 User Privilege Limit

User permission settings, the menu options are:

- Reserved
- Callback
- User
- Operator
- Administrator

After the setting is successful, it will prompt "Set User Access Command Passed", and BMC User will take effect immediately.

5.2.44 Delete User

The screenshot shows a terminal window titled "Aptio Setup Utility - Copyright (C) 2020 American Megatrends, Inc." with a "Server Mgmt" menu. The main area is split into two columns. The left column is titled "BMC Delete User Details" and contains the labels "User Name" and "User Password". The right column is titled "Enter BMC User Name" and is currently empty. Below the right column is a list of keyboard shortcuts: "←→: Select Screen", "↑↓: Select Item", "Enter: Select", "+/-: Change Opt.", "F1: General Help", "F2: Previous Values", "F3: Optimized Defaults", "F4: Save & Exit", and "ESC: Exit". The footer of the window reads "Version 2.20.1275, Copyright (D) 2020 American Megatrends, Inc."

Figure 5- 47

User Name : Enter the name of the user to be deleted.

User Password : Enter the password of the user to be deleted. After entering the correct password, a prompt "User Delete!!!" will pop up. The successfully deleted user will immediately take effect in the BMC, and the user will not be able to log in to the BMC Web interface.

5.2.45 Change User Setting

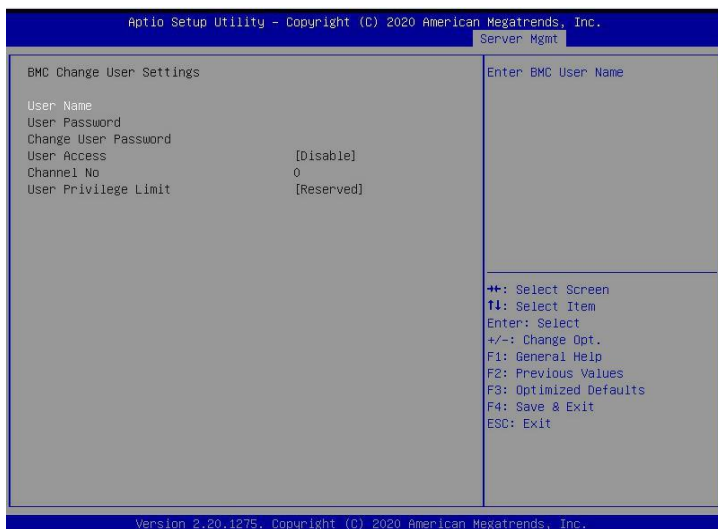

Figure 5- 48

User Name : Enter the user name to be modified.

User Password : Enter the user password to be modified. Only the name and password are entered correctly, the following options can be modified.

User

User permission switch settings, the menu options are:

- Enabled : turn on
- Disabled : Default value: Disabled

Change User Password : To modify the user password, the input password characters must include uppercase and lowercase letters, special characters and numbers, at least 8 characters, and maximum 20 characters.

Channel NO : BMC channel setting, input 1 or 8.

User Privilege Limit

Modify user permission settings, the menu options are:

- Reserved
- Callback
- User
- Operator
- Administrator

5.2.46 Security menu

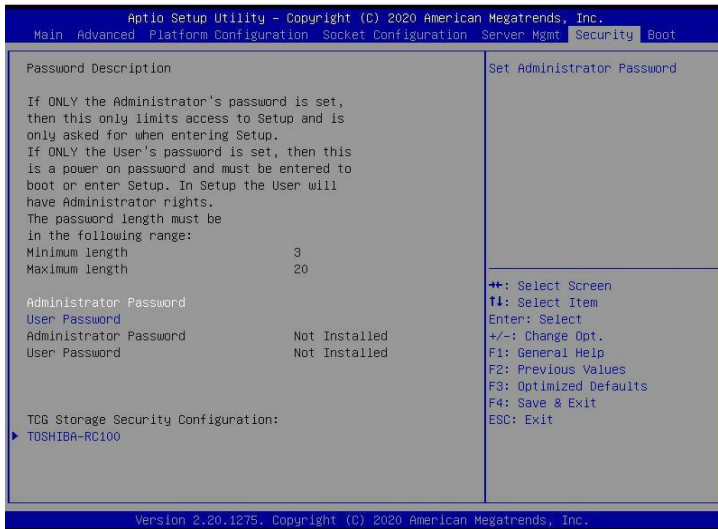

Figure 5-49

Administrator Password

Select this option to set the administrator password;

User Password

Select this option to set user password;

Administrator Password

Display the status of the administrator password, the system has an administrator password, displays Installed, there is no administrator

Password, display Not Installed;

User Password

Display the user password status, the system has a user password, and it displays Installed. If there is no user password, it displays Not Installed;

HDD Security Configuration

The hard disk list is displayed dynamically. The hard disks connected to the SATA and sSATA controllers will be displayed here. Enter the hard disk interface to set the hard disk password, and it will not display if there is no hard disk connected.

5.2.47 Boot menu

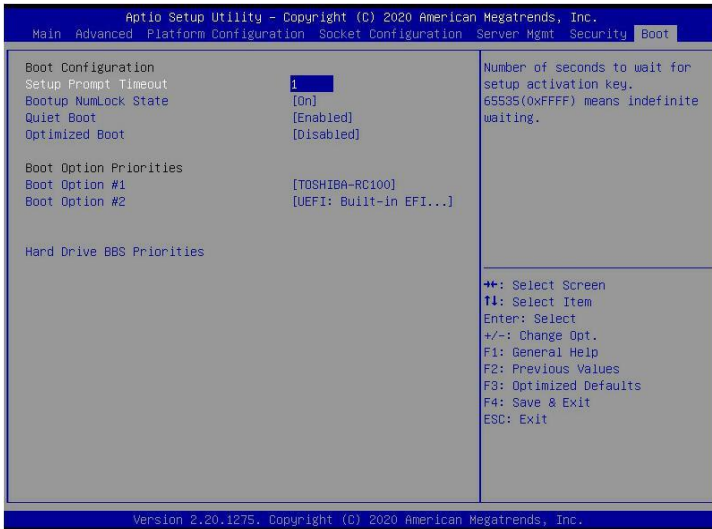

Figure 5- 50

Setup Prompt Timeout : Setup prompts timeout setting, set the time to wait for Setup to activate the key, the maximum value is 65535 seconds, and the default value is 1.

Bootup Numlock State

The keyboard Numlock indicator status switch setting during the startup process, the menu options are

- On : turn on
- OFF : Off Default value: On

Quiet Boot

Turn on and off the Quiet Boot function, the menu options are:

- Disabled: Turn off Quiet Boot, the POST message will be displayed at this time
- Enabled: Turn on Quiet Boot, and the OEM Logo will be displayed. Default value: Enabled

Optimized Boot

Turn on and off the Optimized Boot function, the menu options are:

- Disabled: Turn off Quiet Boot
- Enabled: Turn on Quiet Boot, and then disable Csm support and connect to network devices to reduce startup time

Default value: Disabled

Boot Option Priorities

Startup option list. This list is displayed dynamically and is determined by the number of startup options in the system. When there is no startup item, it is not displayed.

XXXX Driver BBS Priorities XXXX device BBS priority setting

5.2.48 Save & Exit menu

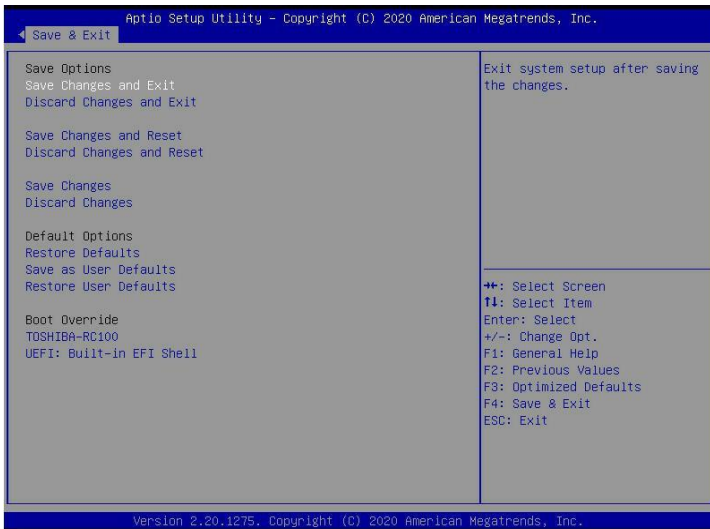

Figure 5-51

Save Changes and Exit

- Save the settings and exit the BIOS setup menu;

Discard Changes and Exit

- Give up saving the settings and exit the BIOS setup menu;

Save Changes and Reset save the settings and restart the system;

Discard Changes and Reset give up saving the settings and restart the system;

Save Changes to save the settings;

Discard Changes

- Give up saving settings;

Restore Defaults

- Load BIOS factory settings;

Save as user Defaults save as user default settings;

Restore user Defaults reload user default configuration;

Boot Override

- Startup options list, you can select startup options here.

5.3 User operation reminder

1.  With the option of, you need to understand the operating specifications in detail when you need to operate.
2. When operating options, please understand the meaning of the options in conjunction with the operating manual and the BIOS Setup interface option description.

Chapter 6 RAID Setting Instructions

6.1 PCH group RAID

6.1.1 Configure RAID in UEFI boot mode

➤ Operation before group raid

- a) During the server startup, press Delete/Esc as prompted to enter the BIOS Setup interface.
- b) Move to the PlatForm page -->PCH Configuration-->PCH SATA Configuration-->Configure SATA as. Configure SATA to RAID mode, as shown in Figure 6-1.

✧ Figure 6-1 Configure SATA to RAID mode:

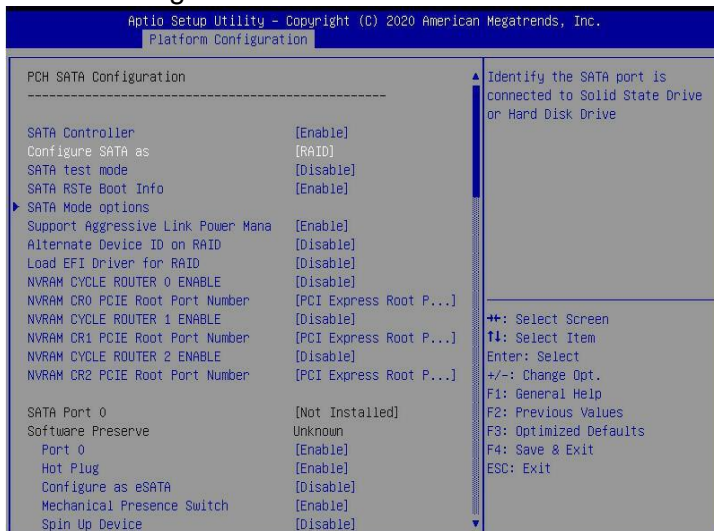

Figure 6-1

- c) Ensure that Storage and video in CSM Configuration are in UEFI mode, as shown in Figure 6-2

✧ Figure 6-2 Set Storage and Video to UEFI mode

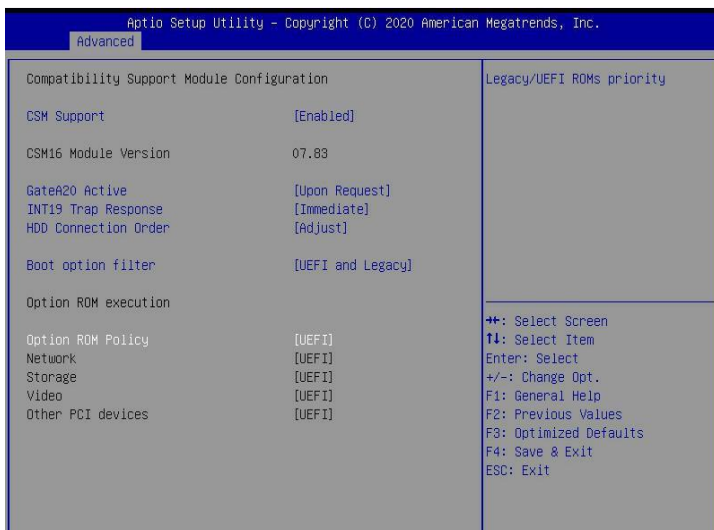

Figure 6-2

- d) Restart the server and enter the BIOS Setup interface, move to the Advanced page, you will see the intel(R) RSTe SATA Controller, press enter to enter the configuration RAID, as shown in Figure 6-3

❖ Figure 6-3 Intel RSTe SATA Controller

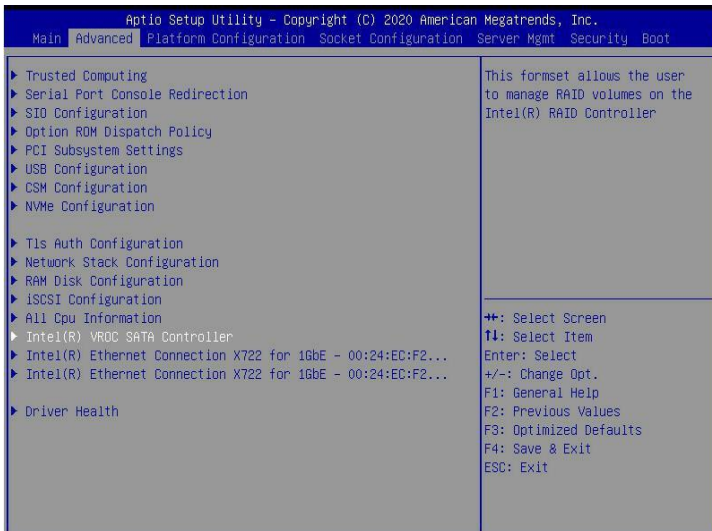

Figure 6-3

➤ Create RAID

a) Select Create RAID Volume and press enter. Figure 6-4

❖ Figure 6-4 Create RAID

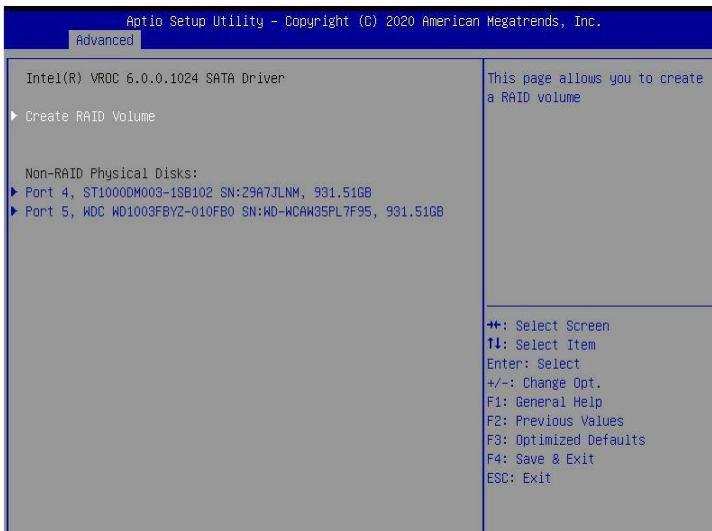

Figure 6-4

a) Change the name of the created raid, and note that it cannot contain special characters. Figure 6-5

❖ Figure 6-5 Create RAID name

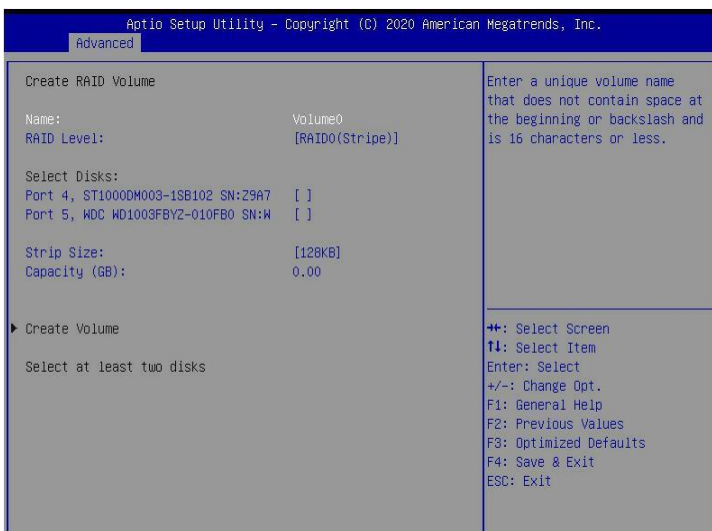

Figure 6-5

a) RAID Level: You can select the level of group raid, as shown in Figure 6-6

✧ Figure 6-6 Select the level of group RAID

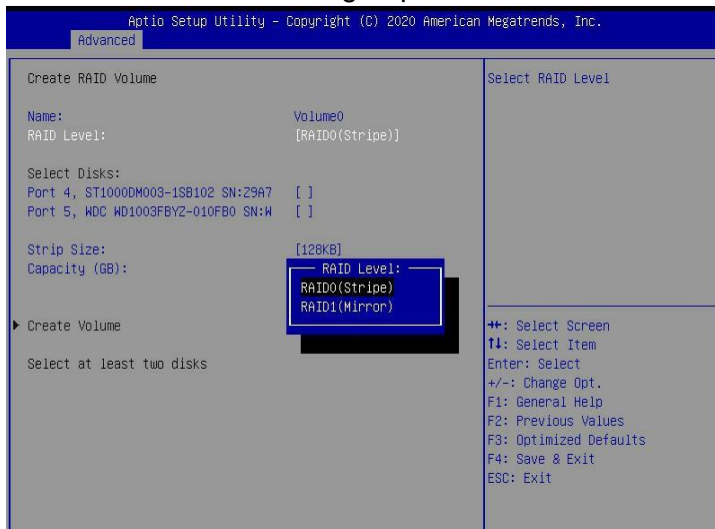

Figure 6-6

b) Select Disks: Press the space bar to select the disks that need to participate in the RAID group. Figure 6-7

✧ Figure 6-7 Selecting the disks of group RAID

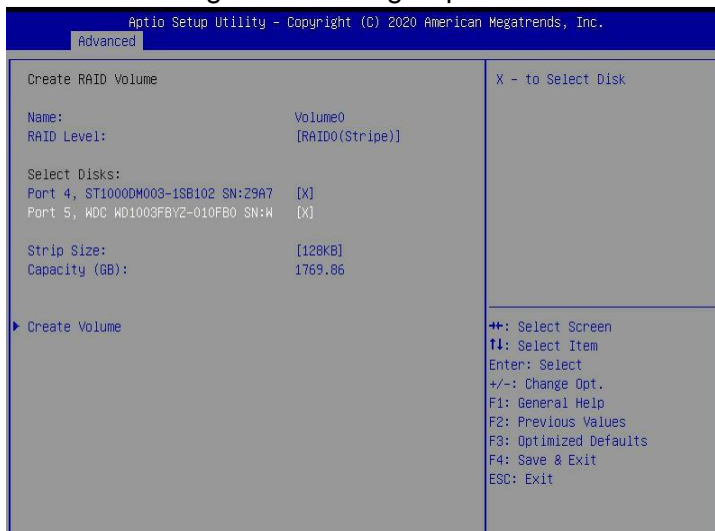

Figure 6-7

c) Select Create Volume and press Enter to group the raid.

✧ Related parameters are described in Table 1- 28:

Parameter	Description
Name	The name of the RAID.
RAID Level	RAID level, which determines the performance, fault tolerance and capacity of the logical disk.
Select Disks	Select the member disks that make up the RAID. Available disks are displayed under the Select Disks column, press Enter Select the disk, [X] means that the disk has been selected.
Strip Size	Stripe size, the size of striped data blocks written on each disk.
Capacity	The capacity of the logical disk.

Table 1- 23

After the RAID is created, it will be displayed under the RAID Volumes directory. Select a RAID and press Enter to view the detailed information of the RAID (including RAID name, level, and disk information, etc.).

➤ **Configure hot spare disk**

a) As shown in Figure 6-8, select the disk to be configured as a hot spare disk and press Enter.

✧ Figure 6-8 Select the disk to be configured as a hot spare disk

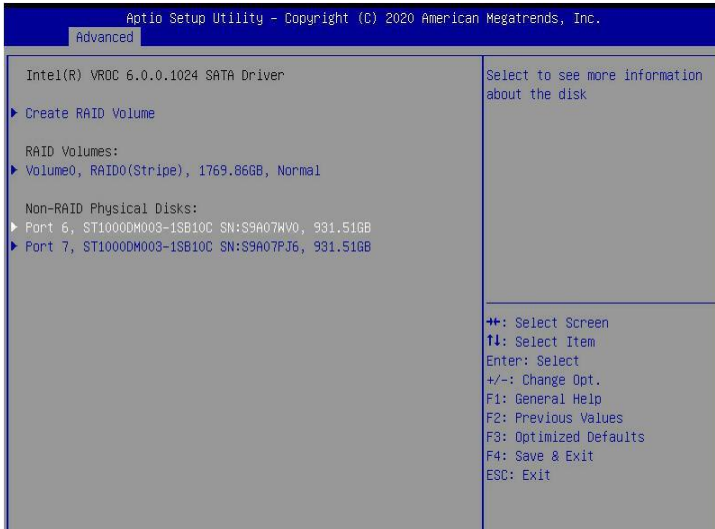

Figure 6-8

b) Enter the interface shown in Figure 6-9, select "Mark as Spare", and press Enter.

✧ Figure 6-9 Hot spare disk configuration interface

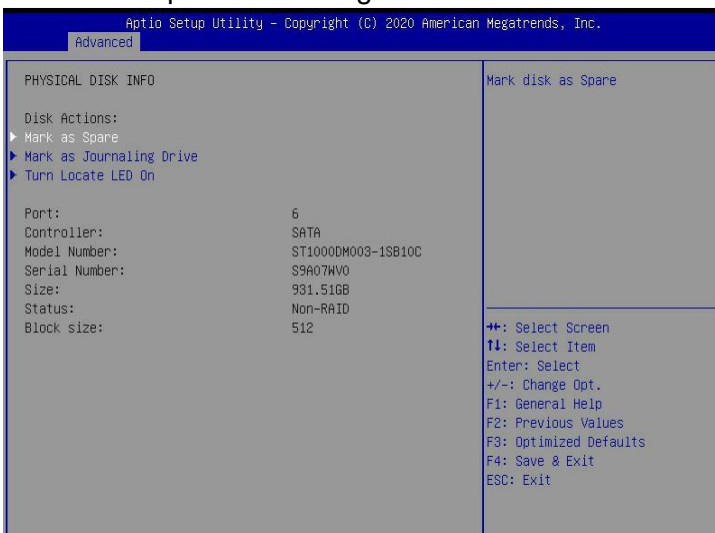

Figure 6-9

c) Enter the interface shown in Figure 6-10, select "Yes", and press Enter to complete the hot spare disk configuration.

✧ Figure 6-10 Confirm hot spare disk configuration

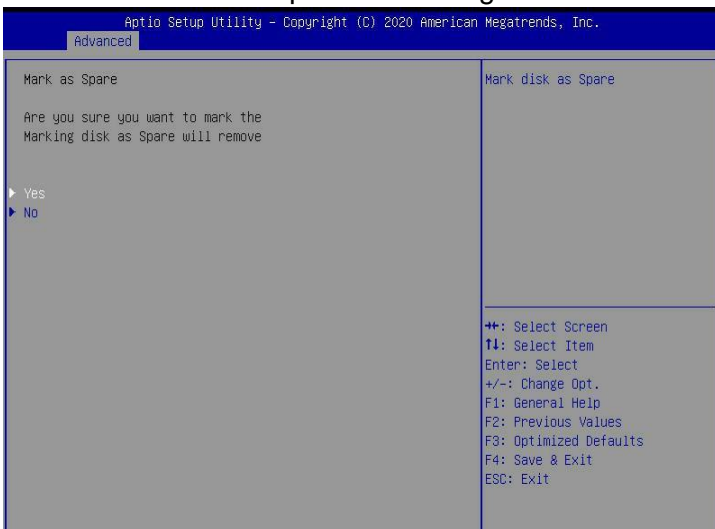

Figure 6-10

➤ Delete RAID

- a) Enter the RSTe configuration interface.
- b) As shown in Figure 6-11, select the RAID to be deleted in the RAID Volumes directory and press Enter.

❖ Figure 6-11 Select the RAID to be deleted

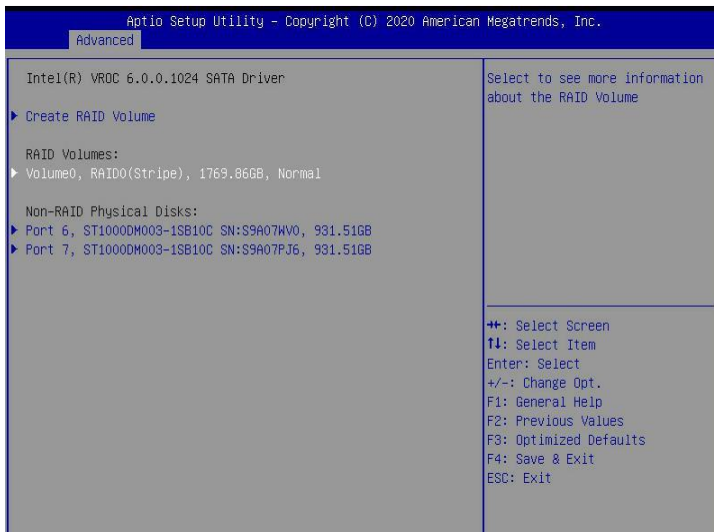

Figure 6-11

- c) Enter the RAID information interface shown in Figure 6-12, select Delete, and press Enter to delete the RAID.

❖ Figure 6-12 RAID Information Interface

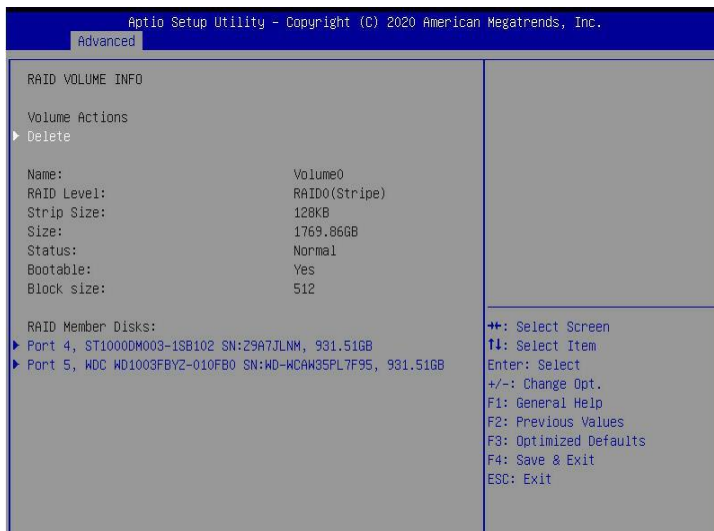

Figure 6-12

6.1.2 Configure RAID in Legacy Boot Mode

➤ Set RSTe working mode

- Enter the BIOS Setup interface.
 - Move to PlatForm page-->PCH Configuration-->PCH Sata Configuration
- ❖ Figure 6-13 PCH SATA Configuration interface

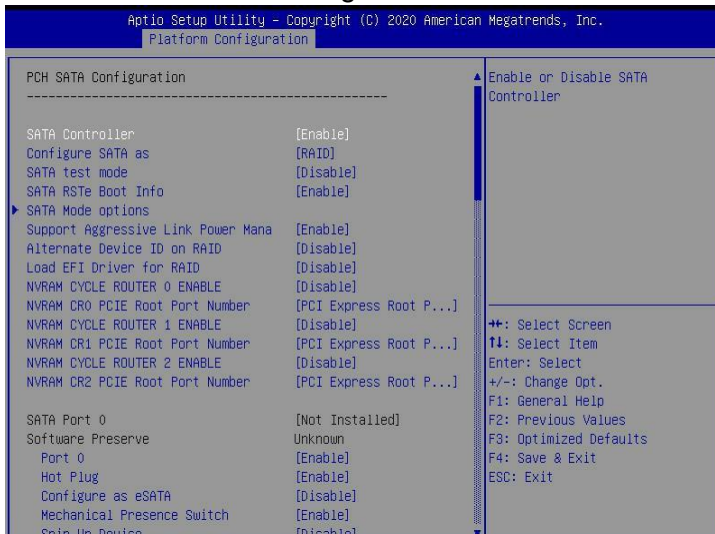



Figure 6-13

 **Instruction** RSTe onboard software RAID has two controllers, SATA and sSATA, which manage the disks connected to the two interfaces of the RAID card. The SATA controller supports up to 8 disks, and the sSATA controller supports up to 6 disks.

- Enter the interface shown in Figure 6-14, select Configure SATA As, and press Enter to select the operating mode of RSTe onboard software RAID.

❖ Figure 6-14 Modify the working mode of the RAID card

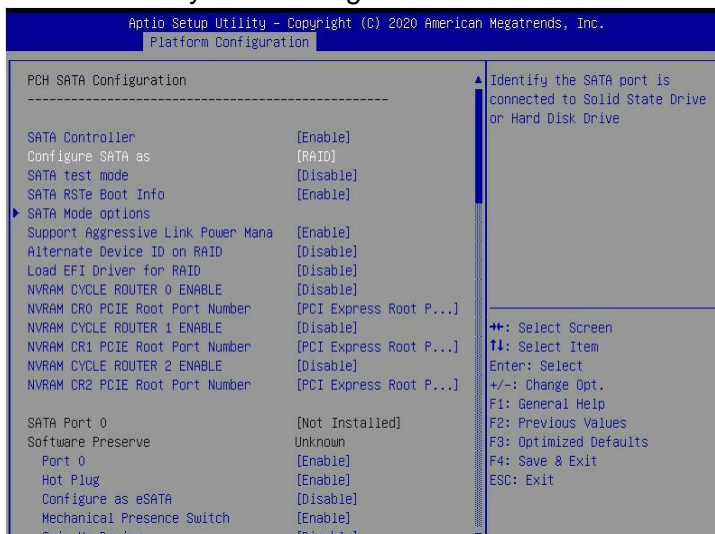

Figure 6-14

➤ **Enter RSTe configuration interface**

a) Power on or restart the server. After the interface shown in Figure 6-15 appears during BIOS startup, press Ctrl+I.

✧ Figure 6-15 BIOS startup interface



Figure 6-15

 **Instruction** If the working mode of both sSATA and SATA controllers is set to RAID, the prompt "Press <CTRL>I to enter Configuration Utility" will appear twice during the BIOS startup process, corresponding to sSATA and SATA controllers in turn. Please configure RAID according to the configuration. Select the controller for the desired disk.

b) Enter the RSTe configuration interface shown in Figure 6-16 (see Table 1-29 for interface description). Please refer to the key operation prompts on the lower border of the interface to navigate and modify settings in the interface.

✧ Figure 6-16 RSTe configuration interface



Figure 6-16

✧ Table 1-29 RSTe configuration interface description

Located on the upper side of the interface, you can perform the following operation tasks:

Option	Description
MAIN MENU (main menu)	<ol style="list-style-type: none"> 1. Create RAID Volume: Configure RAID volume. 2. Delete RAID Volume: Delete RAID volume. 3. 3. Reset Disks to Non-RAID: Clear the RAID configuration information of the disk. 4. Mark Disks as Spare: Configure hot spare disks. 5. Exit: Exit.
DISK/VOLUME INFORMATION (Disk and volume information)	Located at the bottom of the configuration interface, you can view the summary information of the created RAID and physical disks.

Table 1- 24

➤ **Common tasks to configure RAID:**

- a) Enter the RSTe configuration interface.
 - b) As shown in Figure 6-17, select Create RAID Volume on the RSTe configuration interface and press Enter.
- ◇ Figure 6-17 RSTe configuration interface



Figure 6-17

c) Enter the interface shown in Figure 6-18, and make the corresponding settings in the Name, RAID Level, Disks, Strip Size and Capacity columns (for parameter descriptions, see Table 1-30), then select Create Volume and press Enter.

✧ Figure 6-18 Create RAID Volume interface



Figure 6-18

✧ Table 1-30
Parameter

Parameter	Description
Name	The name of the RAID.
RAID Level	RAID level. The RAID level determines the performance, fault tolerance, and capacity of the logical disk.
Disks	Select the member disks that make up the RAID. Select the Disks column and press Enter, and press SPACE to select the disk.
Strip Size	Stripe size, the size of striped data blocks written on each disk.
Capacity	The capacity of the logical disk.

descriptio

Table 1- 25

d) Enter the interface shown in Figure 6-19, you can view the detailed information of the RAID (including RAID name, level, and disk information, etc.).

✧ Figure 6-19 RAID information interface



Figure 6-19

Configure hot spare disk:

- a) Enter the RSTe configuration interface.
 - b) As shown in Figure 6-20, select Mark Disks as Spare on the RSTe configuration interface, and press Enter.
- ✧ Figure 6-20 RSTe configuration interface



Figure 6-20

- c) Enter the interface shown in Figure 6-21, select the disk to be configured as a hot spare disk and press SPACE to select it, then press Enter, in the prompt bar that appears, enter y and press Enter to complete the hot spare disk configuration.

✧ Figure 6-21 Select Disk

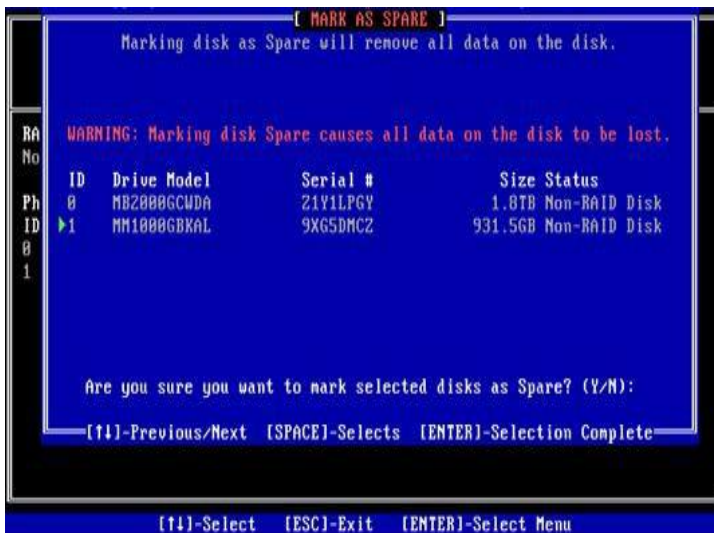

Figure 6-21

- d) In the RSTe configuration interface, you can see the hot spare disk information, as shown in Figure 6-22.

✧ Figure 6-22 View hot spare disk information on the RSTe configuration interface

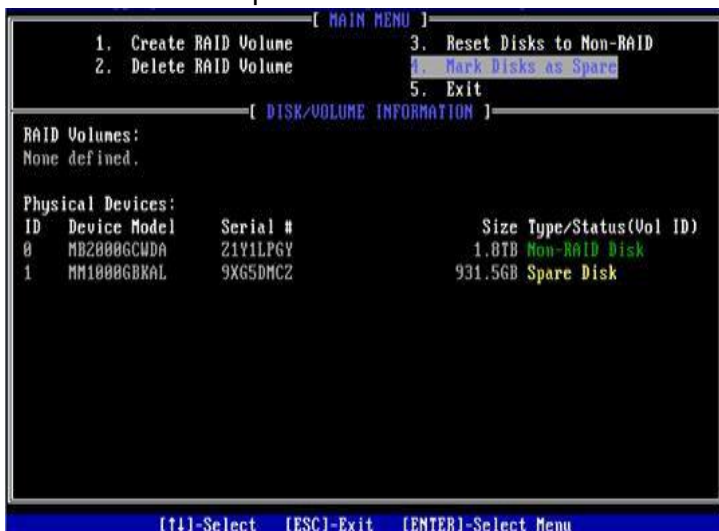

Figure 6-22

Delete RAID:

- Enter the RSTe configuration interface.
 - As shown in Figure 6-23, select Delete RAID Volume on the RSTe configuration interface and press Enter.
- ✧ Figure 6-23 RSTe configuration interface

```
[ MAIN MENU ]
1. Create RAID Volume      3. Reset Disks to Non-RAID
2. Delete RAID Volume     4. Mark Disks as Spare
                          5. Exit
-----
[ DISK/VOLUME INFORMATION ]
RAID Volumes:
ID  Name      Level      Strip  Size Status  Bootable
0   LD_RAID1  RAID1(Mirror)  N/A   10.0GB Normal Yes

Physical Devices:
ID  Device Model  Serial #      Size Type/Status(Vol ID)
0   MB2000GCUDA  21X1RRM4     1.0TB Member Disk(0)
1   MM1000GBKAL  9XG6RFQ7     931.5GB Member Disk(0)

[↑↓]Select  [ESC]-Exit  [ENTER]-Select Menu
```

Figure 6-23

- Enter the interface shown in Figure 6-24, select the RAID to be deleted, and press Delete to complete the deletion.
- ✧ Figure 6-24 Select the RAID to be deleted

```
[ DELETE VOLUME MENU ]
Name      Level      Drives  Capacity  Status  Bootable
LD_RAID1  RAID1(Mirror)  2       10.0GB   Normal  Yes

[ HELP ]

Deleting a volume will reset the disks to non-RAID.
WARNING: ALL DISK DATA WILL BE DELETED.

[↑↓]Select  [ESC]-Previous Menu  [DEL]-Delete Volume
```

Figure 6- 24

6.2 LSI 9361-8i group RAID

6.2.1 Configure RAID in UEFI boot mode

➤ Enter the RAID card configuration interface

- During the server startup, press Delete/Esc as prompted to enter the BIOS Setup interface.
 - Select Advanced>AVAGO MegaRAID<AVAGO MegaRAID SAS 91311-8i>Configuration Utility, and press Enter.
 - Enter the interface shown in Figure 6-25, and five types of configuration tasks are displayed on the interface (refer to Table 1-31 for related instructions).
- ✧ Figure 6-25 RAID card configuration interface, as shown in Figure 6-25

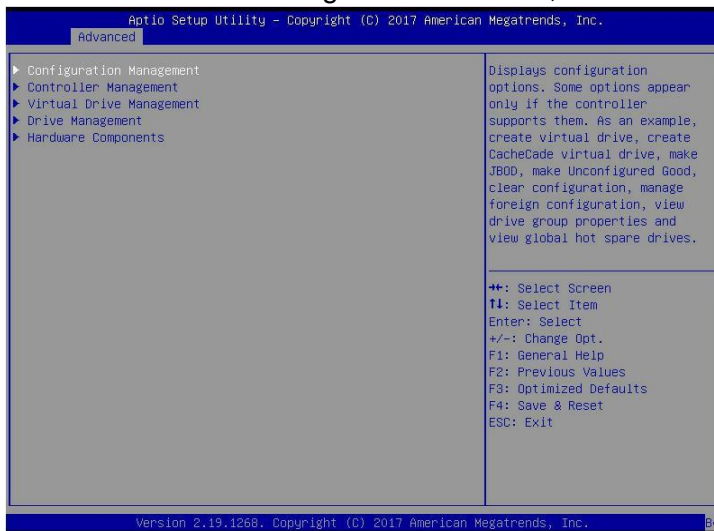

Figure 6-25

✧ Table 1-31 Parameter description

Options	Summary description
Configuration Management	Select configuration management to perform tasks, such as creating logical disks, viewing disk group properties, and viewing Hot backup information and clear configuration.
Controller Management	Select Controller Management to view and manage controller properties and perform tasks, such as clearing the controller Event, dispatch and run controller events, and run patrol reading.
Virtual Drive Management	Select logical disk management to perform tasks, such as viewing logical disk attributes, locating logical disks, And run a consistency check.
Drive Management	Select Disk Management to view physical disk properties and perform tasks, such as locating disks, initializing Disk and rebuild after disk failure.
Hardware Components	Select hardware components to view super capacitor properties, manage super capacitors and manage peripheral components.

➤ **Common task switching disk mode:**

The RAID card supports switching between the following three disk modes.

1. Unconfigured Good: indicates that the physical disk is normal and can be used to configure RAID or hot spare disks.
2. Unconfigured Bad: It means that there is residual RAID information on the physical disk, which needs to be cleared manually.
3. JBOD: Just a Bunch Of Disks, only connect the disks in series to expand the capacity, but does not have the RAID function.

Here is an example of switching from Unconfigured Good mode to Unconfigured Bad mode.

- a) As shown in Figure 6-26, select Drive Management on the RAID card configuration interface and press Enter.

✧ Figure 6-26 RAID card configuration interface

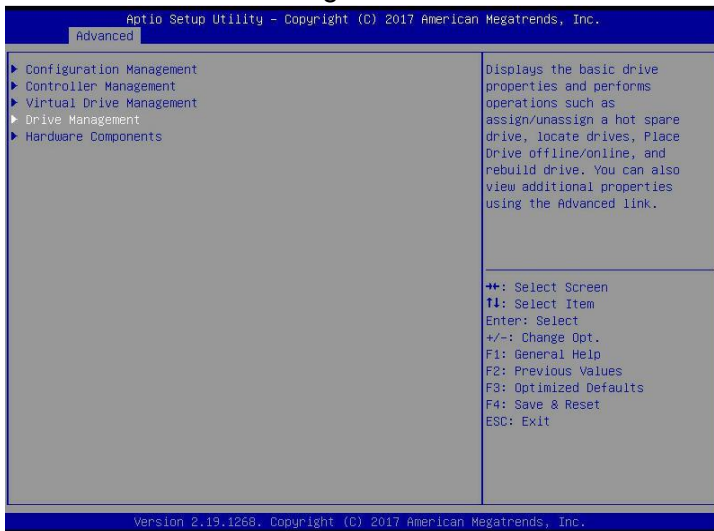

Figure 6-26

- b) Enter the interface shown in Figure 6-27, select the disk to be configured, and press Enter.

✧ Figure 6-27 Drive Management management interface

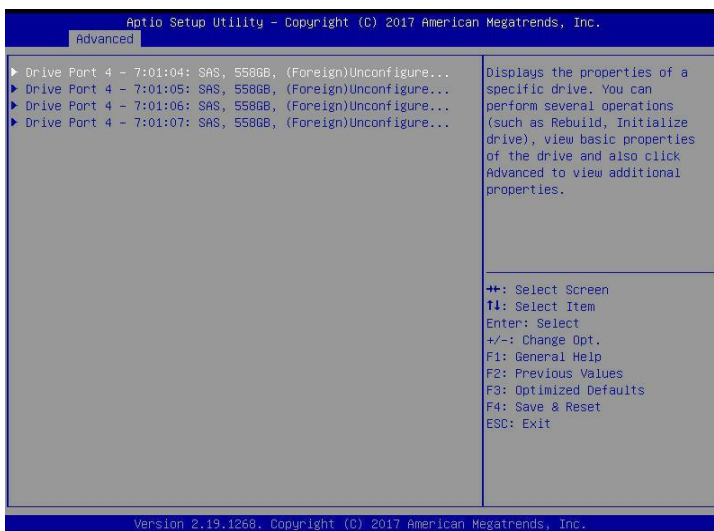

Figure 6-27

- c) Enter the interface shown in Figure 6-28, select Operation, press Enter, and then select Make Unconfigured Bad in the pop-up dialog box, and press Enter.

✧ Figure 6-28 Operation interface

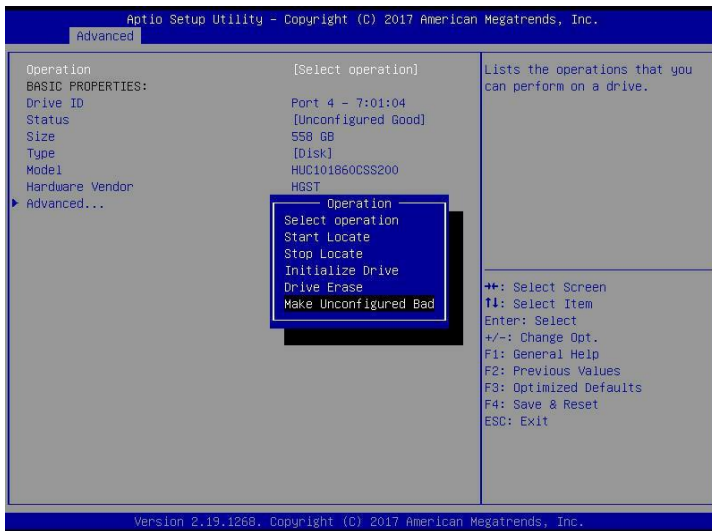

Figure 6-28

d) Enter the interface shown in Figure 6-29, select Go, and press Enter.

✧ As shown in Figure 6-29, select Go

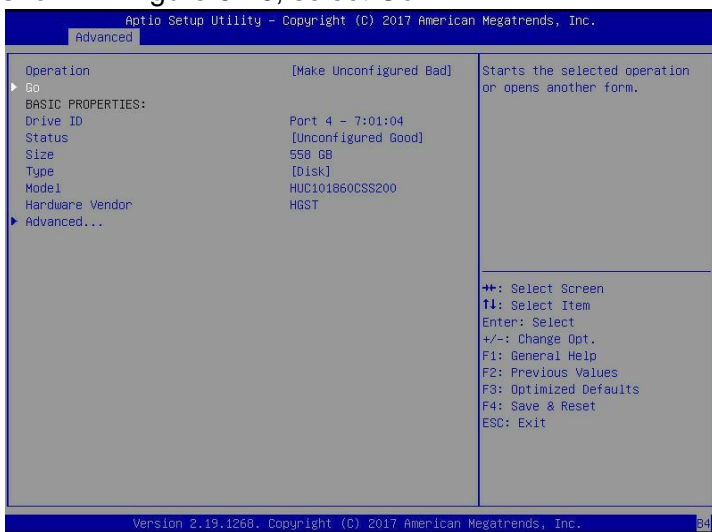

Figure 6- 29

e) Enter the interface shown in Figure 6-30 to complete the operation of switching the disk mode.

✧ Figure 6-30 Finish switching disk mode

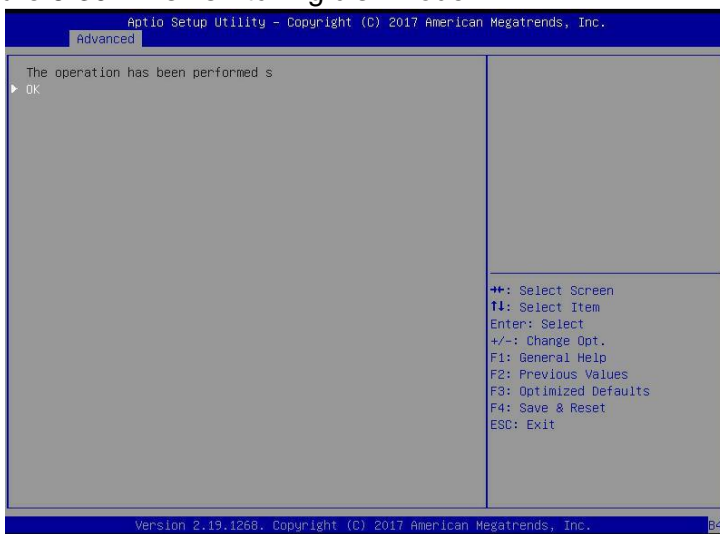

Figure 6-30

Create RAID:

- a) As shown in Figure 6-31, select Configuration Management on the RAID card configuration interface, and press Enter.

❖ Figure 6-31 RAID card configuration interface

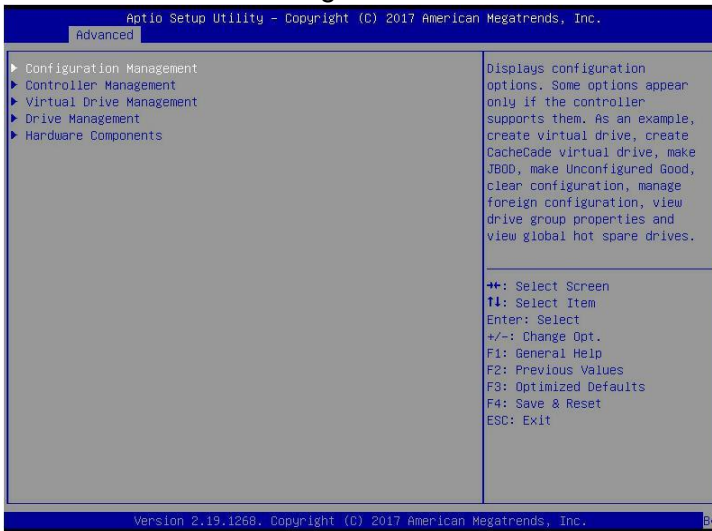

Figure 6-31

- b) Enter the interface shown in Figure 6-32, select Create Virtual Drive, and press Enter.

❖ Figure 6-32 Select Create Virtual Drive

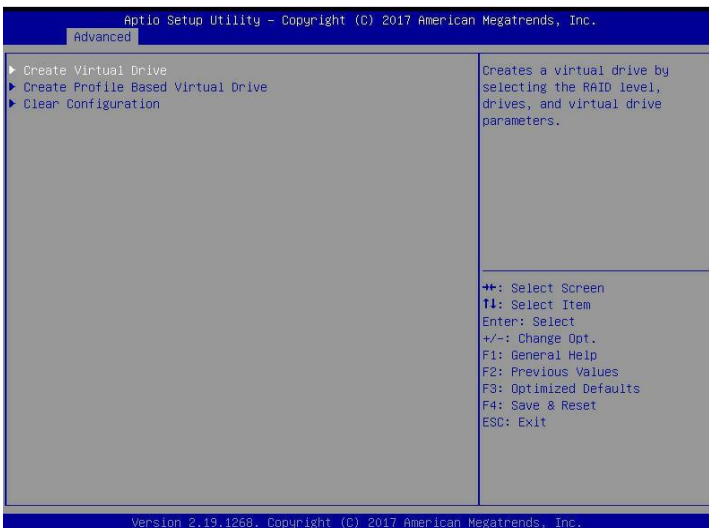

Figure 6-32

- c) Enter the interface shown in Figure 6-33, select Select RAID Level, set the RAID level, and press Enter.

❖ Figure 6-33 Set RAID level

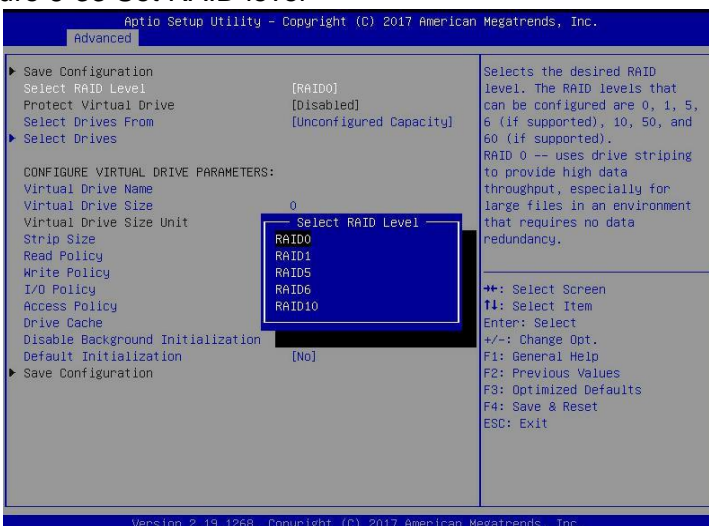

Figure 6- 33

- d) Enter the interface shown in Figure 6-34, select Select Drives From, set the disk capacity source of the RAID, and press Enter.
- ✧ [Unconfigured Capacity] indicates that the capacity comes from the remaining capacity of the disk that has been configured with RAID.
- ✧ [Free Capacity] means that the capacity comes from an empty disk.
- ✧ Figure 6-34 Set the disk capacity source of RAID

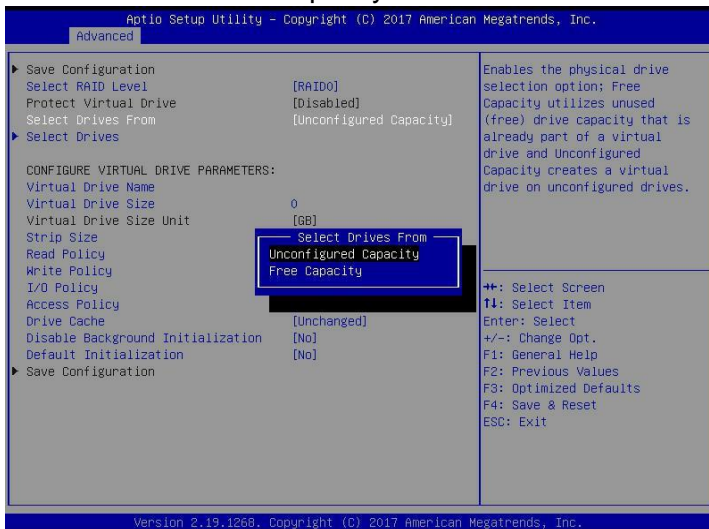

Figure 6- 34

- e) Enter the interface shown in Figure 6-35, select Select Drives, and press Enter.
- ✧ Figure 6-35 Select Select Drives

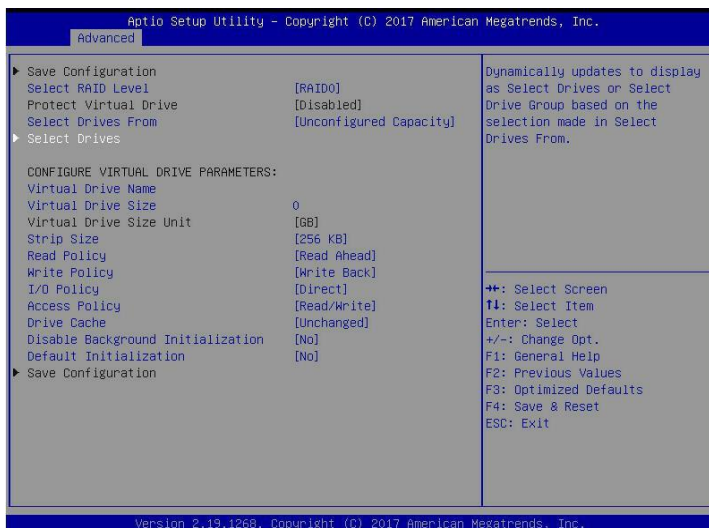

Figure 6-35

- f) Enter the interface shown in Figure 6-36, select the disk to be used to configure RAID, [Enabled] means selected, then select Apply Changes, and press Enter. If the status of the disk is JBOD or Unconfigured Bad, it cannot be selected.

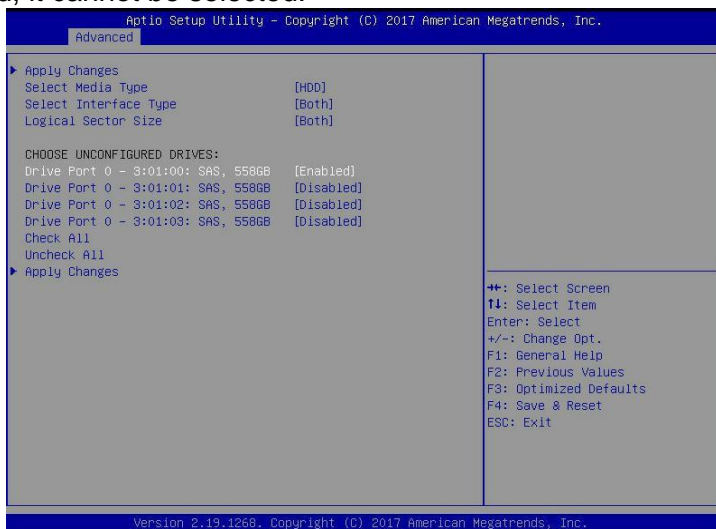

Figure 6- 36

- g) Enter the interface shown in Figure 6-37, make corresponding settings (for parameter descriptions, see Table 1-32), then select Save Configuration, and press Enter.

❖ Figure 6-37 Set RAID parameters

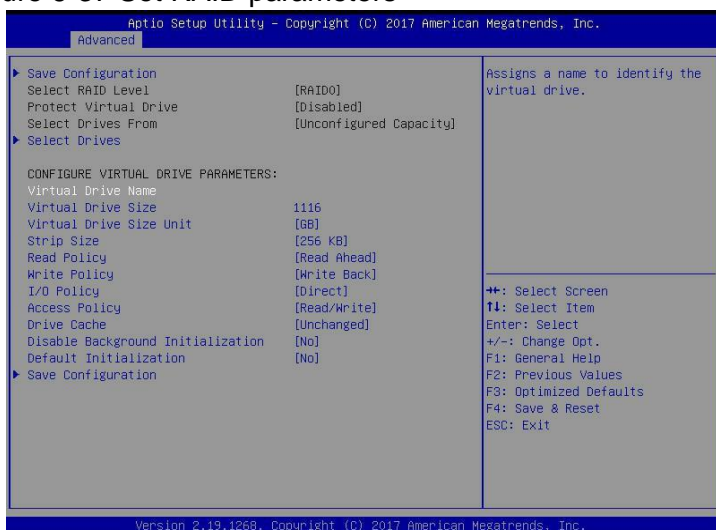



Figure 6- 37

❖ Parameter Description

Parameter	Description
Virtual Drive Name	RAID name, only supports letters, numbers and underscores, not case sensitive
Virtual Drive Size	RAID capacity
Virtual Drive Size Unit	RAID capacity unit
Stripe Size	Stripe size, the size of the striped data block written on each disk
Read Policy	The read cache strategy is divided into Read Ahead (open read cache) and No Read Ahead (close read cache) Save)
Write Policy	Write caching strategy, divided into Write Through (write through mode), Always Write Back (write back Mode 1) and Write Back (write back mode 2)
I/O Policy	I/O strategy, divided into Cached (cache mode) and Direct (direct read and write mode)
Access Policy	Read and write strategy, divided into Read/Write (read/write), Read Only (read only) and Blocked (prohibited operation)

Drive Cache	Disk caching strategy, divided into Enable (open), Disable (close) and Unchanged (automatic)
Default Initialization	Default initialization method
Save Configuration	Save the configuration created by the wizard

Table 1- 27

 Instruction

- ✧ Do not use special characters as the name of the RAID.
- ✧ Compared with No Read Ahead, Write Through and Direct, Read Ahead, Write Back and Cached have improved performance, but data consistency cannot be guaranteed.
- ✧ If the super capacitor is abnormal, when the write cache strategy selects "Write Back", the firmware write data implementation is "Write Through"; the write cache strategy selects "Always Write Back", the firmware write data implementation is "Write Back".

h) Enter the interface shown in Figure 6-38, select Confirm to enable it, select Yes, and press Enter.

✧ Figure 6-38 Confirm configuration

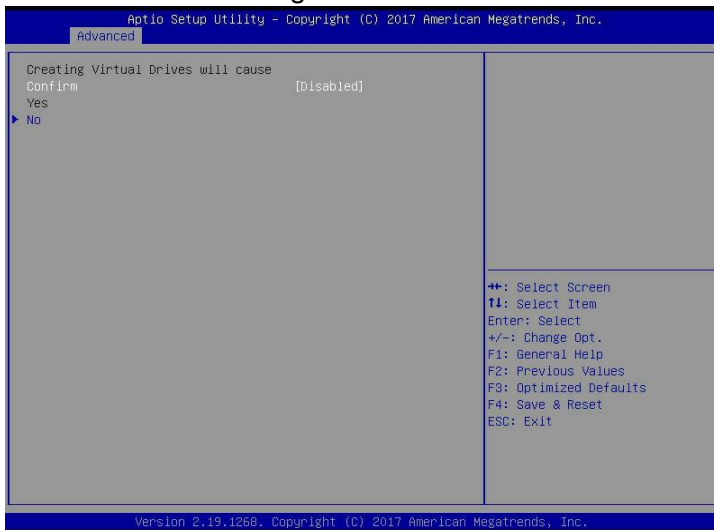

Figure 6- 38

i) Enter the interface shown in Figure 6-39, complete the RAID configuration operation, select OK to return to the RAID card configuration interface.

✧ Figure 6-39 Complete RAID configuration

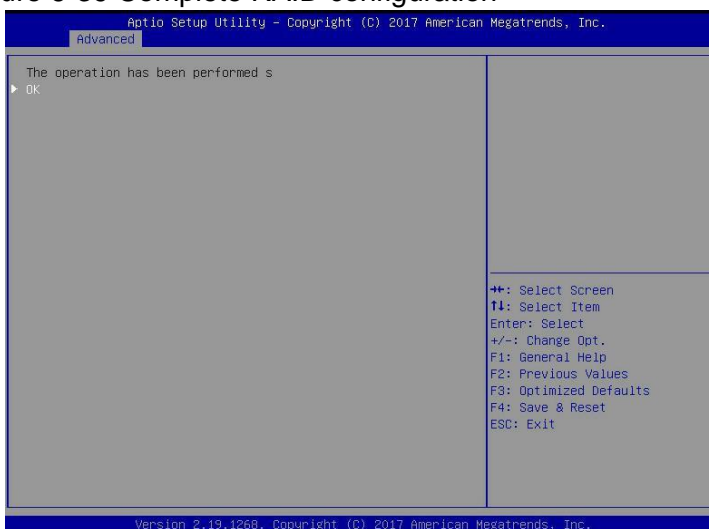

Figure 6-39

j) As shown in Figure 6-40, select Virtual Drive Management on the RAID card configuration interface, and press Enter.

❖ Figure 6-40 RAID card configuration interface



Figure 6- 40

k) Enter the interface shown in Figure 6-41, you can see the created RAID, select the RAID you want to view, and press Enter.

❖ Figure 6-41 Vitrual Drive Management interface

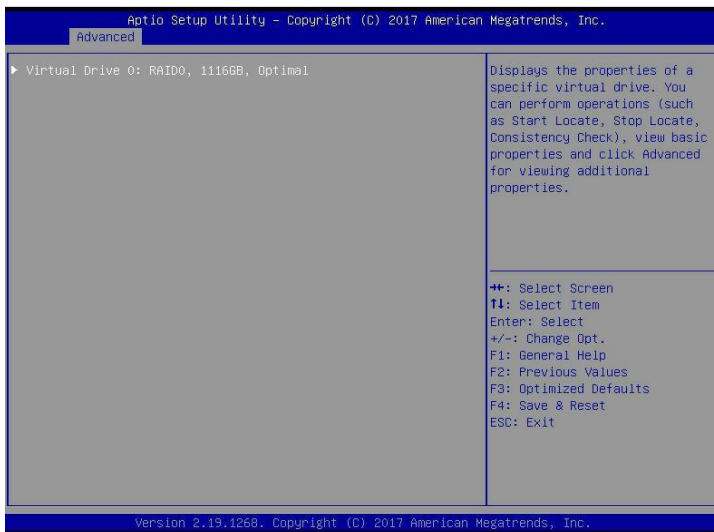

Figure 6- 41

- l) Enter the interface shown in Figure 6-42, select View Associated Drives, and press Enter to view the detailed information of the RAID (including RAID name, level, and disk information, etc.).

✧ Figure 6-42 Select View Associated Drives

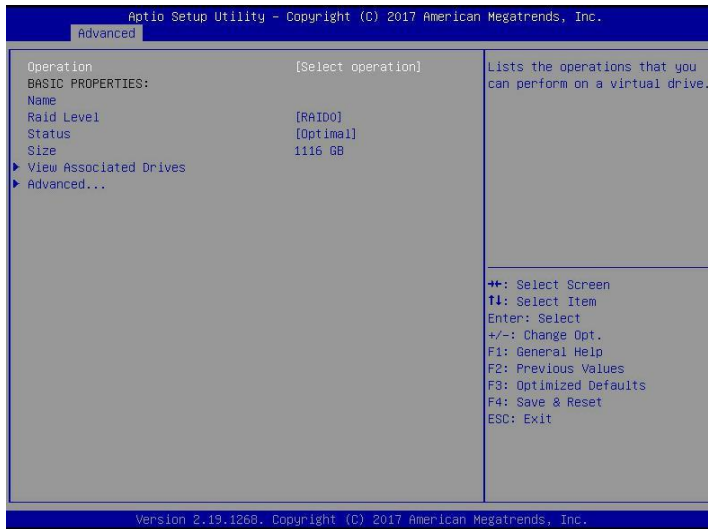
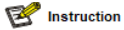

Figure 6- 42

Configure hot spare disk:

After RAID is configured, hot spare disks are generally configured to improve data security. You can configure a global hot spare disk or a dedicated hot spare disk as needed.



- ✧ Hot spare disks are only available for RAID levels with redundancy.
 - ✧ The capacity of the hot spare disk is larger than the capacity of a single member disk of the RAID to contribute to the RAID.
 - ✧ Only the disk whose configuration mode is Unconfigured Good is supported as a hot spare disk.
 - ✧ Configure global hot spare disk
- a) As shown in Figure 6-43, select Drive Management on the RAID card configuration interface and press Enter.

✧ Figure 6-43 RAID card configuration interface

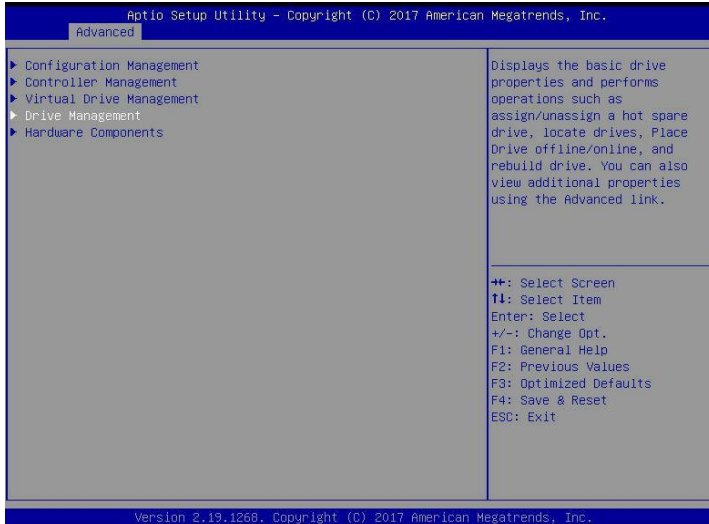

Figure 6- 43

- b) Enter the interface shown in Figure 6-44, select the disk to be configured as a global hot spare disk, and press Enter.

✧ Figure 6-44 Drive Management management interface

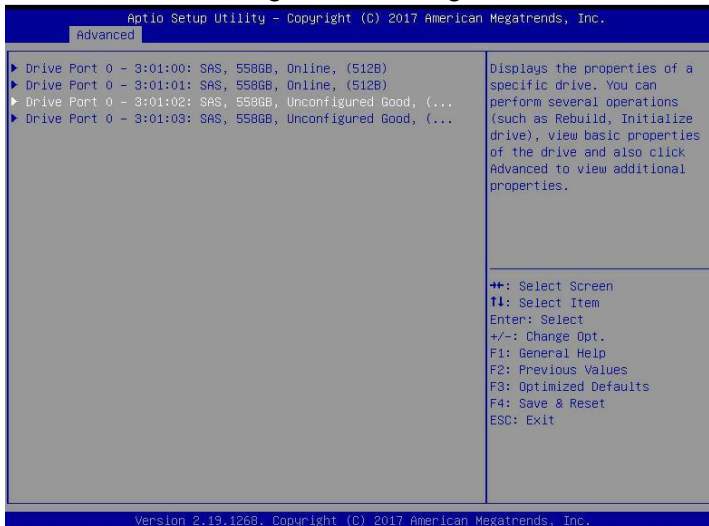

Figure 6-44

- c) Enter the interface shown in Figure 6-45, select Operation, press Enter, then select Assign Dedicated Hot Spare Drive, and press Enter.

✧ Figure 6-45 Operation interface

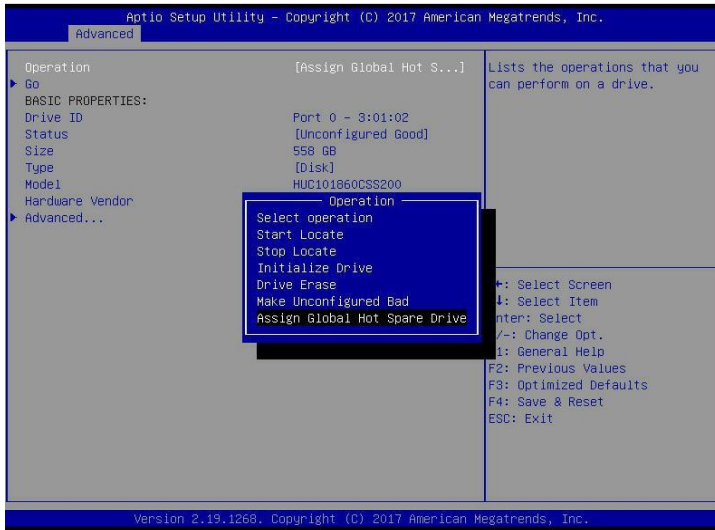

Figure 6-45

d) Enter the interface shown in Figure 6-46, select Go, and press Enter.

✧ Figure 6-46 Select Go

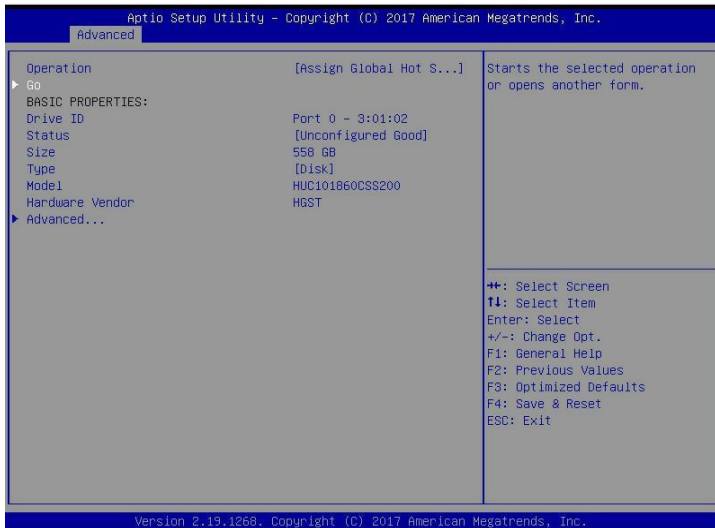

Figure 6- 46

e) Enter the interface shown in Figure 6-47, select Confirm to enable it, select Yes, and press Enter.

✧ Figure 6-47 Confirm configuration

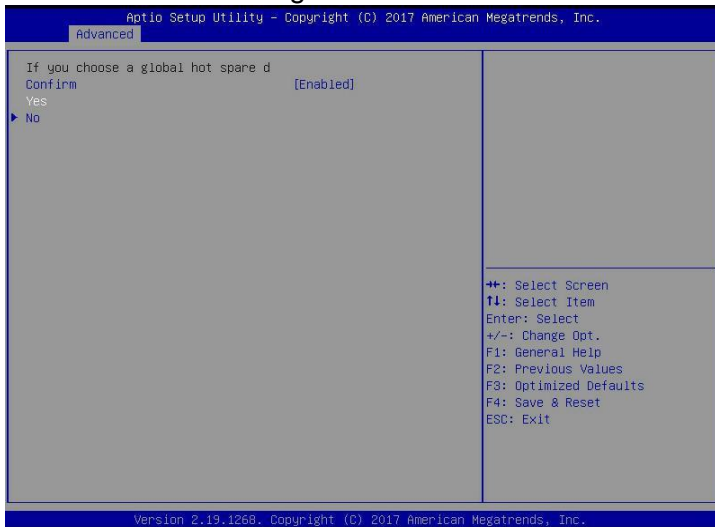

Figure 6- 47

f) Enter the interface shown in Figure 6-48 to complete the configuration of the global hot spare disk.

✧ Figure 6-48 Complete configuration of global hot spare disk

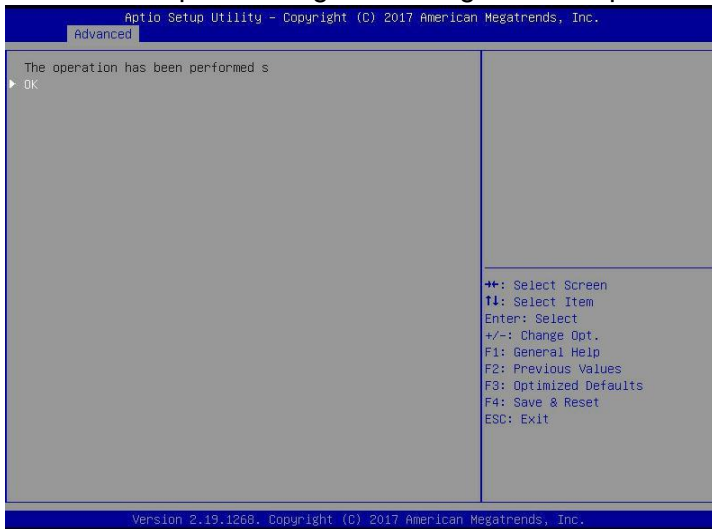

Figure 6-48

Delete RAID:

- a) As shown in Figure 6-49, select Virtual Drive Management on the RAID card configuration interface, and press Enter.

❖ Figure 6-49 RAID card configuration interface

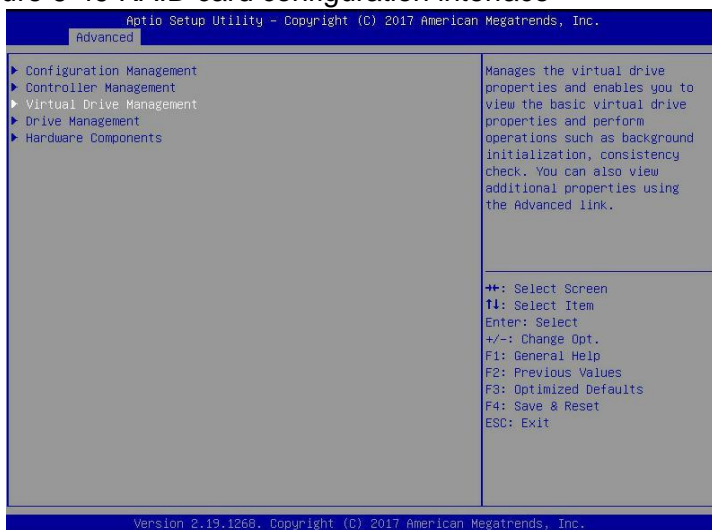

Figure 6-44

- b) Enter the interface shown in Figure 6-50, select the logical disk to be deleted, and press Enter.

❖ Figure 6-50 Logical Disk Management Interface



Figure 6- 50

c) Enter the interface shown in Figure 6-51, select Operation, press Enter, and then select Delete Virtual Drive in the pop-up dialog box, and press Enter.

❖ Figure 6-51 Operation operation interface

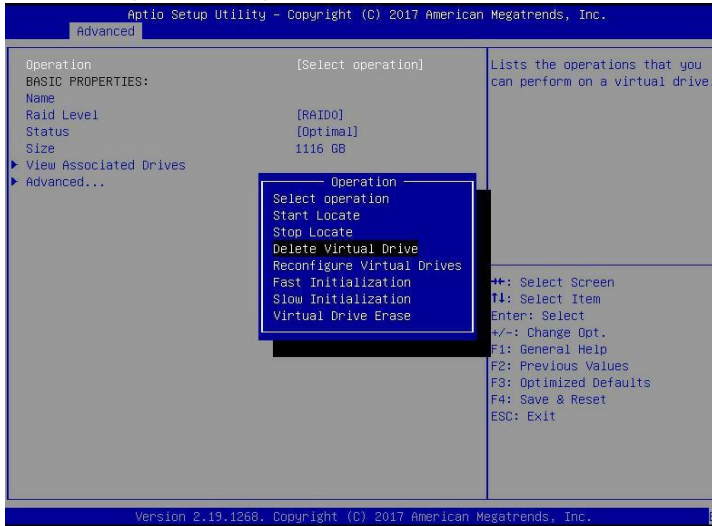

Figure 6-51

d) Enter the interface shown in Figure 6-52, select Go, and press Enter.

❖ Figure 6-52 Select Go

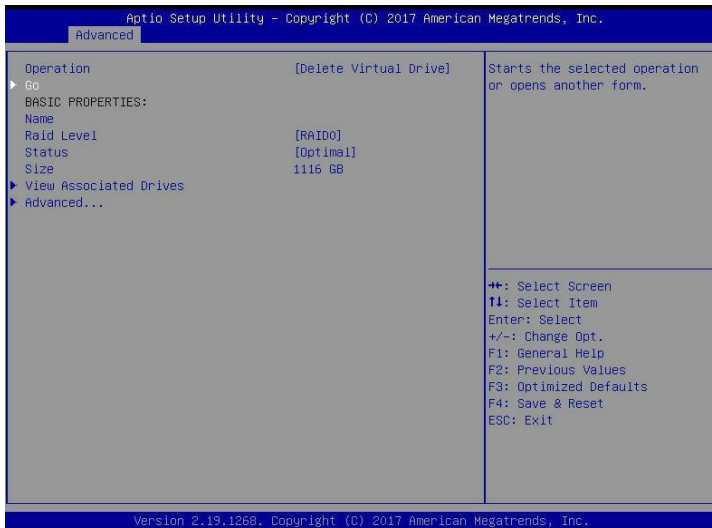

Figure 6-52

e) Enter the interface shown in Figure 6-53, select Confirm to enable it, select Yes, and press Enter.

✧ Figure 6-53 Confirm deletion



Figure 6-53

f) Enter the interface shown in Figure 6-54 to complete the RAID deletion operation.

✧ Figure 6-54 Completed RAID deletion

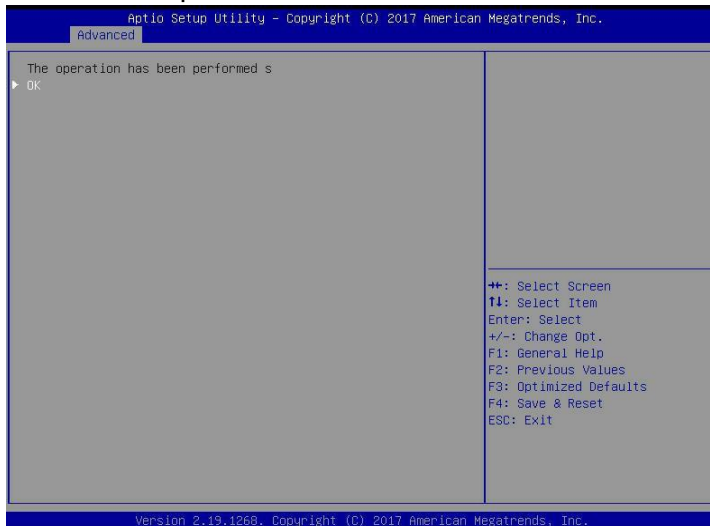

Figure 6-54

Locate the disk location:

1. Locate the physical disk

a) As shown in Figure 6-55, select Drive Management on the RAID card configuration interface and press Enter.

❖ Figure 6-55 Select Drive Management

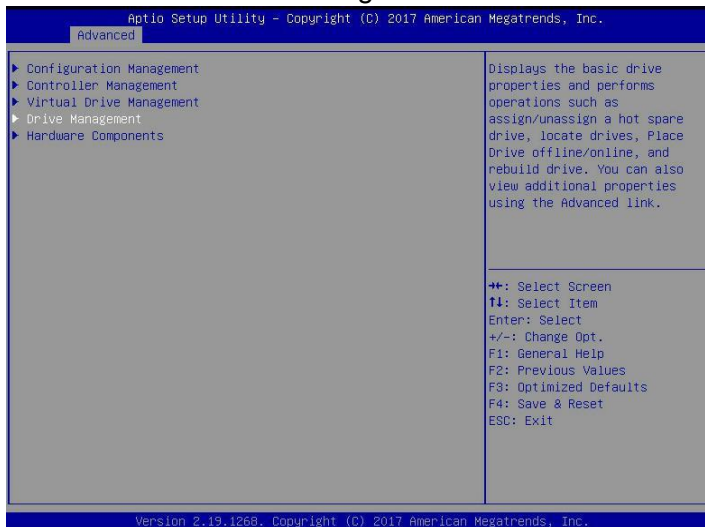

Figure 6-55

b) Enter the interface of Figure 6-56, select the disk to be located, and press Enter.

❖ Figure 6-56 Select the disk to be located

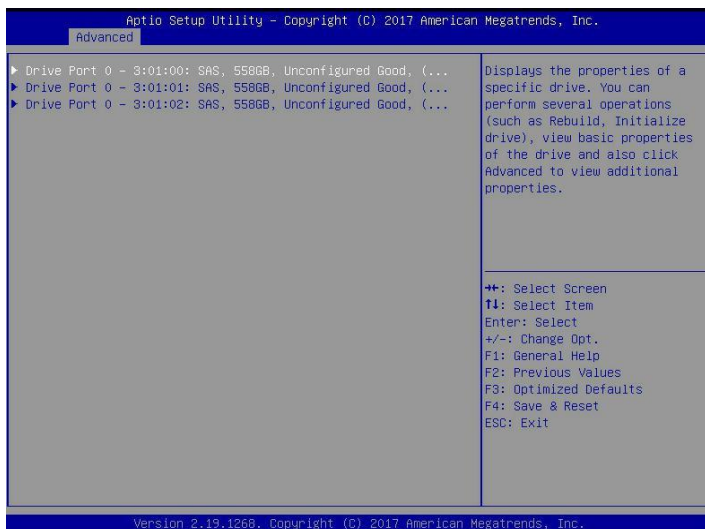

Figure 6-56

c) Enter the interface of Figure 6-57, select Operation, press Enter, and then select Start Locate in the pop-up dialog box, and press Enter.

❖ Figure 6-57 Operation interface

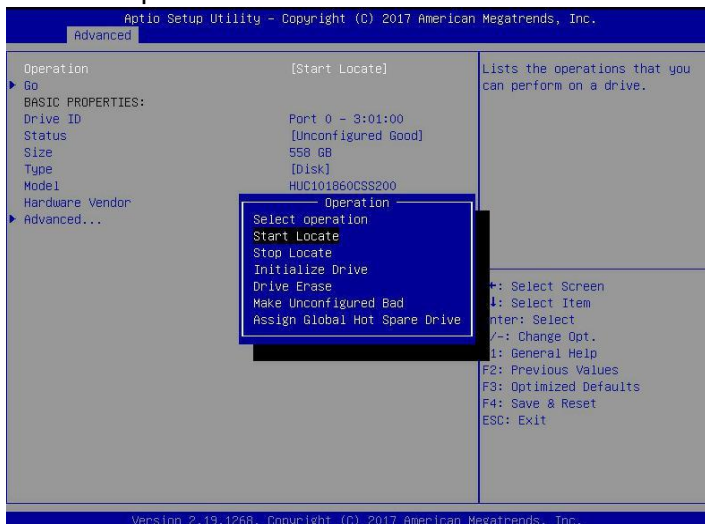

Figure 6-57

d) Enter the interface of Figure 6-58, select Go, and press Enter.

❖ Figure 6-58 Select Go



Figure 6-58

e) Enter the interface of Figure 6-59 to complete the operation of locating the physical disk position.

❖ Figure 6-59 Finish positioning the physical disk location



Figure 6-59

2. Locate all disks in the logical disk

a) As shown in Figure 6-60, select Virtual Drive Management on the RAID card configuration interface, and press Enter.

❖ Figure 6-60 RAID card configuration interface



Figure 6- 60

b) Enter the interface of Figure 6-61, select the logical disk to be located, and press Enter.

❖ Figure 6-61 Select the logical disk to be located

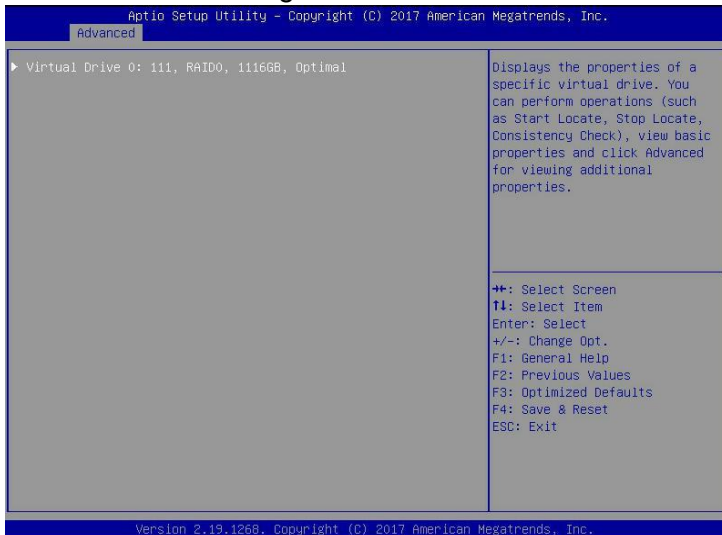

Figure 6-61

c) Enter the interface of Figure 6-62, select Operation, press Enter, and then select Start Locate in the pop-up dialog box, and press Enter.

❖ Figure 6-62 Operation interface

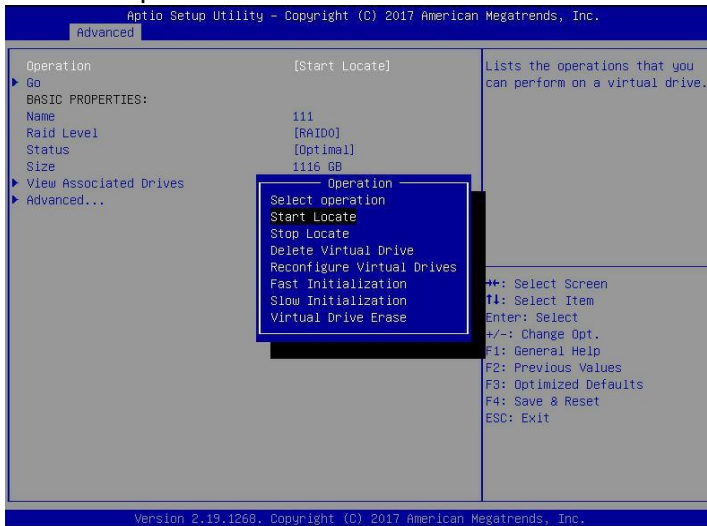

Figure 6-61

d) Enter the interface of Figure 6-63, select Go, and press Enter.

❖ Figure 6-63 Select Go

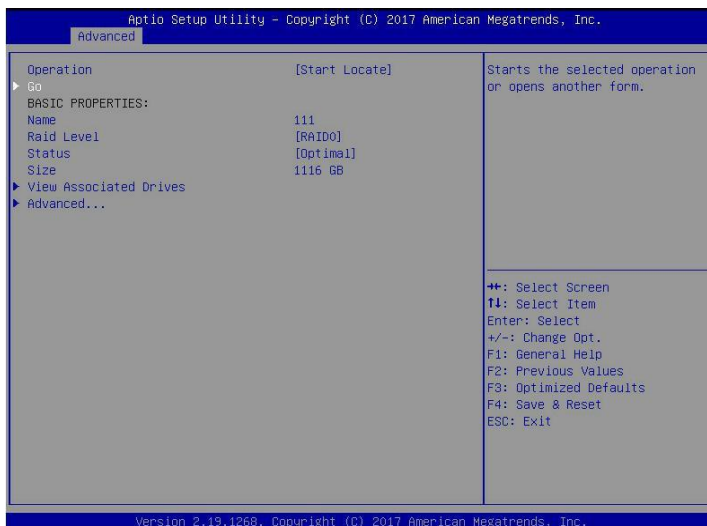

Figure 6-63

e) Enter the interface of Figure 6-64 to complete the operation of locating all disk positions in the logical disk.

✧ Figure 6-64 Finish locating all disks in the logical disk



Figure 6-64

Initialize the logical disk:

This function is used to initialize the internal data space of the logical disk so that it can be recognized and used by the operating system.

- a) As shown in Figure 6-65, select Virtual Drive Management on the RAID card configuration interface, and press Enter.

❖ Figure 6-65 RAID card configuration interface

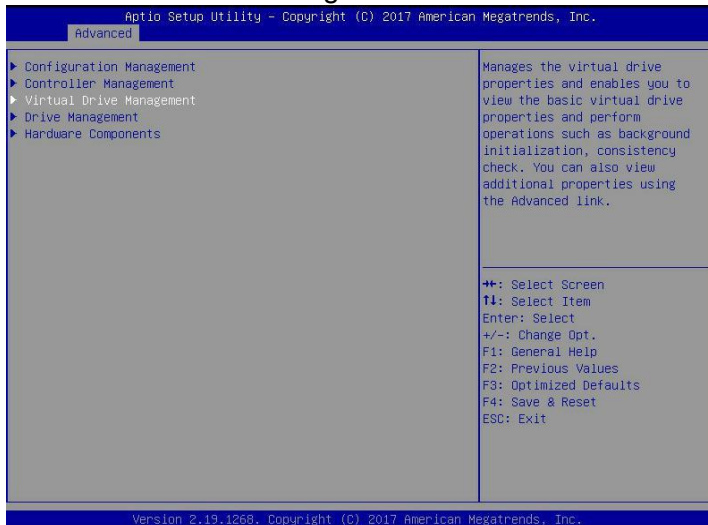

Figure 6-65

- b) Enter the interface shown in Figure 6-66, select the logical disk to be initialized, and press Enter.

❖ Figure 6-66 Logical Disk Management Interface

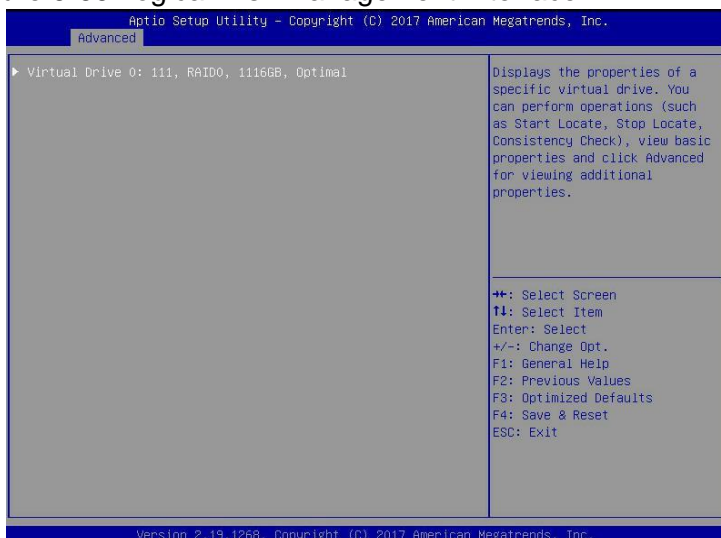

Figure 6-66

c) Enter the interface shown in Figure 6-67, select Operation, press Enter, and then select Fast/Slow Initialization in the pop-up dialog, and press Enter.

✧ Figure 6-67 Operation interface

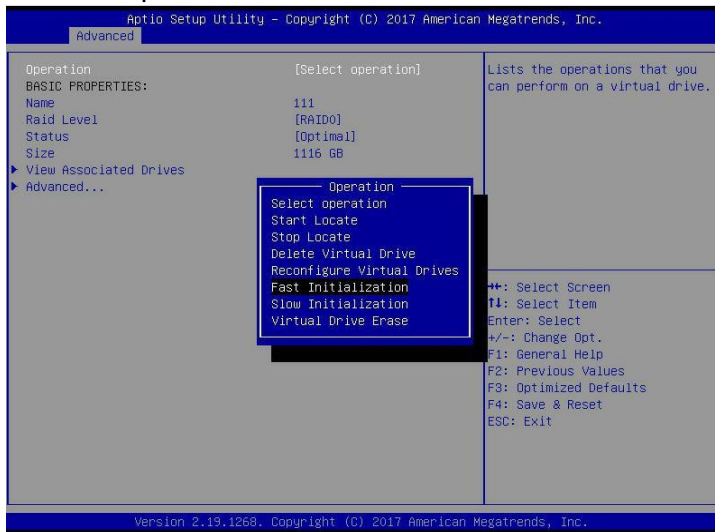
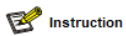

Figure 6- 67



The difference between Fast Initialization and Slow Initialization is that the former can write data immediately, while the latter needs to wait for the disk space to be initialized before writing data.

d) Enter the interface shown in Figure 6-68, select Go, and press Enter.

✧ Figure 6-68 Select Go



Figure 6- 68

e) Enter the interface shown in Figure 6-69, select Confirm to enable it, select Yes, and press Enter.

✧ Figure 6-69 Confirm initialization

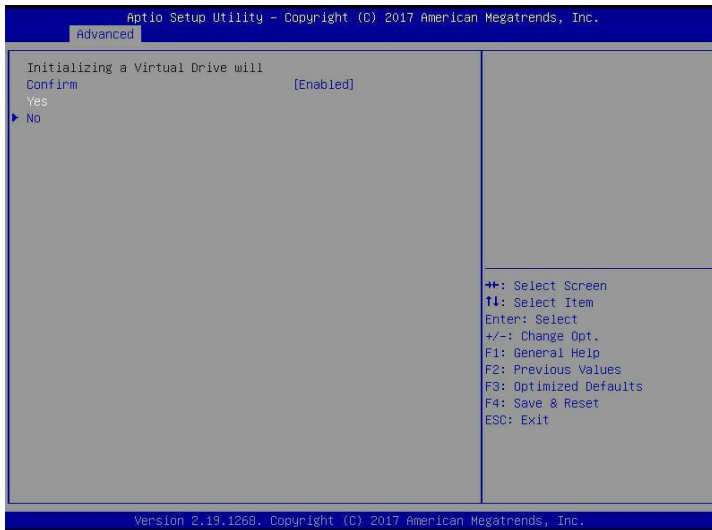

Figure 6- 69

f) Enter the interface shown in Figure 6-70 to complete the initialization of the logical disk.

✧ Figure 6-70 Finish initializing the logical disk

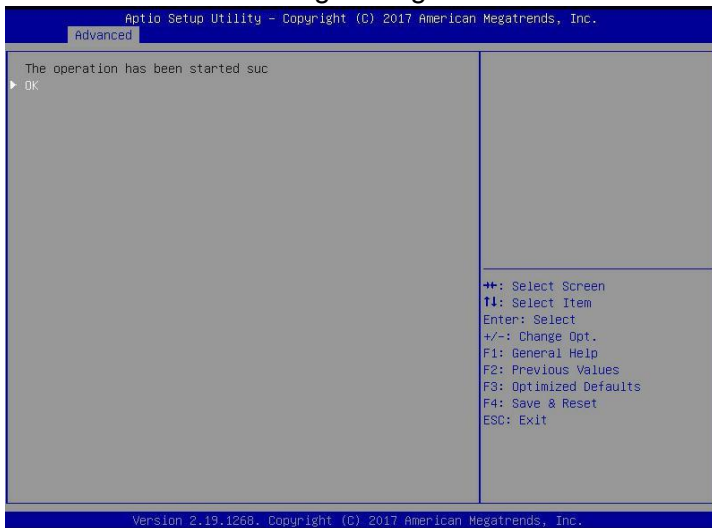

Figure 6-70

Initialize the physical disk:

a) As shown in Figure 6-71, select Drive Management on the RAID card configuration interface and press Enter.

✧ Figure 6-71 RAID card configuration interface

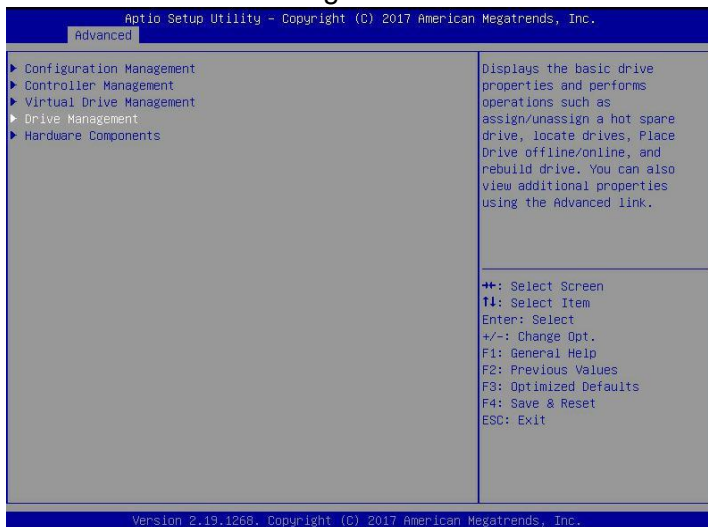

Figure 6-71

b) Enter the interface shown in Figure 6-72, select the disk to be initialized, and press Enter.

✧ Figure 6-72 Disk Management Interface

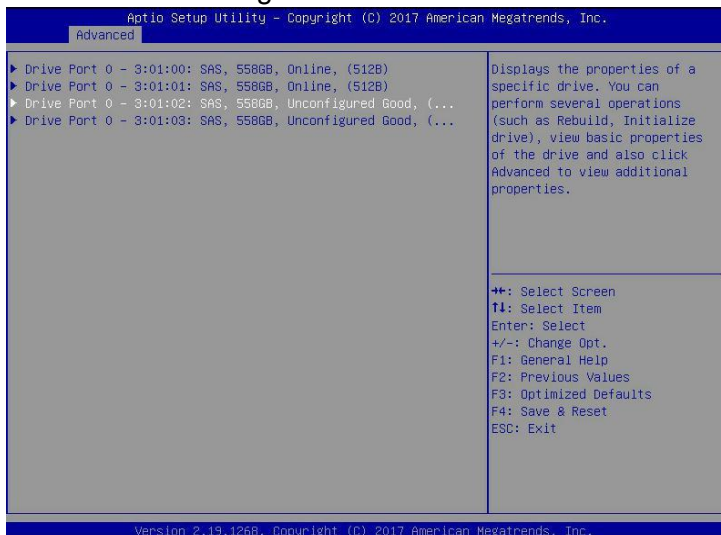

Figure 6-72

c) Enter the interface of Figure 6-73, select Operation, press Enter, and then select Initialize Drive in the pop-up dialog box, and press Enter.

✧ Figure 6-73 Operation management interface

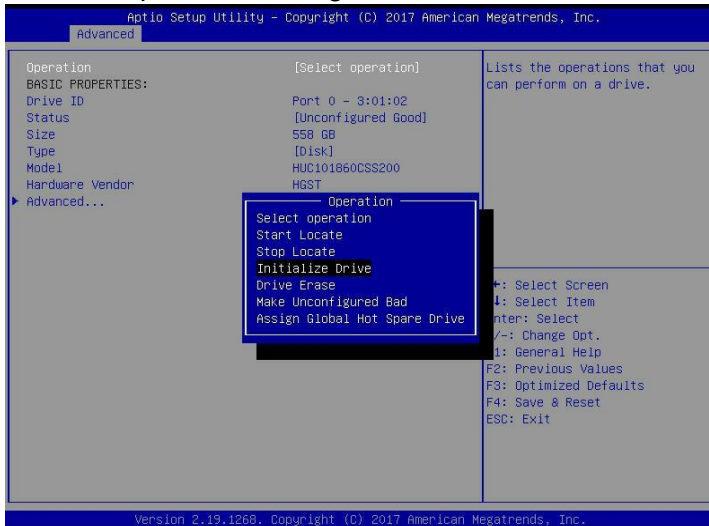

Figure 6-73

d) Enter the interface of Figure 6-74, select Go, and press Enter.

✧ Figure 6-74 Select Go



Figure 6-74

e) Enter the interface shown in Figure 6-75, select Confirm to enable it, select Yes, and press Enter.

✧ Figure 6-75 Confirm initialization

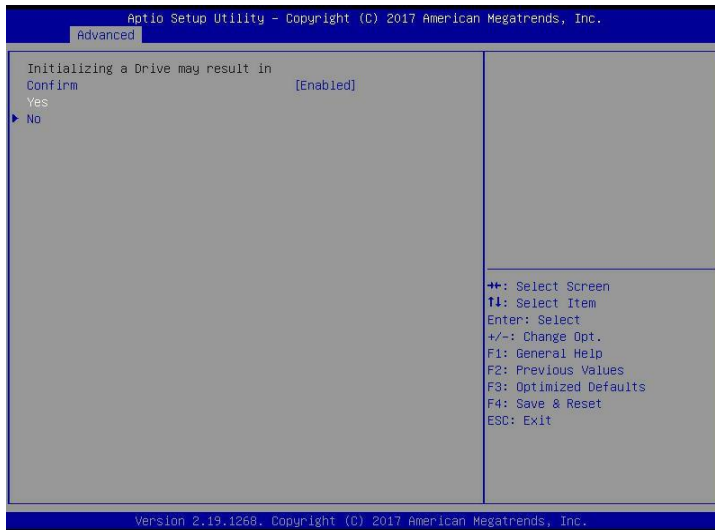

Figure 6-75

f) Enter the interface of Figure 6-76 to complete the initialization of the physical disk.

✧ Figure 6-76 Finish initializing the physical disk



Figure 6- 76

Erase disk data:

This function is used to delete internal disk data, including erasing physical disk data and logical disk data.

1. Wipe physical disk data

- a) As shown in Figure 6-77, select Drive Management on the RAID card configuration interface and press Enter.

✧ Figure 6-77 RAID card configuration interface

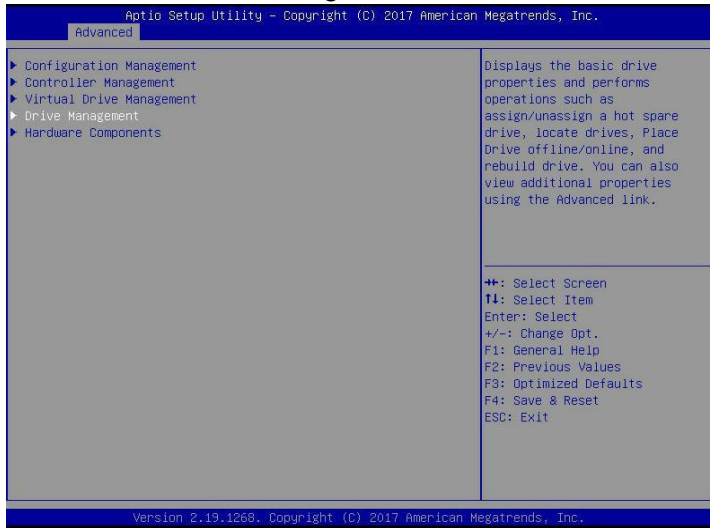

Figure 6-77

- b) Enter the interface shown in Figure 6-78, select the disk to be erased, and press Enter.

✧ Figure 6-78 Disk Management Interface

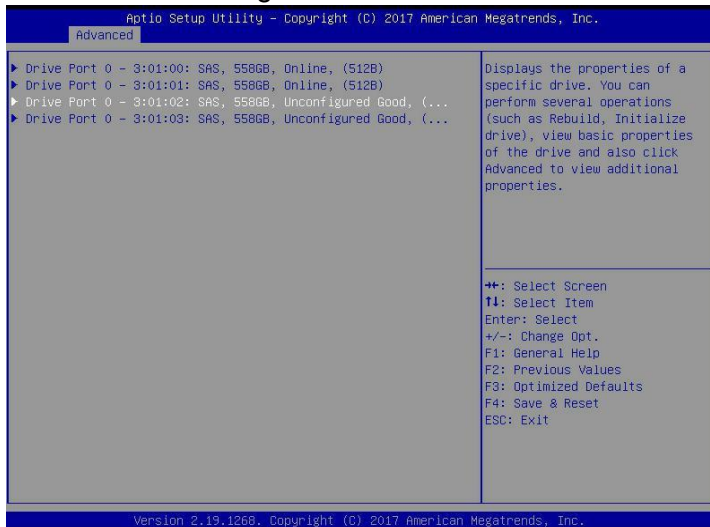

Figure 6-78

c) Enter the interface shown in Figure 6-79, select Operation, press Enter, then select Drive Erase in the pop-up dialog box, and press Enter.

✧ Figure 6-79 Operation interface

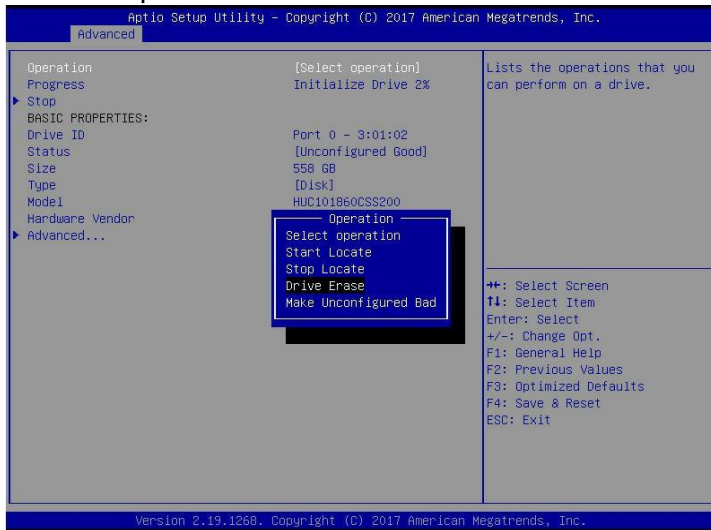

Figure 6-79

d) Enter the interface shown in Figure 6-80, press Enter, and then select the erase mode in the pop-up dialog box

(It is recommended to use the default mode: Simple).

✧ Figure 6-80 Erase Mode interface

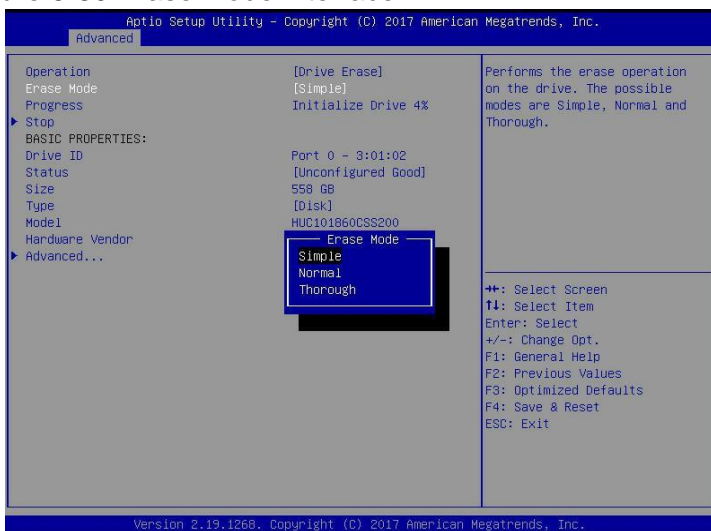

Figure 6-80

e) Enter the interface shown in Figure 6-81, select Go, and press Enter.

✧ Figure 6-81 Select Go

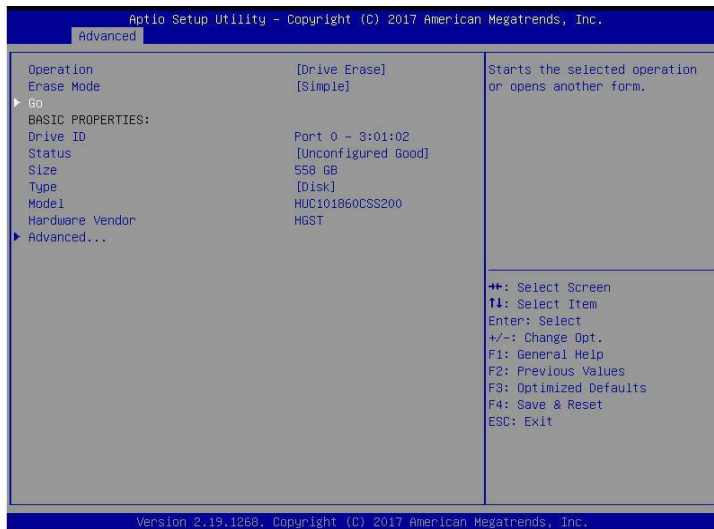

Figure 6-81

f) Enter the interface shown in Figure 6-82, select Confirm to enable it, select Yes, and press Enter.

✧ Figure 6-82 Confirm erasure

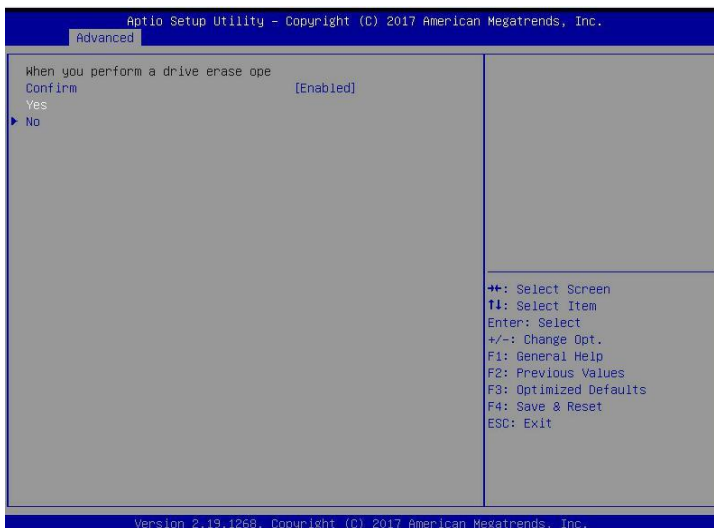



Figure 6-82

g) Enter the interface shown in Figure 6-83 to complete the operation of erasing physical disk data.

✧ Figure 6-83 Complete erasure of physical disk data



Figure 6- 83

 **Instruction** : To avoid disk failure, do not perform other operations during the erasing of physical disk data.

2. Erase logical disk data

a) As shown in Figure 6-84, select Virtual Drive Management on the RAID card configuration interface, and press Enter.

✧ Figure 6-84 RAID card configuration interface

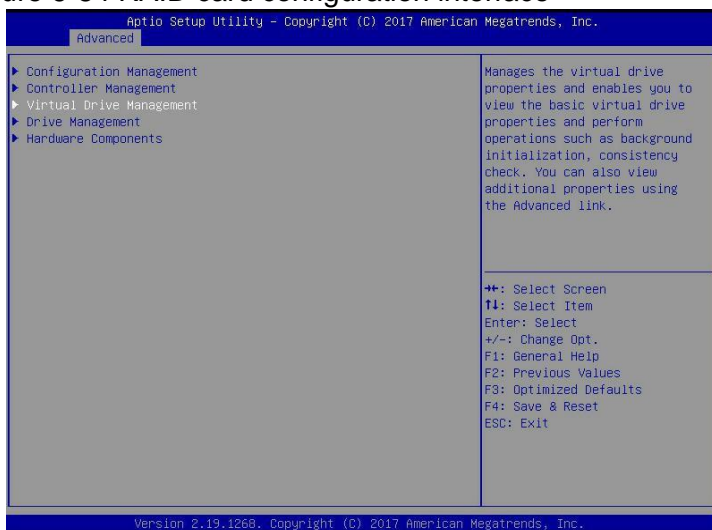

Figure 6- 84

b) Enter the interface shown in Figure 6-85, select the logical disk to be erased, and press Enter.

❖ Figure 6-85 Logical Disk Management Interface

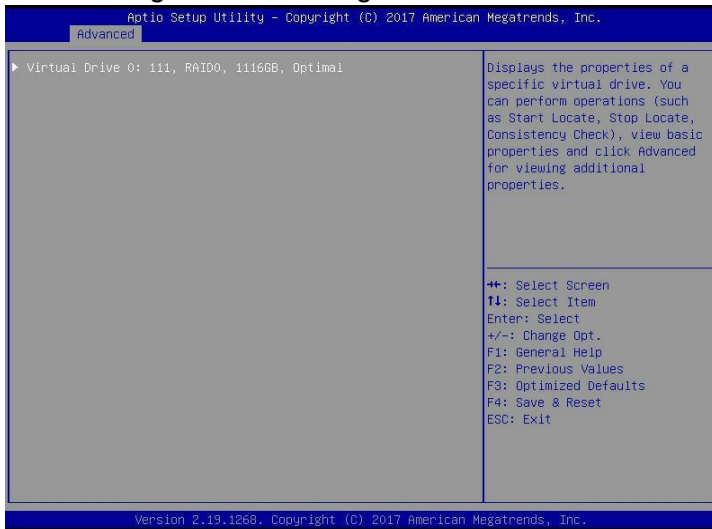

Figure 6-85

c) Enter the interface shown in Figure 6-86, select Operation, press Enter, and then select Virtual Drive Erase in the pop-up dialog box, and press Enter.

❖ Figure 6-86 Operation interface

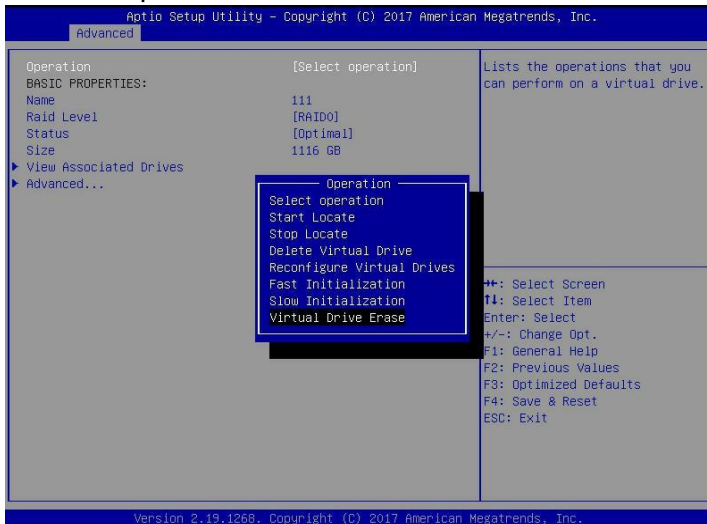

Figure 6-86

d) Enter the interface shown in Figure 6-87, press Enter, and then select the erase mode in the pop-up dialog box

(It is recommended to use the default mode: Simple).

❖ Figure 6-87 Erase Mode interface

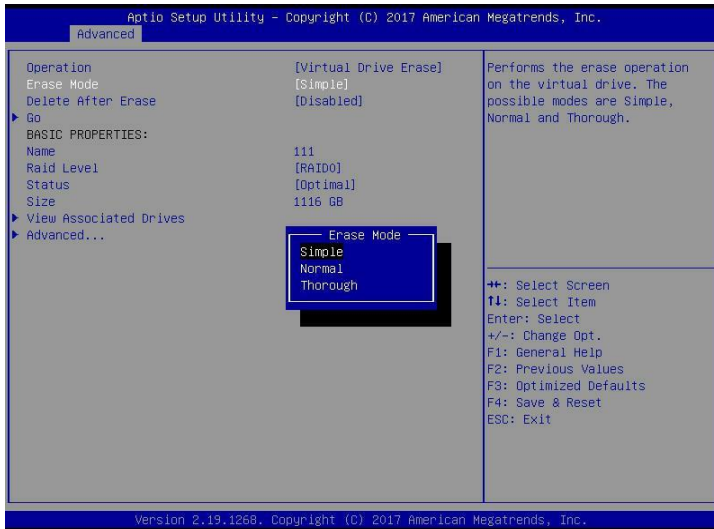

Figure 6- 87

e) Enter the interface shown in Figure 6-88, select Go, and press Enter.

❖ Figure 6-88 Select Go

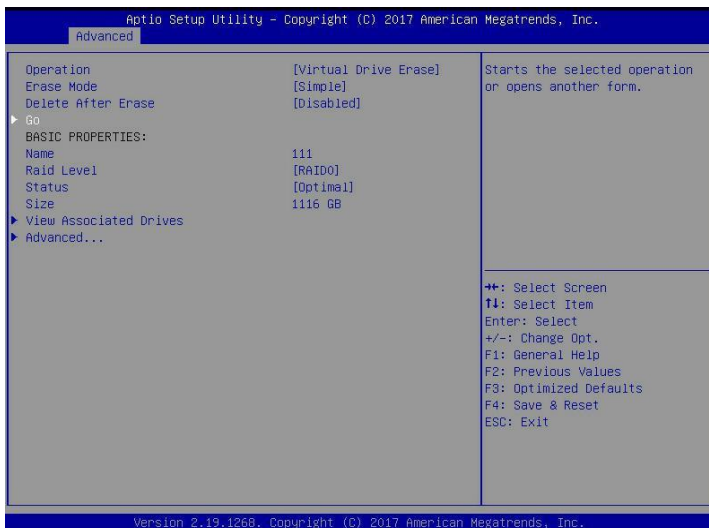

Figure 6-88

f) Enter the interface shown in Figure 6-89, select Confirm to enable it, select Yes, and press Enter.

✧ Figure 6-89 Confirm erasure

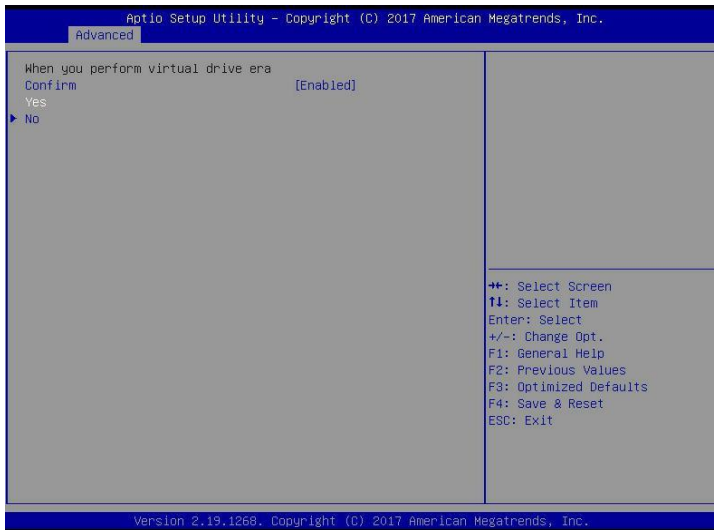

Figure 6- 89

g) Enter the interface shown in Figure 6-90 to complete the operation of erasing logical disk data.

✧ Figure 6-90 Completed erasing logical disk data

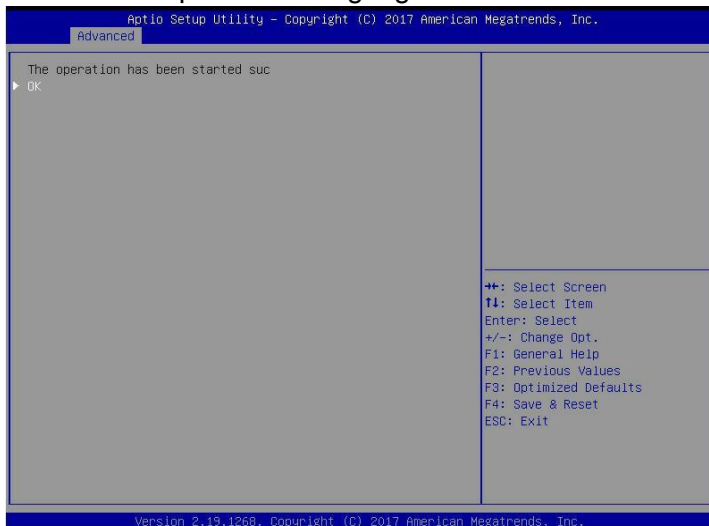

Figure 6-90

Migrate RAID level:

This function is used to modify the RAID level to meet the configuration requirements without affecting the current data integrity.

a) As shown in Figure 6-91, select Virtual Drive Management on the RAID card configuration interface, and press Enter.

❖ Figure 6-91 RAID card configuration interface

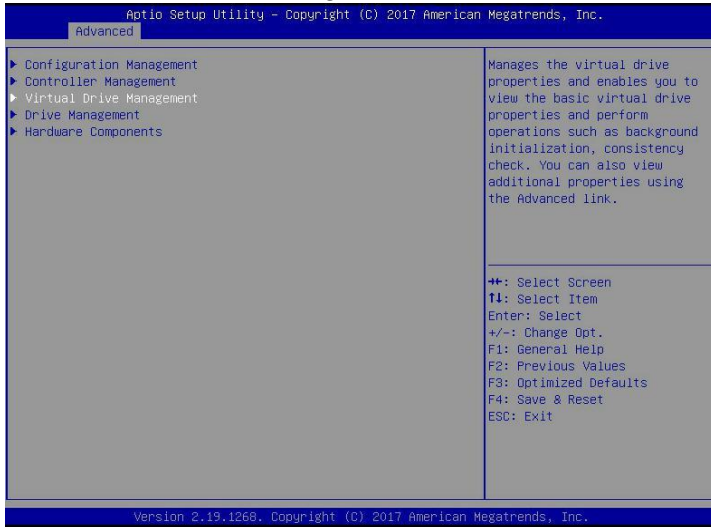

Figure 6-91

b) Enter the interface shown in Figure 6-92, select the logical disk to be rebuilt, and press Enter.

❖ Figure 6-92 Virtual Drive Management management interface

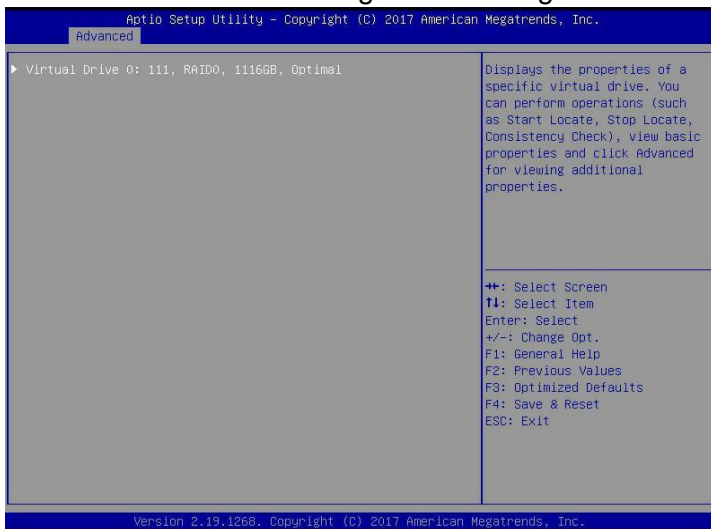

Figure 6- 92

c) Enter the interface shown in Figure 6-93, select Operation, press Enter, and then select Reconfigure Virtual Drive in the pop-up dialog box, and press Enter.

✧ Figure 6-93 Operation interface

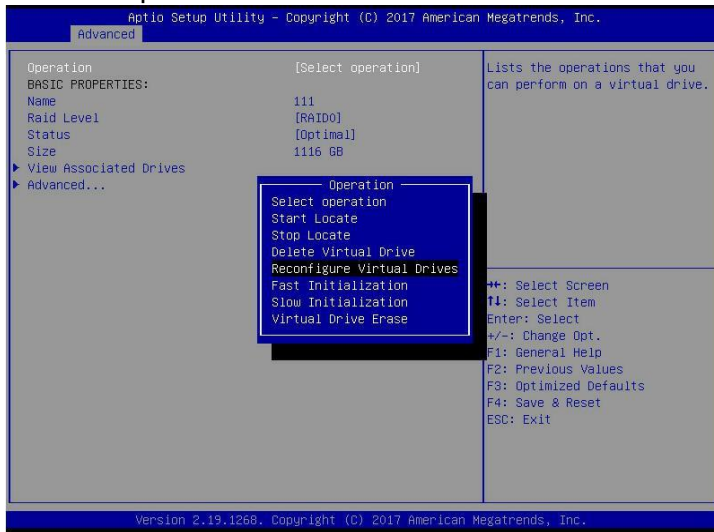

Figure 6-93

d) Enter the interface shown in Figure 6-94, select Go, and press Enter.

✧ Figure 6-94 Select Go



Figure 6-94

e) Enter the interface shown in Figure 6-95, set the RAID level, select Add Drives, and press Enter.

✧ Figure 6-95 Advanced interface

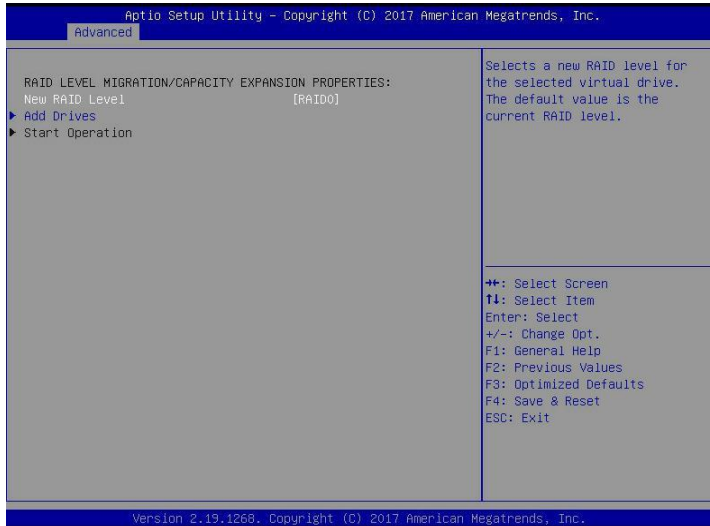

Figure 6- 95

f) Enter the interface shown in Figure 6-96, select the disk to be added, make it Enabled, select Apply Changes, and press Enter.

✧ Figure 6-96 Add Drives interface

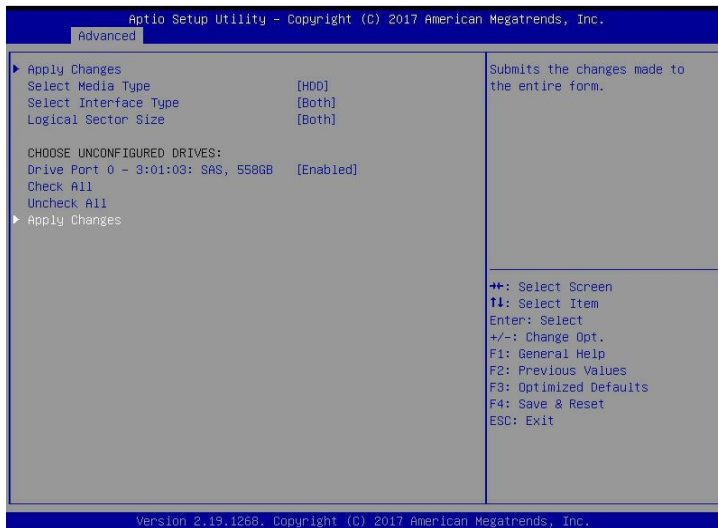

Figure 6- 96

g) Enter the interface shown in Figure 6-97, select Confirm to enable it, select Yes, and press Enter.

✧ Figure 6-97 Confirm migration

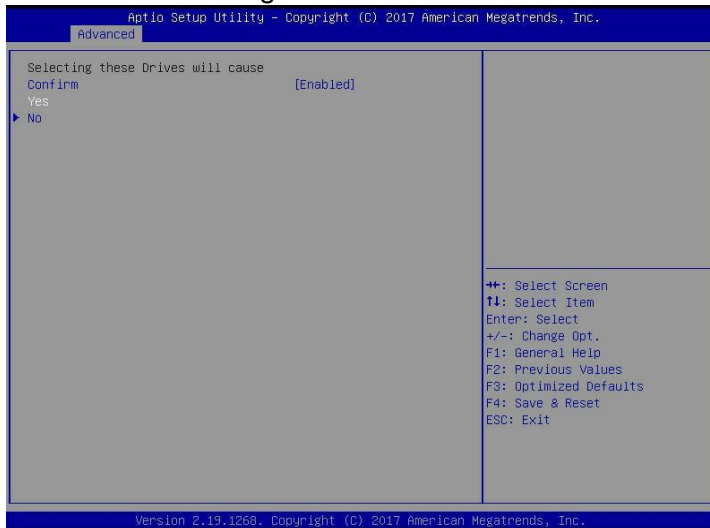

Figure 6- 97

h) Enter the interface shown in Figure 6-98, select Start Operation, and press Enter.

✧ Figure 6-98 Start Operation interface

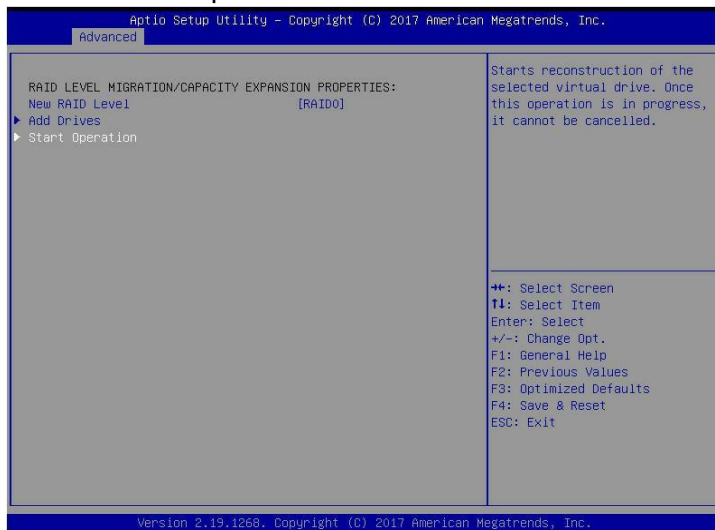

Figure 6- 98

i) Enter the interface shown in Figure 6-99, select OK, and press Enter.

✧ Figure 6-99 Select OK

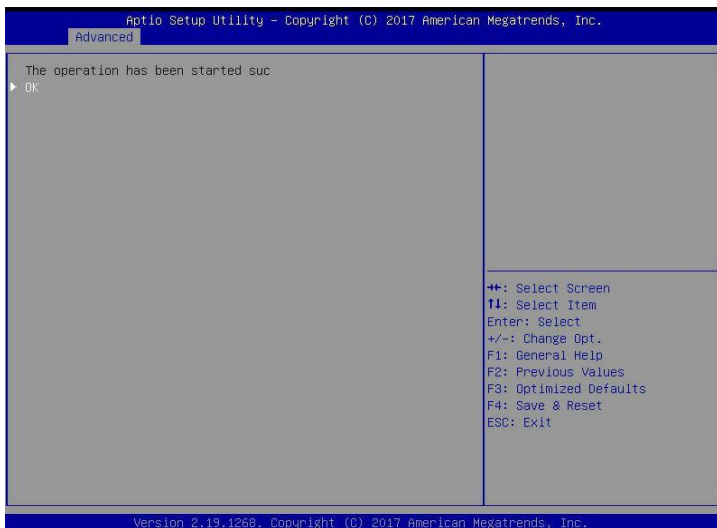

Figure 6-99

j) Enter the interface shown in Figure 6-100 to view the current migration progress.

✧ Figure 6-100 RAID information interface

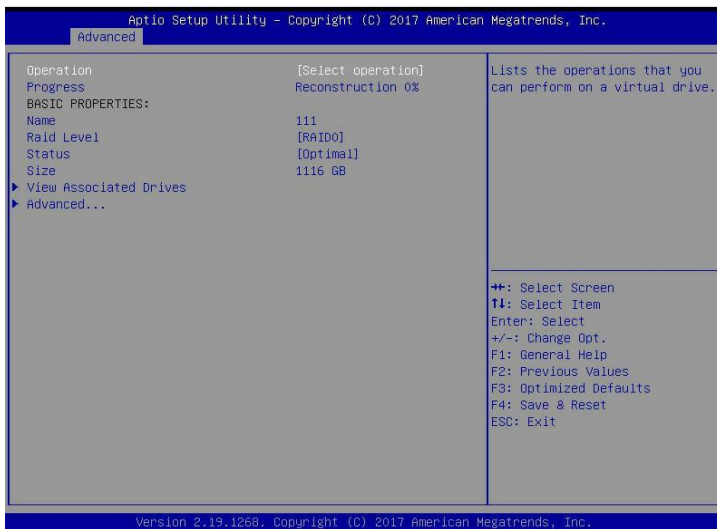

Figure 6- 100

Clear disk RAID information:

This function is used to clear the residual RAID information in the disk, so that the disk can be reused to configure RAID. This function is often used for disks whose mode is Unconfigured Bad.

- a) Switch the disk mode Unconfigured Bad to Unconfigured Good.
- b) As shown in Figure 6-101, select Configuration Management on the RAID card configuration interface, and press Enter.

✧ Figure 6-101 RAID card configuration interface

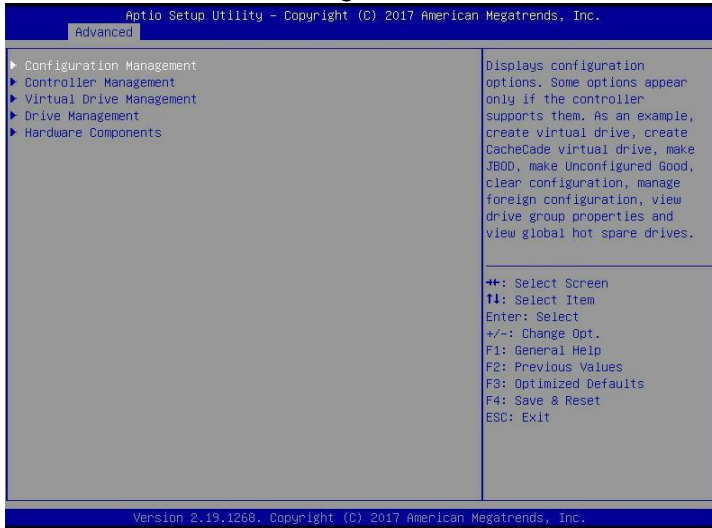

Figure 6-101

- c) Enter the interface shown in Figure 6-102, select Manage Foreign Configuration, and press Enter.

✧ Figure 6-102 Select Manage Foreign Configuration

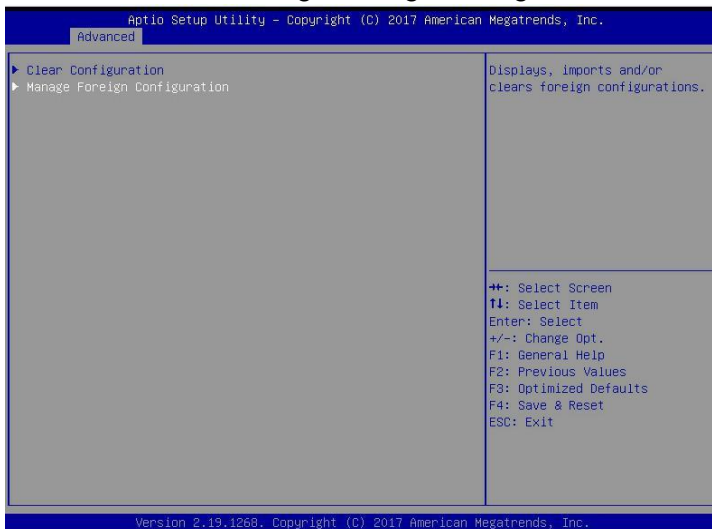

Figure 6- 47

d) Enter the interface shown in Figure 6-103, select Clear Foreign Configuration, and press Enter.

✧ Figure 6-103 Select Clear Foreign Configuration

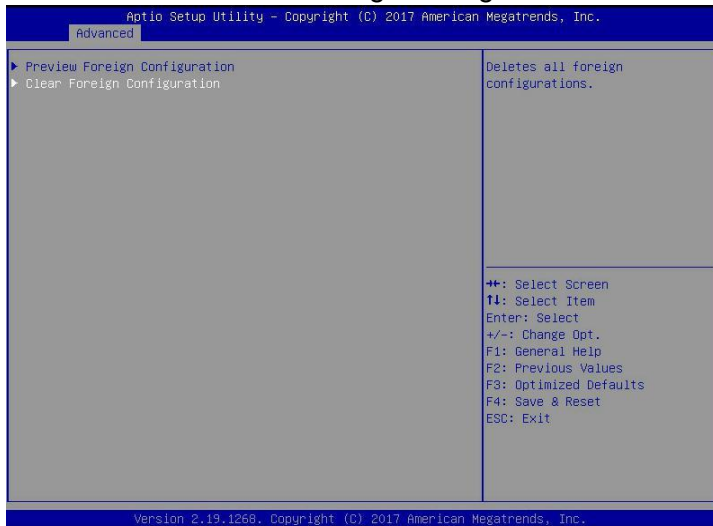

Figure 6-48

e) Enter the interface shown in Figure 6-104, select Confirm to enable it, select Yes, and press Enter.

✧ Figure 6-104 Confirm clear

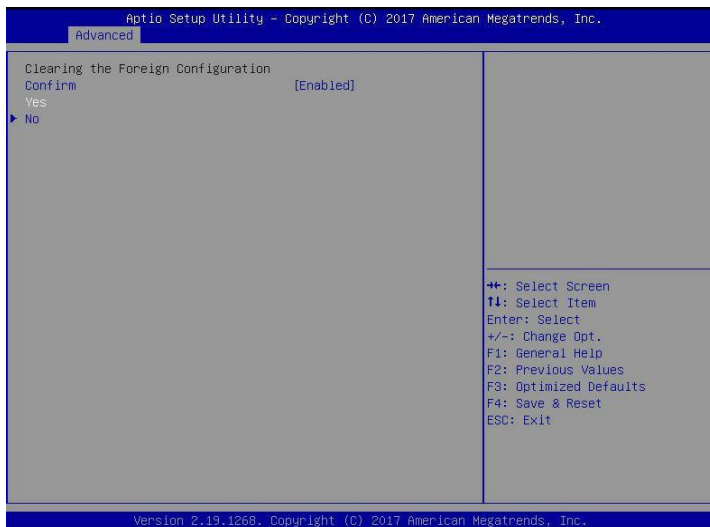

Figure 6-49

f) Enter the interface shown in Figure 6-105 to complete the operation of clearing disk RAID information.

✧ Figure 6-105 Complete clearing disk RAID



Figure 6- 105

6.2.2 Configure RAID in Legacy Boot Mode

➤ Enter the RAID card configuration interface

a) During the BIOS startup process, after the interface shown in Figure 6-105 appears, press Ctrl+R.

✧ Figure 6-106 Press Ctrl+R as prompted during BIOS startup

```
AVAGO MegaRAID SAS-MFI BIOS
Version 6.31.03.0 (Build January 25, 2016)
Copyright(c) 2016 AVAGO Technologies
F/W Initializing Devices 100%
HA -0 (Bus 2 Dev 0) AVAGO MegaRAID SAS 9361-8i
Battery Status: Missing
PCI Slot Number: 4

ID LUN VENDOR  PRODUCT                REVISION  CAPACITY
-----
00 0  AVAGO  AVAGO MegaRAID SAS 9361-8i  4.650.00-6121  1024MB
08 0  ATA    MM1000GBKAL             HPGC      953869MB
1030 ATA    MM1000GBKAL             HPGC      953869MB
1040 ATA    MM1000GBKAL             HPGC      953869MB
1200 HP     EG0300FBVFL             HPDC      206102MB
1290 HP     EG0300FCUBF             HPDS      206102MB
1300 HP     EG0300FBVFL             HPDC      206102MB
  0  AVAGO  Virtual Drive            RAID0     5120MB

1 Virtual Drive(s) found on the host adapter.
1 Virtual Drive(s) handled by BIOS

Press <Ctrl><R> to Run MegaRAID Configuration Utility
```

Figure 6- 106

b) Enter the interface shown in Figure 6-107. Please refer to the key operation tips at the lower border of the interface and modify settings in the interface.

✧ Figure 6-107 LSI RAID management interface

```
VD Mgmt  PD Mgmt  Ctrl Mgmt  Properties
-----
Virtual Drive Management
[-] LSI MegaRAID 9361-8i (Bus 8x02, Dev 8x00)
  No Configuration Present !
  [-] Unconfigured Drives
    |--:00: Ready: 278.07 GB
    |--:01: Ready: 278.07 GB
    |--:04: Ready: 278.07 GB
    |--:05: Ready: 278.07 GB
    |--:06: Ready: 278.07 GB
    |--:07: Ready: 931.00 GB

Controller:
Drive Groups: 0
Virtual Drives: 0
Drives: 6

F1-Help F2-Operations F5-Refresh Ctrl-N-Next Page Ctrl-P-Prev Page F12-Ctrl
```

Figure 6- 50

➤ Common tasks

Configure RAID:

c) As shown in Figure 6-108, press F2 on the VD Mgmt interface and select Create Virtual Drive.

✧ Figure 6-108 Select Create Virtual Drive

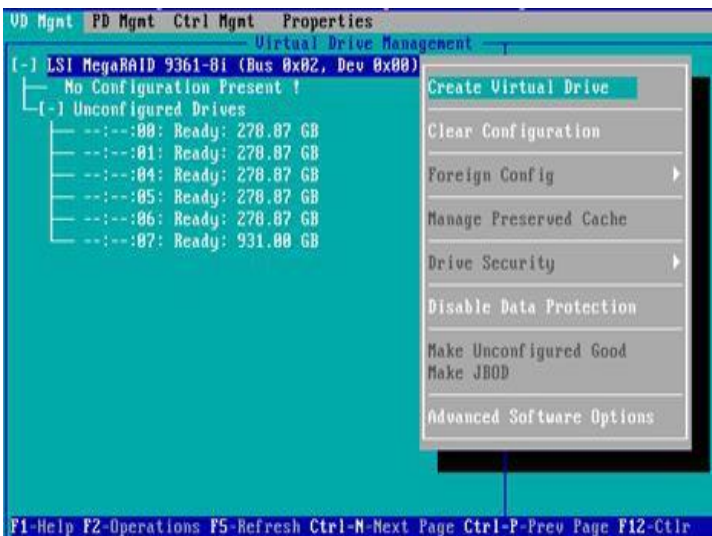

Figure 6-51

d) Enter the interface shown in Figure 6-109, set the RAID level, and press Enter.

✧ Figure 6-109 Set RAID level



Figure 6-52

e) Enter the interface shown in Figure 6-110, select the disk used to configure RAID, and press Enter.

✧ Figure 6-110 Select Disk



Figure 6-53

f) Enter the interface shown in Figure 6-111, set the Size and Name accordingly, then select Advanced, and press Enter.

✧ Figure 6-111 Set RAID name and capacity



Figure 6-54

g) Enter the interface shown in Figure 6-112, set the relevant parameters, then select OK, and press Enter.

✧ Figure 6-112 Set advanced parameters



Figure 6-55

h) Enter the interface shown in Figure 6-113, select OK, and press Enter to complete the RAID configuration operation.

✧ Figure 6-113 Confirm creation



Figure 6- 56

i) Select the RAID to be viewed and press Enter to view the detailed information of the RAID (including RAID name, level, and disk information, etc.), as shown in Figure 6-114.

✧ Figure 6-114 View RAID information

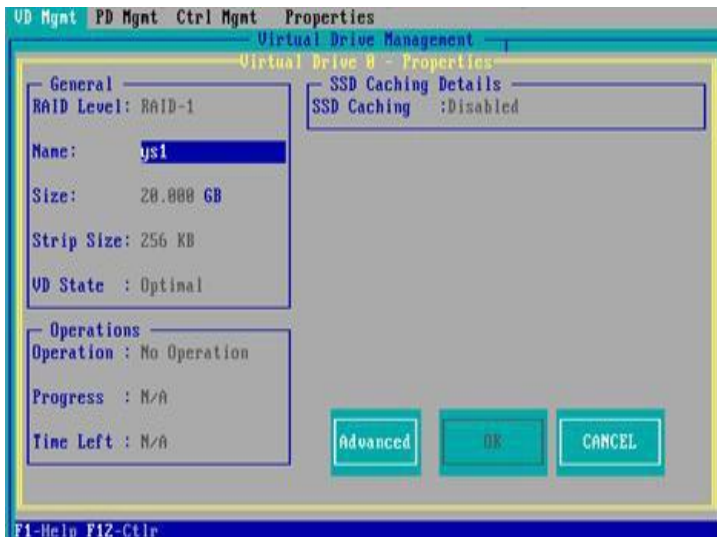
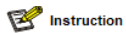

Figure 6-57

Configure hot spare disk:

After RAID is configured, hot spare disks are generally configured to improve data security. You can configure global hot spare disks and dedicated hot spare disks as needed.



- ❖ Hot spare disks are only available for RAID levels with redundancy.
- ❖ The capacity of the hot spare disk is larger than the capacity of a single member disk of the RAID to contribute to the RAID.
- ❖ Only the disk whose configuration mode is Unconfigured Good is supported as a hot spare disk.

1. Configure global hot spare disk

a) As shown in Figure 6-115, select the disk to be configured as a global hot spare on the PD Mgmt interface, and press F2.

- ❖ Figure 6-115 Select the disk to be configured as a global hot spare disk

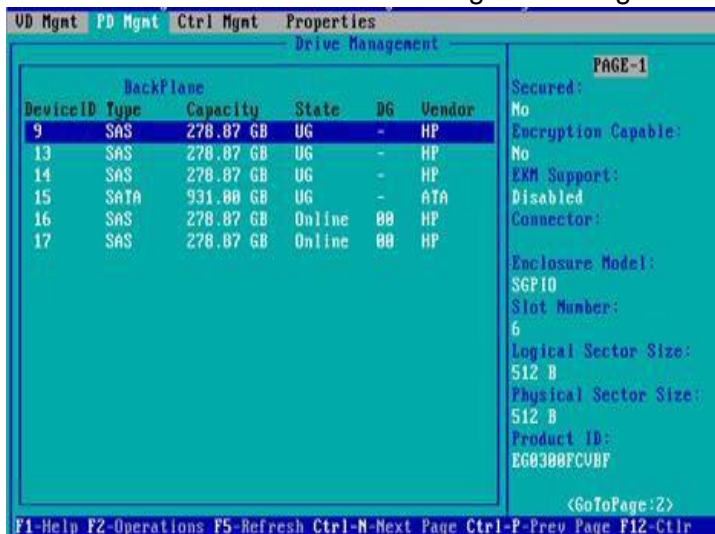

Figure 6- 58

b) Enter the interface shown in Figure 6-116, select Make Global HS, and press Enter to complete the configuration of the global hot spare disk.

- ❖ Figure 6-116 Select Make Global HS



Figure 6-59

c) Return to the interface shown in Figure 6-117, select the hot spare disk to view the related information of the global hot spare disk.

✧ Figure 6-117 View global hot spare disk information

The screenshot displays a 'Drive Management' window with a 'BackPlane' table and a 'Properties' section. The table lists five disks, with the first one (DeviceID 9) highlighted as a 'Hotspare'. The properties section on the right provides details for the selected disk, including its security status, encryption capabilities, and physical characteristics.

DeviceID	Type	Capacity	State	DG	Vendor
9	SAS	278.87 GB	Hotspare	-	HP
13	SAS	278.87 GB	UG	-	HP
14	SAS	278.87 GB	UG	-	HP
15	SATA	931.00 GB	UG	-	ATA
16	SAS	278.87 GB	Online	00	HP
17	SAS	278.87 GB	Online	00	HP

Properties

PAGE-1

Secured: No
Encryption Capable: No
ERM Support: Disabled
Connector:
Enclosure Model: SGFI0
Slot Number: 6
Logical Sector Size: 512 B
Physical Sector Size: 512 B
Product ID: EG0300FCU0F

<GoToPage:2>

F1-Help F2-Operations F5-Refresh Ctrl-N-Next Page Ctrl-P-Prev Page F12-Ctrl

Figure 6- 60

Delete RAID:

This function is used to delete the damaged or hard to meet the demand of RAID.

a) As shown in Figure 6-118, select the logical disk to be deleted on the VD Mgmt interface, and press F2.

✧ Figure 6-118 Select the logical disk to be deleted



Figure 6-118

b) Enter the interface shown in Figure 6-119, select Delete VD, and press Enter.

✧ Figure 6-119 Select Delete VD

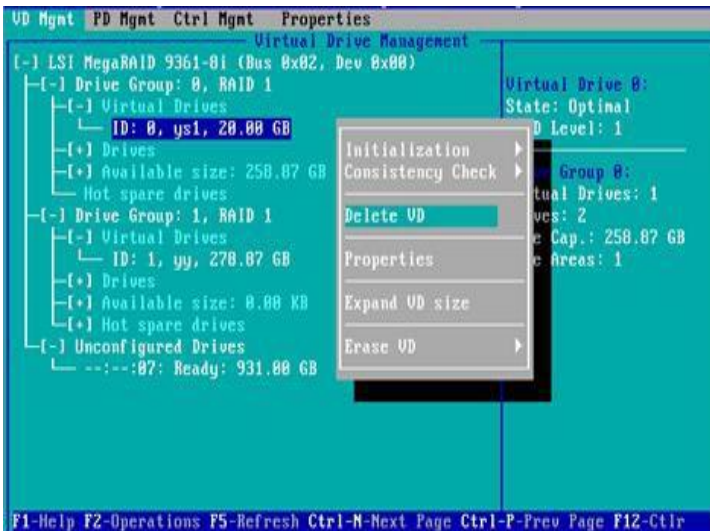

Figure 6-61

c) Enter the interface shown in Figure 6-120, select YES, and press Enter to complete the RAID deletion operation.

✧ Figure 6-120 Confirm delete

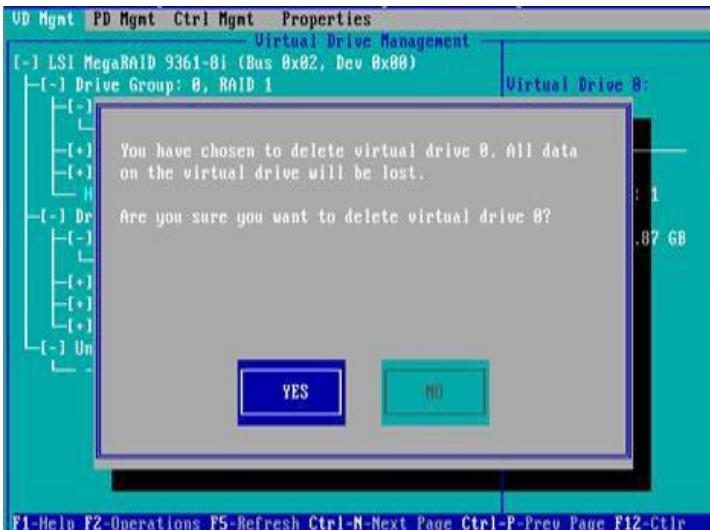

Figure 6- 120

Locate the disk location:

This function is convenient for you to find the disk quickly by lighting the blue indicator of the corresponding slot of the disk. A single physical disk or all member disks included in a logical disk can be located.

a) As shown in Figure 6-121, select the disk to be located on the PD Mgmt interface and press F2.

✧ Figure 6-121 Select the disk to be located

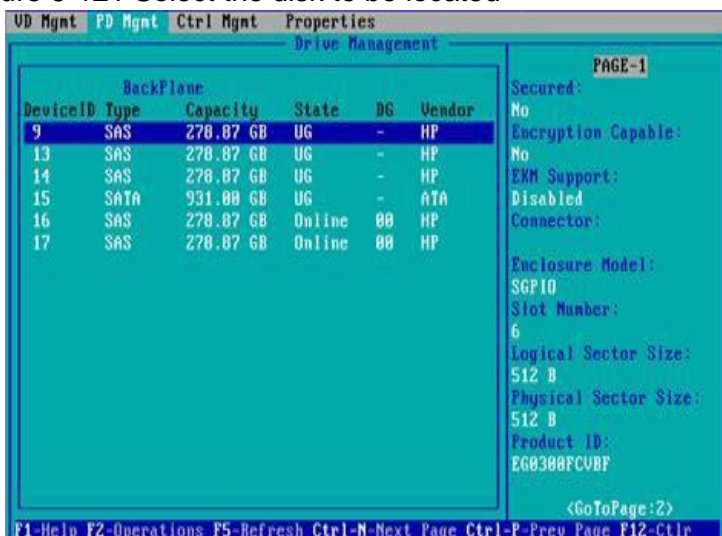

Figure 6- 62

b) Enter the interface shown in Figure 6-122 and select Locate->Start to complete the disk positioning operation.

✧ Figure 6-122 Select Locate-> Start

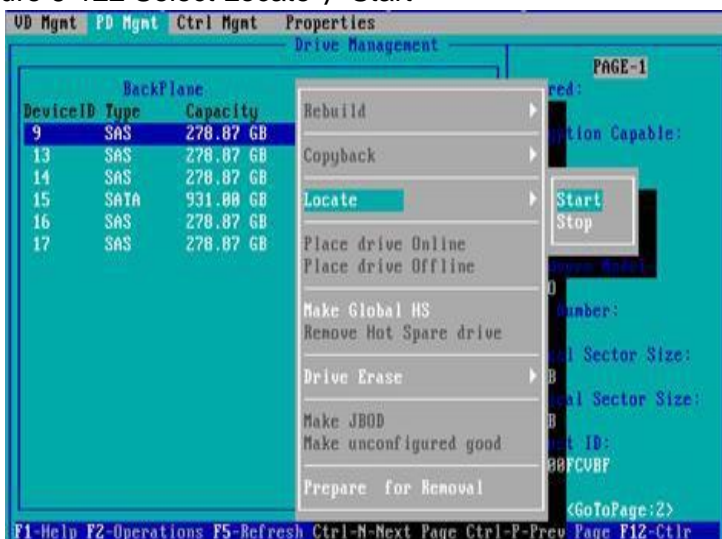

Figure 6-63



Instruction

- ✧ Locate->Start: Start the disk positioning operation.
- ✧ Locate->Stop: Stop positioning the disk operation.

Initialize the logical disk:

This function is used to initialize the internal data space of the disk so that it can be recognized and used by the operating system.

a) As shown in Figure 6-123, select the disk to be initialized on the VD Mgmt interface and press F2.

✧ Figure 6-123 Select the disk to be initialized



Figure 6-64

b) Enter the interface shown in Figure 6-124 and select Initialization->Start FGI.

✧ Figure 6-124 Select Initialization-> Start FGI

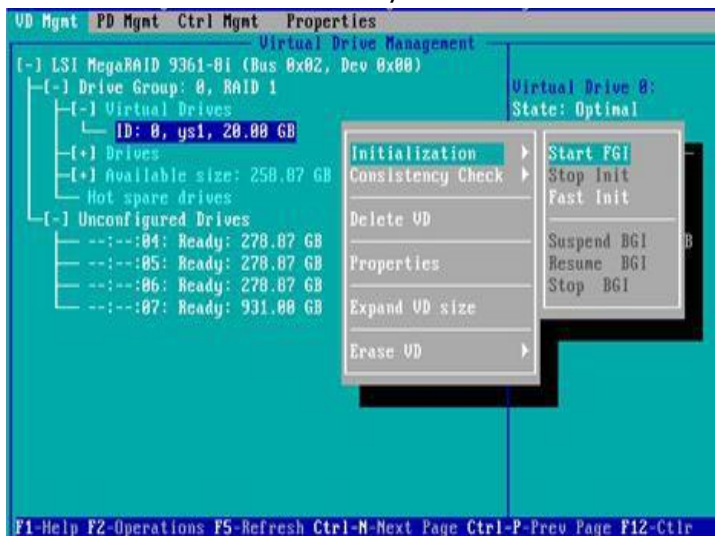
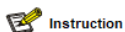

Figure 6-65



Instruction

- ✧ BGI: Background Initialization, background initialization, first initialize part of the RAID space for writing data, and the remaining space is initialized in the background.
- ✧ FGI: Full Groud Initialization, full disk initialization, initialize all the space of the RAID, and write data after the initialization is completed.

c) Enter the interface shown in Figure 6-125, select YES, and press Enter to complete the initialization disk operation.

✧ Figure 6-125 Confirm initialization

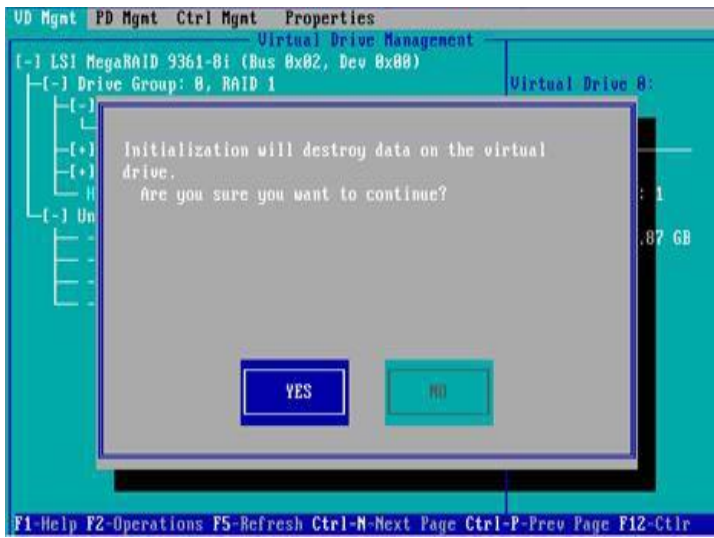

Figure 6-66

Erase disk data:

This function is used to delete internal disk data, including erasing physical disk data and logical disk data.

1. Wipe physical disk data

a) As shown in Figure 6-126, select the physical disk to be erased on the PD Mgmt interface and press F2.

✧ Figure 6-126 Select the physical disk to be erased

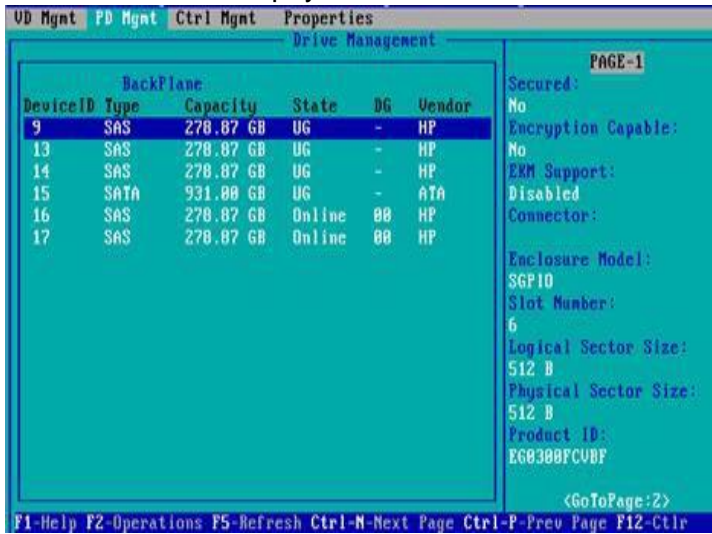

Figure 6- 67

b) Enter the interface shown in Figure 6-127, select the erasing mode (the default mode is recommended: Simple), and press Enter.

✧ Figure 6-127 Select erasing mode



Figure 6- 68

c) Enter the interface shown in Figure 6-128, select Yes, and press Enter to complete the operation of erasing physical disk data.

✧ Figure 6-128 Confirm erasure



Figure 6- 69

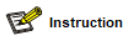

To avoid disk failure, please do not perform other operations during the erasing of physical disk data.

2. Erase logical disk data

a) As shown in Figure 6-129, select the logical disk to be erased on the VD Mgmt interface and press F2.

✧ Figure 6-129 Select the logical disk to be erased.



Figure 6-70

b) Enter the interface shown in Figure 6-130, select the erase mode (the default mode is recommended: Simple), and press Enter.

❖ Figure 6-130 Select erasing mode



Figure 6-71

c) Enter the interface shown in Figure 6-131, select Yes, and press Enter to complete the operation of erasing logical disk data.

❖ Figure 6-131 Confirm erasure



Figure 6-72

Clear disk RAID information:

This function is used to clear the residual RAID information in the disk, so that the disk can be reused to configure RAID. This function is often used for disks whose mode is Unconfigured Bad.

- Switch the disk mode Unconfigured Bad to Unconfigured Good.
- As shown in Figure 6-132, in the Foreign View interface, select the RAID card, press F2, select Foreign Config->Clear, and press Enter.

✧ Figure 6-132 Select Foreign Config->Clear



Figure 6-73

- In the pop-up dialog box shown in Figure 6-133, select OK and press Enter to complete the operation of clearing the disk RAID information.

✧ Figure 6-133 Confirm clear



Figure 6-74

Chapter 7 IPMI Rapid Deployment

7.1 Rapid deployment of IPMI process

How to quickly deploy the IPMI function of the server, the approximate process is shown in Figure 7-1.

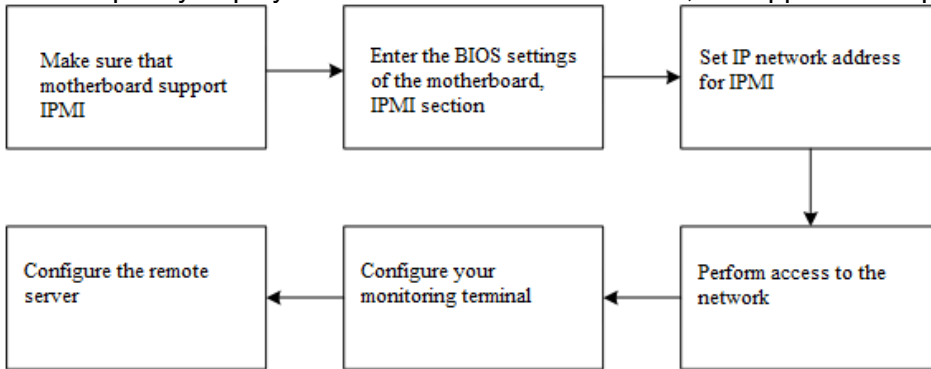
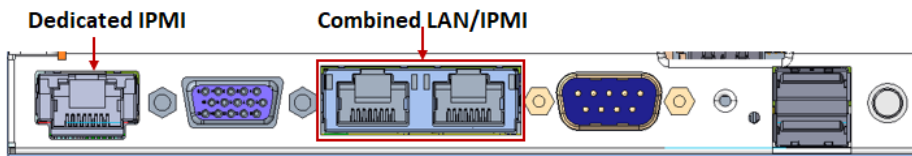

Figure 7-1 IPMI deployment process

7.1.1 Make sure the motherboard supports IPMI function



and confirm that your motherboard supports IPMI, then find the dedicated IPMI network port for the motherboard, or you can choose to share the network port, as shown in Figure 7-2.

Figure 7-2 Main board dedicated network port

7.1.2 Enter BIOS to set IPMI function

Restart your system and press ESC or DEL to enter the motherboard BIOS system while the device is booting. The BIOS setting interface is shown in Figure 7-3.

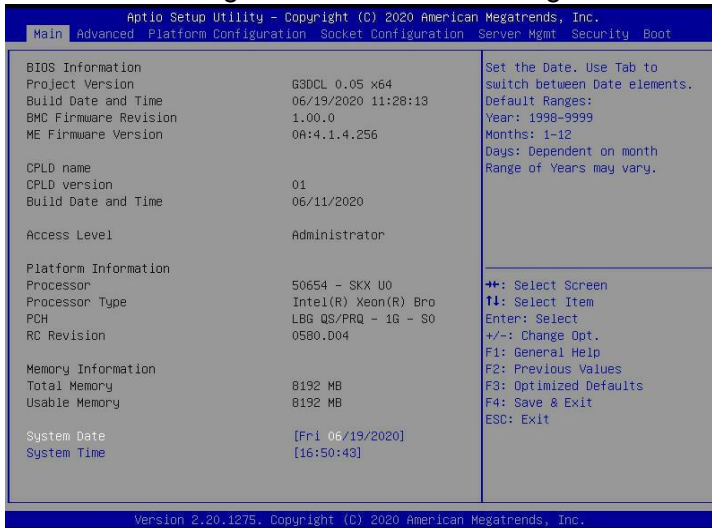

Figure 7-3 Mainboard BIOS setting interface

After entering this interface, use the left and right keys of the keyboard to switch the menu item to the Server Mgmt option, and you will see the page shown in Figure 7-4.



Figure 7-4 Server Mgmt interface

After entering this interface, enter the BMC network configuration option through the keyboard, and you will enter the following interface, as shown in Figure 7-5.

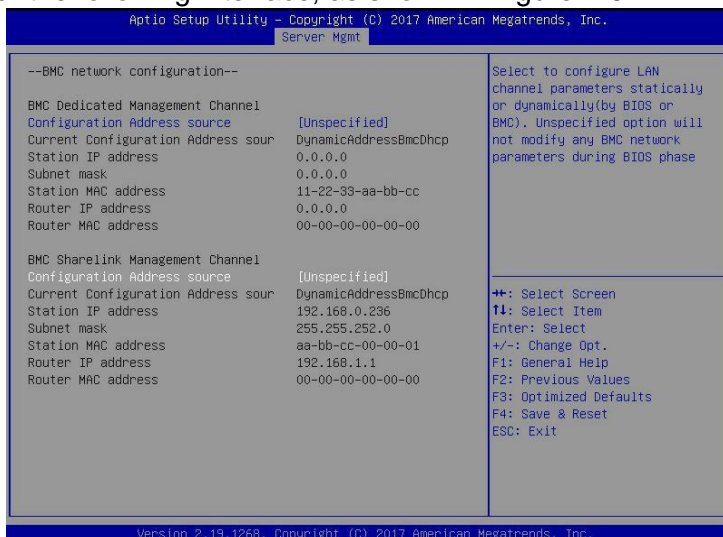

Figure 7-5 BMC network configuration option interface

On this page, you can see two configurable network ports, one is Dedicated dedicated network port, and the other is Sharelink shared network port. Take the shared network port as an example here. If you connect a dedicated network port, the setting method is the same as the shared network port. Switch to the Configuration Address Source option and press Enter to set the network mode of changing the network port, as shown in Figure 7-6.

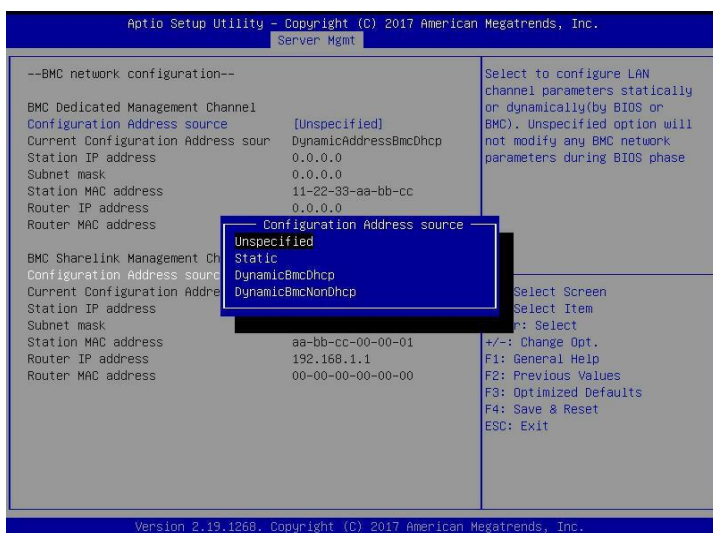

Figure 7-6 Configure network port network mode

There are four network modes that can be configured on this interface, namely Unspecified, Static, DynamicBMCDHCP, DynamicBMCNonDHCP. Static is the static mode, you can manually set the IP address, and DHCP is the dynamic mode. Setting this option allows BMC to automatically obtain an IP address from the DHCP server.

7.1.3 IPMI interface configuration Static mode

If you choose to configure Static mode for the IPMI interface, you should pay attention to the following issues:

- (1) If there are multiple IPMI devices in your local area network, please note that the IP addresses between the devices cannot be repeated, otherwise communication cannot be established.
- (2) If the IP of your IPMI device is an intranet address, the terminal device communicating with it must be in the same network segment as the IPMI device address.
- (3) The IP address of the IPMI device can be mapped to the WAN through the routing device for remote management.
- (4) The IPMI port has the function of obtaining an IP address through DHCP.
- (5) IPMI supports two protocols, TCP/IP v4 and TCP/IP v6.

Configure the IP address and subnet mask according to your actual situation. For example, here we set the IP address to 192.168.0.236 and the subnet mask to 255.255.252.0, as shown in Figure 7-7 below. After setting, press F4 to save and exit the BIOS interface.

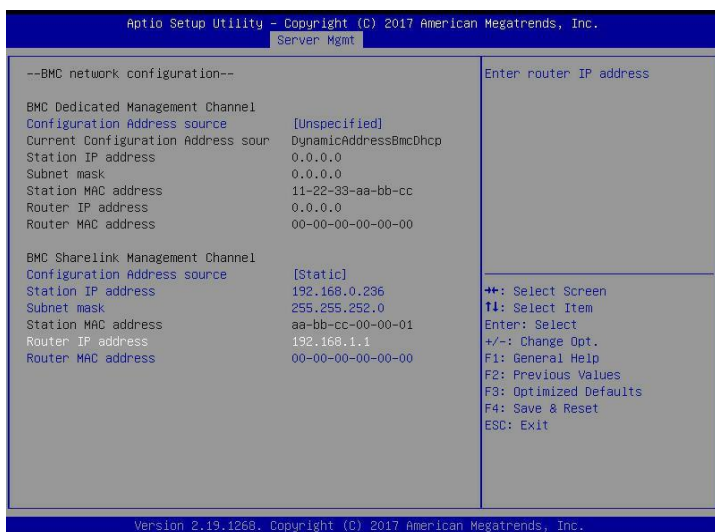

Figure 7-7

7.1.4 IPMI configuration Java SOL

1. Press the key when the system starts to enter the BIOS setting interface.
2. Switch to the Advanced menu, select Serial Port Console Redirection, and press <Enter> key.
3. Make sure that the Console Redirection of COM0 is in the [Enabled] state, if not, select Console Redirection, and then press the <Enter> key to set the state to [Enabled]. To ensure the normal operation of iBMC, this option has been set to [Enabled] by default.

7.2 IPMI function quick start instructions

After completing the previous configuration steps, we can start to log in to the IPMI management interface. The IPMI management interface can be accessed using a standard web browser. Here we recommend using Google Chrome browser, Firefox Firefox browser, and IE browser. Browser (IE 11 and above) to get the best browsing experience. Since the new version of the operation interface is based on HTML5, it costs a lot of computer resources. We recommend that the client configure more than 8G of memory when using KVM.

7.2.1 Enter the operation interface

Take the Google Chrome browser as an example. Enter the IPMI access address in the address bar of the browser and press Enter to access the IPMI management interface. Since all HTTP links have been converted to HTTPS encrypted links, it will enter as shown in Figure 7-8. The privacy setting error page shown, the content of other browsers may be different.

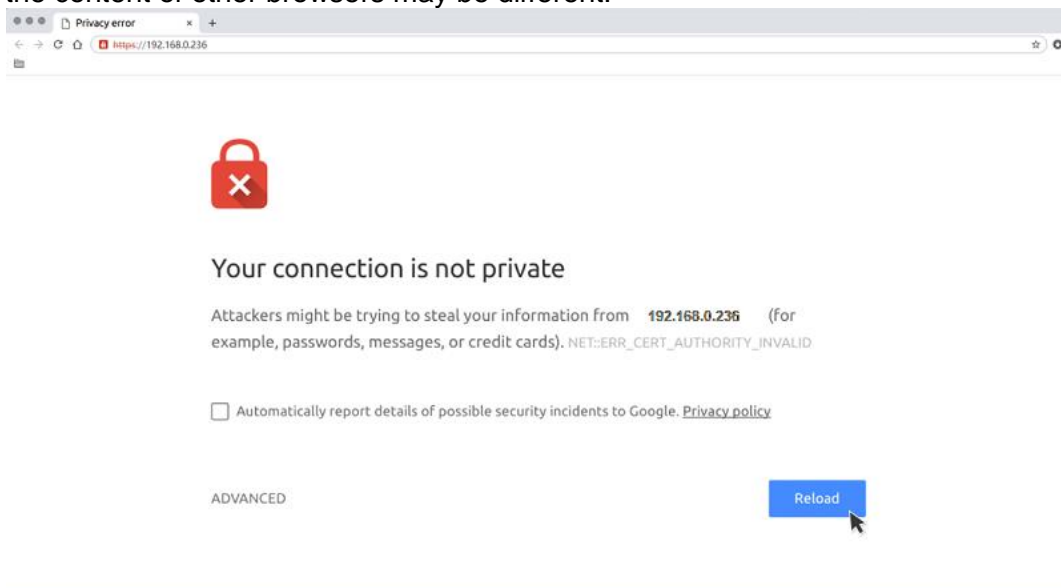

Figure 7-8 Google Chrome privacy settings error page

On this page, click "Advanced" >> "Continue" to access the IPMI management page normally and enter the login page, as shown in Figure 7-9.

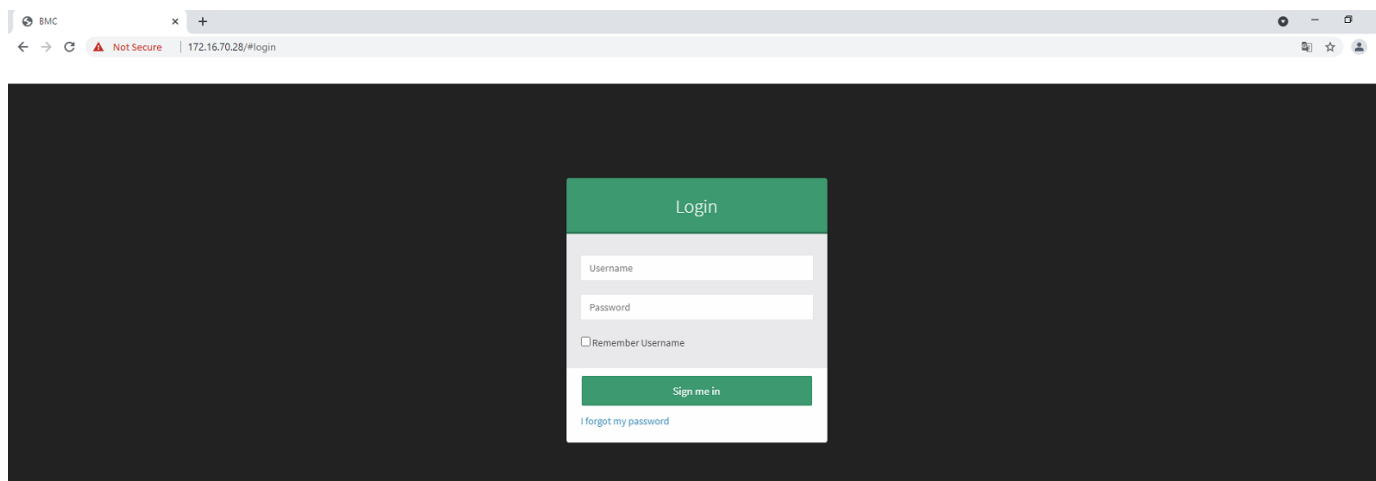

Figure 7-9 IPMI management login interface

7.2.2 Default username and password

Factory default user name: admin
Factory default password: admin

When you log in with this user name, you will have full administrator rights. It is recommended that you change your password after logging in.

7.2.3 IPMI management system content

When you log in to the IPMI management system correctly, you can see the page shown in Figure 7-10.

The screenshot displays the IPMI Management System Home Page dashboard. On the left is a dark sidebar with navigation options: Host Online, Quick Link..., Dashboard, Sensor, System Inventory, FRU Information, Logs & Reports, Settings, Remote Control, Image Redirection, Maintenance, and Sign out. The main content area is titled 'Dashboard Control Panel' and features several widgets:

- 0 d 0 hrs**: HOST Running Time Since Last BMC FW Upgrade.
- 9**: Pending Deassertions.
- 1**: Access Logs.
- Hardware Information**:
 - BMC Firmware Revision: 1.11.1
 - BMC Firmware Build Time: Aug 10 2020 14:45:09 CST
 - BIOS Revision: 105
 - BIOS Name: G3DCL
 - BIOS Firmware Build Time: 08/10/2020 15:56:51
 - CPLD Revision: 09
 - CPLD Name: G3DCL
 - CPLD Build Time: 08/31/2020
- Network Information**:
 - Host System
 - System LAN MAC Address1: fb:f0:82:35:07:52
 - System LAN MAC Address2: fb:f0:82:35:07:53
 - BMC Network Interface
 - Aggregated Network Interface
 - FB:F0:82:35:07:50
 - IPv4 Network Mode
 - DHCP
 - IPv4 Address: 172.16.70.28
 - IPv6 Network Mode
 - DHCP
 - IPv6 Address: fe80::fafb:82ff:fe35:750
- Sensor Monitoring**: All sensors are good now! Currently recovered.

Figure 7-10 IPMI Management System Home Page

IPMI management interface menu description

(1) dash board

On this page, users can view the basic information of the IPMI management system. Including firmware information, network information, and sensor monitoring information.

The firmware information includes BMC firmware version information, BIOS version information, motherboard CPLD version information, backplane CPLD version information, and BMC firmware compilation time information.

The network information includes the MAC address of the system network and BMC network information. You can choose to view the shared network port or dedicated network port of the BMC. BMC network information includes BMC network MAC address information, IPV4 network mode information, IPV4 address information, IPV6 network mode information, and IPV6 address information.

The sensor monitoring information will display the current alarm sensor information in real time, including sensor name, sensor reading, real-time curve change of sensor reading, and alarm status.

(2) sensor

This page displays the status of all sensors. When there is a sensor alarm, the sensor will be displayed in the key sensor column. When the alarm is released, the sensor will be automatically removed from the key sensor column.

(3) System list

This page can view server CPU and memory information. In the block diagram, click the CPU block to view the CPU information. The memory block is displayed in green to indicate that the memory exists. Click the memory block to view the memory information.

(4) Hard Disk Information

For the backplane with Expander, the green square means that the hard disk is in place, otherwise it means it is not in place. You can view the status of the hard disk on the right or below the hard disk block. Left click the green square to view the detailed information of the hard disk, and right click to locate the hard disk.

(5) Power consumption

Under this menu, the power consumption can be capped and the recent power consumption can also be viewed.

(6) FRU information

Select this menu to view the basic information of the FRU.

(7) Log & Report

Under this menu, you can view the IPMI time log, audit log and video log.

(8) Set up

You can configure some BMC under this menu. Including BSOD, date & time, network, etc...

(9) remote control

On this page, you can start KVM, SOL, power control, UID (server indicator light) control.

(10) Mirror redirection

On this page, you can get the latest image file on the remote storage device.

(11) maintain

You can perform basic maintenance operations on the server, such as BMC firmware update, BIOS firmware update

new.

(12) Logout

Click to log out the current user's login.

7.2.4 Introduction to KVM remote management

Start KVM remote management

As shown in Figure 7-11, KVM can be started under the Remote Control> KVM&Java SOL Remote Control menu.

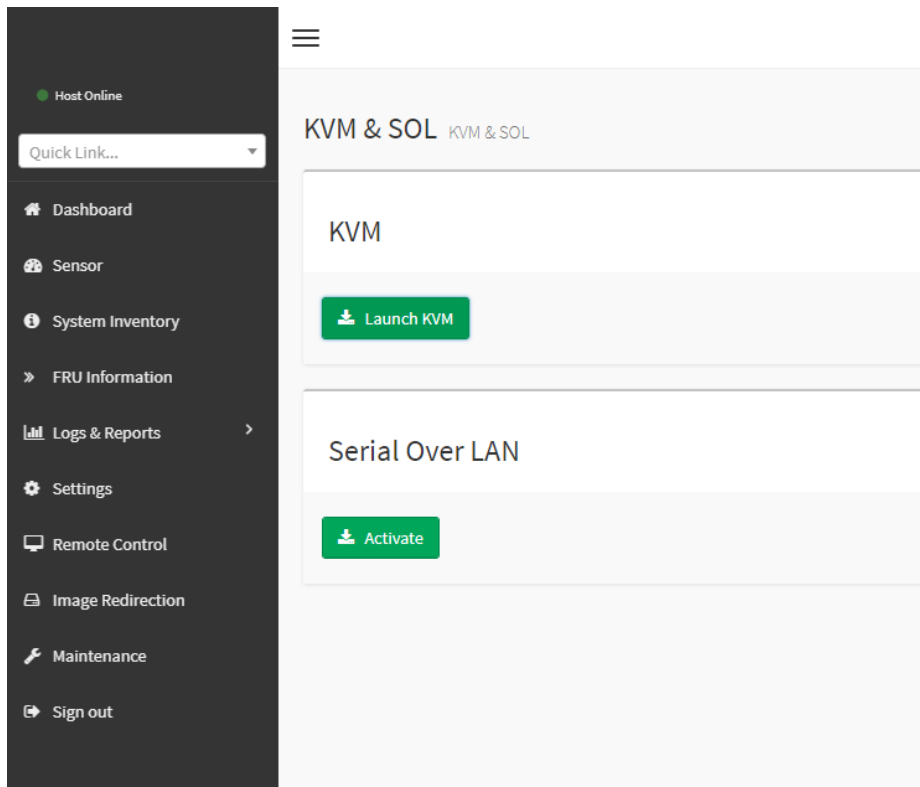

Figure 7-11 Start KVM

7.2.5 KVM page introduction

Figure 7-12 shows the KVM interface after starting KVM.

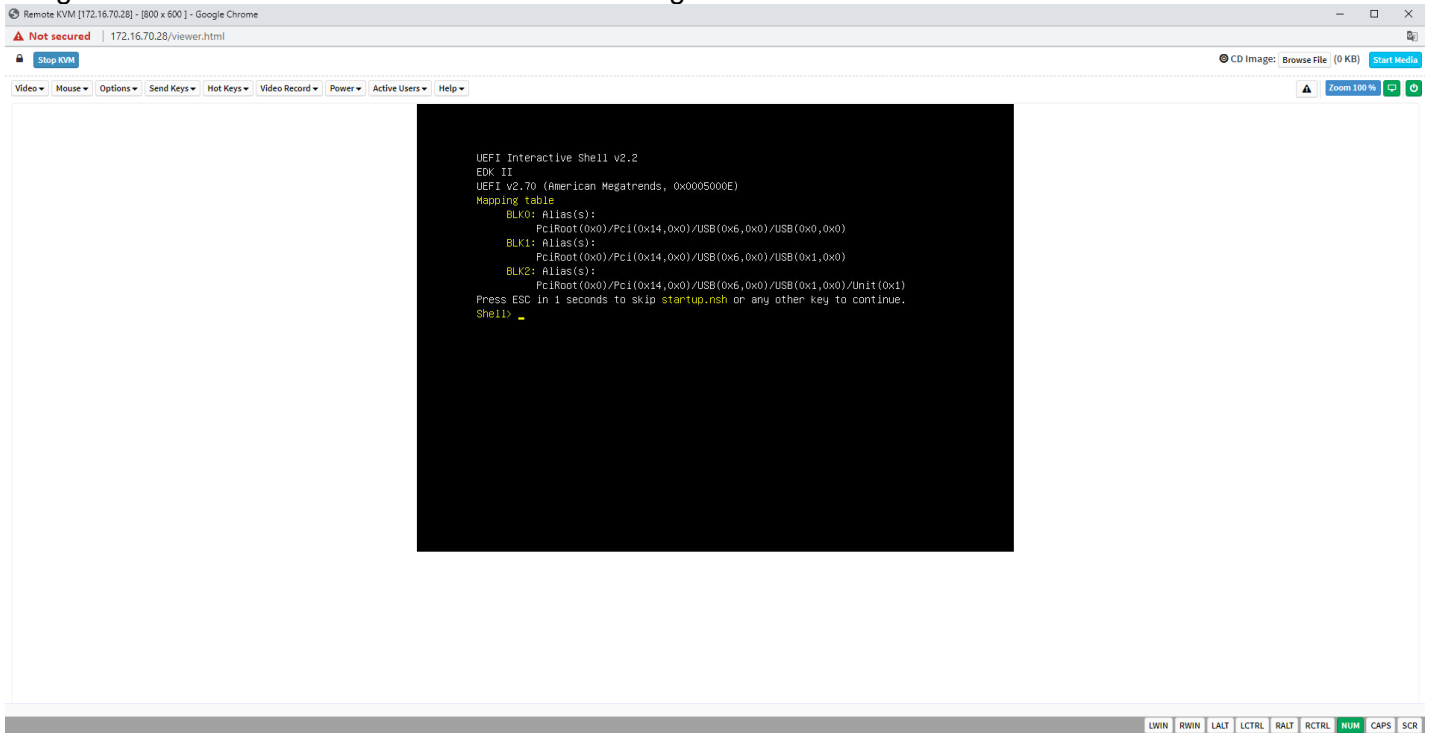

Figure 7-12 KVM interface

As shown in Figure 7-13, the KVM interface includes two parts: one is the menu and shortcut button, the other is the window of remote desktop, that is, the server desktop information returned remotely.

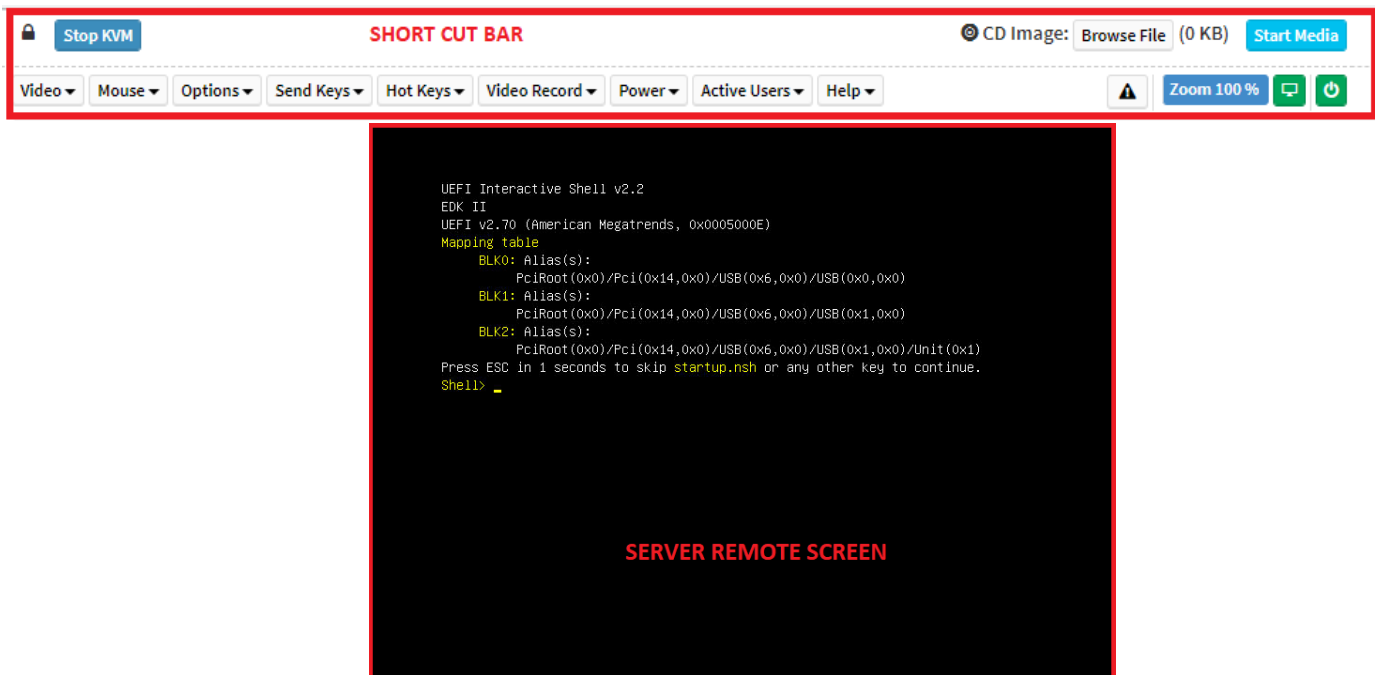

Figure 7-13 KVM interface composition

7.2.6 Remote control quick operation





 Stop KVM	Stop KVM
 CD Image: <input type="button" value="Browse File"/> (0 KB) <input type="button" value="Start Media"/>	Hanging on CD image, usually used for remote installation of operating system
 Zoom 100 %  	The host display is unlocked and the server is switched on and off

Table 1- 29

7.2.7 Introduction to SOL

Click Activate Java SOL on the page shown in Figure 7-14 to open the interface shown in Figure 3-7 below.

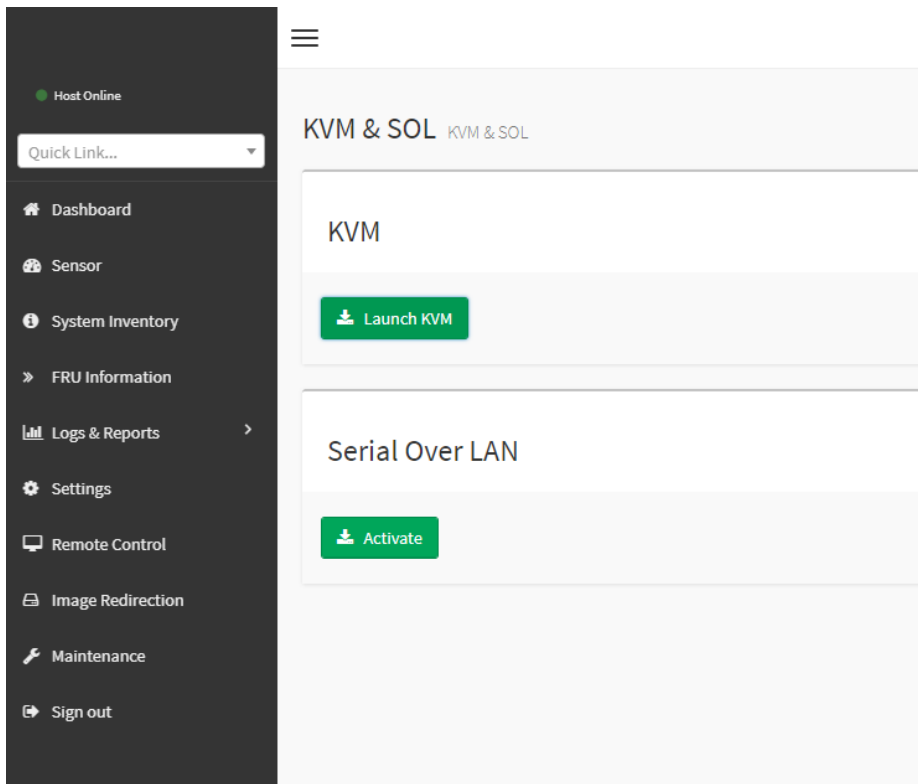

Figure 7-14 Enable Java SOL

1. After clicking Activate, the SOL interface shown in Figure 7-15 will appear.
2. Press Enter to activate the screen.

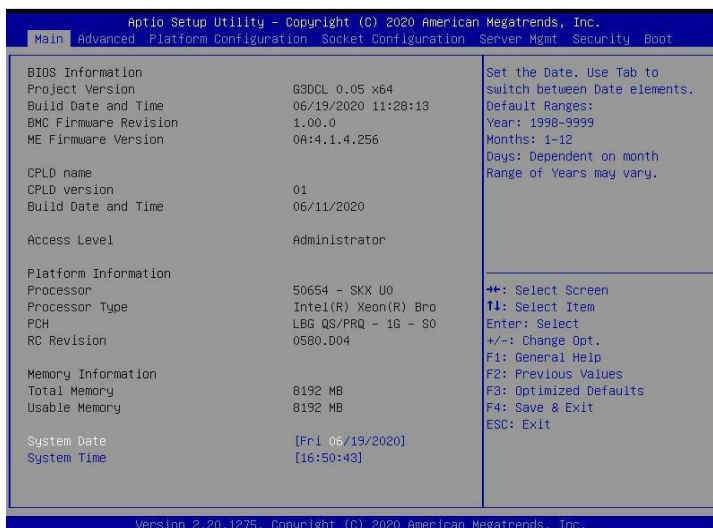

Figure 7-15 SOL operation interface

Note: The SOL interface operation function has only tested the BIOS screen synchronization, and other interfaces have not been tested. This time is an operation demonstration and will not be described in detail.

7.3 Other ways to connect to IPMI

The AST2500 firmware complies with the IPMI 2.0 specification, so users can use the standard IPMI driver assigned by the operating system.

7.3.1 IPMI driver

AST2500 supports the drivers cited by Intel and can be obtained from the following websites: <https://www.intel.com/content/www/us/en/servers/ipmi/ipmi-technical-resources.html> With Windows Server 2003 R2, Microsoft also provides an IPMI driver package, and you can also use the Open IPMI driver in the system.

AST2500 supports the Open IPMI driver of the Linux kernel. Use the following command to load the IPMI driver: `modprobe ipmi_devintf` `modprobe ipmi_si` If you are using an older version of the Linux kernel, you need to replace the "ipmi_si" component with "ipmi_kcs".

7.3.2 IPMI tools and other open source software

AST2500 supports open source IPMI tools, you can also use other software, such as: Open IPMI, IPMI Utility, etc.

The above documents are designed to help you quickly understand and deploy the IPMI functions of the system. Regarding the detailed function operation manual of IPMI, we will provide other help files.

Chapter 8 Product Technical Specifications

8.1 Technical specifications

Features	Technical specifications
Model	2U
Size	2U cabinet type, maximum depth: 748 mm
Processor	Support 1 or 2 Intel Xeon Scalable series processors (up to TDP 165W, optional TDP 205W)
Chipset	Intel C621/C622 series server dedicated chipset
RAM	Support DDR4 ECC RDIMM/LRDIMM server memory, memory frequency support 1866/2133/2400/2666MHz Support 12 DDR4 Channel, each Channel supports 2 DIMMs, a total of 24 DDR4 slots; supports Intel Optane 2933MHz memory
Storage controller	Internal storage controller: PCH supports RAID 0\1\10&5 External HBA (non-RAID): 12 Gbps SAS HBA Internal storage: 2 PCIe 3.0 x4 M.2 slot, 2 Mini SSD slots (SATA DOM)
Driver	Support 8/12/25 hot-plug SAS/SATA(HDD/SSD)
Power supply	Platinum level 500W, 800W, 1200W, 1600W hot-swappable redundant power supply, optional support 240V and 336V high voltage DC power supply, -48V high voltage DC power supply
External port&PCIE	Front port: VGA, 2 USB3.0 Rear: VGA, 2 USB3.0, 1 management network port, 2 RJ45 network ports PCIE expansion board: up to 10 PCIE expansion slots OCP slot: 1 OCP 3.0 (X8)
System fan	Standard 4 8038 N+1 hot-swappable redundant fans, optional 4 8056 N+1 hot-swappable redundant fans
Network	Onboard 2 1GbE or 10GbE (RJ45) TPM/TCM (optional)
Security	Chassis opening intrusion detection Lock the upper cover of the chassis
Management	The onboard iBMC management module supports management features such as IPMI, SOL, KVM Over IP, and virtual media
Operating system	Microsoft Windows Server , Red Hat Enterprise Linux , SUSE Linux Enterprise Server , CentOS , Ubuntu
Virtualization support	Citrix Xen Server , Vmware ESXi , Linux KVM , Windows Hyper-V
Temperature	Standard operating temperature: 10°C-40°C (without direct sunlight) Extended operating temperature: 5°C-40°C (limited configuration meets) Transportation storage temperature: 10°C-40°C
Humidity	Working humidity: 30%-80% (non-condensing) Storage humidity: 5%-95% (non-condensing)

Table 1- 29