



SNR-RS-G4 1U

User Manual

Foreword

This manual is the product technical manual for the SNR platform 1U model servers. It primarily provides an introduction and explanation of the product's appearance, structure, hardware installation, and basic configuration.

Please note that this manual is intended for reference and research purposes for professional technical personnel. The installation and maintenance of this product should only be performed by experienced technical personnel.

Contents

Foreword.....	Ошибка! Закладка не определена.
1. Product Introduction	5
1.1 Product Overview	5
1.2 Product Structure	6
1.3 Logical Structure	7
1.4 Product Specifications	8
2. Hardware Description	10
2.1 Front Panel	10
2.1.1 Appearance	10
2.1.2 Indicator lights and buttons	10
2.2 Rear Panel	12
2.2.1 Appearance	12
2.2.2 Indicator lights and buttons	12
2.2.3 Interface	13
2.3 Processor	14
2.4 Memory	14
2.4.1 Memory slot location	14
2.4.2 Memory installation guidelines	15
2.5 Storage	16
2.5.1 Hard drive configuration	16
2.5.2 Hard drive serial number	16
2.5.3 Hard drive status indicator	16
2.6 Power Supply	17
2.7 Fans	17
2.8 I/O Expansion	18
2.8.1 PCIe slot location	18
2.8.2 PCIe slot description	18
2.8.3 PCIe Expansion Module	19
x16 to x16 adapter card	19
2 pcs x8 to 2 pcs x8 adapter cards	19
2.9 PCBA	20
2.9.1 Motherboard	20
2.9.2 Hard drive backplane	22
3. Installation Instructions	23
3.1 Chassis Top Cover Installation	23
3.2 Installation of Accessories	23
3.2.1 CPU installation	23

3.2.2 Heatsink installation	24
3.2.3 Memory installation	25
3.2.4 Server slide rail installation	26
4. Configuration Instructions	29
4.1 Initial Configuration	29
4.1.1 Power on and start	29
4.1.2 Initial data	31
4.1.3 Configure BIOS	31
4.1.4 Configure BMC	32
5. Appendix	38
Front Panel Indicator Lights Alarm	38
IPMI Connection Failure	39

1. Product Introduction

1.1 Product Overview

SNR-SR-G4 1U Series 1U Dual-socket Rack-Mount Server is a new generation of versatile 1U dual-socket rack-mount servers launched by SNR to meet the needs of the Internet, IDC (Internet Data Center), cloud computing, enterprise markets, and telecom business applications. It is suitable for core IT operations, cloud computing virtualization, high-performance computing, distributed storage, large-scale data processing, enterprise or telecom business applications, and other complex workloads. This server features low power consumption, strong expandability, high reliability, easy management, and deployment. Its main configurations include:

- Up to 2 4th/5th generation Intel® Xeon® Scalable processors.
- Up to 32 DIMM DDR5 memory slots.
- Up to 8 hot-swappable 2.5-inch SAS/SATA/U.2 drives and 2 hot-swappable 2.5-inch U.2 drives.
- 1 PCIe full-height slot, 2 PCIe half-height slots, 2 OCP3.0 slots.

The physical image of the server is shown below:



Front view 1-1



Rear view 1-2

1.2 Product Structure

SNR-SR-G4 1 U Eagle Stream 1U Dual-Socket Rack-Mount Server Exploded View

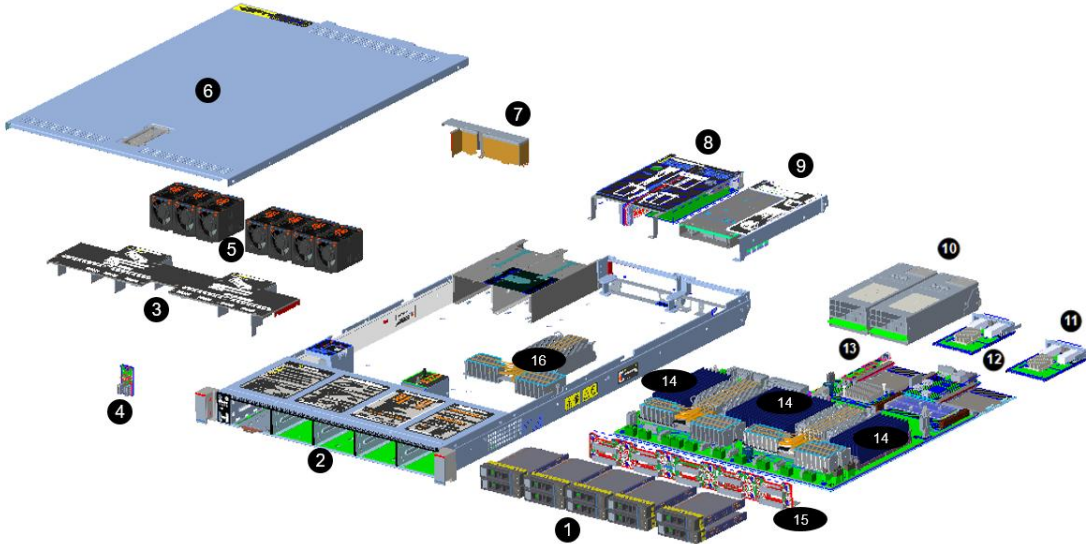

Structure diagram 1-3

Table 1-1

No.	Name	No.	Name
1	Hard Drive	9	Full-Height PCIe Expansion Module
2	Hard Drive Bracket Module	10	Power Module
3	Air Guide Module	11	OCP 3.0
4	LED Board	12	BMC Card
5	Fan Module	13	UID Board
6	Rear Top Cover	14	Memory Slot
7	Power Air Duct	15	Backplane
8	Dual Half-Height PCIe Expansion Module	16	T-Shaped Heatsink

1.3 Logical Structure

The logic of the SNR-SR-G4 1 U Series Dual-Socket Rack-Mount Server is as shown in the following diagram:

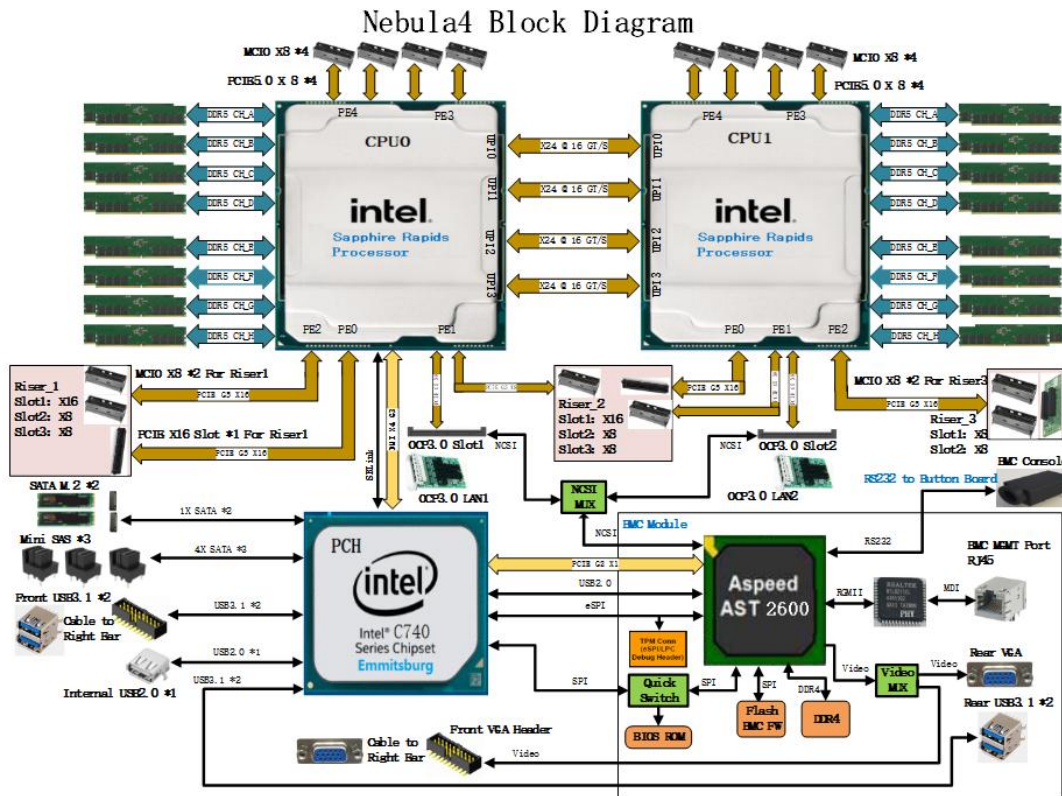

Motherboard logic block diagram 1-4

- The CPU adopts the 4th/5th generation Intel Xeon Scalable processor, LGA4677 socket.
- Each CPU supports 8 channels, and each channel supports 2 DDR5 RDIMM/LRDIMM memories.
- Onboard 2 M.2 slots (supports 22110/2280 specifications), only supports SATA signals.
- PCH uses INTEL C740 series chipset.
- The BMC chip uses ASPEED's AST2600 control chip for IPMI remote management. VGA output port, dedicated Gigabit RJ45 management network port, and connection to PCH through RMI/NCSI.

1.4 Product Specifications

Product Series	SNR-SR-G4 1U
Form Factor	1U
System Size	799x433.4x43.6mm (depth*width*height)
Processor	Supports 1 or 2 4th/5th generation Intel® Xeon® Scalable processors
Memory	32 DDR5 memory slots, supporting DDR5 RDIMM 4400/4800 MHz
Internal Storage Interface	3 MiniSAS HD interfaces, 2 SATA M.2 interfaces (22110/2280 specifications)
External Hard Drive	Up to 8 hot-swappable 2.5-inch SAS/SATA/U.2 hard drives and 2 hot-swappable 2.5-inch U.2 hard drives
External Ports	Front: 2 USB 3.0
	Rear: 1 VGA, 1 COM port, 2 USB 3.0, 1 RJ45 Gigabit Management port
PCIE Expansion Form	1 Full-Height PCIe slots, 2 Half-Height PCIe slots, 2 OCP 3.0 slots.
PCIE Expansion Specifications	Riser 1: 1 Full-Height PCIe 5.0 x16 Riser 2: 2 Half-Height PCIe 5.0 x8(in PCIe x16 slot) OCP: 2*OCP 3.0(Pcie 5.0 x8)
Power Supply	Supports AC 220V 800W, 1300W, 1600W, 2000W, and 2200W Redundant Power Supply (Adaptable to Actual Power Requirements).
Fan	Standard 7*4056 hot-swappable N+1 redundant fans
Security	Supports TPM module
IPMI	IPMI 2.0
Management Port	1 dedicated RJ45 management port

RoHS	Compliant with RoHS2.0
Working Temperature & Humidity	Temperature 5°C~35°C/humidity 20%~80% RH non-condensing
Storage Temperature & Humidity	Short-term storage (≤ 72 hours): Temperature $-40^{\circ}\text{C} \sim 70^{\circ}\text{C}$ / Humidity 20% $\sim 90\%$ RH (non-condensing, including packaging) Long-term storage (> 72 hours): Temperature $20^{\circ}\text{C} \sim 28^{\circ}\text{C}$ / Humidity 30% $\sim 70\%$ RH (non-condensing, including packaging)

Table 1-2

2. Hardware Description

2.1 Front Panel

2.1.1 Appearance

- 10x2.5-inch hard drive configuration

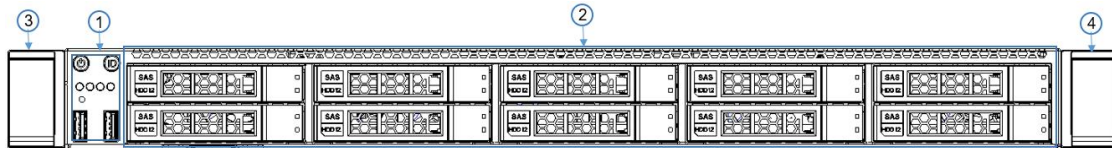

Figure 2-1

No.	Name	No.	Name
1	Switch Panel	3	Left mounting ear
2	2.5-inch hard drive	4	Right mounting ear

Table 2-1

2.1.2 Indicator lights and buttons

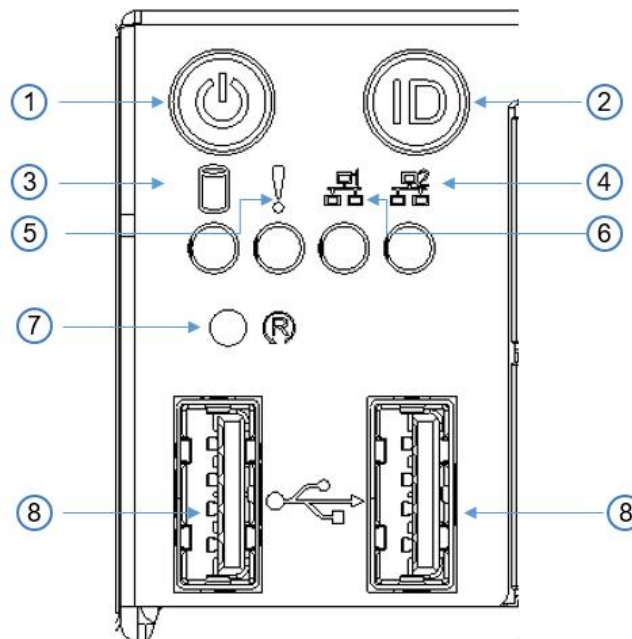







Figure 2-2

No.	Indicator/Button	No.	Indicator/Button
1	Power switch button/indicator	5	System alarm indicator
2	UID button/indicator	6	OCP1 network card presence

			indicator
3	Hard drive activity indicator	7	Reset server button
4	OCP2 network card presence indicator	8	USB 3.1 port
LED status description			
Logo	Indicator light/button	Status description	
	Power Indicator	<p>Description of the power indicator light:</p> <p>Green (steady on): Indicates that the device has been powered on normally.</p> <p>Green (blinking): Indicates that the device is in standby.</p> <p>Green off: Indicates that the device is not powered on.</p> <p>Power button description:</p> <p>Press the button shortly in the power-on state, and the OS will shut down normally.</p> <p>Press and hold the button for 6 seconds in the power-on state to force the server to power off.</p> <p>Press the button shortly in the power-on state to start the machine.</p>	
	UID button/indicator	<p>The UID button/indicator is used to conveniently locate the server to be operated, and the indicator can be turned off or on by manually pressing the UID button or remotely controlling the BMC command.</p> <p>Description of UID indicator light:</p> <p>Blue (steady on/blinking): Indicates that the server is located.</p> <p>Off: Indicates that the server is not located.</p> <p>UID button description: Short press this button to turn on/off the positioning light.</p>	
	Reset server button	Press to restart the server	
	Hard drive indicator	If there is data read or write activity on the PCH, the hard drive indicator will blink.	
	System Alarm Indicator	System warning indicator. Including system alarms, fan alarms, power supply alarms, etc., which can be viewed through the IPMI management software	
	OCP1 network card presence status indicator light	<p>Corresponding to the OCP1 network card connection status indicator light.</p> <p>Green (steady on): Indicates that the OCP1 network card is in place.</p> <p>Off: Indicates that the OCP network card is not</p>	

		installed or is malfunctioning. Note: This corresponds to the two OCP network cards on the motherboard.
	OCP2 network card presence status indicator light	Corresponding to the OCP2 network card connection status indicator light. Green (steady on): Indicates that the OCP2 network card is in place. Off: Indicates that the OCP network card is not installed or is malfunctioning. Note: This corresponds to the two OCP network cards on the motherboard.
USB Port	USB 3.1	Used for connecting USB devices

Table 2-2

2.2 Rear Panel

2.2.1 Appearance

- Appearance of the rear panel

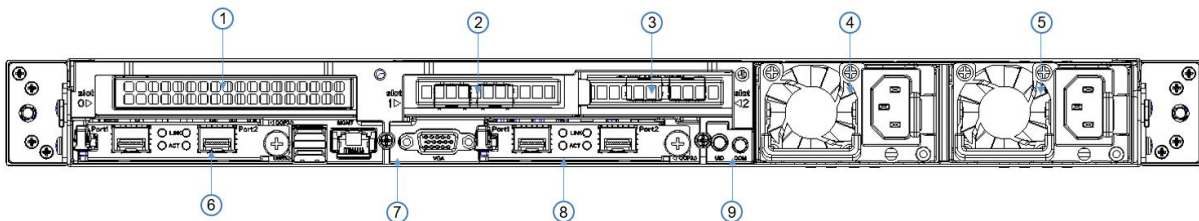

Figure 2-3

No.	Name	No.	Name
1	Riser 1 module	2	Riser 2 module
3	Riser 3 module	4	Power module 1
5	Power module 2	6	OCP1 network card slot
7	BMC Management Module	8	OCP2 network card slot
9	UID		

Table 2-3

2.2.2 Indicator lights and buttons

- Rear Panel Indicators

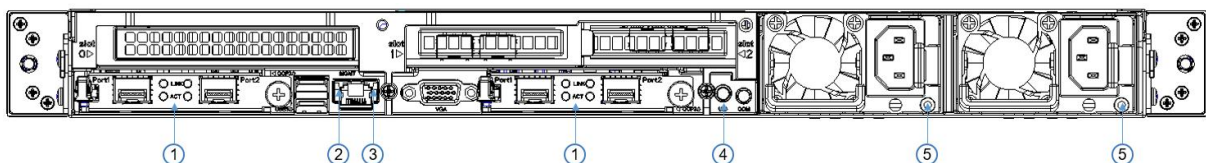

Figure 2-4

No.	Name	No.	Name
1	OCP Network Card Indicator Light	2	Management network port connection status indicator light
3	Management network port data transmission status indicator light	4	UID button
5	Power module indicator light	-	-

Table 2-4

- Description of Power Module Indicators

Indicator light/button	Status description
Power module indicator	<p>Green (steady on): Indicates that the input and output are normal.</p> <p>Orange (steady on): Indicates that the AC power cord is unplugged or the power module is missing, and only one parallel-connected power module has AC input; the power module failure causes the output to be turned off, such as OVP, OCP, fan failure, etc.</p> <p>Green (1Hz/blinking): Indicates that the input is normal, the voltage is too low (less than 12V) or the power supply is in the intelligent standby mode.</p> <p>Green (2Hz/blinking): Indicates the firmware is undergoing online upgrade.</p> <p>Orange (1Hz/blinking): Indicates continuous power warning events during power operation, such as high temperature, high power, or large current.</p> <p>Off: Indicates no AC power input.</p>

Table 2-5

2.2.3 Interface

- rear panel interface

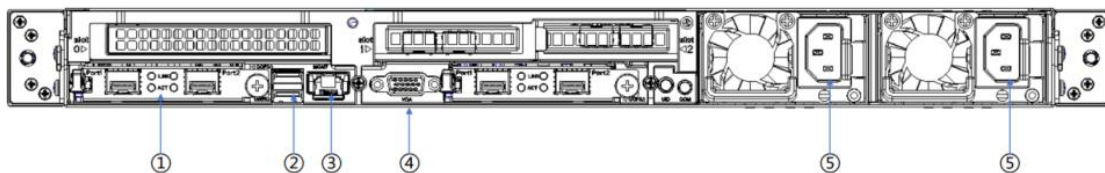

Figure 2-5

No.	Name	No.	Name
1	OCP Network Card Port	2	USB3.1 interface
3	Management network port	4	VGA
5	Power module power supply		

	interface		
--	-----------	--	--

Table 2-6

2.3 Processor

- Supports 1 or 2 Intel 4th/5th generation Xeon Scalable processors.
- When configuring with 1 processor, it should be installed in CPU 0 position.
- Processors installed in the same server must have the same model.
- For specific optional system configurations, please consult SNR sales.
- Processor positions are as shown in the following diagram:

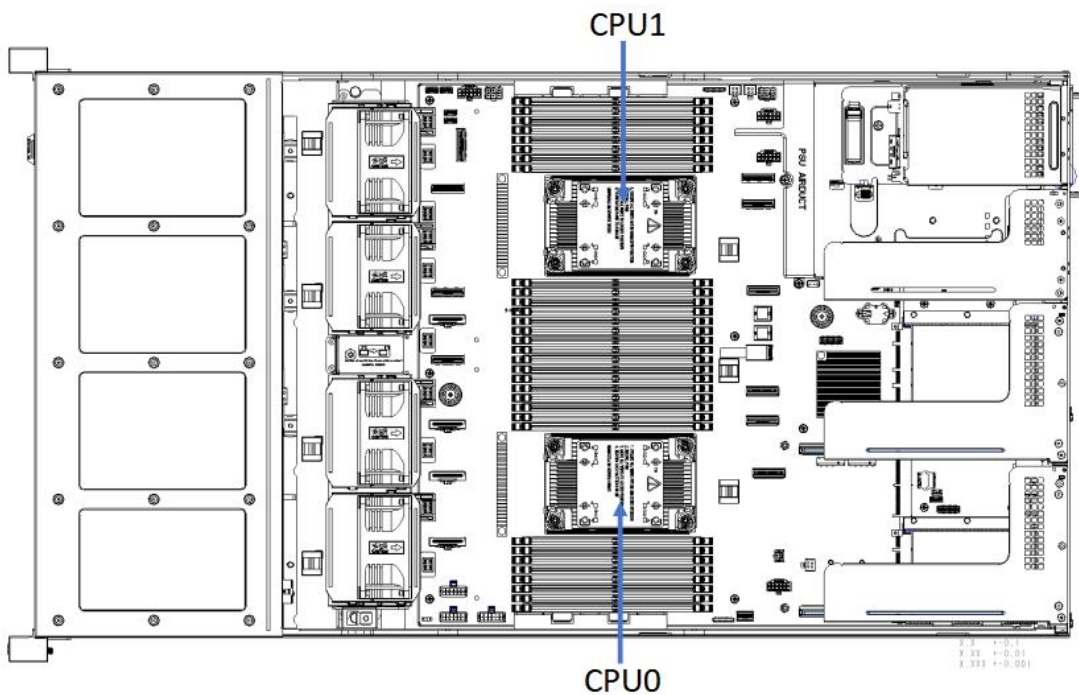

Figure 2-6

2.4 Memory

2.4.1 Memory slot location

This motherboard adopts the Intel Eagle Stream platform. Each CPU supports 8 channels, and each channel supports 2 DDR5 memories. The motherboard can support 32 DIMM DDR5 memories. When inserting only

one memory, prioritize A0, B0, C0, D0, E0, F0, G0, H0 (memory slots with blue plastic color). It supports DDR5 ECC RDIMM/RDIMM-3DS server memory. The positions are as shown in the following diagram:

- memory slot location

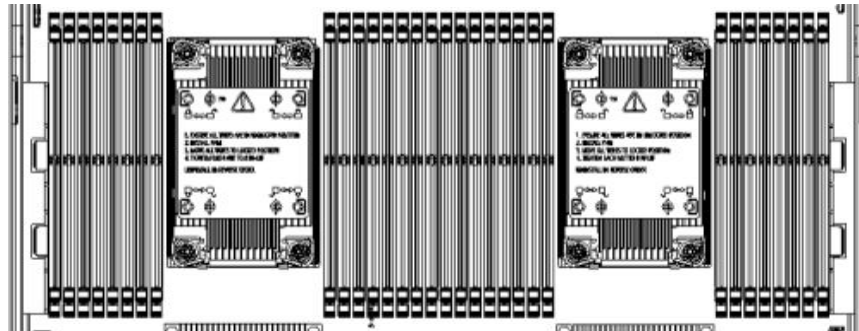

Figure 2-7

2.4.2 Memory installation guidelines

The server can install up to 32 DDR5 memories and supports DDR5 RDIMM server memory. The memory frequency supports 4400/4800MHz. The memory installation principles must be followed when configuring the

	Chan 1 (7/H)		Chan 0 (6/G)		Chan 1 (5/F)		Chan 0 (4/E)		Chan 0 (0/A)		Chan 1 (1/B)		Chan 0 (2/C)		Chan 1 (3/D)	
	Slot0	Slot1	Slot0	Slot1	Slot0	Slot1	Slot0	Slot1	Slot1	Slot0	Slot1	Slot0	Slot1	Slot1	Slot0	
DDR5																
1+0								DDR5		DDR5						
2+0				DDR5				DDR5		DDR5						
4+0				DDR5				DDR5		DDR5						
6+0				DDR5				DDR5		DDR5						
	DDR5			DDR5				DDR5		DDR5						
	DDR5			DDR5				DDR5		DDR5						
8+0	DDR5			DDR5				DDR5		DDR5						
12+0	DDR5			DDR5	DDR5	DDR5		DDR5	DDR5	DDR5			DDR5	DDR5	DDR5	
	DDR5	DDR5	DDR5		DDR5	DDR5	DDR5			DDR5	DDR5	DDR5		DDR5	DDR5	DDR5
16+0	DDR5	DDR5	DDR5	DDR5	DDR5	DDR5	DDR5	DDR5	DDR5	DDR5	DDR5	DDR5	DDR5	DDR5	DDR5	DDR5

memory (CPU1 is the same as CPU0).

Figure 2-8

Note:

1. All configured memory must be of DDR5 RDIMM type.

2. For SPR CPUs, at least one DDR5 memory module must be configured.
3. Different types (RDIMM, RDIMM-3DS) and specifications (capacity, frequency, bit width, rank, height, etc.) of DDR5 memory are not compatible for mixed usage.
4. Different models of Intel Xeon Scalable processors support varying maximum memory capacities.

2.5 Storage

2.5.1 Hard drive configuration

Configuration	Front Hard Drive	Rear Hard Drive
10-Bay Configuration	Front 2.5-inch Hard Drives - Slots 0 to 7 support NVMe/SAS/SATA hard drives - Slots 8 and 9 support U.2 NVMe hard drives	N/A

Table 2-7

2.5.2 Hard drive serial number

- 10x2.5-inch hard drive configuration

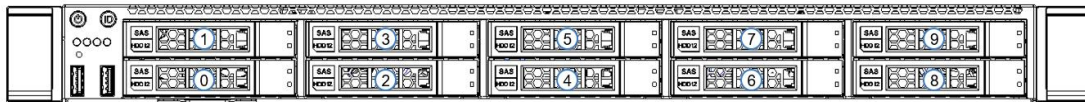

Figure 2-9

2.5.3 Hard drive status indicator

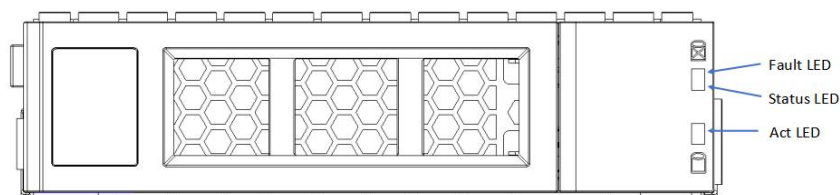

Figure 2-10

- Hard drive status indicator description

Function	Act LED	Status LED	Fault LED
Hard drive in place	Steady on	OFF	OFF
Hard drive	Blinking at	OFF	OFF

activity	4Hz/second		
Hard drive positioning	Steady on	Blinking 4Hz/second	OFF
Hard drive error	Steady on	OFF	Steady on
RAID rebuild	Steady on	OFF	Blinking 1Hz/second

Table

2-8

2.6 Power Supply

- Supports 1 or 2 power modules;
- Supports hot-swapping;
- When configured with 2 power modules, supports 1+1 redundancy;
- For power modules configured in the same server, the power module models must be identical;
- For specific optional system accessories, please consult SNR sales.
- The power supply positions are as shown in the following diagram:

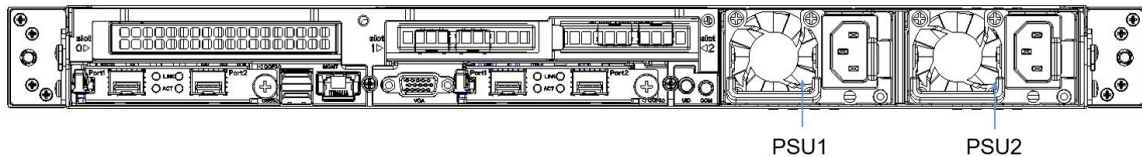

Figure 2-11

2.7 Fans

- Supports 7 fan modules;
- Supports hot-swapping;
- Supports single fan failure;
- Supports variable fan speed;
- For fan modules configured in the same server, the fan module models must be identical.
- The fan positions are as shown in the following diagram:

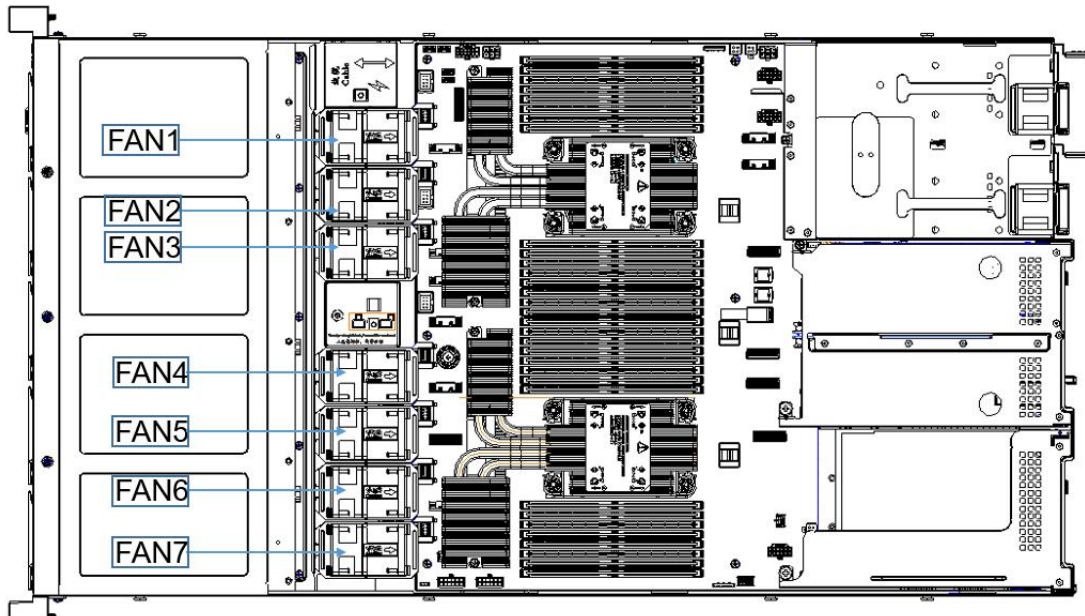

Figure 2-12

2.8 I/O Expansion

2.8.1 PCIe slot location

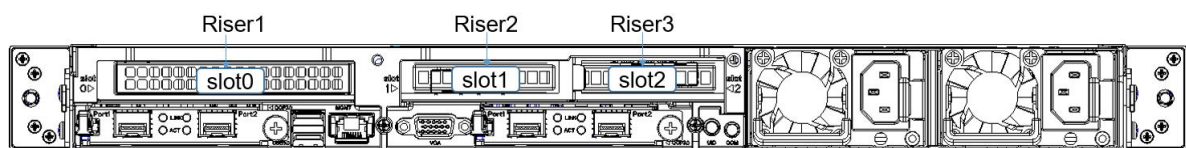

Figure 2-13

- The slot provided by the Riser1 module is Slot0, using a one-slot PCIe full-height half-length expansion module.
- The slot provided by the Riser2 module is Slot1, using a one-slot PCIe half-height half-length expansion module.
- The slot provided by the Riser3 module is Slot2, using a one-slot PCIe half-height half-length expansion module.

2.8.2 PCIe slot description

When CPU1 is not in place, its corresponding PCIe slot is unavailable.

PCIe slot	Subordinate CPU	PCIe standard	Bus bandwidth	Slot size
OCP1	CPU0	PCIe 5.0	X8	

OCP2	CPU1	PCIe 5.0	X8	
Slot 0	CPU0	PCIe 5.0	X16	Full-Height Half-Length
Slot 1	CPU1	PCIe 5.0	X8	Half-Height Half-Length
Slot 2	CPU1	PCIe 5.0	X8	Half-Height Half-Length

Note:

- ◆ PCIe slots with a bus bandwidth of PCIe x16 are backward compatible with PCIe x8, PCIe x4, and PCIe x1 cards. However, they are not upward compatible, meaning that the bandwidth of the PCIe slot cannot be smaller than the bandwidth of the inserted PCIe card.
- ◆ The slot size of a full-height full-length PCIe slot is backward compatible with full-height half-length and half-height half-length PCIe cards. The slot size of a full-height half-length PCIe slot is backward compatible with half-height half-length PCIe cards.
- ◆ The power capacity of all slots can support PCIe cards with a maximum power of 75W. The power consumption of the PCIe card depends on the model of the card.

Table 2-9

2.8.3 PCIe Expansion Module

- PCIe Expansion Module 1
 - x16 to x16 adapter card
 - Installed in Riser1 position, providing PCIe slots as Slot0

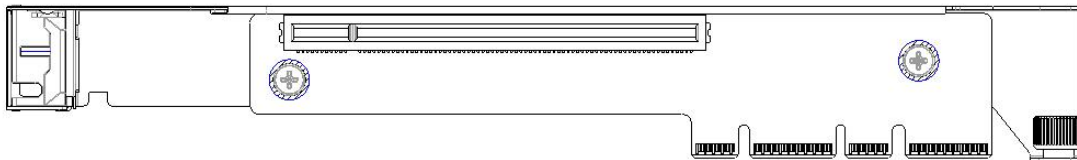

Figure 2-14

- Dual PCIe Expansion Module 2
 - 2 pcs x8 to 2 pcs x8 adapter cards
 - Installed in the Riser2 position, providing PCIe slot as Slot1
 - Installed in the Riser3 position, providing PCIe slot as Slot2

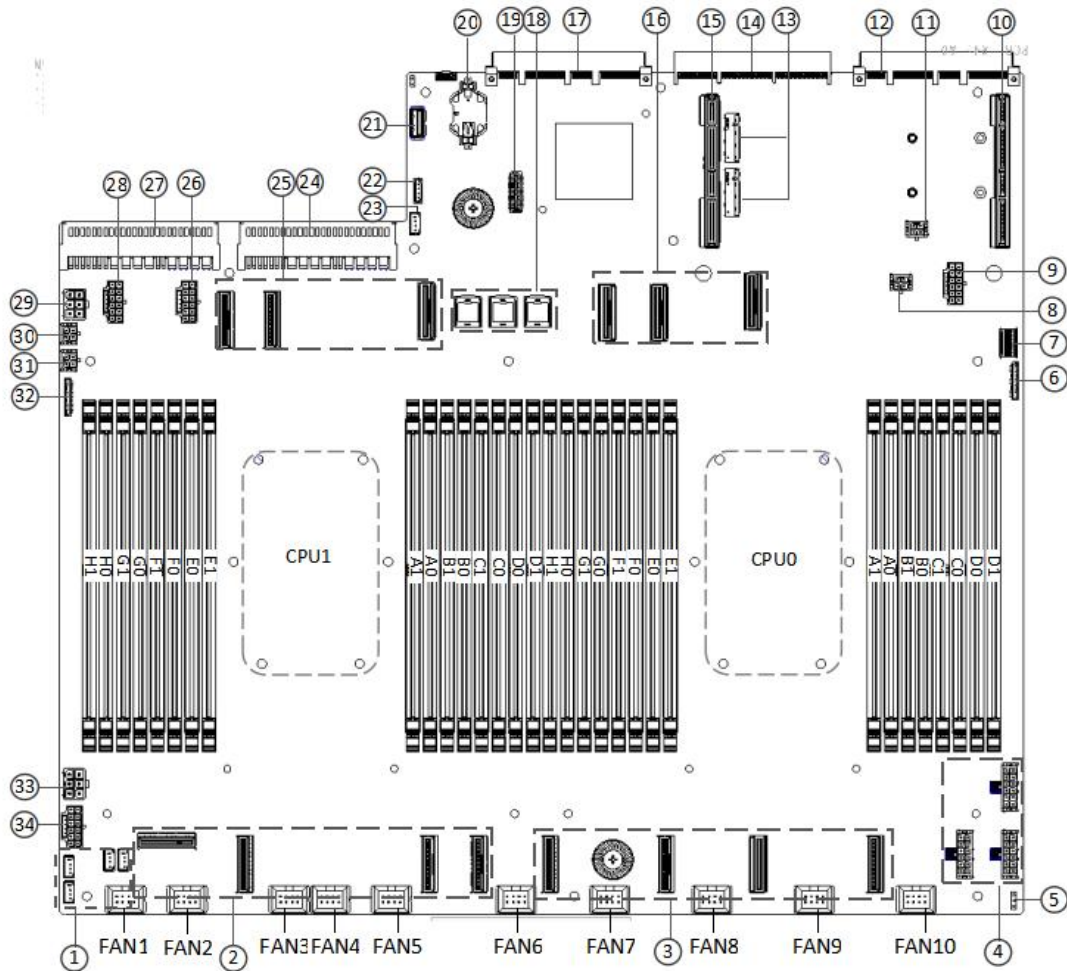



Figure 2-15

2.9 PCBA

2.9.1 Motherboard



Motherboard Figure 2-16

No.	Name	No.	Name
CPU0	CPU0 DDR5 Memory Channels	CPU0	CPU0 DDR5 Memory Channels
DIMMA1/A0/B1/B0/C1/C0/D1/D0	1,2,3,4 connectors	DIMMH0/H1/G0/G1/F0/F1/E0/E1	8,7,6,5 connectors
CPU0	CPU0 DDR5 Memory Channels	CPU1	CPU1 DDR5 Memory Channels
DIMMA1/A0/B1/B0/C1/C0/D1/D0	9,10,11,12 connectors		

DIMMA1/A0/B1/B0/C1/C0/D1/D0		1,2,3,4 connectors	
CPU1 DIMMH0/H1/G0/G1/F0/F1/E0/E1		CPU1 DDR5 Memory Channels 8,7,6,5 connectors	
1	2 hard drive backplane I2C connectors, 2 MCIO I2C connectors	2	MCIO x8 connectors(CPU1) × 4
3	MCIO x8 connectors(CPU0) × 4	4	Three 2*6Pin hard drive backplane power connectors
5	Chassis intrusion connector	6	Right Front Panel VGA connectors
7	Right Front Panel USB3.0 connectors	8	NIC AUX power connector
9	2*6+4Pin high power GPU connector	10	CPU0 PCIE5.0 Port0 X16 GENZ168 connectors
11	Rear window hard drive (2 disks) backplane power connector	12	CPU0 OCP3.0connectors
13	SATA M.2 connectors	14	BMC Module Board-to-Board Connector
15	CPU1 PCIE5.0 Port0 X16 GENZ168 connectors	16	MCIO x8 connectors(CPU0) × 3
17	CPU1 OCP3.0 connectors	18	SATA connectors
19	BMC Module Cable Connector	20	Button Cell Battery
21	USB Interface	22	RAID KEY connectors
23	Hard Drive Backplane I2C Connector	24	3000W Power Supply High-power Connector
25	MCIO x8 Connector (CPU1) × 3	26	2*6+4Pin High-power GPU Connector
27	3000W Power Supply High-power Connector	28	2*6+4Pin High-power GPU Connector
29	Rear Window RISER-PCIE5.0 Backplane Power Connector	30	Rear Window Hard Drive (2 drives) Backplane Power Connector
31	Rear Window Hard Drive (2 drives) Backplane Power Connector	32	Left Front panel connectors
33	Rear Window Hard Drive (2 drives) Backplane Power Connector	34	2*6+4Pin High-power GPU Connector

Table 2-10

2.9.2 Hard drive backplane

- 10×2.5-inch Backplane

TOP surface

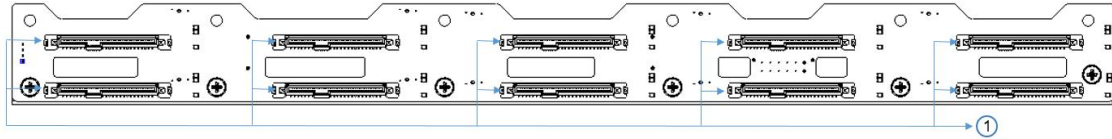

Figure 2-17

No.	Description	Function
1	SFF-8639 U.2 hard drive connector	Supports PCIe×4 and SAS/SATA U.2 interface, used to connect HDD/SSD/NVME

Table 2-11

Bottom surface

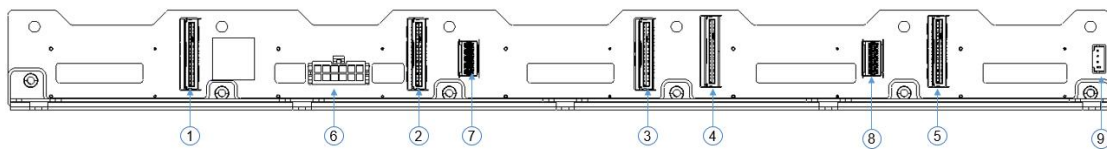

Figure 2-18

No.	Description	Function
1、2、3、4、5	MCIO connector	provides PCIe x8 interface for connecting CPU and NVMe SSD
6	Power connector	backplane power transmission connector for 12V and 5V power transmission
7、8	SFF-8654 Slimline connector	provides SAS/SATA x4 interface for connecting PCH or HBA/RAID Card
9	IIC connector	for connecting the IIC interface on the motherboard to achieve communication with the BMC

Table 2-12

3. Installation Instructions

3.1 Chassis Top Cover Installation

- Step 1: Lift the slot at the opening position, push and lift it in the direction indicated by the diagram.

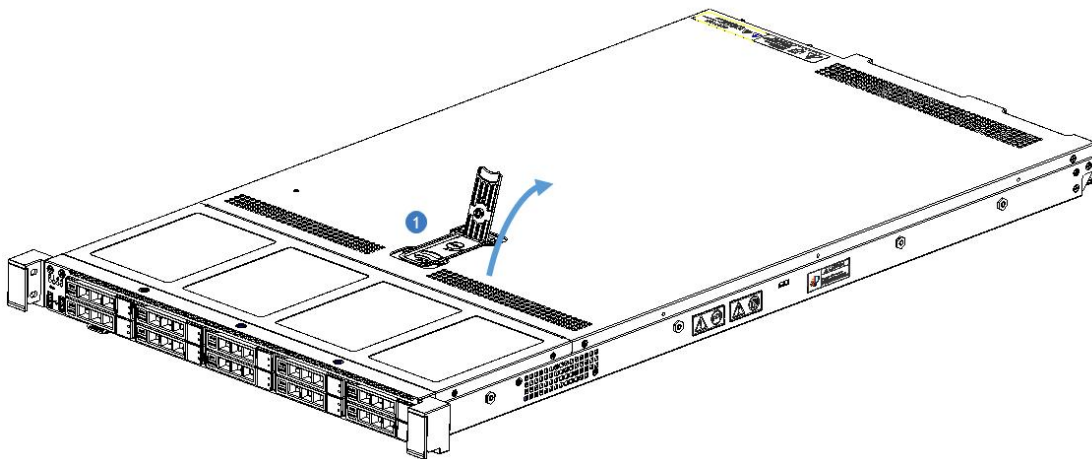

Figure 3-1

3.2 Installation of Accessories

3.2.1 CPU installation

- Step 1: Align the triangular mark on the CPU with the handle on the bracket as shown in the diagram, and mount the CPU onto the heatsink.

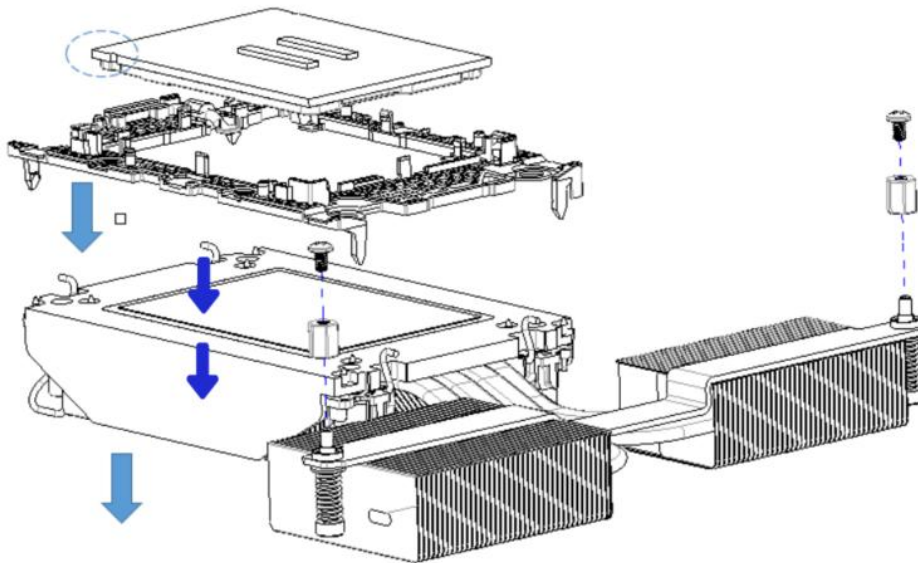

Figure 3-2

3.2.2 Heatsink installation

- Step 1: Remove the protective cover on the motherboard CPU socket.
- Step 2: Install the CPU and heatsink onto the CPU socket. (As shown in the diagram below)

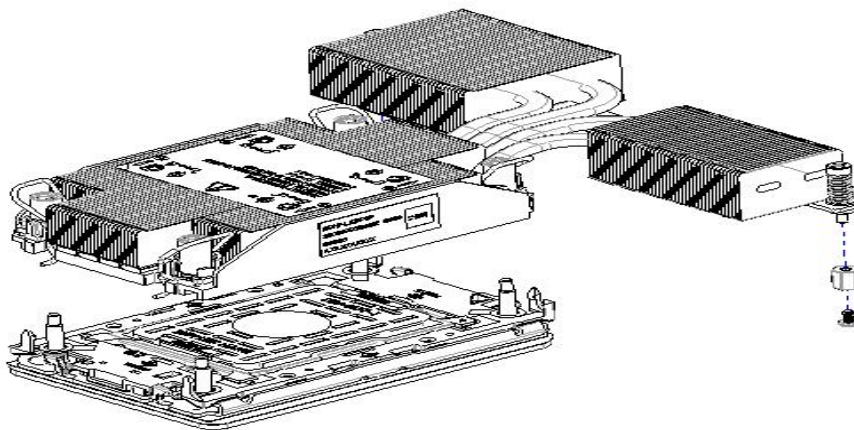

Figure 3-3

- Step 3: Press down on the four corners of the heatsink's fixing lock towards the outside, and, following the diagram below, rotate the screws fixing the heatsink in a clockwise direction twice to secure the heatsink to the motherboard.

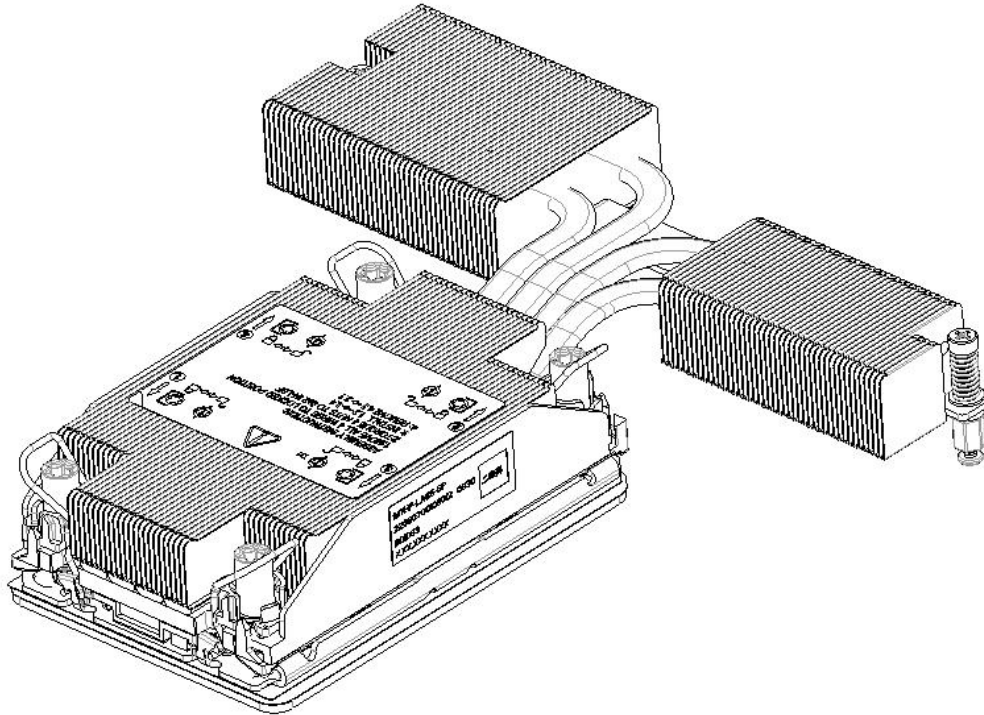



Figure 3-4

 **Caution:** The pins on the motherboard are extremely fragile and can be easily damaged. To prevent damage to the motherboard, do not touch the processor or the contact points on the processor socket.

3.2.3 Memory installation

The 16 memory slots controlled by CPU0 on the motherboard are as follows: CPU0 DIMMB0/B1, DIMMA0/A1, DIMMD0/D1, DIMMC0/C1, DIMMG1/G0, DIMMH1/H0, DIMME1/E0, DIMMF1/F0. The 16 memory slots controlled by CPU1 are as follows: CPU1 DIMMB0/B1, DIMMA0/A1, DIMMD0/D1, DIMMC0/C1, DIMMG1/G0, DIMMH1/H0, DIMME1/E0, DIMMF1/F0. Please note that the memory notches should match the DIMM slots' notches. Insert each DIMM module vertically to prevent incorrect installation.

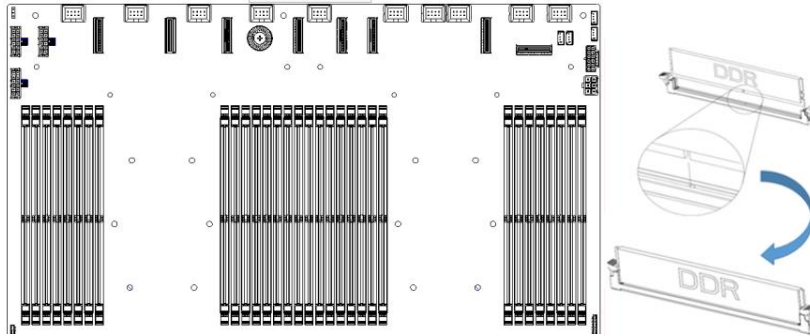

Figure 3-5

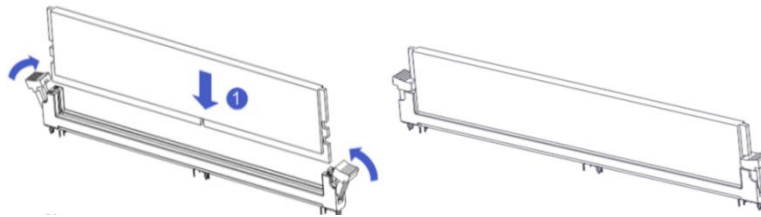



Figure 3-6

-  Note: On this motherboard, please use memory modules with the same CAS latency value. It is recommended to use memory of the same capacity and frequency produced by the same manufacturer.

3.2.4 Server slide rail installation

- Step 1: Prepare two slide rails and pull out the inner rail.

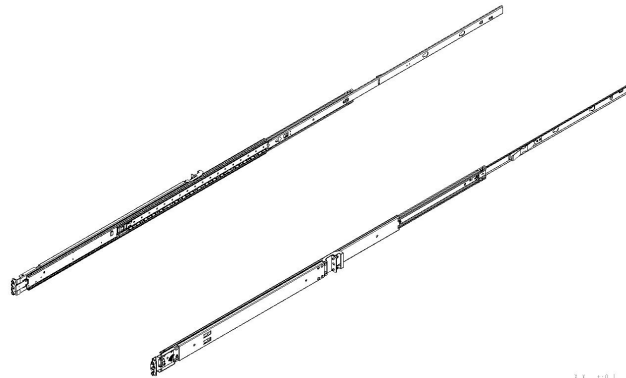

Figure 3-7

- Step 2: Fasten the inner rails to the sides of the chassis.

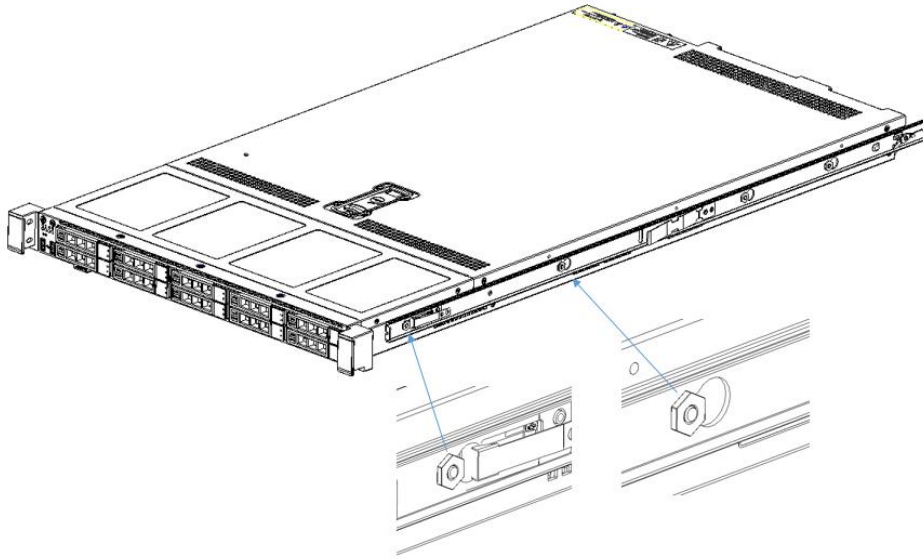

Figure 3-8

- Step 3: Install the outer rails on the cabinet brackets and secure the screws.

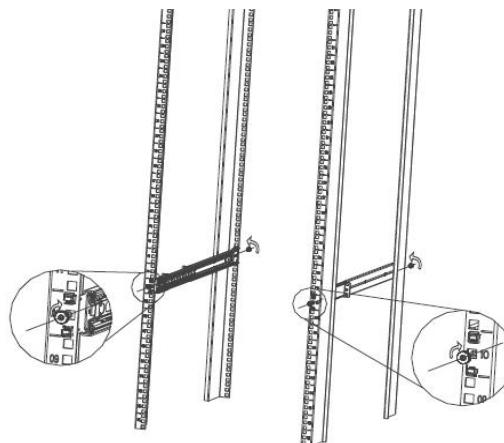

Figure 3-9

- ⚠ Note: When installing the guide rail, align it with the U-mark, and push it into place until you hear a click sound. Secure it firmly using M5 screws.
- Step 4: Align the chassis with the inner rails installed with the outer rails for installation.

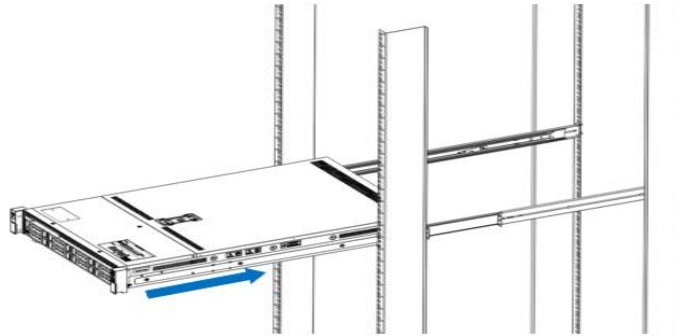



Figure 3-10

 Note: When you push the chassis forward, you will hear a snapping sound. If you can't push it, you need to pull down the buckle of the inner rail to continue to push the chassis gently.

- Step 5: Push the chassis forward until it cannot slide and make sure that the screws are securely installed to complete the installation.

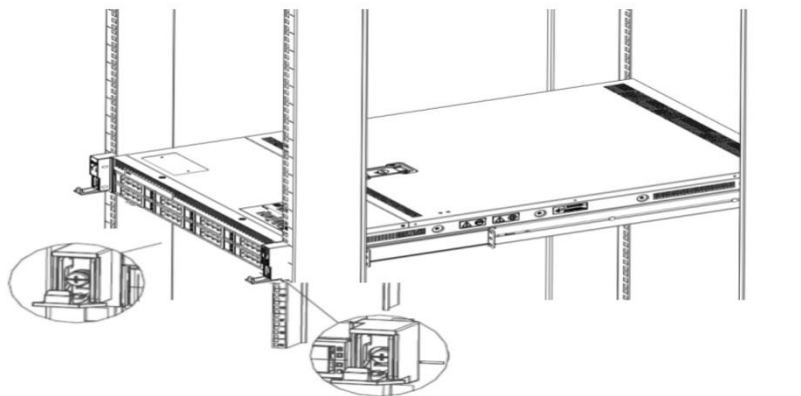



Figure 3-11

 Note: During equipment maintenance, it is necessary to loosen the panel screws and pull the chassis lightly. Do not push or pull the chassis at random speed to avoid damage to the equipment.

4. Configuration Instructions

4.1 Initial Configuration

4.1.1 Power on and start

- Before powering on, it is necessary to ensure that all configurations of the server are installed in accordance with the corresponding specifications and standards, and keep the server turned off but not unplugged from the power supply. And all cables are connected properly, and the power supply voltage is consistent with that of the device.
- During the power-on process, please do not plug in hard drives, power modules, network cables or other external devices and cables.
- If the server has just been unplugged from the power supply, please wait for 1 minute before turning on the power.
- Server power-on power status:
The power supply is powered on, but the server is not turned on, and the power indicator is flashing green.
Power on, the server starts up, and the power indicator light is green.
- How to power on the server:
The server's default power-on policy is "Power-On Boot," which means the server will automatically power on when it receives power. Users can modify this setting in the BIOS Setup interface.
- Press the or <ESC> key on the keyboard during the boot process to enter the BIOS Setup interface, and find the following interface:

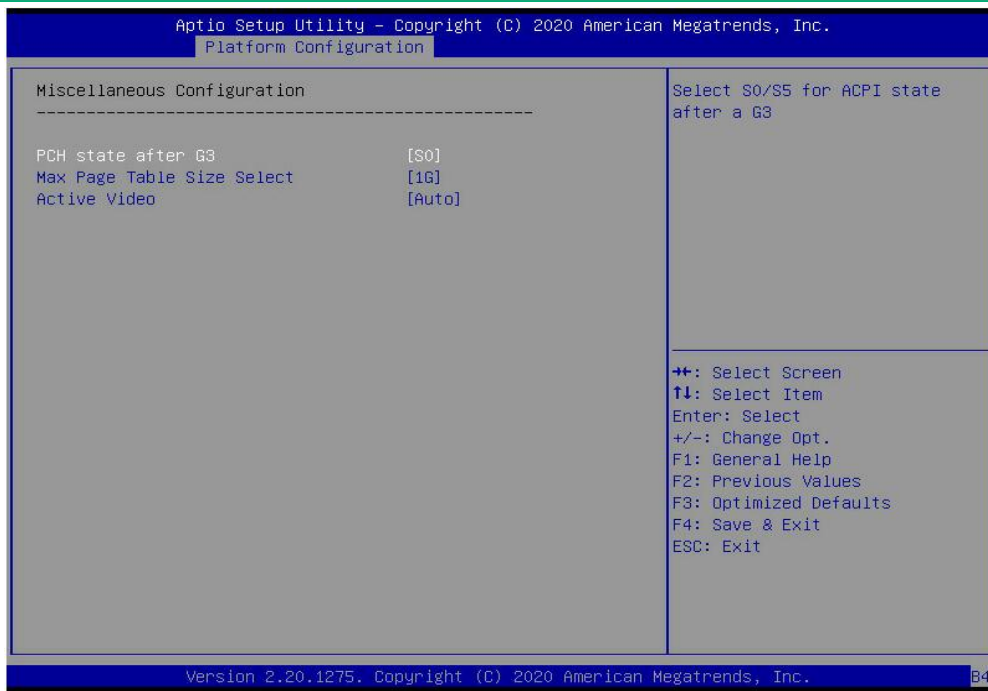



Figure 4-1

- PCH state after G3
PCH state setting after G3, the menu options are:
S0: Power on and start up directly
S5: You need to press the Power button to turn on the power
leave power state unchanged: Leave the power state unchanged .
Default: S0
- Log in to the iBMC management interface to perform remote power-on and power-off control.
- Enter the BMC IP address -> enter the BMC account&password -> find the remote control interface -> power controller -> It can be executed according to requirements.



Figure 4-2

 For detailed usage of BMC and BIOS, please refer to the corresponding user manual.

4.1.2 Initial data

- BMC default account: admin
- BMC default password: Server@123.
- BMC default address: 192.168.100.1
- BIOS Default Password: N/A

4.1.3 Configure BIOS

Press the or <ESC> key on the keyboard during power-on and start-up to enter the BIOS Setup interface, as shown below:

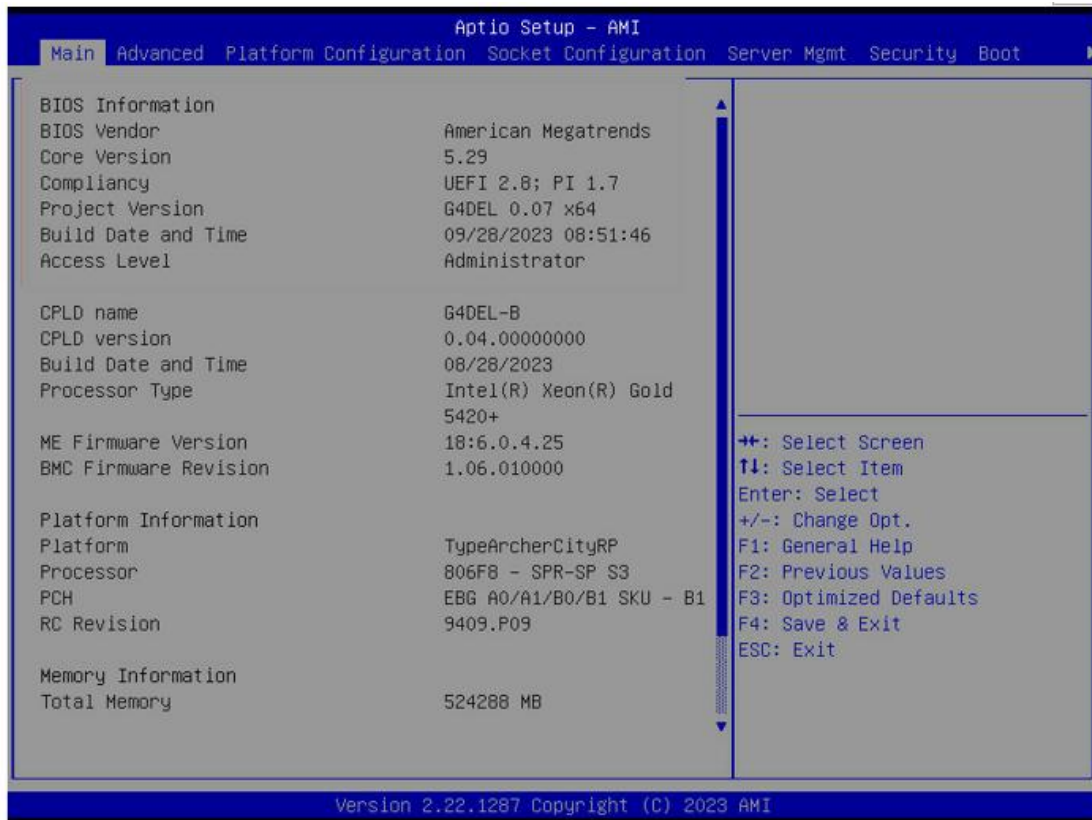

Figure 4-3

The Main interface contains the basic information of the BIOS system, such as the BIOS version number, CPU model, memory capacity, and the system time can be set. For detailed instructions, please refer to the "BIOS User Manual".

- Navigation key description:

→←: Select Screen

↑↓: Select Item

Enter: Select

+/-: Change Opt.

F1: General Help

F2: Previous Values

F3: Optimized Defaults

F4: Save & Reset

ESC: Exit

4.1.4 Configure BMC

When the server is powered on, make sure that the BMC dedicated

management network port cable is properly connected.

Use another device, make sure it is in the same LAN as the BMC management network, and enter the BMC IP address on the web page.

Check the BMC IP address as follows:

- After the server is powered on, turn it on. Pay attention to the POST process when starting the server. In the lower left corner of the logo screen, the IP address is displayed.
- After the server powers on, pay attention to the POST process. Press the or <ESC> key on the keyboard to enter the BIOS Setup interface. Switch to the following screen:

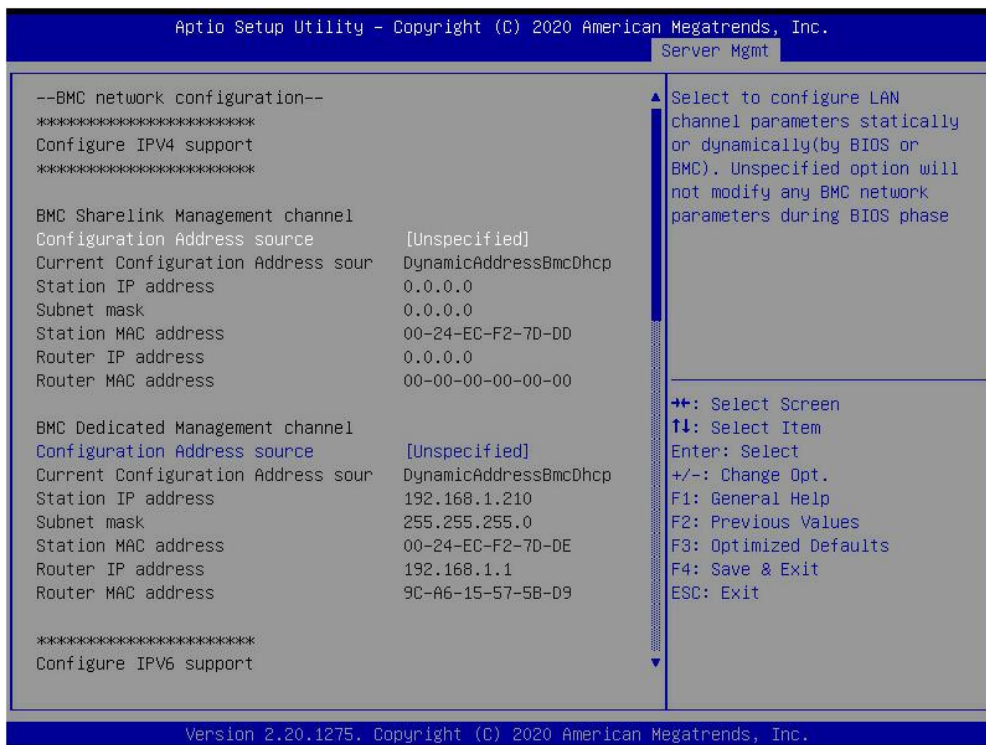

Figure 4-4

Configure IPV4 support :

- BMC sharelink Management Channel
- Configuration Address source
- Configure the BMC IP address allocation mode, the menu options are:

Unspecified: Do not change BMC parameters

Static: BIOS static IP setting

DynamicBmcDhcp: BMC runs DHCP to dynamically assign IP

DynamicBmcNonDhcp: BMC runs the Non-DHCP protocol to dynamically assign IP

Default: Unspecified

When changing from "Unspecified" to other parameters, saving and rebooting will result in the options reverting to the "Unspecified" value. There is no need to configure the BMC IP during every startup process.

- When the "Configuration Address Source" option is set to "Unspecified," it will display the network parameters (IPv4) for the system's shared Ethernet port. The displayed information includes the current IP configuration method, BMC IP, subnet mask, MAC address, router IP, and router MAC.

- BMC Dedicated Management Channel

- Configuration Address source

- Configure the BMC IP address allocation mode, the menu options are:
 - Unspecified: No change to BMC parameters
 - Static: BIOS static IP setting
 - DynamicBmcDhcp: BMC runs DHCP to dynamically assign IP
 - DynamicBmcNonDhcp: BMC runs the Non-DHCP protocol to dynamically assign IP
 - Default: Unspecified

- When changing from "Unspecified" to other parameters, saving and rebooting will result in the options reverting to the "Unspecified" value. There is no need to configure the BMC IP during every startup process.

- When the "Configuration Address Source" option is set to "Unspecified," it will display the network parameters (IPv4) for the system's dedicated Ethernet port. The displayed information includes the current IP configuration method, BMC IP, subnet mask, MAC address, router IP, and router MAC.

- Configure IPV6 support

- BMC Sharelink Management Channel

- IPV6 Support

- Choose whether to support IPV6, the menu options are:
 - Enabled: support IPV6
 - Disabled: does not support IPV6
 - Default: Enabled

- When changing from "Unspecified" to other parameters, saving and rebooting will result in the options reverting to the "Unspecified" value. There is no need to configure the BMC IP during every startup process.

- When the "Configuration Address Source" option is set to "Unspecified," it will display the network parameters (IPv6) for the system's shared Ethernet port.

- BMC Dedicated Management Channel

- IPV6 Support

- Choose whether to support IPV6, the menu options are:
 - Enabled: support IPV6

Disabled: does not support IPV6

Default: Enabled

- When changing from "Unspecified" to other parameters, saving and rebooting will result in the options reverting to the "Unspecified" value. There is no need to configure the BMC IP during every startup process.
- When the "Configuration Address Source" option is set to "Unspecified," it will display the network parameters (IPv6) for the system's dedicated Ethernet port.

Log in to the BMC management interface

Enter the IP address on the web page, as shown in the figure:

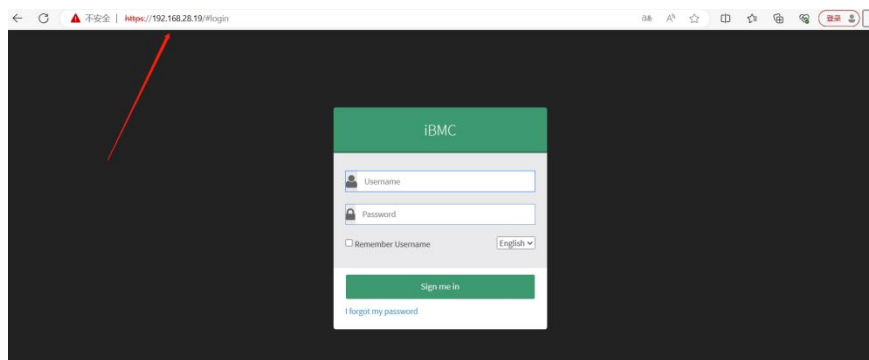

Figure 4-5

Enter the account password to enter the home page, and you can set the BMC IP address on the management interface.

On the left side of the interface, switch to "Settings Page" -> "Network Settings" -> "Network IP Settings". As shown below:

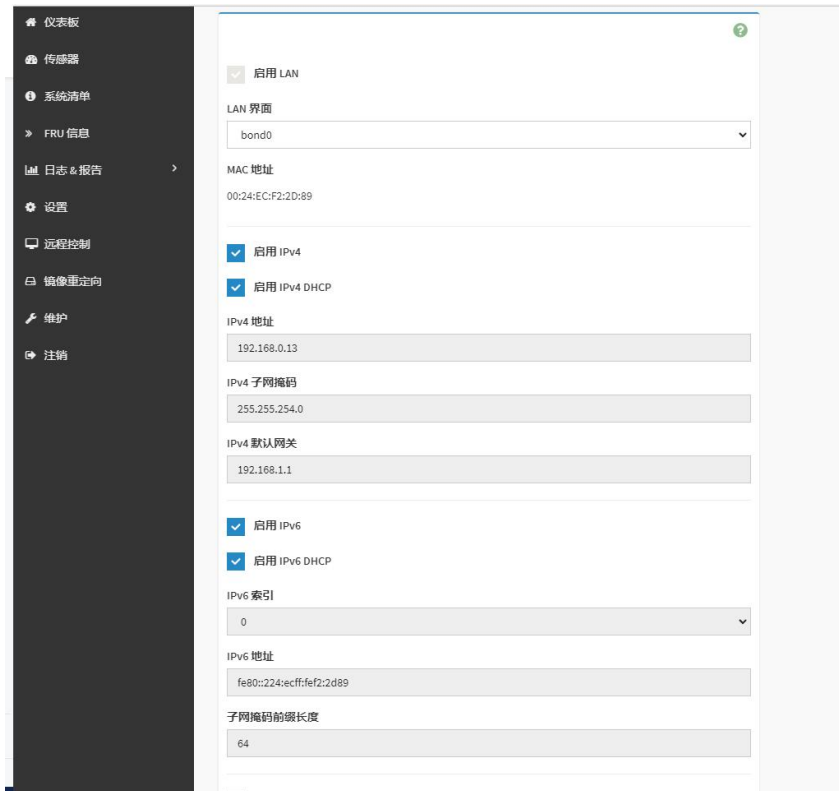

Figure 4-6

This page sets the IP address of the BMC management network port.

5. Appendix

(Common fault diagnosis)

No display after power on

- Make sure the monitor cable is properly connected and the power indicator on the monitor lights up when the monitor is powered on.
- Ensure the monitor is connected to the server.
- If the above steps do not resolve the issue, try replacing the monitor with a known working one to confirm if the original monitor is faulty.
- If the issue persists, please contact NAG's customer service department for resolution.

Front Panel Indicator Lights Alarm

- Refer to the instructions in the manual to determine the specific alarm information indicated by the front panel lights and buttons.
- For power failure indicator lights alarm, check if the power module indicator lights on the rear window of the server are abnormal.

If the power module indicator lights are normal, please log in to the BMC web interface to check the BMC logs for any alarms. If there are alarms, please record the specific alarm information and contact NAG's customer service department for resolution.

If the power module indicator lights are not normal, please ensure that the server, power module, and power cords are functioning correctly.

- For system alarm indicator lights, first check the external environment.
- For other indicator light alarms, please contact NAG's customer service department for resolution.

Abnormal Hard Drive Indicator Lights

- Ensure the hard drives are properly installed.
- Refer to the instructions in the manual to determine the specific alarm information indicated by the rear panel lights and buttons.

- Confirm if the RAID card is configured correctly.
- Check for any drive dropouts during OS installation. If this occurs, please contact NAG's customer service department for resolution.

Unable to Use RAID Card

- Ensure the RAID card is properly installed.
- Try reseating the RAID card and PCIe adapter to confirm if they are functioning correctly.
- If replacing the known working RAID card doesn't resolve the issue, please restore to factory settings and update the BIOS version. If the problem persists contact NAG's customer service department for further assistance and resolution.

IPMI Connection Failure

- Confirm if the BMC function is correctly enabled in the BIOS.
- Check if the switch and network cables are functioning properly. If the regular IPMI connection is not effective, check the network environment.
- Set static or dynamic IP and ensure ping connectivity. If the web interface does not open, try using a newer version of Internet Explorer.
- If the problem is not resolved, please contact NAG's customer service department for further assistance and resolution.
- Operating this device in a residential environment may cause radio interference.