

SFP+ Single-Mode for DWDM Application
Duplex SFP+ Transceiver
Digital Diagnostic Function
RoHS6 Compliant

Features

- ◆ Available in all C-Band Wavelengths on the 100GHz DWDM ITU Grid
- ◆ Data rates from 9.95 to 11.1Gbps
- ◆ Temperature-Stabilized DWDM EML Transmitter
- ◆ Duplex LC Connector
- ◆ Hot-Pluggable SFP+ Footprint
- ◆ Built-in Digital Diagnostic Functions as Specified in the SFF-8431 MSA
- ◆ Operating Case Temperature:
0°C to 70°C



Applications

- ◆ 10GBASE-ER/EW 10G Ethernet
- ◆ 1200-SM-LL-L 10G Fiber Channel
- ◆ SDH STM S-64.2b

Ordering Information:

Part No.	Data Rate	Laser	Power budget ^{*(note2)}	DDMI	Temperature
SNR-SFP+DXX-40 ^{*(note1)}	9.953~11.1Gbps	DWDM EML	14dB	YES	0°C to 70°C

Note1: XX refers to DWDM Wavelength channel as ITU-T specified, please refer the following table for detailed center wavelength information.

Note2: Over the G.652 SMF

X- Channel refers to the following table:

*Channel (X)	Part NO.	Frequency (THz)	Center Wavelength (nm)
15	SNR-SFP+D15-40	191.5	1565.50
16	SNR-SFP+D16-40	191.6	1564.68
17	SNR-SFP+D17-40	191.7	1563.86
18	SNR-SFP+D18-40	191.8	1563.05
19	SNR-SFP+D19-40	191.9	1562.23
20	SNR-SFP+D20-40	192.0	1561.42
21	SNR-SFP+D21-40	192.1	1560.61
22	SNR-SFP+D22-40	192.2	1559.79

23	SNR-SFP+D23-40	192.3	1558.98
24	SNR-SFP+D24-40	192.4	1558.17
25	SNR-SFP+D25-40	192.5	1557.36
26	SNR-SFP+D26-40	192.6	1556.55
27	SNR-SFP+D27-40	192.7	1555.75
28	SNR-SFP+D28-40	192.8	1554.94
29	SNR-SFP+D29-40	192.9	1554.13
30	SNR-SFP+D30-40	193.0	1553.33
31	SNR-SFP+D31-40	193.1	1552.52
32	SNR-SFP+D32-40	193.2	1551.72
33	SNR-SFP+D33-40	193.3	1550.92
34	SNR-SFP+D34-40	193.4	1550.12
35	SNR-SFP+D35-40	193.5	1549.32
36	SNR-SFP+D36-40	193.6	1548.51
37	SNR-SFP+D37-40	193.7	1547.72
38	SNR-SFP+D38-40	193.8	1546.92
39	SNR-SFP+D39-40	193.9	1546.12
40	SNR-SFP+D40-40	194.0	1545.32
41	SNR-SFP+D41-40	194.1	1544.53
42	SNR-SFP+D42-40	194.2	1543.73
43	SNR-SFP+D43-40	194.3	1542.94
44	SNR-SFP+D44-40	194.4	1542.14
45	SNR-SFP+D45-40	194.5	1541.35
46	SNR-SFP+D46-40	194.6	1540.56
47	SNR-SFP+D47-40	194.7	1539.77
48	SNR-SFP+D48-40	194.8	1538.98
49	SNR-SFP+D49-40	194.9	1538.19
50	SNR-SFP+D50-40	195.0	1537.40
51	SNR-SFP+D51-40	195.1	1536.61
52	SNR-SFP+D52-40	195.2	1535.82
53	SNR-SFP+D53-40	195.3	1535.04
54	SNR-SFP+D54-40	195.4	1534.25
55	SNR-SFP+D55-40	195.5	1533.47
56	SNR-SFP+D56-40	195.6	1532.68
57	SNR-SFP+D57-40	195.7	1531.90
58	SNR-SFP+D58-40	195.8	1531.12
59	SNR-SFP+D59-40	195.9	1530.33
60	SNR-SFP+D60-40	196.0	1529.55
61	SNR-SFP+D61-40	196.1	1528.77

*:Please contact with SNR the channel you need for the further detail.

Regulatory Compliance

Feature	Standard	Performance
Electrostatic Discharge (ESD) to the Electrical Pins	MIL-STD-883G Method 3015.7	Class 1C (>1000V)
Electrostatic Discharge to the Enclosure	EN 55024:1998+A1+A2 IEC-61000-4-2 GR-1089-CORE	Compliant with standards
Electromagnetic Interference (EMI)	FCC Part 15 Class B EN55022: 2006 CISPR 22B: 2006 VCCI Class B	Compliant with standards Noise frequency range: 30MHz to 6GHz. Good system EMI design practice required to achieve Class B margins. System margins are dependent on customer host board and chassis design.
Immunity	EN 55024:1998+A1+A2 IEC 61000-4-3	Compliant with standards. 1KHz sine-wave, 80% AM, from 80MHz to 1GHz. No effect on transmitter/receiver performance is detectable between these limits.
Laser Eye Safety	FDA 21CFR 10X.10 and 10X.11 EN (IEC) 60825-1: 2007 EN (IEC) 60825-2: 2004+A1	CDRH compliant and Class I laser product. TüV Certificate No. 50135086
Component Recognition	UL and CUL EN60950-1: 2006	UL file E317337 TüV Certificate No. 50135086 (CB scheme)
RoHS6	2002/95/EC 4.1&4.2 2005/747/EC 5&7&13	Compliant with standards ^{*note3}

Note3: For update of the equipments and strict control of raw materials, SNR has the ability to supply the customized products since Jan 1st, 2007, which meet the requirements of RoHS6 (Restrictions on use of certain Hazardous Substances) of European Union.

In light of item 5 in RoHS exemption list of RoHS Directive 2002/95/EC, Item 5: Lead in glass of cathode ray tubes, electronic components and fluorescent tubes.

In light of item 13 in RoHS exemption list of RoHS Directive 2005/747/EC, Item 13: Lead and cadmium in optical and filter glass. The three exemptions are being concerned for SNR's transceivers, because SNR's transceivers use glass, which may contain Pb, for components such as lenses, isolators, and other components.

Product Description

The SNR-SFP+DXX-40 series single mode transceiver is small form factor pluggable module for duplex optical data communications. This module is designed for single mode fiber and operates

at a nominal DWDM wavelength from 1528.77nm to 1563.86nm as specified by the ITU-T. It is designed to deploy in the DWDM networking equipment in metropolitan access and core networks.

It is with the SFP+ 20-pin connector to allow hot plug capability. The transmitter section uses a DWDM EML laser and is a class 1 laser compliant according to International Safety Standard IEC-60825. The receiver section uses a PIN detector and a limiting post-amplifier IC.

The SNR-SFP+DXX-40 series are designed to be compliant with SFP+ Multi-Source Agreement (MSA) Specification SFF-8431.

Absolute Maximum Ratings

Parameter	Symbol	Min.	Max.	Unit
Storage Temperature	Ts	-40	+85	°C
Supply Voltage	Vcc	-0.5	3.6	V
Operating Relative Humidity		-	95	%

*Exceeding any one of these values may destroy the device immediately.

Recommended Operating Conditions

Parameter	Symbol	Min.	Typical	Max.	Unit
Operating Case Temperature	T _A SNR-SFP+DXX-40	0		+70	°C
Power Supply Voltage	Vcc	3.15	3.3	3.45	V
Power Supply Current	Icc			600	mA
Data Rate		9.953		11.1	Gbps

Performance Specifications – Electrical

(T_{OP} = 0 to 70°C, V_{CC} = 3.15 to 3.45V)

Parameter	Symbol	Min.	Typ.	Max	Unit	Notes
Transmitter						
CML Inputs(Differential)	Vin	250		1000	mVpp	AC coupled input ^{*(note3)}
Input Impedance (Differential)	Zin	85	100	115	ohm	Rin > 100 kohm @ DC
TX_Dis	Disable	2		Vcc+0.3	V	
	Enable	0		0.8		
TX_FAULT	Fault	2		Vcc+0.3	V	
	Normal	0		0.5		
Receiver						
CML Outputs (Differential)	Vout	350		700	mVpp	AC coupled output ^{*(note3)}
Output Impedance (Differential)	Zout	85	100	115	ohm	

RX_LOS	LOS		2		V _{CC} +0.3	V	
	Normal		0		0.8	V	
MOD_DEF (0:2)		VoH	2.5			V	With Serial ID
		VoL	0		0.5	V	

Performance Specifications – Optical

(T_{OP} = 0 to 70°C, V_{CC} = 3.15 to 3.45V)

Parameter	Symbol	Min.	Typical	Max.	Unit
Data Rate		9.953		11.1	Gbps
Transmitter					
Center Wavelength Spacing			100		GHz
			0.8		nm
Side Mode Suppression Ratio	SMSR	30			dB
Average Output Power ^{*(note4)}	P _{out}	-2		3	dBm
Average Launch Power (Tx: OFF)	P _{off}			-30	dBm
Extinction Ratio	ER	8.2			dB
P _{out} @TX Disable Asserted	P _{out}			-45	dBm
Relative Intensity Noise	RIN			-128	dB/Hz
TX Jitter	TX _j	Per 802.3ae requirements			
Receiver					
Receiver Sensitivity ^{*(note5)}	P _{min}			-16	dBm
Receiver Overload	P _{max}	+0.5			dBm
LOS De-Assert	LOSD			-17	dBm
LOS Assert	LOSA	-28			dBm
LOS Hysteresis		1			dB

Note3: CML logic, internally AC coupled.

Note4: Output is coupled into a 9/125µm single-mode fiber.

Note5: Minimum average optical power measured at the BER less than 1E-12. The measure pattern is PRBS 2³¹-1.

SFP+ Transceiver Electrical Pad Layout

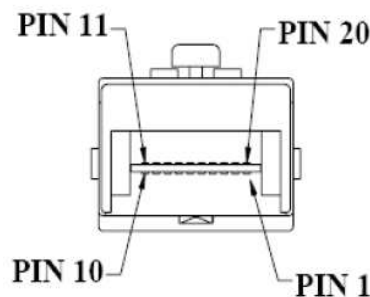

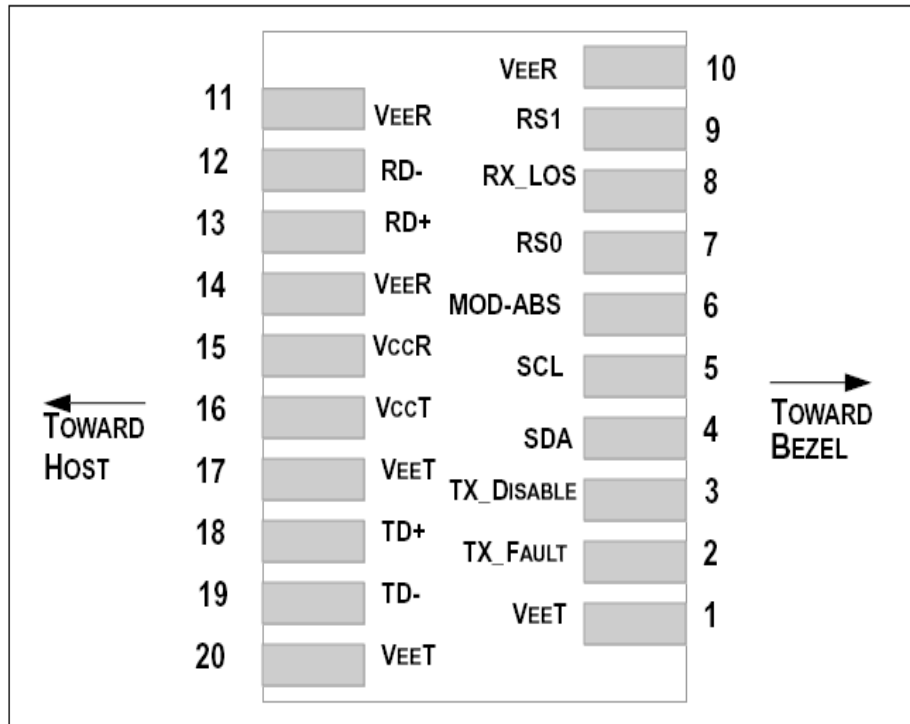

Pin Function Definition

Pin Num.	Name	FUNCTION	Plug Seq.	Notes
1	VeeT	Transmitter Ground	1	Note 5
2	TX Fault	Transmitter Fault Indication	3	Note 1
3	TX Disable	Transmitter Disable	3	Note 2, Module disables on high or open
4	SDA	Module Definition 2	3	Note 3, Data line for Serial ID.
5	SCL	Module Definition 1	3	Note 3, Clock line for Serial ID.
6	MOD-ABS	Module Definition 0	3	Note 3
7	RS0	RX Rate Select (LVTTTL).	3	This pin has an internal 30k pull down to ground. A signal on this pin will not affect module performance.
8	LOS	Loss of Signal	3	Note 4
9	RS1	TX Rate Select (LVTTTL).	1	This pin has an internal 30k pull down to ground. A signal on this pin will not affect module performance.
10	VeeR	Receiver Ground	1	Note 5

11	VeeR	Receiver Ground	1	Note 5
12	RD-	Inv. Received Data Out	3	Note 6
13	RD+	Received Data Out	3	Note 7
14	VeeR	Receiver Ground	1	Note 5
15	VccR	Receiver Power	2	3.3 ± 5%, Note 7
16	VccT	Transmitter Power	2	3.3 ± 5%, Note 7
17	VeeT	Transmitter Ground	1	Note 5
18	TD+	Transmit Data In	3	Note 8
19	TD-	Inv. Transmit Data In	3	Note 8
20	VeeT	Transmitter Ground	1	Note 5

Notes:

1) TX Fault is an open collector/drain output, which should be pulled up with a 4.7K – 10KΩ resistor on the host board. Pull up voltage between 2.0V and VccT, R+0.3V. When high, output indicates a laser fault of some kind. Low indicates normal operation. In the low state, the output will be pulled to < 0.8V.

2) TX disable is an input that is used to shut down the transmitter optical output. It is pulled up within the module with a 4.7 – 10 KΩ resistor. Its states are:

Low (0 – 0.8V): Transmitter on

(>0.8, < 2.0V): Undefined

High (2.0 – 3.465V): Transmitter Disabled

Open: Transmitter Disabled

3) Modulation Absent, connected to VEET or VEER in the module.

4) LOS (Loss of Signal) is an open collector/drain output, which should be pulled up with a 4.7K – 10KΩ resistor. Pull up voltage between 2.0V and VccT, R+0.3V. When high, this output indicates the received optical power is below the worst-case receiver sensitivity (as defined by the standard in use). Low indicates normal operation. In the low state, the output will be pulled to < 0.8V.

5) VeeR and VeeT may be internally connected within the SFP+ module.

6) RD-/+ : These are the differential receiver outputs. They are AC coupled 100Ω differential lines which should be terminated with 100Ω (differential) at the user SERDES. The AC coupling is done inside the module and is thus not required on the host board.

7) VccR and VccT are the receiver and transmitter power supplies. They are defined as 3.3V ±5% at the SFP+ connector pin. Maximum supply current is 300Ma. Inductors with DC resistance of less than 1 ohm should be used in order to maintain the required voltage at the SFP+ input pin with 3.3V supply voltage. When the recommended supply-filtering network is used, hot plugging of the SFP+ transceiver module will result in an inrush current of no more than 30Ma greater than the steady state value. VccR and VccT may be internally connected within the SFP+ transceiver

module.

8) TD-/+: These are the differential transmitter inputs. They are AC-coupled, differential lines with 100Ω differential termination inside the module. The AC coupling is done inside the module and is thus not required on the host board.

EEPROM

The optical transceiver contains an EEPROM. It provides access to sophisticated identification information that describes the transceiver’s capabilities, standard interfaces, manufacturer, and other information.

The serial interface uses the 2-wire serial CMOS EEPROM protocol. When the serial protocol is activated, the host generates the serial clock signal (SCL, Mod Def 1). The positive edge clocks data into those segments of the EEPROM that are not writing protected within the SFP+ transceiver. The negative edge clocks data from the SFP+ transceiver. The serial data signal (SDA, Mod Def 2) is bi-directional for serial data transfer. The host uses SDA in conjunction with SCL to mark the start and end of serial protocol activation. The memories are organized as a series of 8-bit data words that can be addressed individually or sequentially.

The module provides diagnostic information about the present operating conditions. The transceiver generates this diagnostic data by digitization of internal analog signals. Alarm/warning threshold data is written during device manufacture. TEC current monitoring, laser temperature monitoring, received power monitoring, transmitted power monitoring, bias current monitoring, supply voltage monitoring and transceiver temperature monitoring all are implemented. The diagnostic data are internal calibration and stored in memory locations 96 – 109 at wire serial bus address A2h. The transceiver memory map specific data field defines as following.

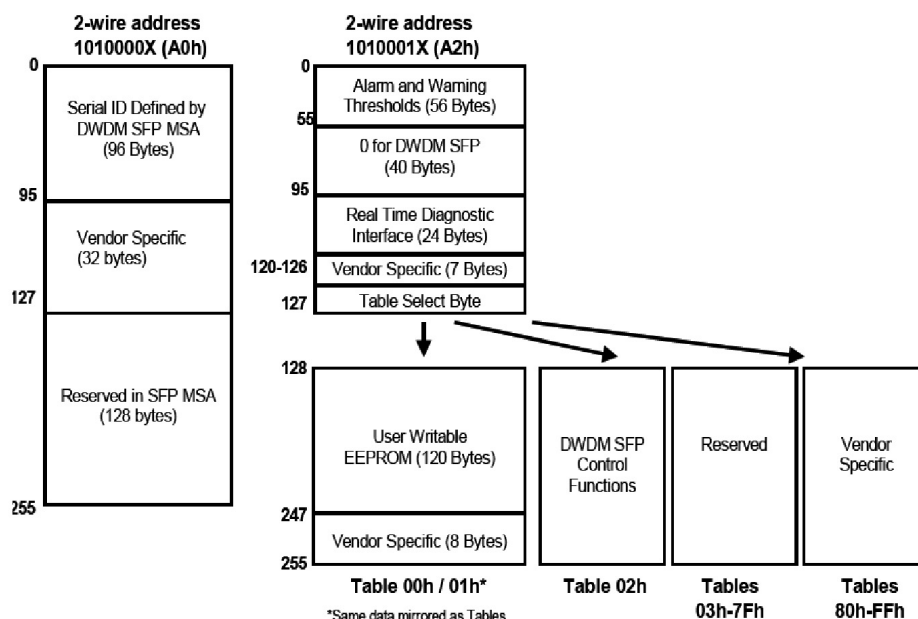

*Same data mirrored as Tables 00 and 01 for best compatibility with legacy SFF-8472 hosts

Recommend Circuit Schematic

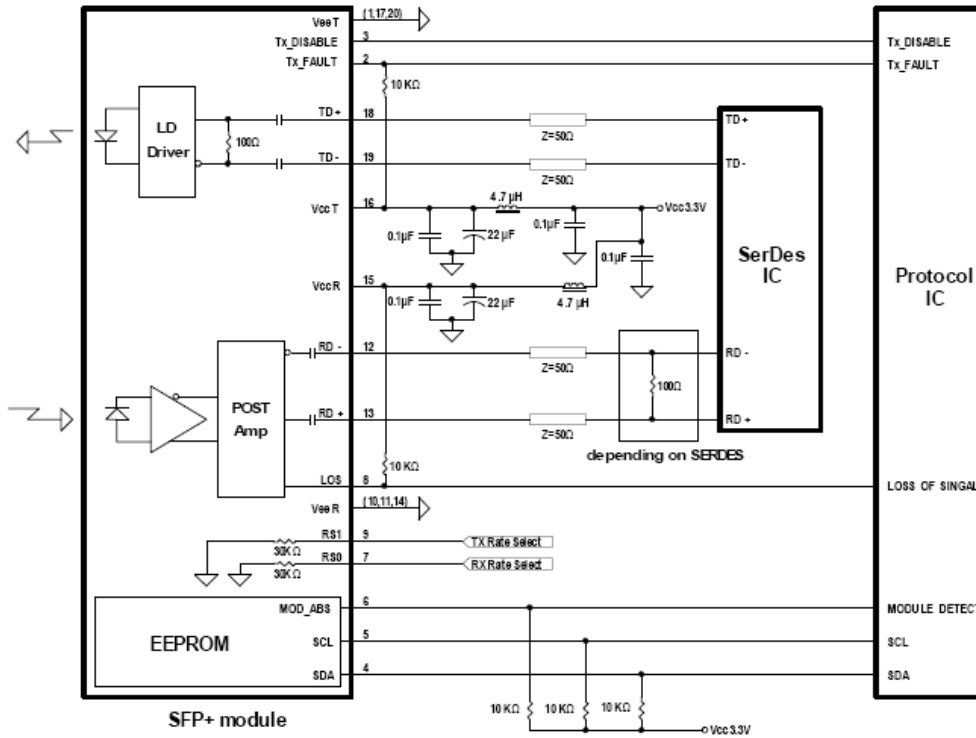

Mechanical Specifications

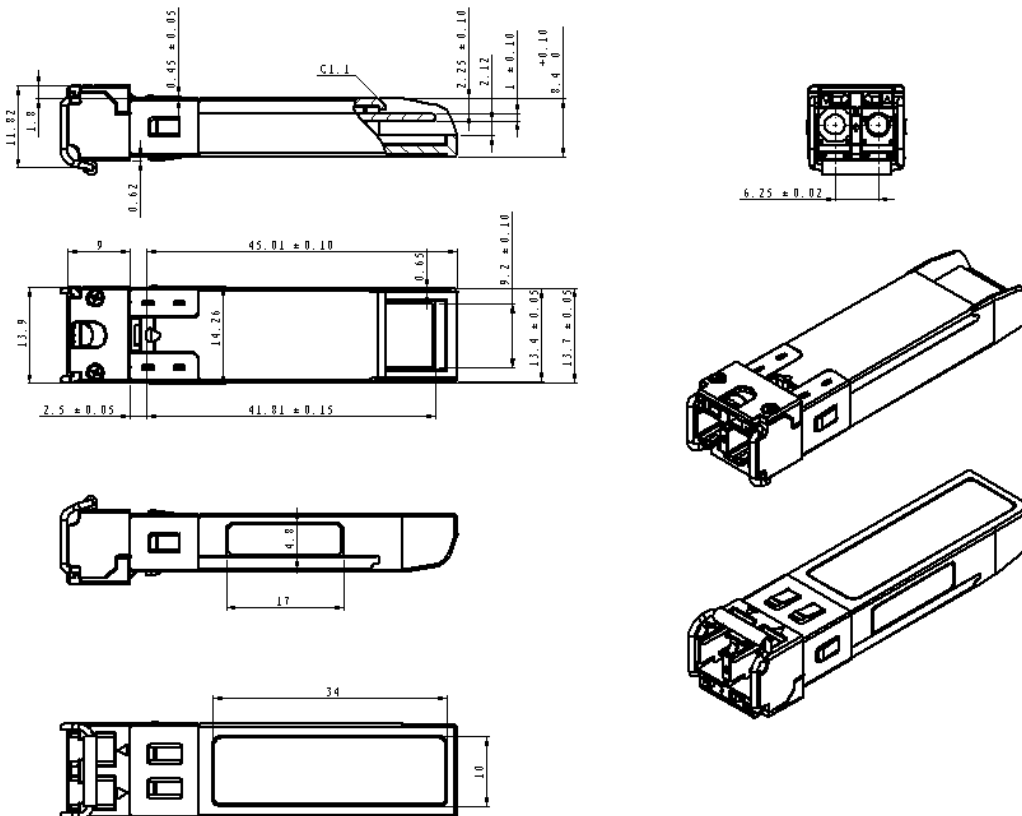

Class 1 Labels

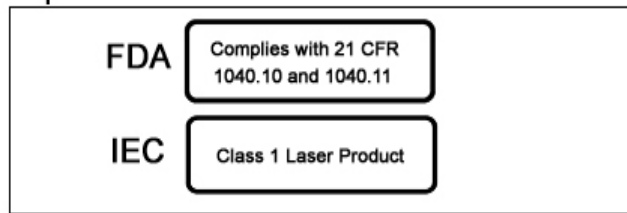

Laser Emission



Notice:

SNR reserves the right to make changes to or discontinue any optical link product or service identified in this publication, without notice, in order to improve design and/or performance. Applications that are described herein for any of the optical link products are for illustrative purposes only. SNR makes no representation or warranty that such applications will be suitable for the specified use without further testing or modification.

GUARANTEE:



CONTACT:

Address: Building 118, Vonsovskogo Street 1, Yekaterinburg, Russia

Tel: +7(343) 379-98-38

Fax: +7(343) 379-98-38

E-mail: info@nag.ru

Online shop: <http://shop.nag.ru>