

## SNR-QSFP28-DA-XX

QSFP Passive Cable Assemblies, 1m/2m/3m

Reach RoHS6 Compliant

### Features

- ◆ Supports 103.125Gb/s and 111.8Gb/s bit rates
- ◆ Lower Power Consumption for Single Module < 0.5W
- ◆ 30AWG up to 3 meters distance
- ◆ Power Supply: +3.3V
- ◆ Compatible to SFF-8436
- ◆ Temperature Range: 0~ 70°C
- ◆ RoHS6 Compliant



### Applications

- ◆ 100G Ethernet
- ◆ OTU4

# SNR-QSFP28-DA-XX

## Regulatory Compliance\*<sup>Note1</sup>

Product Certificate	Certificate Number	Applicable Standard
TUV	R50135086	EN 60950-1:2006+A11+A1+A12+A2
		EN 60825-1:2014
		EN 60825-2:2004+A1+A2
UL	E317337	UL 60950-1
		CSA C22.2 No. 60950-1-07
EMC CE	AE 50285865 0001	EN 55022:2010
		EN 55024:2010
FCC	WTF14F0514417E	47 CFR PART 15 OCT., 2013
FDA	/	CDRH 1040.10
ROHS	/	2011/65/EU

Note1: The above certificate number updated to June 2014, because some certificate will be updated every year, such as FDA and ROHS. For the latest certification information, please check with NAG.

## Product Description

Passive Copper Cable assemblies are high-performance, cost effective I/O solutions for 100 GB Ethernet and OTU4 applications. QSFP28 copper modules allow hardware manufacturers to achieve high port density, configurability and utilization at a very low cost and to reduce power budget.

## Absolute Maximum Ratings\*<sup>Note2</sup>

Parameter	Symbol	Min	Typ	Max	Units
Maximum Supply Voltage	V <sub>cc</sub>	-0.5		4.0	V
Storage Temperature	T <sub>s</sub>	-40		85	°C

Note2: Exceeding any one of these values may destroy the device immediately.

## Normal operating condition

Parameter	Symbol	Min	Typ	Max	Units	Notes
Operating Case Temperature	T <sub>c</sub>	0		70	°C	
Supply Voltage	V <sub>cc</sub>	3.135	3.3	3.465	V	
Power Consumption	P			0.5	W	Note3
Data Rate(per channel)				27.95	Gbps	

Note3: The power consumption value is just depended on single module.

## Performance Specifications – Electrical

Parameter	Symbol	Min.	Typ.	Max	Unit	Notes
Transmitter Differential Input Voltage	V <sub>IN</sub>	500	-	1200	mV <sub>pp</sub>	
Impedance	Z <sub>cabl</sub>	90	100	110	Ohms	

# SNR-QSFP28-DA-XX

## QSFP28 Transceiver Electrical Pad Layout

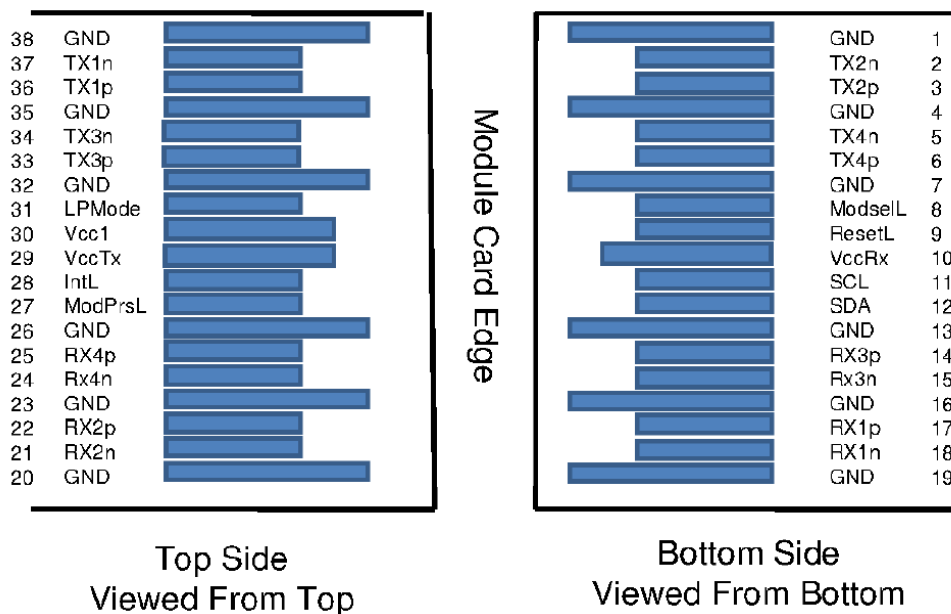

### Pin Function Definitions

Pin	Logic	Symbol	Description	Plug Sequence	Notes
1		GND	Ground	1	1
2	CML-I	Tx2n	Transmitter Inverted Data Input	3	
3	CML-I	Tx2p	Transmitter Non-Inverted Data Input	3	
4		GND	Ground	1	1
5	CML-I	Tx4n	Transmitter Inverted Data Input	3	
6	CML-I	Tx4p	Transmitter Non-Inverted Data Input	3	
7		GND	Ground	1	1
8	LVTTL-I	ModSelL	Module Select	3	
9	LVTTL-I	ResetL	Module Reset	3	
10		VccRx	+3.3V Power Supply Receiver	2	2
11	LVC MOS- I/O	SCL	2-wire serial interface clock	3	
12	LVC MOS- I/O	SDA	2-wire serial interface data	3	
13		GND	Ground	1	1
14	CML-O	Rx3p	Receiver Non-Inverted Data Output	3	
15	CML-O	Rx3n	Receiver Inverted Data Output	3	
16		GND	Ground	1	1
17	CML-O	Rx1p	Receiver Non-Inverted Data Output	3	
18	CML-O	Rx1n	Receiver Inverted Data Output	3	
19		GND	Ground	1	1
20		GND	Ground	1	1
21	CML-O	Rx2n	Receiver Inverted Data Output	3	

## SNR-QSFP28-DA-XX

22	CML-O	Rx2p	Receiver Non-Inverted Data Output	3	
23		GND	Ground	1	1
24	CML-O	Rx4n	Receiver Inverted Data Output	3	
25	CML-O	Rx4p	Receiver Non-Inverted Data Output	3	
26		GND	Ground	1	1
27	LVTTL-O	ModPrsL	Module Present	3	
28	LVTTL-O	IntL	Interrupt	3	
29		VccTx	+3.3V Power supply transmitter	2	2
30		Vcc1	+3.3V Power supply	2	2
31	LVTTL-I	LPMode	Low Power Mode	3	
32		GND	Ground	1	1
33	CML-I	Tx3p	Transmitter Non-Inverted Data Input	3	
34	CML-I	Tx3n	Transmitter Inverted Data Input	3	
35		GND	Ground	1	1
36	CML-I	Tx1p	Transmitter Non-Inverted Data Input	3	
37	CML-I	Tx1n	Transmitter Inverted Data Input	3	
38		GND	Ground	1	1

1: GND is the symbol for signal and supply (power) common for the QSFP+ module. All are common within the QSFP+ module and all module voltages are referenced to this potential unless otherwise noted. Connect these directly to the host board signal-common ground plane.

2: Vcc Rx, Vcc1 and Vcc Tx are the receiver and transmitter power supplies and shall be applied concurrently. Requirements defined for the host side of the Host Edge Card Connector are listed in Table 6. Recommended host board power supply filtering is shown in Figures 3 and 4. Vcc Rx Vcc1 and Vcc Tx may be internally connected within the QSFP+ Module in any combination. The connector pins are each rated for a maximum current of 500mA.

# Memory Map

2-Wire Serial Address: 1010000x

0	ID and status	(3 Bytes)
2		
21	Interrupt Flags	(19 Bytes)
33	Module Monitors	(12 Bytes)
81	Channel Monitors	(48 Bytes)
85	Reserved	(4 Bytes)
97	Control	(12 Bytes)
99	Reserved	(2 Bytes)
106	Free Side Device and Channel Mask	(7 Bytes)
107	Reserved	(1 Bytes)
111	Free Side Device Properties	(4 Bytes)
118	Reserved	(7 Bytes)
122	Password Change Entry Area (Optional)	(4 Bytes)
126	Password Entry Area (Optional)	(4 Bytes)
127	Page Select Byte	(1 Bytes)

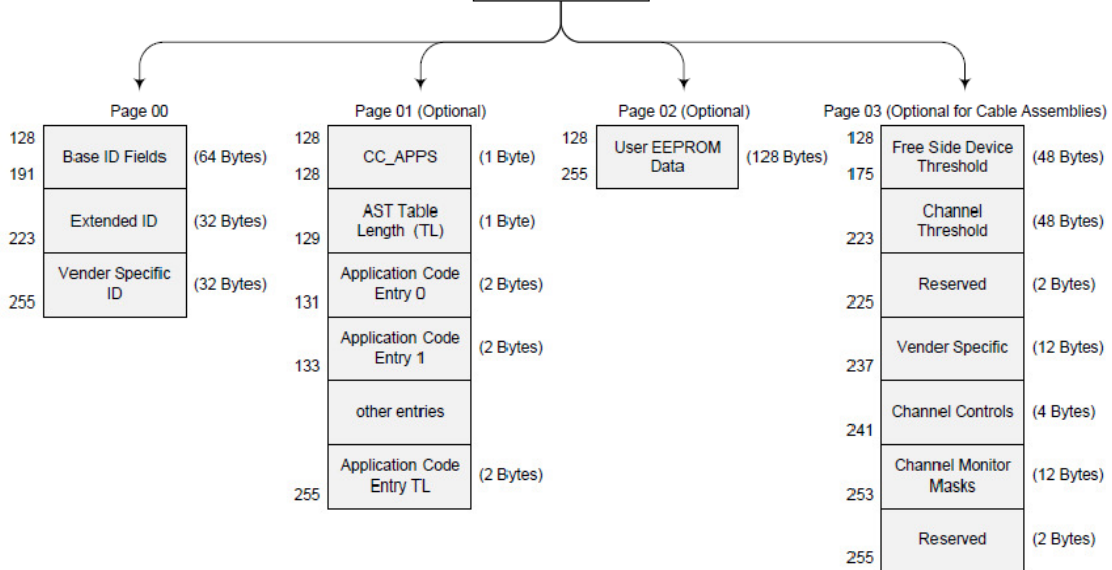

## EEPROM Serial ID Memory Contents

EEPROM Address		Page00h	Version	V1.0	
Data Addr	Field Size (Byte)	Name Of filed	Description of field	Coded value	Hex
<b>BASE ID FIELDS</b>					
128	1	Identifier	Type of serial transceiver	QSFP28	11
129	1	Ext.Identifier	Extended identifier of Type of serial transceiver	Power class 1 module, No CLEI code present in page 02h, No CDR in TX and RX	00
130	1	Connector	Code for connector type	No separable connector	23
131	8	Specification compliance	Ethernet Compliance Code	100GBASE-CR4	0B
132			SONET Compliance codes		00
133			SAS/SATA compliance codes		00
134			Gigabit Ethernet Compliant codes		00
135			Fibre Channel link length/Transmitter Technology		41
136			Fibre Channel link length/Transmitter Technology		80
137			Fibre Channel transmission media		80
138			Fibre Channel Speed		00
139	1	EncodingCode	for serial encoding algorithm		00
140	1	BR, Nominal	Nominal bit rate, units of 100 Mbits/sec.	27.95Gbps	FF
141	1	Extended rateselect Compliance	Tags for extended rate select compliance		00
142	1	Length(SMF)	Link length supported for SMF fiber in km		00
143	1	Length(OM3 50um)	Link length supported for EBW 50/125 um fiber (OM3), units of 2m		00
144	1	Length(OM2 50um)	Link length supported for 50/125 um fiber (OM2), units of 1m		00
145	1	Length(OM1 62.5 um)	Link length supported for 62.5/125 um fiber (OM1), units of 1m		00
146	1	Length (Copper)	Link length of copper or active cable, units of 1m	x(m) Note4	xx

## SNR-QSFP28-DA-XX

147	1	Device tech	Device technology	Copper cable unequalized, No wavelength control, Uncooled transmitter device, Transmitter not tunable	A0
148	16	Vendor name	Vendor name (ASCII)	E	45
149				o	6F
150				p	70
151				t	74
152				o	6F
153				l	6C
154				i	69
155				n	6E
156				k	6B
157				<space>	20
158				<space>	20
159				<space>	20
160				<space>	20
161				<space>	20
162				<space>	20
163				<space>	20
164	1	Extended Module	Extended Module codes for InfiniBand	QDR, DDR, SDR	07
165	3	Vendor OUI	QSFP+ vendor IEEE company ID		00
166					00
167					00
168	16	Vendor PN	Part number provided by vendor (ASCII)	E	45
169				O	4F
170				L	4C
171				Q	51
172				-	2D
173				1	31
174				H	48
175				G	47
176				-	2D
177				C	43
178				-	2D
179				x Note4	xx
180				x Note4	xx
181				x Note4	xx
182				x Note4	xx
183				P	50

## SNR-QSFP28-DA-XX

184	2	Vendor rev	Revision level for part number provided by vendor (ASCII)	A	41
185					20
186	2	Wave length or Copper cable Attenuation	Nominal laser wavelength (wavelength=value/20 in nm) or copper cable attenuation in dB at 2.5GHz (Adrs 186) and 5.0GHz (Adrs 187)	Fill in attenuation @ 2.5GHz in dB	xx
187					xx
188	2	Wavelength tolerance	Guaranteed range of laser wavelength(+/- value) from nominal wavelength.(wavelength Tol.=value/200 in nm)		00
189					00
190	1	Max case temp.	Maximum case temperature in degrees C	70°C	46
191	1	CC_BASE	Check code for Base ID Fields (addresses 128-190)	Note5	xx
192	4	Options	Rate Select, TX Disable, TX Fault, LOS, Warning indicators for: Temperature, VCC, RX power, TX Bias		00
193				RX output amplitude programming not implemented	00
194				Rx Squelch Disable not implemented; Rx Output Disable capable not implemented; Tx Squelch Disable not implemented; Tx Squelch not implemented	00
195				Memory page 02 not provided; Memory page 01 not provided; RATE_SELECT not implemented; Tx_DISABLE not implemented; Tx_FAULT signal not implemented; Tx Squelch not implemented to reduce Pave; Tx Loss of Signal not implemented	00
196	16	Vendor SN	Serial number provided by vendor (ASCII)	x	xx
197				x	xx
198				x	xx
199				x	xx
200				x	xx
201				x	xx
202				x	xx
203				x	xx



## SNR-QSFP28-DA-XX

204				x	xx
205				x	xx
206				<Space>	20
207				<Space>	20
208				<Space>	20
209				<Space>	20
210				<Space>	20
211				<Space>	20
212	8	Date code	Vendor's manufacturing date code	Year	xx
213				Year	xx
214				Month	xx
215				Month	xx
216				Day	xx
217				Day	xx
218				<Space>	20
219				<Space>	20
220	1	Diagnostic Monitoring Type	Indicates which types of diagnostic monitoring are implemented (if any) in the Module. Bit 1,0 Reserved		00
221	1	Enhanced Options	Indicates which optional enhanced features are implemented in the Module	Module does not support rate selection;Module does not support application select and page 01 does not exist	00
222	1	Reserved			00
223	1	CC_EXT	Check code for the Extended ID Fields (addresses 192-222)	Note6	xx
<b>Vendor Specific ID Fields</b>					
224-255	32	Vendor Specific EEPROM			00
<b>Note4:</b> The value on these addresses is according to specific QSFP+ pat number.					
<b>Note5:</b> The check code shall be the low order 8 bits of the sum of the contents of all the bytes from byte 128to byte 190, inclusive.					
<b>Note6:</b> The check code shall be the low order 8 bits of the sum of the contents of all the bytes from byte 192 to byte 222,, inclusive.					

## SNR-QSFP28-DA-XX

EEPROM Address			Page 03h	Version	
Data Addr	Field Size (Byte)	Name Of filed	Description of field	Coded value	Hex
<b>Alarm &amp; Warning Thresholds</b>					
128	2	Temp High Alarm	Temp High Alarm	+80°C	50H
129					00H
130	2	Temp Low Alarm	Temp Low Alarm	-5°C	FBH
131					00H
132	2	Temp High Warning	Temp High Warning	+75°C	4BH
133					00H
134	2	Temp Low Warning	Temp Low Warning	0°C	00H
135					00H
136-143	8	Reserved			00H
144	2	Voltage High Alarm	Voltage High Alarm	3.6V	8CH
145					A0H
146	2	Voltage Low Alarm	Voltage Low Alarm	3.0V	75H
147					30H
148	2	Voltage High Warning	Voltage High Warning	3.5V	88H
149					B8H
150	2	Voltage Low Warning	Voltage Low Warning	3.05V	77H
151					24H
152-159	8	Reserved			00H
160-175	16	Vendor Specific			00H
176	2	RX Power High Alarm	RX Power High Alarm		00H
177					00H
178	2	RX Power Low Alarm	RX Power Low Alarm		00H
179					00H
180	2	RX Power High Warning	RX Power High Warning		00H
181					00H
182	2	RX Power Low Warning	RX Power Low Warning		00H
183					00H
184	2	Tx Bias High Alarm	Tx Bias High Alarm		00H
185					00H
186	2	Tx Bias Low Alarm	Tx Bias Low Alarm		00H
187					00H
188	2	Tx Bias High Warning	Tx Bias High Warning		00H
189					00H
190	2	Tx Bias Low Warning	Tx Bias Low Warning		00H

## SNR-QSFP28-DA-XX

191					00H
192-199	8	Reserved			00H
200-207	8	Reserved			00H
208-223	16	Vendor Specific			00H
224-225	2	Reserved			00H
226-237	12	Reserved			00H
238	1	RX1 output amplitude	Output amplitude levels with no equalization enabled		00H
		RX2 output amplitude	Output amplitude levels with no equalization enabled		
239	1	RX3 output amplitude	Output amplitude levels with no equalization enabled		00H
		RX4 output amplitude	Output amplitude levels with no equalization enabled		
240	1	Rx4 SQ Disable	Rx Squelch Disable Channel 4		00H
		Rx3 SQ Disable	Rx Squelch Disable Channel 3		
		Rx2 SQ Disable	Rx Squelch Disable Channel 2		
		Rx1 SQ Disable	Rx Squelch Disable Channel 1		
		Tx4 SQ Disable	Tx Squelch Disable Channel 4		
		Tx3 SQ Disable	Tx Squelch Disable Channel 3		
		Tx2 SQ Disable	Tx Squelch Disable Channel 2		
241	1	Rx4 Output Disable	Rx Output Disable channel 4		00H
		Rx3 Output Disable	Rx Output Disable channel 3		
		Rx2 Output Disable	Rx Output Disable channel 2		
		Rx1 Output Disable	Rx Output Disable channel 1		
242	1	M-Rx1 Power High Alarm	Masking Bit for high RX Power alarm channel 1		00H
		M-Rx1 Power Low Alarm	Masking Bit for low RX Power alarm channel 1		
		M-Rx1 Power High Warning	Masking Bit for high RX Power warning channel 1		
		M-Rx1 Power Low Warning	Masking Bit for low RX Power warning channel 1		
		M-Rx2 Power High Alarm	Masking Bit for high RX Power alarm channel 2		
		M-Rx2 Power Low Alarm	Masking Bit for low RX Power alarm channel 2		

## SNR-QSFP28-DA-XX

		M-Rx2 Power High Warning	Masking Bit for high RX Power warning channel 2		
		M-Rx2 Power Low Warning	Masking Bit for low RX Power warning channel 2		
243	1	M-Rx3 Power High Alarm	Masking Bit for high RX Power alarm channel 3		00H
		M-Rx3 Power Low Alarm	Masking Bit for low RX Power alarm channel 3		
		M-Rx3 Power High Warning	Masking Bit for high RX Power warning channel 3		
		M-Rx3 Power Low Warning	Masking Bit for low RX Power warning channel 3		
		M-Rx4 Power High Alarm	Masking Bit for high RX Power alarm channel 4		
		M-Rx4 Power Low Alarm	Masking Bit for low RX Power alarm channel 4		
		M-Rx4 Power High Warning	Masking Bit for high RX Power warning channel 4		
		M-Rx4 Power Low Warning	Masking Bit for low RX Power warning channel 4		
244	1	M-Tx1 Bias High Alarm	Masking Bit for high TX Bias alarm channel 1		00H
		M-Tx1 Bias Low Alarm	Masking Bit for low TX Bias alarm channel 1		
		M-Tx1 Bias High Warning	Masking Bit for high TX Bias warning channel 1		
		M-Tx1 Bias Low Warning	Masking Bit for low TX Bias warning channel 1		
		M-Tx2 Bias High Alarm	Masking Bit for high TX Bias alarm channel 2		
		M-Tx2 Bias Low Alarm	Masking Bit for low TX Bias alarm channel 2		
		M-Tx2 Bias High Warning	Masking Bit for high TX Bias warning channel 2		
		M-Tx2 Bias Low Warning	Masking Bit for low TX Bias warning channel 2		
245	1	M-Tx3 Bias High Alarm	Masking Bit for high TX Bias alarm channel 3		00H
		M-Tx3 Bias Low Alarm	Masking Bit for low TX Bias alarm channel 3		
		M-Tx3 Bias High Warning	Masking Bit for high TX Bias warning channel 3		
		M-Tx3 Bias Low	Masking Bit for low TX Bias		

		Warning	warning channel 3	
		M-Tx4 Bias High Alarm	Masking Bit for high TX Bias alarm channel 4	
		M-Tx4 Bias Low Alarm	Masking Bit for low TX Bias alarm channel 4	
		M-Tx4 Bias High Warning	Masking Bit for high TX Bias warning channel 4	
		M-Tx4 Bias Low Warning	Masking Bit for low TX Bias warning channel 4	
246-255	10	Reserved		00H

## Mechanical Specifications

