

BO-SFP+XX-80 Series

10 Gigabit CWDM 80km SFP+ Transceiver
RoHS 6 Compliant

Models:

BO-SFP+C47-80

BO-SFP+C49-80

BO-SFP+C51-80

BO-SFP+C53-80

BO-SFP+C55-80

BO-SFP+C57-80

BO-SFP+C59-80

BO-SFP+C61-80



Features

- ◆ Up to 11.3 Gb/s bi-directional data links
- ◆ Compliant with 10GBASE-ZR
- ◆ Compliant with 10GFC
- ◆ Compliant with SFF-8431
- ◆ Hot-pluggable SFP+ footprint
- ◆ Temperature-stabilized EML laser
- ◆ Duplex LC connector
- ◆ Built-in digital diagnostic functions
- ◆ Up to 80km on SMF
- ◆ Single power supply 3.3V
- ◆ RoHS Compliance
- ◆ Operating temperature range: 0°C to 70°C.

Applications

- ◆ CWDM 10G Ethernet
- ◆ CWDM 10G Fiber Channel

Ordering information

Part No.	Data Rate	Connector	Temp.	Distance	CDR	DDMI
BO-SFP+XX-80*	Up to 11.3Gbps	LC	Standard	80km	Yes	YES

*Standard version

Product Description

The BO-SFP+XX-80 series optical transceivers are based on 10G Ethernet and SFF-8431 standard, and provide a quick and reliable interface for the 10G CWDM application. The digital diagnostics functions are available via the 2-wire serial bus specified in the SFF-8472..

General Specifications

Parameter	Symbol	Min	Typ	Max	Unit	Remarks
Data Rate	DR	1.2		11.3	Gb/s	1
Bit Error Rate	BER			10–12		
Operating Temperature	TOP	0		70	°C	2
Storage Temperature	TSTO	– 40		85	°C	3
Supply Current	IS		450	500	mA	4
Input Voltage	VCC	3.14	3.3	3.46	V	
Maximum Voltage	VMAX	– 0.5		4	V	4

Notes:

1. IEEE 802.3ae
2. Case temperature
3. Ambient temperature
4. For electrical power interface

Link Distances

Parameter	Fiber Type	Distance Range (km)
1.2 – 11.3 Gb/s	9/125um SMF	80

Optical Characteristics – Transmitter

VCC=3V to 3.6V, TC=0°C to 70°C

Parameter	Symbol	Min	Typ	Max	Unit	Remarks
Optical Center Wavelength – 1470nm	λ_C	1465	1471	1477	nm	
Optical Center Wavelength – 1490nm	λ_C	1485	1491	1497	nm	
Optical Center Wavelength – 1510nm	λ_C	1505	1511	1517	nm	
Optical Center Wavelength – 1530nm	λ_C	1525	1531	1537	nm	
Optical Center Wavelength – 1550nm	λ_C	1545	1551	1557	nm	
Optical Center Wavelength – 1570nm	λ_C	1565	1571	1577	nm	
Optical Center Wavelength – 1590nm	λ_C	1585	1591	1597	nm	
Optical Center Wavelength – 1610nm	λ_C	1605	1611	1617	nm	
Optical Power	POUT	0		4	dBm	1
Extinction Ratio	ER	9			dB	
Spectral Width (– 20 dB)	$\Delta\lambda$			0.6	nm	
Side Mode Suppression Ratio	SMSR	30			dB	

Parameter	Symbol	Min	Typ	Max	Unit	Remarks
Relative Intensity Noise	RIN			- 128	dB/Hz	
Transmitter Dispersion Penalty	TDP			3.2	dB	
Transmitter Jitter						2
Launch Power of OFF Transmitter	POUT_OFF			- 30	dBm	1

Notes:

1. Average
2. According to IEEE 802.3ae requirement

Electrical Characteristics – Transmitter

V_{CC}=3.14V to 3.46V, T_C=0°C to 70°C

Parameter	Symbol	Min	Typ	Max	Unit	Remarks
Input differential impedance	RIN		100		Ω	
Differential data input swing	VIN_PP	120		850	mV	
Transmit disable voltage	VD	2		VCC	V	
Transmit enable voltage	VEN	VEE		VEE+0.8	V	

Electrical Characteristics – Receiver

V_{CC}=3.14V to 3.46V, T_C=0°C to 70°C

Parameter	Symbol	Min	Typ	Max	Unit	Remarks
Differential data output swing	VOUT_PP	300		850	mV	
Data output rise time (20%-80%)	TR		30		ps	
Data output fall time (20%-80%)	TF		30		ps	
LOS Fault	VLOS_Fault	2		VCC_HOST	V	
LOS Normal	VLOS_Normal	VEE		VEE+0.5	V	

Digital Diagnostic Functions

SFP10-CWDM-ZR-xxxx- supports the 2-wire serial communication protocol as defined in the SFF 8472. Digital diagnostic information is accessible over the 2-wire interface at the address 0xA2. Digital diagnostics for SFP10-CWDM-ZR-xxxx- are internally calibrated by default. A micro controller unit inside the transceiver gathers the monitoring information and reports the status of transceiver.

Transceiver Temperature, internally measured, represented as a 16 bit signed twos complement value in increments of 1/256 degrees Celsius, Temperature accuracy is better than ±3 degrees Celsius over specified operating temperature and voltage.

Transceiver Supply Power, internally measured, represented as a 16 bit unsigned integer with the voltage defined as the full 16 bit value (0 – 65535) with LSB equal to 100 μVolt, yielding a total range of 0 to +6.55 Volts.

Transceiver TX bias current, internally measured, represented as a 16 bit unsigned integer with the current defined as the full 16 bit value (0 – 65535) with LSB equal to 2 μ A, yielding a total range of 0 to 131mA. Accuracy is better than \pm 10% over specified operating temperature and voltage.

Transceiver TX output power, internally measured, represented as a 16 bit unsigned integer with the power defined as the full 16 bit value (0 – 65535) with LSB equal to 0.1 μ W. Data is assumed to be based on measurement of laser monitor photodiode current. Accuracy is better than \pm 3dB over specified temperature and voltage. Data is not valid when the transmitter is disabled.

Transceiver RX received optical power, internally measured, represented as a 16 bit unsigned integer with the power defined as the full 16 bit 35 value (0 – 65535) with LSB equal to 0.1 μ W. Accuracy is better than \pm 3dB over specified temperature and voltage.

Block Diagram of Transceiver

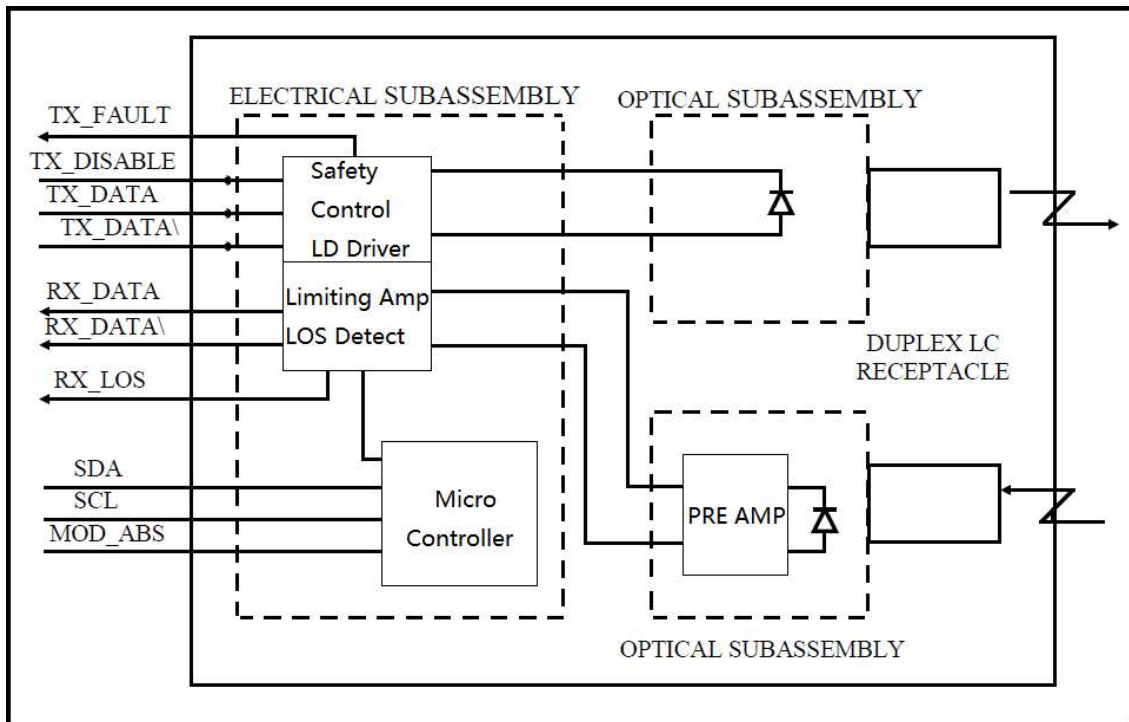

Transmitter Section

The Laser driver accept differential input data and provide bias and modulation currents for driving a laser. An automatic power-control (APC) feedback loop is incorporated to maintain a constant average optical power. CWDM DFB in an eye safe optical subassembly (OSA) mates to the fiber cable.

TX_DISABLE

The TX_DISABLE signal is high (TTL logic “1”) to turn off the laser output. The laser will turn on within 1ms when TX_DISABLE is low (TTL logic “0”).When the TX_FAULT signal is high, output indicates a laser fault of some kind. Low indicates normal operation.

Receiver Section

The receiver utilizes a PIN detector integrated with a trans-impedance preamplifier in an OSA. This OSA is connected to a Limiting Amplifier which providing post-amplification quantization, and optical signal detection. The limiting Amplifier is AC-coupled to the transimpedance amplifier, with internal 100Ω differential termination.

Receive Loss (RX_LOS)

The RX_LOS is high (logic “1”) when there is no incoming light from the companion transceiver. This signal is normally used by the system for the diagnostic purpose. The signal is operated in TTL level.

Controller Section

The micro controller unit monitors the operation information of LD driver and Limiting Amplifier. And report these status to the customer.

Electrical Pad Layout

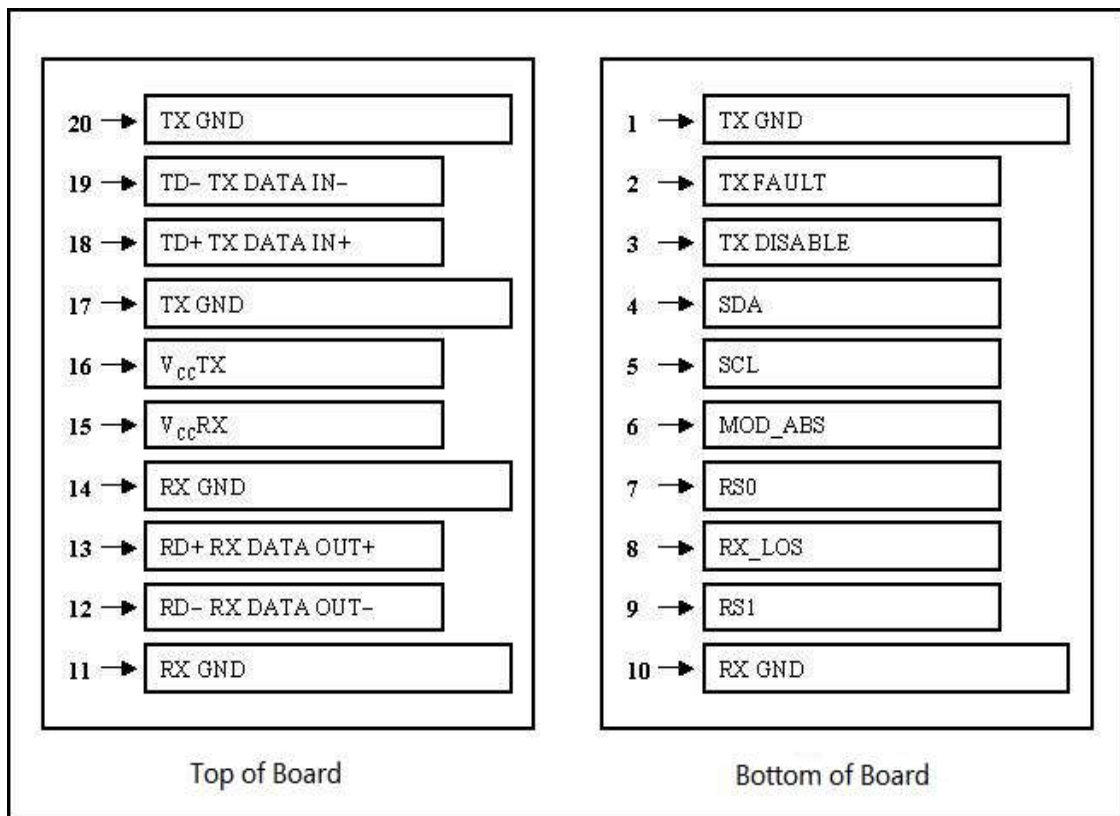
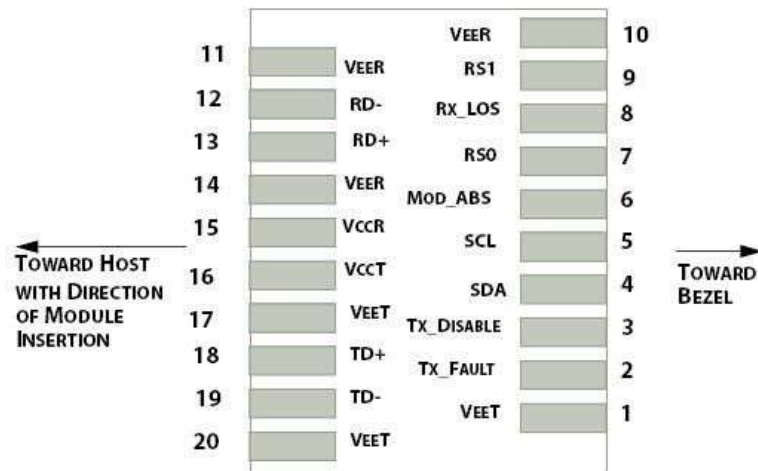

Pin Assignment

PIN #	Symbol	Description	Remarks
1	VEET	Transmitter ground (common with receiver ground)	1
2	TFAULT	Transmitter Fault.	
3	TDIS	Transmitter Disable. Laser output disabled on high or open	2
4	SDA	Data line for serial ID	3
5	SCL	Clock line for serial ID	3
6	MOD_ABS	Module Absent. Grounded within the module	3
7	RS0	No connection required	
8	LOS	Loss of Signal indication. Logic 0 indicates normal operation	4
9	RS1	No connection required	1
10	VEER	Receiver ground (common with transmitter ground)	1
11	VEER	Receiver ground (common with transmitter ground)	1
12	RD-	Receiver Inverted DATA out. AC coupled	
13	RD+	Receiver Non-inverted DATA out. AC coupled	
14	VEER	Receiver ground (common with transmitter ground)	1
15	VCCR	Receiver power supply	
16	VCCT	Transmitter power supply	
17	VEET	Transmitter ground (common with receiver ground)	1
18	TD+	Transmitter Non-Inverted DATA in. AC coupled	
19	TD-	Transmitter Inverted DATA in. AC coupled	
20	VEET	Transmitter ground (common with receiver ground)	1

Notes:

1. Circuit ground is isolated from chassis ground
2. Disabled: TDIS>2V or open, Enabled: TDIS<0.8V
3. Should Be pulled up with 4.7k – 10k ohm on host board to a voltage between 2V and 3.6V
4. LOS is open collector output

References

1. IEEE standard 802.3ae. IEEE Standard Department, 2005.
2. Enhanced 8.5 and 10 Gigabit Small Form Factor Pluggable Module “SFP+” – SFF-8431
3. Digital Diagnostics Monitoring Interface for Optical Transceivers – SFF-8472.

Mechanical Specifications

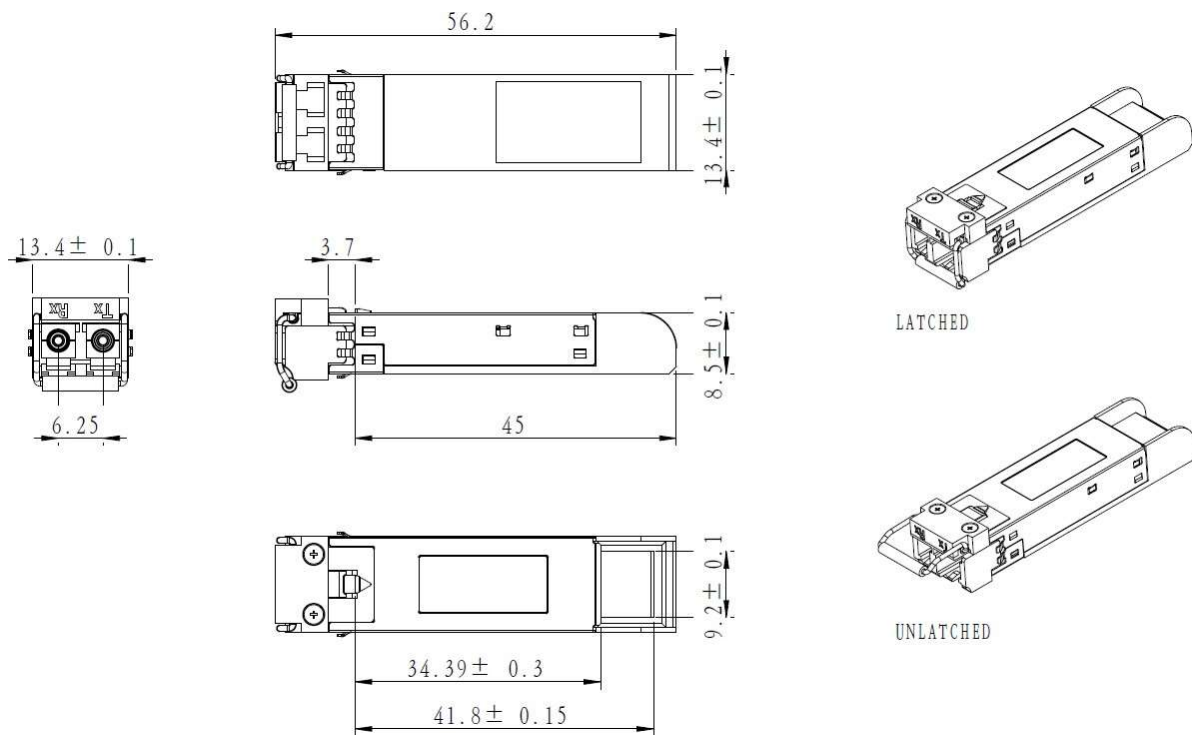

ALL DIMENSIONS ARE ±0.2mm UNLESS OTHERWISE SPECIFIED UNIT: mm

CONTACTS:

Address: 12A, Krasnolesya Street, Yekaterinburg, Russia

Tel: +7(343) 379-98-38

Fax: +7(343) 379-98-38

E-mail: info@nag.ru

Online shop: <http://shop.nag.ru>