

TEC Thermoelectric Cooler USER MANUAL

MODEL: SNR-ACC-300-TEC

※ please read this manual book before use

1. Product Introduction

1.1. Introduction

The thermoelectric cooler (short name of "TEC"), made of semiconductor refrigeration piece, heat sinks, fans and panel, is a kind of cooling equipment consists of Peltier material. The inner sealed circuit is composed of the two different metal leads, X and Y. When it is on power, heat on cool end is transferred to hot end, which leads to the temperature drop at cool end and temperature rise at hot end. The switch between hot end and cool end can be completed by changing electrode.

1.2. Working principle

When the DC flow through the circuit, which is formed by different conductor connection in nodes produces endothermic or exothermic phenomenon, this phenomenon called peltier effect. TEC use in this peltier effect. When TEC power on, one side cooling through the fan and the heat sink to absorb heat, contained in the other side of the heating through the fan and heat sink get heat away.

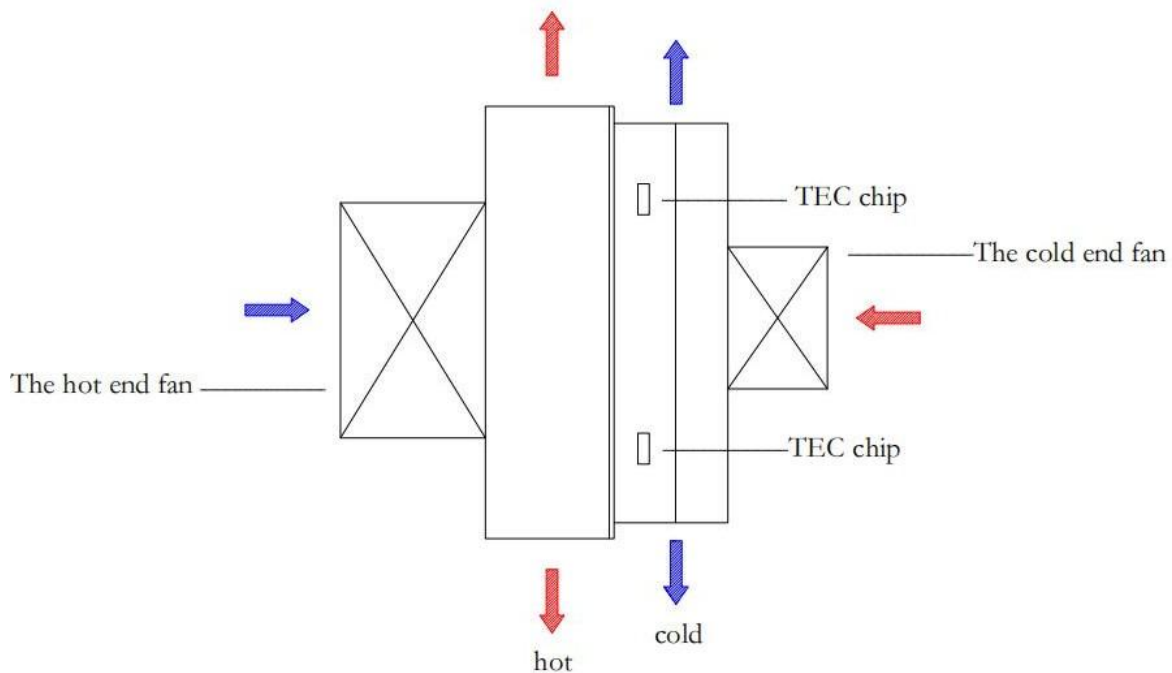

Working principle

2. Product parameters

2.1. Product technical parameters

Dc voltage	VDC	-58 - -44
power	W	403
Cooling capacity	W	300
Heating capacity	W	350
installation	/	Door
Working temperature range	°C	-40 - +55
Ambient humidity	RH	5% - 95%
Protection grade	/	IP 55
Noise (dB)	dB(A)	66
weight	Kg	8

FEATURES :

- Using semiconductor electronic cooling, small volume, light weight.
- No compressor, no Freon, no pollution, no vibration, no leak.
- Free mounting, applicable to a variety of places.
- Working ambient temperature: $-10^{\circ}\text{C} \sim +70^{\circ}\text{C}$
- Welded fin-heat sink, high efficiency heat.
- High-dense foam insulation between heat sink and cold heat sink.
- Hot-side heat sink overheat protection temperature setting $+75^{\circ}\text{C} \pm 5^{\circ}\text{C}$
- It can be remote monitored through RS485.

2.3. Size of product

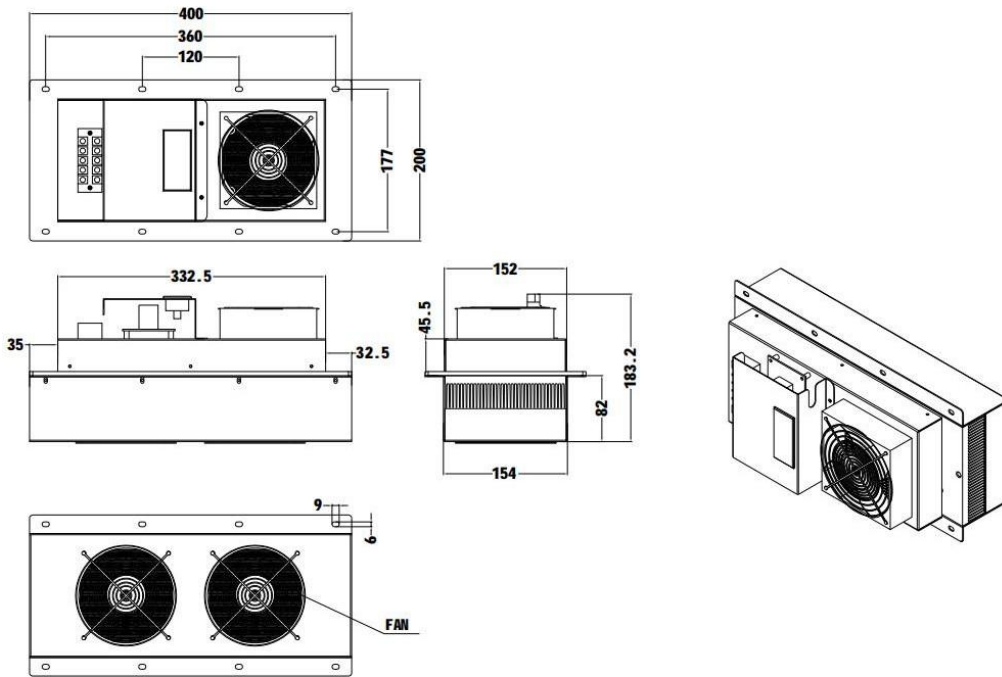

3. Installation Instruction

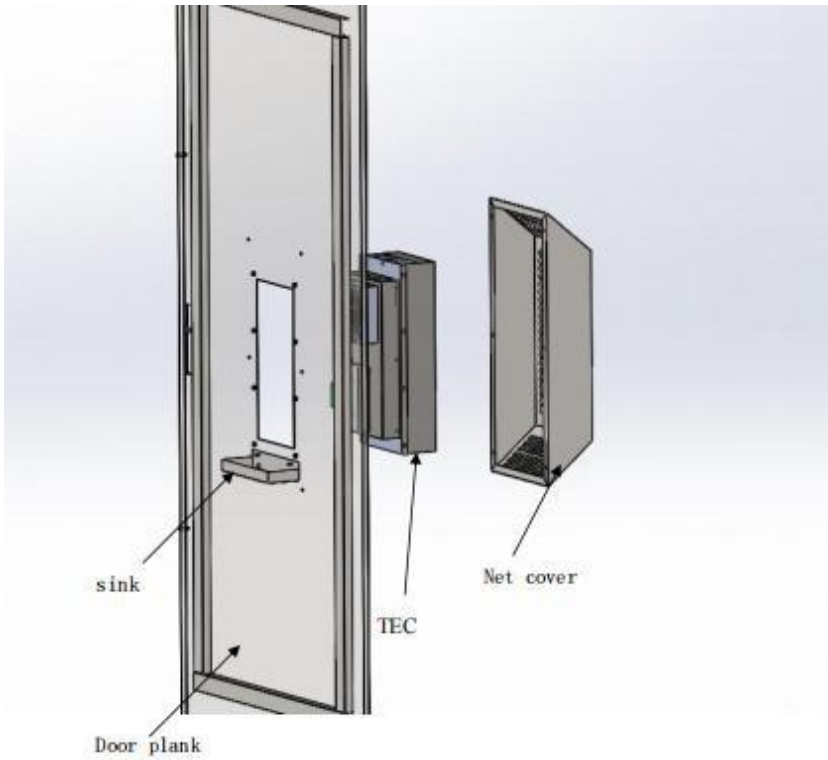

4. Power input



1	2	3	4	5
+	-	NC	COM	NO
DC48V		Alarm		

+ ::DC 48V +

- : DC 48V -

NO : Normally open (Connect at the alarm)

NC : Normally closed (Disconnect when warning)

COM : Communication point

5. Products running

5.1. Product check before operation

After install ,please check one by one;

It's the below side that have control panel and connect well with the cabinet , well seal;

Power voltage and working voltage are consistent;

The line must be connected well and consistent with manual book;

Inner and outer loops and into the outlet without stop;

Inside and outside the fan rotation freely.

5.2. Products running

Turn on the power, TEC start to self-inspection. Then TEC Through temperature detection inside the cabinets ,According to control the operation of the logic control TEC air conditioning.

5.3. Monitor

TEC connect with computer though RS485, user can check system state by monitor background (including fan , TEC , sensor) and change parameter.

6. Parameter Setting and error code

6.1. Parameter Setting

On the main window, you can enter parameter setting menu by pressing 'M' key for 5 seconds, the ▲ and ▼ keys can change the function code. Pressing "S" key, It will display the parameter value, the value can be modified through the ▲ and ▼ keys(long press can quickly change the value), Pressing M key can return to function list, press the SET key will modify the parameters, modify the system displays after the success of End, and then return to the display function code , press the M key for 3 seconds to exit the parameter setting interface , return to the main screen. Set the code below:







Code	Parameter	Range	Default	Note
F01	TE cooling start temperature	22~50	30℃	
F02	TE cooling return difference temperature	2~15	6℃	
F03	TE heating start temperature	-40~20	5℃	
F04	TE heating return difference temperature	2~15	10℃	
F05	TE work mode when temperature fail	0~1	1	
F06	Hydrogen discharging interval time	5~30	6Hour	
F07	Hydrogen discharging work time	5~60	2Minute	
F08	TE low voltage	40~48	44V	
F09	TE high voltage	49~60	58V	
F10	Cabinet inside low temperature limit	-40~20	0℃	
F11	Cabinet inside high temperature limit	25~60	35℃	
F12	Device communication address	1~255	1	

6.2 Error Code

The controller will generate an alarm signal if the controller and the parts failed or the temperature is out of range. The alarm lamp on the panel is lit. LED will display the cabinet inside temperature and error code alternately. When the device has multiple alarms, the operator will alternately display the alarm codes. The indication of the error code as following :

Code	Indication	
E01	Cabinet inside temperature alarming	
E03	Cabinet inside low temperature alarming	
E04	Cabinet inside high temperature alarming	
E07	Internal fan speed abnormal alarming	
E08	External fan speed abnormal alarming	
E09	High TE current supply	
E10	Low TE current supply	
E11	High TE voltage supply	
E12	Low TE voltage supply	
E13	Gate intrude alarming	
E14	Water intrude alarming	
E15	Humidity alarming	
E16	Smog alarming	
E17	Bump alarming	

6.3. State Lights

Lamp	Indication	Lighten	Flash
	Temperature	Setting Parameter	Selt-Checking
	Cooling	Cooling State	--
	Heating	Heating State	---
	Fan	External Fan State	--
	Alarm	---	Alarm On

7. Maintenance

7.1. Regular inspection

- A. Inspect DC,alarm line ,connect line;
- B. Check whether the TEC operate normally;
- C. Check whether has block from outer circulating air inlet ;
- D. Suggested that regular inspection 4 times a year.

7.2. Keep

TEC are used in the outdoor environment for long-time,there will be dust on outer circulating air inlet type and extruded aluminum radiator , should clean and maintenance .

8. After-sales service and warranty

8.1. Warranty

The warranty period depends on the contract within normal use.

8.2. Free maintenance range

During warranty period, any problems caused by the product itself will be repaired for free. Customers are required to provide product model,but below disclaimer range:

Disclaimer range;

A. Cannot provide the product serial number (see nameplate attached to the product) ;

B. Damage caused by the user's replacing parts or disassembly, or damage caused for disassembly by non-authorized service;

C. Error not from TEC ,such as the fault from user's device, users of software ;

D. Physical damage caused during shipment, installation and other improper use (such as the air conditioner cannot be inverted etc.;

D. Not in accordance with the specification requirements for installation or maintenance or damage caused by force majeure.

8.3. Remark

If the user has other special requests, besides the items of this usage instruction, it should also include other items and notes listed in the signed technical agreement by both parties. If such usage instruction conflicts with signed technical agreement, the technical agreement shall prevail .

