

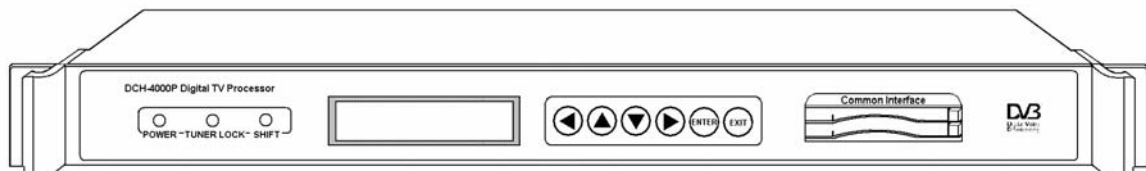


**PBI** Pro Broadband Inc.

# DCH-4000P Series

## Professional Digital Decoder

### User Manual



# Table of contents

1. SAFETY.....	1
2. TECHNICAL INTRODUCTION.....	2
2.1 Features.....	2
2.2 Factory Options .....	2
3. INSTALLATION.....	3
3.1 Inspection and Test.....	3
3.2 Functional Self Test .....	4
3.3 Mounting .....	4
4. FRONT PANEL.....	4
4.1 Front Panel List.....	4
4.2 Indicator LEDs .....	4
4.3 Liquid Crystal Display .....	5
4.4 Keypad.....	5
4.5 Common Interface .....	5
5. REAR PANEL .....	6
5.1 Power Supply.....	6
5.2 Output Connectors.....	6
5.3 ASI Input Connector.....	7
5.4 RS-232 Interface.....	7
5.5 Ethernet Interface .....	7
5.6 TS/IP Interface (Factory Optional).....	7
6. INSTALLATION.....	7
6.1 Main Menu .....	7
6.2 System Menu .....	8
6.2.1 Local Setup .....	8
6.2.2 Setting up the Trap IP Address .....	8
6.2.3 Editing the Unit Name .....	9
6.2.4 Checking the Properties .....	9
6.2.5 Recover Factory Default Settings .....	9
6.2.6 Setting Machine Type .....	9
7. Manual for DCH-4000P-30S /-30T/-30C/-30S2 .....	9
7.1 Menu Structure for DCH-4000P-30S /-30T/-30C/-30S2.....	9

7.2 Setting Inputs for DCH-4000P-30S /-30T/-30C/-30S2 .....	11
7.2.1 Checking Status of Inputs .....	11
7.2.2 Setting the Tuner Parameters .....	11
7.3 Setting Outputs for DCH-4000P-30S /-30T/-30C/-30S2 .....	13
7.3.1 Checking Status of Outputs .....	13
7.3.2 Setting Common Interface .....	14
7.3.3 Setting the Parameters of Decoder .....	14
7.3.4. Setting the ASI1 Output .....	15
7.3.5. Setting the ASI2/SDI Output .....	15
7.3.6. Setting the Mux/Filter .....	15
8. Manual for DCH-4000P-41S /-41T/-41C/-41S2 .....	15
8.1 Menu Structure for DCH-4000P-41S /-41T/-41C/-41S2 .....	15
8.2 Setting Inputs for DCH-4000P-41S /-41T/-41C/-41S2 .....	18
8.2.1 Checking Status of Inputs .....	18
8.2.2 Setting the Tuner Parameters .....	18
8.2.3 Setting the Ethernet Connector .....	18
8.3 Setting Outputs for DCH-4000P-41S /-41T/-41C/-41S2 .....	19
9. Manual for DCH-4000P-42S /-42T/-42C/-42S2 .....	19
9.1 Menu Structure for DCH-4000P-42S /-42T/-42C/-42S2 .....	19
9.2 Setting Inputs for DCH-4000P-42S /-42T/-42C/-42S2 .....	21
9.3 Setting Outputs for DCH-4000P-42S /-42T/-42C/-42S2 .....	22
9.3.1 Setting the Ethernet TS over IP output .....	23
9.3.2 Other output settings for DCH-4000P-42S /-42T/-42C/-42S2 .....	23
10. REMOTE MONITORING AND CONTROL .....	23
10.1 Install HDMS to a PC .....	23
10.2 Connect to HDMS .....	23
10.3 Login to HDMS .....	24
10.4 Add DCH-4000P-xx to HMDS .....	24
10.5 DCH-4000P-xx in HDMS .....	24
10.6 Other Settings .....	25
11. FAQ .....	25
12. Appendix .....	25
12.1 Specification .....	25

## 1. SAFETY

***Please read this chapter before installation and use of the device***

This equipment is provided with a protective earthing ground incorporated in the power cord. The main plug shall only be inserted in a socket outlet provided with a protective earth contact. Any interruption of the protective conductor, inside or outside the device, is likely to make the device dangerous.

The device described in this manual is designed to be used by properly-trained personnel only. Adjustment, maintenance and repair of the device shall be carried out by qualified personnel.

No operator serviceable parts inside. Refer servicing to qualified personnel. To prevent electrical shock, do not remove covers.

For the correct and safe use of the device, it is essential that both operating and servicing personnel follow generally accepted safety procedures in addition to the safety precautions specified in this manual.

Whenever it is likely that safety protection is impaired, the device must be made in-operative and secured against unintended operation. The appropriate servicing authority must be informed. For example, safety is likely to be impaired if the device fails to perform the intended measurements or shows visible damage.

### WARNINGS

- Do not use the equipment in moisture environment surroundings.  
Avoid direct contact with water.
- Never place the equipment in direct sunlight.
- The outside of the equipment may be cleaned using a lightly dampened cloth. Do not use any cleaning liquids containing alcohol, methylated spirit or ammonia etc.
- For continued protection against fire hazard, replace line fused only with same type.

## 2. TECHNICAL INTRODUCTION

DCH-4000P-xx is a professional IRD with a variety of input (including DVB over ASI, IP, QPSK, QAM, COFDM and DS3) and output (CVBS, SDI, ASI, DS3 and IP) combinations. An appropriate IP port equipped as an option supports DVB over IP applications. LAN control and monitoring are achieved with TCP/IP, SNMP and HDMS\*.

(\*Headend Devices Management System, a remote management software)

### 2.1 Features

- Fully complies with MPEG-2, MP@ML and DVB-S/-T/-C standards
- IP input or output with UDP/RTP (optional)
- Multicast and Unicast on IP
- Supports PAL, NTSC or SECAM
- Supports various Conditional Access systems
- SDI video output with digital audio embedded
- Two sets of independent ASI outputs
- Automatic PMT update
- Compatible with Multiple De-encrypt CI modules
- DS3 I/O for TS (optional)
- Switchable audio sound track
- Teletext VBI, EBU subtitle and DVB subtitle
- Upgradeable through LAN
- Easy-to-use LCD menu

### 2.2 Factory Options

Function	Model No.	DCH-4000P-30				DCH-4000P-41				DCH-4000P-42			
		-S	-C	-T	-S2	-S	-C	-T	-S2	-S	-C	-T	-S2
IP Output (TS)										■	■	■	■
IP Input (TS)						■	■	■	■				
DVB-S Input		■				■				■			
DVB-S2 Input					■				■				■
DVB-C Input			■				■				■		
DVB-T Input				■				■				■	
PCMCIA Slot								■					
ASI TS Input/Output								■					
Audio Embedded SDI Output								■					
Ethernet Remote Control								■					
BNC Video Output								■					
AV Output								■					
Balance XRL Audio Output								■					
Simulcrypt Compliant								■					
Standard								■					

*Figure 2.1 Factory Option list of DCH-4000P series*

### 3. INSTALLATION

**Warning:**

This equipment is provided with a protective earthing ground incorporated in the power cord. The main plug shall only be inserted in a socket outlet provided with a protective earth contact. Any interruption of the protective conductor, inside or outside the instrument, is likely to make the instrument dangerous. The type of main plugged shipped with each instrument depends on the country of application.

**Caution:**

Do not connect AC power until you have verified that the line voltage is correct and the proper fuses are installed. The equipment requires a power source of either 50/60 Hz at 110V or 50/60 Hz at 240V. The voltage ranges for these nominal voltage values are shown in the table:

POWER REQUIREMENT	
Input voltage	90-260 Vrms auto select
Frequency	47 to 63 Hz
Power	50 VA max. / 30 VA typical.
Current	110 V/0.27A or 240 V/0.125A typical

**Caution:**

Be sure the supply voltage is within the specified range.

**Checking the fuses:**

The recognized recommended fuses are size 5 by 20 mm, rate T 2.0A, 250 V (UL and IEC approved).

The line fuse is housed in a small container besides the power connector on the rear panel. To check the fuse, insert the tip of a screwdriver in the slot at the middle of the container and pry gently to extend the fuse where there is a little tap and pull out the fuse gently. The fuse is attached to the line module and cannot be removed.

#### 3.1 Inspection and Test

Check if the device has any visible damage. If everything seems all right, power can be applied to the device. The main socket and fuse are located at the rear panel of the device.

When the device is turned on, verify that the display shows the following message:

DCH-4000P                      (factory default unit-name)

IP: 168.192.1.21              (factory default IP Address)

If no message is shown in the display or there is not light in the display, the device is

defective and has to be returned for servicing.

### 3.2 Functional Self Test

No specific functional self test is needed.

The device has been factory tested according to recognized test procedures and is ready for operation.

### 3.3 Mounting

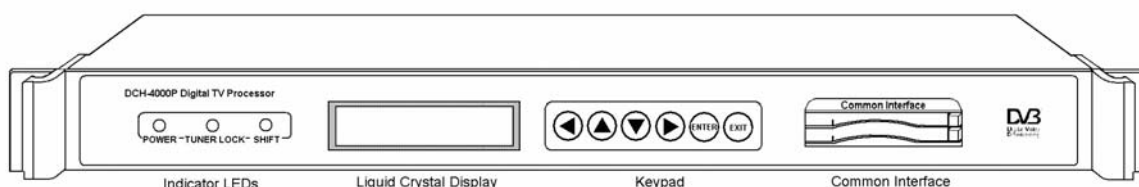
The environment should be relatively dust free, free of excessive vibration and the ambient temperature between 0 °C to 40 °C. Relative humidity of 20% to 80% (non-condensed) is recommended.

Air intake for cooling is achieved via holes at the side of the device and the fans inside. The air flow should not be obstructed. Therefore, the device has to be placed on a flat surface, leaving some space at the sides of the device.

When in operation, the internal temperature should not exceed the limit of 70 °C.

## 4. FRONT PANEL

### 4.1 Front Panel List



*Figure 4.1 Front Panel of DCH-4000P-xx Series Receiver*

### 4.2 Indicator LEDs

There are 3 LED-indicators:

**-POWER:** the status of the power supply

green: the power is turned on

off : the power is turned off

**-TUNER LOCK:** the status of the tuner

green: The incoming QPSK is locked by the tuner.

off : there is no QPSK input signal or the signal is unlocked

**-ALARM:** the status of input signal source, which includes IP input, QPSK signal input and DVB-ASI TS input.

### 4.3 Liquid Crystal Display

The 2 x 20 character Liquid Crystal Display (LCD) shows all the required information about the selected parameters.

The top row of the LCD shows the selected parameter. The bottom row indicates the present values and how these can be adjusted.

The parameters are grouped in three menus:

- the **Inputs**, which gives the full operation on inputs parameters
- the **Outputs**, with the full operation control functions on outputs parameters
- the **Systems**, gives the general device management parameters and informs about the device working status

### 4.4 Keypad



*Figure 4.2 Keypad of DCH-4000P-xx series*

The 6 keys on the front panel allow you to navigate in the information given on the LCD and to change parameters, when the device operates under local control.

The **<ENTER>-key** is used to enter the main menu or a sub-menu. When you stand on the preferred menu, **<ENTER>** is used to activate the parameter on the bottom line and allows you to change the value. It also finishes the input of new alphanumeric values and confirms the changes.

The **<▲>-and<▼>-keys** are used to select between the main menus or sub-menus. When you stand on the preferred menu and the parameter is active, they are also used to change the numerical values. Selecting a digit with the **<◀>-and <▶>-keys**.

The **<EXIT>-key**, is used to exit a menu without any action.

### 4.5 Common Interface

There are two Common Interface slots. You can insert up to two different CAM modules for descrambling.



## 5. REAR PANEL

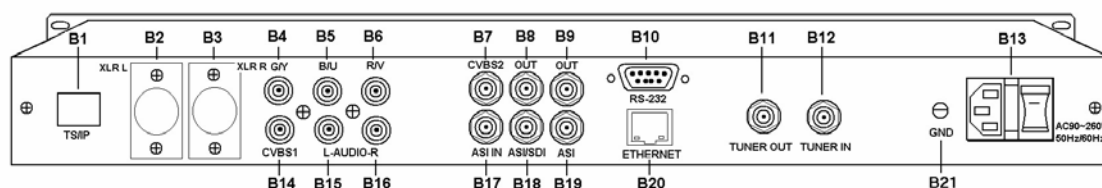


Figure 3.2 Rear Panel of DCH-4000P-xx Series

B1	TS/IP Input/Output interface
B2	XRL L interface
B3	XRL R interface
B4	RGB/YUV interface (G/Y)
B5	RGB/YUV interface (B/U)
B6	RGB/YUV interface (R/Y)
B7	CVBS2 Output interface
B8, B18	ASI2/SDI output interface
B9, B19	ASI1 output interface
B17	ASI input interface
B10	RS-232 interface
B11	Tuner Loop Out interface
B12	Tuner In interface
B13	Power socket, AC 90~260V
B14	CVBS1 Output interface
B15, B16	L-Audio-R interface
B20	Ethernet interface for remote management system
B21	Grounding

### 5.1 Power Supply

The power cord is inserted to an IEC main socket at the side of the device.

Check that the power cord is suitable for the country where the device will be used.

A standard power cord with a European DIN 49441 two pin main plug is delivered together with the device.

The line fuses are housed in a small container at the side of the power supply connector.

### 5.2 Output Connectors

The ASI interface B9), B19) and ASI2 interface B8), B18) are two pairs of independent ASI output. Both use female BNC connectors, with 75 Ohm impedance. The ASI interface B18) and B19) are used as a redundant output of B8) and B9) out.

Team-up with **PBI**, Brighten Your Digital View !

**Note:** the B8), B18) interface could be configured as SDI with Audio embedded. Please refer to **Chapter 7.3.5**.

### 5.3 ASI Input Connector

The ASI input B17) is a 75 ohm female BNC connector.

### 5.4 RS-232 Interface

This interface is a 9-pins female sub-D connector. The RS-232 interface is only used for factory software upgrade and configuration, so you are not allowed to connect any cable to the RS-232 connector, as that could damage the device.

### 5.5 Ethernet Interface

An RJ-45 connector B20) provides a remote control interface.

### 5.6 TS/IP Interface (Factory Optional)

An RJ-45 connector B1) provides a streaming stream over IP input or output.

## 6. INSTALLATION

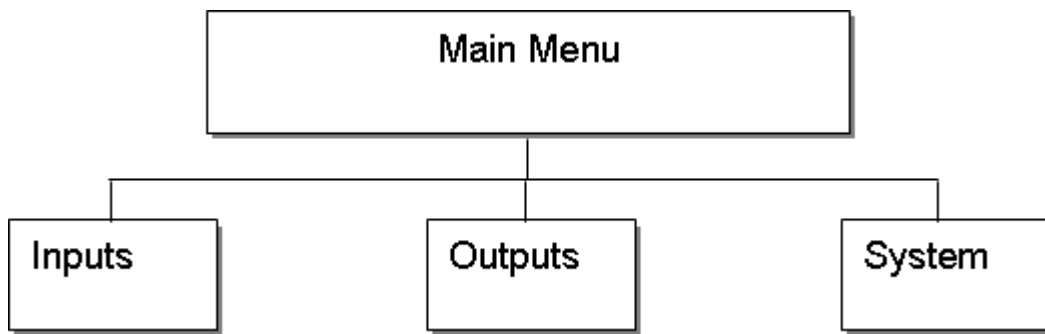
The device allows you to configure, control and monitor through the Keypad and front panel display when a remote control system is not used.

### 6.1 Main Menu

Turn on the device and wait for 8 to 10 seconds, while the device will complete self inspection and configuration. The top row of the LCD shows the name of the device. The local IP address is displayed on the bottom row of the LCD.

**Note:** the local IP address can be changed in the System Menu.

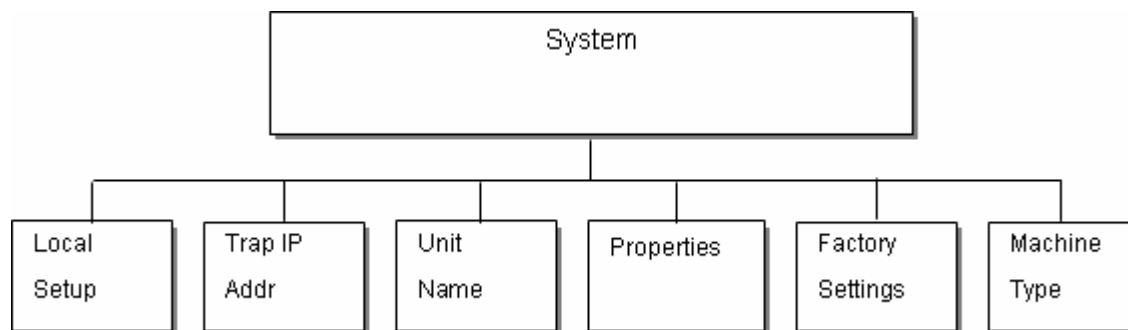
Use the **<ENTER>-key** to enter on the Main Menu. The **<▲>-and<▼>-keys** are used to choose between the three main menus.



*Figure 6.1 Main Menu*

## 6.2 System Menu

The system menu provides information about the general functions, the surroundings equipment and the hardware used.



*Figure 6.2 System Menu*

### 6.2.1 Local Setup

Each DCH-4000P-xx has an IP address, a network sub mask and a gateway. These must be set to an appropriate value for the network over which the unit can be accessed by the remote control system such as the HDMS.

**-IP Address:** The IP address for the unit.

**-Network Mask:** The network mask for the subnet to which the unit is connected.

**-Gateway:** The gateway for the network to which this unit is connected.

### 6.2.2 Setting up the Trap IP Address

The DCH-4000P-xx provides a Monitor Center IP address. You can set this to be the same IP address of the Monitor Center, which is typically a PC in order to allow the device to send messages to the monitor center. If the DCH-4000P-xx is connected with the HDMS remote management system, the Trap IP address is typically set to be the IP address of the PC on which the HDMS has been installed.

### 6.2.3 Editing the Unit Name

The DCH-4000P-xx allows you to edit the unit name which is displayed on the front panel LCD. The unit name should not be longer than 20 characters in ASCII format.

### 6.2.4 Checking the Properties

You are allowed to check the properties information of the device.

- **MAC address:** Factory-set MAC address which is guaranteed to be unique. You cannot configure this address.
- **FW Version:** the version of the FPGA software.
- **SW Version:** the version of the main software.

### 6.2.5 Recover Factory Default Settings

All the user configurable parameters will be set to the factory default settings, including IP address and the unit name. Note that the unit will not be connected with the HDMS remote management system until the IP is properly configured.

### 6.2.6 Setting Machine Type

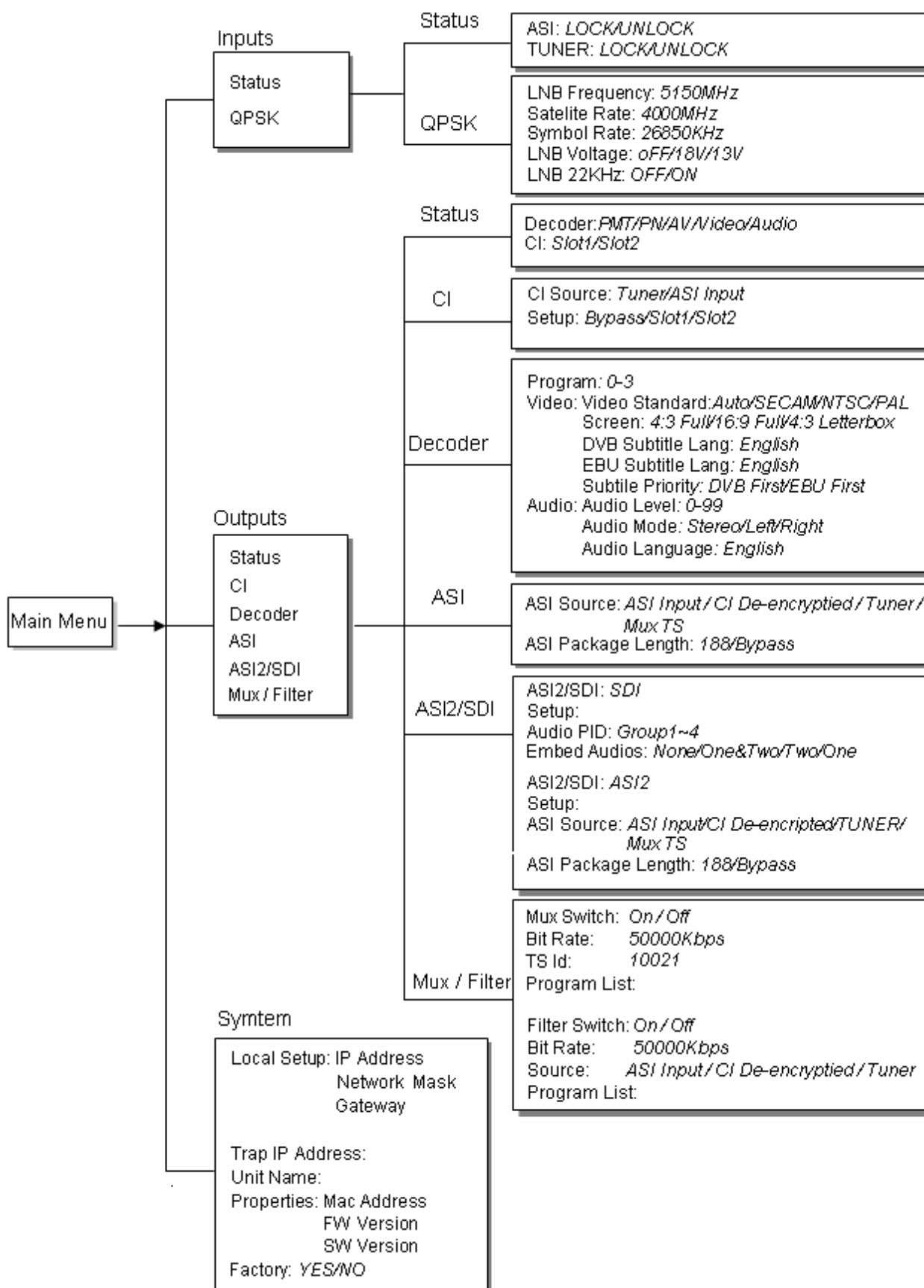
This setting is reserved for factory-setting, and you are not allowed to access this menu.

## 7. Manual for DCH-4000P-30S /-30T/-30C/-30S2

### 7.1 Menu Structure for DCH-4000P-30S /-30T/-30C/-30S2

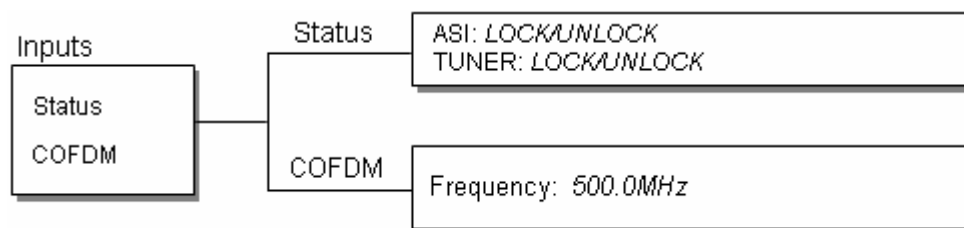
**Note:** only the Inputs menu differs from DCH-4000P-30S /-30T/-30C/-30S2 models.

## DCH-4000P-xx series Receivers

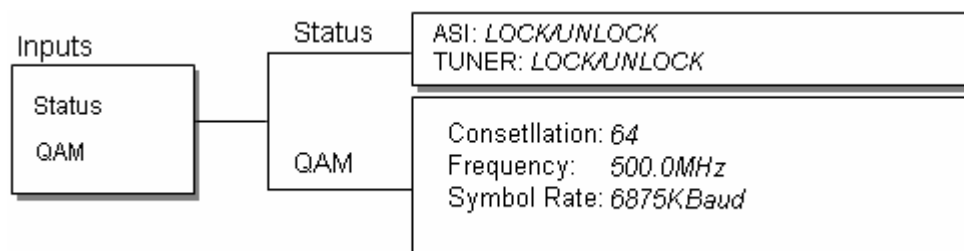


**Figure 7.1 Full Menu Structure for DCH-4000P-30S**

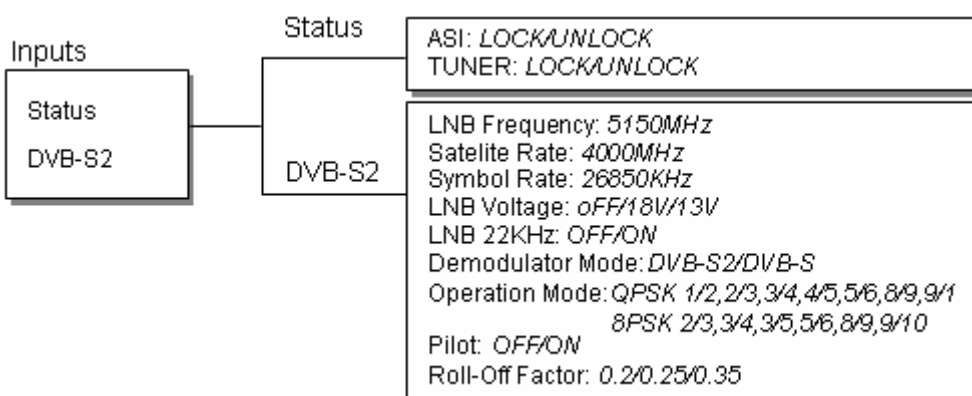
## DCH-4000P-xx series Receivers



**Figure 7.2** Inputs Menu Structure for DCH-4000P-30T



**Figure 7.3** Inputs Menu Structure for DCH-4000P-30C



**Figure 7.4** Inputs Menu Structure for DCH-4000P-30S2

## 7.2 Setting Inputs for DCH-4000P-30S /-30T/-30C/-30S2

Under Input Menu, you can monitor and configure the parameters of the Tuner.

### 7.2.1 Checking Status of Inputs

- **ASI Input:** locked or unlock indicate the status of the ASI input.
- **Tuner Input:** when the QPSK/QAM/COFDM signal is locked by the tuner, the bit rate is displayed on the bottom row of LCD.

### 7.2.2 Setting the Tuner Parameters

To receive the QPSK/QAM/COFDM signal, these parameters below must be set to appropriate values for the receiving antenna over which the device can receive the signal.

## DCH-4000P-xx series Receivers

---

### For QPSK Tuner:

- **LNB Local Oscillator (L.O.) Freq:** enter the frequency of the LNB in MHz.
- **Satellite Freq:** edit the satellite down link frequency in MHz. The IF frequency will be calculated automatically.
- **Symbol Rate:** enter the QPSK symbol rate.
- **LNB Voltage:** select the correct LNB voltage output of the F-connector: Off, 13 V, 18 V. <A>
- **LNB 22KHz:** activate the LNB 22 kHz control signal to the LNB: On or Off. <B>
- **Note:** please contact the local satellite operator for the satellite frequency and symbol rate.
  - <A> Normally, 13V switches the LNB to receive Vertical/Left hand polarization while 18V receive Horizontal/Right hand.
  - <B> Normally, 22KHz control signal switches the LNB to receive high band if any.

### For QAM Tuner:

- **Constellation:** enter the modulation mode of the QAM signal.
- **Frequency:** enter the frequency of the QAM signal in MHz.
- **Symbol Rate:** edit the symbol rate to the proper value in KBaud.

### For COFDM Tuner:

- **Frequency:** enter the proper frequency of the COFDM signal in MHz.

### For DVB-S2 Tuner:

- **LNB Local Oscillator (L.O.) Freq:** enter the frequency of LNB in MHz.
- **Satellite Freq:** edit the satellite down link frequency in MHz. The IF frequency will be calculated automatically.
- **Symbol Rate:** enter the QPSK/8PSK symbol rate.
- **LNB Voltage:** select the correct LNB voltage output of the F-connector: Off, 13 V, 18 V. <A>
- **LNB 22KHz:** activate the LNB 22 kHz control signal to the LNB: On or Off. <B>
- **Note:** please contact the local satellite operator for the satellite frequency and symbol rate.
  - <A> Normally, 13V switches the LNB to receive Vertical/Left hand polarization while 18V receive Horizontal/Right hand.
  - <B> Normally, 22KHz control signal switches the LNB to receive high band if any.
- **Demodulation Mode:** select the DVB-S or DVB-S2 demodulation mode.
- **Operation Mode:** select the appropriate operation mode in the menu. There are QPSK 1/2, 2/3, 3/4, 4/5, 5/6, 8/9, 9/10 and 8PSK 2/3, 3/4, 3/5, 5/6, 8/9, 9/10 to choose among.
- **Pilot:** select Off or On according to the actual signal.
- **Roll-Off Factor:** you can choose 0.2, 0.25 or 0.35.

## 7.3 Setting Outputs for DCH-4000P-30S /-30T/-30C/-30S2

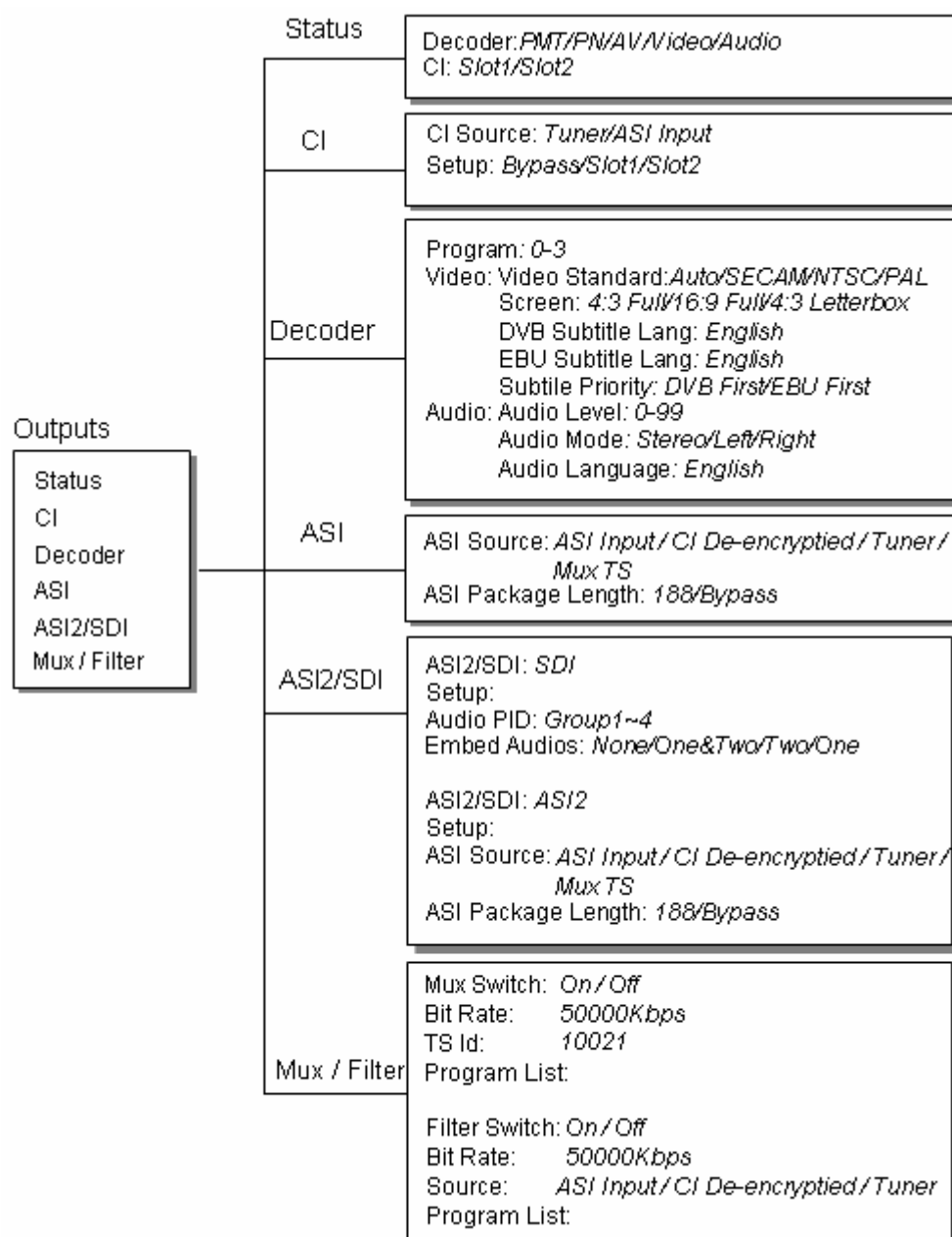


Figure 7.5 Outputs Menu Structure for DCH-4000P-30S /-30T/-30C/-30S2

### 7.3.1 Checking Status of Outputs

There are 2 displays on the LCD for monitoring the status of the decoder and the common interface.

- **Decoder:** OK or Alarms indicates the status of the decoder. You can use the <ENTER>-key to check detailed information in the submenu of the Decoder.
- **CI:** You can check the information of the CAM Modules in Slot1 and Slot2.



### 7.3.2 Setting Common Interface

There are 2 submenus: CI Source and Setup which allow you to set or select the parameters of the CI.

- **CI Source:** select Tuner or ASI input to set the signal source of descrambling.
- **Setup:** press the **<▲>** or **<▼>**-key to select the program which is expected to be descrambled, then press the **<ENTER>**-key to choose Slot1, or Slot2, or Bypass. Press the **<EXIT>**-key after configuration, and the following message will be shown on the LCD: "Confirm Changed? ENTER=YES, EXIT=NO". If you want to keep the changes, press the **<ENTER>**-key.
  - 0-xxxxx** displays the program name, which signal source is ASI.
  - 1-xxxxx** displays the program name, which signal source is TUNER.
  - 2-xxxxx** displays the program name, which signal source is TS/IP (this is invalid for 30 -10S/-11T/-12C/-13S2 series).
  - 3-xxxxx** factory occupied.

### 7.3.3 Setting the Parameters of Decoder

You can configure the parameters of Video and Audio of the program decoded by decoder.

- **Program:** Press the **<▲>** or **<▼>**-key to select the program which is expected to be decoded. Press the **<◀>**-and **<▶>**-key to choose channel from 0 to 3, then press the **<ENTER>**-key to confirm.
  - 0-xxxxx** displays the program name, which comes from ASI input.
  - 1-xxxxx** displays the program name, which comes from TUNER input.
  - 2-xxxxx** displays the program name, which comes from TS/IP input (this is invalid for 30 -10S/-11T/-12C/-13S2 series).
  - 3-xxxxx** displays the program name which comes from the CI.
- **Video:** You can configure the video parameters of programs in this submenu. Press the **<ENTER>**-key to confirm and press the **<EXIT>**-key to cancel.
  - Video Standard:** you can select Auto or SECAM or NTSC or PAL for the composite video output.
  - Screen:** select the screen mode: 4:3 Full, 16:9 Full or 4:3 Letterbox.
  - DVB Subtitle Lang:** select the language of DVB Subtitle.
  - EBU Subtitle Lang:** select the language of EBU Subtitle.
  - Subtitle Priority:** configure the priority of Subtitle; choose whether DVB or EBU should be first.
- **Audio:** You can configure the audio settings in the submenu.
  - Audio Level:** use the **<▲>** **<▼>** **<◀>** **<▶>**-keys to modify the audio level within this range: 0~99.
  - Audio Mode:** select Stereo, Left, Right or Mono for soundtracks.
  - Audio Language:** select the language of the audio.

### 7.3.4. Setting the ASI1 Output

User can configure the settings of ASI1 in this menu.

- **ASI Source:** select the signal source of ASI output: CI De-encrypted, TUNER, ASI Input or Mux-TS.
- **ASI Package Length:** you can configure the package length of ASI output as 188 bytes or select Bypass.

**Note:** the Mux-TS is only valid when the Mux or Filter is enabled and turned on. The Mux-TS indicates not only the after-multiplexed TS when Mux is enabled, but also the after-filtered TS when the filter is enabled.

### 7.3.5. Setting the ASI2/SDI Output

The ASI2/SDI port is user-configured as ASI output or SDI output.

If the port is configured as ASI2, the configuration method is the same as ASI. (Please refer to the **paragraph 7.3.4.**)

If the port is configured as SDI, there are two parameters which need to be set: Audio PID and Embed Audios.

- **Audio PID:** press the **<▲>** **<▼>**-keys to choose the audio PID from 1~4.
- **Embed Audios:** there are 4 options: none, one&two, two, and one.

### 7.3.6. Setting the Mux/Filter

**Note:** the Mux / Filter are alternative.

#### For Mux

**Mux Switch:** the internal multiplexer could be switched On/Off.

**Bit Rate:** set the output bit rate of the multiplexed TS in Kbps.

**TS ID:** you can configure the TS ID to mark the multiplexed TS.

**Program List:** the list of programs multiplexed. Press the **<ENTER>**-key to select the program which is expected to be multiplexed. A "\*" will be displayed in the front of the program name. Press the **<ENTER>**-key again to deselect a program.

#### For Filter

**Filter Switch:** the internal filter could be switched On/Off.

**Bit Rate:** set the output bit rate of the filtered TS in Kbps.

**Source:** select the source of the TS which is expected to be filtered.

**Program List:** the list of programs filtered. Press the **<ENTER>**-key to select the program which is expected to be filtered away. A "\*" will be displayed in the front of the program name. Press the **<ENTER>**-key again to deselect a program.

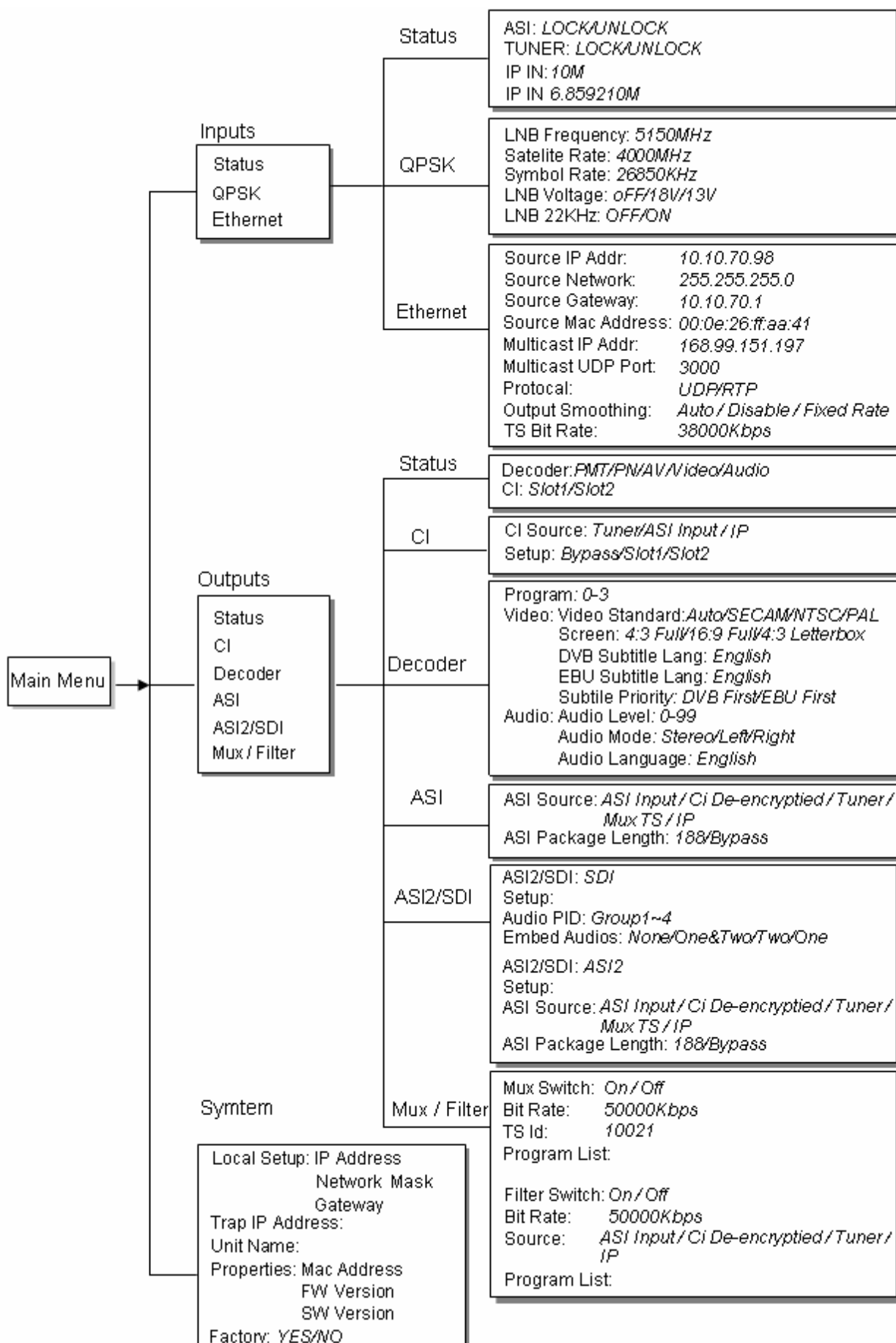
## 8. Manual for DCH-4000P-41S /-41T/-41C/-41S2

### 8.1 Menu Structure for DCH-4000P-41S /-41T/-41C/-41S2

**Note:** the Input menu differs from DCH-4000P-41S /-41T/-41C/-41S2 models according to the type of tuner.

Team-up with **PBI**, Brighten Your Digital View !

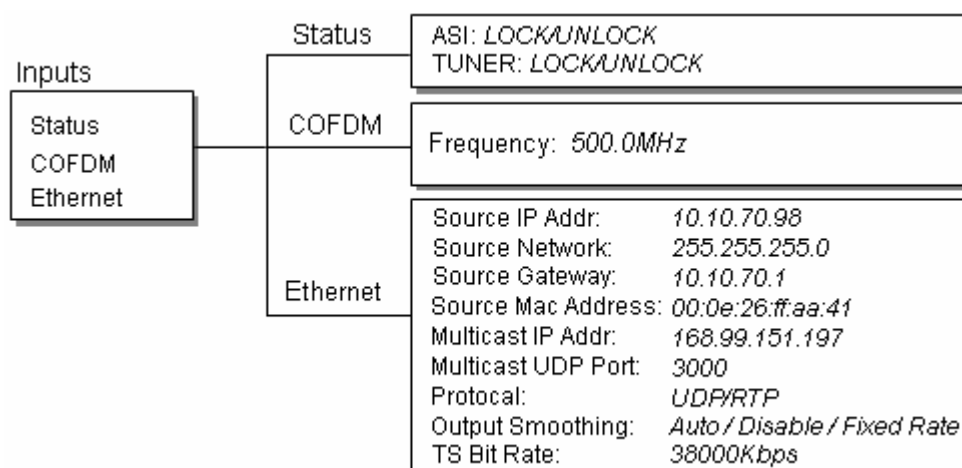
## DCH-4000P-xx series Receivers



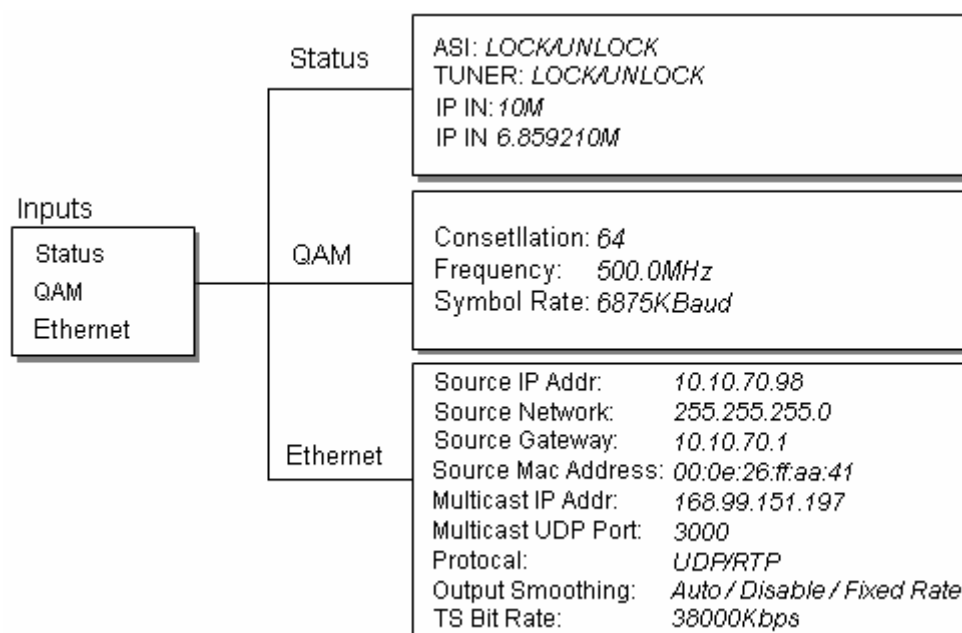
Team-up with **PBI**, Brighten Your Digital View !

## DCH-4000P-xx series Receivers

**Figure 8.1 Full Menu Structure for DCH-4000P-41S**



**Figure 8.2 Inputs Menu Structure for DCH-4000P-41T**



**Figure 8.3 Inputs Menu Structure for DCH-4000P-41C**



## DCH-4000P-xx series Receivers

---

- **Source Mac Address:** factory-set MAC addresses are guaranteed to be unique. Therefore you cannot configure the address.
- **Multicast IP Addr:** Enter the IP address of the multicast stream for the transport stream over IP.
- **Multicast UDP Port:** Enter the UDP port number of the TS over IP stream.
- **Protocol:** select the protocol for multicast: UDP or RTP.
- **Output Smoothing:** set the quality of TS which comes from the TS/IP input.
  - Auto: the bit rate is variable.
  - Disable: the unit let the TS pass by.
  - Fixed Rate: the bitrate is fixed.
- **TS Bit Rate:** set the bit rate of the TS comes from the TS/IP input. The setting is only valid when the output smoothing is configured as Fixed Rate.

### 8.3 Setting Outputs for DCH-4000P-41S /-41T/-41C/-41S2

Please refer to **paragraph 7.3** for the setting method.

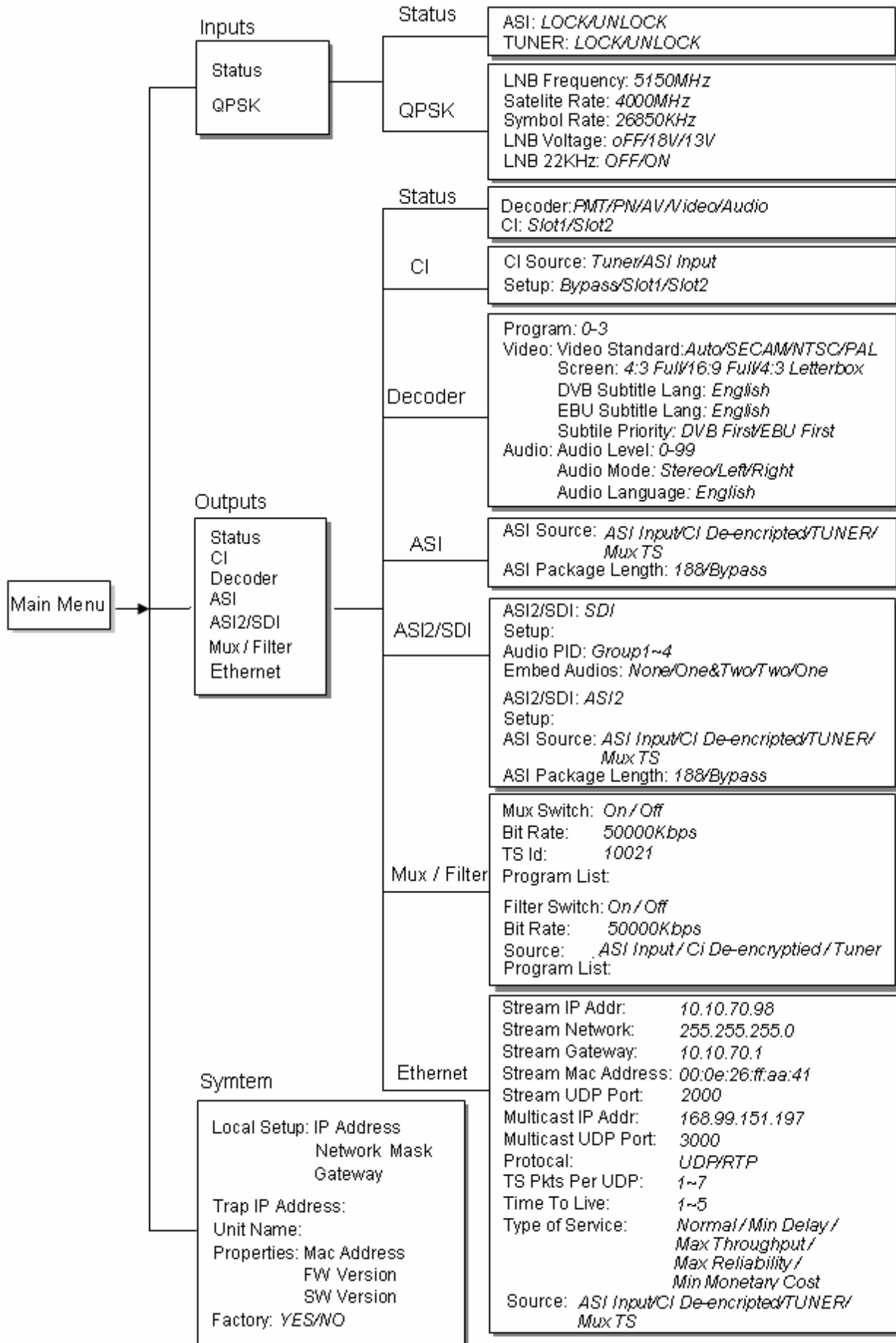
Note that the TS over IP input also could be configured as the source of CI, ASI, ASI2 and Mux/Filter.

## 9. Manual for DCH-4000P-42S /-42T/-42C/-42S2

### 9.1 Menu Structure for DCH-4000P-42S /-42T/-42C/-42S2

**Note:** the Input menu differs from DCH-4000P-42S /-42T/-42C/-42S2 models according to the different type of tuner.

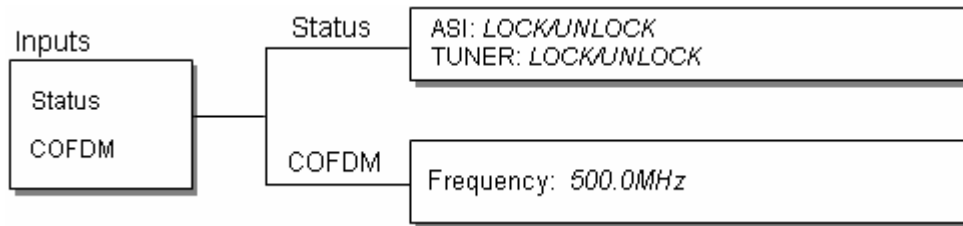
## DCH-4000P-xx series Receivers



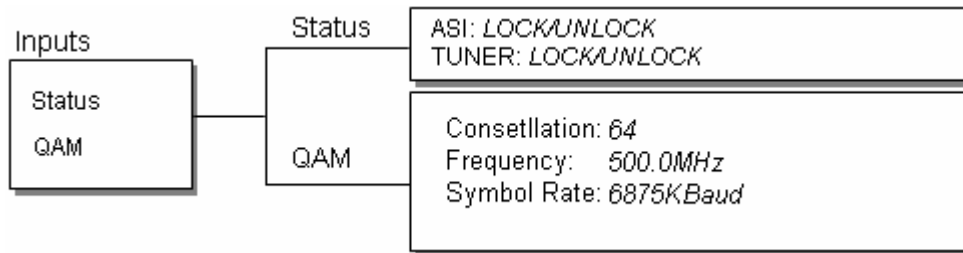
Team-up with **PBI**, Brighten Your Digital View !

## DCH-4000P-xx series Receivers

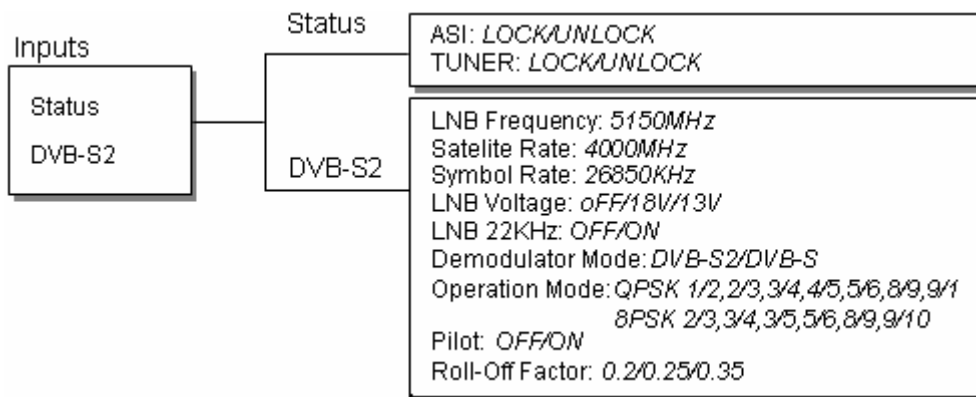
**Figure 9.1 Full Menu Structure for DCH-4000P-42S**



**Figure 9.2 Inputs Menu Structure for DCH-4000P-42T**



**Figure 9.3 Inputs Menu Structure for DCH-4000P-42C**



**Figure 9.4 Inputs Menu Structure for DCH-4000P-42S2**

## 9.2 Setting Inputs for DCH-4000P-42S /-42T/-42C/-42S2

Please refer to **paragraph 7.2** for the setting method.



### 9.3 Setting Outputs for DCH-4000P-42S /-42T/-42C/-42S2

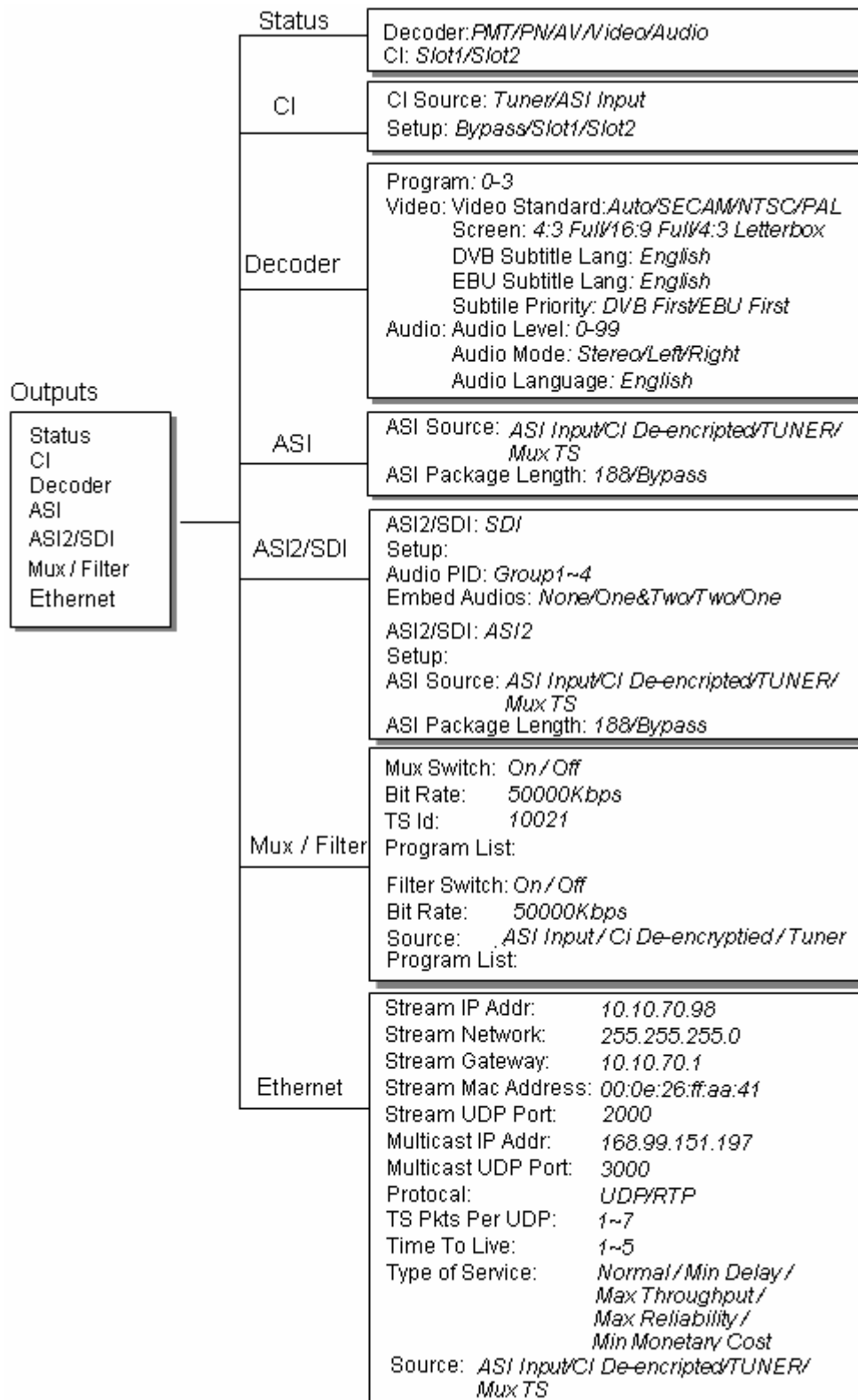


Figure 9.5 Outputs Menu Structure for DCH-4000P-42S /-42T/-42C/-42S2

### 9.3.1 Setting the Ethernet TS over IP output

The Ethernet connector could also be configured as the output of the transport stream over IP. The parameters listed below must be set to appropriate values for the network over which the transport stream over IP is broadcasted.

- **Stream IP Address:** Enter the IP address for streaming IP output of the unit.
- **Stream Network Mask:** Enter the network sub mask for the subnet to which the unit is connected for IP streaming traffic.
- **Stream Gateway:** Set the gateway for the network to which the unit is connected for IP streaming traffic.
- **Stream Mac Address:** factory-set MAC addresses are guaranteed to be unique. Therefore you cannot configure the address.
- **Multicast IP address:** Enter the IP address of the multicast stream for the transport stream over IP output.
- **UDP Port:** Enter the UDP port number of the TS over IP stream output.
- **Protocol:** select the protocol for multicast: UDP or RTP.
- **TS Pkts Per UDP:** set the number of the TS packages encapsulated in one UDP package. The valid range goes from 1 to 7.
- **Time To Live:** set the number of the routers over which the TS over IP can be transmitted. The valid range goes from 1 to 5.
- **Type of Service:** select the type of service. There are: Normal, Min Monetary Cost, Max Reliability, Max Throughput or Min Delay optional.
- **Source:** select the source of the TS over IP streaming output. There are: ASI Input, CI De-encrypted or TUNER.

### 9.3.2 Other output settings for DCH-4000P-42S /-42T/-42C/-42S2

Please refer to **paragraph 7.3** for the other output setting method.

## 10. REMOTE MONITORING AND CONTROL

The DCH-4000P-xx series provides an Ethernet remote control interface for user remote control or supervise one or multiple DCH-4000P-xx via the Headend Devices Management System (HDMS).

### 10.1 Install HDMS to a PC

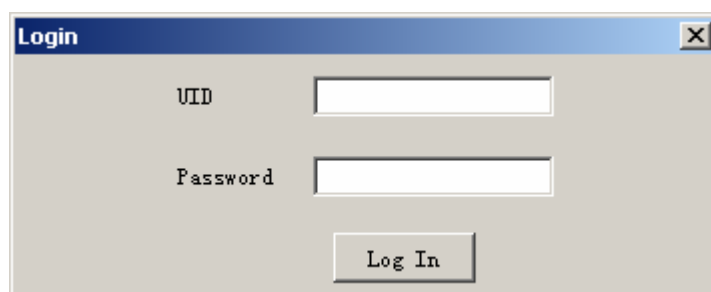
The HDMS Installation.exe file could be found on the CD-ROM which is enclosed in the original package. Detailed information about installation can be found in the *HDMS Reference Guide*.

### 10.2 Connect to HDMS


After installation of HDMS, you need to configure the local settings of the DCH-4000P-xx (s) which is/are expected to connect to the remote control network. Please refer to **paragraph 6.2.1**.


### 10.3 Login to HDMS

To login on HDMS, a user account and password are needed. Default user account is: administrator, password is: admin. You can create or delete new accounts. Detailed information can be found in the *HDMS Reference Guide*.



### 10.4 Add DCH-4000P-xx to HMDS

Ensure the DCH-4000P-xx are well connected with the network over which the PC that installed the HDMS can access the DCH-4000P-xx. Press the  icon in the top left of the window in HDMS to and the system will search the DCH-4000P-xx automatically. The units which are searched will be displayed in the Devices Window in HDMS.

When a new DCH-4000P-xx is added to the remote control network, you can press  to refresh the network. The new added unit will be added into the HDMS automatically. For other methods for adding one or a group of DCH-4000P-xx, please refer to the *HDMS Reference Guide*.

### 10.5 DCH-4000P-xx in HDMS

Double click on the device in the Devices Management window to open the console of the DCH-4000P-xx. The HDMS provides full operation to the DCH-4000P-xx. Parameters are grouped in three panels:

- **The Input Setting**, which gives the full operation on inputs parameters.
- **The Output Setting**, allows the full operation control functions on outputs parameters.
- **The System Setting**, shows the general device management parameters.

Each console has four control buttons:

- **Apply**: to apply the current settings for the unit which is being accessed.
- **Refresh**: to obtain the current settings from the unit.
- **Load**: to load the pre-settings files to the HDMS, and press "Apply" to apply the pre-settings for the unit.
- **Save**: save the user's settings as an .xml file.

**Remark:** When duplicating the configuration of one device to the other unit(s), you need to modify the System Setting (such as IP address, gateway, Unit name, etc) manually after loading the .xml file.

## 10.6 Other Settings

The HDMS provides also Alarms management, Devices management, and User accounts management. It may also be necessary to modify some of the other settings to suit the particular installation, please see the *HDMS Reference Guide* for details.

## 11. FAQ

### 1. Why is there nothing in the LCD?

**Answer:** Please check whether the power supply is connected well first. If not, insert it well and turn on the device. If there is still nothing displayed on the LCD, then the unit may be damaged, please contact the agent for technical support.

### 2. Why can the QPSK/QAM/COFDM/DVB-S2 signal not be locked?

**Answer:** Please ensure whether the input cable is connected well first. If not, insert it well. If it is connected well, please check whether all the necessary parameters are set properly. If not, please set the parameters properly. If the signal still cannot be locked, please check whether the quality of the signal is out of the threshold of the Tuner. If not, then the device might be damaged, please contact the agent for support.

### 3. Why can the ASI not be locked?

**Answer:** Please make sure the BNC cable is connected well and there are programs transmitted to the unit via the BNC cable.

## 12. Appendix

### 12.1 Specification

<b>QPSK Demodulation &amp; FEC Parameters</b>	
Input Frequency Range	C & Ku Band, 950~2150 MHz
Input Level	-25 dBm ~ -65 dBm
Input Impedance	75 Ω F type
Symbol Rate	2~45 Mb/s (SCPC or MCPC)
Rolling Off Factory	0.20 or 0.35
Punctured Rates	1/2, 2/3, 3/4, 5/6, 6/7, 7/8
Reeds Salomon Decoding	204, 188, T = 8 & I=12
<b>DVB-C QAM Demodulation</b>	
Connector	IEC, Female (7/8 MHz) or F Female (6 MHz) Input
Input Symbol Rate Range	1~7 Mbs (PAL), 1~6 Mbps (NTSC)
Demodulation	16/32/64/128/256 QAM
Tuner Bandwidth	6 MHz or 7 MHz or 8 MHz factory optional
FEC Decoder	1/2, 2/3, 3/4, 5/6, 7/8; K=7

Team-up with **PBI**, Brighten Your Digital View !

## DCH-4000P-xx series Receivers

Frequency Range	50~860 MHz
Digital Signal Input Level	-15~15 dBmV
Input Impedance	75 Ω F-type
<b>DVB-T COFDM Demodulation</b>	
Connector	IEC, Female (7/8 MHz) or F Female (6 MHz) Input
1 IF Loop through	Yes
Frequency Range	470-862 MHz, 174-230 MHz
Input Symbol Rate Range	4.98~31.67 Mbit/s (8 MHz bandwidth)
Constellation	QPSK, 16-QAM, 64-QAM
Tuner Bandwidth	8 MHz
Digital Signal Input Level	-20 to -75 dBmV
Input Impedance	75 Ω unbalanced
FFT mode	2K/8K
Guard Interval	1/4, 1/8, 1/16, 1/32, off
FEC Code Rate	1/2, 2/3, 3/4, 5/6 and 7/8
<b>DS3 Input</b>	
Input Impedance	75 Ω
Connector	BNC
Maximum Input Code Rate	44.736 Mbit/s
Format	Unframed Framing according to G.804/G.752 (DS3)
<b>DS3 Loop Through Output</b>	
Impedance	75 Ω
Maximum Output Code Rate	44.736 Mbit/s
Connector	BNC
Format	Unframed Framing according to G.804/G.752 (DS3)
<b>TS over IP Output</b>	
Connector	100 base-T RJ45
Output Bit Rate	70 Mbits/s Max.
UDP/RTP	Multicast or Unicast
Multicast Control Protocol	IGMPV2
<b>I/O Interface on back panel</b>	
LNB I/O	1×Input, 1×loop through output
RS-232	1×9-pin D-sub male
RJ45	1×Ethernet control port, 1×TS over IP output (factory optional)
ASI input	1
ASI output	2×Redundant output
SDI output	1 (optional)
RGB output	1×RCA
CVBS output	1×RCA, 1×BNC

*Team-up with **PBI**, Brighten Your Digital View !*

## DCH-4000P-xx series Receivers

---

Audio XRL Balance Output	1
<b>General</b>	
Operating Temperature	0-45 °C
Storage Temperature	-20~70 °C
Humidity	<85%
Power Supply	AC 90V~260V 50Hz/60Hz
Dimensions	483 mm×255 mm×44 mm
Approximately Net Weight	5 kg

## Pro Broadband Inc.

---

Tel: +86 (0)10 6263 8833

Fax: +86 (0)10 6263 7776

Website: [www.pbi-china.com](http://www.pbi-china.com)

E-Mail: [market@pbicn.com](mailto:market@pbicn.com)

This document and the information contained in it is the property of Pro Broadband Inc. and may be the subject of patents pending and granted. It must not be used for commercial purposes nor copied, disclosed, reproduced, stored in a retrieval system or transmitted in any form or by any means (electronic, mechanical, photocopying, recording or otherwise), whether in whole or in part, without Pro Broadband Inc.'s prior written agreement.

© 2007 Pro Broadband Inc. All rights reserved.

*Team-up with **PBI**, Brighten Your Digital View !*