

Features

- ◆ Operating data rate up to 10.3Gbps
- ◆ 1310nm DFB-LD Transmitter
- ◆ Distance up to 10km
- ◆ Single 3.3V Power supply and TTL Logic Interface
- ◆ Duplex LC Connector Interface
- ◆ Hot Pluggable
- ◆ Compliant with MSA SFP+ Specification SFF-8431
- ◆ Compliant with 10GFC 1200-SM-LL-L FC standard
- ◆ Compliant with 8.5G FC-PI-4 800-SM-LC-L FC standard
- ◆ Compliant with 4.25G FC-PI-4 400-SM-LC-L FC standard
- ◆ Compliant with 2.125G FC-PI-4 200-SM-LC-L FC standard
- ◆ Compliant with 1.0625G FC-PI-4 100-SM-LC-L FC standard
- ◆ Compliant with IEEE 802.3ae 10GBASE-LR/LW
- ◆ Operating Case Temperature

Standard: -10C~+70C



Applications

- ◆ 10GBASE-LR at 10.31Gbps
- ◆ 10GBASE-LW at 9.95Gbps
- ◆ 1000 Base-LX Ethernet
- ◆ 8XFC at 8.5Gbps
- ◆ 4XFC at 4.25Gbps
- ◆ 2XFC at 2.125Gbps
- ◆ 1xFC at 1.0625Gbps
- ◆ Other optical links

Ordering information

Part No.	Data Rate	Laser	Fiber Type	Distance	Optical Interface	DDMI
SNR-SFP+LR*	1.0625Gbps to 10.3Gbps	1310nm DFB	SMF	10km	LC	YES

*Operating case temperature range is -5C~+70C

Regulatory Compliance

Feature	Standard	Performance
Electrostatic Discharge (ESD) to the Electrical Pins	MIL-STD-883G Method 3015.7	Class 1C (>1000 V)
Electrostatic Discharge to the enclosure	EN 55024:1998+A1+A2 IEC-61000-4-2 GR-1089-CORE	Compliant with standards
Electromagnetic Interference (EMI)	FCC Part 15 Class B EN55022:2006 CISPR 22B :2006 VCCI Class B	Compliant with standards Noise frequency range: 30 MHz to 6 GHz. Good system EMI design practice required to achieve Class B margins. System margins depend on customer host board and chassis design.
Immunity	EN 55024:1998+A1+A2 IEC 61000-4-3	Compliant with standards. 1kHz sine-wave, 80% AM, from 80 MHz to 1 GHz. No effect on transmitter/receiver performance is detectable between these limits.
Laser Eye Safety	FDA 21CFR 1040.10 and 1040.11 EN (IEC) 60825-1:2007 EN (IEC) 60825-2:2004+A1	CDRH compliant and Class I laser product. TüV Certificate No. 50135086
Component Recognition	UL and CUL EN60950-1:2006	UL file E317337 TüV Certificate No. 50135086 (CB scheme)
RoHS6	2002/95/EC 4.1&4.2 2005/747/EC 5&7&13	Compliant with standards ^{*note2}

Note1: For update of the equipments and strict control of raw materials, SNR has the ability to supply the customized products since Jan 1st, 2007, which meets the requirements of RoHS6 (Restrictions on use of certain Hazardous Substances) of European Union.

In light of item 5 in RoHS exemption list of RoHS Directive 2002/95/EC, Item 5: Lead in glass of cathode ray tubes, electronic components and fluorescent tubes.

In light of item 13 in RoHS exemption list of RoHS Directive 2005/747/EC, Item 13: Lead and cadmium in optical and filter glass. The three exemptions are being concerned for SNR's transceivers, because SNR's transceivers use glass, which may contain Pb, for components such as lenses, windows, isolators, and other electronic components.

Product Description

The SNR-SFP+LR series single mode transceiver is small form factor pluggable module for serial optical data communications such as X1/X2/X4/X8 Fiber Channel, IEEE 802.3ae

10GBASE-LR/LW. It is with the SFP+ 20-pin connector to allow hot plug capability.

This module is designed for single mode fiber and operates at a nominal wavelength of 1310 nm. The transmitter section uses a 1310nm multiple quantum well DFB laser and is a class 1 laser compliant according to International Safety Standard IEC-60825.

The receiver section uses an integrated InGaAs detector preamplifier (IDP) mounted in an optical header and a limiting post-amplifier IC.

Absolute Maximum Ratings

Parameter	Symbol	Min.	Max.	Unit
Storage Temperature	T_s	-40	+85	°C
Supply Voltage	V_{CC}	-0.5	3.6	V
Input Voltage	V_{in}	-0.5	V_{CC}	V
Output Current	I_o	-	50	mA

Recommended Operating Conditions

Parameter	Symbol		Min.	Typical	Max.	Unit
Operating Case Temperature	T_A	SNR-SFP+LR	-10		+70	°C
Power Supply Voltage	V_{CC}		3.15	3.3	3.45	V
Power Supply Current	I_{CC}				300	mA
Surge Current	I_{Surge}				+30	mA
Baud Rate	10GBASE-LR			10.31		Gbps
	10GBASE-LW			9.95		
	8XFC			8.5		
	4XFC			4.25		
	2XFC			2.125		
	1XFC			1.0625		

Performance Specifications - Electrical

Parameter	Symbol	Min.	Typ.	Max	Unit	Notes
Transmitter						
CML Inputs(Differential)	V_{in}	150		1200	mVpp	AC coupled inputs
Input AC Common Mode Voltage		0		25	mV	RMS
Input Impedance (Differential)	Z_{in}	85	100	115	ohm	$R_{in} > 100 \text{ kohms}$ @ DC
Differential Input S-parameter	S_{DD11}	-	-	-10	dB	

Differential to Common Mode Conversion	S_{CD11}	-	-	-10	dB	
Tx_DISABLE Input Voltage - High		2		3.45	V	
Tx_DISABLE Input Voltage - Low		0		0.8	V	
Tx_FAULT Output Voltage -- High		2		$V_{CC}+0.3$	V	$I_o = 400\mu A$; Host V_{CC}
Tx_FAULT Output Voltage -- Low		0		0.5	V	$I_o = -4.0mA$
Receiver						
CML Outputs (Differential)	V_{out}	350		700	mVpp	AC coupled outputs
Output AC Common Mode Voltage		0		15	mV	RMS
Output Impedance (Differential)	Z_{out}	90	100	110	ohm	
Differential Output S-parameter	S_{D22}	-	-	-10	dB	
Rx_LOS Output Voltage - High		2		$V_{CC}+0.3$	V	$I_o = 400\mu A$; Host V_{CC}
Rx_LOS Output Voltage - Low		0		0.8	V	$I_o = -4.0mA$
MOD_DEF (0:2)	VoH	2.5			V	With Serial ID
	VoL	0		0.5	V	

Performance Specifications - Optical

Parameter	Symbol	Min.	Typical	Max.	Unit
9µm Core Diameter SMF			10		Km
Data Rate				10.3	Gbps
Transmitter					
Centre Wavelength	λ_C	1270	1310	1355	nm
Spectral Width (-20dB)	$\Delta\lambda$			1	nm
Average Output Power@10.3Gbps	P_{out}	-3		+1	dBm
Extinction Ratio@10.3Gbps	ER	3.5			dB
Average Power of OFF Transmitter	P_{off}			-30	dBm
Side Mode Suppression Ratio	SMSR	30			dB
Input Differential Impedance	Z_{IN}	90	100	110	Ω
TX Disable	Disable		2.0	$V_{CC}+0.3$	V
	Enable		0	0.8	
TX Fault	Fault		2.0	$V_{CC}+0.3$	V
	Normal		0	0.8	

TX Disable Assert Time	t_off	-	-	10	us
TX_DISABLE Negate Time	t_on	-	-	1	ms
TX_BISABLE time to start reset	t_reset	10	-	-	us
Time to initialize, include reset of TX_FAULT	t_init	-	-	300	ms
TX_FAULT from fault to assertion	t_fault	-	-	100	us
Total Jitter	TJ	-	-	0.28	UI(p-p)
Data Dependant Jitter	DDJ	-	-	0.1	UI(p-p)
Uncorrelated Jitter	UJ	-	-	0.023	RMS
Receiver					
Centre Wavelength	λ	1260		1565	nm
Sensitivity@10.3Gbps	P _{min}			-14	dBm
Receiver Overload	P _{max}	0.5			dBm
Optical Return Loss	ORL			-12	dB
LOS De-Assert	LOS _D			-15	dBm
LOS Assert	LOS _A	-25			dBm
LOS	High		2.0	V _{CC} +0.3	V
	Low		0	0.8	

SFP+ Transceiver Electrical Pad Layout

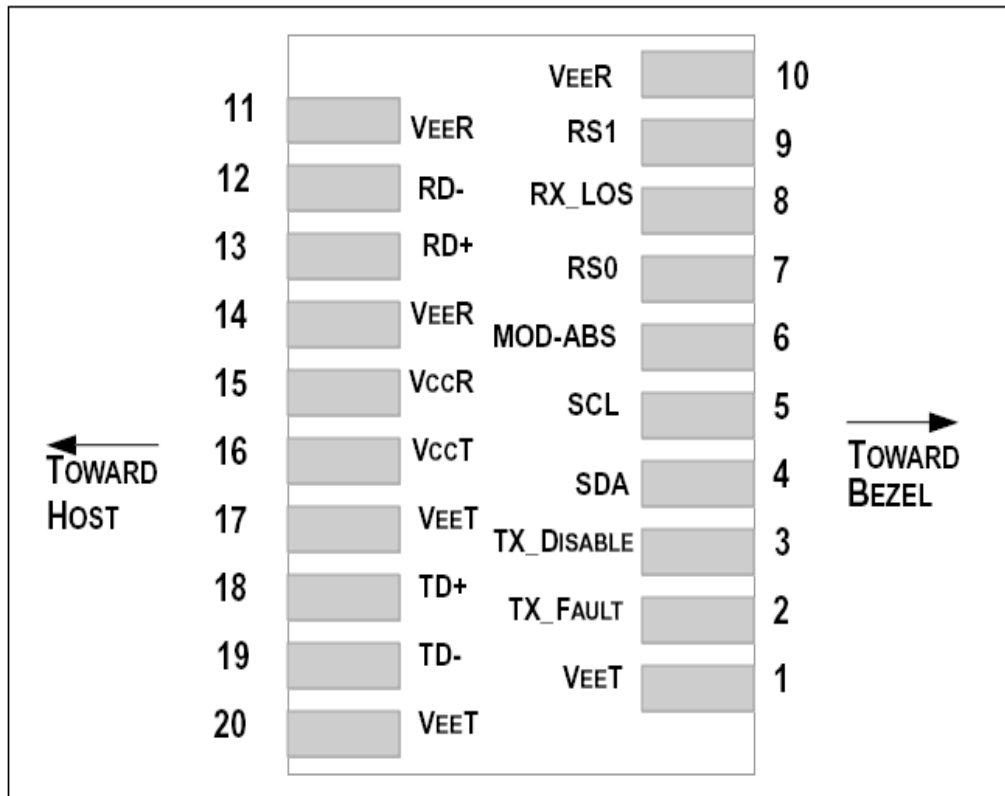

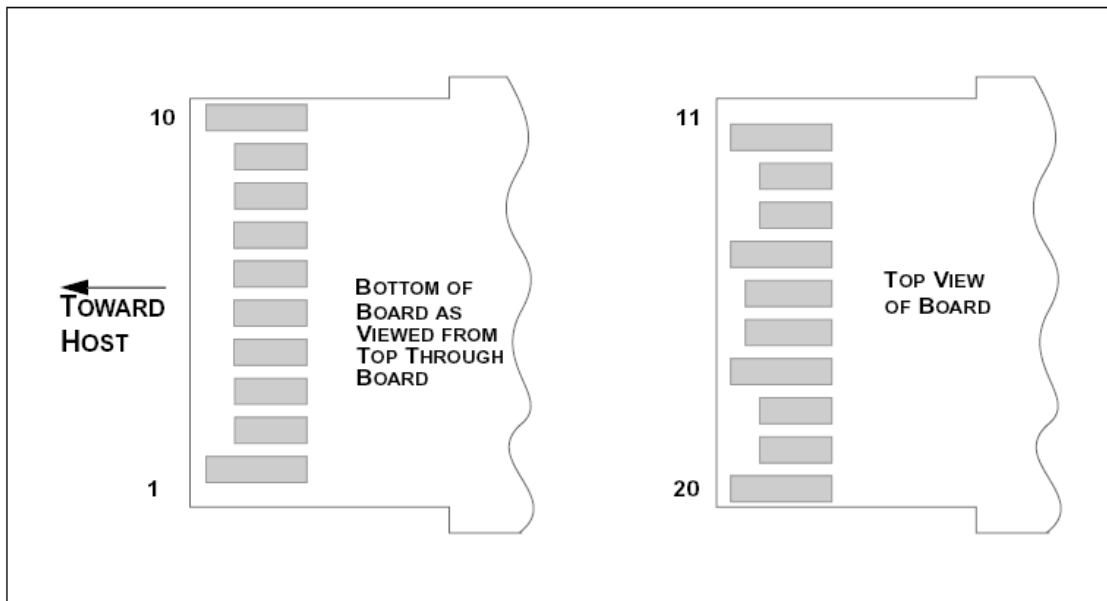

Pin Function Definitions

Pin Num.	Name	FUNCTION	Plug Seq.	Notes
1	VeeT	Transmitter Ground	1	Note 5
2	TX Fault	Transmitter Fault Indication	3	Note 1
3	TX Disable	Transmitter Disable	3	Note 2, Module disables on high or open
4	SDA	Module Definition 2	3	Note 3, Data line for Serial ID.
5	SCL	Module Definition 1	3	Note 3, Clock line for Serial ID.
6	MOD-ABS	Module Definition 0	3	Note 3
7	RS0	RX Rate Select (LVTTTL).	3	This pin has an internal 30k pull down to ground. A signal on This pin will not affect module performance.
8	LOS	Loss of Signal	3	Note 4
9	RS1	TX Rate Select (LVTTTL).	1	This pin has an internal 30k pull down to ground. A signal on This pin will not affect module performance.
10	VeeR	Receiver Ground	1	Note 5
11	VeeR	Receiver Ground	1	Note 5
12	RD-	Inv. Received Data Out	3	Note 6
13	RD+	Received Data Out	3	Note 7
14	VeeR	Receiver Ground	1	Note 5

15	VccR	Receiver Power	2	3.3 ± 5%, Note 7
16	VccT	Transmitter Power	2	3.3 ± 5%, Note 7
17	VeeT	Transmitter Ground	1	Note 5
18	TD+	Transmit Data In	3	Note 8
19	TD-	Inv. Transmit Data In	3	Note 8
20	VeeT	Transmitter Ground	1	Note 5

Notes:

1) TX Fault is an open collector/drain output, which should be pulled up with a 4.7K – 10KΩ resistor on the host board. Pull up voltage between 2.0V and VccT, R+0.3V. When high, output indicates a laser fault of some kind. Low indicates normal operation. In the low state, the output will be pulled to < 0.8V.

2) TX disable is an input that is used to shut down the transmitter optical output. It is pulled up within the module with a 4.7 – 10 KΩ resistor. Its states are:

Low (0 – 0.8V): Transmitter on

(>0.8, < 2.0V): Undefined

High (2.0 – 3.465V): Transmitter Disabled

Open: Transmitter Disabled

3) Modulation Absent, connected to VEET or VEER in the module.

4) LOS (Loss of Signal) is an open collector/drain output, which should be pulled up with a 4.7K – 10KΩ resistor. Pull up voltage between 2.0V and VccT, R+0.3V. When high, this output indicates the received optical power is below the worst-case receiver sensitivity (as defined by the standard in use). Low indicates normal operation. In the low state, the output will be pulled to < 0.8V.

5) VeeR and VeeT may be internally connected within the SFP+ module.

6) RD-/+ : These are the differential receiver outputs. They are AC coupled 100Ω differential lines which should be terminated with 100Ω (differential) at the user SERDES. The AC coupling is done inside the module and is thus not required on the host board.

7) VccR and VccT are the receiver and transmitter power supplies. They are defined as 3.3V ±5% at the SFP+ connector pin. Maximum supply current is 300mA. Inductors with DC resistance of less than 1 ohm should be used in order to maintain the required voltage at the SFP+ input pin with 3.3V supply voltage. When the recommended supply-filtering network is used, hot plugging of the SFP+ transceiver module will result in an inrush current of no more than 30mA greater than the steady state value. VccR and VccT may be internally connected within the SFP+ transceiver module.

8) TD-/+ : These are the differential transmitter inputs. They are AC-coupled, differential lines with 100Ω differential termination inside the module. The AC coupling is done inside the module and is thus not required on the host board.

EEPROM

The serial interface uses the 2-wire serial CMOS EEPROM protocol defined for the ATMEL AT24C02/04 family of components. When the serial protocol is activated, the host generates the serial clock signal (SCL). The positive edge clocks data into those segments of the EEPROM that are not write protected within the SFP+ transceiver. The negative edge clocks data from the SFP+ transceiver. The serial data signal (SDA) is bi-directional for serial data transfer. The host uses SDA in conjunction with SCL to mark the start and end of serial protocol activation. The memories are organized as a series of 8-bit data words that can be addressed individually or sequentially.

The Module provides diagnostic information about the present operating conditions. The transceiver generates this diagnostic data by digitization of internal analog signals. Calibration and alarm/warning threshold data is written during device manufacture. Received power monitoring, transmitted power monitoring, bias current monitoring, supply voltage monitoring and temperature monitoring all are implemented. If the module is defined as external calibrated, the diagnostic data are raw A/D values and must be converted to real world units using calibration constants stored in EEPROM locations 56 – 95 at wire serial bus address A2h. The digital diagnostic memory map specific data field define as following .For detail EEPROM information, please refer to the related document of SFF 8472 Rev 10.2.

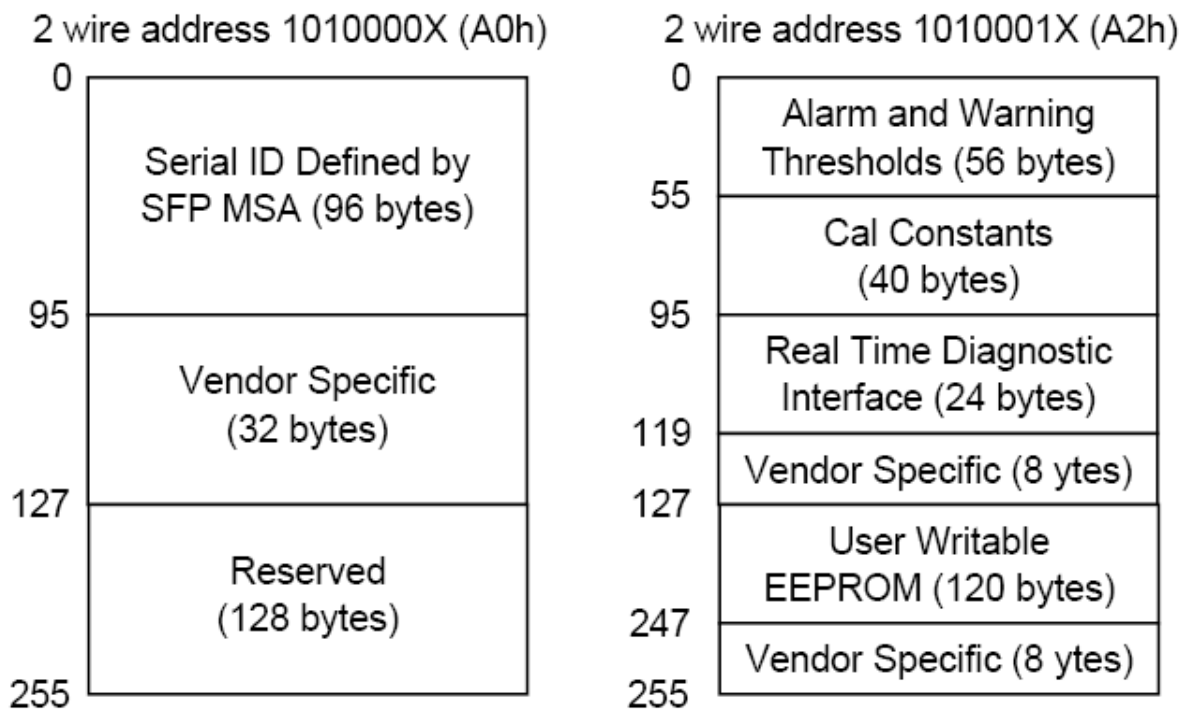

Recommend Circuit Schematic

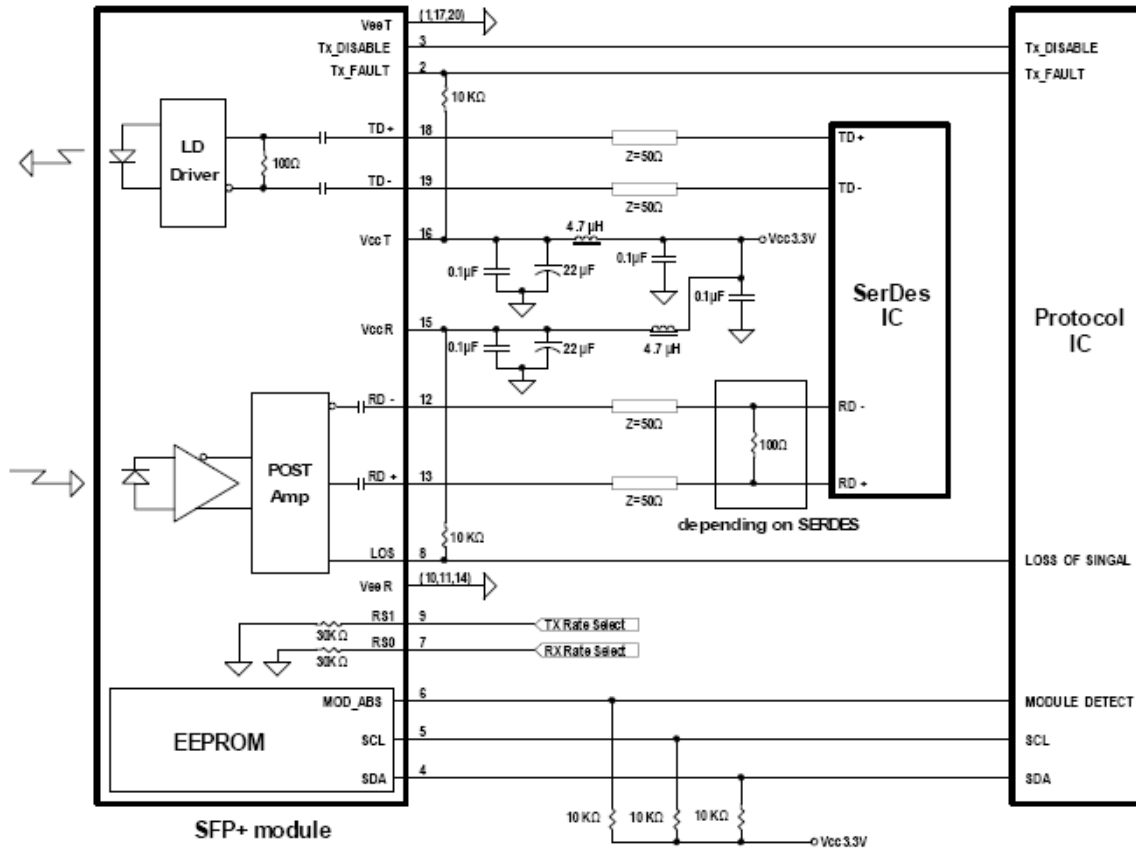

Mechanical Specifications

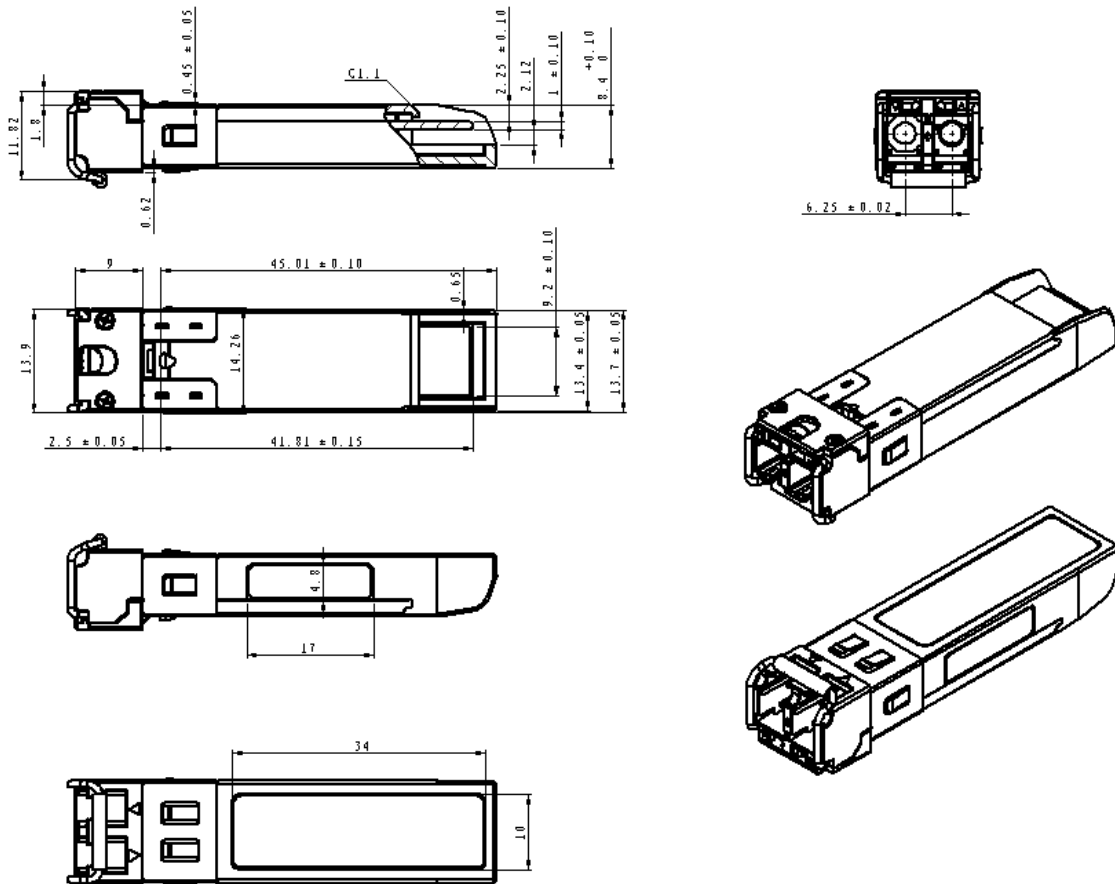

Eye Safety

This single-mode transceiver is a Class 1 laser product. It complies with IEC-60825 and FDA 21 CFR 1040.10 and 1040.11. The transceiver must be operated within the specified temperature and voltage limits. The optical ports of the module shall be terminated with an optical connector or with a dust plug.

Notice:

SNR reserves the right to make changes to or discontinue any optical link product or service identified in this publication, without notice, in order to improve design and/or performance. Applications that are described herein for any of the optical link products are for illustrative purposes only. SNR makes no representation or warranty that such applications will be suitable for the specified use without further testing or modification.

GUARANTEE:



CONTACT:

Address: Building 118, Vonsovskogo Street 1, Yekaterinburg, Russia

Tel: +7(343) 379-98-38

Fax: +7(343) 379-98-38

E-mail: info@nag.ru

Online shop: <http://shop.nag.ru>