



Huawei CloudEngine 6866 Switch Datasheet

Huawei CloudEngine 6866 series switches have advanced hardware architecture with 100GE/200GE uplink ports and high-density 10GE/25GE/50GE access ports.

CloudEngine 6866 series can be used to build a scalable data center network platform in the cloud computing era, or work as core or aggregation switches on campus networks.

Product Overview

Huawei CloudEngine 6866 series switches are next-generation 10GE/25GE/50GE access switches that provide high performance and high port density on data center networks and high-end campus networks. The CloudEngine 6866 series have advanced hardware architecture with 100GE/200GE uplink ports and high-density 10GE/25GE/50GE access ports. CloudEngine 6866 series switches support extensive data center features. In addition, the CloudEngine 6866 series use a flexible airflow design (front-to-back or back-to-front).

CloudEngine 6866 series can work with CloudEngine 16800 or CloudEngine 8851 series data center core switches to build elastic, virtual, and high-quality 100GE/200GE full-mesh networks, meeting requirements of cloud computing data centers.

CloudEngine 6866 series provide high-density 10GE/25GE/50GE access to help enterprises and carriers build a scalable data center network platform in the cloud computing era. They can also work as core or aggregation switches on campus networks.

Product Appearance

The CloudEngine 6866-48S8CQ-P provides 48*25GE SFP28 or 48*50GE SFP56 downlink ports, and 8*100GE QSFP28 or 8*200GE QSFP56 uplink ports.



Product Characteristics

High-Density 50GE/25GE Access

- CloudEngine 6866 series provide up to 48 x 10GE/25GE/50GE ports, allowing for high-density 10GE/25GE/50GE server access and smooth evolution.
- CloudEngine 6866 series provide up to 8 x 100GE QSFP28 or 8 x 200GE QSFP56 ports. Each 100GE QSFP28 port can be used as one 40GE QSFP+ port. The uplink 100GE/200GE ports can be connected to CloudEngine 16800 or CloudEngine 8851 series switches to build a non-blocking network platform.

Inter-device Link Aggregation, High Efficiency and Reliability

- CloudEngine 6866 series support multi-chassis link aggregation group (M-LAG), which enables links of multiple switches to aggregate into one to implement device-level link backup.
- Switches in an M-LAG all work in active state to share traffic and back up each other, enhancing system reliability.
- Switches in an M-LAG can be upgraded independently. During the upgrade, other switches in the system take over traffic forwarding to ensure uninterrupted services.
- M-LAG supports dual-homing to Ethernet, VXLAN, and IP networks, allowing for flexible networking.

Virtualized Hardware Gateway, Enabling Quick Deployment

- CloudEngine 6866 series can connect to a cloud platform through open APIs, facilitating unified management of virtual and physical networks.
- CloudEngine 6866 series can work with the industry's mainstream virtualization platforms. The virtualization function protects investments because services can be deployed quickly without requiring network changes.
- The hardware gateway deployment enables fast service deployment without changing the customer network, providing investment protection.
- CloudEngine 6866 series support Border Gateway Protocol - Ethernet VPN (BGP-EVPN), which can run as the VXLAN control plane to simplify VXLAN configuration within and between data centers.

Standard Interfaces, Enabling Openness and Interoperability

- CloudEngine 6866 series support NETCONF and can work with Huawei iMaster NCE-Fabric.
- CloudEngine 6866 series support Ansible-based automatic configuration and open-source module release, expanding network functions and simplifying device management and maintenance.
- CloudEngine 6866 series can be integrated into mainstream SDN and cloud computing platforms flexibly and quickly.

ZTP, Implementing Automatic O&M

- CloudEngine 6866 series support Zero Touch Provisioning (ZTP). ZTP enables the CloudEngine 6866 series to automatically obtain and load version files from a USB flash drive or file server, freeing network engineers from onsite configuration and deployment. ZTP reduces labor costs and improves device deployment efficiency.
- ZTP provides built-in scripts through open APIs. Data center personnel can use a programming language they are familiar with, such as Python, to centrally configure network devices.
- ZTP decouples the configuration time of new devices from the device quantity and area distribution, which improves service provisioning efficiency.

FabricInsight-based Intelligent O&M

- The CloudEngine 6866 provides telemetry technology to collect device data in real time and send the data to Huawei data center network analyzer iMaster NCE-FabricInsight. The iMaster NCE-FabricInsight analyzes network data based on the intelligent fault identification algorithm, accurately displays the real-time network status, effectively demarcates and locates faults in a timely manner, and identifies network problems that affect user experience, accurately guaranteeing user experience.

iMaster NCE-based Simplified Network Deployment

- CloudEngine 6866 series switches can interconnect with iMaster NCE-Fabric through standard protocols such as NetConf and SNMP to implement network automatic management and control, providing more efficient and intelligent operation methods, simplifying network management, and reducing the OPEX.

Flexible Airflow Design, Improving Energy Efficiency

Flexible front-to-back or back-to-front airflow design

- CloudEngine 6866 series use a strict front-to-back or back-to-front airflow design that isolates cold air channels from hot air channels. This design improves heat dissipation efficiency and meets design requirements of data center equipment rooms.
- Air can flow from front to back or back to front depending on the fans and power modules that are used.
- Redundant power modules and fans can be configured to ensure service continuity.

Innovative energy-saving technologies

- CloudEngine 6866 series have innovative energy-saving chips and can measure system power consumption in real time. The fan speed can be adjusted dynamically based on system consumption. These energy-saving technologies reduce O&M costs and contribute to a greener data center.

Clear Indicators, Simplifying Maintenance

Clear indicators

- Port indicators clearly show the port status and port rate. The 100GE port indicators can show the states of all ports derived from the 100GE ports.
- State indicators on both the front and rear panels enable users to maintain the switch from either side.
- CloudEngine 6866 series support remote positioning. Remote positioning indicators enable users to easily identify the switches they want to maintain in an equipment room full of devices.

Simple maintenance

- The management port, fans, and power modules are on the front panel, which facilitates device maintenance.
- Data ports are located at the rear, facing servers. This simplifies cabling.

Licensing

CloudEngine 6866 supports Huawei IDN One Software (N1 mode for short) licensing mode. The CloudFabric N1 business model combines the NCE controller, analyzer, and CloudEngine switch software for use in a range of common scenarios. This simplifies transactions, provides customers with more functions and value, and protects their software investment with Software License Portability.

Product	Feature	N1 Mandatory Software Packages			N1 Add-on Software Packages		
		Foundation	Advanced	Premium	Security Function	AI Fabric RDMA Application Acceleration Function Package	Multi-cloud Multi-DC Value-added Package
CloudEngine 6866 series switch	Basic software	√	√	√			
	IPv6	√	√	√			
	VXLAN	√	√	√			
	Lossless upgrade	√	√	√			
	Telemetry	√	√	√			
	NSH		√	√			
	MACsec				√		
	LLETH					√	
	AI ECN					√	
iMaster NCE-Fabric	Automatic deployment function	√	√	√			
	Basic intent functions (simulation and verification, and network-wide configuration rollback)			√			
	Multi-cloud multi-DC function						√
iMaster NCE-FabricInsight	Basic network analysis functions of telemetry	√	√	√			
	Network health evaluation		√	√			
	Value-added functions for network traffic analysis (managing 100 VMs)			√			
Version Mapping		Select one from three options. The Advanced software package contains functions of the Foundation software			It is used with the Foundation, Advanced, or Premium software package.		

Product	Feature	N1 Mandatory Software Packages	N1 Add-on Software Packages
		package, and the Premium software package contains functions of the Advanced software package.	
For details about product function differences, refer to the product documentation.			

Note: For detailed information of Huawei CloudFabric N1 business model, visit <https://e.huawei.com/en/material/networking/dcs/switch/03a0e69bfa2c4f168323ba94a75f1f09>.

Product Specifications

Note: This content is applicable only to regions outside Chinese mainland. Huawei reserves the right to interpret this content.

Functions and Features

Item	CloudEngine 6866-48S8CQ-P
Device virtualization	M-LAG
Network virtualization	VXLAN
	BGP-EVPN
Data center interconnect (DCI)	VXLAN mapping, implementing interconnection between multiple DCI networks at Layer 2
SDN	iMaster NCE-Fabric
Network convergence	PFC and AI ECN
	RDMA and RoCE (RoCEv1 and RoCEv2)
Programmability	OPS programming
	OpenFlow
	Ansible-based automatic configuration and open-source module release
Traffic analysis	NetStream
VLAN	Adding access, trunk, and hybrid interfaces to VLANs
	Default VLAN
MAC address	Dynamic learning and aging of MAC address entries
	Static, dynamic, and blackhole MAC address entries
	Packet filtering based on source MAC addresses
	MAC address limiting based on ports and VLANs
IP routing	IPv4 routing protocols, such as RIP, OSPF, IS-IS, and BGP
	IPv6 routing protocols, such as RIPng, OSPFv3, IS-ISv6, and BGP4+
IPv6	VXLAN over IPv6
	IPv6 VXLAN over IPv4
	IPv6 Neighbor Discovery (ND)
	Path MTU Discovery (PMTU)

Item	CloudEngine 6866-48S8CQ-P
	TCP6, IPv6 ping, IPv6 tracer, IPv6 socket, UDP6, and raw IPv6
Multicast	Multicast routing protocols such as IGMP, PIM-SM, PIM-DM and MSDP
	IGMP snooping
	IGMP proxy
	Fast leaving of multicast member interfaces
	Multicast traffic suppression
Reliability	Link Aggregation Control Protocol (LACP)
	STP, RSTP, VBST, and MSTP
	BPDU protection
	Smart Link and multi-instance
	Hardware-based Bidirectional Forwarding Detection (BFD)
	VRRP, VRRP load balancing, and BFD for VRRP
	BFD for BGP/IS-IS/OSPF/static route
	BFD for VXLAN
QoS	Traffic classification based on Layer 2, Layer 3, Layer 4, and priority information
	ACL, CAR, re-marking, and scheduling
	Queue scheduling modes such as PQ,DRR and PQ+DRR
	Congestion avoidance mechanisms, including WRED and tail drop
	Traffic shaping
Intelligent O&M	Network-wide path detection
	Telemetry
	ERSPAN+
	IOAM
	AnyFlow
	Intelligent traffic analysis
	Packet event
	Statistics on the buffer microburst status
	VXLAN OAM: VXLAN ping and VXLAN tracer
Intelligent and Lossless Network	PFC deadlock prevention
	AI ECN
	ECN Overlay
	intelligent Quantized Congestion Notification (iQCN)
Configuration and maintenance	Console, Telnet, and SSH terminals
	Network management protocols, such as SNMPv1/v2/v3

Item	CloudEngine 6866-48S8CQ-P
	File upload and download through FTP and TFTP BootROM upgrade and remote upgrade
	Hot patches
	User operation logs
	Zero Touch Provisioning (ZTP)
Security and management	MACsec
	Command line authority control based on user levels, preventing unauthorized users from using commands
	Defense against DoS attacks, ARP storms, and ICMP attacks
	Port isolation, port security, and sticky MAC
	Binding of the IP address, MAC address, port number, and VLAN ID
	Authentication methods, including AAA, LDAP, RADIUS, and HWTACACS
	Remote Network Monitoring (RMON)

Performance and Scalability

Item	CloudEngine 6866-48S8CQ-P
Maximum number of MAC address entries	800K
Maximum number of routes (FIB IPv4/IPv6)	1M/256K
ARP size	128K
Maximum number of VRFs	4K
IPv6 ND table size	128K
Maximum number of VRRP groups	1024
Maximum number of ECMP paths	128
Maximum number of VXLAN bridge domains	16K
Maximum number of BDIF interfaces	32K
Maximum number of virtual tunnel endpoints (VTEPs)	16K
Maximum number of LAGs	1024
Maximum number of links in a LAG	128
Maximum number of MSTIs	64
Maximum number of VLANs where VBST can be configured	1000

Note: This specification may vary between different scenarios. Please contact Huawei for details.

Hardware Specifications

Item	CloudEngine 6866-48S8CQ-P
Physical features	Dimensions (W x D x H) 442 mm x 420 mm x 43.6 mm

Item		CloudEngine 6866-48S8CQ-P
	Weight (excluding optical transceivers, power modules, and fan assemblies/including AC power modules and fan assemblies, excluding optical transceivers, kg)	6.7/8.8
	Switching capacity (Tbit/s)	8
	Forwarding performance (Mpps)	2175
10/25GE SFP28 ports		48
50GE SFP56 ports ¹		48
40/100GE QSFP28 ports		8
200GE QSFP56 ports ¹		8
Management interface	Out-of-band management port	1 x GE management interface
	Console port	1 x RJ45 interface
	USB port	1
CPU	Main frequency (GHz)	1.4
	Number of cores	4
Storage	RAM	8 GB
	NOR flash	64 MB
	NAND flash	4 GB
System	System buffer	64 MB
Power supply	Power modules	600 W AC&240 V DC 1200 W AC&240 V DC 1000 W -48 V DC 1200 W HVDC
	Rated voltage range (V)	AC: 100 V to 240 V DC: -48 V to -60 V 380 V HVDC : 240 V to 380 V
	Maximum voltage range (V)	AC: 90 V to 290 V DC: -38.4 V to -72 V 380 V HVDC: 190 V to 400 V
	Maximum input current	600 W AC power module: 100 V to 240 V 8A 600 W 240 V HVDC power module: 190 V 4A 1000 W -48 V DC power module: -48 V to -60 V 30A 1200 W 380 V HVDC power module: 190 V 8A
	Typical power	48 x 50GE + 8 x 200GE: 374 W (50% traffic load, copper cables for all ports, normal temperature, dual power modules) 48 x 25GE + 8 x 100GE: 360 W (50% traffic load, copper cables for all ports, normal temperature, dual power modules); 407 W (50% traffic

Item		CloudEngine 6866-48S8CQ-P
		load, short-distance optical modules for all ports, normal temperature, dual power modules)
	Maximum power	48 x 50GE + 8 x 200GE: 619 W (100% traffic load, all downlink ports with 2 W 50GE optical modules, all uplink ports with 6.5 W 200GE optical modules, 40°C, dual power modules) 48 x 25GE + 8 x 100GE: 544 W (100% traffic load, all downlink ports with 1.5 W 25GE optical modules, all uplink ports with 5 W 100GE optical modules, 40°C, dual power modules)
	Frequency (AC, Hz)	50/60
Heat dissipation	Heat dissipation mode	Air cooling
	Number of fan trays	4
	Heat dissipation airflow	Front-to-back or back-to-front airflow
	Maximum heat consumption (BTU/hour)	48 x 50GE + 8 x 200GE: 2110 BTU/hour (100% traffic load, all downlink ports with 2 W 50GE optical modules, all uplink ports with 6.5 W 200GE optical modules, 40°C, dual power modules) 48 x 25GE + 8 x 100GE: 1858 BTU/hour (100% traffic load, all downlink ports with 1.5 W 25GE optical modules, all uplink ports with 5 W 100GE optical modules, 40°C, dual power modules)
Environment specifications	Long-term operating temperature (°C)	0°C to 40°C (0-1800 m) The temperature decreases by 1°C each time the altitude increases by 220 m.
	Storage temperature (°C)	-40°C to +70°C
	Relative humidity	5% to 95%
	Operating altitude (m)	Up to 5000
	Sound power at 27°C (dBA)	Front-to-back airflow: < 68 Back-to-front airflow: < 67
	Sound power at 40°C (dBA)	Front-to-back airflow: < 84 Back-to-front airflow: < 83
	Sound pressure at 27°C (dBA)	Front-to-back airflow: 54 on average (maximum: 59) Back-to-front airflow: 53 on average (maximum: 58)
	Surge protection	AC power supply protection: 6 kV in common mode and 6 kV in differential mode DC power supply protection: 4 kV in common mode and 2 kV in differential mode
Reliability	MTBF (year)	30.32
	MTTR (hour)	1.5
	Availability	0.9999943515

1 By default, the 6866-48S8CQ-P supports 48*25GE SFP28 + 8*100GE QSFP28 ports. To upgrade to 48*50GE SFP56 + 8*200GE QSFP56, purchase the CE68-RTU-U48S8CQ hardware RTU.

Note: For detailed information of CloudEngine 6800 hardware information, visit <https://support.huawei.com/enterprise/en/doc/EDOC1000019246?idPath=7919710%7C21782165%7C21782239%7C22318540%7C7597815>.

Safety and Regulatory Compliance

The following table lists the safety and regulatory compliance of CloudEngine 6800 series switches.

Certification Category	Description
Safety	<ul style="list-style-type: none">• EN 60950-1• EN 60825-1• EN 60825-2• UL 60950-1• CSA-C22.2 No. 60950-1• IEC 60950-1• AS/NZS 60950-1• GB4943
Electromagnetic Compatibility (EMC)	<ul style="list-style-type: none">• EN 300386• EN 55032: CLASS A• EN 55024• IEC/EN 61000-3-2• IEC/EN 61000-3-3• FCC 47CFR Part15 CLASS A• ICES-003: CLASS A• CISPR 32: CLASS A• CISPR 24• AS/NZS CISPR32• VCCI- CISPR32: CLASS A• GB9254 CLASS A
Environment	<ul style="list-style-type: none">• 2011/65/EU EN 50581• 2012/19/EU EN 50419• (EC) No.1907/2006• GB/T 26572• ETSI EN 300 019-1-1• ETSI EN 300 019-1-2• ETSI EN 300 019-1-3• ETSI EN 300 753 GR63

Note

EMC: electromagnetic compatibility

CISPR: International Special Committee on Radio Interference

EN: European Standard

ETSI: European Telecommunications Standards Institute

CFR: Code of Federal Regulations

FCC: Federal Communication Commission

IEC: International Electrotechnical Commission

AS/NZS: Australian/New Zealand Standard

VCCI: Voluntary Control Council for Interference

UL: Underwriters Laboratories

CSA: Canadian Standards Association

Supported MIBs

For details about MIB information, visit

<http://support.huawei.com/hedex/hdx.do?docid=EDOC1100020548&lang=en&idPath=7919710%7C21782165%7C21782239%7C22318540%7C7597815>.

Optical Transceivers and Cable

For details about optical transceivers and cables, visit

<https://e.huawei.com/en/material/networking/dcs/switch/f6d91cf16df0474998087676a33fd41e>.

Ordering Information

Mainframe	
CE6866-48S8CQ-P	CE6866-48S8CQ-P switch (48*25G SFP28, 8*100G QSFP28, without fan and power modules)(CM)
CE6866-48S8CQ-PB	CE6866-48S8CQ-PB switch (48*25G SFP28, 8*100G QSFP28, 2*AC power modules, 4*fan modules, port-side intake)(CM)
CE6866-48S8CQ-PF	CE6866-48S8CQ-PF switch (48*25G SFP28, 8*100G QSFP28, 2*AC power modules, 4*fan modules, port-side exhaust)(CM)

Fan Tray

Model	Description	Applicable Product
FAN-031A-F	Fan box (F,FAN panel side intake)	CE6866-48S8CQ-P
FAN-031A-B	Fan box (B,FAN panel side exhaust)	CE6866-48S8CQ-P

Power

Model	Description	Applicable Product
PAC600S12-CF	600W AC Power Module(Front to Back,Power panel side intake)	CE6866-48S8CQ-P
PAC600S12-CB	600W AC Power Module(Back to Front, Power panel side exhaust)	CE6866-48S8CQ-P
PDC1000S12-DF	1000W DC Power Module (Front to Back,Power panel side intake)	CE6866-48S8CQ-P
PDC1000S12-DB	1000W DC Power Module (Front to Back,Power panel side exhaust)	CE6866-48S8CQ-P
PAC1K2S12-DB	1200W AC&240V DC Power Module (Back to Front, Power panel side exhaust)	CE6866-48S8CQ-P
PAC1K2S12-DF	1200W AC&240V DC Power Module (Front to Back,Power panel side intake)	CE6866-48S8CQ-P
PHD1K2S12-DB	1200W HVDC Power Module (Back to Front, Power panel side exhaust)	CE6866-48S8CQ-P

Hardware RTU

CE68-RTU-U48S8CQ	Downlink 48*25G Upgrade to 48*50G & Uplink 8*100G Upgrade to 8*200G Right-to-Use for CloudEngine 6800
------------------	---

Software

N1-CE68LIC-CFFD	N1-CloudFabric Foundation SW License for CloudEngine 6800
N1-CE68CFFD-SnS1Y	N1-CloudFabric Foundation SW License for CloudEngine 6800-SnS-1 Year
N1-CE68LIC-CFAD	N1-CloudFabric Advanced SW License for CloudEngine 6800
N1-CE68CFAD-SnS1Y	N1-CloudFabric Advanced SW License for CloudEngine -SnS -1 Year
N1-CE68LIC-CFPM	N1-CloudFabric Premium SW License for CloudEngine 6800
N1-CE68CFPM-SnS1Y	N1-CloudFabric Premium SW License for CloudEngine 6800 -SnS-Year
N1-CE68LIC-AFRD-2	N1-CloudEngine 6800 AI Fabric RDMA Application Acceleration Function 2
N1-CE68AFRD2-SnS1Y	N1-CloudEngine 6800 AI Fabric RDMA Application Acceleration Function 2-SnS-Year
N1-CE-F-LIC-MDCA	N1-CloudEngine Data Center Switch Multi-cloud Multi-DC Value-added Package - Fixed
N1-CEFMDCA -SnS1Y	N1-CloudEngine Data Center Switch Multi-cloud Multi-DC Value-added Package, Per Fixed device -SnS-Year

Networking and Application

Data Center Applications

On a typical data center network, CloudEngine 6866 switches work as TOR switches and connect to CloudEngine 16800 or CloudEngine 12800 or CloudEngine 8800 switches using 40GE/100GE/400GE ports, building an end-to-end 100GE/400GE full-mesh network. The core and TOR switches use fabric technologies such as VXLAN to build a non-blocking large Layer 2 network, which allows for large-scale VM migration and flexible service deployment.

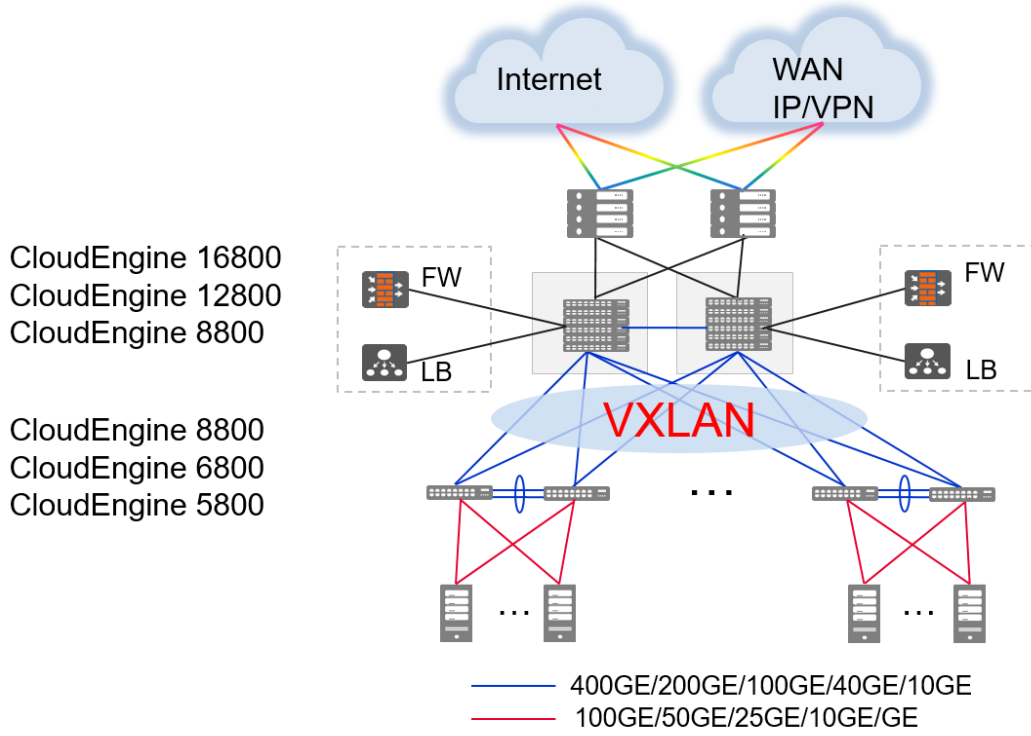

Note: VXLAN can also be used on campus networks to support flexible service deployment in different service areas.

Copyright © Huawei Technologies Co., Ltd. 2021. All rights reserved.

No part of this document may be reproduced or transmitted in any form or by any means without prior written consent of Huawei Technologies Co., Ltd.

Trademarks and Permissions



HUAWEI and other Huawei trademarks are trademarks of Huawei Technologies Co., Ltd.

All other trademarks and trade names mentioned in this document are the property of their respective holders.

Notice

The purchased products, services and features are stipulated by the contract made between Huawei and the customer. All or part of the products, services and features described in this document may not be within the purchase scope or the usage scope. Unless otherwise specified in the contract, all statements, information, and recommendations in this document are provided "AS IS" without warranties, guarantees or representations of any kind, either express or implied.

The information in this document is subject to change without notice. Every effort has been made in the preparation of this document to ensure accuracy of the contents, but all statements, information, and recommendations in this document do not constitute a warranty of any kind, express or implied.

Huawei Technologies Co., Ltd.

Address: Huawei Industrial Base Bantian, Longgang Shenzhen 518129 People's Republic of China

Website: www.huawei.com