

Overview

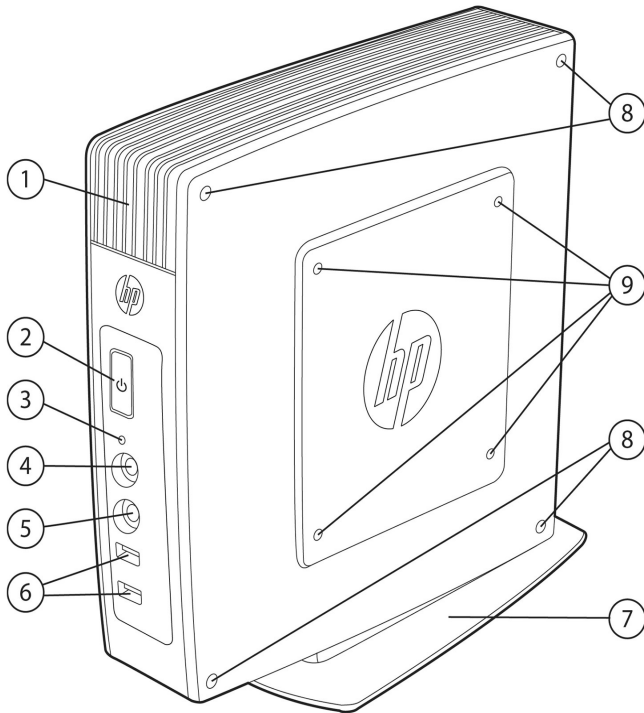

FRONT

1. Secure USB compartment (2 USB connectors)
2. Power button with LED
3. Flash storage activity indicator
4. Audio connector (mic in)
5. Audio connector (headphone out)
6. USB connectors (2)
7. Vertical stand (removable)
8. Insertion points for self-adhesive, horizontal positioning feet
9. VESA mounting points (4)

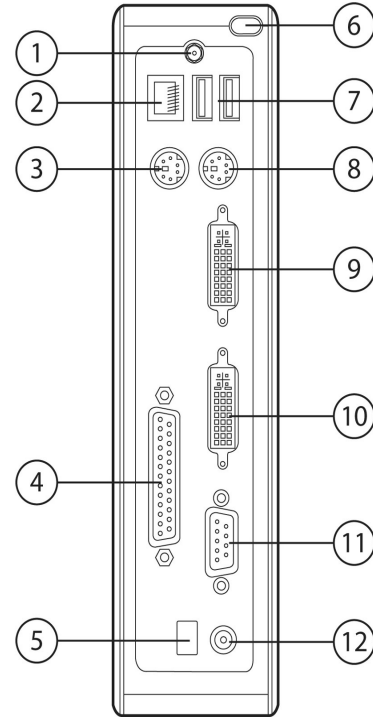

BACK

1. Integrated wireless Ethernet antenna connector (available on some models. Second antenna connector for some models)
2. 10/100/1000 Ethernet RJ-45 connector
3. PS/2 mouse connector
4. Parallel port
5. Power cord retention slot
6. Cable routing from secure USB compartment
7. USB connectors (2)
8. PS/2 keyboard connector
9. DVI-D connector
10. DVI-I connector
11. Serial Port
12. +19V DC power input

Overview

TOP

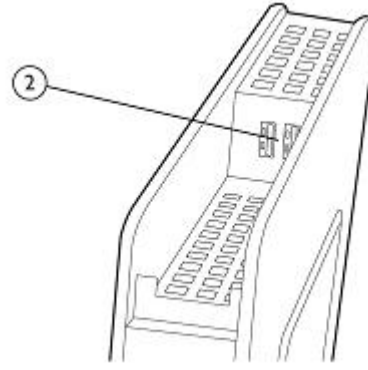
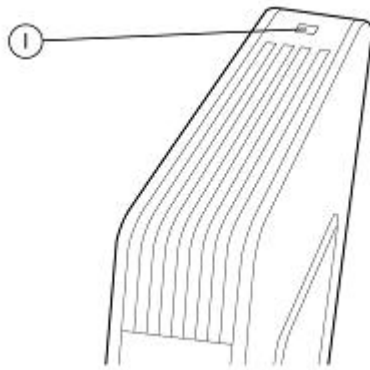

1. Cable lock slot – secures unit and secure USB compartment
2. Secure USB compartment with cover removed – 2 USB connectors

At A Glance

Hardware features:

- VIA Eden X2 U4200 (1 GHz, 2 cores) processor for great performance
- VIA VX900 chipset
- 2 GB 1066 MHz DDR3 RAM (128 MB reserved for video)
- 1, 2 or 16GB Flash memory (depending on operating system) provides ample storage for applications and drivers
- 6 USB 2.0 ports
- Secure USB compartment is ideal for protecting USB Flash devices or for securing USB keyboard and mouse
- Legacy support includes parallel, serial, and PS/2 connections
- Built-in dual digital monitor support (DVI-I and DVI-D native, with DVI-I-to-VGA adapter included in carton)
- ENERGY STAR® qualified and EPEAT® Gold registered where applicable/supported. See <http://www.epeat.net> for registration status by country.
- Low halogen
- Contains over 10% post-consumer recycled plastics (by weight)

Warranty:

- HP Total Care Warranty and Services: limited three-year hardware warranty in most regions. HP Care Pack Services extend service contracts beyond your standard warranties. For more details visit <http://www.hp.com/go/lookuptool>.

Technical Specifications

PROCESSOR / CHIPSET

VIA Eden X2 U4200 (1 GHz, 2 cores)
VIA VX900

MEMORY

	Smart Zero	ThinPro	WES 2009	WES 7	CE 6
Flash (boot drive) memory	1 GB	1 GB	2 GB	16 GB	1 GB
System memory	2 GB DDR3 1066 MHz				
System memory reserved for graphics (minimum)	128 MB				
Maximum system memory	4 GB DDR3				
Memory slots	1 SODIMM				

GRAPHICS

VIA ChromotionHD 2.0 Integrated Graphics Processor

Mode	Color depth	Refresh rate (Hz)
640 x 480	8, 16, 32 bit	60, 72, 75, 85 Hz
800 x 600	8, 16, 32 bit	60, 72, 75, 85 Hz
848 x 480	8, 16, 32 bit	60, 75, 85 Hz
1024 x 480	8, 16, 32 bit	60 Hz
1024 x 768	8, 16, 32 bit	60, 70, 72, 75, 85 Hz
1280 x 720	8, 16, 32 bit	60, 75, 85 Hz
1280 x 768	8, 16, 32 bit	60 Hz
1280 x 1024	8, 16, 32 bit	60, 75, 85 Hz
1360 x 768	8, 16, 32 bit	60 Hz
1368 x 768	8, 16, 32 bit	60, 75, 85 Hz
1400 x 1050	8, 16, 32 bit	60, 75, 85 Hz
1440 x 900	8, 16, 32 bit	60, 75, 85 Hz
1600 x 1200	8, 16, 32 bit	60, 75, 85 Hz
1680 x 1050	8, 16, 32 bit	60, 75 Hz
1920 x 1080	8, 16, 32 bit	60, 75 Hz
1920 x 1200	8, 16, 32 bit	60, 75, 85 Hz

Technical Specifications

INPUT/OUTPUT (peripheral support)

Keyboard	USB or PS/2 (varies by region)
Mouse	USB or PS/2 (varies by region)
Printer	Local and/or network printers (RDP, ICA, LPD)
Video	DVI-I & DVI-D digital video output (plus included DVI-I-to-VGA adapter)

AUDIO

Output	Internal amplified speaker 1/8-inch mini-jack, 24-bit stereo, 192 kHz sample rate
Input	1/8-inch microphone mini-jack, 20-bit stereo, 96 kHz sample rate

HARDWARE SECURITY

Security lock slot (cable lock sold separately)
Secure USB compartment with 2 USB 2.0 ports

NETWORKING

Hardware networking					
10/100/1000 Gigabit Ethernet (RJ-45), Wake on LAN (WOL), PXE, TCP/IP with DNS and DHCP					
Software networking					
	Smart Zero	ThinPro	WES 7	WES 2009	CE 6
Point-to-Point Protocol (PPP)			X	X	X
Point-to-Point over Ethernet (PPPoE)			X	X	X
Direct Connection through RS-232	X	X	X	X	X
Point-to-Point Tunneling Protocol (PPTP)	X	X	X	X	X
Layer-2 Tunneling Protocol (L2TP)	X	X	X	X	X
Server Network Time Protocol (SNTP)	X	X	X	X	X

WIRELESS LAN (select models)

Adapter	WLAN Broadcom Dragon BCM943228_802.11 a/b/g/n 2x2 PCIe HMC
Form Factor	PCI-Express Half Mini Card
Security⁷	Supports 64- and 128-bit WEP, WPA, WPA2, AES, TKIP, 802.1x authentication types EAP-TLS, EAP-TTLS, EAP-PEAP, EAP-FAST, LEAP

Technical Specifications

I/O PORTS & CONNECTORS

HP t510 Flexible Series Thin Clients

6 USB 2.0 (two in front, two in rear, two in secure USB compartment)

1 Serial

1 Parallel

2 PS/2

1 RJ-45

1 DVI-I

1 DVI-D

1 DVI-I to VGA adapter included in carton

DIMENSIONS (WxDxH)

Without stand 2.3 x 8.5 x 8.25 in (5.84 x 21.59 x 20.95 cm)

With stand 2.3 x 8.5 x 8.65 in (5.84 x 21.59 x 21.97 cm)

NOTE: Dimensions are approximate

WEIGHT – Standard Chassis

With stand 3.3 lbs (1.49 kg)

Without stand 3.2 lbs (1.45 kg)

NOTE: Weights are approximate

POWER SUPPLY

65 W

Worldwide auto-sensing 100-240 VAC, 50-60 Hz

Energy-saving automatic power-down

Surge-tolerant

Software and Operating Systems

Operating Systems

HP t510 Flexible Thin Client models are pre-configured with one of the following operating systems.

- HP ThinPro
- HP Smart Zero Technology
- Genuine Windows® Embedded Standard 7
- Genuine Windows® Embedded Standard 2009
- Windows Embedded CE 6.0

HP ThinPro & HP Smart Zero Technology Operating Systems

- HP ThinPro & HP Smart Zero are HP's purpose-built thin client operating systems built from Linux
- **HP ThinPro** offers a single console interface for dashboard visibility to all user and administrative touch points with user and administrator logins for added security, including the HP Connection Manager that can be used to quickly create server connections for end-users
 - Languages: English, French, German, Spanish, Japanese, Simplified and Traditional Chinese
- **HP Smart Zero** Clients using Smart Zero Technology boot directly into a user log-in on the server or portal for which they are configured. No local thin client user interface means the end-user can get to work without special training on the access device.

Microsoft Windows Embedded Operating Systems

- **Microsoft Windows Embedded 7 (WES7)**, based on a componentized version of Windows 7, is a solid foundation for embedded thin clients. This OS offers broad Win32 application and peripheral support as well as support for System Center Configuration Manager (SCCM) and Windows Embedded Device Manager.
- HP offers the WES 7E SKU on the HP t510 thin client
- **Microsoft Windows Embedded 2009 (WES2009)** is available for existing customers who require the familiar Windows XP User Interface.
- **Microsoft Windows Embedded CE** is a light version of Windows Embedded and offers a simple browser with limited peripheral support. Windows Embedded CE 6.0 is available on the t510.

HP Velocity

- Improved Quality of Experience for End User
- Enables IT managers to monitor network activity and optimize end-user experience
- Intelligently reduces network packet loss and retransmissions providing a better experience for the end user

HP Device Manager

- Full lifecycle management of all HP Thin Clients
- Full image capture using – File Based imaging for smallest possible image size and includes compression.
 - Can also image over 802.1X and wireless connections using image caching
- Comprehensive Settings Wizard – Allows for incremental updates and changes without having to image
- Connection Capture – Configure, test, capture and deploy connections created on thin clients
- Easy Add On Wizard – View, select and deploy all available HP Add-Ons from HP.com
- Comprehensive Device Grouping, Reporting and Asset information for best possible awareness of HP thin clients

HP Easy Tools

Software and Operating Systems

- HP Easy Setup Wizard: Guides administrators through one time setup
- HP Easy Update: Keep your software current
- HP Easy Config: Purpose your HP t510 as an optimized VDI appliance
- HP Automatic Update: Automate configuration changes and/or software updates to multiple devices
 - Note: run devices in stateless mode, or cache settings locally in persistent mode

HP ThinState

- HP ThinState: Capture your master image or settings and port to USB key or HP Automatic Update repository

HP Smart Client Services

- A set of services to simplify administration of HP thin clients running Smart Zero Technology
- Support for DHCP tags to allow HP thin client to discover the Smart Client Services and get updated with the most up-to-date settings and software
- The Profile Editor enables administrator to pre-configure connections and resources to get the Smart Clients set up. When the a thin client running Smart Zero technology boots up, it will be updated with these setting
- The auto-update capability ensures HP thin clients are up-to-date with the latest software image and configuration

HP Teem Talk emulation suite

- Access legacy application resources such as mainframes and mid-range servers or Unix/Linux X-window environments

SERVER OS COMPATIBILITY/SUPPORT

- **For WES, ThinPro, Smart Zero**
 - Citrix XenApp 5.x and 6.x
 - Citrix XenDesktop 5.x
 - Citrix Presentation Server 4.x
 - Windows Server 2003
 - Windows Server 2008r2
 - Windows Server 2012 Remote Desktop services (WES only)
 - VMware Horizon View 4.x/5.x
- **For Windows CE**
 - Citrix XenApp 5 and 6
 - Citrix XenDesktop 2.x, 3, and 4
 - Citrix Presentation Server 4.0
 - Windows Server 2008 Terminal Services
 - Windows 2000/2003 Server Terminal Services

NOTE: While the HP t510 supports Windows CE 6.0, the Windows CE 6.0 architecture does not take advantage of multi-core processors and can only utilize a maximum of 512 MB physical RAM.

SOFTWARE for HP t510:

Host Environment		Smart Zero	ThinPro	WES 7	WES 2009	CE 6
Microsoft Remote Desktop Services	RemoteFX (RFX)	✓	✓	✓		
	RDP	✓	✓	✓	✓	✓

Software and Operating Systems

Citrix	ICA	✓	✓	✓	✓	✓
	HDX	✓	✓	✓	✓	
VMware Horizon View	RDP	✓	✓	✓	✓	✓
	PCoIP	✓	✓	✓	✓	
Protocol Clients		Smart Zero	ThinPro	WES 7	WES 2009	CE 6
Citrix Receiver*		12.1.5	12.1.5	3.3 (E)	3.3 (E)	10
Citrix Online Plugin		12.1.5	12.1.5	13.3	13.3	10
Microsoft Remote Desktop Client				8	7	6
VMware Horizon View Client*		1.7	1.7	5.2	5.2	4.6 via VDM
HP TeamTalk Terminal Emulator			7.3	7.3	7.3	6.0
Free RDP		1.0	1.0			
Browser Support		Smart Zero	ThinPro	WES 7	WES 2009	CE 6
Mozilla Firefox		15	15			
Internet Explorer				9	8	6
Security		Smart Zero	ThinPro	WES 7	WES 2009	CE 6
Smart Card		✓	✓	✓	✓	✓
logon Manager				✓	✓	✓
Read Only Operating System				✓	✓	✓
802.1x		✓	✓	✓	✓	Via add-on
Enhanced Write Filter and File-Based Write Filter				✓	✓	
Microsoft Firewall				✓	✓	
Session brokers		Smart Zero	ThinPro	WES 7	WES 2009	CE 6
Citrix XenDesktop		✓	✓	✓	✓	✓
VMware Horizon View		1.7	1.7	5.2	5.2	4.6 via VDM
Leostream Desktop Connection broker (available from vendor website)				from vendor site		
Management Tools		Smart Zero	ThinPro	WES 7	WES 2009	CE 6
HP Device Manager		✓	✓	✓	✓	✓
HP ThinState			✓	✓	✓	✓
HP Easy Tools			✓	✓	✓	✓
HP Smart Client Services		✓				
Microsoft SCCM/EDM agent				✓		
Additional Components		Smart Zero	ThinPro	WES 7	WES 2009	CE 6
HP Velocity		✓	✓	✓	✓	
HP Connection Manager			✓	✓	✓	✓
HP Universal Print Driver				✓		
Windows Media Player				12	11	9
Microsoft .NET Framework				✓	✓	
Jet CET Print Professional						✓
Audio CODECs included		Smart Zero	ThinPro	WES 7	WES 2009	CE 6
MP3		✓	✓	✓	✓	✓
Microsoft AC3 Encoder		✓	✓	✓	✓	
WMA stereo		✓	✓	✓	✓	✓
Additional Components		Smart Zero	ThinPro	WES 7	WES 2009	CE 6

Software and Operating Systems

MPEG-1	✓	✓	✓	✓	✓
MPEG-4 part 2 (DivX, Xvid, H.263)	✓	✓	✓	✓	✓
MPEG-4 part 10 (H.264, AVC)	✓	✓	✓	✓	
WMV 7/8/9/ VC-1 & ASF Demuxer	✓	✓	✓	✓	

NOTE: Other add-on software available (see: www.hp.com/support for latest list of available add-ons). Software performance and support may vary depending on customer environment and backend.

*Citrix provides two versions of Citrix Receiver: Standard (S) and Enterprise (E) for Windows Embedded Standard. Please go to Citrix.com for more info. Citrix Receiver and VMware Horizon client versions vary depending on operating systems.

EMULATIONS

HP TeemTalk Terminal Emulator supports these emulations. SSH is supported in terminal emulation mode allowing users to secure their connections to the host.

Emulation	Terminal ID
ADDS Viewpoint A2	ADDS-A2
AIXTerm	Aixterm
ANSI BBS	Ansi
AT&T AT 386	at386-m
AT&T Dataspeed 4410	att4410
Bull BQ3107	VIP7700, VIP7760
Data General Dasher 410/412	dg410
Hewlett Packard HP700-92/96	2392A, 2622A, 70092, 70094, 70096
Hazeltine 1500	HZ1500
IBM 3151	11, 11-28, 31, 31-28
IBM 3270	3278-2 (24x80 Mono), 3278-3 (32x80 Mono), 3278-4 (43x80 Mono), 3278-5 (27x132 Mono), 3278-2-E (24x80 Color), 3278-3-E (32x80 Color), 3278-4-E (43x80 Color), 3278-5-E (27x132 Color), 3279-2 (24x80 Color), 3279-3 (32x80 Color), 3279-4 (43x80 Color), 3279-5 (27x132 Color), 3287-1 (Printer)
IBM 5250	3179-2 (24x80 Color), 3180-2 (27x132 Mono Msg), 3196-A1 (24x80 Mono), 3477-FC (27x132 Color Msg), 3477-FG (27x132 Mono Msg), 3486-BA (24x80 Mono), 3487-HA (27x132 Mono),

Software and Operating Systems

	3487-HC (27x132 Color), 3812-1 (Printer), 5251-11 (24x80 Mono), 5291-1 (24x80 Mono), 5292-2 (24x80 Color), 5553-B01 (DBCS Printer), 5555-B01 (DBCS 24x80 Mono), 5555-C01 (DBCS 24x80 Color)
McDonnell Douglas Prism-8, Prism-12	tty
McDonnell Douglas Prism-9	tty
Prime PT250	pt250
SCO Console	ansi
Siemens 97801	97801
Stratus V102	v102
Tandem TA6526, TA6530	tn6530-8
Televideo 910	TVI910
Televideo 920	TVI920
Televideo 925	TVI925
Televideo 950	TVI950
Televideo 955	TVI955
Unisys T27	UNISYS-TD830
Viewdata 40	VIEWDATA - 40
Viewdata 80	VIEWDATA - 80
Viewdata Split	VIEWDATA - SPLIT
DEC VT PCTerm	VT-PCTERM
DEC VT100	m2200, vt100, vt101, vt102, vt125, vt131, vt132, vt220, vt240, vt320, vt340, vt420, vt510, vt520, vt525
DEC VT100+	VT100+
DEC VT500 7-bit	m2200, vt100, vt101, vt102, vt125, vt131, vt132, vt220, vt240, vt320, vt340, vt420, vt510, vt520, vt525
DEC VT500 8-bit	m2200, vt100, vt101, vt102, vt125, vt131, vt132, vt220, vt240, vt320, vt340, vt420, vt510, vt520, vt525
DEC VT 52	m2200, vt100, vt101, vt102, vt125, vt131, vt132, vt220, vt240, vt320, vt340, vt420, vt510, vt520, vt525
VT HP220	vt220
VT UTF8	VT-UTF8
Wyse WY370	WYSE-370
Wyse WY50	WYSE-50
Wyse WY50+	WYSE-50
Wyse WY60	WYSE-60
Wyse PCTerm	WYSE-PCTERM

NOTE: Wireless features, performance and support may vary depending on environmental variables such placement, settings and firmware of your access points. Please contact your wireless vendor for support of your wireless environment.

Technical Specifications – Environmental Data

ENVIRONMENTAL

Operating temperature range	<u>Standard</u> 50° to 104° F (10° to 40° C) <u>Using Quick Release with a flat panel monitor</u> 50° to 95° F (10° to 35° C)
Non-operating temperature range	22° to 140° F (-30° to 60° C)
Humidity	<u>Condensing</u> 20% to 80% <u>Non-condensing</u> 10% to 90% non-condensing

NOTE: Specifications are at sea level with altitude derating of 1° C/300m (1.8° F/1000ft) to a maximum of 3 Km (10,000 ft), with no direct, sustained sunlight. Upper limit may be limited by the type and number of options installed.

REGULATORY COMPLIANCE

Ergonomics	German ZH1/618; EN29241-3, approved
Safety	UL 1950, CSA 950; TÜV-GS (EN60 950) approved
RF Interference	FCC Class B; CE Mark; EN55022B; VCCI

ECO-LABEL CERTIFICATIONS & DECLARATIONS

This product has received or is in the process of being certified to the following approvals and may be labeled with one or more of these markets:

- ENERGY STAR® Category B
- EPEAT® Gold registered where applicable/supported, see www.epeat.net for registration status by country
- Low halogen product

NOTE: External power supplies, power cords, cables and peripherals are not Low Halogen. Service parts obtained after purchase may not be Low Halogen.

ENERGY CONSUMPTION

	115 VAC (60Hz)	230 VAC (50Hz)	100 VAC (60Hz)
Standard Models			
Idle State:	9.8 W	9.8 W	10.80 W
Off Mode:	0.44 W	0.45 W	0.45 W

NOTE: This product is in compliance with US executive order 13221, WOL (wake on LAN) disabled. Off Mode measurements are made with WOL disabled.

NOTE: The actual power consumption at your location could vary and is dependent on many factors including but not limited to software load on the thin client, attached peripherals, and environmental factors.

HEAT DISSIPATION

Technical Specifications – Environmental Data

	115 VAC (60Hz)	230 VAC (50Hz)	100 VAC (60Hz)
Idle State:	33.44 BTU/hr	33.44 BTU/hr	33.23 BTU/hr
Off Mode:	1.50 BTU/hr	1.54 BTU/hr	1.54 BTU/hr

NOTE: Heat dissipation is calculated based on the measured watts, assuming the service level is attained for one hour

BATTERIES

This product complies with ISO standards:

- EU Directive 91/ 157/ EEC
- EU Directive 93/ 86/ EEC
- EU Directive 98/ 101/ EEC

Batteries used in the product do not contain:

- Mercury greater than 5ppm by weight
- Cadmium greater than 10ppm by weight
- Lead greater than 4000ppm by weight.
- Battery size: CR2032 (coin cell)
- Battery type: Lithium

RECYCLED MATERIAL

Product

- This product contains at least 10% recycled materials (by weight).
- This product is at least 90% (by weight) recyclable when disposed of properly at end of life.

Packaging

- The EPE foam packaging material contains at least 5% (by weight) post-consumer recycled content.
- The corrugated paper packaging materials contains at least 80% (by weight) post-consumer recycled content.
- The packaging for this product is 100% (by weight) recyclable when disposed of properly.

RoHS COMPLIANCE

Hewlett-Packard is committed to compliance with all applicable environmental laws and regulations, including the European Union Restriction of Hazardous Substances (RoHS) Directive. HP's goal is to exceed compliance obligations by meeting the requirements of the RoHS Directive on a worldwide basis. From July 1, 2006, RoHS substances will be virtually eliminated (virtually = to levels below legal limits) for all HP electronic products subject to the RoHS Directive, except where it is widely recognized that there is no technically feasible alternative (as indicated by an exemption under the EU RoHS Directive).

MATERIAL USAGE

This product does not contain any of the following substances in excess of regulatory limits (refer to the HP General Specification for the Environment at: http://www.hp.com/hpinfo/globalcitizenship/environment/supplychain/gen_specifications.html):

- Asbestos
- Certain Azo Colorants
- Certain Brominated Flame Retardants - may not be used as flame retardants in plastics

Technical Specifications – Environmental Data

- Cadmium
- Chlorinated Hydrocarbons
- Chlorinated Paraffins
- Formaldehyde
- Halogenated Diphenyl Methanes
- Lead carbonates and sulfates
- Lead and Lead compounds
- Mercuric Oxide Batteries
- Nickel - finishes must not be used on the external surface designed to be frequently handled or carried by the user.
- Ozone Depleting Substances
- Polybrominated Biphenyls (PBBs)
- Polybrominated Biphenyl Ethers (PBBEs)
- Polybrominated Biphenyl Oxides (PBBOs)
- Polychlorinated Biphenyl (PCB)
- Polychlorinated Terphenyls (PCT)
- Polyvinyl Chloride (PVC) - except for wires and cables, and certain retail packaging has been voluntarily removed from most applications.
- Radioactive Substances
- Tributyl Tin (TBT), Triphenyl Tin (TPT), Tributyl Tin Oxide (TBTO)

Packaging

HP follows these guidelines to decrease the environmental impact of product packaging:

- Eliminate the use of heavy metals such as lead, chromium, mercury and cadmium in packaging materials.
- Eliminate the use of ozone-depleting substances (ODS) in packaging materials.
- Design packaging materials for ease of disassembly.
- Maximize the use of post-consumer recycled content materials in packaging materials.
- Use readily recyclable packaging materials such as paper and corrugated materials.
- Reduce size and weight of packages to improve transportation fuel efficiency.

Plastic packaging materials are marked according to ISO 11469 and DIN 6120 standards.

End-of-life Management and Recycling

Hewlett-Packard offers end-of-life HP product return and recycling programs in many geographic areas. To recycle your product, please go to: <http://www.hp.com/recycle> or contact your nearest HP sales office. Products returned to HP will be recycled, recovered or disposed of in a responsible manner.

The EU WEEE directive (2002/95/EC) requires manufacturers to provide treatment information for each product type for use by treatment facilities. This information (product disassembly instructions) is posted on the Hewlett Packard web site at: <http://www.hp.com/go/recyclers>.

These instructions may be used by recyclers and other WEEE treatment facilities as well as HP OEM customers who integrate and re-sell HP equipment.

Hewlett-Packard Corporate Environmental Information

For more information about HP's commitment to the environment:

Technical Specifications – Environmental Data

Global Citizenship Report:

<http://www.hp.com/hpinfo/globalcitizenship/gcreport/index.html>

Eco-label certifications:

<http://www.hp.com/hpinfo/globalcitizenship/environment/productdesign/ecolabels.html>

ISO 14001 certificates:

<http://www.hp.com/hpinfo/globalcitizenship/environment/operations/envmanagement.html>

Options and Accessories (sold separately)

		Part Number
Options	HP Quick Release Kit	EM870AA
	HP Integrated Work Center Stand	LH526AA
	HP Keyed Cable Lock	BV411AA
	65 Watt External Power Supply replacement	AZ552AA
Touchscreen Display	HP L5009tm 15" Touchscreen Monitor	VK202AA
Input Devices	HP PS/2 Standard Keyboard	DT527A
	HP USB Standard Keyboard	DT528A
	HP USB CCID Smartcard Keyboard	BV813AA
	HP PS/2 2-Button Optical Mouse	EY703AA
	HP USB 2-Button Optical Scroll Mouse	DC172B
Security	Gemalto PC USB-TR Card Reader ¹	HWP117685A
	Gemalto .NET v2+ Smart Card ¹	HWP115303B HWP115647C
	SCM SCR331 USB Smart Card Reader ¹	904054
	HP Keyed Cable Lock (BFR/PVC free)	BV411AA
Care Pack Services²	9x5 Next-Business-Day Advanced Exchange - 3 Years	331653-001; U4847E ³
	9x5 Next-Business-Day On-Site Coverage - 3 Years	331655-001; U4849E ³
	Hardware Installation	331686-001; UJ865E

¹Option, drivers, warranty, and support are available directly from third party.

²Service levels and response times for HP Care Pack Services may vary depending on your geographic location. Restrictions and limitations apply. For details, visit: www.hp.com/go/carepack.

³U4847E is available in all regions; U4849E is available in Latin America and Asia-Pacific/Japan.

©Copyright 2013 Hewlett-Packard Development Company, L.P. The information contained herein is subject to change without notice and is provided "as is" without warranty of any kind. The warranties for HP products and services are set forth in the express limited warranty statements accompanying such products and services. Nothing herein should be construed as constituting an additional warranty. HP shall not be liable for technical or editorial errors or omissions contained herein. Microsoft and Windows are trademarks of the Microsoft group of companies. ENERGY STAR is a U.S. registered mark of the United States Environmental Protection Agency.