

H3C WA7500 Series Access Points

Hardware Information and Specifications

Copyright © 2025, New H3C Technologies Co., Ltd. and its licensors

All rights reserved

No part of this manual may be reproduced or transmitted in any form or by any means without prior written consent of New H3C Technologies Co., Ltd.

Trademarks

Except for the trademarks of New H3C Technologies Co., Ltd., any trademarks that may be mentioned in this document are the property of their respective owners.

Notice

The information in this document is subject to change without notice. All contents in this document, including statements, information, and recommendations, are believed to be accurate, but they are presented without warranty of any kind, express or implied. H3C shall not be liable for technical or editorial errors or omissions contained herein.

Environmental protection

This product has been designed to comply with the environmental protection requirements. The storage, use, and disposal of this product must meet the applicable national laws and regulations.

Preface

H3C WA7500 Series Access Points Hardware Information and Specifications covers the chassis views, models, technical specifications, and LEDs of the WA7500 APs.

This preface includes the following topics about the documentation:

- [Audience](#).
- [Conventions](#).
- [Documentation feedback](#).

Audience

This documentation is intended for:

- Network planners.
- Field technical support and servicing engineers.
- Network administrators working with the WA7500 APs access point.

Conventions

The following information describes the conventions used in the documentation.





Command conventions

| Convention | Description |
|------------------|--|
| Boldface | Bold text represents commands and keywords that you enter literally as shown. |
| <i>Italic</i> | <i>Italic</i> text represents arguments that you replace with actual values. |
| [] | Square brackets enclose syntax choices (keywords or arguments) that are optional. |
| { x y ... } | Braces enclose a set of required syntax choices separated by vertical bars, from which you select one. |
| [x y ...] | Square brackets enclose a set of optional syntax choices separated by vertical bars, from which you select one or none. |
| { x y ... }* | Asterisk marked braces enclose a set of required syntax choices separated by vertical bars, from which you select a minimum of one. |
| [x y ...]* | Asterisk marked square brackets enclose optional syntax choices separated by vertical bars, from which you select one choice, multiple choices, or none. |
| &<1-n> | The argument or keyword and argument combination before the ampersand (&) sign can be entered 1 to n times. |
| # | A line that starts with a pound (#) sign is comments. |













GUI conventions

| Convention | Description |
|-----------------|---|
| Boldface | Window names, button names, field names, and menu items are in Boldface. For example, the New User window opens; click OK . |
| > | Multi-level menus are separated by angle brackets. For example, File > Create > Folder . |

Symbols

| Convention | Description |
|---|--|
|  WARNING! | An alert that calls attention to important information that if not understood or followed can result in personal injury. |
|  CAUTION: | An alert that calls attention to important information that if not understood or followed can result in data loss, data corruption, or damage to hardware or software. |
|  IMPORTANT: | An alert that calls attention to essential information. |
| NOTE: | An alert that contains additional or supplementary information. |
|  TIP: | An alert that provides helpful information. |

Network topology icons

| Convention | Description |
|---|--|
|  | Represents a generic network device, such as a router, switch, or firewall. |
|  | Represents a routing-capable device, such as a router or Layer 3 switch. |
|  | Represents a generic switch, such as a Layer 2 or Layer 3 switch, or a router that supports Layer 2 forwarding and other Layer 2 features. |
|  | Represents an access controller, a unified wired-WLAN module, or the access controller engine on a unified wired-WLAN switch. |
|  | Represents an access point. |
|  | Represents a wireless terminator unit. |
|  | Represents a wireless terminator. |
|  | Represents a mesh access point. |
|  | Represents omnidirectional signals. |
|  | Represents directional signals. |
|  | Represents a security product, such as a firewall, UTM, multiservice security gateway, or load balancing device. |
|  | Represents a security module, such as a firewall, load balancing, NetStream, SSL VPN, IPS, or ACG module. |

Examples provided in this document

Examples in this document might use devices that differ from your device in hardware model, configuration, or software version. It is normal that the port numbers, sample output, screenshots, and other information in the examples differ from what you have on your device.

Documentation feedback

You can e-mail your comments about product documentation to info@h3c.com.

We appreciate your comments.

Contents

| | |
|--|----|
| Product overview | 1 |
| AP views, ports, and technical specifications | 2 |
| WA7539 | 2 |
| AP view and dimensions | 2 |
| Ports | 2 |
| Technical specifications | 3 |
| LEDs | 5 |
| LED descriptions for single-LED APs | 5 |
| LED description for the reset button | 7 |
| Transceiver modules | 9 |
| Common transceiver modules | 9 |
| Transceiver module, fiber connector, and optical fiber views | 9 |
| Technical specifications | 9 |
| Hybrid copper-fiber transceiver modules | 10 |
| Hybrid copper-fiber transceiver module and hybrid copper-fiber connector views | 10 |
| Technical specifications | 11 |
| Receive Sensitivity Values | 12 |
| WA7539 | 12 |

Product overview

The WA7500 AP series includes the following models:

Table1-1 WA7500 AP series

| Product code | Product model | Remarks |
|---------------------|----------------------|----------------|
| EWP-WA7539-FIT | WA7539 | Indoor AP |

AP views, ports, and technical specifications

WA7539

AP view and dimensions

Figure1-1 AP view



Figure1-2 AP dimensions

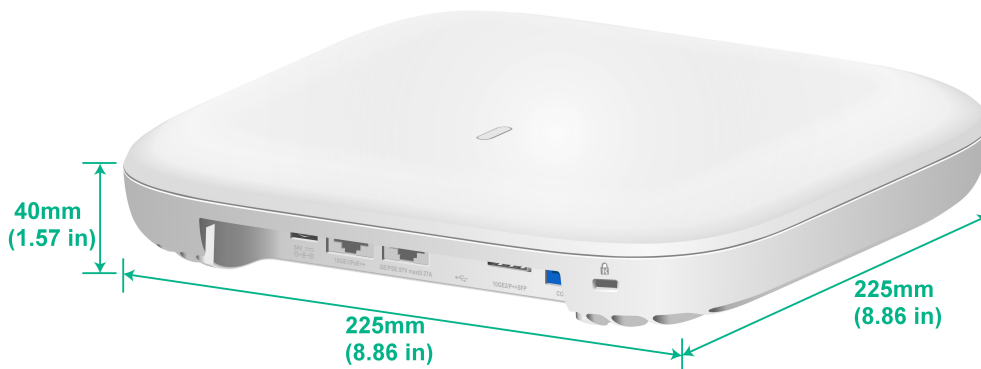

Ports

The AP provides the following ports:

- One GE/PSE port.
- One 10GE/PoE++ port.
- One 10GE/P++SFP port.
- One CONSOLE port.
- One power port.
- One USB port.

NOTE:

The AP also provides a reset button and a security slot with a size of 7 × 3 mm (0.28 × 0.12 in).

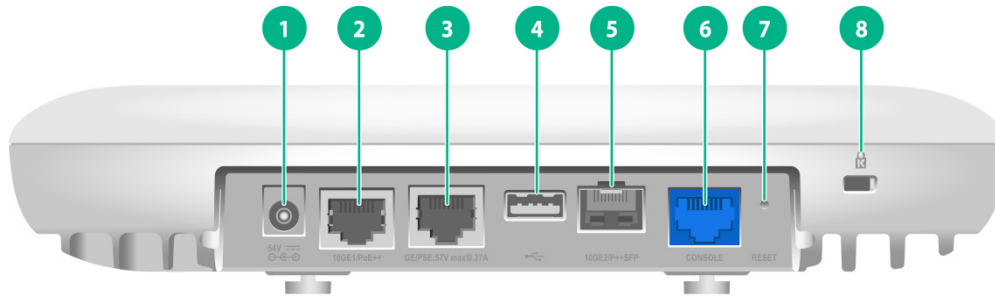
Figure1-3 Ports (1)

| | |
|-----------------------|----------------------|
| (1) Power port | (2) 10GE1/PoE++ port |
| (3) GE/PSE port | (4) USB port |
| (5) 10GE2/P++SFP port | (6) Console port |
| (7) Reset button | (8) Security slot |

Technical specifications

Table1-2 Technical specifications

| Item | Specification |
|--|--|
| Dimensions (H × W × D) (without the mounting bracket) | 40 × 225 × 225 mm (1.57 × 8.86 × 8.86 in) |
| Weight | 1.5 kg (3.31 lb) |
| Power consumption | ≤ 54 W |
| Antenna | Built-in antenna |
| Standard compliance | <ul style="list-style-type: none"> IEEE802.11a/b/g/n/ac/ax/be IEEE802.3at/bt |
| Powering option | IEEE802.3at/bt powering standard-compliant: <ul style="list-style-type: none"> Power adapter PoE PoE optical transceiver module |
| Operating temperature | 0°C to 50°C (32°F to 122°F) |
| Storage temperature | −40°C to +70°C (−40°F to +158°F) |
| Operating humidity | 5%RH to 95%RH, non-condensing |
| Storage humidity | 5%RH to 95%RH, non-condensing |
| Operating altitude | −60 m to +5000 m (−196.85 ft to +16404.20 ft) |
| Console port | Control port, used for debugging by the maintenance personnel |
| 10GE2/P++SFP port | 1000M/2.5G/5G/10G photoelectric hybrid port |
| 10GE1/PoE++ port | 100M/1000M/2.5G/5G/10G Ethernet copper port that can act as the device uplink port to connect to the Internet or MAN and as the standard PoE port at |

| Item | Specification |
|--------------------|---|
| | <p>the same time.</p> <p>When the AP operates in fit AP mode, the port is represented by interface number 10GE1/0/1 in the MAP file and Ten-GigabitEthernet 1 for configuration on the AC.</p> |
| GE/PSE port | <p>100M/1000M Ethernet copper port, used for connecting a downlink device. The AP can supply power through this port to a device with a maximum power consumption of 15 W.</p> <p>When the AP operates in fit AP mode, the port is represented by interface number GE1/0/1 in the MAP file and gigabitethernet 1 for configuration on the AC.</p> |
| USB port | <p>Compliant with USB 2.0.</p> <p>Note:</p> <p>By default, the USB port is disabled. To enable the USB port, execute the usb enable command in AP view.</p> |
| Power port (54VDC) | Used for receiving power from a local power source. |
| Reset button | The function of the reset button varies by duration for which it is pressed. For more information, see " LED description for the reset button. " |
| LEDs | Yellow/green/blue. For more information about the LED status in different AP operating modes, see " LED descriptions for single-LED APs. " |

LEDs

The description for the status LED on the AP varies by AP operating mode. For information about the operating modes supported by the AP, see the release notes.

The LED status includes the color and flashing frequency of the LEDs, which indicates the AP operating status.

The AP has only one LED.

Figure1-4 Single-LED AP(WA7539 as an example)



Table1-3 AP LEDs

| AP series | | Models | Description |
|-----------|------------------|--------|--|
| Wi-Fi 7 | WA7500 AP series | WA7539 | For the LED descriptions, see "LED descriptions for single-LED APs." |

LED descriptions for single-LED APs

LED descriptions before version changes

For the LED descriptions for the AP in versions earlier than 2615, see [Table1-4](#), [Table1-5](#), and [Table1-6](#).

Table1-4 LED description (fit mode)

| LED color | Status | Description |
|-----------|-----------------------------|--|
| N/A | Off | No power is present or the LED has been turned off from the CLI. |
| Yellow | Steady on | The AP is initializing, or an initialization exception has occurred. |
| | Flashing (twice per second) | The Ethernet ports are down and no mesh links are established. |
| Green | Steady on | The AP has started up and registered with an AC, but is in standby state (does not have any associated clients). |
| | Flashing (once every two | The AP has started up, but has not registered to any AC. |

| LED color | Status | Description |
|------------------------------------|-----------------------------|---|
| | seconds) | |
| | Flashing (twice per second) | The AP is upgrading the image. |
| Blue | Flashing (once per second) | A radio has associated clients and the number of associated clients is less than the threshold. |
| Alternating between green and blue | Flashing (once per second) | The number of associated clients has exceeded the threshold. |

Table1-5 LED description (cloud mode)

| LED color | Status | Description |
|------------------------------------|-----------------------------|--|
| N/A | Off | No power is present or the LED has been turned off from the CLI. |
| Yellow | Steady on | The AP is initializing, or an initialization exception has occurred. |
| | Flashing (twice per second) | The Ethernet ports are down and no mesh links are established. |
| Green | Steady on | The AP is in standby state, has connected to Cloudnet, but does not have any associated clients. |
| | Flashing (once per second) | The AP has connected to Cloudnet, and the radios have associated clients. The number of associated clients is less than the threshold. |
| | Flashing (twice per second) | The AP is upgrading the image. |
| Blue | Steady on | The AP is in standby state, has not connected to Cloudnet, and does not have any associated clients. |
| | Flashing (once per second) | The AP has not connected to Cloudnet, but the radios have associated clients. The number of associated clients is less than the threshold. |
| Alternating between green and blue | Flashing (once per second) | The number of associated clients has exceeded the threshold. |

Table1-6 LED description (anchor AC mode)

| LED color | Status | Description |
|-----------|-----------------------------|---|
| N/A | Off | No power is present or the LED has been turned off from the CLI. |
| Yellow | Steady on | The AP is initializing, or an initialization exception has occurred. |
| | Flashing (twice per second) | The Ethernet ports are down and no mesh links are established. |
| Green | Steady on | The AP has started up and is in standby state, but does not have any associated clients. |
| | Flashing (twice per second) | The AP is upgrading the image. |
| Blue | Flashing (once per second) | A radio has associated clients and the number of associated clients is less than the threshold. |

| LED color | Status | Description |
|------------------------------------|----------------------------|--|
| Alternating between green and blue | Flashing (once per second) | The number of associated clients has exceeded the threshold. |

LED descriptions after version changes

For the LED descriptions for the AP in 2615 and later versions, see [Table1-7](#).

Table1-7 LED description

| LED color | Status | Description |
|-----------|-----------------------------------|---|
| N/A | Off | No power is present or the LED has been turned off from the CLI. |
| Yellow | Steady on | The AP is initializing, or an initialization exception has occurred. |
| | Flashing (twice per second) | The Ethernet ports are down and no mesh links are established. |
| Green | Steady on | The AP is in standby state and does not have any associated clients. |
| | Flashing (once every two seconds) | The AP has started up in fit mode, but has not registered to any AC. |
| | Flashing (once per second) | A radio has associated clients and the number of associated clients is less than the threshold. |
| | Flashing (twice per second) | The number of associated clients has exceeded the threshold. |
| Blue | Flashing (twice per second) | The AP is upgrading the image. |

LED description for the reset button

Table1-8 LED description for the reset button

| Reset button | Press and hold duration (seconds) | LED color | Status | Description |
|--------------|-----------------------------------|-----------|-----------------------------------|--|
| RESET | 0 to 5 | Green | Steady on | Reset the AP. |
| | 5 to 20 | Green | Flashing (twice per second) | Restore to the factory defaults. |
| | 20 to 30 | Yellow | Flashing (once every two seconds) | The AP is operating in fit mode. |
| | | | Flashing (twice per second) | The AP is operating in anchor AC mode. |
| | | | Flashing (four times per second) | The AP is operating in cloud mode. |
| | > 30 | Yellow | Flashing (twice per second) | The AP is operating in anchor AC mode. |

| Reset button | Press and hold duration (seconds) | LED color | Status | Description |
|--------------|-----------------------------------|-----------|----------------------------------|---|
| | | | Flashing (four times per second) | The AP is operating in cloud mode. |
| | | Green | Flashing (four times per second) | <p>The AP is switching from fit mode to cloud mode.</p> <p>Note: After you release the button, if the AP has switched from fit mode to cloud mode, it will restart for the new mode to take effect.</p> |

Transceiver modules

Common transceiver modules

Transceiver module, fiber connector, and optical fiber views

To connect a fiber port, use an SFP transceiver module and optical fibers with LC connectors.

Figure1-5 SFP transceiver module

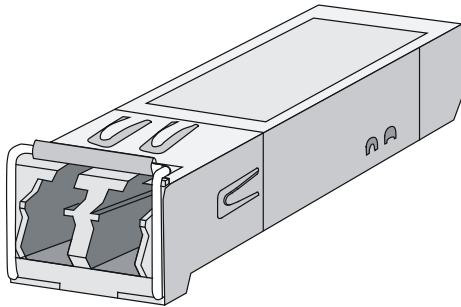
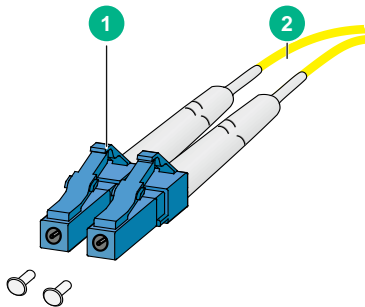

Figure1-6 Optical fiber with LC connectors



(1) LC connector

(2) Optical fiber

Technical specifications

10G transceiver module

Table1-9 SFP-XG-CPRI-IR-SM1310 transceiver module specifications

| Item | SFP-XG-CPRI-IR-SM1310 |
|-------------------------------|-----------------------|
| Central wavelength | 1310 nm |
| Maximum transmission distance | 1.4 km (0.87 miles) |
| Data rate | 4920 to 10310 Mbps |
| Connector type | LC |
| Fiber mode | SMF |

| Item | SFP-XG-CPRI-IR-SM1310 |
|------------------|-----------------------|
| Fiber diameter | 9/125 μm |
| Tx optical power | -8.2 to +0.5 dBm |

2.5G transceiver module

Table1-10 SFP-2.5G-LX10-SM1310-DR-I transceiver module specifications

| Item | SFP-2.5G-LX10-SM1310-DR-I |
|-------------------------------|---------------------------|
| Central wavelength | 1310 nm |
| Maximum transmission distance | 10 km (6.21 miles) |
| Data rate | 1228.8 to 2457.6 Mbps |
| Connector type | LC |
| Fiber mode | SMF |
| Fiber diameter | 9/125 μm |
| Tx optical power | -7 to +2 dBm |

Hybrid copper-fiber transceiver modules

Hybrid copper-fiber transceiver module and hybrid copper-fiber connector views

Hybrid copper-fiber transceiver modules support both optical and electrical transmission and PoE power supply. To connect a hybrid copper-fiber port, use a hybrid copper-fiber transceiver module and a hybrid copper-fiber cable with hybrid copper-fiber connectors.

Figure1-7 Hybrid copper-fiber transceiver module

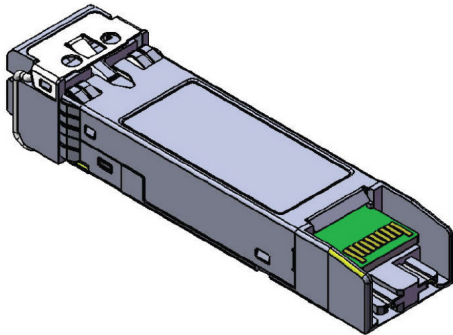
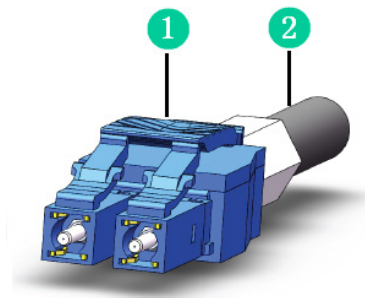

Figure1-8 Hybrid copper-fiber cable with hybrid copper-fiber connectors



(1) Hybrid copper-fiber connector

(2) Hybrid copper-fiber cable

Technical specifications

GE hybrid copper-fiber transceiver module

Table1-11 H3C-LS5M1SFPPOE-SFP GE hybrid copper-fiber transceiver module specifications

| Item | H3C-LS5M1SFPPOE-SFP |
|-------------------------------|----------------------------------|
| Operating wavelength | 1310 nm |
| Maximum transmission distance | 10 km (6.21 miles) |
| Data rate | 1.25 Gbps |
| Connector type | LC |
| Maximum power consumption | 1.0 W |
| Operating temperature range | -40°C to +85°C (-40°F to +185°F) |
| Tx optical power | -9 to -1 dBm |

10GE hybrid copper-fiber transceiver module

Table1-12 H3C-LS5M1SFPPOEA-SFP 10GE multi-rate hybrid copper-fiber transceiver module specifications

| Item | H3C-LS5M1SFPPOEA-SFP |
|-------------------------------|----------------------------------|
| Operating wavelength | 1310 nm |
| Maximum transmission distance | 1.4 km (0.87 miles) |
| Data rate | 10.3125 Gbps |
| Connector type | LC |
| Maximum power consumption | 1.2 W |
| Operating temperature range | -40°C to +85°C (-40°F to +185°F) |
| Tx optical power | -8.2 to +0.5 dBm |

Receive Sensitivity Values

Receive sensitivity is the minimum signal receive power at the antenna port required for correct wireless device operation. A lower receive sensitivity value indicates better receive performance of the wireless device.

WA7539

Table1-13 Receive Sensitivity Values

| Radio | 6GHz Radio | 5GHz Radio | 2.4GHz Radio |
|-----------------------|------------------------------|------------------------------|------------------------------|
| | Rx sensitivity (dBm) NSS1 | Rx sensitivity (dBm) NSS1 | Rx sensitivity (dBm) NSS1 |
| 802.11/11b | | | |
| 1 Mbps | - | - | -103 |
| 11 Mbps | - | - | -95 |
| 802.11a/g | | | |
| 6 Mbps | -98 | -99 | -97 |
| 24 Mbps | -89 | -89 | -90 |
| 54 Mbps | -81 | -80 | -82 |
| 802.11n HT20 | | | |
| MCS0 | - | -99 | -99 |
| MCS4 | - | -88 | -89 |
| MCS7 | - | -80 | -81 |
| 802.11n HT40 | | | |
| MCS0 | - | -96 | -96 |
| MCS4 | - | -85 | -85 |
| MCS7 | - | -77 | -78 |
| 802.11ac VHT20 | | | |
| MCS0 | - | -99 | - |
| MCS4 | - | -88 | - |
| MCS7 | - | -80 | - |
| MCS8 | - | -76 | - |
| MCS9 | - | - | - |
| 802.11ac VHT40 | | | |
| MCS0 | - | -95 | - |
| MCS4 | - | -85 | - |
| MCS7 | - | -77 | - |

| Radio | 6GHz Radio | 5GHz Radio | 2.4GHz Radio |
|------------------------|------------------------------|------------------------------|------------------------------|
| | Rx sensitivity (dBm) NSS1 | Rx sensitivity (dBm) NSS1 | Rx sensitivity (dBm) NSS1 |
| MCS8 | - | -74 | - |
| MCS9 | - | -72 | - |
| 802.11ac VHT80 | | | |
| MCS0 | - | -92 | - |
| MCS4 | - | -81 | - |
| MCS7 | - | -72 | - |
| MCS8 | - | -71 | - |
| MCS9 | - | -68 | - |
| 802.11ac VHT160 | | | |
| MCS0 | - | -91 | - |
| MCS4 | - | -80 | - |
| MCS7 | - | -72 | - |
| MCS8 | - | -69 | - |
| MCS9 | - | -67 | - |
| 802.11ax HE20 | | | |
| MCS0 | -98 | -100 | -100 |
| MCS4 | -88 | -89 | -88 |
| MCS7 | -79 | -81 | -81 |
| MCS8 | -76 | -78 | -79 |
| MCS9 | -73 | -76 | -76 |
| MCS10 | -70 | -72 | -73 |
| MCS11 | -69 | -69 | -70 |
| 802.11ax HE40 | | | |
| MCS0 | -97 | -97 | -98 |
| MCS4 | -84 | -85 | -85 |
| MCS7 | -78 | -79 | -79 |
| MCS8 | -75 | -76 | -76 |
| MCS9 | -72 | -73 | -73 |
| MCS10 | -69 | -70 | -71 |
| MCS11 | -67 | -67 | -68 |
| 802.11ax HE80 | | | |
| MCS0 | -93 | -94 | - |
| MCS4 | -82 | -83 | - |

| Radio | 6GHz Radio | 5GHz Radio | 2.4GHz Radio |
|-----------------------|------------------------------|------------------------------|------------------------------|
| | Rx sensitivity (dBm) NSS1 | Rx sensitivity (dBm) NSS1 | Rx sensitivity (dBm) NSS1 |
| MCS7 | -75 | -76 | - |
| MCS8 | -72 | -73 | - |
| MCS9 | -69 | -70 | - |
| MCS10 | -66 | -67 | - |
| MCS11 | -63 | -64 | - |
| 802.11ax HE160 | | | |
| MCS0 | -90 | -91 | - |
| MCS4 | -80 | -80 | - |
| MCS7 | -73 | -72 | - |
| MCS8 | -71 | -70 | - |
| MCS9 | -68 | -67 | - |
| MCS10 | -64 | -64 | - |
| MCS11 | -61 | -61 | - |
| 802.11be EHT20 | | | |
| MCS0 | -98 | -99 | -100 |
| MCS4 | -88 | -89 | -87 |
| MCS7 | -80 | -81 | -81 |
| MCS8 | -76 | -78 | -78 |
| MCS9 | -73 | -75 | -74 |
| MCS10 | -71 | -72 | -71 |
| MCS11 | -68 | -69 | -68 |
| MCS12 | -64 | -65 | -66 |
| MCS13 | -61 | -62 | -63 |
| 802.11be EHT40 | | | |
| MCS0 | -96 | -97 | -97 |
| MCS4 | -85 | -85 | -84 |
| MCS7 | -78 | -79 | -78 |
| MCS8 | -75 | -76 | -75 |
| MCS9 | -72 | -73 | -71 |
| MCS10 | -69 | -70 | -68 |
| MCS11 | -66 | -67 | -65 |
| MCS12 | -63 | -64 | -63 |
| MCS13 | -60 | -62 | -60 |

| Radio | 6GHz Radio | 5GHz Radio | 2.4GHz Radio |
|------------------------|------------------------------|------------------------------|------------------------------|
| | Rx sensitivity (dBm) NSS1 | Rx sensitivity (dBm) NSS1 | Rx sensitivity (dBm) NSS1 |
| 802.11be EHT80 | | | |
| MCS0 | -94 | -94 | - |
| MCS4 | -83 | -83 | - |
| MCS7 | -75 | -76 | - |
| MCS8 | -72 | -73 | - |
| MCS9 | -69 | -70 | - |
| MCS10 | -66 | -68 | - |
| MCS11 | -63 | -65 | - |
| MCS12 | -60 | -62 | - |
| MCS13 | -57 | -59 | - |
| 802.11be EHT160 | | | |
| MCS0 | -90 | -91 | - |
| MCS4 | -79 | -80 | - |
| MCS7 | -72 | -72 | - |
| MCS8 | -70 | -70 | - |
| MCS9 | -67 | -67 | - |
| MCS10 | -63 | -64 | - |
| MCS11 | -60 | -61 | - |
| MCS12 | -58 | -59 | - |
| MCS13 | -56 | -57 | - |
| 802.11be EHT320 | | | |
| MCS0 | -86 | - | - |
| MCS4 | -78 | - | - |
| MCS7 | -70 | - | - |
| MCS8 | -67 | - | - |
| MCS9 | -64 | - | - |
| MCS10 | -61 | - | - |
| MCS11 | -57 | - | - |
| MCS12 | -55 | - | - |
| MCS13 | -52 | - | - |