

# H3C WA7300 Series Access Points

## Hardware Information and Specifications

New H3C Technologies Co., Ltd.  
<http://www.h3c.com>

Document version: 6W103-20260306

**Copyright © 2026, New H3C Technologies Co., Ltd. and its licensors**

**All rights reserved**

No part of this manual may be reproduced or transmitted in any form or by any means without prior written consent of New H3C Technologies Co., Ltd.

**Trademarks**

Except for the trademarks of New H3C Technologies Co., Ltd., any trademarks that may be mentioned in this document are the property of their respective owners.

**Notice**

The information in this document is subject to change without notice. All contents in this document, including statements, information, and recommendations, are believed to be accurate, but they are presented without warranty of any kind, express or implied. H3C shall not be liable for technical or editorial errors or omissions contained herein.

**Environmental protection**

This product has been designed to comply with the environmental protection requirements. The storage, use, and disposal of this product must meet the applicable national laws and regulations.

# Preface

H3C WA7300 Series Access Points Hardware Information and Specifications covers the chassis views, models, technical specifications, and LEDs of the WA7300 APs.

This preface includes the following topics about the documentation:

- [Audience](#).
- [Conventions](#).
- [Documentation feedback](#).

## Audience

This documentation is intended for:

- Network planners.
- Field technical support and servicing engineers.
- Network administrators working with the WA7300 series access point.

## Conventions

The following information describes the conventions used in the documentation.





### Command conventions

Convention	Description
<b>Boldface</b>	<b>Bold</b> text represents commands and keywords that you enter literally as shown.
<i>Italic</i>	<i>Italic</i> text represents arguments that you replace with actual values.
[ ]	Square brackets enclose syntax choices (keywords or arguments) that are optional.
{ x   y   ... }	Braces enclose a set of required syntax choices separated by vertical bars, from which you select one.
[ x   y   ... ]	Square brackets enclose a set of optional syntax choices separated by vertical bars, from which you select one or none.
{ x   y   ... }*	Asterisk marked braces enclose a set of required syntax choices separated by vertical bars, from which you select a minimum of one.
[ x   y   ... ]*	Asterisk marked square brackets enclose optional syntax choices separated by vertical bars, from which you select one choice, multiple choices, or none.
&<1-n>	The argument or keyword and argument combination before the ampersand (&) sign can be entered 1 to n times.
#	A line that starts with a pound (#) sign is comments.













### GUI conventions

Convention	Description
<b>Boldface</b>	Window names, button names, field names, and menu items are in Boldface. For example, the <b>New User</b> window opens; click <b>OK</b> .
>	Multi-level menus are separated by angle brackets. For example, <b>File &gt; Create &gt; Folder</b> .

## Symbols

Convention	Description
 <b>WARNING!</b>	An alert that calls attention to important information that if not understood or followed can result in personal injury.
 <b>CAUTION:</b>	An alert that calls attention to important information that if not understood or followed can result in data loss, data corruption, or damage to hardware or software.
 <b>IMPORTANT:</b>	An alert that calls attention to essential information.
<b>NOTE:</b>	An alert that contains additional or supplementary information.
 <b>TIP:</b>	An alert that provides helpful information.

## Network topology icons

Convention	Description
	Represents a generic network device, such as a router, switch, or firewall.
	Represents a routing-capable device, such as a router or Layer 3 switch.
	Represents a generic switch, such as a Layer 2 or Layer 3 switch, or a router that supports Layer 2 forwarding and other Layer 2 features.
	Represents an access controller, a unified wired-WLAN module, or the access controller engine on a unified wired-WLAN switch.
	Represents an access point.
	Represents a wireless terminator unit.
	Represents a wireless terminator.
	Represents a mesh access point.
	Represents omnidirectional signals.
	Represents directional signals.
	Represents a security product, such as a firewall, UTM, multiservice security gateway, or load balancing device.
	Represents a security module, such as a firewall, load balancing, NetStream, SSL VPN, IPS, or ACG module.

## Examples provided in this document

Examples in this document might use devices that differ from your device in hardware model, configuration, or software version. It is normal that the port numbers, sample output, screenshots, and other information in the examples differ from what you have on your device.

# Documentation feedback

You can e-mail your comments about product documentation to [info@h3c.com](mailto:info@h3c.com).

We appreciate your comments.

# Contents

Product overview .....	1
AP views, ports, and technical specifications .....	2
WA7320 .....	2
AP view and dimensions .....	2
Ports .....	2
Technical specifications .....	3
WA7320H-HI .....	5
AP view and dimensions .....	5
Ports .....	5
Technical specifications .....	7
WA7320i .....	8
AP view and dimensions .....	8
Ports .....	9
Technical specifications .....	10
WA7320XE .....	11
AP view and dimensions .....	11
Ports .....	11
Technical specifications .....	12
WA7322H-HI .....	14
AP view and dimensions .....	14
Ports .....	14
Technical specifications .....	16
WA7330i .....	17
AP view and dimensions .....	17
Ports .....	18
Technical specifications .....	19
WA7330X .....	20
AP view and dimensions .....	20
Ports .....	21
Technical specifications .....	22
WA7338-HI .....	23
AP view and dimensions .....	23
Ports .....	23
Technical specifications .....	24
<b>LEDs .....</b>	<b>26</b>
AP LEDs .....	26
LED descriptions for single-LED APs .....	26
LED description for the reset button .....	28
<b>Transceiver modules .....</b>	<b>30</b>
Common transceiver modules .....	30
Transceiver module, fiber connector, and optical fiber views .....	30
Technical specifications .....	30
Hybrid copper-fiber transceiver modules .....	32
Hybrid copper-fiber transceiver module and hybrid copper-fiber connector views .....	32
Technical specifications .....	33
<b>Receive Sensitivity Values .....</b>	<b>35</b>
WA7320 .....	35
WA7320i .....	38
WA7320XE .....	42
WA7320H-HI .....	46
WA7330i .....	50
WA7330X .....	54
WA7338-HI .....	58

# Product overview

The WA7300 AP series includes the following models:

**Table1-1 WA7300 AP series**

Product code	Product model	Remarks
EWP-WA7320-FIT	WA7320	Indoor AP
EWP-WA7320i-FIT	WA7320i	
EWP-WA7330i-FIT	WA7330i	
EWP-WA7338-HI-FIT	WA7338-HI	
EWP-WA7320H-HI-FIT	WA7320H-HI	Walljack AP
EWP-WA7322H-HI-FIT	WA7322H-HI	
EWP-WA7320XE-FIT	WA7320XE	Outdoor AP
EWP-WA7330X-FIT	WA7330X	

# AP views, ports, and technical specifications

## WA7320

### AP view and dimensions

#### AP view

Figure1-2 AP view



#### AP dimensions

Figure1-3 AP dimensions



### Ports

The AP provides the following ports:

- One 5GE/P+SFP fiber port.
- One local power port.
- One 2.5GE/PoE+ copper Ethernet port.

- One GE copper port.
- One console port.
- One USB port.

**NOTE:**

The AP also provides a reset button and a security slot with a size of 7 × 3 mm (0.28 × 0.12 in).

**Figure1-4 Ports (1)**

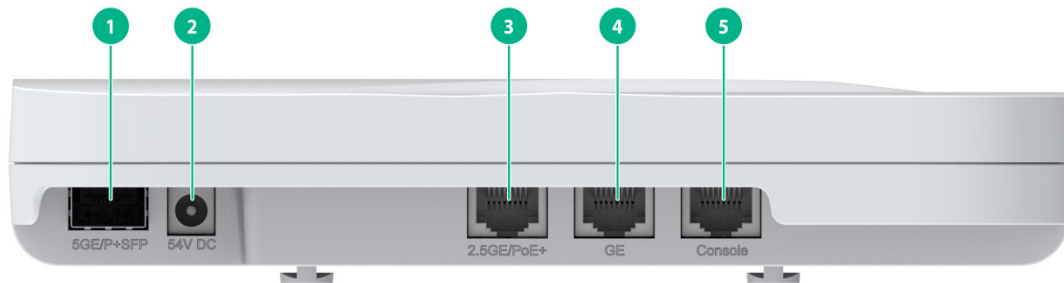

(1) 5GE/P+SFP fiber port	(2) Local power port	(3) 2.5GE/PoE+ copper Ethernet port
(4) GE copper port	(5) Console port	

**Figure1-5 Ports (2)**

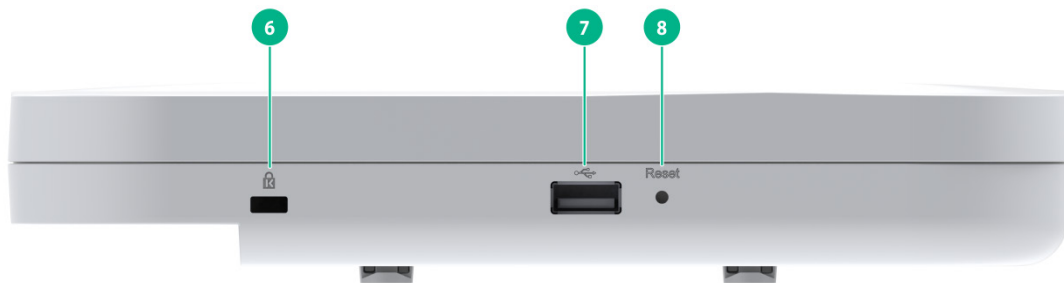

(6) Security slot	(7) USB port	(8) Reset button
-------------------	--------------	------------------

## Technical specifications

**Table1-2 Technical specifications**

Item	Description
Dimensions (H × W × D)	35 × 205 × 205 mm (1.38 × 8.07 × 8.07 in, excluding the mounting bracket)
Weight	0.8 kg (1.76 lb)
Power consumption	18.5 W
Antenna	Built-in antenna
Standard compliance	<ul style="list-style-type: none"> <li>• IEEE802.11a/b/g/n/ac/ax/be</li> <li>• IEEE802.3at</li> </ul>
Powering option	IEEE802.3at powering standard-compliant: <ul style="list-style-type: none"> <li>• Power adapter</li> </ul>

Item	Description
	<ul style="list-style-type: none"> <li>PoE</li> <li>Hybrid copper-fiber transceiver module</li> </ul>
Operating temperature	-10°C to +50°C (14°F to 122°F)
Storage temperature	-40°C to +70°C (-40°F to +158°F)
Operating humidity	5% RH to 95% RH, noncondensing
Storage humidity	5% RH to 95% RH, noncondensing
Operating altitude	-60 m to +5000 m (-196.85 ft to +16404.20 ft)
Console port	Used by technical personnel only for device configuration and management.
5GE/P+SFP	<p>100M/1000M/2.5G/5G hybrid copper-fiber port.</p> <p>When the AP operates in fit AP mode, the port is represented by interface number SGE1/0/2 in the MAP file and Smartrate-Ethernet 2 for configuration on the AC.</p>
2.5GE/PoE+	<p>100M/1000M/2.5G copper Ethernet port, used for connecting the AP to an uplink device for Internet or MAN access. It can also act as a standard PoE port.</p> <p>When the AP operates in fit AP mode, the port is represented by interface number SGE1/0/1 in the MAP file and Smartrate-Ethernet 1 for configuration on the AC.</p>
GE	<p>100M/1000M copper Ethernet port, used for connecting a downlink device. The AP can supply power through this port to a standard PD with a maximum power consumption of 15 W.</p> <p>When the AP operates in fit AP mode, the port is represented by interface number GE1/0/1 in the MAP file and GigabitEthernet 1 for configuration on the AC.</p>
USB port	<p>Compliant with USB 2.0.</p> <p>Note:</p> <p>By default, the USB port is disabled. To enable the USB port, execute the <b>usb enable</b> command in AP view.</p>
Power port (54 VDC)	Used for receiving power from a local power source.
Reset button	The function of the reset button varies by duration for which it is pressed. For more information, see " <a href="#">LED description for the reset button.</a> "
LEDs	Yellow/green/blue. For more information about the LED status in different AP operating modes, see " <a href="#">LED descriptions for single-LED APs.</a> "

# WA7320H-HI

## AP view and dimensions

### AP view

Figure1-6 AP view



### AP dimensions

Figure1-7 AP dimensions

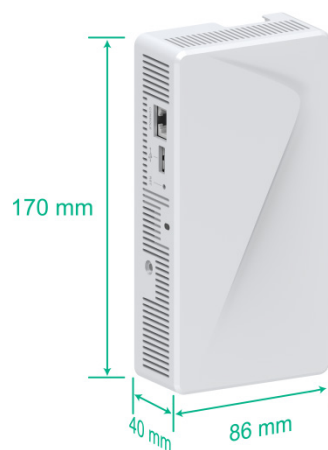

## Ports

The AP provides the following ports:

- One 2.5GE/PoE+ copper Ethernet port.
- One 5GE/SFP fiber port.
- Five copper Ethernet ports.
- One console port.

- One 54 VDC power receptacle.
- One USB port.

---

**NOTE:**

The AP also provides a reset button and a security slot with a size of 7 × 3 mm (0.28 × 0.12 in).

---

**Figure1-8 Ports (1)**

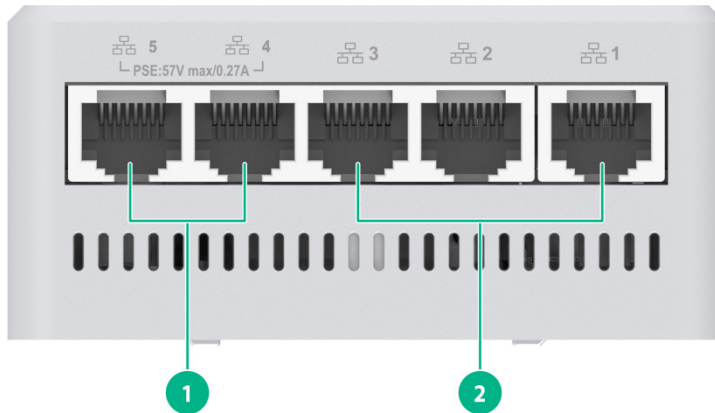

---

(1) to (2): Copper Ethernet ports

---

**Figure1-9 Ports (2)**

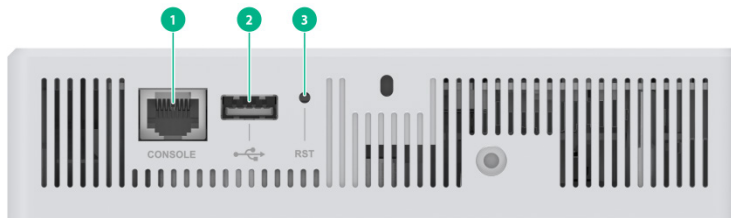

---

(1) Console port

(2) USB port

---

(3) Reset button

---

**Figure1-10 Ports (3)**

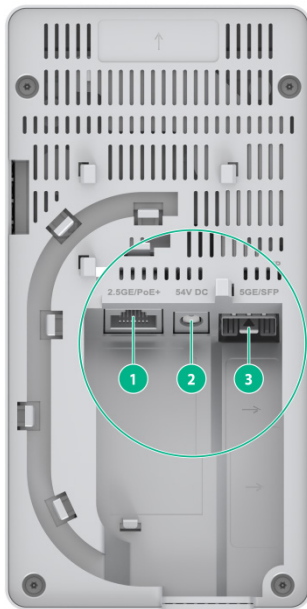

(1) 2.5GE/PoE+ copper Ethernet port

(2) 54 VDC power receptacle

(3) 5GE/SFP fiber port

## Technical specifications

**Table1-3 Technical specifications**

Item	Description
Dimensions (H x W x D)	40 x 170 x 86 mm (1.57 x 6.69 x 3.39 in, excluding the mounting bracket)
Weight	0.32 kg (0.71 lb)
Power consumption	≤30.6W
Powering option	IEEE802.3at/af powering standard-compliant: <ul style="list-style-type: none"> <li>• Power adapter</li> <li>• PoE</li> </ul>
Antenna	Built-in antenna
Standard compliance	<ul style="list-style-type: none"> <li>• IEEE802.11a/b/g/n/ac/ax/be</li> <li>• IEEE802.3at/af</li> </ul>
Operating temperature	0°C to 40°C (32°F to 104°F)
Storage temperature	-40°C to +70°C (-40°F to +158°F)
Operating humidity	5% RH to 95% RH, noncondensing
Storage humidity	5% RH to 95% RH, noncondensing
Operating altitude	-60 m to +5000 m (-196.85 ft to +16404.20 ft)
Console port	Used by technical personnel only for device configuration and management.
Copper Ethernet port	10M/100M/1000M copper Ethernet port, When the AP operates in fit mode, the ports are represented by interface

Item	Description
	numbers GE1/0/1 to GE1/0/5 in the MAP file and GigabitEthernet 1 to GigabitEthernet 5 on the AC. GE1/0/4 and GE1/0/5 support standard PSE compliant with 802.3af, and the total output power of the two ports does not exceed 15 W.
2.5GE/PoE+	100M/1000M/2.5G copper Ethernet port, used for connecting the AP to an uplink device for Internet or MAN access. It can also act as a standard PoE port. When the AP operates in fit AP mode, the port is represented by interface number SGE1/0/1 in the MAP file and Smartrate-Ethernet 1 for configuration on the AC.
5GE/SFP	100M/1000M/2.5G/5G Ethernet fiber port.
USB port	Compliant with USB 3.0. Note: By default, the USB port is disabled. To enable the USB port, execute the <b>usb enable</b> command in AP view.
Power port (54 VDC)	Used for receiving power from a local power source.
Reset button	The function of the reset button varies by duration for which it is pressed. For more information, see " <a href="#">LED description for the reset button.</a> "
LEDs	Yellow/green/blue. For more information about the LED status in different AP operating modes, see " <a href="#">LED descriptions for single-LED APs.</a> "

## WA7320i

### AP view and dimensions

#### AP view

Figure1-11 AP view



## AP dimensions

Figure1-12 AP dimensions



## Ports

The AP provides the following ports:

- One GE/PSE copper Ethernet port.
- One 10GE/PoE+ copper Ethernet port.
- One 10GE/P+SFP fiber port.
- One console port.
- One 54 VDC power port.
- One USB port.

---

### NOTE:

The AP also provides a reset button and a security slot with a size of 7 × 3 mm (0.28 × 0.12 in).

---

Figure1-13 Ports (1)

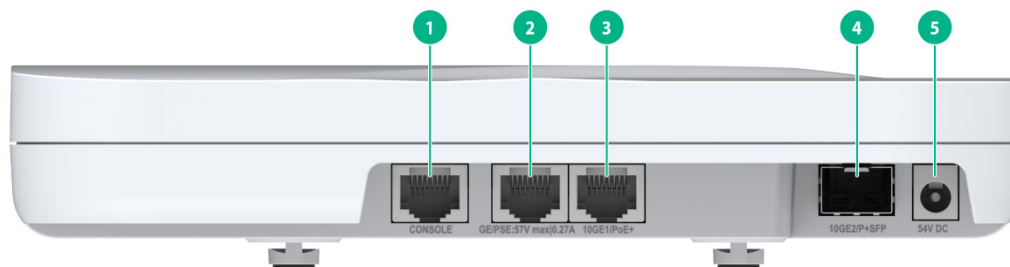

- 
- |                      |                       |                     |
|----------------------|-----------------------|---------------------|
| (1) Console port     | (2) GE/PSE port       | (3) 10GE1/PoE+ port |
| (4) 10GE2/P+SFP port | (5) 54 VDC power port |                     |
- 

Figure1-14 Ports (2)



---

(1) USB port

(2) Reset button

(3) Security slot

---

## Technical specifications

**Table1-4 Technical specifications**

Item	Description
Dimensions (H x W x D)	35 x 205 x 205 mm (1.38 x 8.07 x 8.07 in, excluding the mounting bracket)
Weight	0.8 kg (1.76 lb)
Power consumption	35.6 W
Antenna	Built-in antenna
Standard compliance	<ul style="list-style-type: none"><li>IEEE802.11a/b/g/n/ac/ax/be</li><li>IEEE802.3at/af</li></ul>
Powering option	IEEE802.3at/af powering standard-compliant: <ul style="list-style-type: none"><li>Power adapter</li><li>PoE</li><li>Hybrid copper-fiber transceiver module</li></ul>
Operating temperature	-10°C to +50°C (14°F to 122°F)
Storage temperature	-40°C to +70°C (-40°F to +158°F)
Operating humidity	5% RH to 95% RH, noncondensing
Storage humidity	5% RH to 95% RH, noncondensing
Operating altitude	-60 m to +5000 m (-196.85 ft to +16404.20 ft)
Console port	Used by technical personnel only for device configuration and management.
10GE2/P+SFP	100M/1000M/2.5G/5G/10G hybrid copper-fiber port. When the AP operates in fit AP mode, the port is represented by interface number SGE1/0/2 in the MAP file and SmartRate-Ethernet 2 for configuration on the AC.
10GE1/PoE+	100M/1000M/2.5G/5G/10G copper Ethernet port, used for connecting the AP to an uplink device for Internet or MAN access. It can also act as a standard PoE port. When the AP operates in fit AP mode, the port is represented by interface number 10GE1/0/1 in the MAP file and Ten-GigabitEthernet 1 for configuration on the AC.
GE/PSE	100M/1000M copper Ethernet port, used for connecting a downlink device. The AP can supply power through this port to a standard PD with a maximum power consumption of 15 W. When the AP operates in fit AP mode, the port is represented by interface number GE1/0/1 in the MAP file and GigabitEthernet 1/ 0/1 for configuration on the AC.
USB port	Compliant with USB 2.0. Note: By default, the USB port is disabled. To enable the USB port, execute the <b>usb enable</b> command in AP view.
Power port (54 VDC)	Used for receiving power from a local power source.
Reset button	The function of the reset button varies by duration for which it is pressed. For more information, see " <a href="#">LED description for the reset button.</a> "

Item	Description
LEDs	Yellow/green/blue. For more information about the LED status in different AP operating modes, see " <a href="#">LED descriptions for single-LED APs.</a> "

# WA7320XE

## AP view and dimensions

### AP view

Figure1-15 AP view



### AP dimensions

Figure1-16 AP dimensions

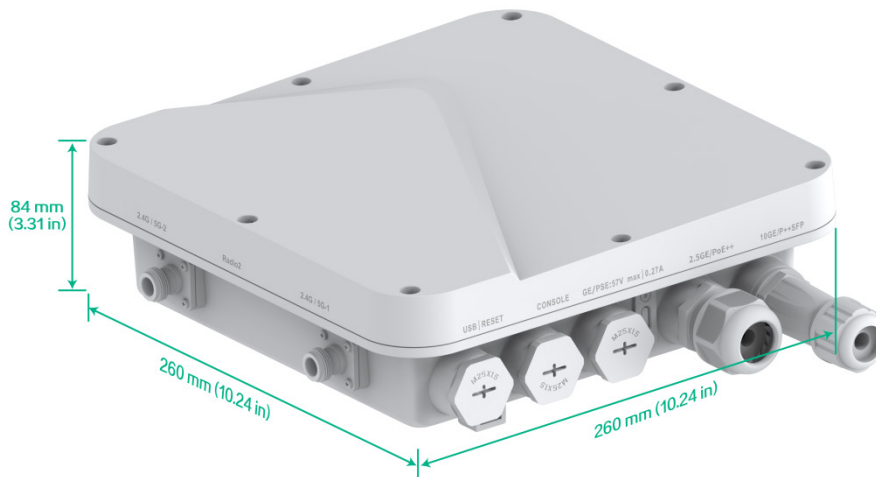

## Ports

The AP provides the following ports:

- One 2.5GE/PoE++ port.

- One 10GE/P++SFP port.
- One GE/PSE port.
- One console port
- One USB port.

**NOTE:**

The AP also provides a reset button.

**Figure1-17 Ports (1)**

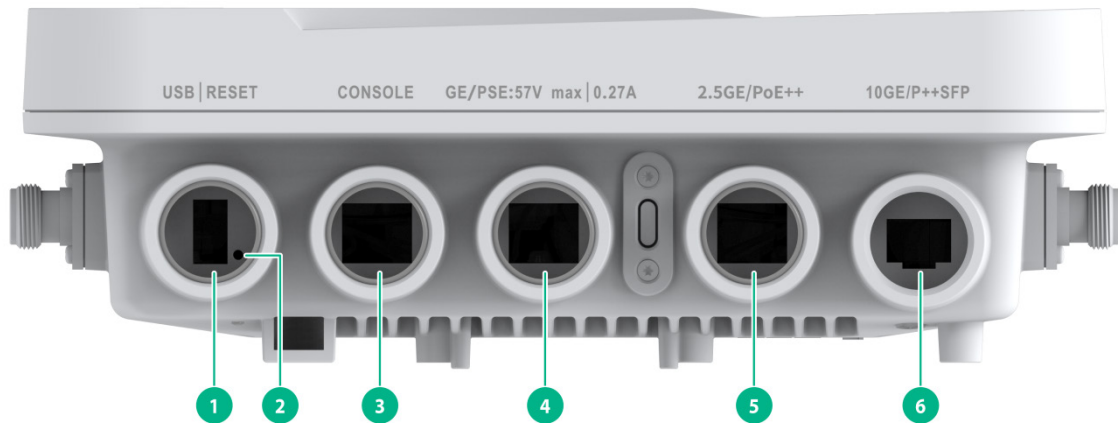

(1) USB port	(2) Reset button
(3) Console port	(4) GE/PSE port
(5) 2.5GE/PoE++ port	(6) 10GE/P++SFP port

## Technical specifications

**Table1-5 Technical specifications**

Item	Description
Dimensions (H x W x D)	84 x 260 x 260 mm (3.31 x 10.24 x 10.24 in)
Weight	2.05 kg (4.52 lb)
Power consumption	38.6 W
Antenna	External antenna
Standard compliance	<ul style="list-style-type: none"> <li>• IEEE802.11a/b/g/n/ac/ax/be</li> <li>• IEEE802.3at/af</li> </ul>
Powering option	IEEE802.3at/af powering standard-compliant: <ul style="list-style-type: none"> <li>• Power adapter</li> <li>• PoE</li> <li>• Hybrid copper-fiber transceiver module</li> </ul>
Operating temperature	-40°C to +65°C (-40°F to +149°F)
Storage temperature	-40°C to +85°C (-40°F to +185°F)
Operating humidity	0% RH to 100% RH, noncondensing
Storage humidity	0% RH to 100% RH, noncondensing

Item	Description
Operating altitude	–60 m to +5000 m (–196.85 ft to +16404.20 ft)
IP rating	IP68
Console port	Used by technical personnel only for device configuration and management.
2.5GE/PoE++	<p>100M/1000M/2.5G copper Ethernet port, used for connecting the device to an uplink device for Internet or MAN access. It can also act as a standard PoE port.</p> <p>When the AP operates in fit AP mode, the port is represented by interface number SGE1/0/1 in the MAP file and Smartrate-Ethernet 1 for configuration on the AC.</p>
10GE/P++SFP	<p>1000M/2.5G/5G/10G hybrid copper-fiber port.</p> <p>When the AP operates in fit AP mode, the port is represented by interface number XGE1/0/1 in the MAP file and Ten-GigabitEthernet 1 for configuration on the AC.</p>
GE/PSE	<p>100M/1000M copper Ethernet port, used for connecting a downlink device. The AP can supply power through this port to a standard PD with a maximum power consumption of 15 W.</p> <p>When the AP operates in fit AP mode, the port is represented by interface number GE1/0/1 in the MAP file and GigabitEthernet 1/0/1 for configuration on the AC.</p>
USB port	<p>Compliant with USB 2.0.</p> <p>Note: By default, the USB port is disabled. To enable the USB port, execute the <b>usb enable</b> command in AP view.</p>
Reset button	The function of the reset button varies by duration for which it is pressed. For more information, see " <a href="#">LED description for the reset button.</a> "
LEDs	Yellow/green/blue. For more information about the LED status in different AP operating modes, see " <a href="#">LED descriptions for single-LED APs.</a> "

# WA7322H-HI

## AP view and dimensions

### AP view

Figure1-18 AP view



### AP dimensions

Figure1-19 AP dimensions

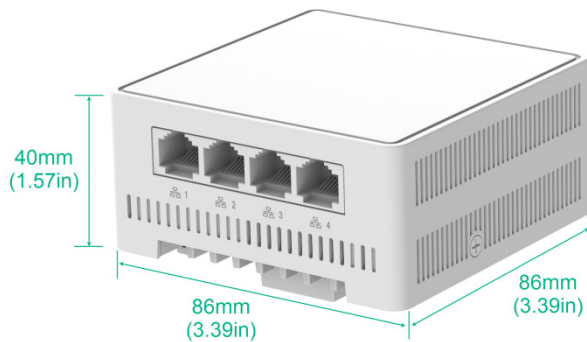

## Ports

The AP provides the following ports:

- One console port
- Four copper Ethernet ports.
- One Uplink/PoE port.
- One USB port.

---

**NOTE:**

The AP also provides a reset button.

---

**Figure1-20 Ports (1)**

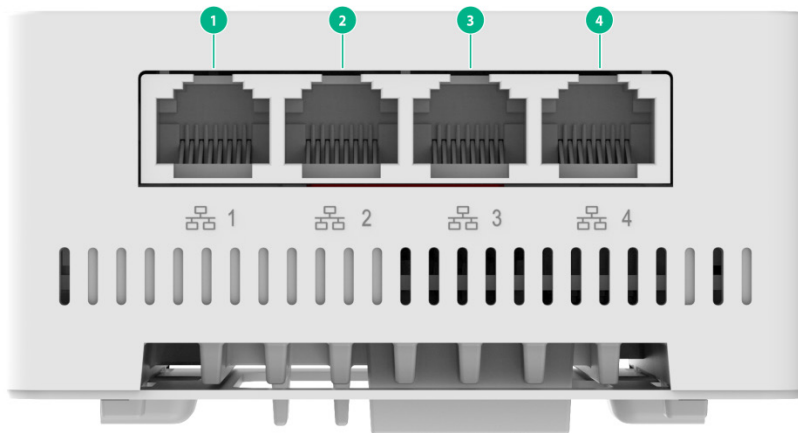

---

(1) to (4): Copper Ethernet ports

---

**Figure1-21 Ports (2)**

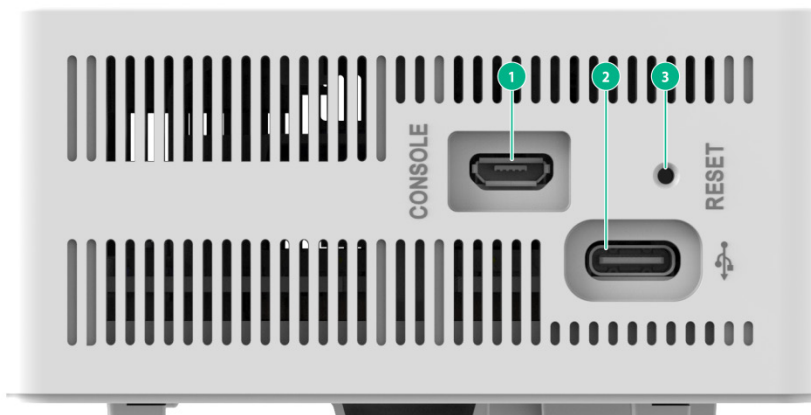

---

(1) Console port

(2) USB port

(3) Reset button

---

Figure1-22 Ports (3)

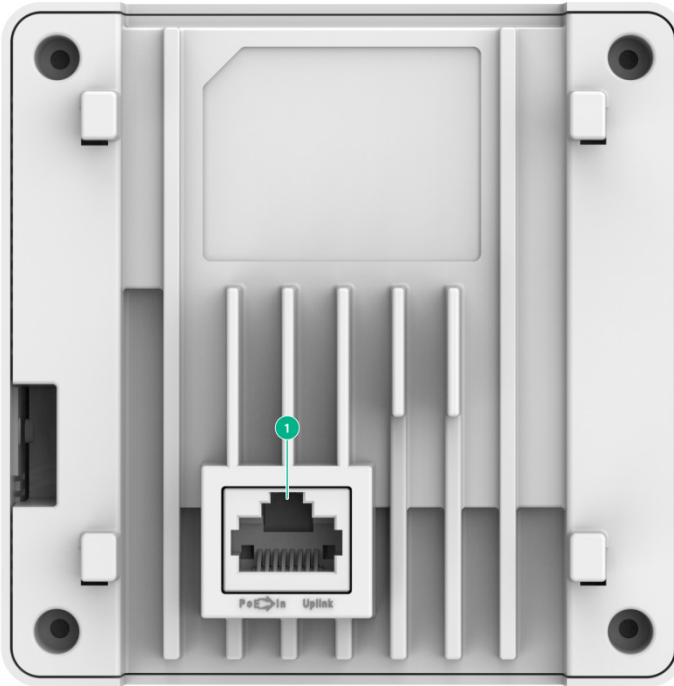

---

(1) Uplink/PoE port

---

## Technical specifications

Table1-6 Technical specifications

Item	Description
Dimensions (H x W x D)	40 x 86 x 86 mm (1.57 x 3.39 x 3.39 in, excluding the mounting bracket)
Weight	0.26 kg (0.57 lb)
Overall power consumption	15 W
Powering option	IEEE802.3bt/at powering standard-compliant: PoE
Antenna	Built-in antenna: <ul style="list-style-type: none"><li>• 2.4G: 4.0 dBi gain</li><li>• 5G: 5.0 dBi gain</li><li>• 6G: 5.2 dBi gain</li></ul>
Standard compliance	<ul style="list-style-type: none"><li>• IEEE802.11a/b/g/n/ac/ax/be</li><li>• IEEE802.3bt/at</li></ul>
Operating temperature	0°C to 40°C (32°F to 104°F)
Operating humidity	5% RH to 95% RH, noncondensing
Storage humidity	5% RH to 95% RH, noncondensing
Operating altitude	-60 m to +5000 m (-196.85 ft to +16404.20 ft)
Console port	Used by technical personnel only for device configuration and management.
Copper Ethernet port	10M/100M/1000M copper Ethernet ports, represented by interface number GE1/0/1 to GE1/0/4 in the MAP file.

Item	Description
	When the AP operates in fit AP mode, the ports are represented by interface numbers GigabitEthernet 1 to GigabitEthernet 4 for configuration on the AC.
Uplink/PoE	100M/1000M/2500M copper Ethernet port, used for connecting the device to an uplink device for Internet or MAN access. It can also act as a standard PoE port. When the AP operates in fit AP mode, the port is represented by interface number SGE1/0/1 in the MAP file and Smartrate-Ethernet 1 for configuration on the AC.
USB port	Compliant with USB 2.0. Note: By default, the USB port is disabled. To enable the USB port, execute the <b>usb enable</b> command in AP view.
Reset button	The function of the reset button varies by duration for which it is pressed. For more information, see " <a href="#">LED description for the reset button.</a> "
LEDs	Yellow/green/blue. For more information about the LED status in different AP operating modes, see " <a href="#">LED descriptions for single-LED APs.</a> "

## WA7330i

### AP view and dimensions

#### AP view

Figure1-23 AP view



## AP dimensions

Figure1-24 AP dimensions



## Ports

The AP provides the following ports:

- One 2.5GE/PSE copper Ethernet port.
- One 10GE/PoE++ copper Ethernet port.
- One 10GE/P++SFP fiber port.
- One console port.
- One 54 VDC power port.
- One USB port.

---

### NOTE:

The AP also provides a reset button and a security slot with a size of 7 × 3 mm (0.28 × 0.12 in).

---

Figure1-25 Ports (1)

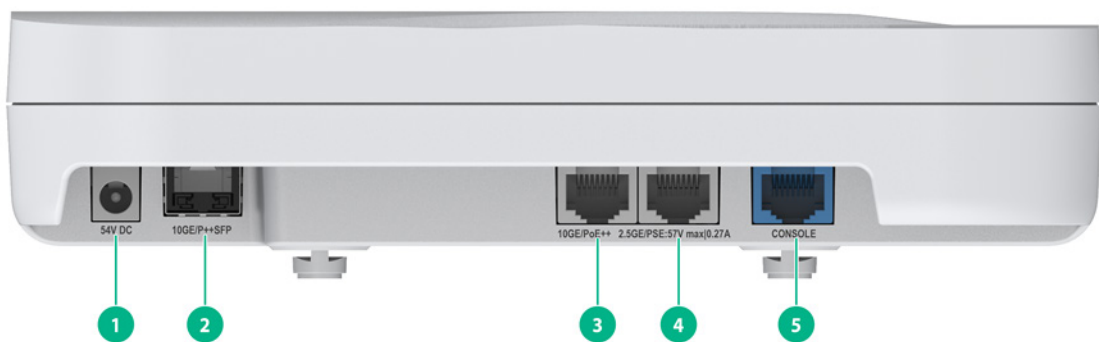

---

(1) 54 VDC power port

(2) 10GE/P++SFP port

(3) 10GE/PoE++ port

(4) 2.5GE/PSE port

(5) Console port

---

**Figure1-26 Ports (2)**

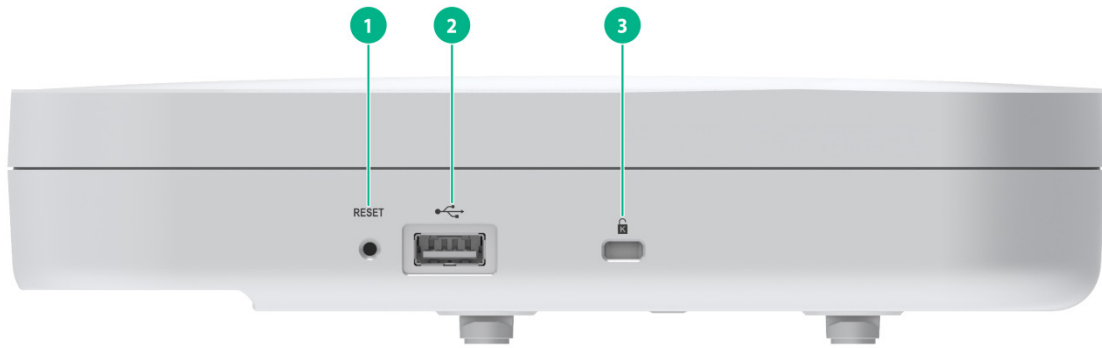

(1) Reset button

(2) USB port

(3) Security slot

## Technical specifications

**Table1-7 Technical specifications**

Item	Description
Dimensions (H x W x D)	45 x 210 x 210 mm (1.77 x 8.27 x 8.27, excluding the mounting bracket)
Weight	1 kg (2.20 lb)
Power consumption	42.12 W
Antenna	Built-in antenna
Standard compliance	<ul style="list-style-type: none"> <li>IEEE802.11a/b/g/n/ac/ax/be</li> <li>IEEE802.3bt/at</li> </ul>
Powering option	IEEE802.3bt/at powering standard-compliant: <ul style="list-style-type: none"> <li>Power adapter</li> <li>PoE</li> <li>Hybrid copper-fiber transceiver module</li> </ul>
Operating temperature	-10°C to +50°C (14°F to 122°F)
Storage temperature	-40°C to +70°C (-40°F to +158°F)
Operating humidity	5% RH to 95% RH, noncondensing
Storage humidity	5% RH to 95% RH, noncondensing
Operating altitude	-60 m to +5000 m (-196.85 ft to +16404.20 ft)
Console port	Used by technical personnel only for device configuration and management.
10GE/P++SFP	100M/1000M/2.5G/5G/10G hybrid copper-fiber port, which can also operate as a 10G copper port. When the AP operates in fit AP mode, the port is represented by interface number Ten-GigabitEthernet 1/0/1 in the MAP file and Ten-GigabitEthernet 1 for configuration on the AC.
10GE/PoE++	100M/1000M/2.5G/5G/10G copper Ethernet port, which can also operate as a 10G fiber port. The port is used for connecting the AP to an uplink device for Internet or MAN access. It can also act as a standard PoE port. When the AP operates in fit AP mode, the port is represented by interface number Ten-GigabitEthernet 1/0/1 in the MAP file and Ten-GigabitEthernet 1

Item	Description
	for configuration on the AC.
2.5GE/ PSE	100M/1000M copper Ethernet port, used for connecting a downlink device. The AP can supply power through this port to a standard PD with a maximum power consumption of 15 W. When the AP operates in fit AP mode, the port is represented by interface number Smartrate-Ethernet1/0/1 in the MAP file and Smartrate-Ethernet 1 for configuration on the AC.
USB port	Compliant with USB 2.0. Note: By default, the USB port is disabled. To enable the USB port, execute the <b>usb enable</b> command in AP view.
Power port (54 VDC)	Used for receiving power from a local power source.
Reset button	The function of the reset button varies by duration for which it is pressed. For more information, see " <a href="#">LED description for the reset button.</a> "
LEDs	Yellow/green/blue. For more information about the LED status in different AP operating modes, see " <a href="#">LED descriptions for single-LED APs.</a> "

# WA7330X

## AP view and dimensions

### AP view

Figure1-27 AP view



## AP dimensions

Figure1-28 AP dimensions

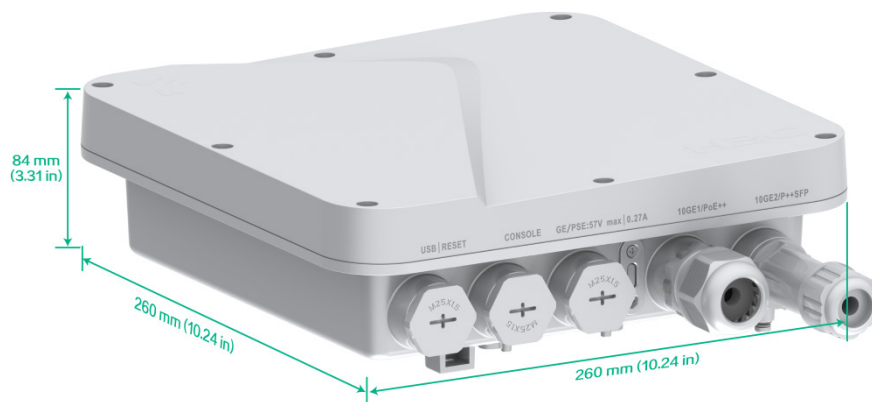

## Ports

The AP provides the following ports:

- One 10GE1/PoE++ port.
- One 10GE2/P++SFP port.
- One GE/PSE port.
- One console port.
- One USB port.

---

### NOTE:

The AP also provides a reset button.

---

Figure1-29 Ports (1)

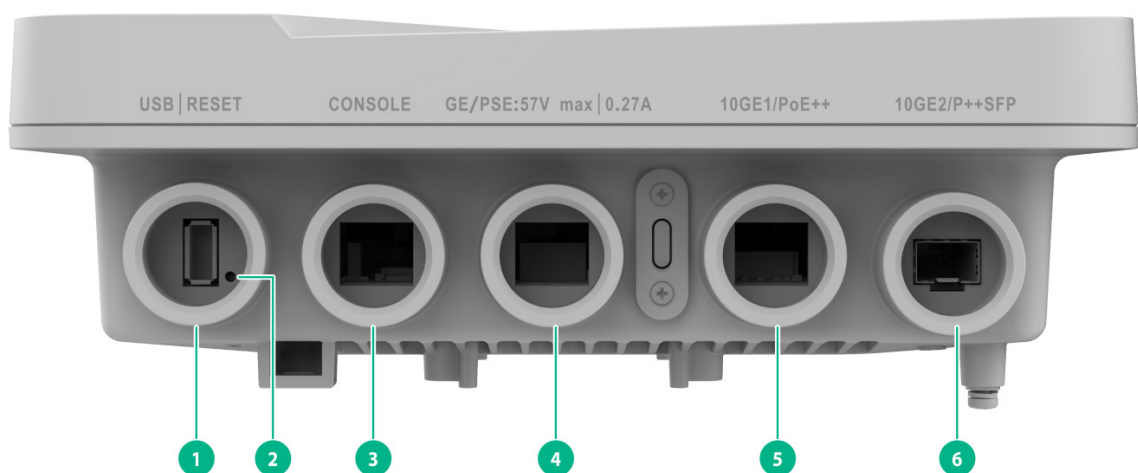

---

(1) USB port

(2) Reset button

(3) Console port

(4) GE/PSE port

(5) 10GE1/PoE port

(6) 10GE2/P++SFP port

---

# Technical specifications

**Table1-8 Technical specifications**

Item	Description
Dimensions (H x W x D)	84 x 260 x 260 mm (3.31 x 10.24 x 10.24 in)
Weight	2.03 kg (4.48 lb)
Power consumption	43 W
Antenna	<ul style="list-style-type: none"> <li>• 2.4G: 4 dBi gain</li> <li>• 5G: 4.3 dBi gain</li> <li>• 6G: 4.7 dBi gain</li> </ul>
Standard compliance	<ul style="list-style-type: none"> <li>• IEEE802.11a/b/g/n/ac/ax/be</li> <li>• IEEE802.3bt/at</li> </ul>
Powering option	IEEE802.3bt/at powering standard-compliant: <ul style="list-style-type: none"> <li>• Power adapter</li> <li>• PoE</li> <li>• Hybrid copper-fiber transceiver module</li> </ul>
Operating temperature	–40°C to +65°C (–40°F to +149°F)
Storage temperature	–40°C to +85°C (–40°F to +185°F)
Operating humidity	0% RH to 100% RH, noncondensing
Storage humidity	0% RH to 100% RH, noncondensing
Operating altitude	–60 m to +5000 m (–196.85 ft to +16404.20 ft)
IP rating	IP68
Console port	Used by technical personnel only for device configuration and management.
10GE1/PoE++	<p>100M/1000M/2.5G/5G/10G copper Ethernet port, used for connecting the AP to an uplink device for Internet or MAN access. It can also act as a standard PoE port.</p> <p>When the AP operates in fit AP mode, the port is represented by interface number 10GE1/0/1 in the MAP file and GigabitEthernet 1 for configuration on the AC.</p>
10GE2/P++SFP	<p>1000M/2.5G/5G/10G hybrid copper-fiber port.</p> <p>When the AP operates in fit AP mode, the port is represented by interface number XGE1/0/1 in the MAP file and Ten-GigabitEthernet 1 for configuration on the AC.</p>
GE/PSE	<p>10M/100M/1000M copper Ethernet port, used for connecting a downlink device. The AP can supply power through this port to a standard PD with a maximum power consumption of 15 W.</p> <p>When the AP operates in fit AP mode, the port is represented by interface number GE1/0/1 in the MAP file and GigabitEthernet 1 for configuration on the AC.</p>
USB port	<p>Compliant with USB 2.0.</p> <p>Note:</p> <p>By default, the USB port is disabled. To enable the USB port, execute the <b>usb enable</b> command in AP view.</p>
Reset button	The function of the reset button varies by duration for which it is pressed. For more information, see " <a href="#">LED description for the reset button.</a> "

Item	Description
LEDs	Yellow/green/blue. For more information about the LED status in different AP operating modes, see " <a href="#">LED descriptions for single-LED APs.</a> "

# WA7338-HI

## AP view and dimensions

### AP view

Figure1-30 AP view



### AP dimensions

Figure1-31 AP dimensions

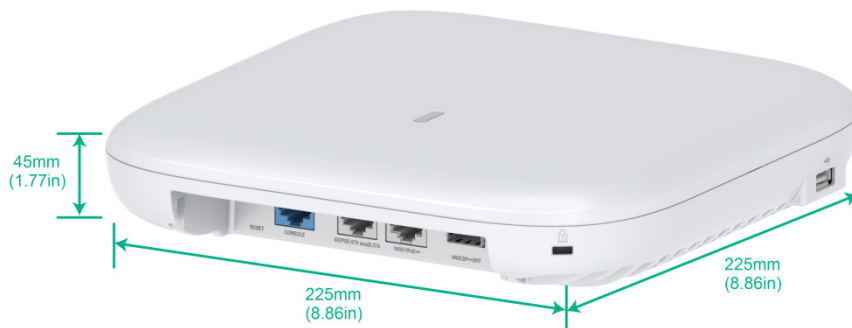

## Ports

The AP provides the following ports:

- One GE/PSE copper Ethernet port.
- One 10GE/PoE++ copper Ethernet port.
- One 10GE/P++SFP fiber port.
- One console port.
- One 54 VDC power port.

- One USB port.

**NOTE:**

The AP also provides a reset button and a security slot with a size of 7 × 3 mm (0.28 × 0.12 in).

**Figure1-32 Ports (1)**

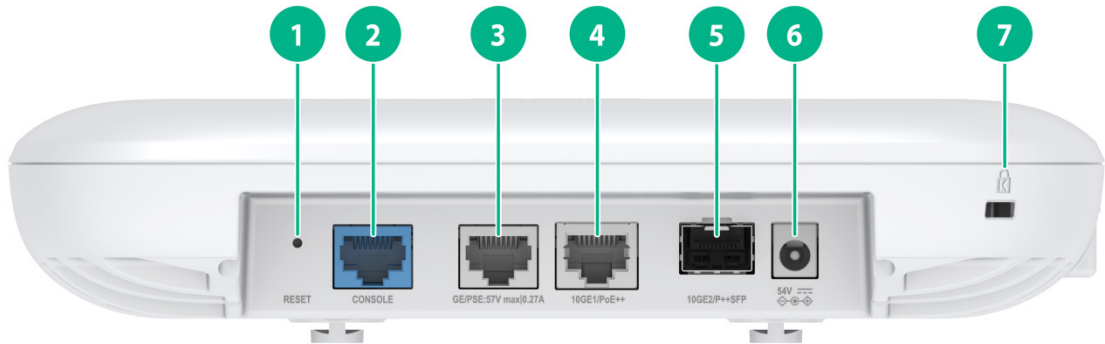

(1) Reset button	(2) Console port	(3) GE/PSE port
(4) 10GE1/PoE++ port	(5) 10GE2/P++SFP port	(6) 54 VDC power port
(7) Security slot		

**Figure1-33 Ports (2)**



(1) USB port
--------------

## Technical specifications

**Table1-9 Technical specifications**

Item	Description
Dimensions (H × W × D)	45 × 225 × 225 mm (1.77 × 8.86 × 8.86 in, excluding the mounting bracket)
Weight	1.43 kg (3.15 lb)
Power consumption	≤ 41.8 W
Antenna	Built-in antenna

Item	Description
Standard compliance	<ul style="list-style-type: none"> <li>IEEE802.11a/b/g/n/ac/ax/be</li> <li>IEEE802.3bt/at</li> </ul>
Powering option	<p>IEEE802.3bt/at powering standard-compliant:</p> <ul style="list-style-type: none"> <li>Power adapter</li> <li>PoE</li> <li>Hybrid copper-fiber transceiver module</li> </ul>
Operating temperature	–10°C to +50°C (14°F to 122°F)
Storage temperature	–40°C to +70°C (–40°F to +158°F)
Operating humidity	5% RH to 95% RH, noncondensing
Storage humidity	5% RH to 95% RH, noncondensing
Operating altitude	–60 m to +5000 m (–196.85 ft to +16404.20 ft)
Console port	Used by technical personnel only for device configuration and management.
10GE2/P++SFP	<p>1000M/2.5G/5G/10G hybrid copper-fiber port.</p> <p>When the AP operates in fit AP mode, the port is represented by interface number XGE1/0/2 in the MAP file and Ten-GigabitEthernet 2 for configuration on the AC.</p>
10GE1/PoE++	<p>100M/1000M/2.5G/5G/10G copper Ethernet port, used for connecting the AP to an uplink device for Internet or MAN access. It can also act as a standard PoE port.</p> <p>When the AP operates in fit AP mode, the port is represented by interface number 10GE1/0/1 in the MAP file and Ten-GigabitEthernet 1 for configuration on the AC.</p>
GE/PSE	<p>100M/1000M copper Ethernet port, used for connecting a downlink device. The AP can supply power through this port to a standard PD with a maximum power consumption of 15 W.</p> <p>When the AP operates in fit AP mode, the port is represented by interface number GE1/0/1 in the MAP file and GigabitEthernet 1 for configuration on the AC.</p>
USB port	<p>Compliant with USB 2.0.</p> <p>Note:</p> <p>By default, the USB port is disabled. To enable the USB port, execute the <b>usb enable</b> command in AP view.</p>
Power port (54 VDC)	Used for receiving power from a local power source.
Reset button	The function of the reset button varies by duration for which it is pressed. For more information, see " <a href="#">LED description for the reset button.</a> "
LEDs	Yellow/green/blue. For more information about the LED status in different AP operating modes, see " <a href="#">LED descriptions for single-LED APs.</a> "

# LEDs

**NOTE:**

The description for the status LED on the AP varies by AP operating mode. For information about the operating modes supported by the AP, see the release notes.

The LED status includes the color and flashing frequency of the LEDs, which indicates the AP operating status.

The AP has only one LED.

**Figure1-34 Single-LED AP (WA7338-HI as an example)**



## AP LEDs

**Table1-10 Single-LED APs**

AP series		Models	Description
Wi-Fi7	WA7300 AP series	WA7320, WA7320H-HI, WA7320i, WA7320XE, WA7322H-HI, WA7330i, WA7330X, WA7338-HI	For the LED descriptions, see " <a href="#">LED descriptions for single-LED APs.</a> "

## LED descriptions for single-LED APs

### LED descriptions before version changes

For the LED descriptions for the AP in versions earlier than 2615, see [Table1-11](#), [Table1-12](#), and [Table1-13](#).

**Table1-11 LED description (fit mode)**

LED color	LED status	Description
N/A	Off	No power is present or the LED has been turned off from the CLI.
Yellow	Steady on	The AP is initializing, or an initialization exception has occurred.
	Flashing (twice per second)	The Ethernet ports are down and no mesh links are established.

LED color	LED status	Description
Green	Steady on	The AP has started up and registered with an AC, but is in standby state (does not have any associated clients).
	Flashing (once every two seconds)	The AP has started up, but has not registered to any AC.
	Flashing (twice per second)	The AP is upgrading the image.
Blue	Flashing (once per second)	A radio has associated clients and the number of associated clients is less than the threshold.
Alternating between green and blue	Flashing (once per second)	The number of associated clients has exceeded the threshold.

**Table1-12 LED description (cloud mode)**

LED color	LED status	Description
N/A	Off	No power is present or the LED has been turned off from the CLI.
Yellow	Steady on	The AP is initializing, or an initialization exception has occurred.
	Flashing (twice per second)	The Ethernet ports are down and no mesh links are established.
Green	Steady on	The AP is in standby state, has connected to Cloudnet, but does not have any associated clients.
	Flashing (once per second)	The AP has connected to Cloudnet, and the radios have associated clients. The number of associated clients is less than the threshold.
	Flashing (twice per second)	The AP is upgrading the image.
Blue	Steady on	The AP is in standby state, has not connected to Cloudnet, and does not have any associated clients.
	Flashing (once per second)	The AP has not connected to Cloudnet, but the radios have associated clients. The number of associated clients is less than the threshold.
Alternating between green and blue	Flashing (once per second)	The number of associated clients has exceeded the threshold.

**Table1-13 LED description (anchor AC mode)**

LED color	LED status	Description
N/A	Off	No power is present or the LED has been turned off from the CLI.
Yellow	Steady on	The AP is initializing, or an initialization exception has occurred.
	Flashing (twice per second)	The Ethernet ports are down and no mesh links are established.
Green	Steady on	The AP has started up and is in standby state, but does not have any associated clients.
	Flashing (twice per second)	The AP is upgrading the image.
Blue	Flashing (once per second)	A radio has associated clients and the number of associated

LED color	LED status	Description
	second)	clients is less than the threshold.
Alternating between green and blue	Flashing (once per second)	The number of associated clients has exceeded the threshold.

## LED descriptions after version changes

For the LED descriptions for the AP in 2615 and later versions, see [Table1-14](#).

**Table1-14 LED description**

LED color	LED status	Description
N/A	Off	No power is present or the LED has been turned off from the CLI.
Yellow	Steady on	The AP is initializing, or an initialization exception has occurred.
	Flashing (twice per second)	The Ethernet ports are down and no mesh links are established.
Green	Steady on	The AP is in standby state and does not have any associated clients.
	Flashing (once every two seconds)	The AP has started up in fit mode, but has not registered to any AC.
	Flashing (once per second)	A radio has associated clients and the number of associated clients is less than the threshold.
	Flashing (twice per second)	The number of associated clients has exceeded the threshold.
Blue	Flashing (twice per second)	The AP is upgrading the image.

## LED description for the reset button

**Table1-15 LED description for the reset button**

Reset button	Press and hold duration (seconds)	LED color	LED status	Description
RESET	0 to 5	Green	Steady on	Reset the AP.
	5 to 20	Green	Flashing (twice per second)	Restore to the factory defaults.
	20 to 30	Yellow	Flashing (once every two seconds)	The AP is operating in fit mode.
			Flashing (twice per second)	The AP is operating in anchor AC mode.
			Flashing (four times per second)	The AP is operating in cloud mode.
	> 30	Yellow	Flashing (twice per second)	The AP is operating in anchor AC mode.
			Flashing (four times per second)	The AP is operating in cloud mode.

Reset button	Press and hold duration (seconds)	LED color	LED status	Description
		Green	Flashing (four times per second)	<p>The AP is switching from fit mode to cloud mode.</p> <p>Note: After you release the button, if the AP has switched from fit mode to cloud mode, it will restart for the new mode to take effect.</p>

# Transceiver modules

## Common transceiver modules

### Transceiver module, fiber connector, and optical fiber views

To connect a fiber port, use an SFP transceiver module and optical fibers with LC connectors.

**Figure1-35 SFP transceiver module**

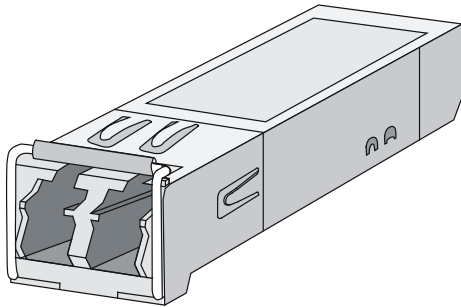

**Figure1-36 Optical fiber with LC connectors**

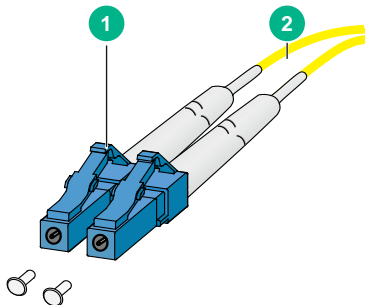

---

(1) LC connector

(2) Optical fiber

---

## Technical specifications

### WA7320, WA7320H-HI, WA7320i, WA7330i, and WA7338-HI

**Table1-16 SFP-XG-CPRI-IR-SM1310 transceiver module specifications**

Item	SFP-XG-CPRI-IR-SM1310
Central wavelength	1310 nm
Maximum transmission distance	1.4 km (0.87 miles)
Data rate	4920 to 10310 Mbps
Connector type	LC
Fiber mode	SMF

Item	SFP-XG-CPRI-IR-SM1310
Fiber diameter	9/125 $\mu\text{m}$
Tx optical power	-8.2 to +0.5 dBm

**Table1-17 SFP-2.5G-LX10-SM1310-DR-I transceiver module specifications**

Item	SFP-2.5G-LX10-SM1310-DR-I
Central wavelength	1310 nm
Maximum transmission distance	10 km (6.21 miles)
Data rate	1228.8 to 2457.6 Mbps
Connector type	LC
Fiber mode	SMF
Fiber diameter	9/125 $\mu\text{m}$
Tx optical power	-7 to +2 dBm

## WA7320XE and WA7330X

**Table1-18 SFP-GE-SX-MM850-A transceiver module specifications**

Item	SFP-GE-SX-MM850-A
Central wavelength	850 nm
Maximum transmission distance	550 m (1804.46 ft)
Data rate	1250 Mbps
Connector type	Duplex LC
Fiber mode	MMF
Fiber diameter	50 $\mu\text{m}$
Tx optical power	-9.5 to 0 dBm
Receiving sensitivity	$\leq -17$ dBm
Optical saturation	$\leq -3$ dBm

**Table1-19 SFP-GE-LX-SM1310-A transceiver module specifications**

Item	SFP-GE-LX-SM1310-A
Central wavelength	1310 nm
Maximum transmission distance	10 km (6.21 miles)
Data rate	1250 Mbps
Connector type	Duplex LC
Fiber mode	SMF
Fiber diameter	9 $\mu\text{m}$
Tx optical power	-9.5 to -3 dBm
Receiving sensitivity	$\leq -20$ dBm
Optical saturation	$\leq -3$ dBm

**Table1-20 SFP-GE-LH40-SM1310 transceiver module specifications**

Item	SFP-GE-LH40-SM1310
Central wavelength	1310 nm
Maximum transmission distance	40 km (24.86 miles)
Data rate	1250 Mbps
Connector type	Duplex LC
Fiber mode	SMF
Fiber diameter	9 $\mu$ m
Tx optical power	-2 to +5 dBm
Receiving sensitivity	$\leq -22$ dBm
Optical saturation	$\leq -3$ dBm

**Table1-21 SFP-GE-LH40-SM1550 transceiver module specifications**

Item	SFP-GE-LH40-SM1550
Central wavelength	1550nm
Maximum transmission distance	40 km (24.86 miles)
Data rate	1250 Mbps
Connector type	Duplex LC
Fiber mode	SMF
Fiber diameter	9 $\mu$ m
Tx optical power	-4 to +1 dBm
Receiving sensitivity	$\leq -21$ dBm
Optical saturation	$\leq -3$ dBm

## Hybrid copper-fiber transceiver modules

### Hybrid copper-fiber transceiver module and hybrid copper-fiber connector views

This section applies to the WA7320, WA7320i, WA7330i, WA7338-HI, WA7320XE, and WA7330X APs.

Hybrid copper-fiber transceiver modules support both optical and electrical transmission and PoE power supply. To connect a hybrid copper-fiber port, use a hybrid copper-fiber transceiver module and a hybrid copper-fiber cable with hybrid copper-fiber connectors.

**Figure1-37 Hybrid copper-fiber transceiver module**

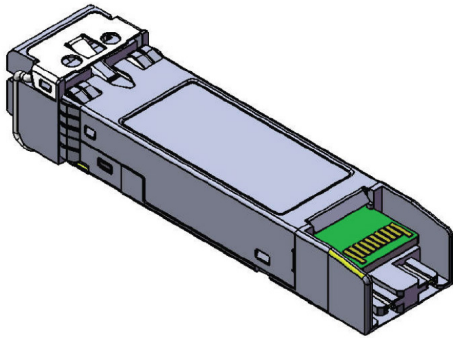

**Figure1-38 Hybrid copper-fiber cable with hybrid copper-fiber connectors**

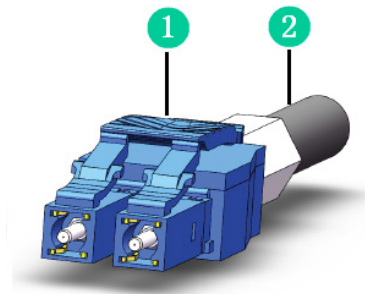

(1) Hybrid copper-fiber connector

(2) Hybrid copper-fiber cable

## Technical specifications

### GE hybrid copper-fiber transceiver module

**Table1-22 H3C-SFP-GE-POE GE hybrid copper-fiber transceiver module specifications**

Item	H3C-SFP-GE-POE
Operating wavelength	1310 nm
Maximum transmission distance	10 km (6.21 miles)
Data rate	1.25 Gbps
Connector type	LC
Maximum power consumption	1.0 W
Operating temperature range	-40°C to +85°C (-40°F to +185°F)
Tx optical power	-9 to -1 dBm

### 10GE hybrid copper-fiber transceiver module

**Table1-23 H3C-SFP-XG-POE-MR 10GE multi-rate hybrid copper-fiber transceiver module specifications**

Item	H3C-SFP-XG-POE-MR
Operating wavelength	1310 nm
Maximum transmission distance	1.4 km (0.87 miles)

<b>Item</b>	<b>H3C-SFP-XG-POE-MR</b>
Data rate	10.3125 Gbps
Connector type	LC
Maximum power consumption	1.2 W
Operating temperature range	-40°C to +85°C (-40°F to +185°F)
Tx optical power	-8.2 to +0.5 dBm

# Receive Sensitivity Values

Receive sensitivity is the minimum signal receive power at the antenna port required for correct wireless device operation. A lower receive sensitivity value indicates better receive performance of the wireless device.

## WA7320

Table1-24 Receive Sensitivity Values

Radio	6GHz Radio	5GHz Radio	2.4GHz Radio
	Rx sensitivity (dBm) NSS1	Rx sensitivity (dBm) NSS1	Rx sensitivity (dBm) NSS1
<b>802.11/11b</b>			
1 Mbps	-	-	-98
11 Mbps	-	-	-90
<b>802.11a/g</b>			
6 Mbps	-	-96	-95
24 Mbps	-	-87	-86
54 Mbps	-	-78	-77
<b>802.11n HT20</b>			
MCS0	-	-96	-95
MCS4	-	-87	-86
MCS7	-	-77	-76
<b>802.11n HT40</b>			
MCS0	-	-94	-94
MCS4	-	-85	-84
MCS7	-	-75	-74
<b>802.11ac VHT20</b>			
MCS0	-	-95	-
MCS4	-	-86	-
MCS7	-	-77	-
MCS8	-	-73	-
MCS9	-	-	-
<b>802.11ac VHT40</b>			
MCS0	-	-93	-
MCS4	-	-84	-
MCS7	-	-74	-

Radio	6GHz Radio	5GHz Radio	2.4GHz Radio
	Rx sensitivity (dBm) NSS1	Rx sensitivity (dBm) NSS1	Rx sensitivity (dBm) NSS1
MCS8	-	-72	-
MCS9	-	-69	-
<b>802.11ac VHT80</b>			
MCS0	-	-91	-
MCS4	-	-82	-
MCS7	-	-72	-
MCS8	-	-69	-
MCS9	-	-66	-
<b>802.11ac VHT160</b>			
MCS0	-	-88	-
MCS4	-	-78	-
MCS7	-	-68	-
MCS8	-	-66	-
MCS9	-	-63	-
<b>802.11ax HE20</b>			
MCS0	-96	-96	-96
MCS4	-87	-86	-86
MCS7	-77	-76	-77
MCS8	-74	-74	-74
MCS9	-70	-71	-72
MCS10	-68	-68	-69
MCS11	-65	-65	-65
<b>802.11ax HE40</b>			
MCS0	-93	-94	-93
MCS4	-83	-85	-84
MCS7	-74	-75	-74
MCS8	-72	-72	-71
MCS9	-69	-69	-68
MCS10	-67	-67	-66
MCS11	-63	-64	-63
<b>802.11ax HE80</b>			
MCS0	-90	-91	-
MCS4	-81	-81	-

Radio	6GHz Radio	5GHz Radio	2.4GHz Radio
	Rx sensitivity (dBm) NSS1	Rx sensitivity (dBm) NSS1	Rx sensitivity (dBm) NSS1
MCS7	-71	-70	-
MCS8	-67	-68	-
MCS9	-64	-65	-
MCS10	-62	-63	-
MCS11	-60	-61	-
<b>802.11ax HE160</b>			
MCS0	-87	-88	-
MCS4	-78	-78	-
MCS7	-68	-68	-
MCS8	-66	-65	-
MCS9	-63	-62	-
MCS10	-60	-60	-
MCS11	-57	-57	-
<b>802.11be EHT20</b>			
MCS0	-96	-97	-
MCS4	-87	-88	-
MCS7	-77	-79	-
MCS8	-75	-75	-
MCS9	-70	-71	-
MCS10	-67	-68	-
MCS11	-64	-65	-
MCS12	-62	-62	-
MCS13	-58	-58	-
<b>802.11be EHT40</b>			
MCS0	-94	-94	-
MCS4	-85	-86	-
MCS7	-75	-76	-
MCS8	-73	-73	-
MCS9	-69	-70	-
MCS10	-66	-66	-
MCS11	-63	-63	-
MCS12	-60	-61	-
MCS13	-57	-58	-

Radio	6GHz Radio	5GHz Radio	2.4GHz Radio
	Rx sensitivity (dBm) NSS1	Rx sensitivity (dBm) NSS1	Rx sensitivity (dBm) NSS1
<b>802.11be EHT80</b>			
MCS0	-90	-91	-
MCS4	-81	-83	-
MCS7	-71	-72	-
MCS8	-68	-70	-
MCS9	-66	-66	-
MCS10	-63	-63	-
MCS11	-60	-60	-
MCS12	-57	-57	-
MCS13	-54	-55	-
<b>802.11be EHT160</b>			
MCS0	-87	-88	-
MCS4	-78	-79	-
MCS7	-69	-69	-
MCS8	-66	-66	-
MCS9	-63	-63	-
MCS10	-60	-60	-
MCS11	-56	-57	-
MCS12	-53	-54	-
MCS13	-50	-51	-

## WA7320i

Table1-25 Receive Sensitivity Values

Radio	6GHz Radio	5GHz Radio	2.4GHz Radio
	Rx sensitivity (dBm) NSS1	Rx sensitivity (dBm) NSS1	Rx sensitivity (dBm) NSS1
<b>802.11/11b</b>			
1 Mbps	-	-	-99
11 Mbps	-	-	-93
<b>802.11a/g</b>			
6 Mbps	-	-93	-97

Radio	6GHz Radio	5GHz Radio	2.4GHz Radio
	Rx sensitivity (dBm) NSS1	Rx sensitivity (dBm) NSS1	Rx sensitivity (dBm) NSS1
24 Mbps	-	-84	-88
54 Mbps	-	-75	-79
<b>802.11n HT20</b>			
MCS0	-	-92	-95
MCS4	-	-82	-86
MCS7	-	-74	-78
<b>802.11n HT40</b>			
MCS0	-	-90	-94
MCS4	-	-80	-84
MCS7	-	-72	-76
<b>802.11ac VHT20</b>			
MCS0	-	-92	-
MCS4	-	-82	-
MCS7	-	-74	-
MCS8	-	-70	-
MCS9	-	-	-
<b>802.11ac VHT40</b>			
MCS0	-	-91	-
MCS4	-	-81	-
MCS7	-	-72	-
MCS8	-	-70	-
MCS9	-	-67	-
<b>802.11ac VHT80</b>			
MCS0	-	-88	-
MCS4	-	-78	-
MCS7	-	-69	-
MCS8	-	-66	-
MCS9	-	-63	-
<b>802.11ac VHT160</b>			
MCS0	-	-85	-
MCS4	-	-75	-
MCS7	-	-66	-
MCS8	-	-64	-

Radio	6GHz Radio	5GHz Radio	2.4GHz Radio
	Rx sensitivity (dBm) NSS1	Rx sensitivity (dBm) NSS1	Rx sensitivity (dBm) NSS1
MCS9	-	-61	-
<b>802.11ax HE20</b>			
MCS0	-92	-94	-96
MCS4	-82	-84	-87
MCS7	-73	-75	-79
MCS8	-71	-73	-76
MCS9	-68	-70	-73
MCS10	-66	-67	-71
MCS11	-63	-64	-68
<b>802.11ax HE40</b>			
MCS0	-91	-92	-95
MCS4	-81	-82	-85
MCS7	-72	-73	-76
MCS8	-70	-70	-74
MCS9	-67	-67	-71
MCS10	-64	-64	-68
MCS11	-60	-61	-65
<b>802.11ax HE80</b>			
MCS0	-88	-88	-
MCS4	-78	-78	-
MCS7	-70	-70	-
MCS8	-67	-67	-
MCS9	-64	-64	-
MCS10	-61	-61	-
MCS11	-58	-58	-
<b>802.11ax HE160</b>			
MCS0	-85	-85	-
MCS4	-75	-75	-
MCS7	-67	-67	-
MCS8	-64	-64	-
MCS9	-61	-61	-
MCS10	-59	-59	-
MCS11	-56	-56	-

Radio	6GHz Radio	5GHz Radio	2.4GHz Radio
	Rx sensitivity (dBm) NSS1	Rx sensitivity (dBm) NSS1	Rx sensitivity (dBm) NSS1
<b>802.11be EHT20</b>			
MCS0	-94	-95	-
MCS4	-84	-85	-
MCS7	-75	-76	-
MCS8	-72	-73	-
MCS9	-69	-70	-
MCS10	-66	-68	-
MCS11	-63	-65	-
MCS12	-61	-62	-
MCS13	-58	-58	-
<b>802.11be EHT40</b>			
MCS0	-93	-93	-
MCS4	-83	-83	-
MCS7	-74	-74	-
MCS8	-71	-71	-
MCS9	-68	-68	-
MCS10	-65	-65	-
MCS11	-62	-62	-
MCS12	-60	-60	-
MCS13	-57	-57	-
<b>802.11be EHT80</b>			
MCS0	-89	-89	-
MCS4	-79	-79	-
MCS7	-70	-70	-
MCS8	-68	-68	-
MCS9	-65	-65	-
MCS10	-63	-63	-
MCS11	-60	-60	-
MCS12	-57	-57	-
MCS13	-54	-54	-
<b>802.11be EHT160</b>			
MCS0	-86	-86	-
MCS4	-76	-76	-

Radio	6GHz Radio	5GHz Radio	2.4GHz Radio
	Rx sensitivity (dBm) NSS1	Rx sensitivity (dBm) NSS1	Rx sensitivity (dBm) NSS1
MCS7	-67	-67	-
MCS8	-65	-65	-
MCS9	-62	-62	-
MCS10	-60	-60	-
MCS11	-57	-57	-
MCS12	-54	-54	-
MCS13	-51	-51	-
<b>802.11be EHT320</b>			
MCS0	-84	-	-
MCS4	-74	-	-
MCS7	-65	-	-
MCS8	-63	-	-
MCS9	-60	-	-
MCS10	-58	-	-
MCS11	-55	-	-
MCS12	-52	-	-
MCS13	-49	-	-

## WA7320XE

Table1-26 Receive Sensitivity Values

Radio	6GHz Radio	5GHz Radio	2.4GHz Radio
	Rx sensitivity (dBm) NSS1	Rx sensitivity (dBm) NSS1	Rx sensitivity (dBm) NSS1
<b>802.11/11b</b>			
1 Mbps	-	-	-97
11 Mbps	-	-	-89
<b>802.11a/g</b>			
6 Mbps	-	-92	-95
24 Mbps	-	-83	-86
54 Mbps	-	-74	-76
<b>802.11n HT20</b>			

Radio	6GHz Radio	5GHz Radio	2.4GHz Radio
	Rx sensitivity (dBm) NSS1	Rx sensitivity (dBm) NSS1	Rx sensitivity (dBm) NSS1
MCS0	-	-91	-94
MCS4	-	-81	-83
MCS7	-	-72	-73
<b>802.11n HT40</b>			
MCS0	-	-89	-91
MCS4	-	-79	-81
MCS7	-	-70	-72
<b>802.11ac VHT20</b>			
MCS0	-	-91	-
MCS4	-	-81	-
MCS7	-	-73	-
MCS8	-	-69	-
MCS9	-	-	-
<b>802.11ac VHT40</b>			
MCS0	-	-87	-
MCS4	-	-78	-
MCS7	-	-70	-
MCS8	-	-68	-
MCS9	-	-65	-
<b>802.11ac VHT80</b>			
MCS0	-	-85	-
MCS4	-	-75	-
MCS7	-	-67	-
MCS8	-	-65	-
MCS9	-	-62	-
<b>802.11ac VHT160</b>			
MCS0	-	-83	-83
MCS4	-	-73	-73
MCS7	-	-65	-65
MCS8	-	-63	-63
MCS9	-	-60	-60
<b>802.11ax HE20</b>			
MCS0	-92	-92	-93

Radio	6GHz Radio	5GHz Radio	2.4GHz Radio
	Rx sensitivity (dBm) NSS1	Rx sensitivity (dBm) NSS1	Rx sensitivity (dBm) NSS1
MCS4	-82	-82	-83
MCS7	-73	-73	-75
MCS8	-71	-71	-73
MCS9	-69	-69	-70
MCS10	-66	-66	-67
MCS11	-62	-62	-64
<b>802.11ax HE40</b>			
MCS0	-90	-90	-91
MCS4	-79	-79	-81
MCS7	-70	-70	-73
MCS8	-69	-69	-71
MCS9	-67	-67	-68
MCS10	-64	-64	-65
MCS11	-60	-60	-62
<b>802.11ax HE80</b>			
MCS0	-88	-88	-
MCS4	-77	-77	-
MCS7	-68	-68	-
MCS8	-67	-67	-
MCS9	-65	-65	-
MCS10	-62	-62	-
MCS11	-58	-58	-
<b>802.11ax HE160</b>			
MCS0	-86	-86	-
MCS4	-75	-75	-
MCS7	-66	-66	-
MCS8	-65	-65	-
MCS9	-63	-63	-
MCS10	-60	-60	-
MCS11	-56	-56	-
<b>802.11be EHT20</b>			
MCS0	-91	-91	-
MCS4	-81	-81	-

Radio	6GHz Radio	5GHz Radio	2.4GHz Radio
	Rx sensitivity (dBm) NSS1	Rx sensitivity (dBm) NSS1	Rx sensitivity (dBm) NSS1
MCS7	-73	-73	-
MCS8	-71	-71	-
MCS9	-69	-69	-
MCS10	-67	-67	-
MCS11	-64	-64	-
MCS12	-61	-61	-
MCS13	-58	-58	-
<b>802.11be EHT40</b>			
MCS0	-89	-89	-
MCS4	-79	-79	-
MCS7	-71	-71	-
MCS8	-69	-69	-
MCS9	-67	-67	-
MCS10	-65	-65	-
MCS11	-62	-62	-
MCS12	-59	-59	-
MCS13	-56	-56	-
<b>802.11be EHT80</b>			
MCS0	-87	-87	-
MCS4	-77	-77	-
MCS7	-69	-69	-
MCS8	-67	-67	-
MCS9	-65	-65	-
MCS10	-63	-63	-
MCS11	-60	-60	-
MCS12	-57	-57	-
MCS13	-54	-54	-
<b>802.11be EHT160</b>			
MCS0	-85	-85	-
MCS4	-75	-75	-
MCS7	-66	-66	-
MCS8	-64	-64	-
MCS9	-61	-61	-
MCS10	-59	-59	-

Radio	6GHz Radio	5GHz Radio	2.4GHz Radio
	Rx sensitivity (dBm) NSS1	Rx sensitivity (dBm) NSS1	Rx sensitivity (dBm) NSS1
MCS11	-56	-56	-
MCS12	-53	-53	-
MCS13	-50	-50	-
<b>802.11be EHT320</b>			
MCS0	-83	-	-
MCS4	-72	-	-
MCS7	-63	-	-
MCS8	-61	-	-
MCS9	-59	-	-
MCS10	-57	-	-
MCS11	-54	-	-
MCS12	-51	-	-
MCS13	-48	-	-

## WA7320H-HI

Table1-27 Receive Sensitivity Values

Radio	6GHz Radio	5GHz Radio	2.4GHz Radio
	Rx sensitivity (dBm) NSS1	Rx sensitivity (dBm) NSS1	Rx sensitivity (dBm) NSS1
<b>802.11/11b</b>			
1 Mbps	-	-	-98
11 Mbps	-	-	-89
<b>802.11a/g</b>			
6 Mbps	-	-97	-95
24 Mbps	-	-89	-86
54 Mbps	-	-80	-76
<b>802.11n HT20</b>			
MCS0	-	-93	-93
MCS4	-	-83	-83
MCS7	-	-75	-75
<b>802.11n HT40</b>			

Radio	6GHz Radio	5GHz Radio	2.4GHz Radio
	Rx sensitivity (dBm) NSS1	Rx sensitivity (dBm) NSS1	Rx sensitivity (dBm) NSS1
MCS0	-	-90	-90
MCS4	-	-80	-80
MCS7	-	-72	-72
<b>802.11ac VHT20</b>			
MCS0	-	-93	-
MCS4	-	-83	-
MCS7	-	-75	-
MCS8	-	-70	-
MCS9	-	-	-
<b>802.11ac VHT40</b>			
MCS0	-	-90	-
MCS4	-	-80	-
MCS7	-	-72	-
MCS8	-	-69	-
MCS9	-	-66	-
<b>802.11ac VHT80</b>			
MCS0	-	-87	-
MCS4	-	-77	-
MCS7	-	-69	-
MCS8	-	-66	-
MCS9	-	-63	-
<b>802.11ac VHT160</b>			
MCS0	-	-84	-
MCS4	-	-74	-
MCS7	-	-66	-
MCS8	-	-63	-
MCS9	-	-60	-
<b>802.11ax HE20</b>			
MCS0	-93	-93	-93
MCS4	-83	-83	-83
MCS7	-75	-75	-75
MCS8	-72	-72	-72
MCS9	-69	-69	-68

Radio	6GHz Radio	5GHz Radio	2.4GHz Radio
	Rx sensitivity (dBm) NSS1	Rx sensitivity (dBm) NSS1	Rx sensitivity (dBm) NSS1
MCS10	-66	-66	-66
MCS11	-63	-63	-63
<b>802.11ax HE40</b>			
MCS0	-90	-90	-90
MCS4	-80	-80	-80
MCS7	-72	-72	-72
MCS8	-69	-69	-69
MCS9	-66	-66	-65
MCS10	-63	-63	-63
MCS11	-60	-60	-60
<b>802.11ax HE80</b>			
MCS0	-88	-87	-
MCS4	-77	-77	-
MCS7	-68	-69	-
MCS8	-67	-66	-
MCS9	-65	-63	-
MCS10	-62	-60	-
MCS11	-59	-57	-
<b>802.11ax HE160</b>			
MCS0	-84	-84	-
MCS4	-74	-74	-
MCS7	-66	-66	-
MCS8	-63	-63	-
MCS9	-60	-60	-
MCS10	-59	-57	-
MCS11	-57	-54	-
<b>802.11be EHT20</b>			
MCS0	-93	-93	-
MCS4	-83	-83	-
MCS7	-75	-75	-
MCS8	-72	-72	-
MCS9	-69	-69	-
MCS10	-66	-66	-

Radio	6GHz Radio	5GHz Radio	2.4GHz Radio
	Rx sensitivity (dBm) NSS1	Rx sensitivity (dBm) NSS1	Rx sensitivity (dBm) NSS1
MCS11	-63	-63	-
MCS12	-60	-60	-
MCS13	-57	-57	-
<b>802.11be EHT40</b>			
MCS0	-90	-90	-
MCS4	-80	-80	-
MCS7	-71	-72	-
MCS8	-69	-69	-
MCS9	-66	-66	-
MCS10	-63	-63	-
MCS11	-60	-60	-
MCS12	-57	-57	-
MCS13	-54	-54	-
<b>802.11be EHT80</b>			
MCS0	-87	-87	-
MCS4	-77	-77	-
MCS7	-69	-69	-
MCS8	-66	-66	-
MCS9	-63	-63	-
MCS10	-61	-60	-
MCS11	-59	-57	-
MCS12	-56	-54	-
MCS13	-53	-51	-
<b>802.11be EHT160</b>			
MCS0	-85	-84	-
MCS4	-75	-74	-
MCS7	-66	-66	-
MCS8	-64	-63	-
MCS9	-61	-60	-
MCS10	-59	-57	-
MCS11	-57	-54	-
MCS12	-54	-51	-
MCS13	-51	-48	-

Radio	6GHz Radio	5GHz Radio	2.4GHz Radio
	Rx sensitivity (dBm) NSS1	Rx sensitivity (dBm) NSS1	Rx sensitivity (dBm) NSS1
<b>802.11be EHT320</b>			
MCS0	-	-	-
MCS4	-	-	-
MCS7	-	-	-
MCS8	-	-	-
MCS9	-	-	-
MCS10	-	-	-
MCS11	-	-	-
MCS12	-	-	-
MCS13	-	-	-

## WA7330i

Table1-28 Receive Sensitivity Values

Radio	6GHz Radio	5GHz Radio	2.4GHz Radio
	Rx sensitivity (dBm) NSS1	Rx sensitivity (dBm) NSS1	Rx sensitivity (dBm) NSS1
<b>802.11/11b</b>			
1 Mbps	-	-	-99
11 Mbps	-	-	-91
<b>802.11a/g</b>			
6 Mbps	-94	-94	-97
24 Mbps	-85	-85	-87
54 Mbps	-76	-76	-78
<b>802.11n HT20</b>			
MCS0	-	-93	-96
MCS4	-	-83	-86
MCS7	-	-76	-77
<b>802.11n HT40</b>			
MCS0	-	-92	-93
MCS4	-	-81	-83
MCS7	-	-73	-75

Radio	6GHz Radio	5GHz Radio	2.4GHz Radio
	Rx sensitivity (dBm) NSS1	Rx sensitivity (dBm) NSS1	Rx sensitivity (dBm) NSS1
<b>802.11ac VHT20</b>			
MCS0	-	-93	-
MCS4	-	-83	-
MCS7	-	-75	-
MCS8	-	-71	-
MCS9	-	-	-
<b>802.11ac VHT40</b>			
MCS0	-	-92	-
MCS4	-	-82	-
MCS7	-	-73	-
MCS8	-	-70	-
MCS9	-	-67	-
<b>802.11ac VHT80</b>			
MCS0	-	-89	-
MCS4	-	-79	-
MCS7	-	-70	-
MCS8	-	-67	-
MCS9	-	-64	-
<b>802.11ac VHT160</b>			
MCS0	-	-87	-
MCS4	-	-76	-
MCS7	-	-67	-
MCS8	-	-64	-
MCS9	-	-62	-
<b>802.11ax HE20</b>			
MCS0	-95	-95	-97
MCS4	-85	-85	-87
MCS7	-76	-76	-78
MCS8	-73	-73	-76
MCS9	-70	-71	-72
MCS10	-67	-67	-70
MCS11	-64	-64	-66
<b>802.11ax HE40</b>			

Radio	6GHz Radio	5GHz Radio	2.4GHz Radio
	Rx sensitivity (dBm) NSS1	Rx sensitivity (dBm) NSS1	Rx sensitivity (dBm) NSS1
MCS0	-92	-93	-95
MCS4	-82	-82	-85
MCS7	-73	-74	-76
MCS8	-70	-70	-73
MCS9	-68	-68	-70
MCS10	-65	-65	-68
MCS11	-62	-62	-65
<b>802.11ax HE80</b>			
MCS0	-89	-89	-
MCS4	-78	-78	-
MCS7	-70	-71	-
MCS8	-67	-67	-
MCS9	-64	-65	-
MCS10	-61	-61	-
MCS11	-58	-59	-
<b>802.11ax HE160</b>			
MCS0	-86	-86	-
MCS4	-75	-75	-
MCS7	-67	-67	-
MCS8	-64	-64	-
MCS9	-61	-62	-
MCS10	-59	-59	-
MCS11	-56	-57	-
<b>802.11be EHT20</b>			
MCS0	-95	-96	-
MCS4	-85	-85	-
MCS7	-76	-77	-
MCS8	-72	-74	-
MCS9	-69	-71	-
MCS10	-67	-68	-
MCS11	-64	-65	-
MCS12	-61	-62	-
MCS13	-58	-58	-

Radio	6GHz Radio	5GHz Radio	2.4GHz Radio
	Rx sensitivity (dBm) NSS1	Rx sensitivity (dBm) NSS1	Rx sensitivity (dBm) NSS1
<b>802.11be EHT40</b>			
MCS0	-93	-93	-
MCS4	-83	-83	-
MCS7	-73	-74	-
MCS8	-71	-72	-
MCS9	-68	-68	-
MCS10	-65	-65	-
MCS11	-61	-63	-
MCS12	-60	-60	-
MCS13	-55	-57	-
<b>802.11be EHT80</b>			
MCS0	-90	-89	-
MCS4	-80	-79	-
MCS7	-71	-70	-
MCS8	-69	-68	-
MCS9	-66	-65	-
MCS10	-63	-63	-
MCS11	-60	-59	-
MCS12	-56	-57	-
MCS13	-53	-54	-
<b>802.11be EHT160</b>			
MCS0	-87	-86	-
MCS4	-76	-76	-
MCS7	-67	-67	-
MCS8	-65	-65	-
MCS9	-62	-62	-
MCS10	-60	-60	-
MCS11	-57	-57	-
MCS12	-54	-54	-
MCS13	-51	-51	-
<b>802.11be EHT320</b>			
MCS0	-84	-	-
MCS4	-74	-	-

Radio	6GHz Radio	5GHz Radio	2.4GHz Radio
	Rx sensitivity (dBm) NSS1	Rx sensitivity (dBm) NSS1	Rx sensitivity (dBm) NSS1
MCS7	-65	-	-
MCS8	-63	-	-
MCS9	-60	-	-
MCS10	-58	-	-
MCS11	-54	-	-
MCS12	-52	-	-
MCS13	-48	-	-

## WA7330X

Table1-29 Receive Sensitivity Values

Radio	6GHz Radio	5GHz Radio	2.4GHz Radio
	Rx sensitivity (dBm) NSS1	Rx sensitivity (dBm) NSS1	Rx sensitivity (dBm) NSS1
<b>802.11/11b</b>			
1 Mbps	-	-	-99
11 Mbps	-	-	-91
<b>802.11a/g</b>			
6 Mbps	-	-95	-97
24 Mbps	-	-86	-88
54 Mbps	-	-77	-79
<b>802.11n HT20</b>			
MCS0	-	-94	-97
MCS4	-	-84	-86
MCS7	-	-75	-77
<b>802.11n HT40</b>			
MCS0	-	-90	-94
MCS4	-	-81	-84
MCS7	-	-74	-75
<b>802.11ac VHT20</b>			
MCS0	-	-93	-
MCS4	-	-84	-

Radio	6GHz Radio	5GHz Radio	2.4GHz Radio
	Rx sensitivity (dBm) NSS1	Rx sensitivity (dBm) NSS1	Rx sensitivity (dBm) NSS1
MCS7	-	-76	-
MCS8	-	-72	-
MCS9	-	-	-
<b>802.11ac VHT40</b>			
MCS0	-	-90	-
MCS4	-	-81	-
MCS7	-	-73	-
MCS8	-	-71	-
MCS9	-	-68	-
<b>802.11ac VHT80</b>			
MCS0	-	-89	-
MCS4	-	-78	-
MCS7	-	-69	-
MCS8	-	-67	-
MCS9	-	-65	-
<b>802.11ac VHT160</b>			
MCS0	-	-86	-
MCS4	-	-76	-
MCS7	-	-68	-
MCS8	-	-66	-
MCS9	-	-63	-
<b>802.11ax HE20</b>			
MCS0	-94	-95	-96
MCS4	-84	-85	-86
MCS7	-75	-76	-78
MCS8	-73	-74	-76
MCS9	-71	-72	-73
MCS10	-68	-69	-70
MCS11	-64	-65	-67
<b>802.11ax HE40</b>			
MCS0	-92	-93	-95
MCS4	-82	-83	-84
MCS7	-73	-74	-75

<b>Radio</b>	<b>6GHz Radio</b>	<b>5GHz Radio</b>	<b>2.4GHz Radio</b>
	Rx sensitivity (dBm) NSS1	Rx sensitivity (dBm) NSS1	Rx sensitivity (dBm) NSS1
MCS8	-71	-72	-73
MCS9	-69	-70	-71
MCS10	-66	-67	-68
MCS11	-63	-64	-65
<b>802.11ax HE80</b>			
MCS0	-88	-89	-
MCS4	-79	-80	-
MCS7	-71	-72	-
MCS8	-69	-70	-
MCS9	-66	-67	-
MCS10	-64	-65	-
MCS11	-62	-62	-
<b>802.11ax HE160</b>			
MCS0	-85	-87	-
MCS4	-76	-78	-
MCS7	-69	-70	-
MCS8	-67	-68	-
MCS9	-64	-65	-
MCS10	-61	-62	-
MCS11	-58	-58	-
<b>802.11be EHT20</b>			
MCS0	-92	-93	-
MCS4	-82	-83	-
MCS7	-74	-75	-
MCS8	-72	-73	-
MCS9	-70	-71	-
MCS10	-68	-69	-
MCS11	-65	-66	-
MCS12	-62	-63	-
MCS13	-59	-60	-
<b>802.11be EHT40</b>			
MCS0	-91	-91	-
MCS4	-81	-81	-

Radio	6GHz Radio	5GHz Radio	2.4GHz Radio
	Rx sensitivity (dBm) NSS1	Rx sensitivity (dBm) NSS1	Rx sensitivity (dBm) NSS1
MCS7	-73	-73	-
MCS8	-71	-71	-
MCS9	-69	-69	-
MCS10	-67	-67	-
MCS11	-64	-64	-
MCS12	-61	-61	-
MCS13	-58	-58	-
<b>802.11be EHT80</b>			
MCS0	-88	-89	-
MCS4	-78	-79	-
MCS7	-70	-71	-
MCS8	-68	-69	-
MCS9	-66	-67	-
MCS10	-64	-65	-
MCS11	-62	-62	-
MCS12	-59	-59	-
MCS13	-56	-56	-
<b>802.11be EHT160</b>			
MCS0	-86	-87	-
MCS4	-76	-77	-
MCS7	-67	-68	-
MCS8	-65	-66	-
MCS9	-62	-63	-
MCS10	-60	-61	-
MCS11	-58	-58	-
MCS12	-55	-55	-
MCS13	-52	-52	-
<b>802.11be EHT320</b>			
MCS0	-84	-	-
MCS4	-74	-	-
MCS7	-65	-	-
MCS8	-63	-	-
MCS9	-60	-	-
MCS10	-58	-	-

Radio	6GHz Radio	5GHz Radio	2.4GHz Radio
	Rx sensitivity (dBm) NSS1	Rx sensitivity (dBm) NSS1	Rx sensitivity (dBm) NSS1
MCS11	-55	-	-
MCS12	-52	-	-
MCS13	-49	-	-

## WA7338-HI

Table1-30 Receive Sensitivity Values

Radio	6GHz Radio	5GHz Radio	2.4GHz Radio
	Rx sensitivity (dBm) NSS1	Rx sensitivity (dBm) NSS1	Rx sensitivity (dBm) NSS1
<b>802.11/11b</b>			
1 Mbps	-	-	-99
11 Mbps	-	-	-92
<b>802.11a/g</b>			
6 Mbps	-	-95	-97
24 Mbps	-	-86	-89
54 Mbps	-	-77	-80
<b>802.11n HT20</b>			
MCS0	-	-95	-97
MCS4	-	-86	-88
MCS7	-	-76	-78
<b>802.11n HT40</b>			
MCS0	-	-92	-95
MCS4	-	-83	-85
MCS7	-	-73	-75
<b>802.11ac VHT20</b>			
MCS0	-	-94	-
MCS4	-	-85	-
MCS7	-	-76	-
MCS8	-	-72	-
MCS9	-	-	-
<b>802.11ac VHT40</b>			

Radio	6GHz Radio	5GHz Radio	2.4GHz Radio
	Rx sensitivity (dBm) NSS1	Rx sensitivity (dBm) NSS1	Rx sensitivity (dBm) NSS1
MCS0	-	-92	-
MCS4	-	-83	-
MCS7	-	-73	-
MCS8	-	-71	-
MCS9	-	-68	-
<b>802.11ac VHT80</b>			
MCS0	-	-89	-
MCS4	-	-80	-
MCS7	-	-70	-
MCS8	-	-67	-
MCS9	-	-64	-
<b>802.11ac VHT160</b>			
MCS0	-	-86	-
MCS4	-	-76	-
MCS7	-	-66	-
MCS8	-	-64	-
MCS9	-	-61	-
<b>802.11ax HE20</b>			
MCS0	-96	-95	-97
MCS4	-87	-85	-87
MCS7	-77	-75	-78
MCS8	-74	-73	-75
MCS9	-70	-70	-73
MCS10	-68	-67	-70
MCS11	-65	-64	-67
<b>802.11ax HE40</b>			
MCS0	-94	-92	-95
MCS4	-84	-83	-86
MCS7	-74	-73	-76
MCS8	-72	-70	-73
MCS9	-69	-67	-70
MCS10	-67	-65	-68
MCS11	-63	-62	-65

Radio	6GHz Radio	5GHz Radio	2.4GHz Radio
	Rx sensitivity (dBm) NSS1	Rx sensitivity (dBm) NSS1	Rx sensitivity (dBm) NSS1
<b>802.11ax HE80</b>			
MCS0	-90	-89	-
MCS4	-81	-80	-
MCS7	-71	-69	-
MCS8	-68	-67	-
MCS9	-65	-64	-
MCS10	-63	-62	-
MCS11	-61	-60	-
<b>802.11ax HE160</b>			
MCS0	-87	-86	-
MCS4	-78	-76	-
MCS7	-68	-66	-
MCS8	-66	-64	-
MCS9	-63	-61	-
MCS10	-60	-59	-
MCS11	-57	-56	-
<b>802.11be EHT20</b>			
MCS0	-96	-94	-
MCS4	-87	-85	-
MCS7	-77	-76	-
MCS8	-75	-73	-
MCS9	-71	-69	-
MCS10	-68	-66	-
MCS11	-65	-63	-
MCS12	-63	-60	-
MCS13	-59	-56	-
<b>802.11be EHT40</b>			
MCS0	-94	-92	-
MCS4	-85	-83	-
MCS7	-75	-73	-
MCS8	-73	-70	-
MCS9	-69	-67	-
MCS10	-66	-64	-

Radio	6GHz Radio	5GHz Radio	2.4GHz Radio
	Rx sensitivity (dBm) NSS1	Rx sensitivity (dBm) NSS1	Rx sensitivity (dBm) NSS1
MCS11	-63	-61	-
MCS12	-60	-59	-
MCS13	-57	-55	-
<b>802.11be EHT80</b>			
MCS0	-91	-89	-
MCS4	-82	-81	-
MCS7	-72	-70	-
MCS8	-69	-68	-
MCS9	-66	-64	-
MCS10	-63	-61	-
MCS11	-60	-58	-
MCS12	-57	-55	-
MCS13	-54	-52	-
<b>802.11be EHT160</b>			
MCS0	-87	-86	-
MCS4	-78	-77	-
MCS7	-69	-67	-
MCS8	-66	-64	-
MCS9	-63	-61	-
MCS10	-60	-58	-
MCS11	-57	-55	-
MCS12	-54	-52	-
MCS13	-51	-49	-
<b>802.11be EHT320</b>			
MCS0	-84	-	-
MCS4	-75	-	-
MCS7	-65	-	-
MCS8	-63	-	-
MCS9	-59	-	-
MCS10	-57	-	-
MCS11	-54	-	-
MCS12	-51	-	-
MCS13	-48	-	-

