



Cisco Catalyst 9600 Series Switches Hardware Installation Guide

First Published: 2019-04-15

Americas Headquarters

Cisco Systems, Inc.
170 West Tasman Drive
San Jose, CA 95134-1706
USA
<http://www.cisco.com>
Tel: 408 526-4000
800 553-NETS (6387)
Fax: 408 527-0883



CONTENTS

CHAPTER 1

Product Overview 1

- Chassis Overview 1
- Fan Tray Assembly 3
 - High Availability 5
 - Thresholds, Alarms, and Abnormal Acoustic Conditions 6
- Power Supply Module Overview 6
 - AC Power Supply Module 7
 - DC Power Supply Module 8
 - Power Supply Modes 9

CHAPTER 2

Preparing for Installation 11

- Safety Warnings 11
- Site Requirements 14
 - Temperature 14
 - Air Flow 15
 - Humidity 17
 - Altitude 17
 - Dust and Particles 17
 - Corrosion 18
 - EMI and Radio Frequency Interference 18
 - Shock and Vibration 19
 - Power Source Interruptions 19
 - System Grounding 20
 - Maintaining Safety with Electricity 22
 - Preventing ESD Damage 23

Power Requirements	23
Cabling Requirements	23
Rack-Mounting Guidelines	24
Site Preparation Checklist	25

CHAPTER 3**Installing the Switch 29**

Unpacking the Switch	29
Install the Switch as Shipped	30
Installing the Cable Guide on the Chassis with L-Brackets Preinstalled on the Chassis	30
Rack-Mounting the Chassis as Shipped	32
Install the Switch with Shelf Brackets	36
Installing the Shelf Kit L-Brackets	36
Installing the Shelf Brackets and the Crossbar	40
Installing the Cable Guide on the Chassis with Shelf Kit L-Bracket	42
Rack-Mounting the Chassis	43
Install the Switch in NEBS-Compliant Mode	50
NEBS-Compliant Air Filter	50
Rack-Mounting the Chassis in NEBS-Compliant Mode	50
Establishing System Ground	57
Attaching an ESD Strap	60
Verifying the Switch Chassis Installation	61

CHAPTER 4**Installing the Fan Tray 63**

Guidelines for Removing and Installing a Fan Tray	63
Removing a Fan Tray	63
Information About Replacing a Fan Tray	64
Enabling the Service Mode Before Removing the Fan Tray	64
Removing the Fan Tray from the Front of the Chassis	65
Removing the Fan Tray from the Rear of the Chassis	67
Installing a Fan Tray	70
Installing the Fan Tray from the Front Panel of the Chassis	71
Installing the Fan Tray from the Rear of the Chassis	72
Verifying Fan Tray Installation	73

CHAPTER 5	Installing a Power Supply Unit	75
	Required Tools and Equipment	75
	Removing and Installing Power Supply Modules	75
	Removing a Power Supply Module	77
	Installing a Power Supply Module	79
	Connecting to a Power Source	82
	Connecting to an AC Power Source	82
	Connecting to a DC Power Source	83
	Verifying the Power Supply Installation	86
	Removing and Installing Power Supply Blanks	86
	Finding the Serial Number	90

APPENDIX A	Technical Specifications	91
	C9606R Switch Chassis Specifications	91
	Power Supply Specifications	93
	2000W AC-Input Power Supply Specifications	93
	2000WAC Power Supply AC Power Cords	94
	2000W DC-Input Power Supply Specifications	97
	Chassis and Module Power and Heat Values	98
	Weight Specifications	99

APPENDIX B	LEDs	101
	Fan Tray LEDs	101
	Power Supply Modules LEDs	101
	Supervisor Module LEDs	102
	Line Card LEDs	103

APPENDIX C	Accessory Kit and Shelf Kit Contents	105
	Standard Accessory Kit Contents	105
	Shelf Kit Contents	106
	23-Inch Rack Mount Kit Contents	106



CHAPTER 1

Product Overview

- [Chassis Overview, on page 1](#)
- [Fan Tray Assembly, on page 3](#)
- [Power Supply Module Overview, on page 6](#)

Chassis Overview

The Cisco Catalyst 9606R Switch is a six-slot chassis, with two redundant supervisor module slots, four module slots, four power supply modules and a fan tray.

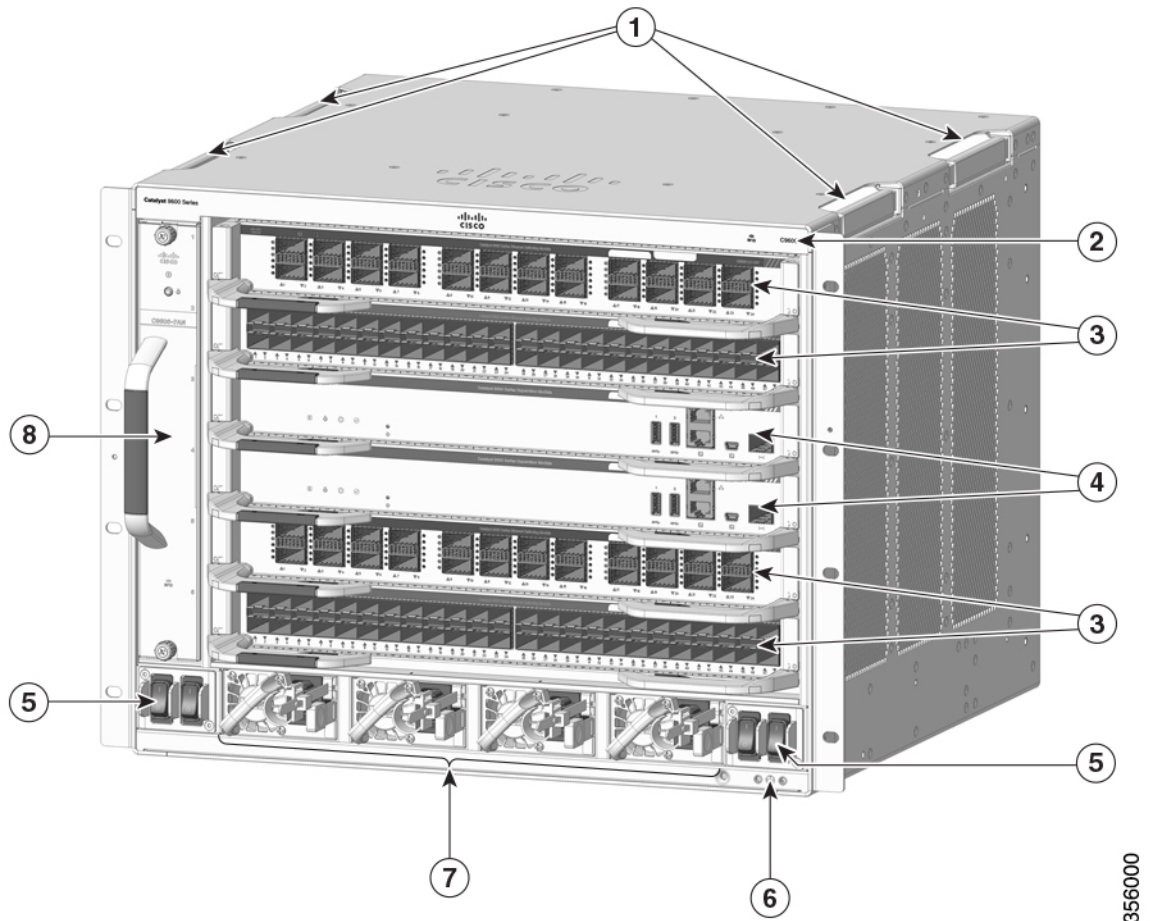
Table 1: Cisco Catalyst 9600R Switch Features

Feature	Description
Product ID	Cisco Catalyst 9606R
Chassis	Has six horizontal slots. Slots are numbered 1 to 6 from top to bottom.
Supervisor modules	Supports two supervisor modules. The following is the supported model — Cisco Catalyst 9600 Series Supervisor 1 Module (C9600-SUP-1). For more information about installing a supervisor module, see the Cisco Catalyst 9600 Series Switch Supervisor Module Installation Note.
Line Cards	Supports upto four line cards. The following are the supported line cards: <ul style="list-style-type: none">• Cisco Catalyst 9600 Series 48-Port 25GE/10GE/1GE¹ (C9600-LC-48YL — 48 ports that support SFP56 (48x1G/10G/25G ports)• Cisco Catalyst 9600 Series 24-Port 40GE/12-Port 100GE (C9600-LC-24C) — 24 ports that support QSFP28 (24x40G or 12x100G) For more information about installing a line card, see the Cisco Catalyst 9600 Series Switch Line Card Installation Note.
Fan tray assembly	Provides a single front and rear serviceable and hot-swappable fan tray with 9 fans.

Feature	Description
Power supplies	Has 4 power supply slots that supports upto 4 AC/DC power supply modules.
Backplane	Provides 6.4Tbps bandwidth per slot.

¹ 1G is currently not supported.

Figure 1: Front view of a Cisco Catalyst 9606R

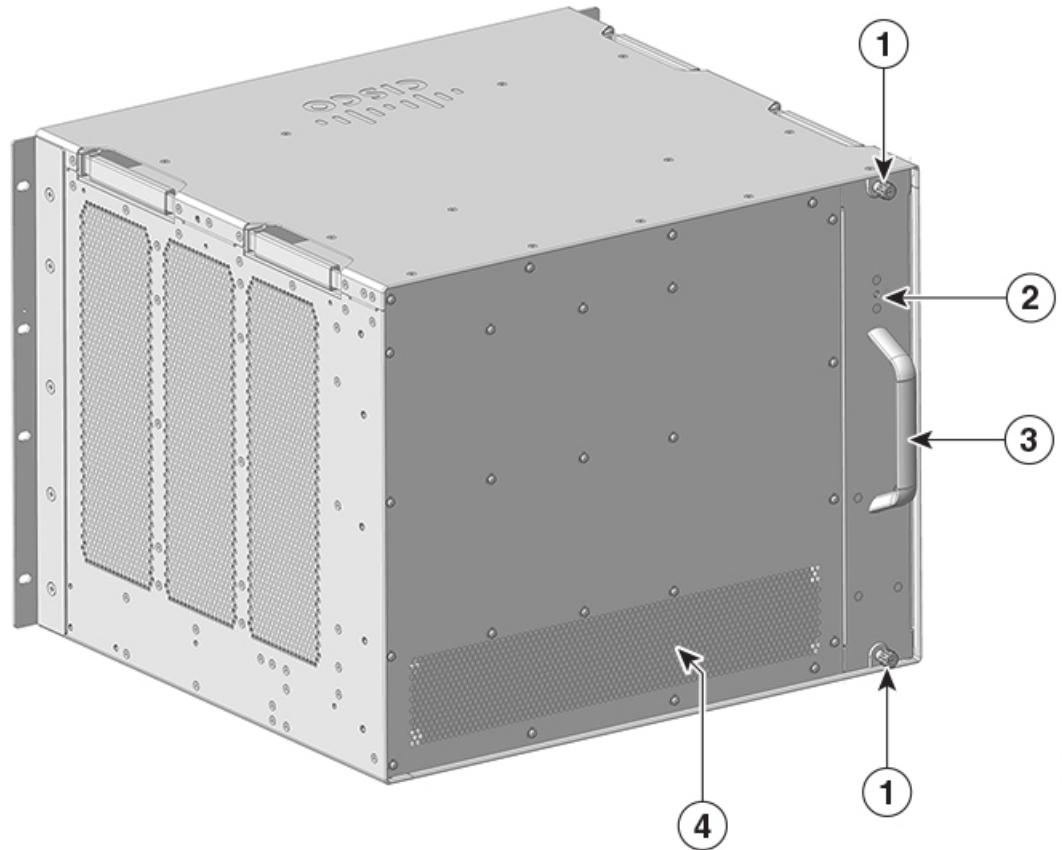


1	Chassis handholds	5	Power switches
2	Chassis Radio Frequency ID (RFID)	6	System ground with ground lug screw holes on each side
3	Line card slots	7	Power Supply modules
4	Supervisor Module slots	8	Fan tray assembly

Rear View of a Cisco Catalyst 9606R

The figure shows a rear view of the chassis, with the major components identified:

Figure 2: Rear View of a Cisco Catalyst 9606R



356015

1	Captive installation screws to remove the fan tray assembly.	3	Fan tray assembly handle
2	Blue beacon LED on the rear panel of the fan tray (always matches the blue beacon on the front panel of the fan tray)	4	Rear exhaust for the power supply modules

Fan Tray Assembly

The fan tray assembly (C9606-FAN) in Cisco Catalyst 9600 Series Switches consists of a fan tray and a connector that is attached to the fan tray. It is responsible for cooling the entire chassis and interfacing with environmental monitors to trigger alarms when conditions exceed thresholds. The fan tray provides cooling

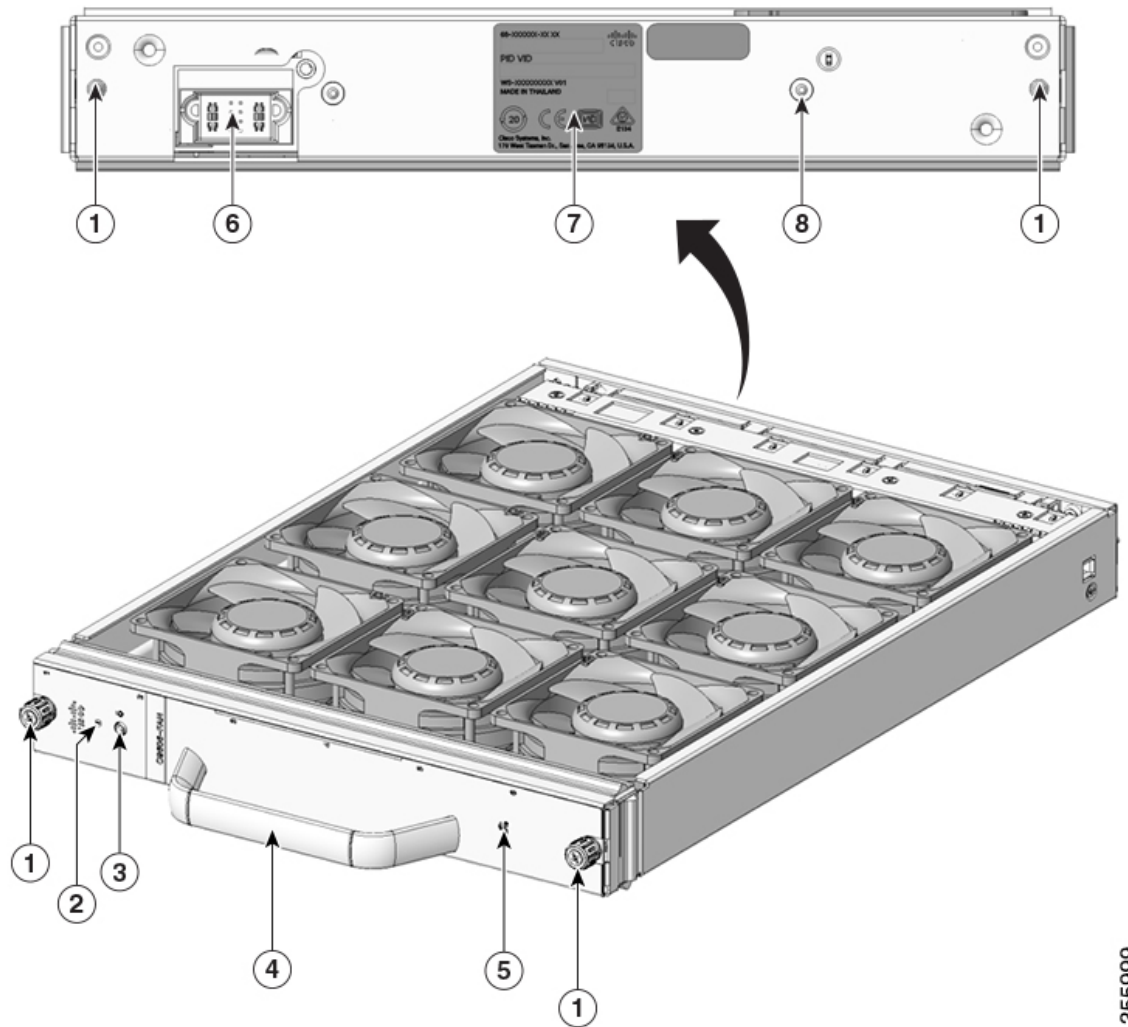
that is critical for the switch operation which could otherwise result in a switch being non-operational or causing permanent damage to the modules or components.

The following lists the features and functionalities of a Cisco Catalyst 9600 fan tray:

- Has nine individual fans (three rows of three each) and supports a minimum airflow of 720 cubic feet per minute (cfm) at 100 percent fan throttle.
- Has side-to-side airflow for balanced airflow across the inserted cards. When facing the front of the chassis, airflow direction is right to left.
- You can install and remove from the front and the rear.
- Has a built-in, front-facing, passive RFID tag that uses Ultra High Frequency (UHF) RFID technology and requires an RFID reader with compatible software.
- Provides N+1 redundancy with individual fans. Fan tray does not support redundancy; however with N+1 redundancy using individual fans, system ensures that there is no impact to the system performance even if one of the fans fails.
- Optimizes the fan-speed for temperature and pressure and maintains the minimum fan speeds and temperatures that the chassis requires, in ambient conditions.

The following figure shows C9606-FAN with the major components identified.

Figure 3: Fan Tray Assembly



355999

1	Captive installation screws on the front and the rear of the fan tray.	5	Fan tray RFID
2	Fan status LED	6	Fan tray connector
3	Switch to turn on the Blue Beacon LED.	7	Fan tray serial number
4	Front fan tray handle.	8	Blue beacon LED on the rear of the fan tray

High Availability

To ensure high availability, the system is designed to respond to fan failures by either minimising impact or by compensating and operating at a worst case scenario specification.

- If a single fan fails, the remaining fans in the row compensate with increased speed.

- If two or more fans fail, the entire fan tray operates at full speed after one minute. Further, the fan tray must be replaced. The individual fans are not field replaceable, you must replace the fan tray.
- If the temperature sensor fails or communication with the temperature sensor fails, the worst case operating temperature is assumed.
- If the pressure sensor fails or communication with the pressure sensor fails, the worst case operating pressure is assumed.

Thresholds, Alarms, and Abnormal Acoustic Conditions

Under normal operating conditions, when none of the temperature alarms have been triggered, hardware controls fan speed. If any of the system temperature alarms are triggered, software displays a syslog message indicating that the temperature is high and the fans are operating at higher speed. Refer to the *System Management* section of the software configuration guide for more information.

In case of a fan failure, you must replace the fan tray within 120 seconds or power down the system. If the temperature exceeds the shutdown threshold, software powers the system down.

When the fan tray operates at full speed, increased noise levels may be expected. The fan tray may operate at full speed in these circumstances:

- If two or more fans have failed
- If the STATUS LED remains red for more than one minute
- If there is a hardware failure
- If the software watchdog timer is triggered

Power Supply Module Overview

The switch chassis has four redundant power supply slots that operate with one to four power supply modules. The chassis supports field-replaceable AC-input and DC-input power supply modules.

The power supply modules generate 12Vdc output power and distributes it to the line cards and supervisor modules. The power supplies distribute power to all slots using an internal bus-bar based power distribution mechanism. All power supply modules have internal fans and support front-to-rear airflow.

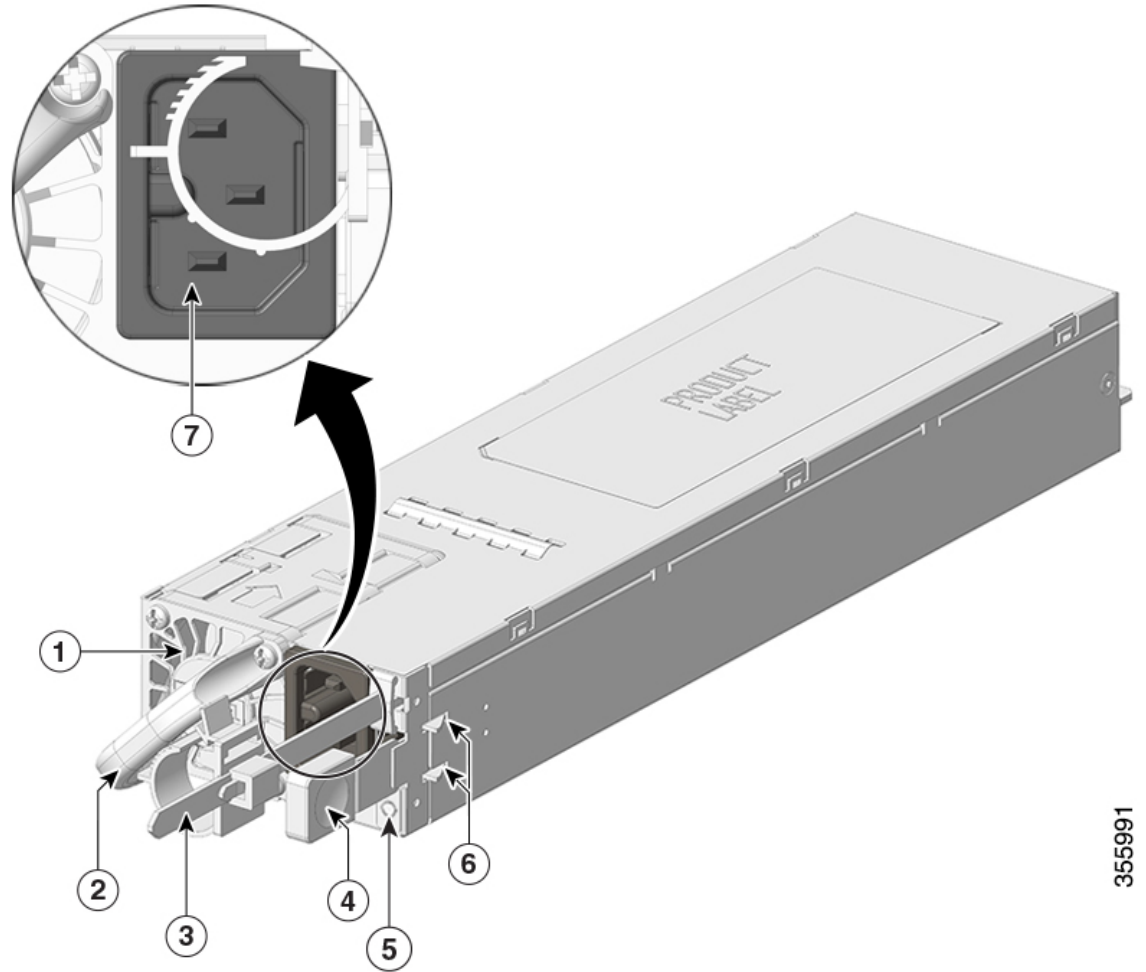
The following are the supported power supply modules:

Table 2: Power Supply Modules Supported on Cisco Catalyst 9600 Series Switches

Part Number	Description
C9600-PWR-2KWAC (=)	Cisco Catalyst 9600 Series 2000W AC Power Supply
C9600-PWR-2KWDC (=)	Cisco Catalyst 9600 Series 2000W DC Power Supply

AC Power Supply Module

Figure 4: Cisco Catalyst 9600 Series 2000W AC Power Supply



1	PSU fan	5	Status LED
2	Release handle	6	Retainer clips
3	Power cord retainer	7	Power cord connector
4	Release latch	-	-

The following are the features supported by a Cisco Catalyst 9600 Series AC power supply module:

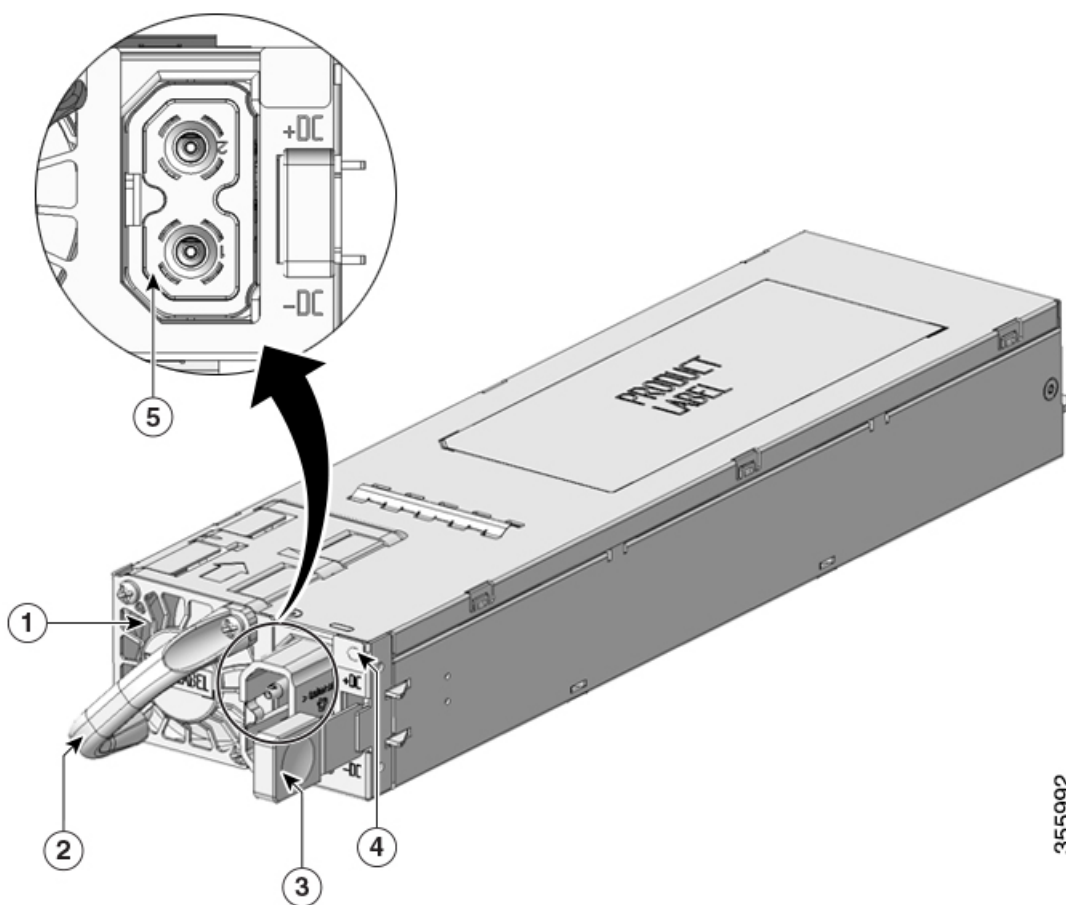
- Self-cooling, with a minimum airflow of 17 cubic feet per minute (CFM) at 100 percent load.
- Supports only single-phase source AC. Source AC can be out of phase between multiple power supplies or multiple AC-power plugs on the same power supply because all AC power supply inputs are isolated.
- Has a release latch and cord-retention mechanism on the front panel of the module, to avoid accidental removal of the module or the attached power cord.

- Supports redundant and combined configuration modes. A single (non-redundant) or a dual (redundant) power supply configuration, can support the following loads:

Input Voltage (VAC)	Output Power in Watts
220VAC	2000W
110VAC	1050W

DC Power Supply Module

Figure 5: Cisco Catalyst 9600 Series 2000W DC Power Supply



3555992

1	PSU fan	4	LED
2	Release handle	5	Power cord connector
3	Release latch	-	-

The following are the features supported by a Cisco Catalyst 9600 Series DC power supply module:

- Self-cooling, with a minimum airflow of 9.5 cubic feet per minute (CFM) at 100 percent load.
- Has a release latch mechanism on the side of the module, to avoid accidental removal of the module.
- Has DC-input reversal protection such that the unit will survive this condition up to the full input voltage rating.
- Supports redundant and combined configuration modes. A single (non-redundant) or a dual (redundant) power supply configuration, can support the following loads:

Input Voltage (VDC)	Output Power
-40 to -72VDC (with extended range to -75VDC) Voltage differential between inputs is unlimited.	2000W

Power Supply Modes

Cisco Catalyst 9600 Series Switches offer redundant and combined configuration modes for power supplies. In both the modes, the power supplies will share the load equally.

The number of power supply modules installed and the system load determine the power-level that the system expects to draw from each power supply module and consequently, the power supply mode that will be suitable. For system power budgeting estimates and to determine power supply requirements, use the [Cisco Power Calculator](#).

To configure a power supply mode, enter the **power redundancy-mode** command in global configuration mode. If you do not configure a mode, the default mode applies.

Combined Mode

This is the default power supply mode.

The system operates with one to four power supply modules. The power available to the system is the sum of power outputs of all the power supply modules in the chassis multiplied by the share ratio. All available power supply modules are active and sharing power, and can operate at up to 100 percent capacity. Additional power supply units operate at 97 percent capacity. In combined mode, you can use a combination of AC and DC power supplies provided the AC input voltage is 220V and that the power supplies are of equal wattage. However, you cannot combine two AC power supplies of 110V input and 220V input.

Total combined mode power = $P + (N-1) * P * (\text{share ratio})$

where P = Power output of one of the power supply units and N is the number of power supply modules used.



Warning

In case of failure in the combined mode, each operational power supply increases its output. If the output power does not meet system requirements, then all the operational power supply modules may be overloaded and go into overcurrent shutdown. All system power is then lost.

The following table provides details about the power output in combined mode:

Input voltage	One Power Supply	Two Power Supplies	Three Power Supplies	Four Power Supplies
110V	1050W	2040W	3030W	4020W
220V	2000W	3940W	5880W	7820W

Redundant (N+1) Mode

In a redundant configuration, a given power supply module can either be active, or in standby mode. In N+1 redundant mode, N is the number of active power supply modules and +1 is the power supply module configured as the standby module.

You can configure redundancy mode in the software. When the switch is configured with N+1 redundancy, software ensures that there is a standby power supply available and there is sufficient power available with the active power supply modules (N). All the power supplies including active and standby will share the load equally. However, with a standby power supply installed, system ensures that the additional output power available with a standby is always reserved for use in case of a failure. If the power supply mode is set to redundant mode and the total active output power is not sufficient to meet the power requirements, the switch will not enter the redundant mode.

You can use a combination of AC and DC power supplies provided the AC input voltage is 220V and the power supplies must be of equal wattage. However, you cannot combine two AC power supplies of 110V input and 220V input.

The following table provides details about the power output in N+1 redundant mode:

Input voltage	Two Power Supplies	Three Power Supplies	Four Power Supplies
110V	1050W	2040W	3030W
220V	2000W	3940W	5880W

For detailed software configuration information, see the required version of the *Software Configuration Guide*. In the guide, go to *Contents* → *System Management* → *Environmental Monitoring and Power Management*.



CHAPTER 2

Preparing for Installation

- [Safety Warnings, on page 11](#)
- [Site Requirements, on page 14](#)
- [Power Requirements, on page 23](#)
- [Cabling Requirements, on page 23](#)
- [Rack-Mounting Guidelines, on page 24](#)
- [Site Preparation Checklist, on page 25](#)

Safety Warnings

Safety warnings appear throughout this publication in procedures that may harm you if you perform them incorrectly. A warning symbol precedes each warning statement. The warnings below are general warnings that are applicable to the entire publication.



Warning

An exposed wire lead from a DC-input power source can conduct harmful levels of electricity. Be sure that no exposed portion of the DC-input power source wire extends from the connector(s) or terminal block(s). **Statement 122**



Warning

AC connected units must have a permanent ground connection in addition to the power cable ground wire. NEBS-compliant grounding satisfies this requirement. **Statement 284**



Warning

High leakage current—earth connection essential before connecting to system power supply. **Statement 342**



Warning

Power Cable and AC Adapter - When installing the product, please use the provided or designated connection cables/power cables/AC adaptors. Using any other cables/adaptors could cause a malfunction or a fire. Electrical Appliance and Material Safety Law prohibits the use of UL-certified cables (that have the "UL or CSA" shown on the code) for any other electrical devices than products designated by CISCO. The use of cables that are certified by Electrical Appliance and Material Safety Law (that have "PSE" shown on the code) is not limited to CISCO-designated products. **Statement 371**



Warning To reduce the risk of electric shock, the chassis of this equipment needs to be connected to permanent earth ground during normal use. **Statement 0445**



Warning Read the installation instructions before using, installing or connecting the system to the power source. **Statement 1004**



Warning Class 1 laser product. **Statement 1008**



Warning There is the danger of explosion if the battery is replaced incorrectly. Replace the battery only with the same or equivalent type recommended by the manufacturer. Dispose of used batteries according to the manufacturer's instructions. **Statement 1015**



Warning This unit is intended for installation in restricted access areas. A restricted access area can be accessed only through the use of a special tool, lock and key, or other means of security. **Statement 1017**



Warning This equipment must be grounded. Never defeat the ground conductor or operate the equipment in the absence of a suitably installed ground conductor. Contact the appropriate electrical inspection authority or an electrician if you are uncertain that suitable grounding is available. **Statement 1024**



Warning Class 1 LED product. **Statement 1027**



Warning Blank faceplates and cover panels serve three important functions: they prevent exposure to hazardous voltages and currents inside the chassis; they contain electromagnetic interference (EMI) that might disrupt other equipment; and they direct the flow of cooling air through the chassis. Do not operate the system unless all cards, faceplates, front covers, and rear covers are in place. **Statement 1029**



Warning Only trained and qualified personnel should be allowed to install, replace, or service this equipment. **Statement 1030**



Warning Hazardous voltage or energy is present on the backplane when the system is operating. Use caution when servicing. **Statement 1034**



Warning Ultimate disposal of this product should be handled according to all national laws and regulations. **Statement 1040**



Warning To prevent the system from overheating, do not operate it in an area that exceeds the maximum recommended ambient temperature of 104°F (40°C). **Statement 1047**



Warning Stability hazard. The rack stabilizing mechanism must be in place, or the rack must be bolted to the floor before you slide the unit out for servicing. Failure to stabilize the rack can cause the rack to tip over. **Statement 1048**



Warning The chassis should be mounted on a rack that is permanently affixed to the building. **Statement 1049**



Warning Invisible laser radiation may be emitted from disconnected fibers or connectors. Do not stare into beams or view directly with optical instruments. **Statement 1051**



Warning Class 1M laser radiation when open. Do not view directly with optical instruments. **Statement 1053**



Warning Class I (CDRH) and Class 1M (IEC) laser products. **Statement 1055**



Warning Invisible laser radiation may be emitted from the end of the unterminated fiber cable or connector. Do not view directly with optical instruments. Viewing the laser output with certain optical instruments (for example, eye loupes, magnifiers, and microscopes) within a distance of 100 mm may pose an eye hazard. **Statement 1056**

Fiber type and Core diameter (µm)	Wavelength (nm)	Max. Power (mW)	Beam divergence (rad)
SM 11	1200 - 1400	39 - 50	0.1 - 0.11
MM 62.5	1200 - 1400	150	0.18 NA
MM 50	1200 - 1400	135	0.17 NA
SM 11	1400 - 1600	112 - 145	0.11 - 0.13

3-49377

**Warning****IMPORTANT SAFETY INSTRUCTIONS**

This warning symbol means danger. You are in a situation that could cause bodily injury. Before you work on any equipment, be aware of the hazards involved with electrical circuitry and be familiar with standard practices for preventing accidents. Use the statement number provided at the end of each warning to locate its translation in the translated safety warnings that accompanied this device. Statement 1071

SAVE THESE INSTRUCTIONS**Warning**

The covers are an integral part of the safety design of the product. Do not operate the unit without the covers installed. **Statement 1077**

Site Requirements

Planning a proper location for the switch and layout of the equipment rack or wiring closet is essential for successful system operation. These sections describe some of the basic site requirements that you should be aware of as you prepare to install your switch, including the following:

- Environmental factors can adversely affect the performance and longevity of your system.
- Install the switch in an enclosed, secure area, ensuring that only qualified personnel have access to the switch and control of the environment.
- Equipment that is placed too closely together or that is inadequately ventilated may cause system over-temperature conditions, leading to premature component failure.
- Poor equipment placement can make chassis panels inaccessible and difficult to maintain.
- The switch requires a dry, clean, well-ventilated, and air-conditioned environment.
- To ensure normal operation, maintain ambient airflow. If the airflow is blocked or restricted, or if the intake air is too warm, an over-temperature condition may occur. The switch environmental monitor may then shut down the system to protect the system components.
- Multiple switches can be rack mounted with little or no clearance above and below the chassis. However, when mounting a switch in a rack with other equipment, or when placing it on the floor near other equipment, ensure that the exhaust from other equipment does not blow into the air intake vent of the switch chassis.

Temperature

Temperature extremes may cause a system to operate at reduced efficiency and cause a variety of problems, including premature aging and failure of chips, and failure of mechanical devices. Extreme temperature fluctuations may also cause chips to become loose in their sockets. Observe the following guidelines:

- Ensure that the system is operating in an environment that is—
 - 23 to 113 °F (-5 to 45 °C) up to 6000 feet (1800m)

- 23 to 104 °F (-5 to 40 °C) up to 10000 feet (3000m)
- Ensure that the chassis has adequate ventilation.
- Do not place the chassis within a closed-in wall unit or on top of cloth, which can act as insulation.
- Do not place the chassis where it will receive direct sunlight, particularly in the afternoon.
- Do not place the chassis next to a heat source of any kind, including heating vents.
- Adequate ventilation is particularly important at high altitudes. Make sure that all the slots and openings on the system remain unobstructed, especially the fan vent on the chassis.
- Clean the installation site at regular intervals to avoid buildup of dust and debris, which may cause a system to overheat.
- If system is exposed to abnormally low temperatures, allow a two hour warm up period, in ambient temperature no lower than 32°F (0 °C) before turning on.

**Warning**

Do not operate the system if the fan assembly is removed or if it is not functioning properly. An overtemperature condition can cause severe equipment damage or an unscheduled system shutdown.

Failure to observe these guidelines may damage the chassis' internal components.

Air Flow

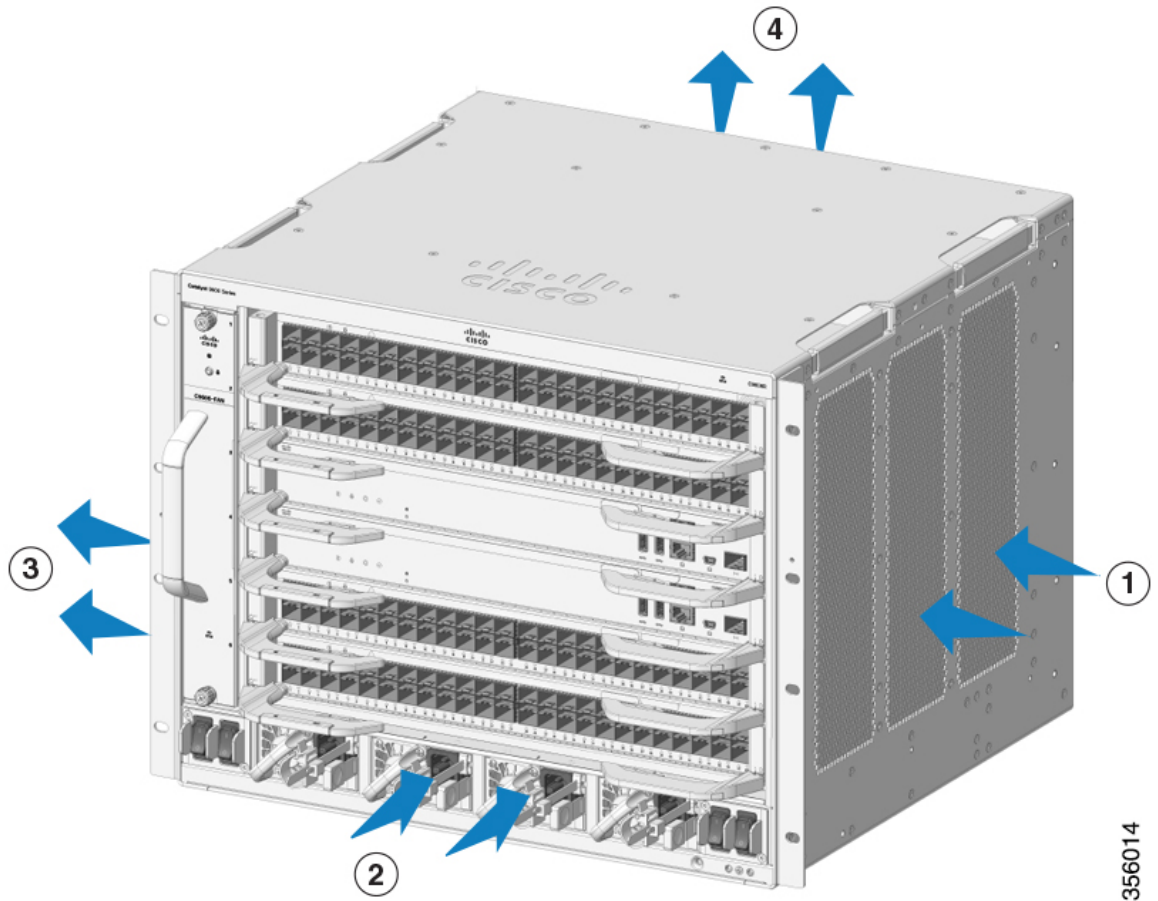
The switch is designed to be installed in an environment where there is a sufficient volume of air available to cool the supervisor engines, modules, and power supplies. If there are any constraints with regard to the free flow of air through the chassis, or if the ambient air temperature is elevated, the switch environmental monitor may then shut down the system to protect the system components.

To maintain proper air circulation through the switch chassis, we recommend that you maintain a minimum space of 6 inches (15 cm) between a wall and the chassis and power supply unit air intakes or a wall and the chassis and power supply unit hot air exhausts. In situations where the switch chassis are installed in adjacent racks, you should allow a minimum space of 12 inches (30.5 cm) between the air intake of one chassis and the hot air exhaust of another chassis.

**Note**

Failure to maintain adequate spacing between chassis may cause the switch chassis that is drawing in the hot exhaust air to overheat and fail.

Figure 6: Air Flow Direction - Cisco Catalyst 9600 Series Switches



1	Chassis air intake	3	Chassis air exhaust
2	Power supply air intake	4	Power supply air exhaust

If you are installing your switch in an enclosed or partially enclosed rack, we strongly recommend that you verify that your site meets the following guidelines:

- Verify that there is a minimum of 6 inches (15 cm) of clearance between the sides, front, and back of any enclosure, and both the chassis air intake grill and the chassis air exhaust grill along with the power supply unit intakes and exhausts. The upright columns of a relay rack may be located less than the recommended side spacing provided there are substantial cutouts, holes, or vents in the structure to allow adequate air flow through the chassis.
- Verify that the ambient air temperature within the enclosed or partially enclosed rack is within the chassis operating temperature limits. After installing the chassis in the rack, power up the chassis and allow the chassis temperature to stabilize (approximately 2 hours).

Measure the ambient air temperature at the chassis air intake grill by positioning an external temperature probe 1 inch (2.5 cm) away from the chassis left side, and centered on the chassis both horizontally and vertically.

Measure the ambient air temperature at the power supply unit air intake grill by positioning an external temperature probe 1 inch (2.5 cm) away from the chassis front, centered on the power supply unit section located above the card slots.

- If the ambient intake air temperature is less than 113°F (45°C) at altitudes of 6,000 feet and below, the rack meets the intake air temperature criterion. At altitudes above that threshold and up to 10,000 feet (3000 m), the air intake should not exceed 104°F (40°C).
 - If the ambient intake air temperature exceeds this recommendation, the system may experience minor temperature alarms and increase fan speeds in response.
 - If the ambient intake air temperature equals or is greater than 131°F (55°C), the system may experience a major temperature alarm with maximum fan speeds in response. If ambient temperature continues to increase, system will respond with protective shut down.
- Plan ahead. A switch that is currently installed in an enclosed or partially enclosed rack might meet ambient air temperature and air flow requirements at present. However, if you add more chassis to the rack or more modules to a chassis in the rack, the additional heat generated might cause the ambient air temperature at the chassis or power supply unit inlets to exceed recommended conditions which may trigger thermal alarms.

Humidity

High-humidity conditions may cause moisture to enter the system, and cause corrosion of internal components and degradation of properties such as electrical resistance, thermal conductivity, physical strength, and size. Extreme moisture buildup inside the system may result in electrical short circuit, which may cause serious damage to the system. Each system is rated for storage and operation in 10 to 95 percent relative humidity, non-condensing with a humidity gradation of 10 percent per hour. Buildings in which climate is controlled by air-conditioning in the warmer months and by heat during the colder months usually maintain an acceptable level of humidity for system equipment. However, if a system is located in an unusually humid location, a dehumidifier should be used to maintain the humidity within an acceptable range.

Altitude

Operating a system at high altitude (low pressure) reduces the efficiency of forced and convection cooling and may result in electrical problems related to arcing and corona effects. This condition may also cause sealed components with internal pressure, such as electrolytic capacitors, to fail or perform at reduced efficiency.

Dust and Particles

Fans cool power supplies and system components by drawing in room-temperature air and exhausting heated air out through various openings in the chassis. However, fans also ingest dust and other particles, causing contaminant buildup in the system and increased internal chassis temperature. A clean operating environment can greatly reduce the negative effects of dust and other particles, which act as insulators and interfere with the mechanical components in the system. The standards listed below provide guidelines for acceptable working environments and acceptable levels of suspended particulate matter:

- National Electrical Manufacturers Association (NEMA) Type 1
- International Electrotechnical Commission (IEC) IP-20

Corrosion

Corrosion of system connectors is a gradual process that may eventually lead to intermittent failures of electrical circuits. The oil from a person's fingers or prolonged exposure to high temperature or humidity may corrode the gold-plated edge connectors and pin connectors on various components in the system. To prevent corrosion, avoid touching contacts on boards and cards, and protect the system from extreme temperatures and moist, salty environments.

EMI and Radio Frequency Interference

Electro-Magnetic interference (EMI) and radio frequency interference (RFI) from a system can adversely affect devices such as radio and television (TV) receivers operating near the system. Radio frequencies emanating from a system can also interfere with cordless and low-power telephones. Conversely, RFI from high-power telephones can cause spurious characters to appear on the system monitor. RFI is defined as any EMI with a frequency above 10 kilohertz (kHz). This type of interference can travel from the system to other devices through the power cable and power source, or through the air in the form of transmitted radio waves. The Federal Communications Commission (FCC) publishes specific regulations to limit the amount of EMI and RFI emitted by computing equipment. Each system meets these FCC regulations. To reduce the possibility of EMI and RFI, follow these guidelines:

- Always operate the system with the chassis covers installed.
- Ensure that all chassis slots are covered by a metal filler bracket and that an unused power supply bay has a metal cover plate installed.
- Ensure that the screws on all peripheral cable connectors are securely fastened to their corresponding connectors on the back of the chassis.
- Always use shielded cables with metal connector shells for attaching peripherals to the system.

When wires are run for any significant distance in an electromagnetic field, interference can occur between the field and the signals on the wires. This fact has two implications for the construction of plant wiring:

- Bad wiring practice can result in radio interference emanating from the plant wiring.
- Strong EMI, especially when it is caused by lightning or radio transmitters, can destroy the signal drivers and receivers in the chassis, and even create an electrical hazard by conducting power surges through lines into equipment.



Note To predict and provide a remedy for strong EMI, consult experts in RFI.

If you use twisted-pair cable in your plant wiring with a good distribution of grounding conductors, the plant wiring is unlikely to emit radio interference. If you exceed the recommended distances, use a high-quality twisted-pair cable with one ground conductor for each data signal when applicable.



Caution Category 5e, Category 6, and Category 6a cables can store large levels of static electricity because of the dielectric properties of the materials used in their construction. Always ground the cables (especially in new cable runs) to a suitable and safe earth ground before connecting them to the module.

If the wires exceed the recommended distances, or if wires pass between buildings, give special consideration to the effect of a lightning strike in your vicinity. The electromagnetic pulse caused by lightning or other high-energy phenomena can easily couple enough energy into unshielded conductors to destroy electronic devices. If you have had problems of this sort in the past, you may want to consult experts in electrical surge suppression and shielding.

**Warning**

The intra-building ports (Copper Based Ethernet Ports) of the equipment or subassembly is suitable for connection to intra-building or unexposed wiring or cabling only. The intra-building ports of the equipment or subassembly **MUST NOT** be metalically connected to interfaces that connect to the Out Side Plant (OSP) or its wiring for more than 6 meters (approximately 20 feet). These interfaces are designed for use as intra-building interfaces only (Type 2, 4, or 4a ports as described in GR-1089) and require isolation from the exposed OSP cabling. The addition of Primary Protectors is not sufficient protection in order to connect these interfaces metalically to an OSP wiring system.

Shock and Vibration

The equipment complies with the Earthquake, Office, and Transportation Vibration, and Equipment Handling Criteria of GR-63-CORE.

Power Source Interruptions

Systems are especially sensitive to variations in voltage supplied by the AC power source. Overvoltage, undervoltage, and transients (or spikes) can erase data from memory or even cause components to fail. To protect against these types of problems, power cables should always be properly grounded. Also, place the system on a dedicated power circuit (rather than sharing a circuit with other heavy electrical equipment). In general, do not allow the system to share a circuit with any of the following:

- Copy machines
- Air conditioners
- Vacuum cleaners
- Space heaters
- Power tools
- Teletype machines
- Laser printers
- Facsimile machines
- Any other motorized equipment

Besides these appliances, the greatest threats to a system's power supply are surges or blackouts that are caused by electrical storms. Whenever possible, turn off the system and peripherals, if any, and unplug them from their power sources during thunderstorms. If a blackout occurs—even a temporary one—while the system is turned on, turn off the system immediately and disconnect it from the electrical outlet. Leaving the system on may cause problems when the power is restored; all other appliances left on in the area may create large voltage spikes that may damage the system.

System Grounding



Warning When installing or replacing the unit, the ground connection must always be made first and disconnected last. **Statement 1046**



Warning Use copper conductors only. **Statement 1025**

You must install a system ground as part of the chassis installation process. Chassis installations that rely only on the AC third-prong ground are insufficient to adequately ground the systems.

Proper grounding practices ensure that the buildings and the installed equipment within them have low-impedance connections and low-voltage differentials between chassis. When you install a system ground, you reduce or prevent shock hazards, chances of equipment damage due to transients, and the potential for data corruption.

Without proper and complete system grounding, you run the risk of increased component damage due to ESD. Additionally, you have a greatly increased chance of data corruption, system lockup, and frequent system reboot situations by not using a system ground.



Caution Installations that rely solely on system grounding that uses only an AC third-prong ground run a substantially greater risk of equipment problems and data corruption than those installations that use both the AC third-prong ground and a properly installed system ground.

The following table lists some general grounding practice guidelines.

Table 3: Grounding Practice Guidelines

Environment	Electromagnetic Noise Severity Level	Grounding Recommendations
Commercial building is subjected to direct lightning strikes. For example, some places in the United States, such as Florida, are prone to more lightning strikes than other areas.	High	All lightning protection devices must be installed in strict accordance with manufacturer recommendations. Conductors carrying lightning current should be spaced away from power and data lines in accordance with applicable recommendations and codes. Best grounding practices must be closely followed.
Commercial building is located in an area where lightning storms occur frequently, but is not prone to direct lightning strikes.	High	Best grounding practices must be closely followed.

Environment	Electromagnetic Noise Severity Level	Grounding Recommendations
Commercial building contains a mix of information technology equipment and industrial equipment, such as welding.	Medium to High	Best grounding practices must be closely followed.
Existing commercial building is not subject to natural environmental noise or man-made industrial noise. This building contains a standard office environment. This installation has a history of malfunction due to electromagnetic noise.	Medium	Best grounding practices must be closely followed. Determine source and cause of noise if possible, and mitigate as closely as possible at the noise source or reduce coupling from the noise source to the victim equipment.
New commercial building is not subject to natural environmental noise or man-made industrial noise. This building contains a standard office environment.	Low	Best grounding practices should be followed as closely as possible. Electromagnetic noise problems are not anticipated, but installing a best-practice grounding system in a new building is often the least expensive route, and the best way to plan for the future.
Existing commercial building is not subject to natural environmental noise or man-made industrial noise. This building contains a standard office environment.	Low	Best grounding practices should be followed as much as possible. Electromagnetic noise problems are not anticipated, but installing a best-practice grounding system is always recommended.



Note In all situations, grounding practices must comply with Section 250 of the National Electric Code (NEC) requirements or local laws and regulations. A 6 AWG grounding wire is preferred from the chassis to the rack ground or directly to the common bonding network (CBN). The equipment rack should also be connected to the CBN with a 6 AWG grounding wire.



Note Always ensure that all of the modules are completely installed and that the captive installation screws are fully tightened. In addition, ensure that all the I/O cables and power cords are properly seated. These practices are normal installation practices and must be followed in all installations.



Caution Category 5e, Category 6, and Category 6a cables can store large levels of static electricity because of the dielectric properties of the materials used in their construction. Always ground the cables (especially in new cable runs) to a suitable and safe earth ground before connecting them to the module.

Maintaining Safety with Electricity

When working on electrical equipment, follow these guidelines:

- Do not work alone if potentially hazardous conditions exist anywhere in your work space.
- Never assume that power is disconnected from a circuit; always check the circuit before working on it.
- Look carefully for possible hazards in your work area, such as damp floors, ungrounded power extension cables, frayed or damaged power cords, and missing safety grounds.
- If an electrical accident occurs, proceed as follows:
 - Use extreme caution; do not become a victim yourself.
 - Disconnect power from the system.
 - Seek medical attention, if necessary.
- Use the product within its marked electrical ratings and product usage instructions.
- Install the product in compliance with local and national electrical codes.
- If any of the following conditions occur, contact the Cisco Technical Assistance Center:
 - The power cable or plug is damaged.
 - An object has fallen into the product.
 - The product has been exposed to water or other liquids.
 - The product has been dropped or shows signs of damage.
 - The product does not operate correctly when you follow the operating instructions.
- Use the correct external power source. Operate the product only from the type of power source indicated on the electrical ratings label. If you are not sure of the type of power source required, consult a local electrician.
- Use approved power cables only. You have been provided with one or more power cables with your chassis power supply that are intended for use in your country, based on the shipping location. Should you need to purchase additional power cables, ensure that they are rated for the product and for the voltage and current marked on the product's electrical ratings label. The voltage and current rating of the power cable should be greater than the ratings marked on the label.
- To help prevent electrical shock, plug all the power cables into properly grounded electrical outlets. These power cables are equipped with three-prong plugs to ensure proper grounding. Do not use adapter plugs or remove the grounding prong from a power cable.
- Observe power strip ratings. Make sure that the total current rating of all products that are plugged into the power strip does not exceed 80 percent of the power strip rating.
- Do not modify power cables or plugs yourself. Consult with a licensed electrician or your power company for site modifications. Always follow your local and national wiring codes.

Preventing ESD Damage

ESD damage might occur when modules or other FRUs are improperly handled, resulting in intermittent or complete failure of the modules or FRUs. Modules consist of printed circuit boards that are fixed in metal carriers. EMI shielding and connectors are integral components of a carrier. Although the metal carrier helps to protect the board from ESD, always use an ESD-grounding strap when handling modules. To prevent ESD damage, follow these guidelines:

- Always use an ESD wrist or ankle strap and ensure that it makes good skin contact.
- Connect the equipment end of the strap to an unfinished chassis surface.
- When installing a component, use an available ejector lever to properly seat the bus connectors in the backplane or midplane. These devices prevent accidental removal, provide proper grounding for the system, and help to ensure that bus connectors are properly seated.
- When removing a component, use an available ejector lever to release the bus connectors from the backplane or midplane.
- Handle carriers by available handles or edges only; avoid touching the printed circuit boards or connectors.
- Place a removed component board-side-up on an antistatic surface or in a static-shielding container. If you plan to return the component to the factory, immediately place it in a static-shielding container.
- Avoid contact between the printed circuit boards and clothing. The wrist strap only protects components from ESD voltages on the body; ESD voltages on clothing can still cause damage.
- Never attempt to remove the printed circuit board from the metal carrier.

Power Requirements

Power supplies installed on the switch chassis can be all AC-input, all DC-input, or a mix of both. When preparing your site for switch installation, adhere to these requirements:

- In systems configured with more than one power supply, connect each of the power supplies to a separate input power source. If you fail to do this, your system might be susceptible to total power failure due to a fault in the external wiring or a tripped circuit breaker
- To prevent loss of input power, be sure that the total maximum load on each source circuit is within the current ratings of the wiring and breakers.
- In some systems, you may decide to use an uninterruptible power supply (UPS) to protect against power failures at your site. Be aware when selecting a UPS that some UPS models that use ferroresonant technology may become unstable when operating with the switch power supplies that use power factor correction. This may cause the output voltage waveform to the switch to become distorted, resulting in an undervoltage situation in the system.

Cabling Requirements

When running power and data cables together in overhead cable trays or subfloor cable trays, be aware of the following caution:

**Caution**

We strongly recommend that power cabling runs and other potential noise sources be located as far away as practical from LAN cabling that terminates on Cisco equipment. In situations where this type of long parallel cable runs exist and cannot be separated by at least 3.3 feet (1 meter), we recommend that you shield these potential noise sources. To avoid interference, the source should be shielded by housing it in a grounded metallic conduit.

Also be aware of the following caution concerning the use of Category 5e and Category 6 Ethernet cables:

**Caution**

Category 5e, Category 6, and Category 6a cables can store large levels of static electricity because of the dielectric properties of the materials used in their construction. Always ground the cables (especially in new cable runs) to a suitable and safe earth ground before connecting them to the module.

Rack-Mounting Guidelines

Rack Specifications

Cisco Catalyst 9600 Series Switches are designed to be installed in standard, 19-inch equipment racks that meet EIA-310-D specifications. In Network Equipment Building Systems (NEBS) compliant installation, you can use only a 23-inch rack mount. Before rack-mounting the chassis, ensure that the equipment rack complies with all requirements and guidelines

Mounting Location Guidelines

Cisco Catalyst 9600 Series Switches must be front-mounted.

Accordingly, you can install the chassis in 2-post or 4-post racks, but in a 4-post rack, the rear posts are not used for mounting.

Width and Depth Requirements

Use a tape measure to verify the interior dimensions of the rack.

- Measure the space between the inner edges of the left front and right front mounting posts. The chassis is 19 inches (48.26 cm) wide and must fit between the mounting posts.
- Measure the depth of the rack from the outside of the front mounting posts to the outside of the rear mounting strip. The chassis is 18.8 inches (47.75 cm) deep.

Height Requirements

The rack must have sufficient clearance in terms of height, to insert the chassis. Chassis height is also measured in rack units (RU or just U) where 1 RU or 1 U equals 1.75 inches (44.45 mm). A typical server rack is 42 RU or 42 U in height.

The chassis height of Catalyst 9606R Switch is 8 RU with a depth of 18.8 inches.

Other General Guidelines



Caution If the equipment rack is on wheels, ensure that the brakes are engaged and that the rack is stabilized.



Warning To prevent bodily injury when mounting or servicing this unit in a rack, you must take special precautions to ensure that the system remains stable. The following guidelines are provided to ensure your safety:

- This unit should be mounted at the bottom of the rack if it is the only unit in the rack.
- When mounting this unit in a partially filled rack, load the rack from the bottom to the top with the heaviest component at the bottom of the rack.
- If the rack is provided with stabilizing devices, install the stabilizers before mounting or servicing the unit in the rack. **Statement 1006**



Warning Take care when connecting units to the supply circuit so that wiring is not overloaded. **Statement 1018**



Warning To prevent the system from overheating, do not operate it in an area that exceeds the maximum recommended ambient temperature of: 104° F (40°C) **Statement 1047**



Note To maintain proper air circulation through the switch chassis, we recommend that you maintain a minimum space of 6 inches (15 cm) between a wall and the chassis and power supply unit air intakes or a wall and the chassis and power supply unit hot air exhausts. In situations where the switch chassis are installed in adjacent racks, you should allow a minimum space of 12 inches (30.5 cm) between the air intake of one chassis and the hot air exhaust of another chassis. Failure to maintain adequate spacing between chassis may cause the switch chassis that is drawing in the hot exhaust air to overheat and fail.

Site Preparation Checklist

The following table lists the site-planning activities that you should perform prior to installing the switch. Completing each activity helps ensure a successful switch installation.

Table 4: Site Preparation Checklist

Task No.	Activity	Verified By	Time	Date
1	Space evaluation <ul style="list-style-type: none"> • Space and layout • Floor covering • Impact and vibration • Lighting • Maintenance access 			
2	Environmental evaluation <ul style="list-style-type: none"> • Ambient temperature • Humidity • Altitude • Atmospheric contamination • Airflow 			
3	Power evaluation <ul style="list-style-type: none"> • Input power type • Power receptacles (Depends on power supply)² • Receptacle proximity to the equipment. • Dedicated (separate) circuits for redundant power supplies. • UPS for power failures³ 			
4	Grounding evaluation <ul style="list-style-type: none"> • Circuit breaker size • CO ground (AC powered systems) 			
5	Cable and interface equipment evaluation <ul style="list-style-type: none"> • Cable type • Connector type • Cable distance limitations • Interface equipment (transceivers) • Cable bundling sizes 			

Task No.	Activity	Verified By	Time	Date
6	EMI evaluation <ul style="list-style-type: none"> • Distance limitations for signaling • Site wiring • RFI levels 			

- ² Verify that each power supply installed in the chassis has a dedicated AC source circuit.
- ³ Refer to the power supply VA rating as a sizing criteria in determining the output required by the UPS. The power supply kVA rating value is listed in the specifications table for each power supply in Appendix A (power supply specifications).



CHAPTER 3

Installing the Switch

- [Unpacking the Switch, on page 29](#)
- [Install the Switch as Shipped, on page 30](#)
- [Install the Switch with Shelf Brackets, on page 36](#)
- [Install the Switch in NEBS-Compliant Mode, on page 50](#)
- [Establishing System Ground, on page 57](#)
- [Attaching an ESD Strap, on page 60](#)
- [Verifying the Switch Chassis Installation, on page 61](#)

Unpacking the Switch

Check the contents of the shipping container:

Procedure

- Step 1** Check the contents of the accessory kit. Verify that you have received all the listed equipment, including any optional equipment you may have ordered, such as, network interface cables, transceivers, or special connectors.
- Step 2** Check the modules in each slot. Ensure that the configuration matches the packing list and that all of the specified interfaces are included.
- Step 3** Store the shipping carton.
- Tip** Do not discard the shipping container when you unpack the switch. Flatten the shipping cartons and store them with the pallet. You will require these containers if you have to move or ship the switch in the future.
-

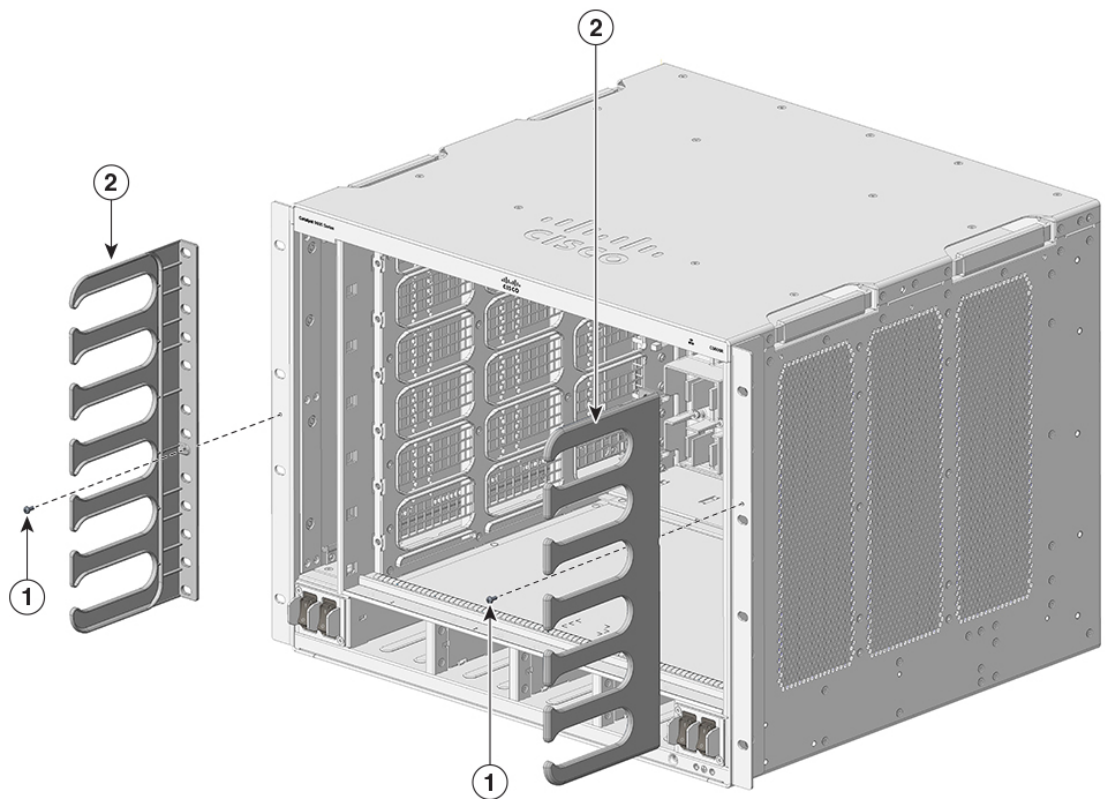
Install the Switch as Shipped

Installing the Cable Guide on the Chassis with L-Brackets Preinstalled on the Chassis

Procedure

- Step 1** Position the cable guides to align with the L-brackets preinstalled on the chassis and secure the cable guides to the L-brackets using the screws provided.

Figure 7: Attaching the Cable Guides

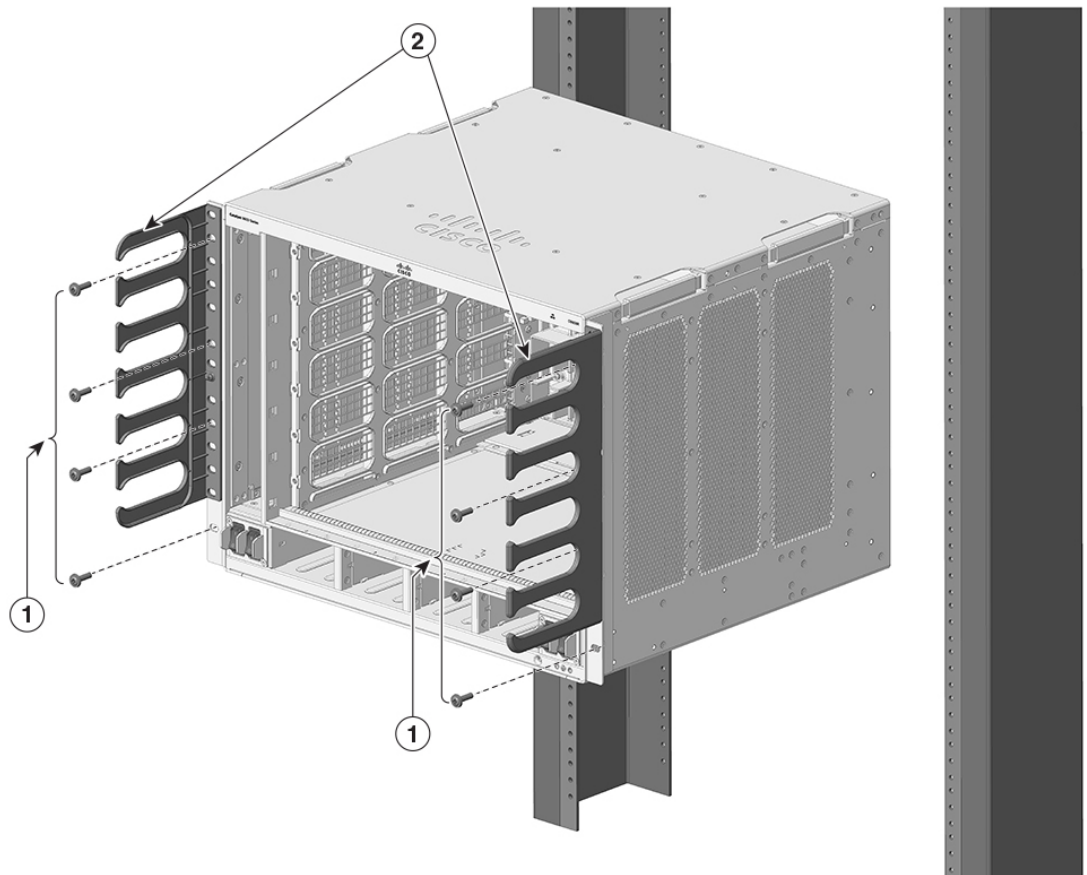


356054

1	Screws to attach the cable guides to the L-brackets on the chassis	2	Cable guides
---	--------------------------------------------------------------------	---	--------------

- Step 2** Secure the chassis to the rack rails with four screws on each side.

Figure 8: Mounting the Chassis to the Rack

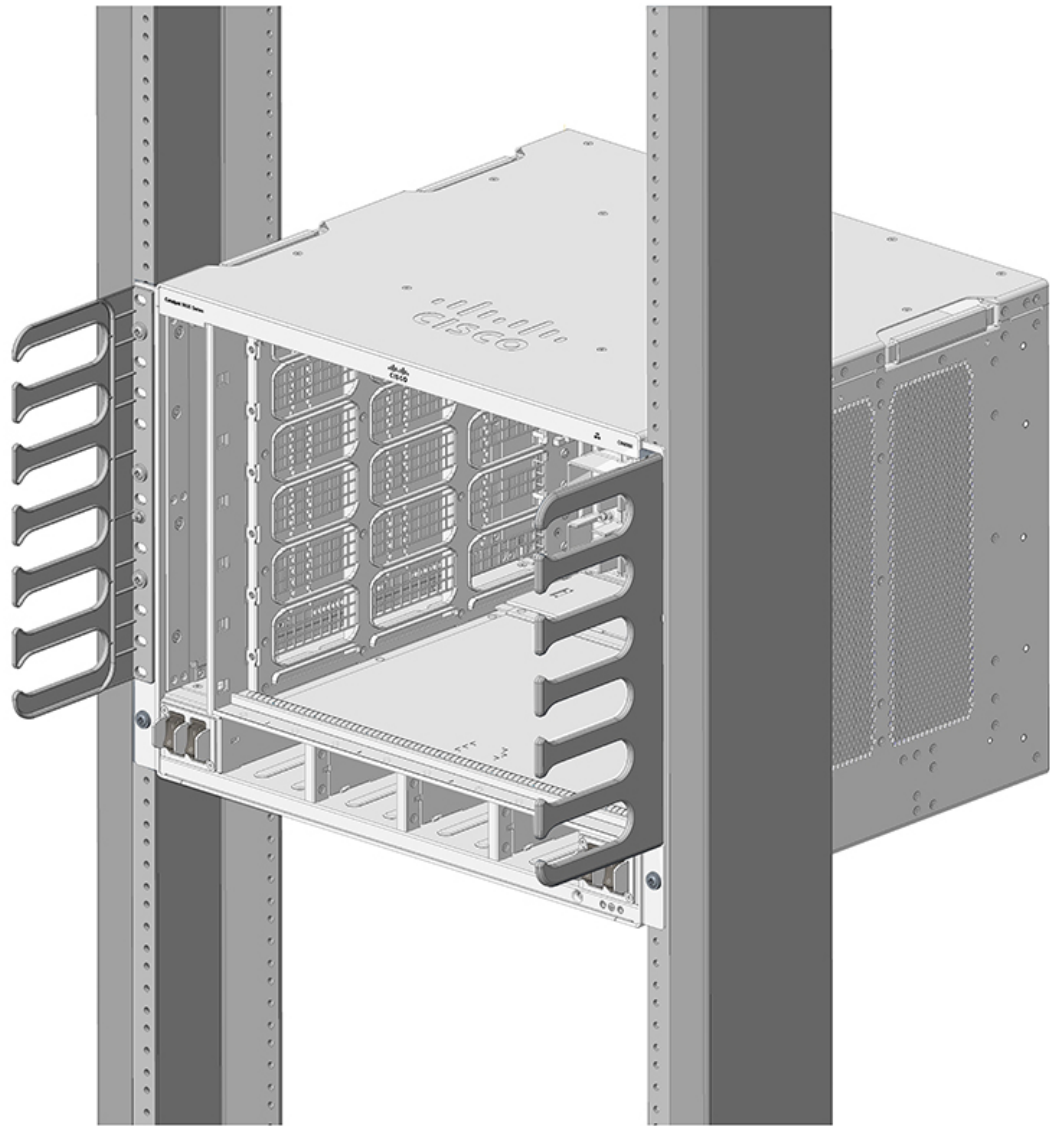


356048

1	Screws to attach the chassis to the rack post	2	Cable guide installed
---	-----------------------------------------------	---	-----------------------

Cable guide installation is complete.

Figure 9: Chassis with Cable Guide Attached



Rack-Mounting the Chassis as Shipped

This procedure shows how to rack mount the chassis as shipped.

Before you begin



Warning

To prevent bodily injury when mounting or servicing this unit in a rack, you must take special precautions to ensure that the system remains stable. The following guidelines are provided to ensure your safety:

- This unit should be mounted at the bottom of the rack if it is the only unit in the rack.
- When mounting this unit in a partially filled rack, load the rack from the bottom to the top with the heaviest component at the bottom of the rack.

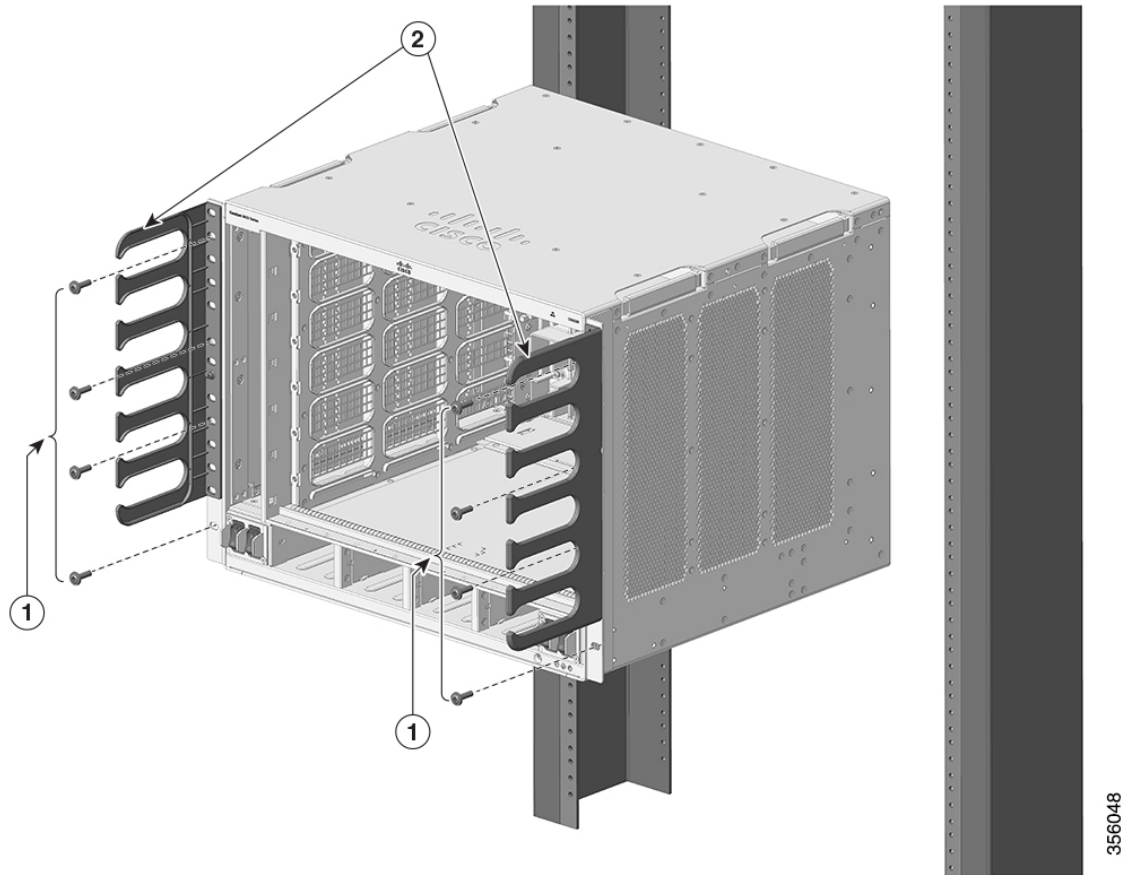
If the rack is provided with stabilizing devices, install the stabilizers before mounting or servicing the unit in the rack.

Statement 1006

Procedure

- Step 1** Insert the rear of the chassis between the mounting posts of the rack.
- Step 2** Align the mounting holes in the L bracket on the switch or on the cable mount (if installed) with the mounting holes in the equipment rack.

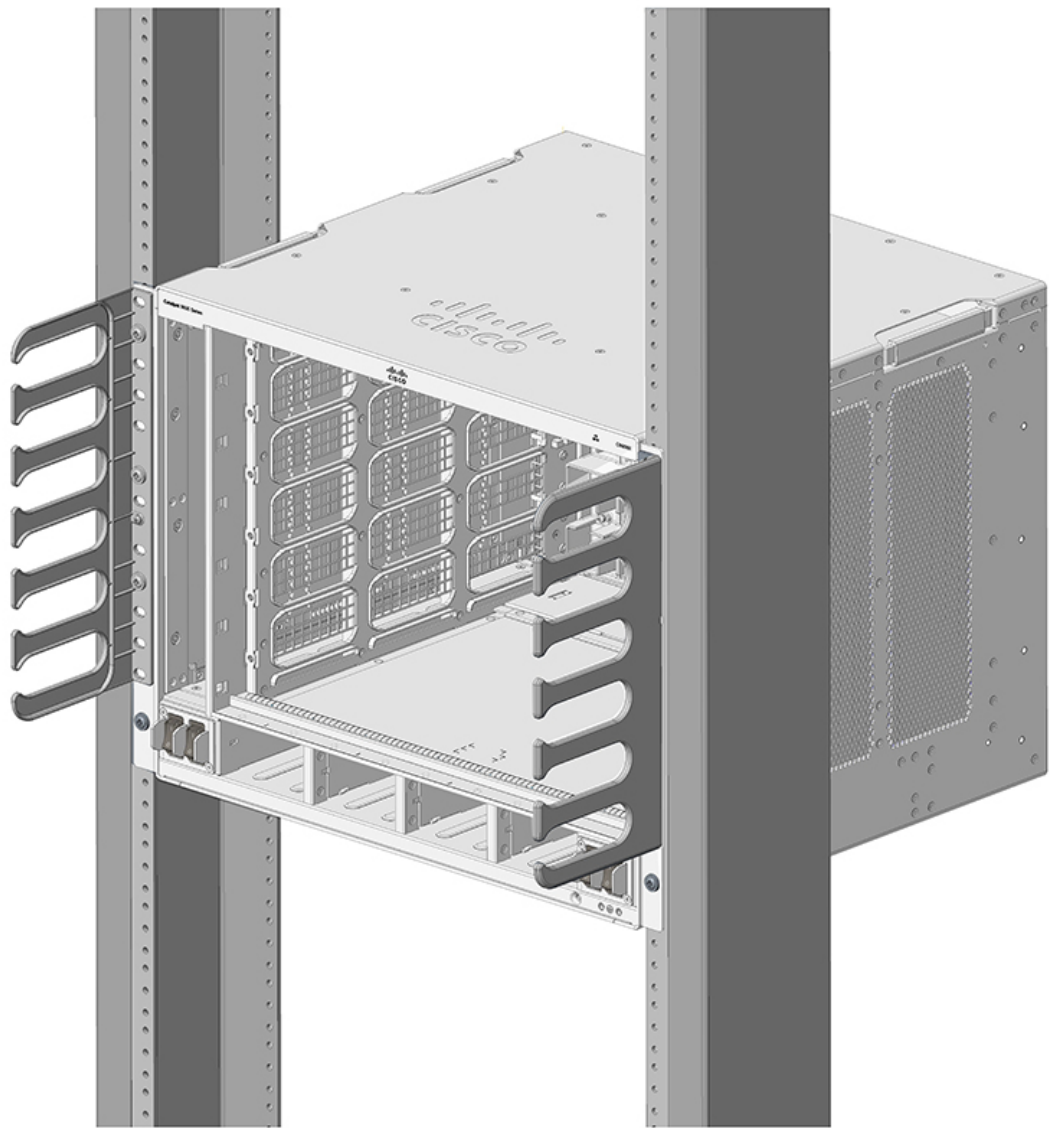
Figure 10: Securing the Chassis to the Rack Posts



1	10-32 or 12-24 pan head screws	2	Cable guides
---	--------------------------------	---	--------------

Step 3 Secure the chassis to the rack with either 10-32 or 12-24 pan head screws from the chassis standard accessory kit.

Figure 11: Chassis Secured to the Rack Posts



356049

- Step 4** 4. Use a tape measure and level to ensure that the chassis is installed straight and level..

What to do next

After installing the chassis in its location, complete the installation process by:

1. Connecting the chassis to system ground.
2. Installing and connecting the power supplies to the power source.
3. Connecting the network interface cables to the supervisor module and line card modules. This may involve installing transceivers before you attach the network interface cables.

4. Powering up the chassis and verifying the installation.

Install the Switch with Shelf Brackets

Installing the Shelf Kit L-Brackets

The switch chassis is shipped with two L-brackets installed on the front sides of the chassis. If you are rack-mounting the switch using the shelf kit, these L-brackets must be removed and replaced with L-brackets that are part of the shelf kit.

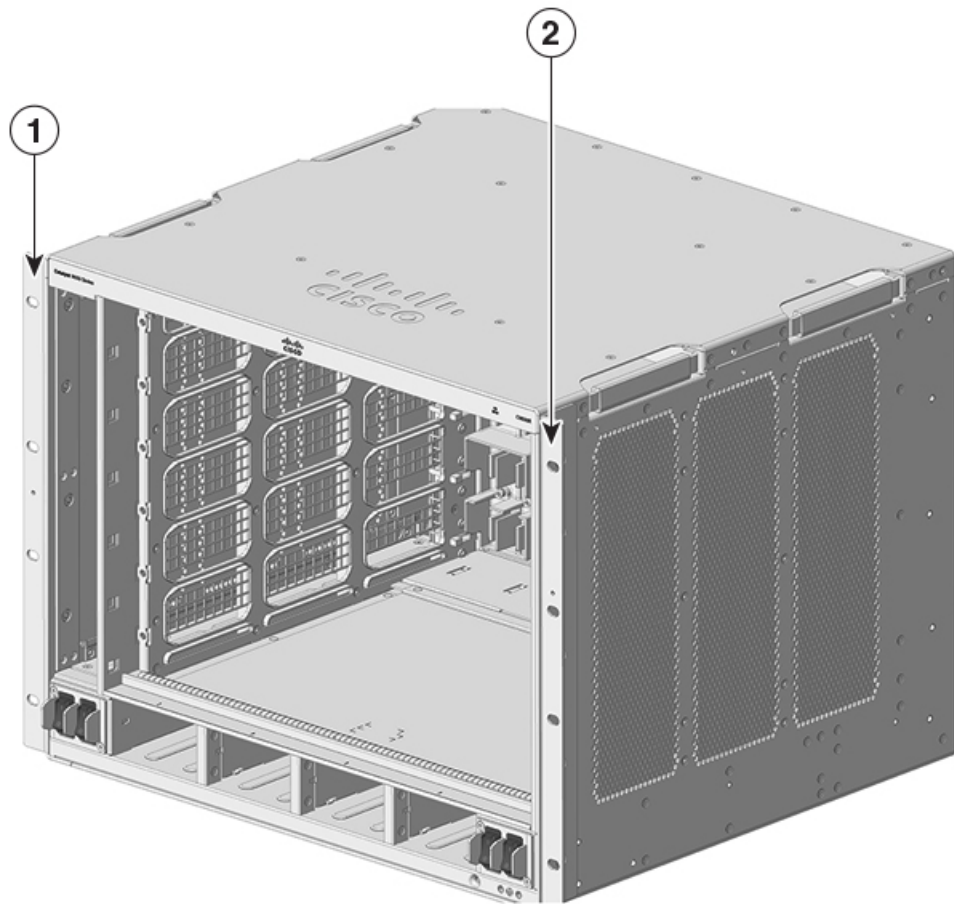
Before you begin

You have ordered and received the shelf kit.

Procedure

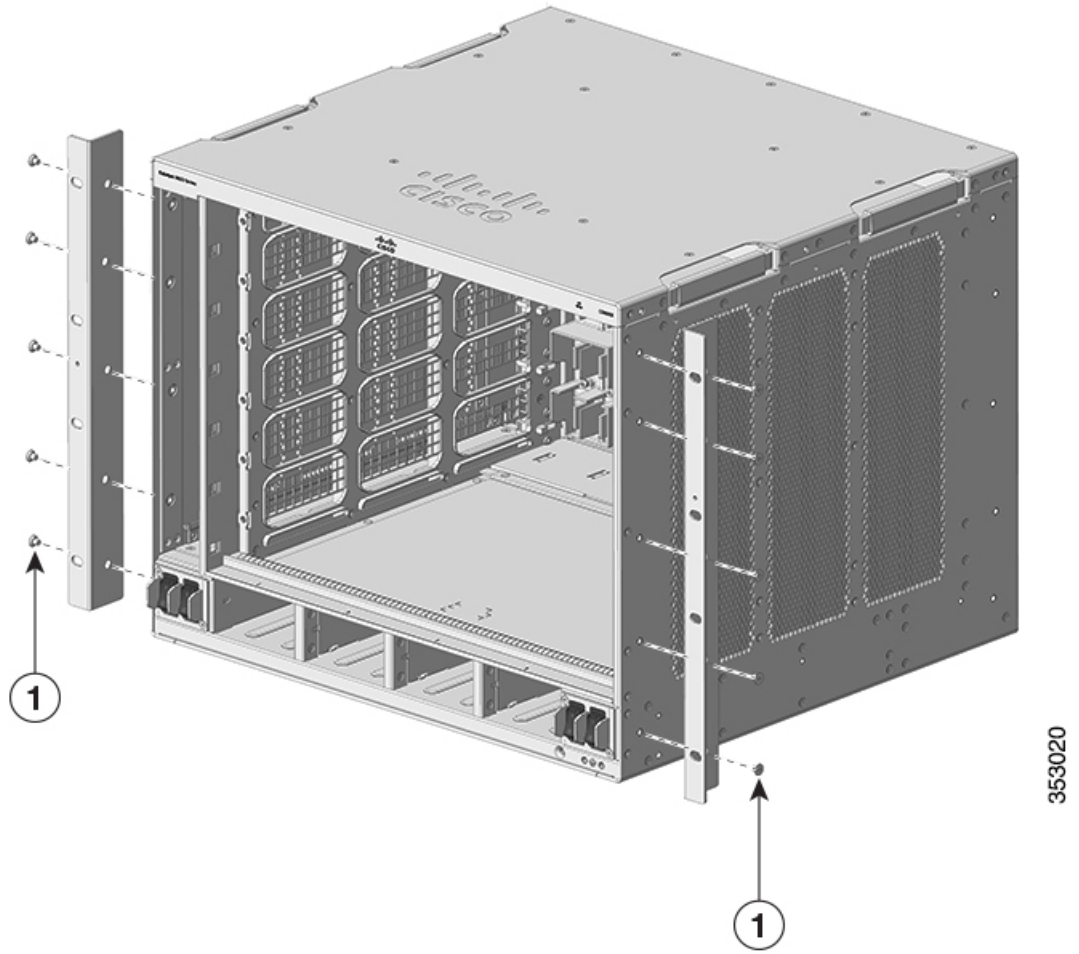
- Step 1** Remove and discard the L-brackets and the ten mounting screws that the chassis is shipped with. Do not re-use them during any part of the installation process.

Figure 12: L-Brackets the Chassis is Shipped with



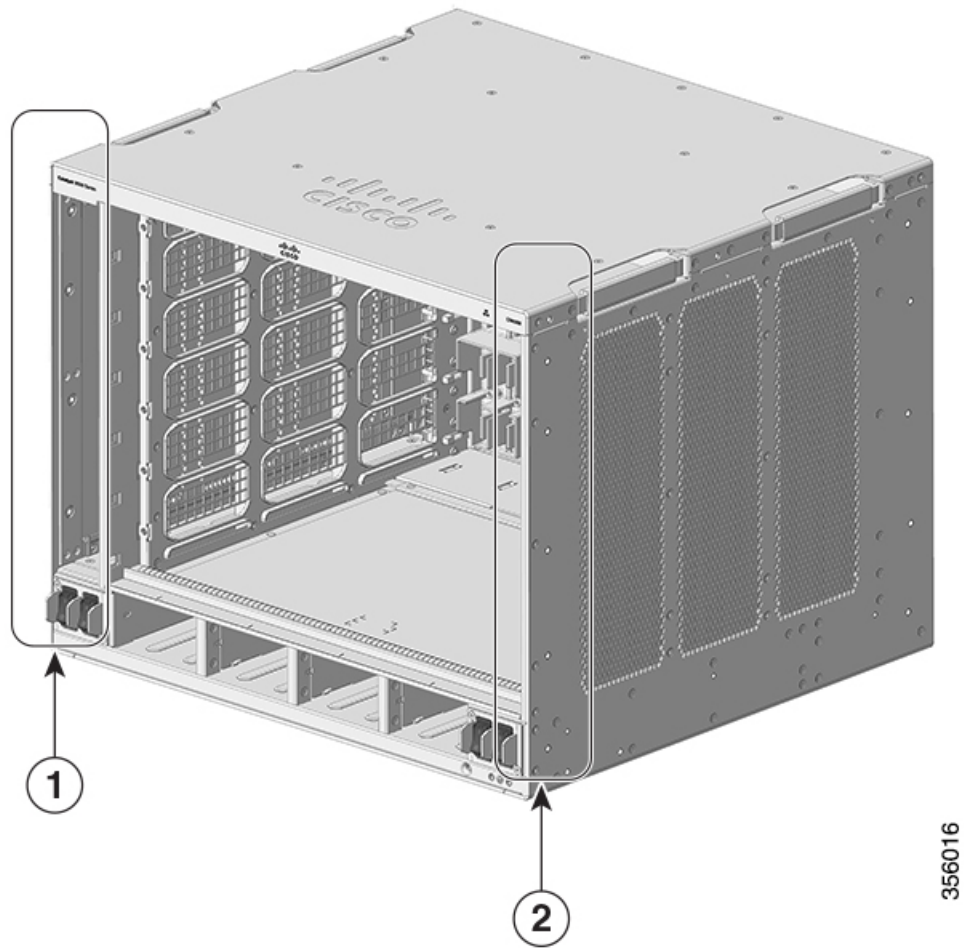
1	Left L-bracket	2	Right L-bracket
---	----------------	---	-----------------

Figure 13: Removing L-Brackets the Chassis is Shipped With



1	Mounting screws the chassis is shipped with	-	-
---	---------------------------------------------	---	---

Figure 14: Chassis Without L-Brackets

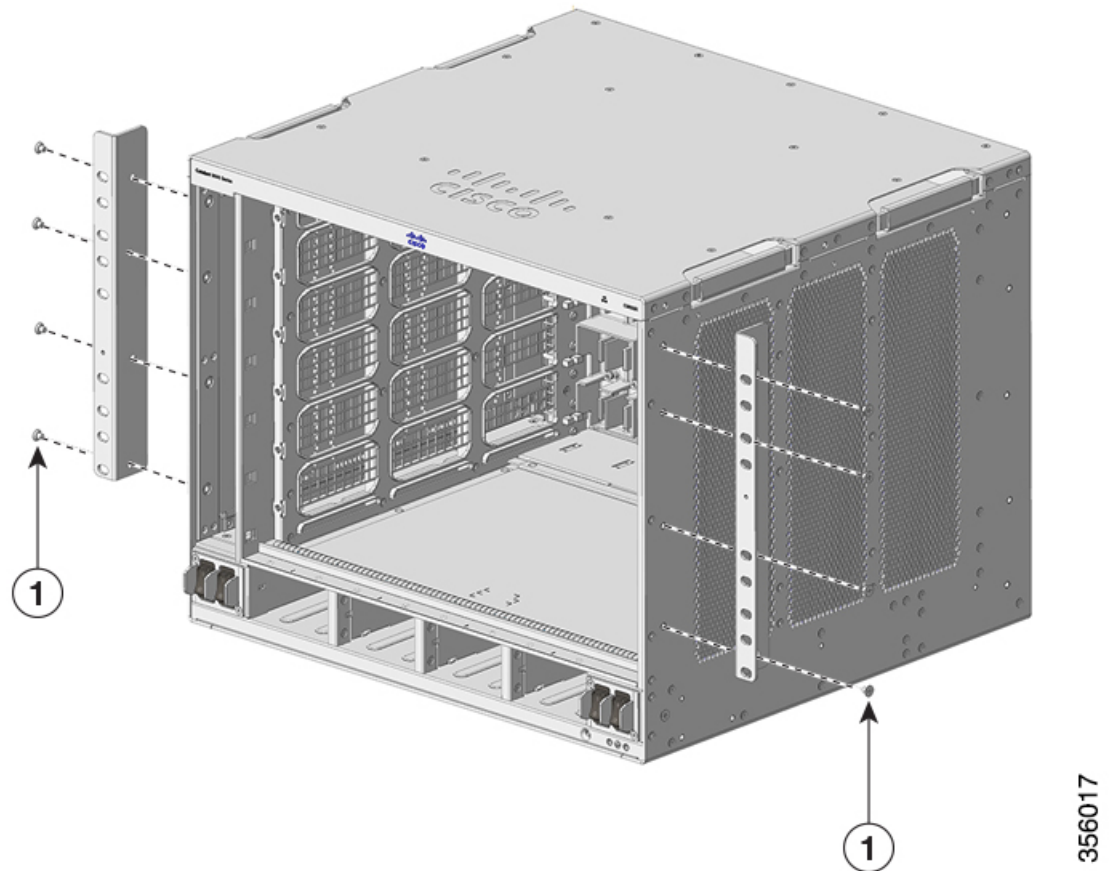


1	Chassis without left L-bracket	2	Chassis without right L-bracket
---	--------------------------------	---	---------------------------------

Step 2 Unpack the L-brackets from the shelf kit.

Step 3 Using the M4 x 8 mm Phillips flat head screws in the shelf kit, secure the L-brackets to the front-left and front-right sides of the chassis (four on each side).

Figure 15: Installing Shelf Kit L-Brackets



1	M4 x 8 mm Phillips flat head screws	-	-
---	-------------------------------------	---	---

What to do next

Install the shelf brackets on the rack.

Installing the Shelf Brackets and the Crossbar

Install the shelf brackets and the crossbar before you install the chassis in the rack to help support the weight of the chassis while you secure the L-brackets to the rack enclosure.

You have to front-mount the shelf brackets.

Before you begin

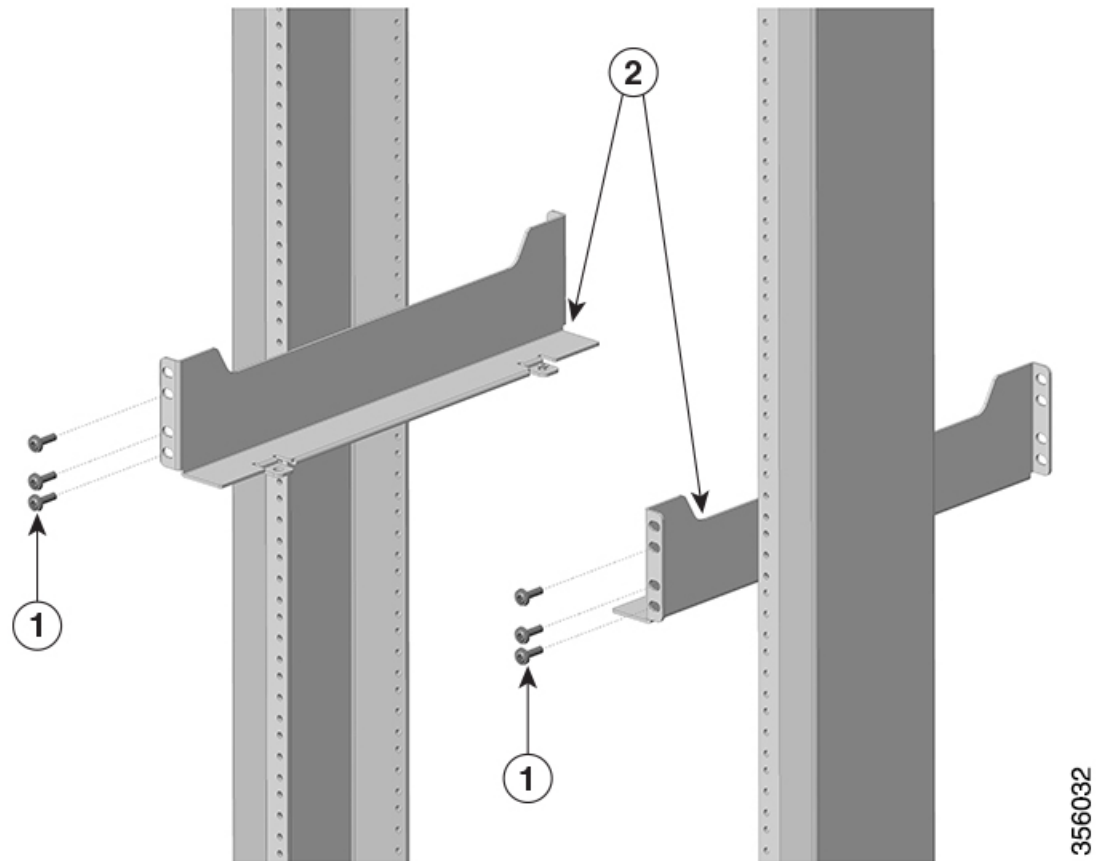
Determine the clearance between the insides of the left and right rails of your rack system and install the shelf brackets accordingly. Keep these tools handy:

- Number 1 and Number 2 Phillips screwdrivers
- 3/16-inch flat-blade screwdriver
- Tape measure and level

Procedure

- Step 1** Position the support flange of the left shelf bracket on the front of the left rail. Align and secure the bracket to the rack by using three screws. Use either 10-32 or 12-24 pan head screws from the shelf kit.
- Step 2** Position the support flange of the right shelf bracket on the front of the right rail — make sure that it is level with the left shelf bracket. Align and secure the bracket to the rack by using three screws.
- Use the same type of screws for the left and right shelf bracket.

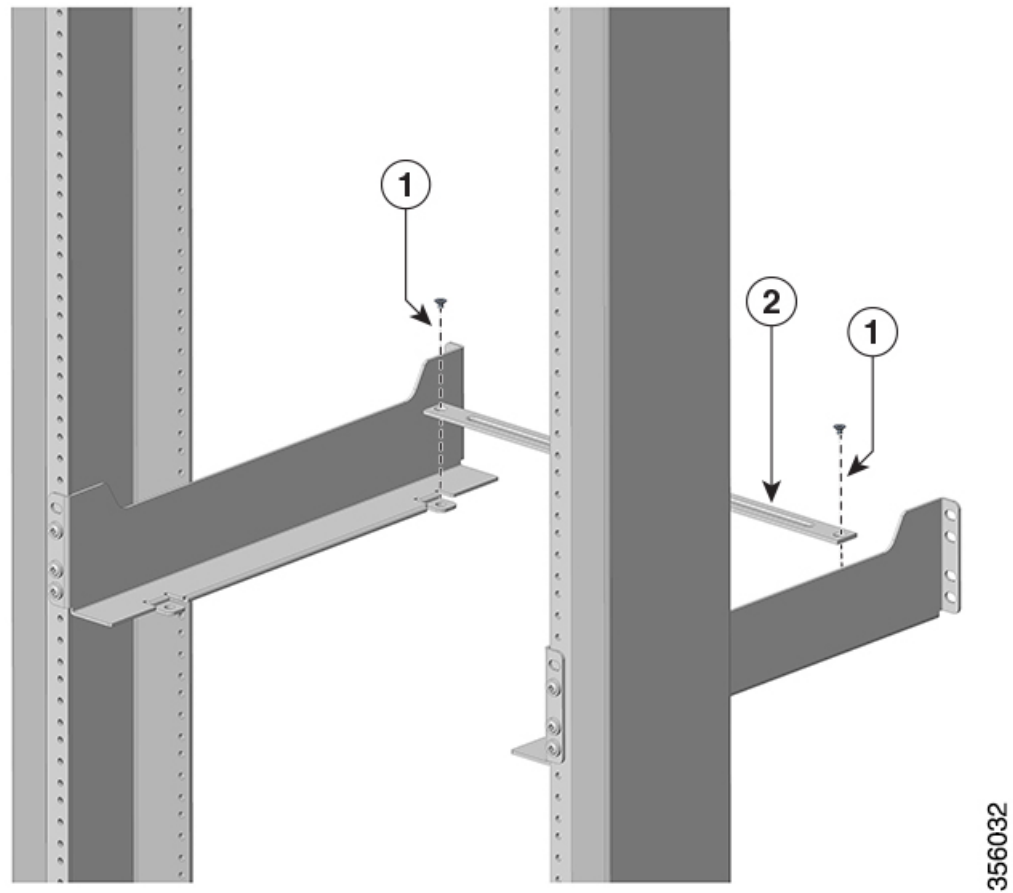
Figure 16: Installing the Shelf Brackets



1	Pan head screws from the shelf kit to secure the shelf brackets to the rack posts	2	Shelf brackets
---	-----------------------------------------------------------------------------------	---	----------------

Step 3 Secure the crossbar to the shelf brackets by using two M4 screws, with one screw on each side.

Figure 17: Securing the crossbar to the shelf brackets



356032

1	M4 x 5 mm flat-head screw	2	Crossbar
---	---------------------------	---	----------

The shelf brackets and the crossbar are now securely mounted to the rack posts.

What to do next

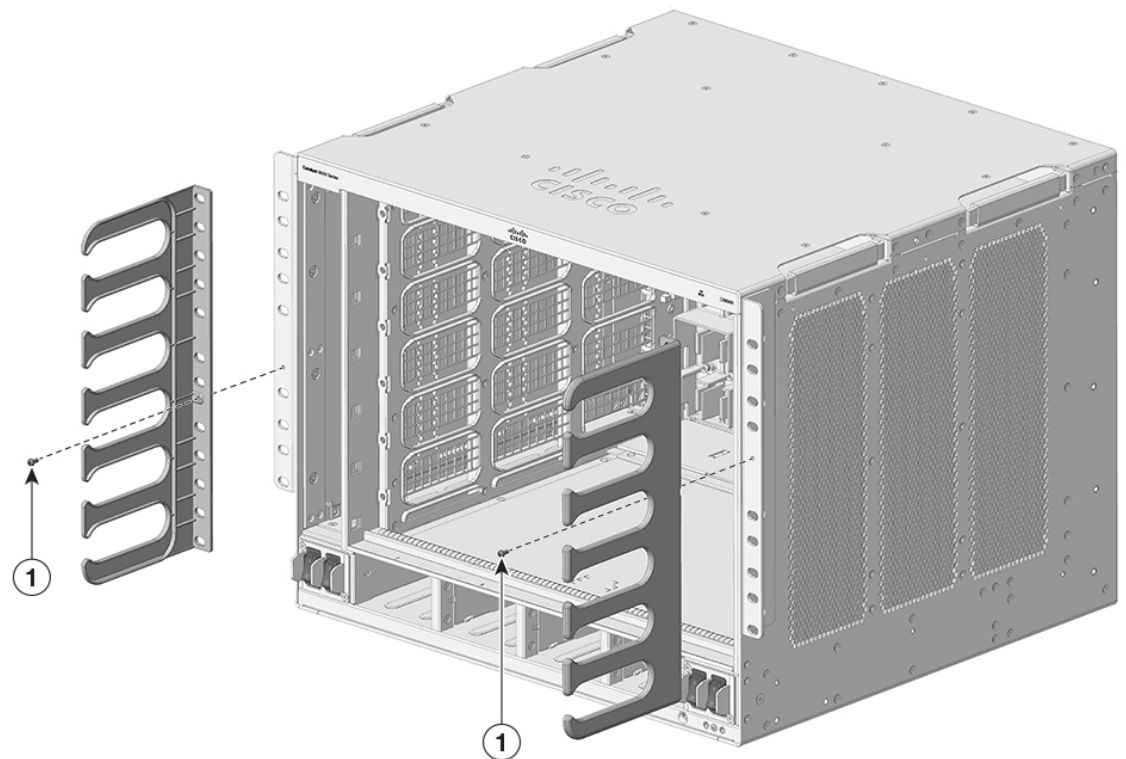
Install the cable guide to the chassis. Two people will be required for this task.

Installing the Cable Guide on the Chassis with Shelf Kit L-Bracket

Procedure

Step 1 Position the cable guides and align with the shelf kit L-brackets installed on the chassis.

Figure 18: Installing the Cable Guide



1	Screws to mount the cable guide
---	---------------------------------

Step 2 Secure the cable guides to the L brackets using the screws (one on each side) provided.

What to do next

Rack mount the chassis to a rack installed with shelf brackets and a crossbar.

Rack-Mounting the Chassis

This procedure shows how to rack mount the chassis with shelf brackets.



Warning

Two people are required to lift the chassis. To prevent injury, keep your back straight and lift with your legs, not your back. **Statement 164**



Tip

We recommend that you have a third person to assist in this procedure.

**Warning**

To prevent bodily injury when mounting or servicing this unit in a rack, you must take special precautions to ensure that the system remains stable. The following guidelines are provided to ensure your safety:

- This unit should be mounted at the bottom of the rack if it is the only unit in the rack.
- When mounting this unit in a partially filled rack, load the rack from the bottom to the top with the heaviest component at the bottom of the rack.

If the rack is provided with stabilizing devices, install the stabilizers before mounting or servicing the unit in the rack.

Statement 1006

To install the switch chassis in the equipment rack, perform these steps:

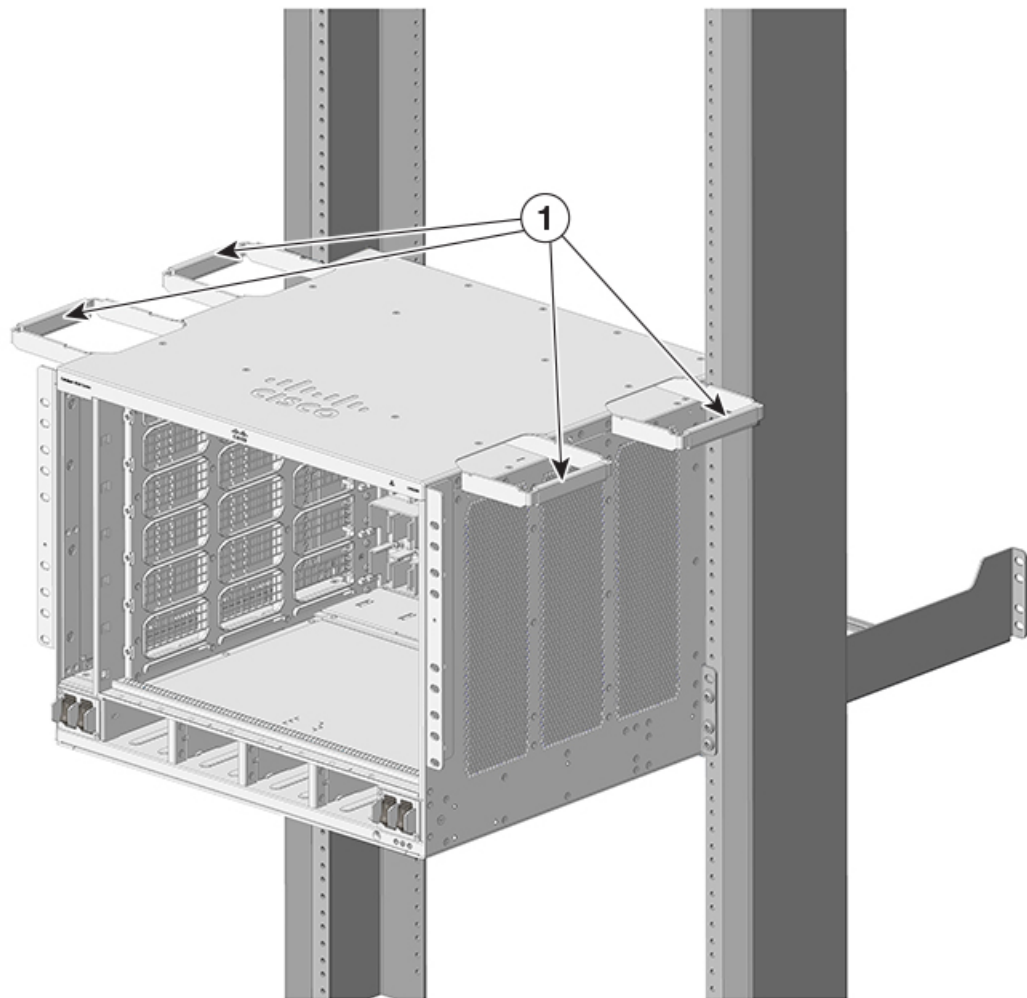
Before you begin

- Install the shelf kit L brackets on the chassis and the shelf brackets and crossbar on the rack posts.
- Install the cable guide.

Procedure

-
- Step 1** Pull out all four of the handholds on the chassis.

Figure 19: Chassis handholds

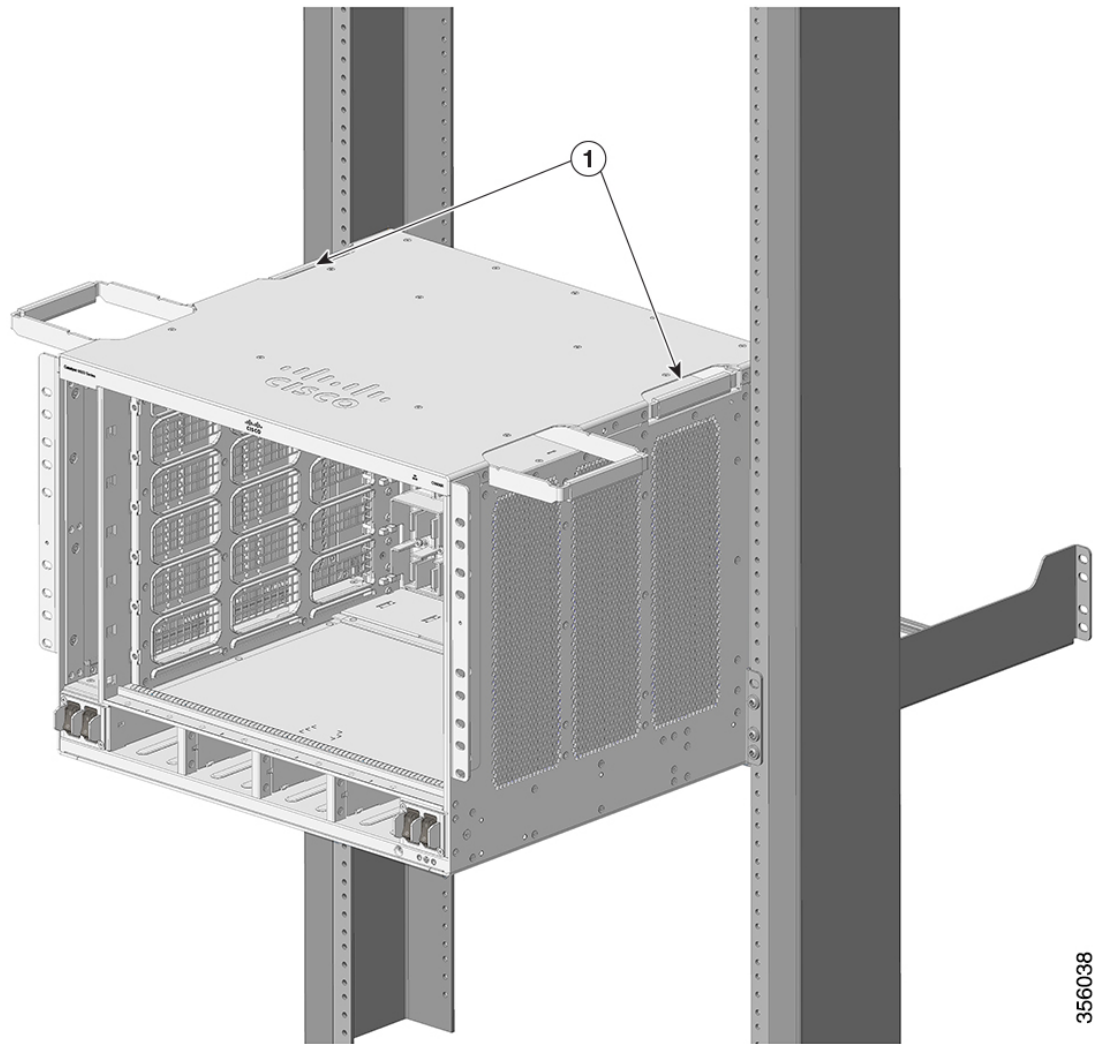


355034

1	All four of the chassis handholds pulled out and the back end of the chassis resting on the edges of the shelf bracket rails.	-	-
---	-------------------------------------------------------------------------------------------------------------------------------	---	---

- Step 2** With a person standing at each side of the chassis, insert one hand into each handhold. Slowly lift the chassis. Avoid sudden twists or moves to prevent injury.
- Step 3** Rest the back end of the chassis on the edges of the shelf bracket rails and slide it in until the first pair of handles on both sides of the chassis are near the rack posts.
- Step 4** Push in the handholds that are closest to the rack posts.

Figure 20: Sliding the Chassis in - Part 1

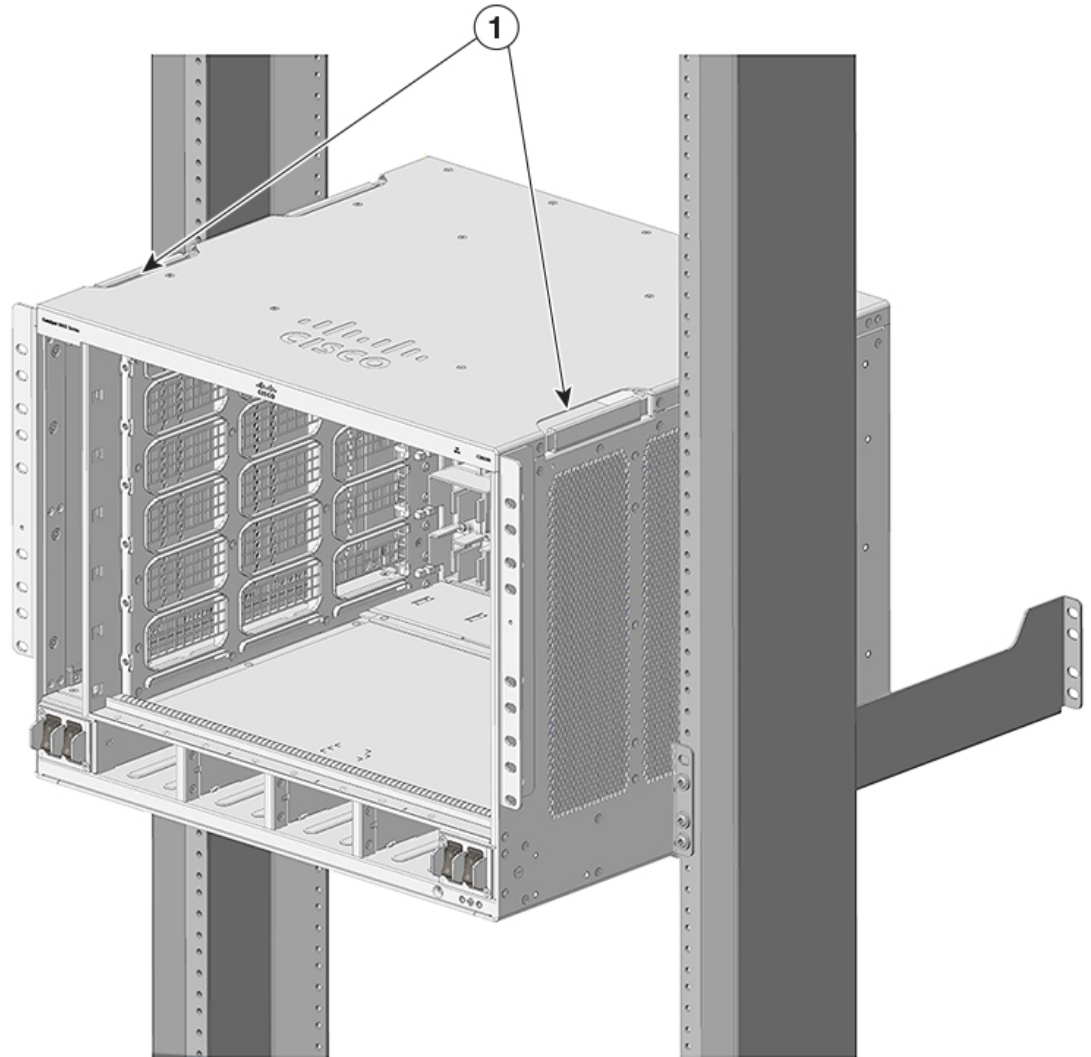


356038

1	Handholds closest to the rack posts, pushed in.	-	-
---	-------------------------------------------------	---	---

Step 5 Continue sliding the chassis in until the second pair of handholds are near the rack posts. Push in the second pair of handholds.

Figure 21: Sliding the Chassis in - Part 2



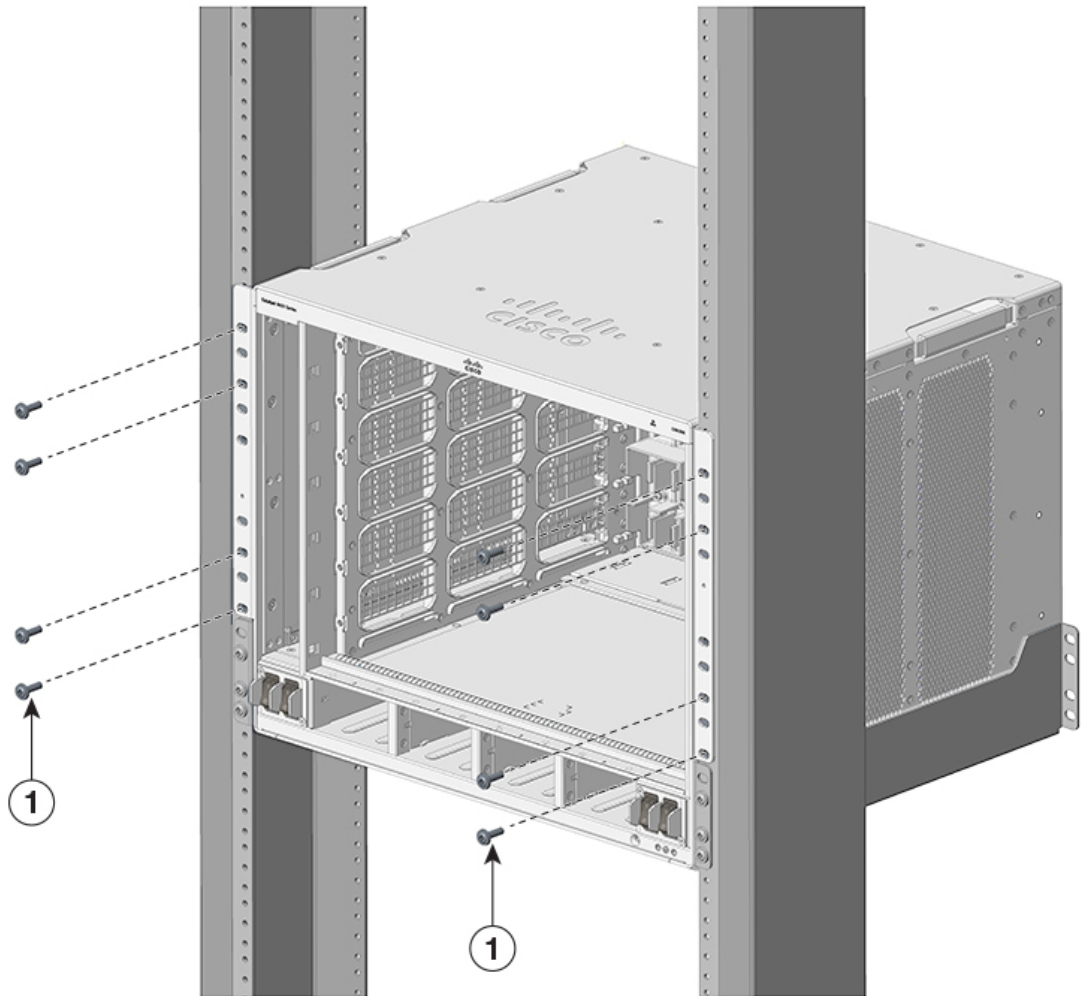
356040

1	Second pair of handholds, pushed in.
---	--------------------------------------

Step 6 Continue sliding the chassis rests completely on the shelf brackets and the crossbar. Slide in further until the L brackets make contact with the rack posts.

Step 7 Secure the chassis to the rack with either the 10-32 or 12-24 pan head screws from the chassis standard accessory kit.

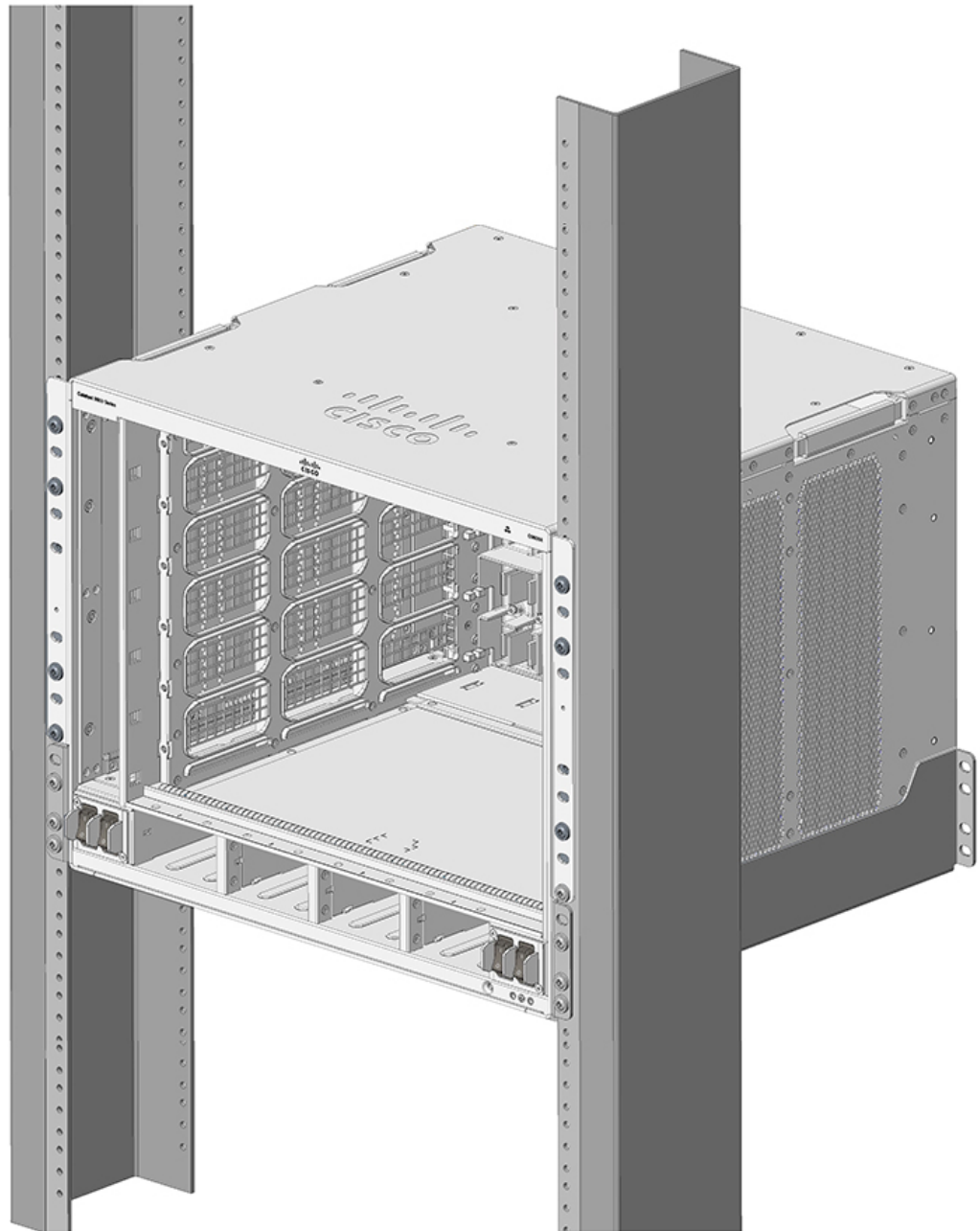
Figure 22: Securing the Chassis to the Rack Posts



356045

1	10-32 or 12-24pan head screws
---	-------------------------------

Figure 23: Chassis Secured to the Rack Posts



356047

What to do next

After installing the chassis in its location, complete the installation process by:

1. Connecting the chassis to system ground.
2. Installing and connecting the power supplies to the power source.

3. Connecting the network interface cables to the supervisor module and line card modules. This may involve installing transceivers before you attach the network interface cables.
4. Powering up the chassis and verifying the installation.

Install the Switch in NEBS-Compliant Mode

NEBS-Compliant Air Filter

A Network Equipment-Building System (NEBS) compliant installation allows filtered, front-to-rear airflow. To mount the chassis in a NEBS-compliant mode with the air filter, use a 23-inch rack mount. Filter brackets that are mounted on the side of the chassis hold the air filter.

A 23-inch rack mount is used for mounting the switch in a standard 23 inch (58.4 cm) equipment rack with two unobstructed outer posts. This kit is not suitable for racks with obstructions (such as a power strip) that could impair access to the field-replaceable units (FRUs) of the switch.

Rack-Mounting the Chassis in NEBS-Compliant Mode



Warning Take care when connecting units to the supply circuit so that wiring is not overloaded. **Statement 1018**



Warning To prevent the system from overheating, do not operate it in an area that exceeds the maximum recommended ambient temperature of 40°C. **Statement 1047**

Before you begin

- Read [Safety Warnings](#) carefully before starting with any installation procedure to make sure you understand the hazards and precautions.
- Place the chassis on the floor or on a sturdy table as close as possible to the rack. Leave enough clearance to allow you to move around the chassis.
- Open the rack-mount kit and verify that all parts are included.

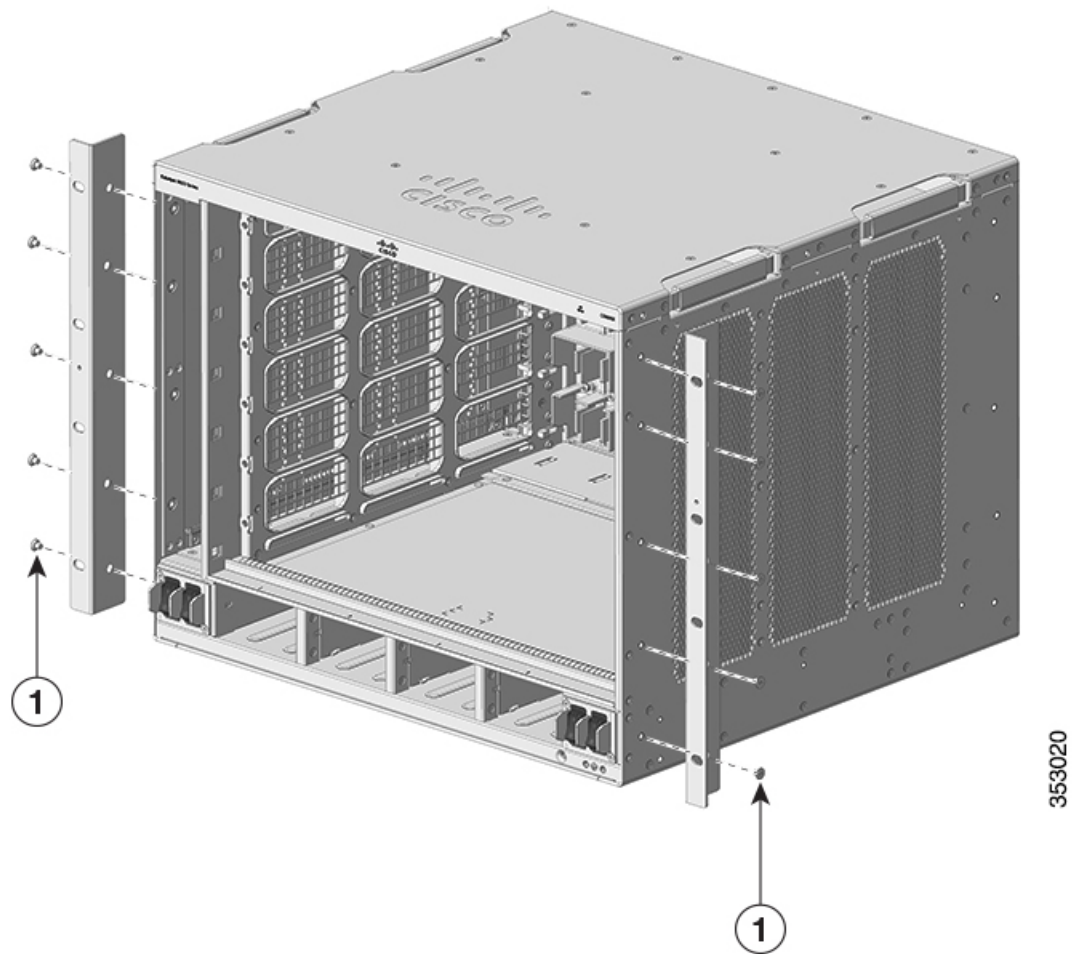


Note Some equipment racks provide a power strip along the length of one of the rear posts. If your rack has this feature, consider the position of the strip when planning fastener points. Before installing the brackets on the chassis, determine whether to install the chassis from the front or the rear of the rack.

Procedure

- Step 1** Remove and discard the mounting ears and the ten mounting screws of the chassis. Do not reuse them during any part of the installation process.

Figure 24: Remove the Mounting Ears

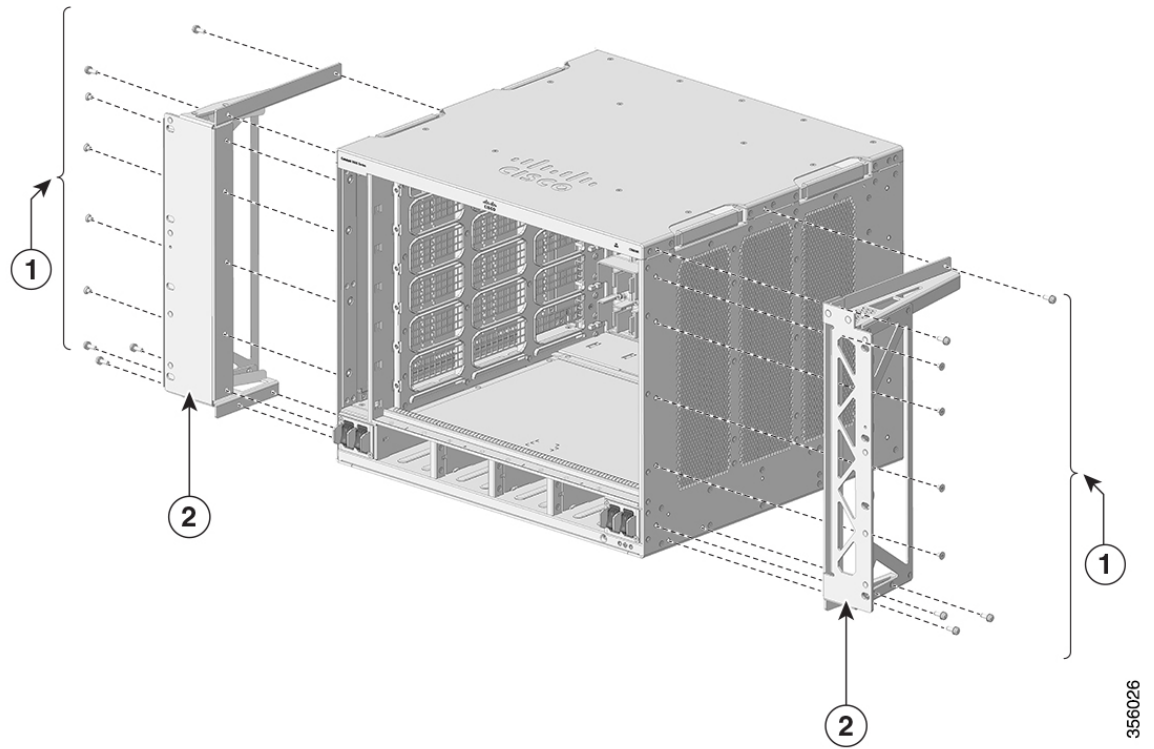


353020

1	Mounting screws
---	-----------------

- Step 2** Install the rack ear brackets on the left and right sides of the chassis. These brackets connect the chassis to the rack.

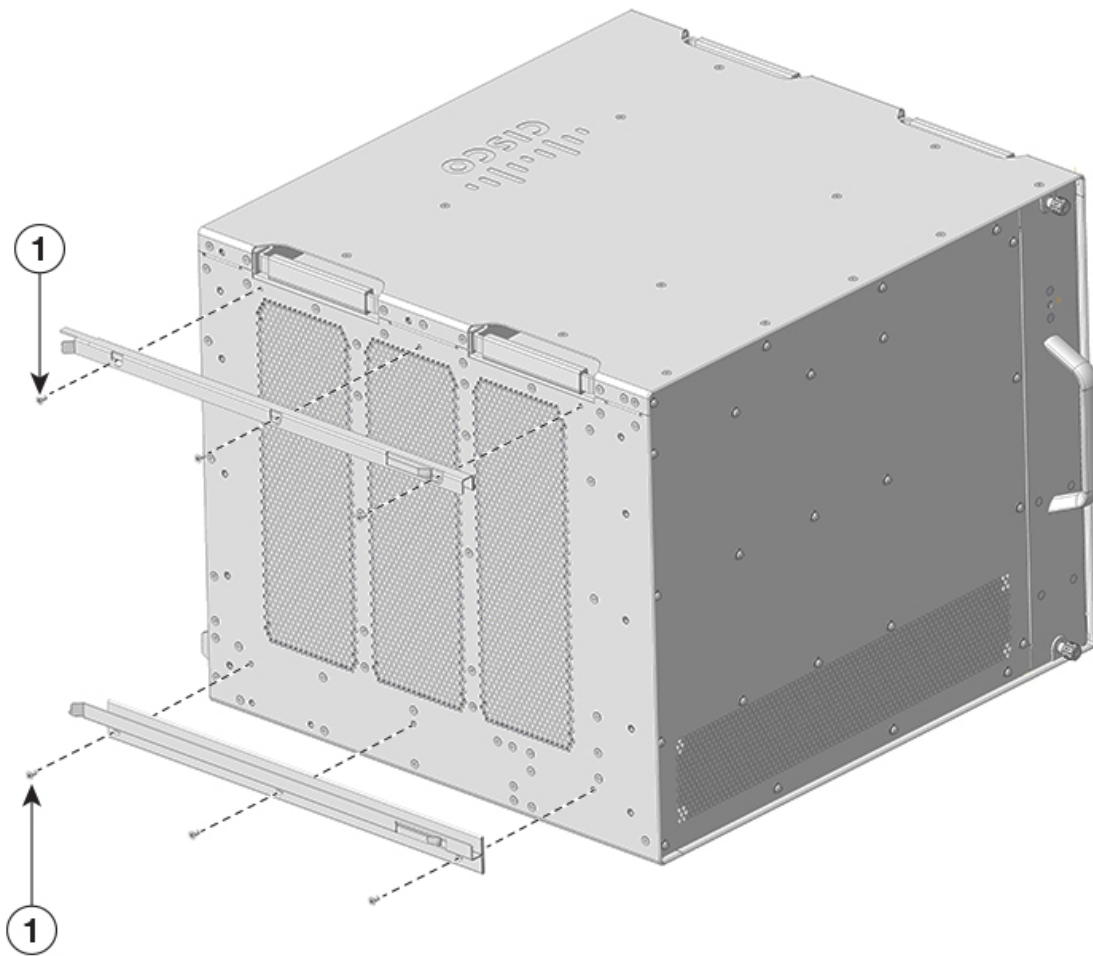
Figure 25: Install the Rack Ear Brackets



1	Screws to secure the rack ear brackets	2	Rack ear brackets
---	----------------------------------------	---	-------------------

Step 3 Install the filter brackets.

Figure 26: Install the Filter Brackets

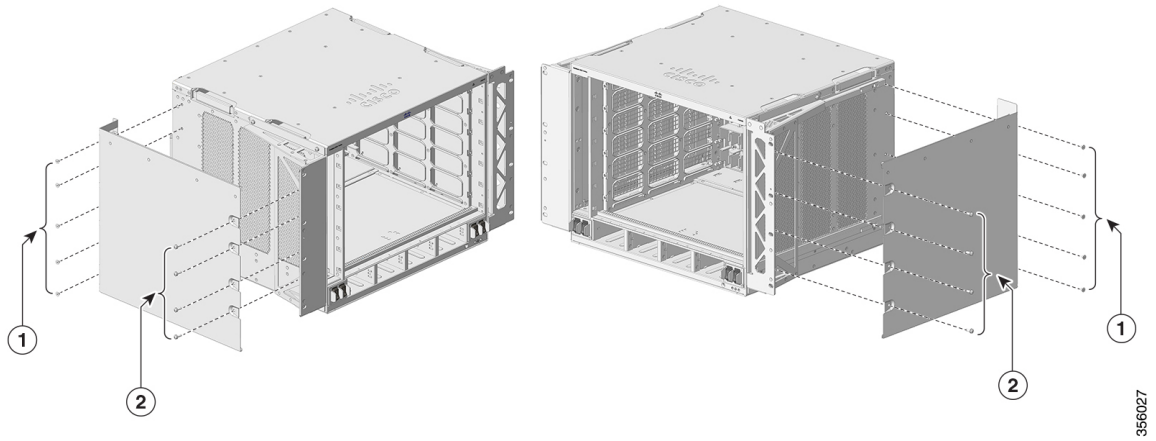


355025

1	M3x6mm flat head screws
---	-------------------------

Step 4 Install the right and the left wall covers.

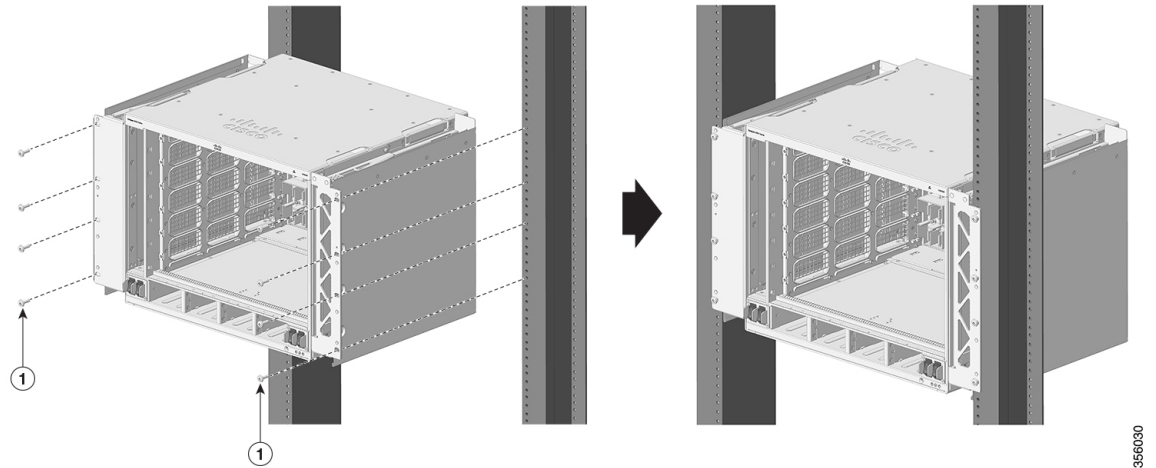
Figure 27: Install the Wall Covers



1	M4x5mm flat head screws	2	M4x12mm pan head screws
---	-------------------------	---	-------------------------

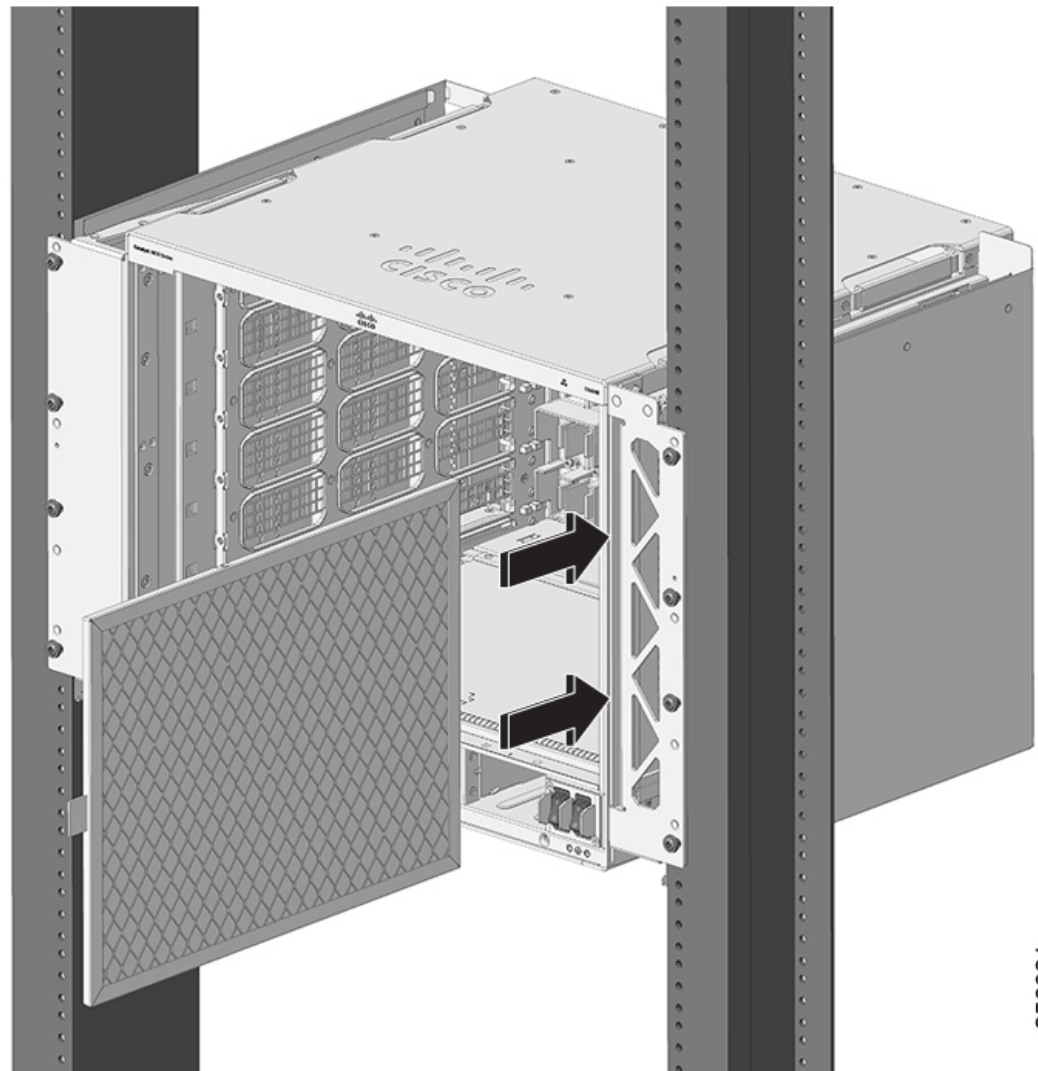
Step 5 Secure the chassis to the rack with either 10-32 or 12-24 pan head screws from the chassis standard accessory kit.

Figure 28: Secure the Chassis to Rack



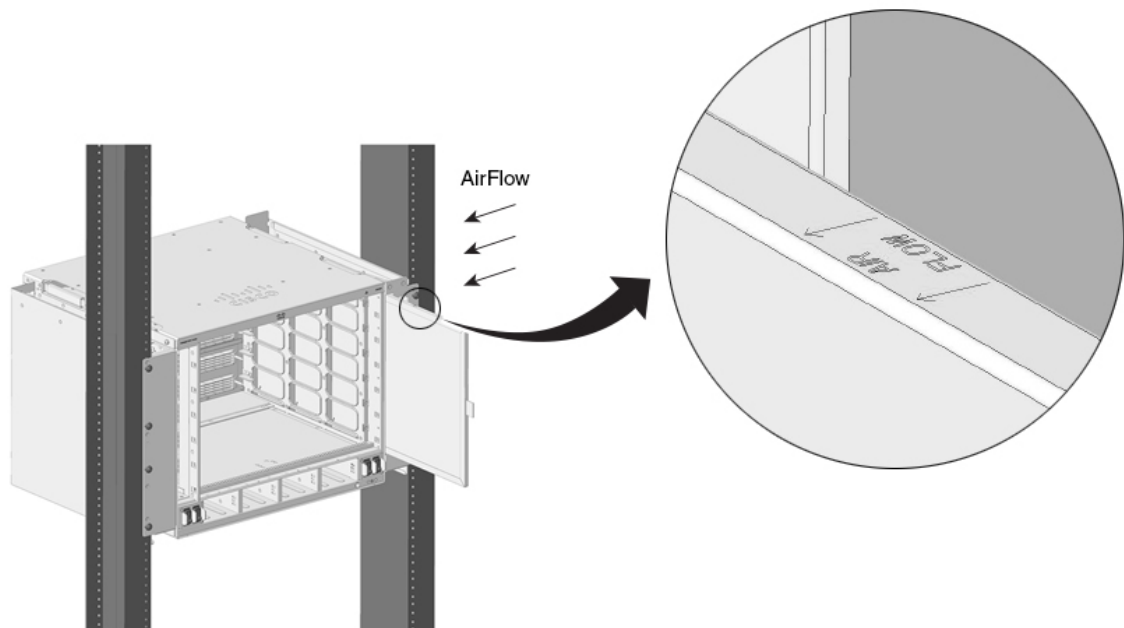
1	10-32 or 12-24 pan head screws
---	--------------------------------

Step 6 Align the air filter with the top and the bottom edges of the air filter slot.



- Step 7** Insert the air filter into its housing with the arrows pointing toward the chassis. The arrows on the top edge of the air filter note the direction of airflow. Airflow direction is from right to left, when you stand facing the chassis.

Figure 29: NEBS-Compliant Air Filter

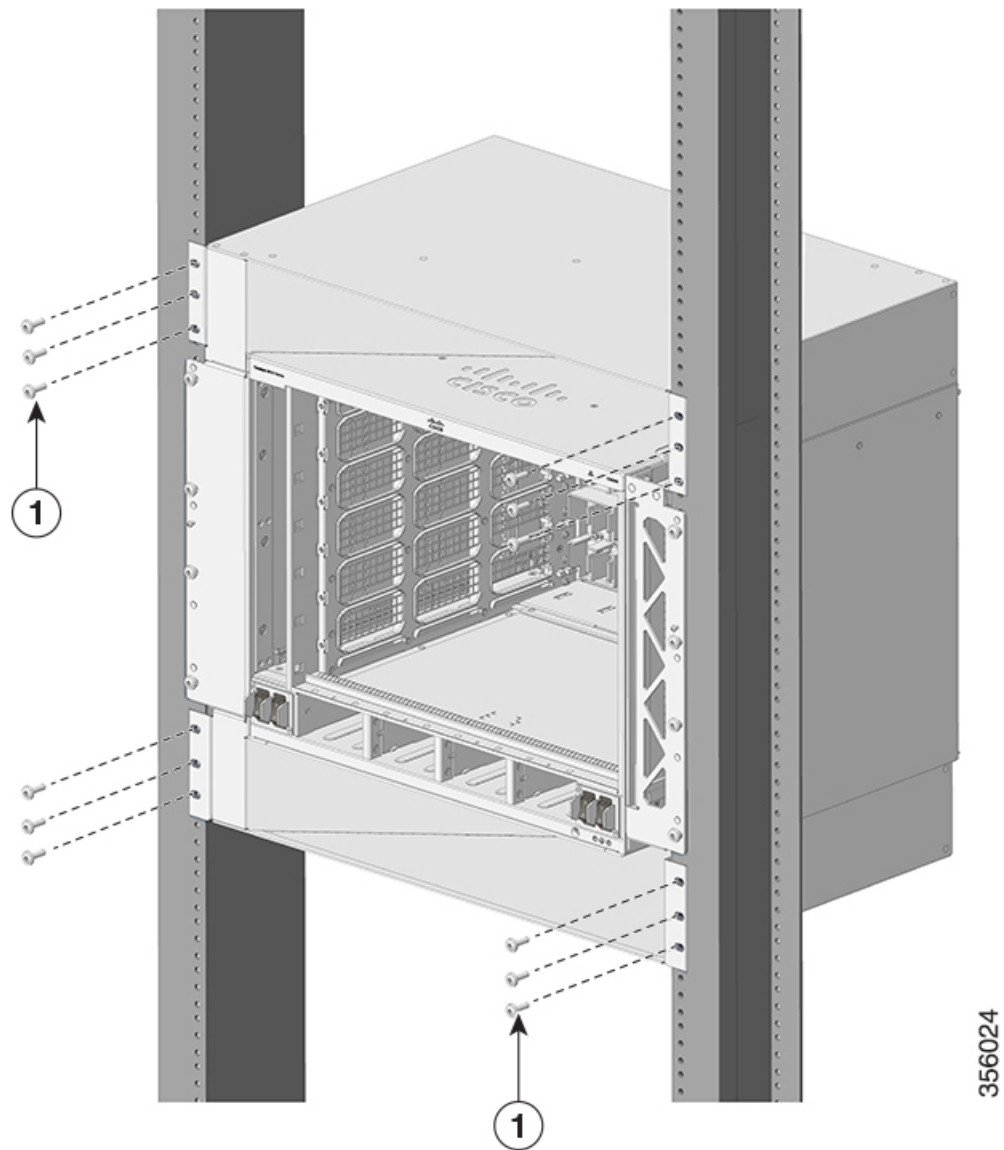


356028

Note We recommend that you change the air filter every 3 months. However, examine the air filter once a month (or more often in dusty environments) and replace it if it appears to be excessively dirty or damaged. To comply with Telecordia GR-63-Core standard air filter requirements for NEBS deployments, the air filter must be replaced, not cleaned.

Step 8 Install the top and base covers as shown in the illustrations:

Figure 30: Top Cover and Base Cover



356024

1	10-32 or 12-24 pan head screws
---	--------------------------------

Establishing System Ground

To attach the grounding lug and cable to the grounding pad, perform these steps:

Before you begin



Warning Before performing any of the following procedures, ensure that power is removed from the DC circuit. **Statement 1003**



Warning Use copper conductors only. **Statement 1025**



Warning When stranded wiring is required, use approved wiring terminations, such as closed-loop or spade-type with upturned lugs. These terminations should be the appropriate size for the wires and should clamp both the insulation and conductor. **Statement 1002**



Warning When installing or replacing the unit, the ground connection must always be made first and disconnected last. **Statement 1046**

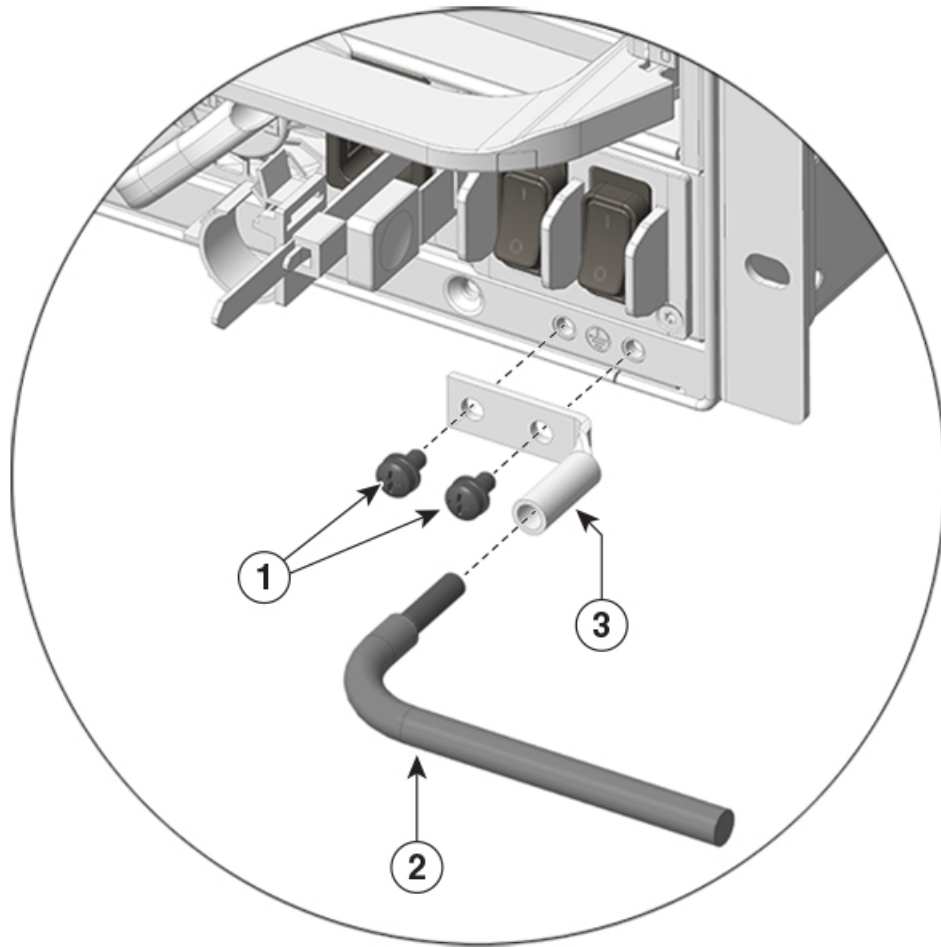
To connect the system ground, you require the following tools and materials:

- Grounding lug—A two-hole grounding lug, which supports up to 6 AWG size. Supplied as part of the standard accessory kit.
- Grounding screws—Two M4 x 8 mm (metric) pan-head screws. Supplied as part of the standard accessory kit.
- Grounding wire—The grounding wire should be sized according to local and national installation requirements. Depending on the power supply and system, a 12 to 6 AWG copper conductor is required for U.S. installations. Commercially available 6-AWG wire is recommended. The length of the grounding wire depends on the proximity of the switch to proper grounding facilities.
- No. 1 Phillips screwdriver.
- Crimping tool to crimp the grounding wire to the grounding lug.
- Wire-stripping tool to remove the insulation from the grounding wire.

Procedure

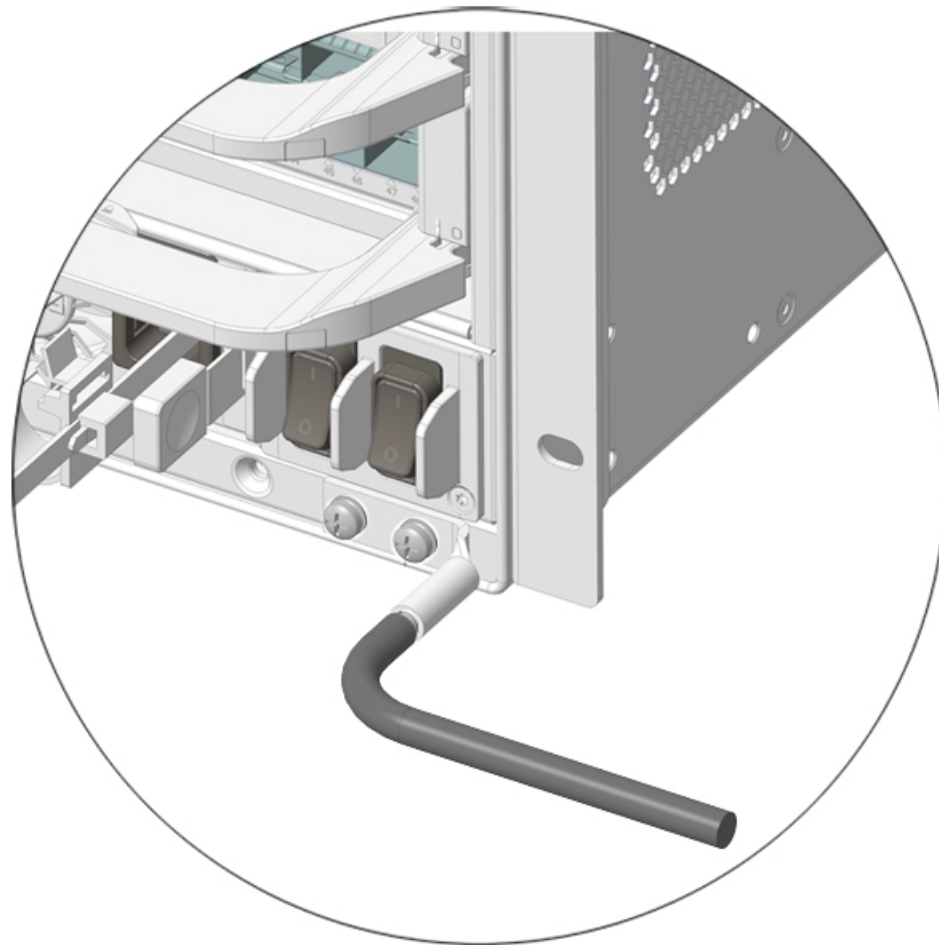
- Step 1** Use a wire-stripping tool to remove approximately 0.75 inches (19 mm) of the covering from the end of the grounding wire.
- Step 2** Insert the stripped end of the grounding wire into the open end of the grounding lug.
- Step 3** Crimp the grounding wire in the barrel of the grounding lug. Verify that the ground wire is securely attached to the ground lug.
- Step 4** Secure the grounding lug to the system ground connector with two M4 screws. Ensure that the grounding lug and the grounding wire do not interfere with other switch hardware or rack equipment.

Figure 31: Locating and Connecting System Ground



356050

1	M4 screws to secure the lug to the connector	3	Grounding lug
2	Stripped end of the grounding wire inserted into the open end of the grounding lug		

Figure 32: System Ground Connected

356051

- Step 5** Prepare the other end of the grounding wire, and connect it to an appropriate grounding point in your site to ensure adequate earth ground for the switch.
-

Attaching an ESD Strap

After you install the system ground lug, follow these steps to correctly attach the ESD wrist strap:

Procedure

- Step 1** Attach the ESD wrist strap to bare skin as follows:
- If you are using the ESD wrist strap supplied with the FRUs, open the wrist strap package and unwrap the ESD wrist strap. Place the black conductive loop over your wrist and tighten the strap such that it touches your bare skin well.

- b) If you are using an ESD wrist strap equipped with an alligator clip, open the package and remove the ESD wrist strap. Locate the end of the wrist strap that attaches to your body and secure it to your bare skin.

Step 2 Grasp the spring or alligator clip on the ESD wrist strap and momentarily touch the clip to a bare metal spot (unpainted surface) on the rack. We recommend that you touch the clip to an unpainted rack rail so that any built-up static charge is then safely dissipated to the entire rack.

Step 3 Attach either the spring clip or the alligator clip to the ground lug screw as follows:

- a) If you are using the ESD wrist strap that is supplied with the FRUs, squeeze the spring clip jaws open, position the spring clip to one side of the system ground lug screw head, and slide the spring clip over the lug screw head so that the spring clip jaws close behind the lug screw head.

Note The spring clip jaws do not open wide enough to fit directly over the head of the lug screw or the lug barrel.

- b) If you are using an ESD wrist strap that is equipped with an alligator clip, attach the alligator clip directly over the head of the system ground lug screw or to the system ground lug barrel.

When handling modules, follow these guidelines:

- Handle carriers using the available handles or edges only; avoid touching the printed circuit boards or connectors.
- Place a removed component boardside up on an antistatic surface or in a static shielding container. If you plan to return the component to the factory, immediately place it in a static shielding container.
- Never attempt to remove the printed circuit board from the metal carrier.

Caution For safety, periodically check the resistance value of the antistatic strap. The measurement should be between 1 and 10 megohm (Mohm).

Verifying the Switch Chassis Installation

To verify the switch chassis installation, perform these steps:

Procedure

Step 1 Verify that the ejector levers of each module are fully closed (parallel to the faceplate) to ensure that the supervisor engine and all the switching modules are fully seated in the backplane connectors.

Step 2 Verify that all empty module slots and power supply bays have blanks installed properly. The blanks optimize the air flow through the chassis and contain EMI.

Warning Blank faceplates and cover panels serve three important functions— They prevent exposure to hazardous voltages and currents inside the chassis; they contain EMI that might disrupt other equipment; and they direct the flow of cooling air through the chassis. Do not operate the system until all cards, face plates, front covers, and rear covers are in place. **Statement 1029**

Step 3 Turn on the power supply switches to power up the system. During the power-up sequence, the system performs a series of bootup diagnostic tests.

What to do next

Additional system diagnostic tests are available. These tests allow you to perform a complete sanity check on the system prior to inserting the system into your network and to monitor the health of the system while the system is running.



Tip When prestaging systems in a nonproduction environment, we recommend that you run all the diagnostic tests, including the disruptive tests, to prescreen the systems for failures, if any.



CHAPTER 4

Installing the Fan Tray

- [Guidelines for Removing and Installing a Fan Tray, on page 63](#)
- [Removing a Fan Tray, on page 63](#)
- [Installing a Fan Tray, on page 70](#)
- [Verifying Fan Tray Installation, on page 73](#)

Guidelines for Removing and Installing a Fan Tray

Before removing or installing a fan tray ensure you read and follow the guidelines and safety warnings listed here.



Warning

When removing the fan tray, keep your hands and fingers away from the spinning fan blades. Let the fan blades completely stop before you remove the fan tray. **Statement 258**



Warning

Only trained and qualified personnel should be allowed to install, replace, or service this equipment. **Statement 1030**



Warning

No user-serviceable parts inside. Do not open. **Statement 1073**



Warning

Installation of the equipment must comply with local and national electrical codes. **Statement 1074**

Removing a Fan Tray

The following sections explain the steps to remove a fan tray in a Cisco Catalyst 9600 Series switches.

Information About Replacing a Fan Tray

Online Insertion and Removal

While the fan tray is designed to be removed and installed while the system is operating (powered on) without presenting an electrical hazard or damage to the system, there is a time constraint when you remove and replace the fan tray in a system that is powered on.

**Caution**

The system can safely run without a fan tray only for a few minutes, until the critical temperature threshold is exceeded. Watch for any alarms triggered in software. After the critical temperature threshold is exceeded without sufficient cooling, the system shuts down if the alarm is not cleared.

When the fan tray is removed and replaced in a non-operating system, there is no time constraint.

Following the Correct Removal and Replacement Procedure

When you order a spare, only the fan tray is shipped. The connector is not shipped with a spare and you have to use the one originally available with the fan tray assembly.

You can remove and replace the fan tray from the front or the rear. When removed from the front of the chassis, only the fan tray is removed. When removed from the rear, the entire fan tray assembly (including the connector) is removed.

Removal and replacement from the front is suited to situations where access to the rear of the system is restricted. For instance, where the installation is in a closet. Removal and replacement from the rear is suited to situations where input and output cables are routed across the front panel, limiting access to the front panel of the fan tray.

Follow the corresponding removal and replacement procedures.

Enabling the Service Mode Before Removing the Fan Tray

This task describes how you can enable the service mode before removing the fan tray from the chassis. Enabling the service mode pushes the fans to operate at full speed and cool down the system sufficiently, allowing the system to sustain temperatures for the duration of servicing.

In a system that is operational, this applies to removal or replacement procedures from the front and the rear. You do not have to enable this mode if you are removing and replacing the fan tray in a system that is not powered on.

**Warning**

Only trained and qualified personnel should be allowed to install, replace, or service this equipment. **Statement 1030**

**Warning**

No user-serviceable parts inside. Do not open. **Statement 1073**

Starting in the privileged EXEC mode, enter the following command:

```
Device#test platform hardware chassis fantray service-mode on
fantray service mode on
```

The system automatically turns off the service mode after 10 minutes. This cools down the chassis sufficiently for the service duration.

To turn off the service mode before this system-allotted duration, enter the following command:

```
Device#test platform hardware chassis fantray service-mode off
fantray service mode off
```

Removing the Fan Tray from the Front of the Chassis

Before you begin

- Read [Guidelines for Removing and Installing a Fan Tray, on page 63](#).
- Enable the service mode on the chassis, if you are performing this task in a system that is powered on.
- Ensure that you have the following tools and accessories available:
 - Phillips-head screwdriver
 - Anti-static mat

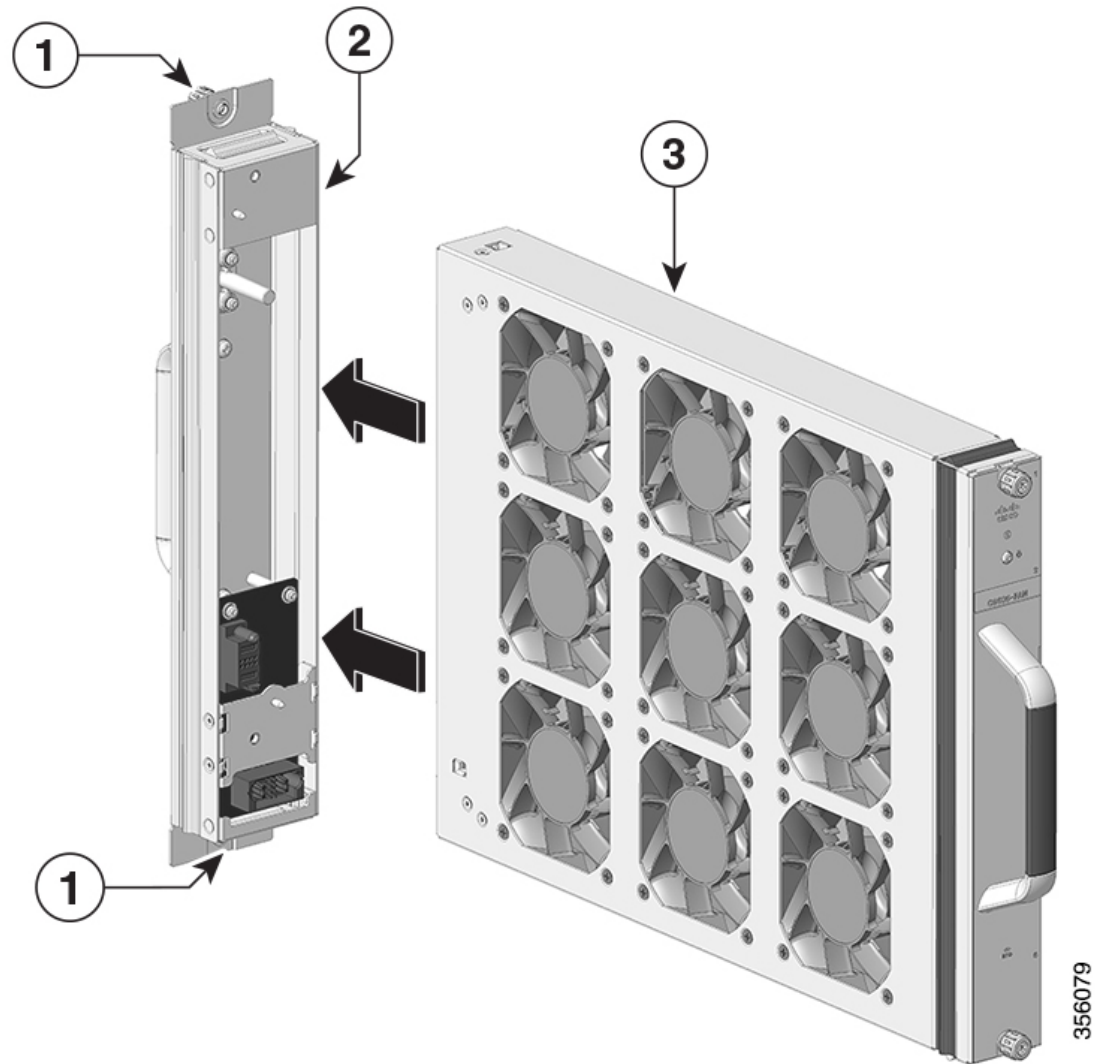
Procedure

Step 1 Keep the replacement fan tray ready for installation.

Important When you remove and replace the fan tray in a system that is powered on, there is a time constraint. The system can safely run without a fan tray only for 2 minutes. So it is important to complete this first step and its sub-steps before you remove the fan tray from the front of the chassis.

- a) Remove the replacement fan tray from the shipping packaging.
- b) Use the Phillips-head screwdriver and loosen the two captive installation screws on the front panel of the replacement fan tray (the side with the fan STATUS LED), to detach it from the connector.

Figure 33: Detaching the Connector from the Fan Tray



1	Captive installation screws on the front of the fan tray assembly	3	Fan tray
2	The connector in the rear, separated from the fan tray	-	-

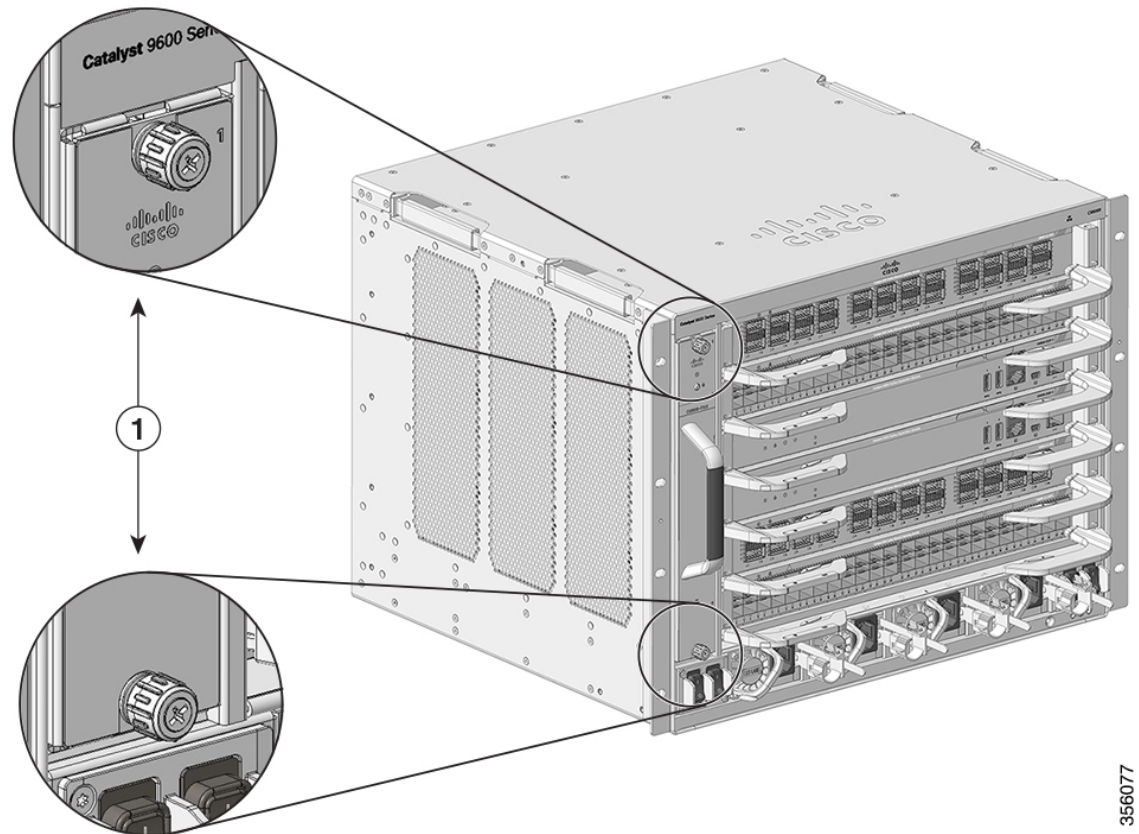
The connector is not used or replaced when installed from the front. The connector can be scrapped or stored for future use.

- c) Place the replacement fan tray on an anti-static mat and within arm's reach.

Step 2

Proceed with removing the fan tray from the chassis. Loosen the two captive installation screws on the front panel of the fan tray (the side with the fan STATUS LED).

Figure 34: Removing the Captive Installation Screws



356077

1	Captive installation screws on the front of the fan tray assembly in the chassis
---	----------------------------------------------------------------------------------

- Step 3** Grasp the fan tray handle and slide the fan tray half-way out of the bay. Gently move it from side to side, if necessary, to unseat it from the backplane.
- Step 4** Wait for the fan blades to stop spinning; place your other hand underneath to support the bottom of the fan tray and then remove the fan tray completely.
- Only the fan tray is removed from the chassis (excluding the connector).

What to do next

Set the removed fan tray aside and proceed with installing the replacement or spare fan tray.

Removing the Fan Tray from the Rear of the Chassis

When you remove the fan tray from the rear, the fan tray assembly is removed. This includes the fan tray and the connector.

Before you begin

- Read [Guidelines for Removing and Installing a Fan Tray](#), on page 63.
- Enable the service mode on the chassis, if you are performing this task in a system that is powered on.
- Ensure that you have the following tools and accessories available:
 - Phillips-head screwdriver
 - Anti-static mat

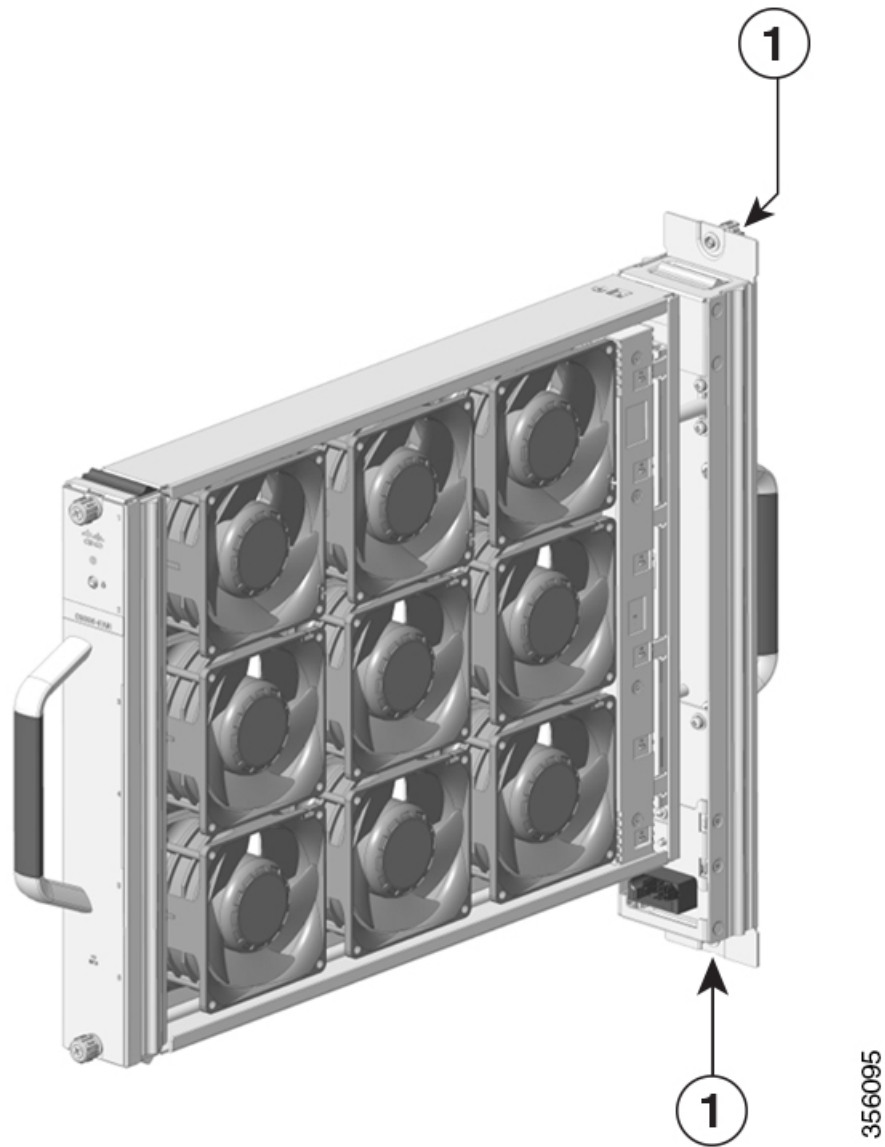
Procedure

Step 1

Keep the replacement fan tray ready by removing it from the shipping packaging. Place it on an anti-static mat and within arm's reach. Do not detach the connector module.

Important When you remove and replace the fan tray in a system that is powered on, there is a time constraint. The system can safely run without a fan tray only for 2 minutes. So it is important to complete this first step before you remove the fan tray from the rear of the chassis.

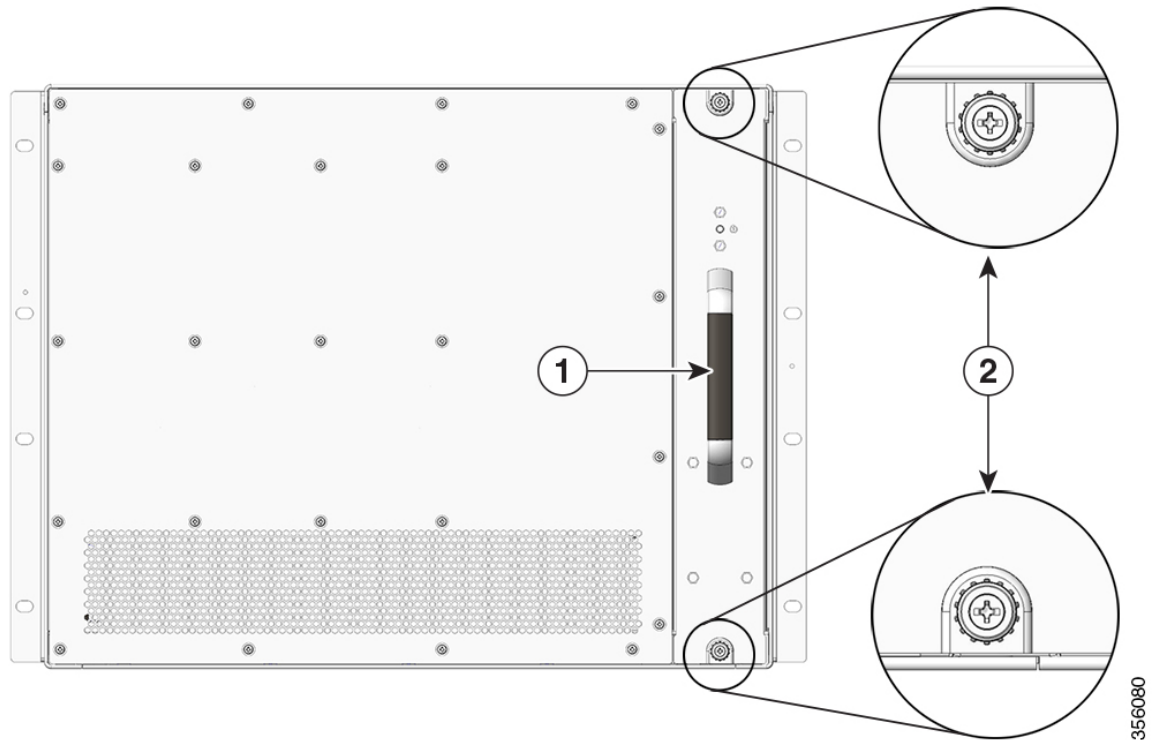
Figure 35: Fan Tray with the Connector



1	Fan tray with the connector
---	-----------------------------

Step 2 Proceed with removing the fan tray from the chassis. Loosen the two captive installation screws on the rear panel of the fan tray.

Figure 36: Captive Installation Screws on the Rear Panel



1	Rear fan tray handle	2	Captive installation screws on the rear panel. Note Loosen to uninstall the fan tray assembly from the rear.
---	----------------------	---	------------------------------------------------------------------------------------------------------------------------

Step 3 Grasp the fan tray handle and slide the fan tray assembly half-way out of the bay.

Step 4 Wait for the fan blades to stop spinning; place your other hand underneath to support the bottom of the fan tray and then remove the fan tray assembly completely.

What to do next

Set the removed fan tray aside and proceed with installing the replacement or spare fan tray.

Installing a Fan Tray

The following sections provide information about installing a fan tray in Cisco Catalyst 9600 Series switches.

Installing the Fan Tray from the Front Panel of the Chassis

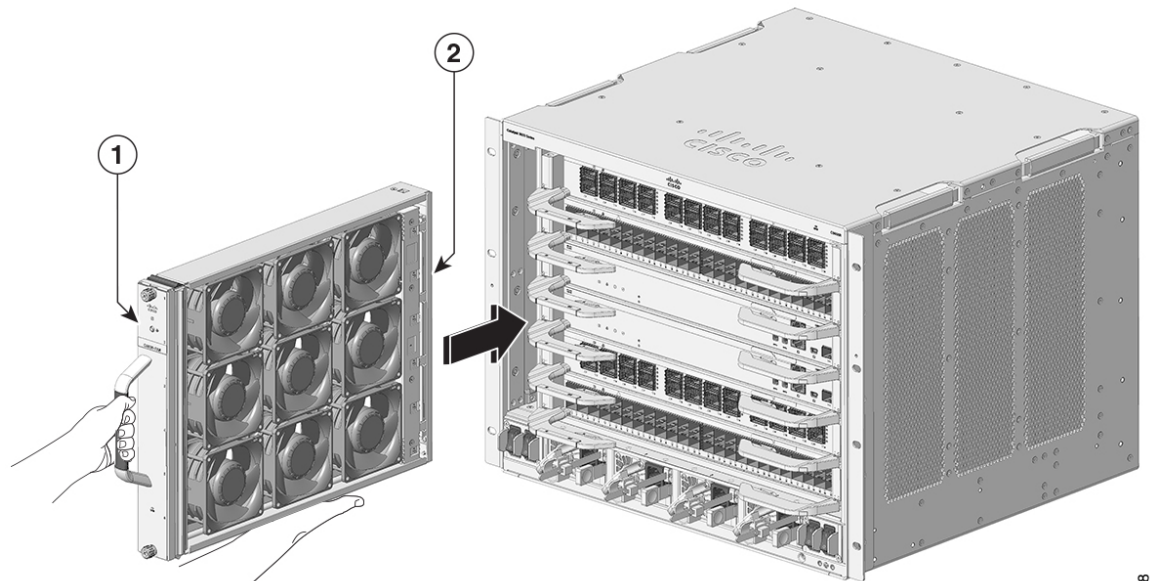
Before you begin

- Read [Guidelines for Removing and Installing a Fan Tray, on page 63](#).
- Enable the service mode on the chassis, if you are performing this task in a system that is powered on.
- Ensure that you have the following tools and accessories available:
 - Phillips-head screwdriver
 - Anti-static mat

Procedure

- Step 1** Hold the fan tray assembly with the fans facing to the right.
- Step 2** Place the fan tray into the fan tray slot so it rests on the chassis, and then lift the fan tray up slightly, aligning the top and bottom guides.

Figure 37: Inserting the Fan Tray from the Front of the Chassis



356078

1	Front side of the fan tray	2	Fan tray without the connector
---	----------------------------	---	--------------------------------

- Step 3** Slide the fan tray into the chassis until the two captive installation screws make contact with the chassis.
- Step 4** Tighten the two captive installation screws on the front, to secure the fan tray assembly in the chassis.

What to do next

Verify that you have installed the fan tray correctly. See [Verifying Fan Tray Installation, on page 73](#).

Installing the Fan Tray from the Rear of the Chassis

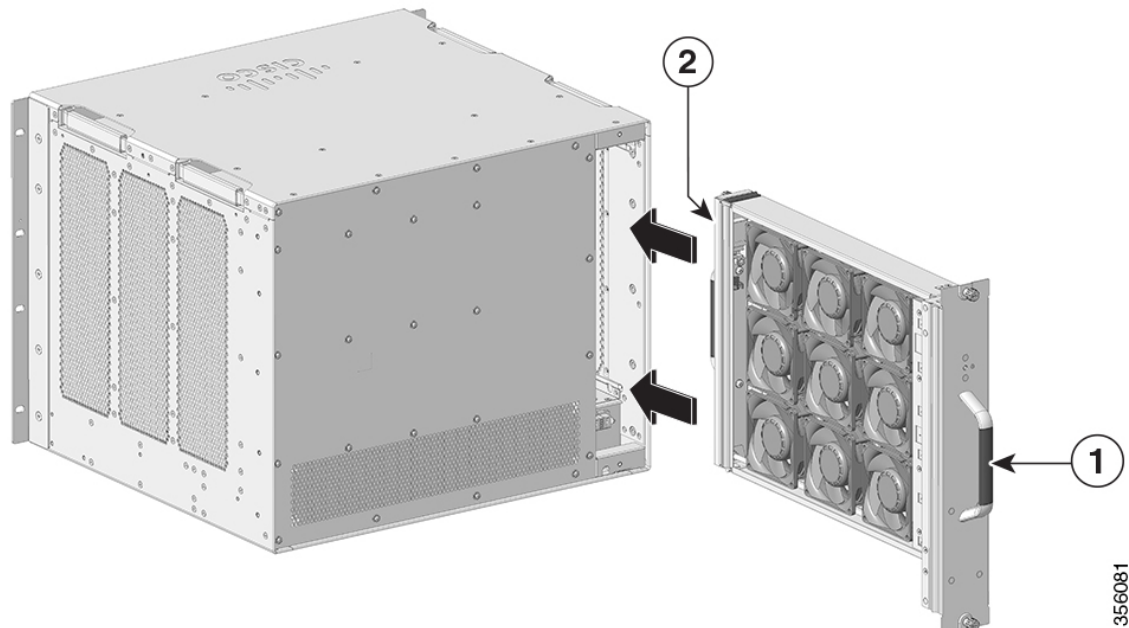
Before you begin

- Read [Guidelines for Removing and Installing a Fan Tray, on page 63](#).
- Enable the service mode on the chassis, if you are performing this task in a system that is powered on.
- Ensure that you have the following tools and accessories available:
 - Phillips-head screwdriver
 - Anti-static mat

Procedure

- Step 1** On the replacement fan tray assembly, ensure that the two screws securing the fantray to the connector (on the side with the fan STATUS LEDs) are tight. Be careful not to overtighten the screws.
- Step 2** Hold the fan tray assembly such that the side with the STATUS LED is inserted first.

Figure 38: Inserting the Fan Tray from the Rear of the Chassis



356081

1	Release handle on the front of the fan tray. Note Ensure that the captive installation screws on this side are tightened before sliding the fan tray in.	2	Rear panel of the fan tray. Note Tighten the captive installation screws on this side, after sliding the fan tray in.
---	------------------------------------------------------------------------------------------------------------------------------------------------------------------------	---	-------------------------------------------------------------------------------------------------------------------------------------

- Step 3** Place the fan tray into the fan tray bay so it rests on the chassis, and then lift the fan tray up slightly, aligning the top and bottom guides.
- Step 4** Slide the fan tray into the chassis until the two captive installation screws make contact with the chassis.
- Step 5** Tighten the two captive installation screws on the rear and secure the fan tray assembly in the chassis.

What to do next

Verify that you have installed the fan tray correctly. See [Verifying Fan Tray Installation, on page 73](#).

Verifying Fan Tray Installation

To verify that the new fan tray is installed correctly and is operating properly, follow these steps:

Before you begin

To check the operation of the fans, you should have powered up the chassis.

Procedure

- Step 1** Listen for the fans; you should immediately hear them operating. If you do not hear them, ensure
- That the fan tray is inserted completely in the chassis
 - That the faceplate is flush with the chassis panel.
 - That the captive installation screws have been tightened sufficiently.
- Important** If the fan tray is not installed correctly, the fans may not run at all, or they may run at full speed. When the fan tray operates at full speed, increased noise levels may be expected.
- Step 2** Check if the fan tray LED is lit and is green.
- Step 3** If after several attempts the fans do not operate, or if you experience trouble with the installation (for instance, if the captive installation screws do not align with the chassis holes), contact the Cisco TAC for assistance.



CHAPTER 5

Installing a Power Supply Unit

- [Required Tools and Equipment, on page 75](#)
- [Removing and Installing Power Supply Modules, on page 75](#)
- [Connecting to a Power Source, on page 82](#)
- [Verifying the Power Supply Installation, on page 86](#)
- [Removing and Installing Power Supply Blanks, on page 86](#)
- [Finding the Serial Number, on page 90](#)

Required Tools and Equipment

Obtain these tools:

- A Phillips-head screwdriver
- A 10-mm torque driver (with a 3-inch shaft, at a minimum)
- Wire-stripping tool
- Wire crimping tool

Removing and Installing Power Supply Modules

The chassis supports field-replaceable and hot-swappable AC-input and DC-input power supply modules. You can install a mix of AC-input and DC-input modules in the chassis. This section describes how to remove and install both kinds of modules

- In a redundant mode, you do not have to power down the switch to replace or upgrade the power supplies.
- In the combined mode, the module is still hot-swappable as long as the difference between total output power and the total used power is greater than the capacity of the module being removed.

Total output power – Total used > Capacity of power supply module being removed.



Warning When stranded wiring is required, use approved wiring terminations, such as closed-loop or spade-type with upturned lugs. These terminations should be the appropriate size for the wires and should clamp both the insulation and conductor.

Statement 1002



Warning Before performing any of the following procedures, ensure that power is removed from the DC circuit.

Statement 1003



Warning This product relies on the building's installation for short-circuit (overcurrent) protection. Ensure that the protective device is rated not greater than these values for US and EU:

- 20A circuit breakers for AC-input power supply.
- 50A DC-rated circuit breakers for each input for safety purposes - irrespective of whether the inputs are power from a single or separate DC sources.

Statement 1005



Warning This equipment has been designed for connection to TN and IT power systems.

Statement 1007



Warning A readily accessible two-poled disconnect device must be incorporated in the fixed wiring.

Statement 1022



Warning Use copper conductors only.

Statement 1025



Warning Only trained and qualified personnel should be allowed to install, replace, or service this equipment.

Statement 1030



Warning Ultimate disposal of this product should be handled according to all national laws and regulations.

Statement 1040



Warning This product requires short-circuit (overcurrent) protection, to be provided as part of the building installation. Install only in accordance with national and local wiring regulations.

Statement 1045



Warning No user-serviceable parts inside. Do not open.

Statement 1073



Warning Hazardous voltage or energy may be present on DC power terminals. Always replace cover when terminals are not in service. Be sure uninsulated conductors are not accessible when cover is in place.

Statement 1075

Removing a Power Supply Module

Before you begin



Warning Only trained and qualified personnel should be allowed to install, replace, or service this equipment. **Statement 1030**

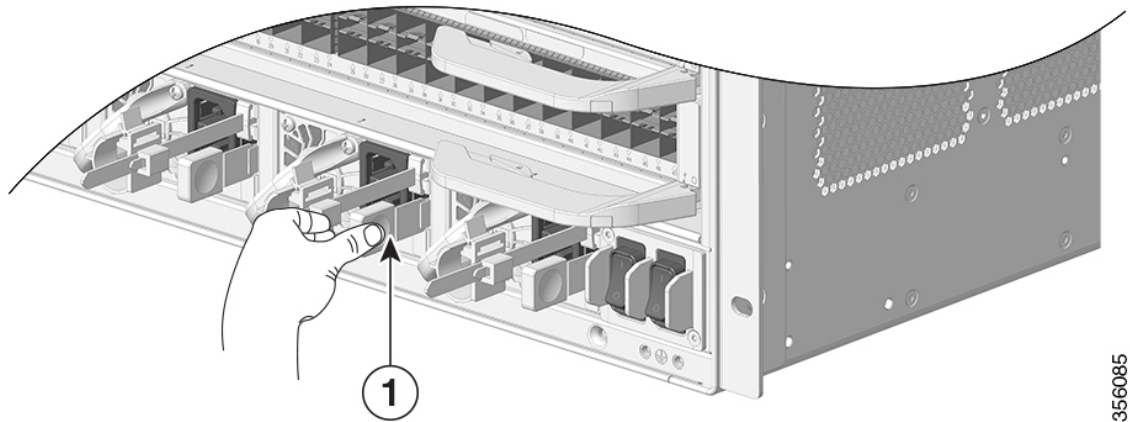


Warning No user-serviceable parts inside. Do not open. **Statement 1073**

Procedure

- Step 1** Turn the power switch of the designated power supply module to OFF (0) position
- Step 2** Loosen and remove the retainer strip that is around the power cord.
- Step 3** Remove the power cord from the power receptacle on the power supply.
- Step 4** Press the release latch at the right side of the power supply module inwards.

Figure 39: Detaching the Power Supply Module from the Slot



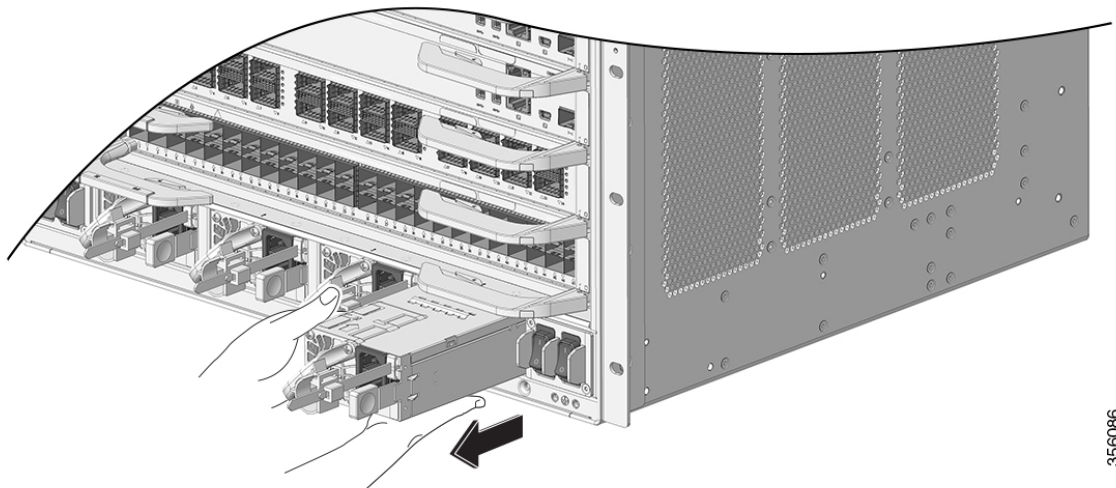
356085

1	Release latch
---	---------------

Step 5

Grasp the power supply module handle with one hand; place your other hand underneath to support the bottom of the power supply. Slide the power supply module out fully.

Figure 40: Sliding the Power Supply Module Out



356086

Caution Do not leave any power supply slot open for any amount of time while the system is powered up. Before inserting a new power supply unit, for instance, when replacing the unit, ensure that there are no foreign, conductive or other objects, or debris in the slot.

Warning In the course of its operation the system may require more than one power supply installed and supplying power. Should it become necessary to remove an active power supply unit from the system, consult the user manual for proper system administration of available power. In order to safely de-energize the power supply unit, the input power should first be turned off and the power cable physically disconnected from the unit. The unit must then be removed from the slot and stowed safely away in a proper antistatic bag. Care must be taken not to touch any of the exposed pins from the backplane connector. When a replacement power supply unit is to be installed, its power switch must always be in the OFF state and no input power cable be installed prior to inserting it into the slot. After the unit is seated, the input power cable may then be installed and fastened securely before switching on the power supply. **Statement 1028**

What to do next

Set the power supply aside and proceed with installing the new or replacement power supply module. Install blank covers in all power supply bays that are to remain empty (C9600-PWR-BLANK). For information about installing blank covers, see [Removing and Installing Power Supply Blanks, on page 86](#).

Installing a Power Supply Module

Before you begin



Warning Only trained and qualified personnel should be allowed to install, replace, or service this equipment. **Statement 1030**



Warning No user-serviceable parts inside. Do not open. **Statement 1073**

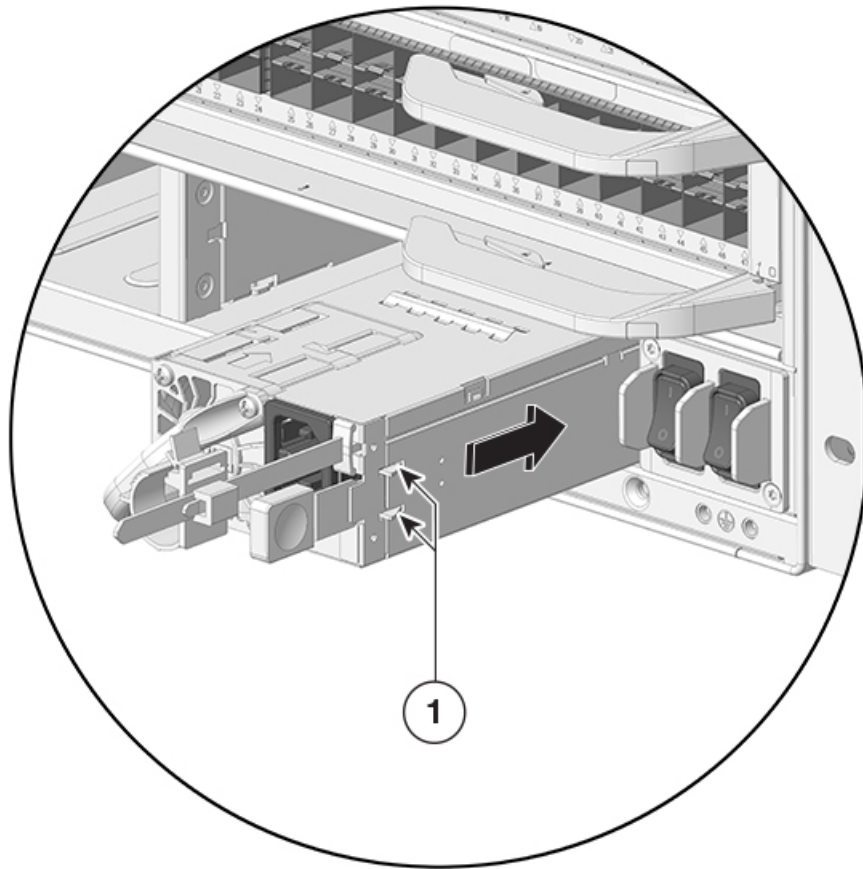
Ensure that you have installed the cable guide before you begin the procedure. This is to properly guide and arrange the power cords that you will attach as part of the installation.

Procedure

- Step 1** Remove the replacement power supply from its shipping packaging.
- Step 2** Verify that the power switch of the replacement power supply is in the OFF (0) position.
- Step 3** If installed, remove the blank power supply cover from the empty power supply bay. For information about removing blank covers, see [Removing and Installing Power Supply Blanks, on page 86](#). Save the blank cover for future use.
- Step 4** Grasp the power supply handle with one hand and place your other hand underneath to support the bottom of the power supply. Slide the power supply all the way into the power supply bay. Make sure that the power supply is fully seated in the bay.

When correctly installed, the latch on the power supply locks-in the module, to avoid accidental removal of the module.

Figure 41: Inserting the Power Supply into the Power Supply Bay

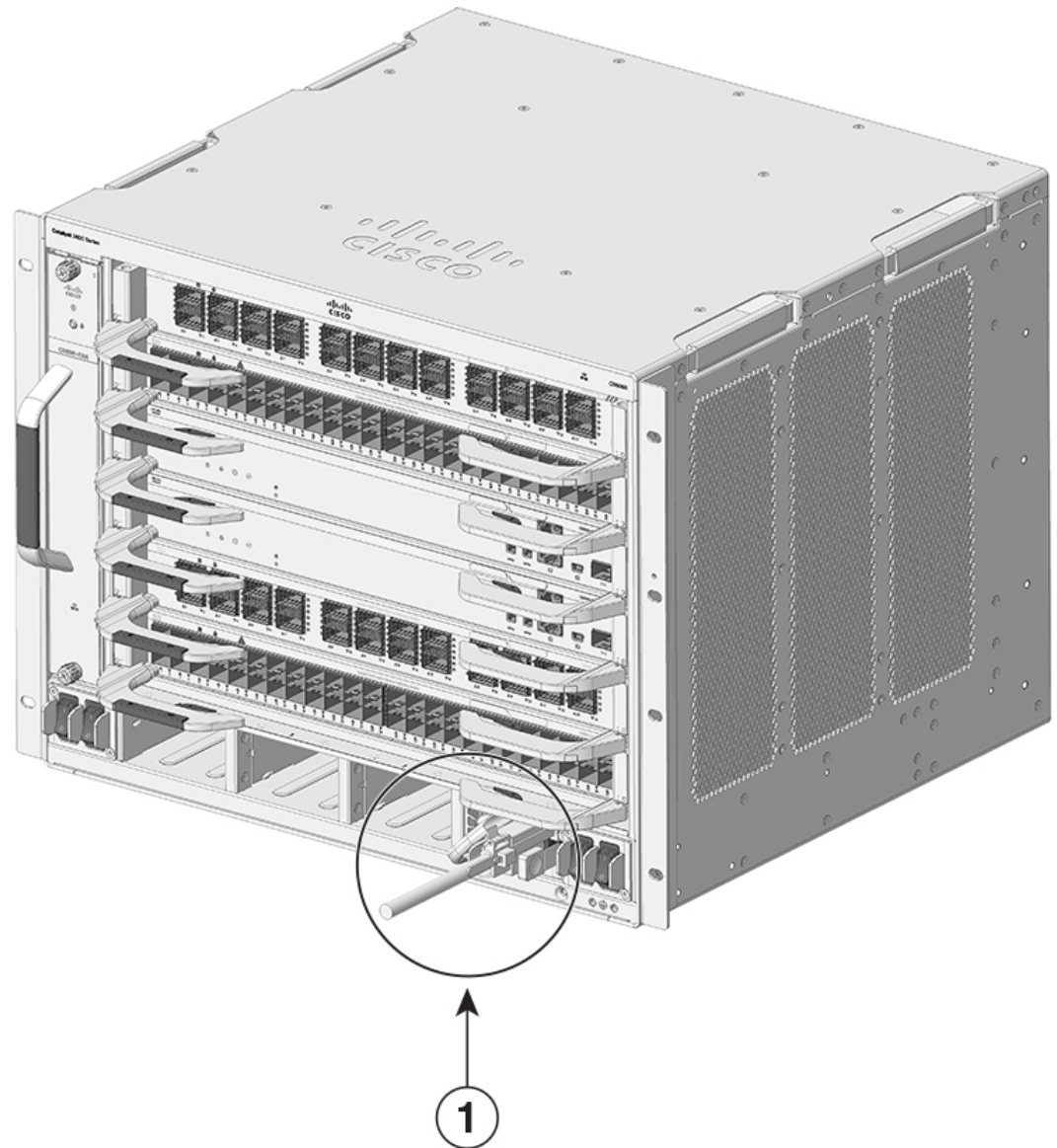


1	Power supply latches, which click into place
---	----------------------------------------------

Step 5 Verify that all site power and grounding requirements have been met.

Step 6 Verify that you have the correct power cord for your location and power supply rating and only then plug the power cord connector into the power supply receptacle.

Figure 42: Plugging in the Power Cord



356084

1	Power cord plugged into the receptacle
---	----------------------------------------

Step 7

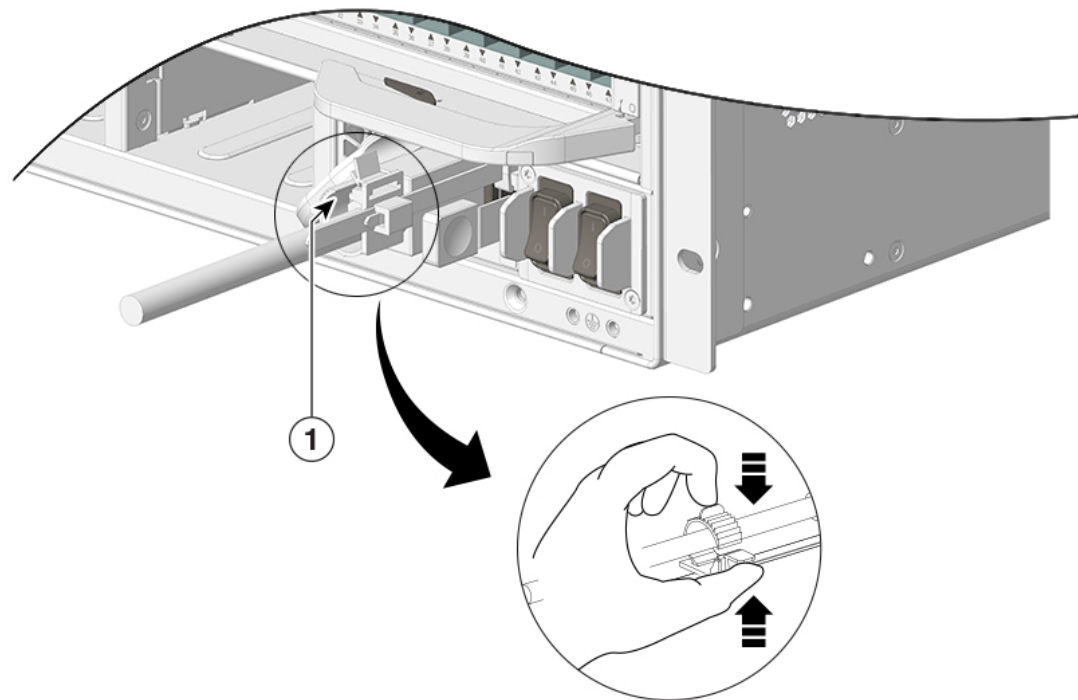
Follow the steps to install the power cord retainer, to hold it in place and avoid accidental removal.

- a) Fix the strap in the power cord retainer to the power supply module, to hold the clamp in place.
- b) Slide the retainer clamp around the power cord and position the retainer closest to the power supply.

Depending on the width of the power cord, adjust the size of the retainer clamp, if required.

- c) Press the tabs on the retainer clamp towards each other to secure the power cord.

Figure 43: Installing the Power Cord Retainer



356083

1	Power supply fully inserted into the chassis; power cord and retainer strapped into place.
---	--------------------------------------------------------------------------------------------

Step 8 Set the power switch to the ON (I) position

What to do next

Connect the power supply to the power source.

Connecting to a Power Source

The following sections provide information about connecting the chassis to an AC and DC power source.

Connecting to an AC Power Source

To connect to a power source, follow these steps:



Warning Take care when connecting units to the supply circuit so that wiring is not overloaded. **Statement 1018**

Procedure

- Step 1** Prior to connecting the power supply to a power source, ensure that the chassis is properly grounded.
- Step 2** Plug the power cable into the power supply.
- Step 3** Plug the other end of the power cable into a power source supplied by the data center.
- Note** When using redundant mode, connect each power supply to a separate power source.
- Step 4** Verify that the power supply is receiving power by checking that the LED is on and is green. For more information about the power supply LEDs and the conditions that they indicate, see [Power Supply Modules LEDs, on page 101](#).

When you first activate the power supply, you can verify the functionality of the LED by checking that LED turns on for a couple of seconds. If the LED is flashing amber or green, check the power connections on the power supply and the power source.

Connecting to a DC Power Source

To connect the DC power supply directly to one or two DC power sources, follow these steps:



Warning Before performing any of the following procedures, ensure that power is removed from the DC circuit. **Statement 1003**

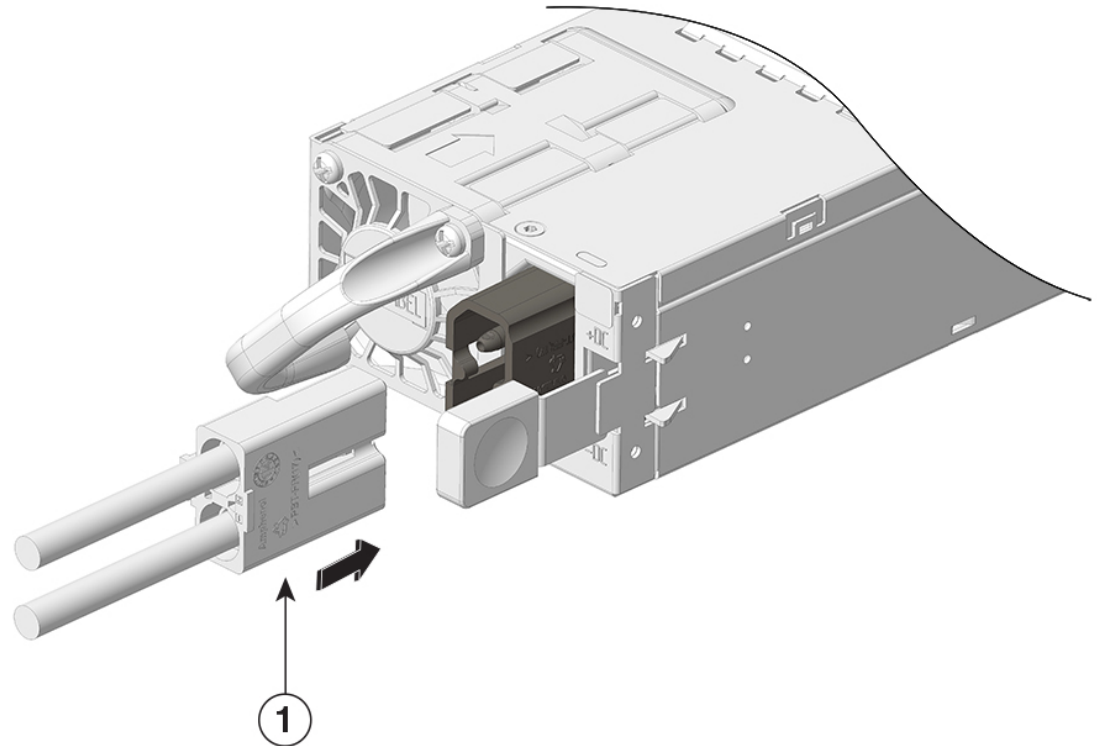


Warning Hazardous voltage or energy may be present on DC power terminals. Always replace cover when terminals are not in service. Be sure uninsulated conductors are not accessible when cover is in place. **Statement 1075.**

Procedure

- Step 1** Prior to connecting the power supply to a power source, ensure that the chassis is properly grounded.
- Step 2** Plug the DC power cable into the DC power receptacle on the power supply module.

Figure 44: Plugging in the DC Power Cable



356094

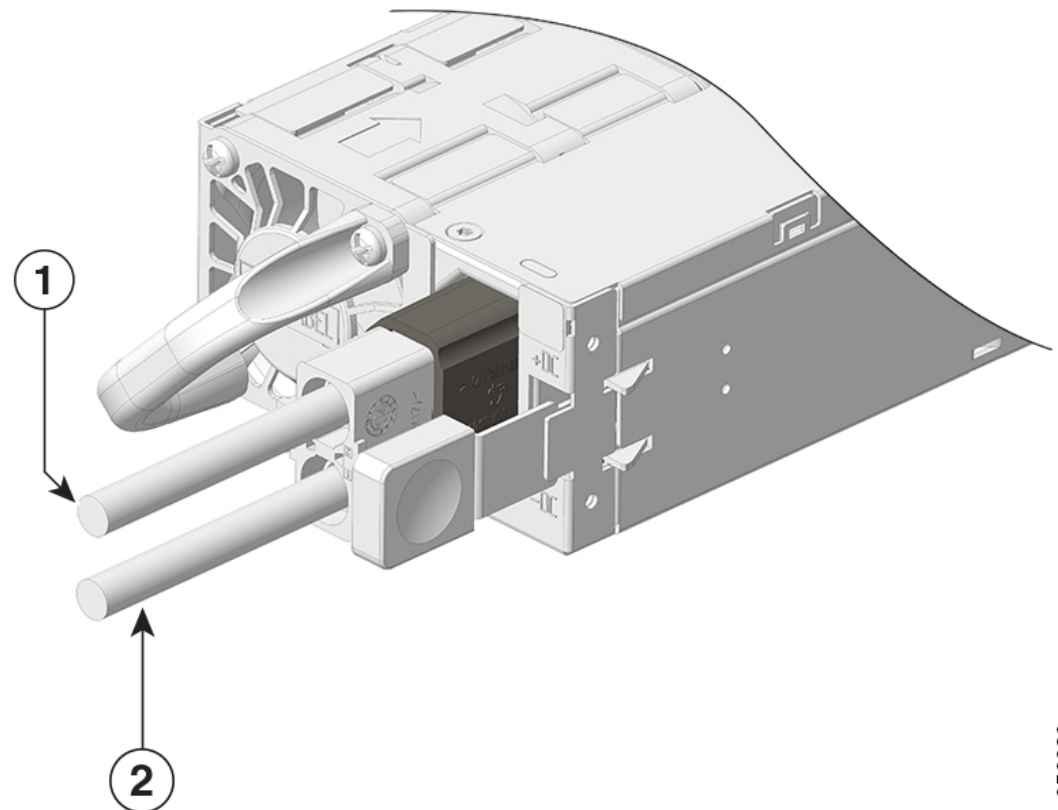
1	Power Cable
---	-------------

Step 3 Turn off the power at the circuit breakers for the portions of the DC grid power that you are connecting to and verify that all of the LEDs on the DC grid power supplies are off.

Step 4 Install the two cables from the DC power cable to a DC power source as follows:

- a) If the unconnected end of each power cable is not stripped of its insulation for the last 0.75 inches (19 mm), use wire strippers to remove that amount of insulation.
- b) Attach the negative cables to the negative terminals of a DC power source, and attach the positive cables to the positive terminals of the same power source.

Figure 45: Attaching the Cable to the Power Source



356093

1	Positive terminal	2	Negative terminal
---	-------------------	---	-------------------

Note If you are using combined power mode or power supply redundancy mode, connect all the power supplies in the chassis to the same power source. If you are using input source redundancy mode or full redundancy mode, connect half the power supplies to one DC power source and the other half of the power supplies to another DC power source.

Step 5 Verify that the power supply is receiving power by checking that the LED is on and is green.

When you first activate the power supply, you can verify the functionality of the LED by checking that LED turns on for a couple of seconds. If the LED is flashing amber or green, check the power connections on the power supply and the power source.

Verifying the Power Supply Installation

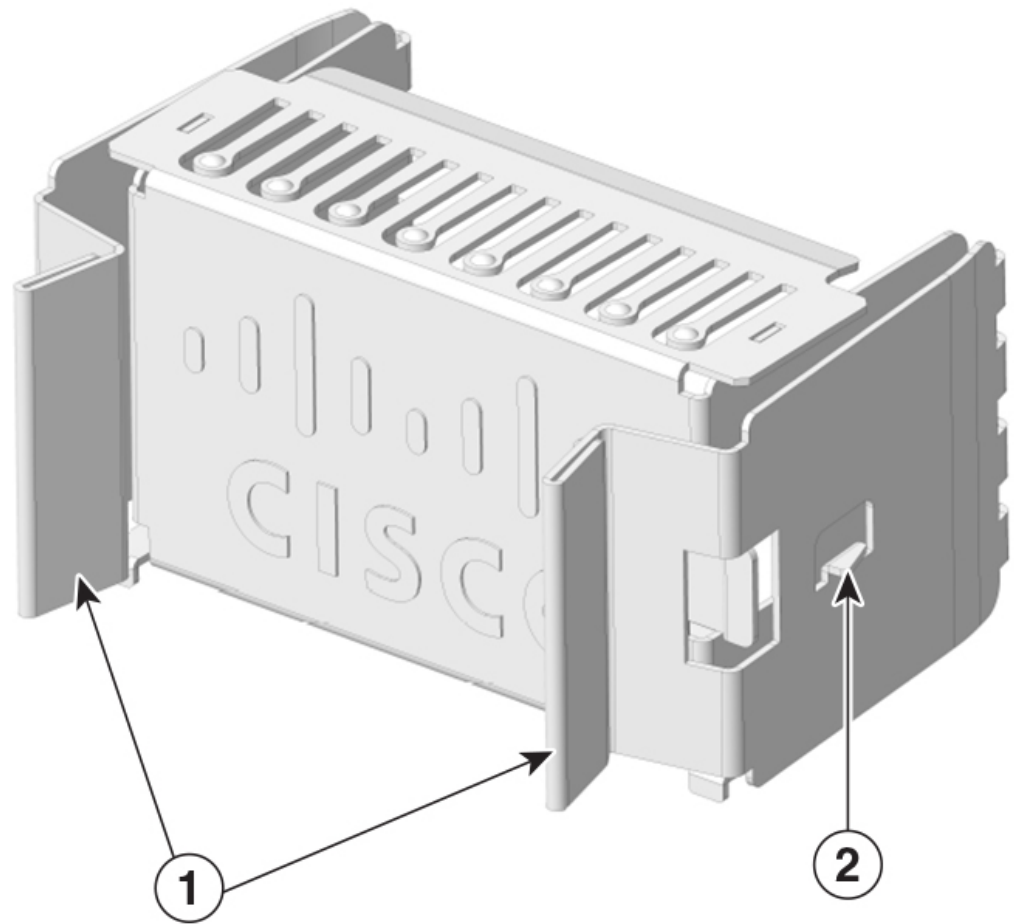
Procedure

- Step 1** Verify the power supply operation by checking the power supply's front-panel LED. See [Power Supply Modules LEDs, on page 101](#).
- Step 2** Check the power supply and system status from the system console by entering **show power** command in privileged EXEC mode.
- ```
Switch# show power
```
- Step 3** If the LEDs or **show power** command output indicate a power problem or other system problem, see the *Troubleshooting* section for more information.
- 

## Removing and Installing Power Supply Blanks

If a power supply bay in a chassis is unused, you must cover it with a power supply blank cover to maintain proper airflow through the chassis. (Part number C9606-PWR-BLANK=).

Figure 46: Front View of a Power Supply Blank Cover



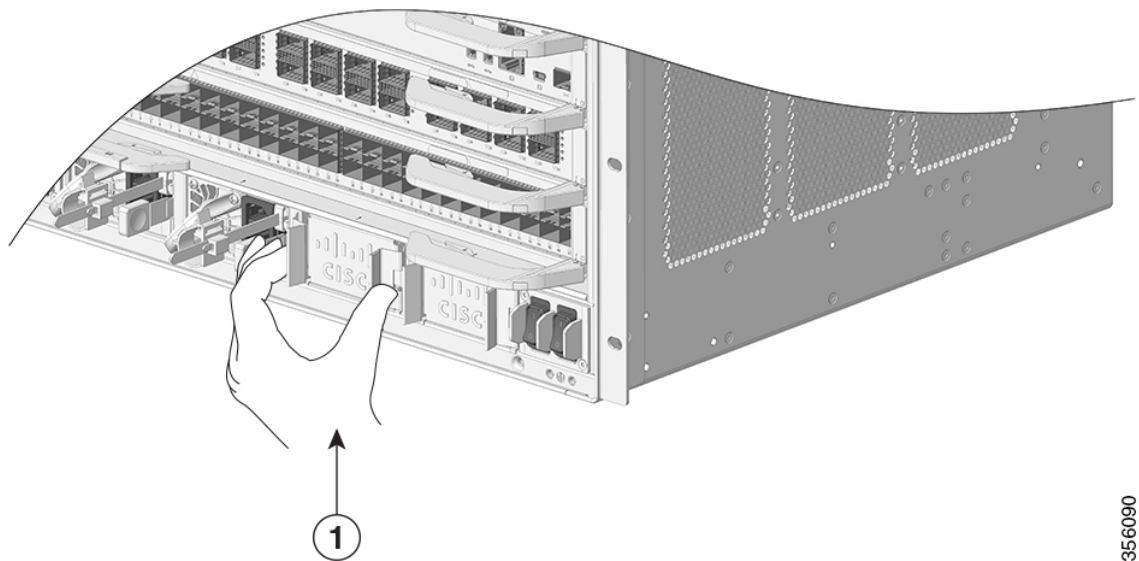
356087

|   |                 |   |               |
|---|-----------------|---|---------------|
| 1 | Release handles | 2 | Retainer clip |
|---|-----------------|---|---------------|

### Removing a Power Supply Blank Cover

To remove the blank cover from a bay, use the release handles to hold the blank cover (with your thumb and index fingers), squeeze both the handles toward each other and slide the cover out of the bay.

Figure 47: Removing a Power Supply Blank Cover



356090

|   |                                                     |
|---|-----------------------------------------------------|
| 1 | Release handles that are squeezed toward each other |
|---|-----------------------------------------------------|

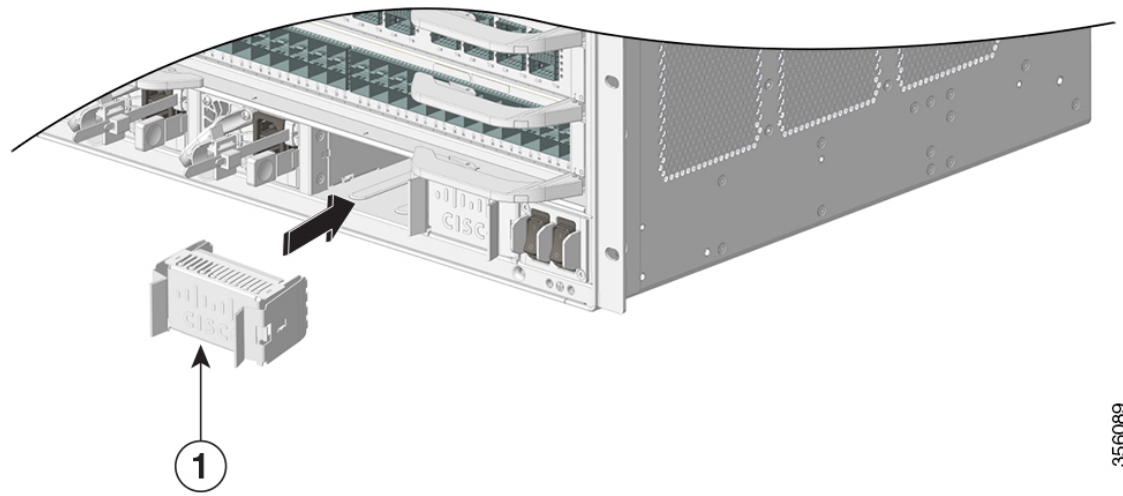
**Caution**

Do not leave any power supply slot open for any amount of time while the system is powered up. Prior to inserting a new power supply unit, for instance, when replacing the unit, ensure there are no foreign, conductive or other objects, or debris in the slot.

**Installing a Power Supply Blank Cover**

To install a power supply blank cover, push the blank cover straight and into the bay. You will hear retainer clips snap into place when installed correctly. You can hold the blank cover by the outside edges when you perform this task; alternatively, use the release handles to hold the blank cover.

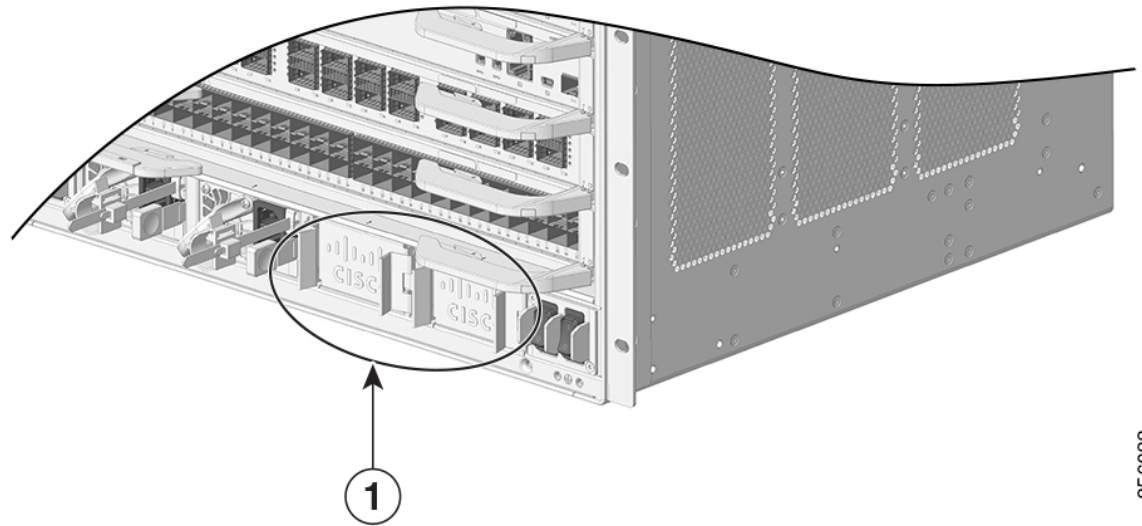
Figure 48: Installing a Power Supply Blank Cover



356089

|   |                    |
|---|--------------------|
| 1 | Power supply blank |
|---|--------------------|

Figure 49: Power Supply Blank Cover Installed



356088

|   |                                        |
|---|----------------------------------------|
| 1 | Power supply blanks after installation |
|---|----------------------------------------|

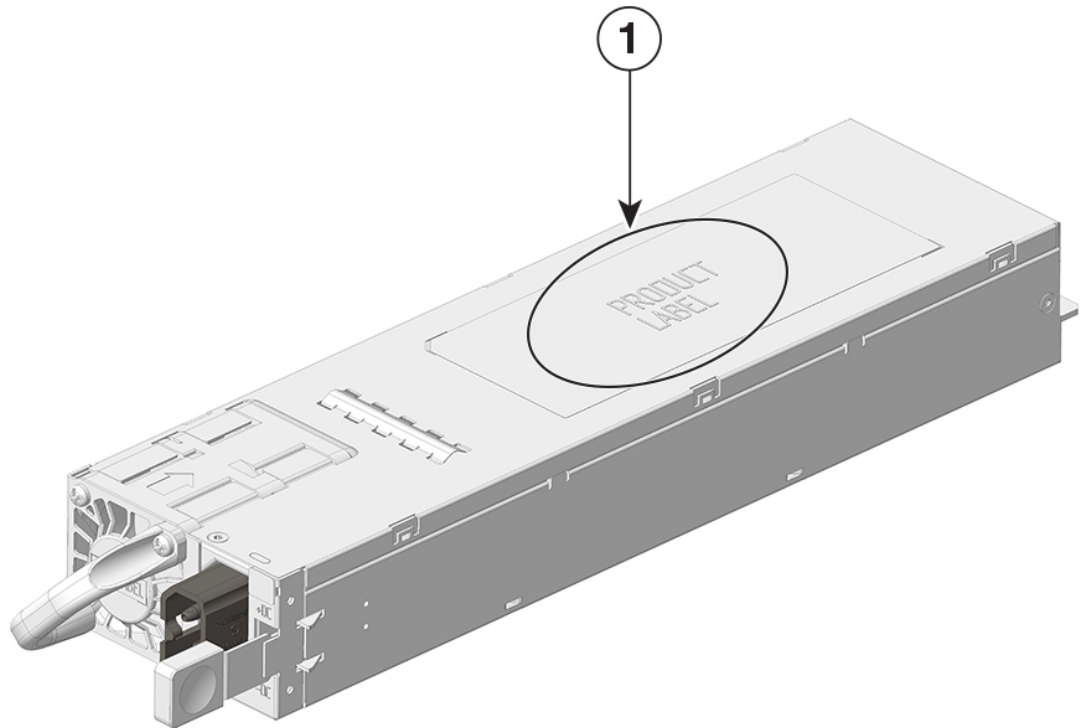


**Note** Power supply blank covers can be placed in any slot when fewer than 4 power supplies are installed in a chassis.

# Finding the Serial Number

If you contact Cisco Technical Assistance, you need to know the serial number. These figures show where the serial number is located. You can also use the **show version** privileged EXEC command to see the serial number.

**Figure 50: Serial Number on the Power Supply Module**



356092

|   |                                   |   |   |
|---|-----------------------------------|---|---|
| 1 | Power supply module serial number | - | - |
|---|-----------------------------------|---|---|



# APPENDIX **A**

## Technical Specifications

- [C9606R Switch Chassis Specifications, on page 91](#)
- [Power Supply Specifications, on page 93](#)
- [Chassis and Module Power and Heat Values, on page 98](#)
- [Weight Specifications, on page 99](#)

### C9606R Switch Chassis Specifications

**Table 5: Physical Specifications of the Chassis**

| Item                                                     | Specification                                        |
|----------------------------------------------------------|------------------------------------------------------|
| Dimensions (H x W x D)                                   | 13.95 X 17.4 X 16.1 inches (35.43 x 44.2 x 40.9 cms) |
| Rack units (RU <sup>4</sup> )                            | 8 RU                                                 |
| Weight (Chassis with two AC power supplies and fan tray) | 63.0 lb (31.31 kg)                                   |

<sup>4</sup> The chassis height is measured in rack units (RU or just U), where 1 RU or 1 U equals 1.75 in (44.45 mm).

**Table 6: Environmental Specifications of the Chassis**

| Item                                                                                | Specification                                                                                                                                                                     |
|-------------------------------------------------------------------------------------|-----------------------------------------------------------------------------------------------------------------------------------------------------------------------------------|
| Ambient temperature and altitude for normal operations <sup>5</sup>                 | <ul style="list-style-type: none"> <li>• 23° to 113°F (-5 to +45°C), up to 6,000 feet (1800 m)</li> <li>• 23° to 104°F (-5 to +40°C), up to 10,000 feet (3000 m)</li> </ul>       |
| Ambient temperature and altitude for short-term <sup>6</sup> exceptional conditions | <ul style="list-style-type: none"> <li>• 23°F to 122°F (-5°C to +50°C), up to 6,000 feet (1800 m)</li> <li>• 23°F to 122°F (-5°C to +45°C), up to 10,000 feet (3000 m)</li> </ul> |
| Nonoperating and storage temperature                                                | -40° to 167°F (-40° to 75°C)                                                                                                                                                      |

| Item                                        | Specification                                                                                                                                                                                                                          |                                                                          |                |
|---------------------------------------------|----------------------------------------------------------------------------------------------------------------------------------------------------------------------------------------------------------------------------------------|--------------------------------------------------------------------------|----------------|
| Thermal transition                          | Hot to cold—at a maximum rate of 86°F (30°C) per hour<br>Cold to hot—at maximum rate of 204.8°F (96°C) per hour                                                                                                                        |                                                                          |                |
| Humidity (RH), ambient (noncondensing)      | Operating, nonoperating and storage —10 to 95 percent                                                                                                                                                                                  |                                                                          |                |
| Altitude (operating and nonoperating)       | -60 to 3000m (-197 to 9843 feet)                                                                                                                                                                                                       |                                                                          |                |
| Sound power level (LwAD)                    | LwAD—74.7 dBA<br>This is with four power supply modules installed and delivering 50 percent of rated output power; measured according to International Organization for Standardization (ISO) 7779 and declared according to ISO 9296. |                                                                          |                |
| Airflow                                     | Chassis—Right to left (when facing the front of the chassis)<br>Power supply—Front to back (forward air flow)                                                                                                                          |                                                                          |                |
| Shock                                       | Operating—5G 11ms (Half-sine)<br>Nonoperating and storage— 15G 11ms (Half-sine)                                                                                                                                                        |                                                                          |                |
| Sine Vibration                              | <ul style="list-style-type: none"> <li>• Operating— 0.15G (10Hz-500Hz)</li> <li>• Nonoperating and storage— 0.8G (10Hz-500Hz)</li> </ul>                                                                                               |                                                                          |                |
| Random Vibration (Operating)                | <b>Spectral Break Point Frequencies</b>                                                                                                                                                                                                | <b>Acceleration Spectral Density</b>                                     | <b>Slope</b>   |
|                                             | 2.5 – 5 Hz                                                                                                                                                                                                                             | -                                                                        | 6 db /octave   |
|                                             | 5 – 100 Hz                                                                                                                                                                                                                             | 0.1 [(m/s <sup>2</sup> ) <sup>2</sup> ]/Hz<br>(0.001 g <sup>2</sup> /Hz) | -              |
|                                             | 100 – 200 Hz                                                                                                                                                                                                                           | -                                                                        | -24 db /octave |
| Random Vibration (Nonoperating and Storage) | <b>Spectral Break Point Frequencies</b>                                                                                                                                                                                                | <b>Acceleration Spectral Density</b>                                     | <b>Slope</b>   |
|                                             | 2.5 – 5 Hz                                                                                                                                                                                                                             | -                                                                        | 6 db /octave   |
|                                             | 5 – 100 Hz                                                                                                                                                                                                                             | 1.0 [(m/s <sup>2</sup> ) <sup>2</sup> ]/Hz*<br>(0.01 g <sup>2</sup> /Hz) | -              |
|                                             | 100 – 200 Hz                                                                                                                                                                                                                           | -                                                                        | -24 db /octave |

<sup>5</sup> Minimum ambient temperature for cold startup is 0°C

<sup>6</sup> Short-term exceptional conditions are for no longer than a one-year period of—96 consecutive hours, or 360 hours total, or 15 occurrences.



# Power Supply Specifications

## 2000W AC-Input Power Supply Specifications

The following table lists specifications for the 2000W AC input power supply:

**Table 7. 2000W AC-Input Power Supply Specifications**

| Specification              | Description                                                                                                                                                                                                                                                                                                                                                                                                                                                                                                                                                                                                                                                                                                                                                                                                                                              |
|----------------------------|----------------------------------------------------------------------------------------------------------------------------------------------------------------------------------------------------------------------------------------------------------------------------------------------------------------------------------------------------------------------------------------------------------------------------------------------------------------------------------------------------------------------------------------------------------------------------------------------------------------------------------------------------------------------------------------------------------------------------------------------------------------------------------------------------------------------------------------------------------|
| AC-input type              | Wide-ranging input with power factor correction.<br><br><b>Note</b> Power factor correction is a standard feature on AC-input power supplies. Power factor correction reduces the reactive component in the source AC current, allowing higher power factors and lower harmonic current components.                                                                                                                                                                                                                                                                                                                                                                                                                                                                                                                                                      |
| AC-input voltage           | Low-line (115 VAC nominal)—90VAC (min) to 140VAC (max)<br>High-line (230 VAC nominal)—180VAC (min) to 264VAC (max)                                                                                                                                                                                                                                                                                                                                                                                                                                                                                                                                                                                                                                                                                                                                       |
| AC-input current           | 10.5A at 115VAC (1050W output)<br>7.8A at 230 VAC (2000W output)                                                                                                                                                                                                                                                                                                                                                                                                                                                                                                                                                                                                                                                                                                                                                                                         |
| AC-input frequency         | 50/60Hz nominal (47 to 63Hz full range)                                                                                                                                                                                                                                                                                                                                                                                                                                                                                                                                                                                                                                                                                                                                                                                                                  |
| Branch circuit requirement | Each chassis power supply should have its own dedicated, fused-branch circuit: <ul style="list-style-type: none"> <li>• North America—15 A.</li> <li>• International—Circuits sized to local and national codes.</li> <li>• All AC power supply inputs are fully isolated.                             <ul style="list-style-type: none"> <li>• Source AC can be out of phase between multiple power supplies in the same chassis, which means that PS1 can be operating from phase A and PS2 can be operating from phase B.</li> <li>• For high-line operation, the power supply operates with the line conductor wired to an source AC phase, and the Neutral conductor wired either to a Neutral, single-phase power system, or to another source AC phase as long as the net input voltage is in the range of 180 to 264 VAC.</li> </ul> </li> </ul> |
| Power supply output        | <ul style="list-style-type: none"> <li>• 100 to 120 VAC operation                             <ul style="list-style-type: none"> <li>• 12V output — 1050W</li> </ul> </li> <li>• 200 to 240 VAC operation                             <ul style="list-style-type: none"> <li>• 12V output — 2000W</li> </ul> </li> </ul>                                                                                                                                                                                                                                                                                                                                                                                                                                                                                                                                 |
| Output holdup time         | 20 ms minimum with 1200W output                                                                                                                                                                                                                                                                                                                                                                                                                                                                                                                                                                                                                                                                                                                                                                                                                          |

| Specification                                     | Description                        |
|---------------------------------------------------|------------------------------------|
| kVA rating <sup>7</sup>                           | 2250W maximum (total output power) |
| Heat dissipation (in British Thermal Units (BTU)) | 683 BTU per hour                   |
| Weight                                            | 2.65 lb (1.2 kg)                   |

<sup>7</sup> The kVA rating listed for the power supply should be used as the sizing criteria for both UPS outputs as well as standard circuits and transformers to power a switch

## 2000WAC Power Supply AC Power Cords

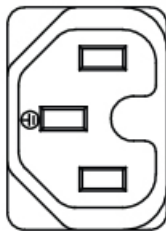
The following table lists the specifications for the AC power cords that are available for the 2000W AC-input power supply. The table also includes references to power cord illustrations.



**Note** All 2000W power supply power cord:

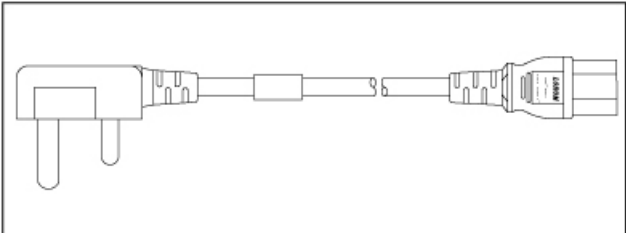
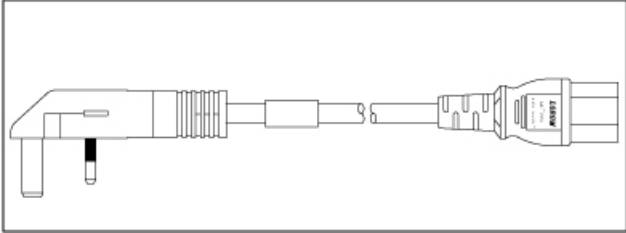
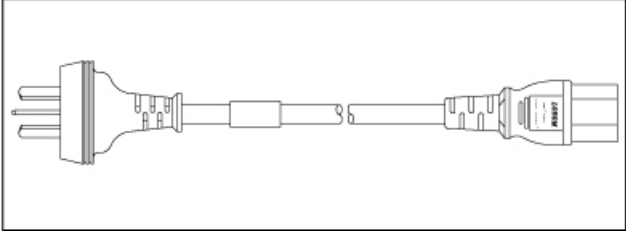
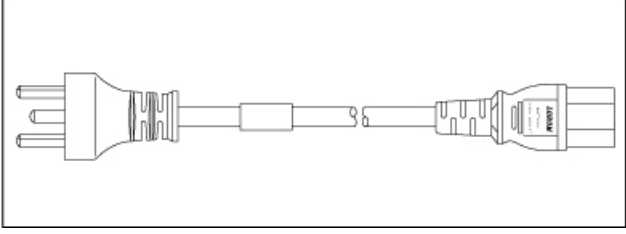
- Lengths range from 9.84 – 14 feet (3.0 – 4.293 meters); with most cord lengths between 13 and 14 feet (4.013 and 4.293 meters)
- Have an IEC60320/C15 appliance connector at one end.

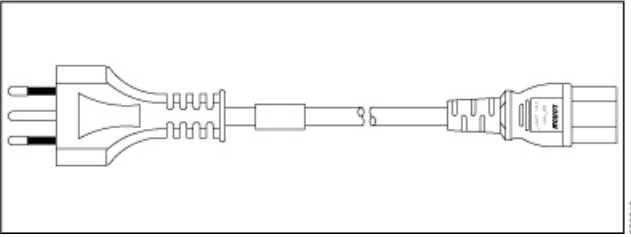
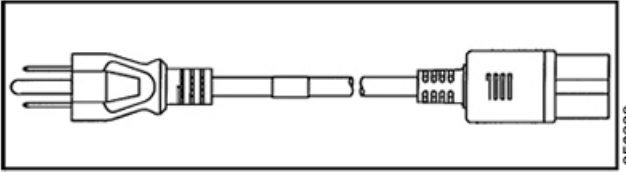
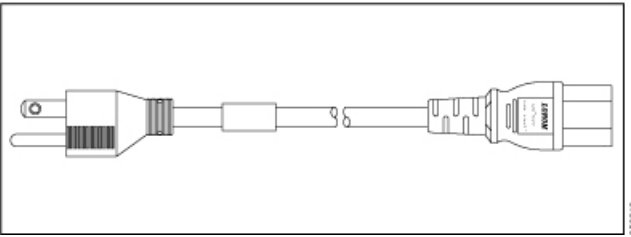
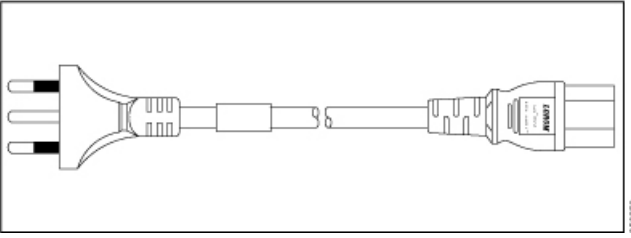

*Figure 51: IEC60320/C15 Appliance Connector*

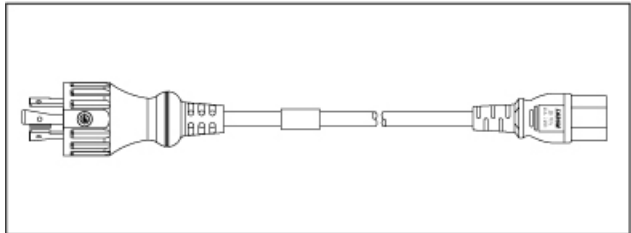
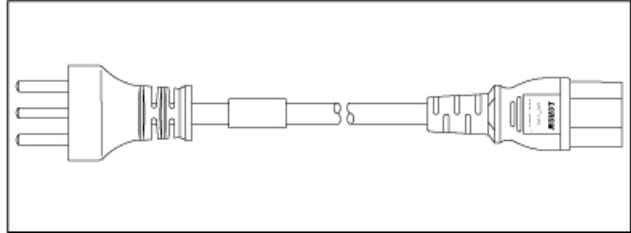
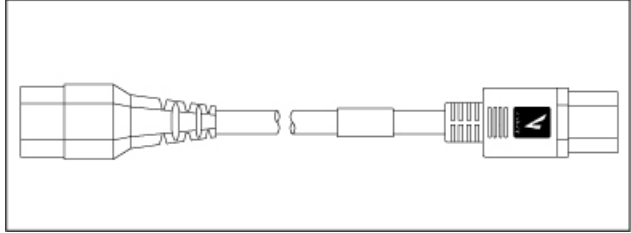
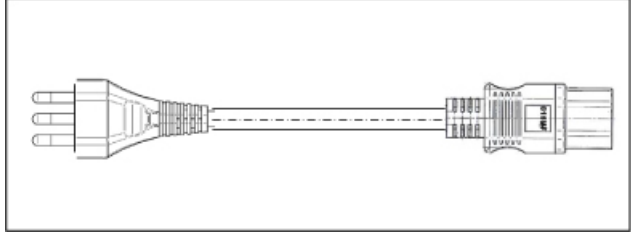


*Table 8: 2000 W Power Supply AC Power Cords*

| Locale             | Part Number | Cordset Rating | AC Source Plug Type                                      |
|--------------------|-------------|----------------|----------------------------------------------------------|
| Continental Europe | CAB-TA-EU   | 250 VAC, 10 A  | <p><i>Figure 52: CAB-TA-EU= (Continental Europe)</i></p> |

| Locale         | Part Number | Cordset Rating | AC Source Plug Type                                                                                                                                                                                              |
|----------------|-------------|----------------|------------------------------------------------------------------------------------------------------------------------------------------------------------------------------------------------------------------|
| South Africa   | CAB-TA-IN   | 250 VAC, 10 A  | <p data-bbox="889 289 1211 317"><i>Figure 53: CAB-TA-IN= (South Africa)</i></p>  <p data-bbox="1516 541 1531 579">956046</p>   |
| United Kingdom | CAB-TA-UK   | 250 VAC, 10 A  | <p data-bbox="889 615 1247 642"><i>Figure 54: CAB-TA-UK= (United Kingdom)</i></p>  <p data-bbox="1516 867 1531 905">956051</p> |
| China          | CAB-TA-CN   | 250 VAC, 10 A  | <p data-bbox="889 940 1162 968"><i>Figure 55: CAB-TA-CN= (China)</i></p>  <p data-bbox="1516 1192 1531 1230">956045</p>       |
| Denmark        | CAB-TA-DN   | 250 VAC, 10 A  | <p data-bbox="889 1266 1190 1293"><i>Figure 56: CAB-TA-DN= (Denmark)</i></p>  <p data-bbox="1516 1518 1531 1556">956044</p>  |

| Locale        | Part Number    | Cordset Rating | AC Source Plug Type                                                                                                                                                                                                |
|---------------|----------------|----------------|--------------------------------------------------------------------------------------------------------------------------------------------------------------------------------------------------------------------|
| Italy         | CAB-TA-IT      | 250 VAC, 10 A  | <p data-bbox="852 289 1101 317"><i>Figure 57: CAB-TA-IT= (Italy)</i></p>  <p data-bbox="1484 548 1495 583">356288</p>            |
| Japan         | CAB-TA-JP      | 125 VAC, 12 A  | <p data-bbox="852 613 1122 640"><i>Figure 58: CAB-TA-JP= (Japan)</i></p>  <p data-bbox="1484 785 1495 852">356289</p>            |
| North America | CAB-TA-NA      | 125 VAC, 12 A  | <p data-bbox="852 892 1198 919"><i>Figure 59: CAB-TA-NA= (North America)</i></p>  <p data-bbox="1484 1150 1495 1186">356290</p> |
| Sweden        | CAB-TA-SW      | 250 VAC, 10 A  | <p data-bbox="852 1215 1146 1243"><i>Figure 60: CAB-TA-SW= (Sweden)</i></p>  <p data-bbox="1484 1476 1495 1512">356290</p>     |
| Japan         | CAB-C15-CBN-JP | 250 VAC, 12 A  | <p data-bbox="852 1539 1170 1566"><i>Figure 61: CAB-C15-CBN-JP=(Japan)</i></p>  <p data-bbox="1435 1667 1446 1724">356290</p>  |

| Locale                     | Part Number    | Cordset Rating | AC Source Plug Type                                                                                                                   |
|----------------------------|----------------|----------------|---------------------------------------------------------------------------------------------------------------------------------------|
| Japan                      | CAB-TA-250V-JP | 250 VAC, 15 A  | <p><i>Figure 62: CAB-TA-250V-JP= ( )</i></p>        |
| Israel                     | CAB-TA-IS      | 250 VAC, 16 A  | <p><i>Figure 63: CAB-TA-IS= (Israel)</i></p>        |
| All countries except Japan | CAB-C15-CBN    | 250 VAC, 13 A  | <p><i>Figure 64: CAB-C15-CBN=( )</i></p>           |
| Brazil                     | CAB-ACBZ-12A   | 125 VAC, 12 A  | <p><i>Figure 65: CAB-ACBZ-12A = (Brazil)</i></p>  |

## 2000W DC-Input Power Supply Specifications

The following table lists specifications for the 2000W DC input power supply:

Table 9: 2000W DC-Input Power Supply Specifications

| Specification                                     | Description                                                                                                                                                                                                                                                                                                                                                                                              |
|---------------------------------------------------|----------------------------------------------------------------------------------------------------------------------------------------------------------------------------------------------------------------------------------------------------------------------------------------------------------------------------------------------------------------------------------------------------------|
| DC-input voltage                                  | -40 to -72VDC, with extended range to -75VDC                                                                                                                                                                                                                                                                                                                                                             |
| DC-input current                                  | Maximum: 50A per DC input at -48VDC input                                                                                                                                                                                                                                                                                                                                                                |
| Power supply output capacity                      | For 12VDC output—2000W                                                                                                                                                                                                                                                                                                                                                                                   |
| Output holdup time                                | 5ms with 1200W output                                                                                                                                                                                                                                                                                                                                                                                    |
| Temperature                                       | <ul style="list-style-type: none"> <li>Steady State Operating: -5°C to 45°C</li> <li>Non-operating: -40°C to +70°C</li> </ul>                                                                                                                                                                                                                                                                            |
| Humidity                                          | <ul style="list-style-type: none"> <li>Operating: 5 to 90 percent, non-condensing</li> <li>Non-operating: 5 to 95 percent, non-condensing</li> </ul>                                                                                                                                                                                                                                                     |
| Altitude                                          | <ul style="list-style-type: none"> <li>Operating: -500 to 10,000 feet over allowable temperature range (-5 to +45°C) and full load, de-rating 1.4°C per 1000 feet above 6,000 feet</li> </ul> <p><b>Note</b> The operating altitude in China is 6,561.6 ft. (2000 m) maximum</p> <ul style="list-style-type: none"> <li>Non-operating: -1,000 to 50,000 feet over allowable temperature range</li> </ul> |
| Heat dissipation (in British Thermal Units (BTU)) | 932 BTU per hour (maximum)                                                                                                                                                                                                                                                                                                                                                                               |
| Weight                                            | 2.82 lb (1.28 kg)                                                                                                                                                                                                                                                                                                                                                                                        |

## Chassis and Module Power and Heat Values

The following tables provide the power and heat dissipation data. Unless otherwise noted, the information in the tables is measured under fully loaded conditions (transceivers installed).



**Note** DC output power is the output from the power supply (internal to the system). The AC-input power is the input from the outlet to the power supply. The percentage difference between the two values is the efficiency of the power supply.

**Table 10: Power Requirements and Heat Dissipation - Fan Tray**

| PID       | AC-Input Power in Watts (Power Allocated) | DC-Output in Watts (Power Requested) | Current @ 90V | Current @ 120V | Current @ 180V | Current @ 240V | Heat Diss. in BTU / hr. |
|-----------|-------------------------------------------|--------------------------------------|---------------|----------------|----------------|----------------|-------------------------|
| C9606-FAN | 500                                       | 450                                  | 5.6           | 4.2            | 2.8            | 2.1            | 1706                    |

**Table 11: Power Requirements and Heat Dissipation - Supervisor Module**

| PID         | AC-Input Power in Watts (Power Allocated) | DC-Output in Watts (Power Requested) | Current @ 90V | Current @ 120V | Current @ 180V | Current @ 240V | Heat Diss. in BTU / hr. |
|-------------|-------------------------------------------|--------------------------------------|---------------|----------------|----------------|----------------|-------------------------|
| C9600-SUP-1 | 862                                       | 775                                  | 9.6           | 7.2            | 4.8            | 3.6            | 2942                    |

**Table 12: Power Requirements and Heat Dissipation— Line Cards**

| PID           | AC-Input Power in Watts (Power Allocated) | DC-Output in Watts (Power Requested) | Current @ 90V | Current @ 120V | Current @ 180V | Current @ 240V | Heat Diss. in BTU / hr. |
|---------------|-------------------------------------------|--------------------------------------|---------------|----------------|----------------|----------------|-------------------------|
| C9600-LC-48YL | 256                                       | 230                                  | 2.9           | 2.2            | 1.5            | 1.1            | 874                     |
| C9600-LC-24C  | 223                                       | 200                                  | 2.5           | 1.9            | 1.3            | 1              | 761                     |

## Weight Specifications

The total weight of a fully configured chassis will depend on the type of chassis, the number of modules, and power supplies installed. Use the corresponding weights in the tables below to arrive at the total chassis weight for your hardware configuration.

### Chassis Weights

| PID (add = for spare) | Weight (Chassis without Fan Tray and Power Supply Units) |
|-----------------------|----------------------------------------------------------|
| C9606R                | 55.90 lb (25.36 kg)                                      |

**Supervisor Module Weight**

| <b>PID (add = for spare)</b> | <b>Weight</b>      |
|------------------------------|--------------------|
| C9600-SUP-1                  | 12.02 lb (5.45 kg) |

**Line Card Weights**

| <b>PID (add = for spare)</b> | <b>Weight</b>     |
|------------------------------|-------------------|
| C9600-LC-48YL                | 7.83 lb (3.55 kg) |
| C9600-LC-24C                 | 7.67 lb (3.48 kg) |

**Power Supply Module Weights**

| <b>PID (add = for spare)</b> | <b>Weight</b>     |
|------------------------------|-------------------|
| C9600-PWR-2KWAC              | 2.65 lb (1.2 kg)  |
| C9600-PWR-2KWDC              | 2.82 lb (1.28 kg) |

**Blank Covers**

| <b>PID (add = for spare)</b>                                                        | <b>Weight</b>     |
|-------------------------------------------------------------------------------------|-------------------|
| C9606-SLOT-BLANK<br>(Cisco Catalyst 9600 Series Blank for Chassis Module Slot)      | 2.87 lb (1.3 kg)  |
| C9606-PWR-BLANK<br>(Cisco Catalyst 9600 Series Blank for Chassis Power Supply Slot) | 0.18 lb (0.08 kg) |







# APPENDIX **B**

## LEDs

- Fan Tray LEDs, on page 101
- Power Supply Modules LEDs, on page 101
- Supervisor Module LEDs, on page 102
- Line Card LEDs, on page 103

### Fan Tray LEDs

| LED Type                                                                                      | LED Position or Color | Meaning                                                                                                                                                                                                                                                                                                                                                                                                             |
|-----------------------------------------------------------------------------------------------|-----------------------|---------------------------------------------------------------------------------------------------------------------------------------------------------------------------------------------------------------------------------------------------------------------------------------------------------------------------------------------------------------------------------------------------------------------|
| <br>STATUS | Off                   | Fan tray is not getting any power.                                                                                                                                                                                                                                                                                                                                                                                  |
|                                                                                               | Green                 | All fans are running and the fan tray is operating normally.                                                                                                                                                                                                                                                                                                                                                        |
|                                                                                               | Amber                 | One fan is not running.                                                                                                                                                                                                                                                                                                                                                                                             |
|                                                                                               | Red                   | Two or more fans are not running.                                                                                                                                                                                                                                                                                                                                                                                   |
| <br>LOCATE | Blue                  | <p>Identifies the fan tray receiving the beacon signal.</p> <p>The fan tray assembly has two blue beacon LEDs, one on the front panel and one on the rear. The two will always match each other.</p> <p>The blue beacon LED on the front panel is also a switch that you can press, to turn the front and rear blue beacons on or off. Alternatively, you can turn the blue beacons on or off through software.</p> |



### Power Supply Modules LEDs



| LED Position or Colour | Meaning                                                                                                                 |
|------------------------|-------------------------------------------------------------------------------------------------------------------------|
| Solid Green            | Indicates that the power supply module is switched on with outputs 12V main and 12Vstandby available and in regulation. |

| LED Position or Colour | Meaning                                                                                                                                                                                                                                                                                                                                                        |
|------------------------|----------------------------------------------------------------------------------------------------------------------------------------------------------------------------------------------------------------------------------------------------------------------------------------------------------------------------------------------------------------|
| Solid Amber            | Indicates one of the following: <ul style="list-style-type: none"> <li>• No output power available</li> <li>• AC/DC input is below the operating range</li> <li>• No 12V standby from a parallel unit is available</li> <li>• Over voltage/over current/over temperature conditions</li> <li>• Over-temperature protection (OTP) due to fan failure</li> </ul> |
| 1Hz Blinking Amber     | Indicates warning events such as a power supply module that continues to operate in high temperature or high power and a fan that runs slow and so on.                                                                                                                                                                                                         |
| 2Hz Blinking Green     | Indicates that power switch is turned off with AC/DC input power available or that the power supply is in standby mode.                                                                                                                                                                                                                                        |
| 1Hz Blinking Green     | Indicates bootloading mode.                                                                                                                                                                                                                                                                                                                                    |
| Off                    | Indicates one of the following: <ul style="list-style-type: none"> <li>• No input or output power available</li> <li>• AC/DC input is below the operating range</li> <li>• No 12V standby from a parallel unit</li> </ul>                                                                                                                                      |

## Supervisor Module LEDs



Table 13: LEDs and the Status

| LED type                                                                                           | LED Position or Colour | Meaning                                                                                             |
|----------------------------------------------------------------------------------------------------|------------------------|-----------------------------------------------------------------------------------------------------|
| <br>STATUS      | Green                  | Indicates that all diagnostic tests have passed after image booting.                                |
|                                                                                                    | Amber                  | Indicates a major environmental warning.                                                            |
|                                                                                                    | Red                    | Indicates a fault in the module due to parity error or failed diagnostic tests or hardware failure. |
|                                                                                                    | Off                    | Indicates that the supervisor module is disabled or is not powered up.                              |
| <br>BLUE BEACON | Solid blue             | Identifies the supervisor module receiving the beacon signal.                                       |

| LED type                                                                                    | LED Position or Colour | Meaning                                                                                                                                                                                                               |
|---------------------------------------------------------------------------------------------|------------------------|-----------------------------------------------------------------------------------------------------------------------------------------------------------------------------------------------------------------------|
| <br>SYSTEM | Green                  | Indicates that the environmental monitors are normal.                                                                                                                                                                 |
|                                                                                             | Amber                  | Indicates a minor fault such as partial power supply or fan failure.                                                                                                                                                  |
|                                                                                             | Red                    | Indicates a major fault. For example, situations where the temperature of the supervisor module exceeds the critical threshold.                                                                                       |
| <br>ACTIVE | Green                  | Indicates that the supervisor module is operational and is functioning as the active supervisor (in redundant supervisor module configurations).                                                                      |
|                                                                                             | Amber                  | Indicates one of the following: <ul style="list-style-type: none"> <li>• ROMMON mode</li> <li>• Supervisor module is functioning as the standby supervisor (in redundant supervisor module configurations)</li> </ul> |
|                                                                                             | Blinking Amber         | Indicates Graceful Insertion and Removal (GIR) of the module.                                                                                                                                                         |

## Line Card LEDs

Table 14: Line Card LEDs

| LED Type                                                                                           | LED Position or Colour | Meaning                                                                |
|----------------------------------------------------------------------------------------------------|------------------------|------------------------------------------------------------------------|
| <br>Blue Beacon | Blue                   | Module is receiving beacon signal.                                     |
| <br>Port Link   | Green                  | Port link is up, but there is no packet activity.                      |
|                                                                                                    | Blinking Green         | Port link is up, indicating packet activity.                           |
|                                                                                                    | Amber                  | Port link is disabled, that is, administratively down.                 |
|                                                                                                    | Off                    | No signal is detected, the link is down, or the port is not connected. |





# APPENDIX **C**

## Accessory Kit and Shelf Kit Contents

- [Standard Accessory Kit Contents, on page 105](#)
- [Shelf Kit Contents, on page 106](#)
- [23-Inch Rack Mount Kit Contents, on page 106](#)

### Standard Accessory Kit Contents

| Switch Model          | Standard Accessory Kit Part Number |
|-----------------------|------------------------------------|
| Catalyst 9606R Switch | C9606-ACC-KIT=                     |

Cisco Catalyst 9600 Series Switches ship with a standard accessory kit, which includes the following items:

| Item                                            | Quantity |
|-------------------------------------------------|----------|
| 12-24 x 0.75 inch M, Phillips screws            | 8        |
| 10-32 x 0.75 inch M, Phillips screws            | 8        |
| Adapter, DB9F/RJ45F                             | 1        |
| SFP module extractor                            | 1        |
| Disposable ESD wrist strap and clip termination | 1        |
| Grounding lug (no.10, with 2 holes), 6 AWG size | 1        |
| M4 x 8mm Phillips pan-head screws               | 2        |
| Fabricated plastic cable management guide       | 2        |
| Pointer Card                                    | 1        |

## Shelf Kit Contents



**Note** The shelf kit is not part of the standard accessory kit. You must order it separately by using the chassis-specific part number.

| Switch Model          | Shelf Kit Part Number |
|-----------------------|-----------------------|
| Catalyst 9606R Switch | C9606-SHELF-KIT=      |

The following table lists the contents of the shelf kit:

**Table 15: Shelf Kit Contents**

| Item and Description                                                                                | Quantity |
|-----------------------------------------------------------------------------------------------------|----------|
| Left L bracket.<br>Fabricated metal chassis L bracket, to secure the chassis to the rack enclosure. | 1        |
| Right L bracket.<br>Fabricated metal chassis L bracket, to secure the chassis to the rack enclosure | 1        |
| Shelf brackets<br>Fabricated metal, rack shelf brackets, to support the weight of the chassis.      | 2        |
| Shelf crossbar<br>Fabricated metal, rack shelf brackets crossbar, to fix the Shelf brackets.        | 1        |
| 12-24 x 0.75-inch Phillips screws                                                                   | 14       |
| 10-32 x 0.75-inch Phillips screws                                                                   | 14       |
| M4 x 5 mm Phillips flat head screws                                                                 | 10       |
| Documentation, pointer card<br>Provides references to related documentation on cisco.com            | 1        |

## 23-Inch Rack Mount Kit Contents



**Note** The 23-inch rack mount kit is not part of the standard accessory kit. You must order it separately by using the chassis-specific part number.

The 23-inch rack mount kit consists of the following items:

*Table 16: Contents of 23-Inch Rack Mount Kit*

| <b>Parts Description</b>                     | <b>Quantity</b> |
|----------------------------------------------|-----------------|
| Rack Mounts                                  | 2               |
| M4 Phillips pan-head screws                  | 6               |
| 12-24 x 3/4-inch Phillips binder-head screws | 6               |





THE SPECIFICATIONS AND INFORMATION REGARDING THE PRODUCTS IN THIS MANUAL ARE SUBJECT TO CHANGE WITHOUT NOTICE. ALL STATEMENTS, INFORMATION, AND RECOMMENDATIONS IN THIS MANUAL ARE BELIEVED TO BE ACCURATE BUT ARE PRESENTED WITHOUT WARRANTY OF ANY KIND, EXPRESS OR IMPLIED. USERS MUST TAKE FULL RESPONSIBILITY FOR THEIR APPLICATION OF ANY PRODUCTS.

THE SOFTWARE LICENSE AND LIMITED WARRANTY FOR THE ACCOMPANYING PRODUCT ARE SET FORTH IN THE INFORMATION PACKET THAT SHIPPED WITH THE PRODUCT AND ARE INCORPORATED HEREIN BY THIS REFERENCE. IF YOU ARE UNABLE TO LOCATE THE SOFTWARE LICENSE OR LIMITED WARRANTY, CONTACT YOUR CISCO REPRESENTATIVE FOR A COPY.

The following information is for FCC compliance of Class A devices: This equipment has been tested and found to comply with the limits for a Class A digital device, pursuant to part 15 of the FCC rules. These limits are designed to provide reasonable protection against harmful interference when the equipment is operated in a commercial environment. This equipment generates, uses, and can radiate radio-frequency energy and, if not installed and used in accordance with the instruction manual, may cause harmful interference to radio communications. Operation of this equipment in a residential area is likely to cause harmful interference, in which case users will be required to correct the interference at their own expense.

The following information is for FCC compliance of Class B devices: This equipment has been tested and found to comply with the limits for a Class B digital device, pursuant to part 15 of the FCC rules. These limits are designed to provide reasonable protection against harmful interference in a residential installation. This equipment generates, uses and can radiate radio frequency energy and, if not installed and used in accordance with the instructions, may cause harmful interference to radio communications. However, there is no guarantee that interference will not occur in a particular installation. If the equipment causes interference to radio or television reception, which can be determined by turning the equipment off and on, users are encouraged to try to correct the interference by using one or more of the following measures:

- Reorient or relocate the receiving antenna.
- Increase the separation between the equipment and receiver.
- Connect the equipment into an outlet on a circuit different from that to which the receiver is connected.
- Consult the dealer or an experienced radio/TV technician for help.

Modifications to this product not authorized by Cisco could void the FCC approval and negate your authority to operate the product.

The Cisco implementation of TCP header compression is an adaptation of a program developed by the University of California, Berkeley (UCB) as part of UCB's public domain version of the UNIX operating system. All rights reserved. Copyright © 1981, Regents of the University of California.

NOTWITHSTANDING ANY OTHER WARRANTY HEREIN, ALL DOCUMENT FILES AND SOFTWARE OF THESE SUPPLIERS ARE PROVIDED "AS IS" WITH ALL FAULTS. CISCO AND THE ABOVE-NAMED SUPPLIERS DISCLAIM ALL WARRANTIES, EXPRESSED OR IMPLIED, INCLUDING, WITHOUT LIMITATION, THOSE OF MERCHANTABILITY, FITNESS FOR A PARTICULAR PURPOSE AND NONINFRINGEMENT OR ARISING FROM A COURSE OF DEALING, USAGE, OR TRADE PRACTICE.

IN NO EVENT SHALL CISCO OR ITS SUPPLIERS BE LIABLE FOR ANY INDIRECT, SPECIAL, CONSEQUENTIAL, OR INCIDENTAL DAMAGES, INCLUDING, WITHOUT LIMITATION, LOST PROFITS OR LOSS OR DAMAGE TO DATA ARISING OUT OF THE USE OR INABILITY TO USE THIS MANUAL, EVEN IF CISCO OR ITS SUPPLIERS HAVE BEEN ADVISED OF THE POSSIBILITY OF SUCH DAMAGES.

Any Internet Protocol (IP) addresses and phone numbers used in this document are not intended to be actual addresses and phone numbers. Any examples, command display output, network topology diagrams, and other figures included in the document are shown for illustrative purposes only. Any use of actual IP addresses or phone numbers in illustrative content is unintentional and coincidental.

All printed copies and duplicate soft copies of this document are considered uncontrolled. See the current online version for the latest version.

Cisco has more than 200 offices worldwide. Addresses and phone numbers are listed on the Cisco website at [www.cisco.com/go/offices](http://www.cisco.com/go/offices).

Cisco and the Cisco logo are trademarks or registered trademarks of Cisco and/or its affiliates in the U.S. and other countries. To view a list of Cisco trademarks, go to this URL: [www.cisco.com/go/trademarks](http://www.cisco.com/go/trademarks). Third-party trademarks mentioned are the property of their respective owners. The use of the word partner does not imply a partnership relationship between Cisco and any other company. (1721R)

© 2019 Cisco Systems, Inc. All rights reserved.

