



<p><b>TEST REPORT</b> <b>IEC 62040-1</b> <b>Uninterruptible power systems (UPS) –</b> <b>Part 1: General and safety requirements for UPS</b></p>	
<b>Report Number</b> .....	ES170731050S
<b>Date of issue</b> .....	November 21, 2017
<b>Total number of pages</b> .....	89 pages
<b>Name of Testing Laboratory preparing the Report</b> .....	EMTEK (Shenzhen) Co., Ltd.
<b>Applicant's name</b> .....	INVT POWER SYSTEM(SHENZHEN) CO., LTD
<b>Address</b> .....	5th Floor, 1#Building, Gaofa Industrial Park, LongJing, Nanshan District, Shenzhen, China, 518055
<b>Test specification:</b>	
<b>Standard</b> .....	IEC 62040-1:2008 (First Edition) + Am 1: 2013
<b>Test procedure</b> .....	CB Scheme
<b>Non-standard test method</b> .....	N/A
<b>Test Report Form No.</b> .....	IEC62040_1D
<b>Test Report Form(s) Originator</b> .....	TÜV Rheinland Japan Ltd.
<b>Master TRF</b> .....	Dated 2016-08
<p><b>Copyright © 2016 IEC System of Conformity Assessment Schemes for Electrotechnical Equipment and Components (IECEE System). All rights reserved.</b></p> <p>This publication may be reproduced in whole or in part for non-commercial purposes as long as the IECEE is acknowledged as copyright owner and source of the material. IECEE takes no responsibility for and will not assume liability for damages resulting from the reader's interpretation of the reproduced material due to its placement and context.</p> <p>If this Test Report Form is used by non-IECEE members, the IECEE/IEC logo and the reference to the CB Scheme procedure shall be removed.</p> <p><b>This report is not valid as a CB Test Report unless signed by an approved CB Testing Laboratory and appended to a CB Test Certificate issued by an NCB in accordance with IECEE 02.</b></p>	
<b>General disclaimer:</b>	
<p>The test results presented in this report relate only to the object tested. This report shall not be reproduced, except in full, without the written approval of the Issuing CB Testing Laboratory. The authenticity of this Test Report and its contents can be verified by contacting the NCB, responsible for this Test Report.</p>	
<b>Test item description</b> .....	Uninterruptible Power System(UPS)
<b>Trade Mark</b> .....	INVT
<b>Manufacturer</b> .....	Same as applicant
<b>Model/Type reference</b> .....	HR33010CL, HR33015CL, HR33020CL, HR33025CL, HR31010CL, HR31015CL, HR31020CL
<b>Ratings</b> .....	See rating label



<b>Responsible Testing Laboratory (as applicable), testing procedure and testing location(s):</b>		
<input type="checkbox"/>	<b>CB Testing Laboratory:</b>	EMTEK (Shenzhen) Co., Ltd.
<b>Testing location/ address.....:</b>		Bldg 69, Majialong Industry Zone, Nanshan District, Shenzhen, Guangdong, China
<input type="checkbox"/>	<b>Associated CB Testing Laboratory:</b>	
<b>Testing location/ address.....:</b>		
<b>Tested by (name, function, signature).....:</b>		Gary Zhang / Engineer 
<b>Approved by (name, function, signature)....:</b>		William Guo / Manager 
<hr/>		
<input type="checkbox"/>	<b>Testing procedure: CTF Stage 1:</b>	
<b>Testing location/ address.....:</b>		
<b>Tested by (name, function, signature).....:</b>		
<b>Approved by (name, function, signature)....:</b>		
<hr/>		
<input type="checkbox"/>	<b>Testing procedure: CTF Stage 2:</b>	
<b>Testing location/ address.....:</b>		
<b>Tested by (name + signature) .....</b>		
<b>Witnessed by (name, function, signature) .:</b>		
<b>Approved by (name, function, signature)....:</b>		
<hr/>		
<input type="checkbox"/>	<b>Testing procedure: CTF Stage 3:</b>	
<input type="checkbox"/>	<b>Testing procedure: CTF Stage 4:</b>	
<b>Testing location/ address.....:</b>		
<b>Tested by (name, function, signature).....:</b>		
<b>Witnessed by (name, function, signature) .:</b>		
<b>Approved by (name, function, signature)....:</b>		
<b>Supervised by (name, function, signature) :</b>		

<p><b>List of Attachments (including a total number of pages in each attachment):</b></p> <ul style="list-style-type: none"> <li>- Attachment 1: National difference for IEC 62040-1:2008 (3 pages)</li> <li>- Photo document (18 pages)</li> </ul>	
<p><b>Summary of testing:</b></p>	
<p><b>Tests performed (name of test and test clause):</b></p> <ul style="list-style-type: none"> <li>• Tests performed on the bench</li> <li>• Maximum ambient temperature: +40°C</li> <li>• Tested for moderate conditions.</li> <li>• EUT is designed for altitudes not exceeding 2000m.</li> <li>• Installation category II is specified in installation manual for this product.</li> <li>• Pre-production sample without serial number.</li> <li>• Test on model: HR33025CL can represent other models. For model differences refer to page 6.</li> <li>• The EUTs pass the tests.</li> </ul>	<p><b>Testing location:</b> EMTEK (Shenzhen) Co., Ltd. Bldg 69, Majialong Industry Zone, Nanshan District, Shenzhen, Guangdong, China</p>
<p><b>Summary of compliance with National Differences (List of countries addressed):</b> <b>List of countries addressed: Group differences and national differences for CENELEC countries were checked.</b></p> <p><input checked="" type="checkbox"/> The product fulfils the requirements of EN 62040-1: 2008+A1: 2013.</p>	



**Copy of marking plate:**

The artwork below may be only a draft. The use of certification marks on a product must be authorized by the respective NCBs that own these marks.



1. Rating label for model HR33025CL:

	<b>HR33025CL</b>
<b>UPS</b>	<b>25kVA 3Ø+N</b>
<b>RETE 1 - MAINS 1 - NETZ 1</b>	<b>3Ø+N</b>
U <sub>in</sub> (Vac)	380/400/415
I <sub>in</sub> (A)	48*
Frequenza - Frequency - Frequenz	50÷60Hz
<b>RETE 2 - MAINS 2 - NETZ 2</b>	<b>3Ø+N</b>
U <sub>in</sub> (Vac)	380/400/415
I <sub>in</sub> (A)	--
Frequenza - Frequency - Frequenz	50÷60Hz
<b>USCITA - OUTPUT - AUSGANG</b>	<b>3Ø+N</b>
U <sub>out</sub> (Vac)	380/400/415
I <sub>out</sub> (A)	38*
Frequenza - Frequency - Frequenz	50÷60Hz
Potenza - Power rating - Leistung	25kVA/25kW (*:@380V)
<b>I<sub>cw</sub></b>	<b>6 kA</b>
<b>BATTERIA - BATTERY - BATTERIE</b>	
U <sub>dc</sub> (Vdc)	+/- 240
I <sub>dc</sub> (A)	57
<b>N° Serie - Serial Number - Seriennummer</b>	
<b>Year of construction</b>	<b>2017</b>
<b>5th Floor,1# Buiding,Gaofa Industrial Park, Longjing, Nanshan District, Shenzhen, China ,518055</b>	
 <b>Made in China</b>	 <b>30 kg</b>
<b>Service: <a href="http://www.invt-power.com">www.invt-power.com</a></b>	



2. Rating label for model HR33020CL:

	<b>HR33020CL</b>
<b>UPS</b>	<b>20kVA 3Ø+N</b>
<b>RETE 1 - MAINS 1 - NETZ 1</b>	<b>3Ø+N</b>
Uin (Vac)	380/400/415
Iin (A)	39*
Frequenza - Frequency - Frequenz	50÷60Hz
<b>RETE 2 - MAINS 2 - NETZ 2</b>	<b>3Ø+N</b>
Uin (Vac)	380/400/415
Iin (A)	--
Frequenza - Frequency - Frequenz	50÷60Hz
<b>USCITA - OUTPUT - AUSGANG</b>	<b>3Ø+N</b>
Uout (Vac)	380/400/415
Iout (A)	31*
Frequenza - Frequency - Frequenz	50÷60Hz
Potenza - Power rating - Leistung	20kVA/20kW (*:@380V)
<b>Icw</b>	<b>6 kA</b>
<b>BATTERIA - BATTERY - BATTERIE</b>	
Udc (Vdc)	+/- 240
Idc (A)	46
<b>N° Serie - Serial Number - Seriennummer</b>	
<b>Year of construction</b>	<b>2017</b>
<b>5th Floor,1# Buiding,Gaofa Industrial Park, Longjing, Nanshan District, Shenzhen, China ,518055</b>	
 <b>Made in China</b>	 <b>30 kg</b>
<b>Service: <a href="http://www.invt-power.com">www.invt-power.com</a></b>	



3. Rating label for model HR33015CL:

	<b>HR33015CL</b>
<b>UPS</b>	<b>15kVA 3Ø+N</b>
<b>RETE 1 - MAINS 1 - NETZ 1</b>	<b>3Ø+N</b>
U <sub>in</sub> (Vac)	380/400/415
I <sub>in</sub> (A)	30*
Frequenza - Frequency - Frequenz	50÷60Hz
<b>RETE 2 - MAINS 2 - NETZ 2</b>	<b>3Ø+N</b>
U <sub>in</sub> (Vac)	380/400/415
I <sub>in</sub> (A)	--
Frequenza - Frequency - Frequenz	50÷60Hz
<b>USCITA - OUTPUT - AUSGANG</b>	<b>3Ø+N</b>
U <sub>out</sub> (Vac)	380/400/415
I <sub>out</sub> (A)	23*
Frequenza - Frequency - Frequenz	50÷60Hz
Potenza - Power rating - Leistung	15kVA/15kW (*:@380V)
<b>I<sub>cw</sub></b>	<b>6 kA</b>
<b>BATTERIA - BATTERY - BATTERIE</b>	
U <sub>dc</sub> (Vdc)	+/- 240
I <sub>dc</sub> (A)	35
<b>N° Serie - Serial Number - Seriennummer</b>	
<b>Year of construction</b>	<b>2017</b>
<b>5th Floor,1# Buiding,Gaofa Industrial Park, Longjing, Nanshan District, Shenzhen, China ,518055</b>	
 <b>Made in China</b>	 <b>30 kg</b>
<b>Service: <a href="http://www.invt-power.com">www.invt-power.com</a></b>	

## 4. Rating label for model HR33010CL:



	<b>HR33010CL</b>
<b>UPS</b>	<b>10kVA 3Ø+N</b>
<b>RETE 1 - MAINS 1 - NETZ 1</b>	<b>3Ø+N</b>
U <sub>in</sub> (Vac)	380/400/415
I <sub>in</sub> (A)	20*
Frequenza - Frequency - Frequenz	50÷60Hz
<b>RETE 2 - MAINS 2 - NETZ 2</b>	<b>3Ø+N</b>
U <sub>in</sub> (Vac)	380/400/415
I <sub>in</sub> (A)	--
Frequenza - Frequency - Frequenz	50÷60Hz
<b>USCITA - OUTPUT - AUSGANG</b>	<b>3Ø+N</b>
U <sub>out</sub> (Vac)	380/400/415
I <sub>out</sub> (A)	16*
Frequenza - Frequency - Frequenz	50÷60Hz
Potenza - Power rating - Leistung	10kVA/10kW (*:@380V)
<b>I<sub>cw</sub></b>	<b>6 kA</b>
<b>BATTERIA - BATTERY - BATTERIE</b>	
U <sub>dc</sub> (Vdc)	+/- 240
I <sub>dc</sub> (A)	23
<b>N° Serie - Serial Number - Seriennummer</b>	
<b>Year of construction</b>	<b>2017</b>
<b>5th Floor,1# Buiding,Gaofa Industrial Park, Longjing, Nanshan District, Shenzhen, China ,518055</b>	
 <b>Made in China</b>	 <b>30 kg</b>
<b>Service: <a href="http://www.invt-power.com">www.invt-power.com</a></b>	

5. Rating label for model HR31020CL:



	<b>HR31020CL</b>
<b>UPS</b>	<b>20kVA 3Ø+N</b>
<b>RETE 1 - MAINS 1 - NETZ 1</b>	<b>3Ø+N</b>
U <sub>in</sub> (Vac)	380/400/415
I <sub>in</sub> (A)	39*
Frequenza - Frequency - Frequenz	50÷60Hz
<b>RETE 2 - MAINS 2 - NETZ 2</b>	<b>1Ø+N</b>
U <sub>in</sub> (Vac)	380/400/415
I <sub>in</sub> (A)	--
Frequenza - Frequency - Frequenz	50÷60Hz
<b>USCITA - OUTPUT - AUSGANG</b>	<b>1Ø+N</b>
U <sub>out</sub> (Vac)	380/400/415
I <sub>out</sub> (A)	91*
Frequenza - Frequency - Frequenz	50÷60Hz
Potenza - Power rating - Leistung	20kVA/20kW (*: @380V)
<b>I<sub>cw</sub></b>	<b>6 kA</b>
<b>BATTERIA - BATTERY - BATTERIE</b>	
U <sub>dc</sub> (Vdc)	+/- 240
I <sub>dc</sub> (A)	46
<b>N° Serie - Serial Number - Seriennumber</b>	
<b>Year of construction</b>	<b>2017</b>
<b>5th Floor,1# Buiding,Gaofa Industrial Park, Longjing, Nanshan District, Shenzhen, China ,518055</b>	
 <b>Made in China</b>	 <b>30 kg</b>
<b>Service: <a href="http://www.invt-power.com">www.invt-power.com</a></b>	



6. Rating label for model HR31015CL:

	<b>HR31015CL</b>
<b>UPS</b>	<b>15kVA 3Ø+N</b>
<b>RETE 1 - MAINS 1 - NETZ 1</b>	<b>3Ø+N</b>
Uin (Vac)	380/400/415
Iin (A)	30*
Frequenza - Frequency - Frequenz	50÷60Hz
<b>RETE 2 - MAINS 2 - NETZ 2</b>	<b>1Ø+N</b>
Uin (Vac)	380/400/415
Iin (A)	--
Frequenza - Frequency - Frequenz	50÷60Hz
<b>USCITA - OUTPUT - AUSGANG</b>	<b>1Ø+N</b>
Uout (Vac)	380/400/415
Iout (A)	69*
Frequenza - Frequency - Frequenz	50÷60Hz
Potenza - Power rating - Leistung	15kVA/15kW (*:@380V)
<b>Icw</b>	<b>6 kA</b>
<b>BATTERIA - BATTERY - BATTERIE</b>	
Udc (Vdc)	+/- 240
Idc (A)	35
<b>N° Serie - Serial Number - Seriennumber</b>	
<b>Year of construction</b>	<b>2017</b>
<b>5th Floor,1# Buiding,Gaofa Industrial Park, Longjing, Nanshan District, Shenzhen, China ,518055</b>	
 <b>Made in China</b>	 <b>30 kg</b>
<b>Service: <a href="http://www.invt-power.com">www.invt-power.com</a></b>	

7. Rating label for model HR31010CL:

	<b>HR31010CL</b>
<b>UPS</b>	<b>10kVA 3Ø+N</b>
<b>RETE 1 - MAINS 1 - NETZ 1</b>	<b>3Ø+N</b>
U <sub>in</sub> (Vac)	380/400/415
I <sub>in</sub> (A)	20*
Frequenza - Frequency - Frequenz	50÷60Hz
<b>RETE 2 - MAINS 2 - NETZ 2</b>	<b>1Ø+N</b>
U <sub>in</sub> (Vac)	380/400/415
I <sub>in</sub> (A)	--
Frequenza - Frequency - Frequenz	50÷60Hz
<b>USCITA - OUTPUT - AUSGANG</b>	<b>1Ø+N</b>
U <sub>out</sub> (Vac)	380/400/415
I <sub>out</sub> (A)	46*
Frequenza - Frequency - Frequenz	50÷60Hz
Potenza - Power rating - Leistung	10kVA/10kW (*: @380V)
<b>I<sub>cw</sub></b>	<b>6 kA</b>
<b>BATTERIA - BATTERY - BATTERIE</b>	
U <sub>dc</sub> (Vdc)	+/- 240
I <sub>dc</sub> (A)	23
<b>N° Serie - Serial Number - Seriennumber</b>	
<b>Year of construction</b>	<b>2017</b>
<b>5th Floor,1# Buiding,Gaofa Industrial Park, Longjing, Nanshan District, Shenzhen, China ,518055</b>	
 <b>Made in China</b>	 <b>30 kg</b>
<b>Service: <a href="http://www.invt-power.com">www.invt-power.com</a></b>	

8. Copy of Manufacturer and importer mark

Manufacturer: INVT POWER SYSTEM(SHENZHEN) CO., LTD  
Address: 5th Floor, 1#Building, Gaofa Industrial Park, LongJing,  
Nanshan District, Shenzhen, China, 518055  
Importer: xxx  
Address: xxx

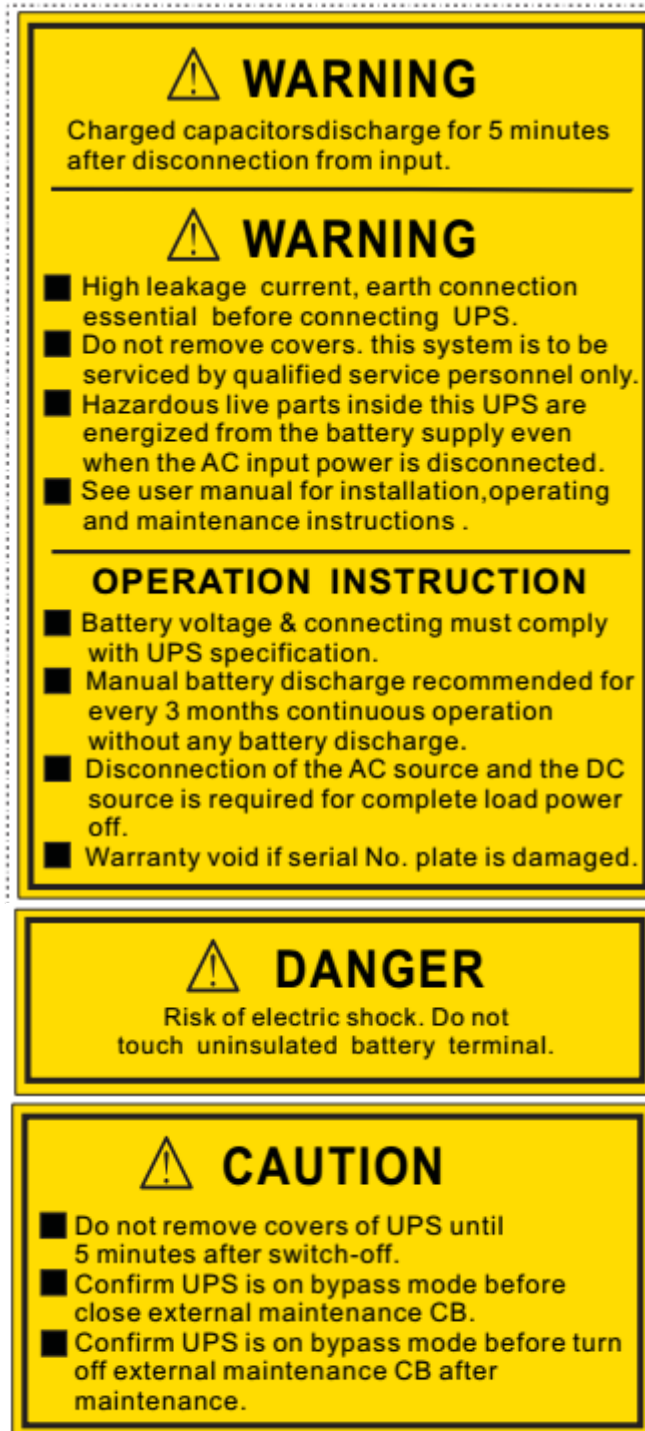

9. Warning label on outer enclosures



**Start-Up**  
 Step 1 : Switch On external Output CB.  
 Step 2 : Switch On external Bypass CB.  
 Step 3 : Switch On external Main CB.

**Shutdown**  
 Step 1 : Switch Off external Main CB.  
 Step 2 : Switch Off external Bypass CB.  
 Step 3 : Switch Off external Output CB.

**Maintenance**  
 Step 1: Transfer to Bypass manually (Form LCD panel).  
 Step 2: After load on static bypass, Turn On external Maintenance CB.  
 Step 3: Switch Off external Main CB, external Battery CB, external Bypass CB, external Output CB  
 Step 4: Doing Maintenance.  
 Step 5: After Maintenance, Switch On external Bypass CB, external Main CB, external Output CB  
 Step 6: After load on static bypass, Turn Off external Maintenance CB .

  **UPS Handling**

The UPS is very heavy.  
 It should be handled by 2 persons.  
 Please handle and lift the UPS  
 with proper method to prevent any  
 human injury or damage to the UPS.

  
**30kg**  
**>18kg**

Remark:

- The above markings are the minimum requirements required by the safety standard. For the final production samples, the additional markings which do not give rise to misunderstanding may be added.
- The CE marking and WEEE symbol should be at least 5.0 mm and 7.0 mm respectively in height.

<b>Test item particulars</b> .....	
<b>Classification of installation and use</b> .....	<input checked="" type="checkbox"/> User <input type="checkbox"/> Service Personal
<b>Supply Connection</b> .....	<input type="checkbox"/> pluggable equipment <input type="checkbox"/> type A <input type="checkbox"/> type B <input checked="" type="checkbox"/> permanent connection <input type="checkbox"/> detachable power supply cord <input type="checkbox"/> non-detachable power supply cord
<b>Equipment mobility</b> .....	<input type="checkbox"/> movable <input type="checkbox"/> transportable <input checked="" type="checkbox"/> stationary <input type="checkbox"/> for building-in
<b>Operation condition</b> .....	<input checked="" type="checkbox"/> continuous <input type="checkbox"/> rated operating / resting time:
<b>Access location</b> .....	<input checked="" type="checkbox"/> operator accessible <input type="checkbox"/> restricted access location
<b>Over voltage category (OVC)</b> .....	<input type="checkbox"/> OVC I <input checked="" type="checkbox"/> OVC II <input type="checkbox"/> OVC III <input type="checkbox"/> OVC IV
<b>Mains supply tolerance (%) or absolute mains supply values</b> .....	380/400/415Vac+10%,-15% (declared by client)
<b>Tested for IT power systems</b> .....	<input type="checkbox"/> Yes <input checked="" type="checkbox"/> No
<b>IT testing, phase-phase voltage (V)</b> .....	
<b>Class of equipment</b> .....	<input checked="" type="checkbox"/> Class I <input type="checkbox"/> Class II <input type="checkbox"/> Not classified
<b>Considered current rating of protective device as part of the building installation (A)</b> .....	16A
<b>Pollution degree (PD)</b> .....	<input type="checkbox"/> PD 1 <input checked="" type="checkbox"/> PD 2 <input type="checkbox"/> PD 3
<b>IP protection class</b> .....	IP20
<b>Elevation during operation (m)</b> .....	Up to 2000m
<b>Elevation of test laboratory (m)</b> .....	Below 2000m
<b>Mass of equipment (kg)</b> .....	30kg
<b>Possible test case verdicts:</b>	
- test case does not apply to the test object .....	: N/A
- test object does meet the requirement .....	: P (Pass)
- test object does not meet the requirement .....	: F (Fail)
<b>Testing</b> .....	
<b>Date of receipt of test item</b> .....	: October 10, 2017
<b>Date (s) of performance of tests</b> .....	: October 10, 2017 to October 24, 2017
<b>General remarks:</b>	
"(See Enclosure #)" refers to additional information appended to the report. "(See appended table)" refers to a table appended to the report.	
Throughout this report a <input type="checkbox"/> comma / <input checked="" type="checkbox"/> point is used as the decimal separator.	
<b>Manufacturer's Declaration per sub-clause 4.2.5 of IEC60060-2:</b>	

<p>The application for obtaining a CB Test Certificate includes more than one factory location and a declaration from the Manufacturer stating that the sample(s) submitted for evaluation is (are) representative of the products from each factory has been provided .....</p>	<p><input type="checkbox"/> <b>Yes</b> <input checked="" type="checkbox"/> <b>Not applicable</b></p>
<p><b>When differences exist; they shall be identified in the General product information section.</b></p>	
<p><b>Name and address of factory (ies) .....</b>: Same as applicant</p>	
<p><b>General product information:</b></p> <ol style="list-style-type: none"><li>1. The equipment models HR33025CL series are on line type uninterruptible power supplies with sine wave o/p for general use.</li><li>2. The input and output circuits and battery circuits of these UPS are considered as primary circuits and isolated from SELV circuit, RS232 port, SNP (optional) and parallel port by either double/reinforced insulation.</li><li>3. The enclosure consists of metal parts and thermoplastic front panel that is fixed to the metal chassis by screws. The front panel cannot be removed by operator/laymen without tools. Double/reinforced insulation provided where the primary LCD display (plastic cover with min. thickness of 0.4mm used) may be touched and basic insulation provided between primary parts and the reliably earthed metal. The front panel is considered as operator accessible area.</li><li>4. Suitable back feed protect device according to operating instruction should be provided before installation.</li><li>5. All models are designed with same control logic, constructions, PCB Layout except for the quantity of UPS module, model name and ratings. All tests were performed on model HR33025CL which means the typical model.</li></ol>	

IEC 62040-1			
Clause	Requirement + Test	Result - Remark	Verdict
<b>4</b>	<b>GENERAL CONDITIONS FOR TESTS</b>		<b>P</b>
<b>4.5</b>	<b>Components</b>		<b>P</b>
	Comply with IEC 62040-1 or relevant component standard	Components, which were found to affect safety aspects, comply with the requirements of this standard or within the safety aspects of the relevant IEC component standards. (see appended table 4.5)	P
1.5.2/RD	Evaluation and testing of components	Components, which are certified to IEC and/or national standards, are applied correctly within their ratings. Components not covered by IEC standards are tested under the conditions present in the equipment.	P
1.5.3/RD	Thermal controls	Thermal control not used	N/A
1.5.4/RD	Transformers	Transformers used are suitable for their intended application and comply with the relevant requirements of the standard and particularly Annex C.	P
1.5.5/RD	Interconnecting cables	Not provided.	N/A
1.5.6/RD	Capacitors bridging insulation	Capacitors between primary X2 type capacitor according to IEC 60384-14 used for bridging functional insulation.	P
1.5.7/RD	Resistors bridging insulation		P
1.5.7.1/RD	Resistors bridging functional, basic or supplementary insulation	Resistors only bridging functional insulation	P
1.5.7.2/RD	Resistors bridging double or reinforced insulation between a.c. mains and other circuits		N/A
1.5.7.3/RD	Resistors bridging double or reinforced insulation between a.c. mains and antenna or coaxial cable		N/A
1.5.8/RD	Components in equipment for IT power systems		N/A
<b>4.6</b>	<b>Power interface</b>		<b>P</b>
1.6.1/RD	AC power distribution systems	TN power system	P

IEC 62040-1			
Clause	Requirement + Test	Result - Remark	Verdict
1.6.2/RD	Input current	Highest normal load for this equipment is the charging of empty battery and operation with the maximum specified output load (see appended table 4.6)	P
4.6 1.6.4/RD	Neutral conductor	Basic insulation for rated voltage between earthed parts and line and neutral conductors.  O/p neutral is not isolated from the I/p neutral.	P
<b>4.7</b>	<b>Marking and instructions</b>		<b>P</b>
4.7.1	General		P
4.7.2 1.7.1/RD	Power rating	All required markings are affixed on labels located on the enclosure of UPS	P
	Input rated voltage/range (V) .....	See rating label for details	P
	Input rated current/range (A).....	See rating label for details	P
	Input symbol for nature of supply (d.c.).....	See rating label for details	N/A
	Input rated frequency/range (Hz).....	50/60 Hz	P
	Number of Input phases and neutral .....	Three phase, 3Ø+N+PE	P
	Output rated voltage/range (V) .....	See rating label for details	P
	Output rated current/range (A).....	See rating label for details	P
	Output rated power factor, if less than unity, or active power and apparent power or active power and rated current.....	The active power and apparent power are marked on rating label.	P
	Number of output phases and neutral .....	Three phase, 3Ø+N+PE	P
	Output rated active power (W or kW).....	See rating label for details	P
	Output rated apparent power (VA or kVA) .....	See rating label for details	P
	Output symbol for nature of supply (d.c.).....	AC outlet provided.	N/A
	Output rated frequency/range (Hz).....	50/60Hz	P
	Ambient operating temperature range (°C).....	Not shown (0-40°C declared by the client)	N/A
	Rated short-time withstand current ( $I_{cw}$ ) or rated conditional short-circuit current ( $I_{cc}$ )	$I_{cw}$ : 6kA	P
	Manufacturer's name or trademark or identification mark .....	See page 1 for details	P
	Type/model or type reference .....	See page 1 for details	P
	Symbol for Class II equipment only .....	Class I equipment	N/A



IEC 62040-1			
Clause	Requirement + Test	Result - Remark	Verdict
	Other symbols .....	Additional symbols or markings do not give rise to misunderstanding.	P
	Certification marks .....	To be evaluated when subjected to national approval	P
	Instructions for units with automatic bypass/maintenance bypass, additional input a.c. supply, or external batteries, having text "See installation instructions before connecting to the supply" .....	Instruction provided. See copy of marking plate	P
4.7.3	Safety instructions	See below	P
4.7.3.1	General	"User manual" with directions regarding the maximum ambient temperature, electrical ratings, operation, description of interfaces, connection to the mains. Service personnel installable and to be operated by laymen. Appropriate statements provided in the "User Manual".	P
4.7.3.2	Installation .....	Installation instructions are available to the user in User's Manual.	P
	Location in a restricted access location only .....		N/A
	Permanent connector UPS .....	Installation person and disconnect device instructions are available to the user in User's Manual.	N/A
	Pluggable type A or Pluggable type B UPS .....	See above	P
4.7.3.3	Operation .....	The suitable information list in the user manual when operate the UPS.	P
4.7.3.4	Maintenance .....	The instruction of maintenance is only included in the service manual.	P
4.7.3.5	Distribution related backfeed .....		N/A
4.7.4 1.7.4/RD	Main voltage adjustment .....	Single input voltage range	N/A
	Methods and means of adjustment; reference to installation instructions .....		N/A
4.7.5 1.7.5/RD	Power outlets .....	No power outlets used in the equipment.	N/A

IEC 62040-1			
Clause	Requirement + Test	Result - Remark	Verdict
4.7.6 1.7.6/RD	Fuse identification (marking, special fusing characteristics, cross-reference)..... :	All fuses and circuit breakers are not located in operator accessible area. Fuse rating placed on the relevant PCB layout and metal enclosure which is nearby the fuse body. Fuse identifications for internal use and other detailed information.	P
4.7.7 1.7.7/RD	Wiring terminals	See below	P
1.7.7.1/RD	Protective earthing and bonding terminals..... :	Only PE of "Normal AC supply" with symbol 60417-1-IEC-5019, others with symbol 60417-1-IEC-5017.	P
1.7.7.2/RD	Terminals for a.c. mains supply conductors ..... :	Terminals provided. Capital letters L1, L2, L3 and N are used to identify input and output phase.	P
1.7.7.3/RD	Terminals for d.c. mains supply conductors ..... :		P
4.7.8	Battery terminals ..... :	Symbol "+" and "-" are used to indicate the polarity of battery connection near the battery terminals.	P
4.7.9 1.7.8/RD	Controls and indicators	See below	P
1.7.8.1/RD	Identification, location and marking ..... :	LCD display provided, located on the front panel to indicate status of UPS, not relevant to safety.	P
1.7.8.2/RD	Colours ..... :	See above. Colours are acceptable due to only used for information (no safety involved even if disregarded).	P
1.7.8.3/RD	Symbols..... :		N/A
1.7.8.4/RD	Markings using figures..... :	Not used.	N/A
4.7.10 1.7.9/RD	Isolation of multiple power sources ..... :	Different connecting method for AC mains and external battery cabinet used, not likely to misconnect. Disconnecting all input (mains connection and battery input) is specified in caution label and user manual	P
4.7.11 1.7.2.4/RD	IT power systems		N/A

IEC 62040-1			
Clause	Requirement + Test	Result - Remark	Verdict
4.7.12	Protection in building installation	Protection against electric shock does not rely on residual current devices.	P
	Rated short-time withstand current ( <i>I<sub>cw</sub></i> ) .....	<i>I<sub>cw</sub></i> : 6kA	P
	Rated conditional short circuit current ( <i>I<sub>cc</sub></i> ) .....		N/A
	a) If higher <i>I<sub>cp</sub></i> stated ≤ 10 kA	<i>I<sub>cw</sub></i> : 6kA	P
	a) If higher <i>I<sub>cp</sub></i> stated > 10 kA		N/A
4.7.13 5.1/RD	High leakage current (mA) .....	Leakage current of the equipment does not exceed 3.5 mA.  However due to the connected load has influence on the overall earth leakage current a corresponding statement was provided in the user's manual.	N/A
4.7.14 1.7.10/RD	Thermostats and other regulating devices	Neither thermostats nor other regulating devices provided.	N/A
4.7.15 1.7.2.1/RD and 1.7.8.1/RD	Language(s) .....	User Manual and markings are both in English.  Local language versions will be made available during national approval.	—
4.7.16 1.7.11/RD	Durability of markings	The label was subjected to the permanence of marking test. The label was rubbed with cloth soaked with water for 15 s and then again for 15 s with the cloth soaked with petroleum spirit. After this test there was no damage to the label. The marking on the label did not fade. There was neither curling nor lifting of the label edge.	P
4.7.17 1.7.12/RD	Removable parts	No required markings placed on removable parts.	P
4.7.18 1.7.13/RD	Replaceable batteries	Warning label used	P
	Language(s) .....		—
4.7.19 1.7.2.5/RD	Operator access with a tool.....	Operator is not instructed to use a tool in order to gain access to operator access areas.	N/A

IEC 62040-1			
Clause	Requirement + Test	Result - Remark	Verdict
4.7.20	Battery	UPS's batteries will be located in the external battery cabinet. Specific requirements stated in installation manual.	P
	Clearly legible information..... :	Information clearly legible.	P
	Battery type (lead-acid, NiCd, etc.) and number of blocks or cells..... :	Detailed information regarding to the battery used will be provided in the instruction manual.	P
	Nominal voltage of total battery (V)..... :	240Vdc	P
	Nominal capacity of total battery (optional)..... :		N/A
	Warning label..... :	Considered	P
	Instructions..... :	Instructions of the UPS with information: <ul style="list-style-type: none"> <li>• Maintenance and disposal instructions</li> <li>• "Caution" statements regarding battery hazards</li> <li>• Remark that servicing shall be performed by personnel knowledgeable of batteries</li> </ul>	P
2.1.1.5/RD	Protection against energy hazards	No risk of energy hazard in operator access area. Hazardous area restricted with metal plate	P
4.7.21 1.7.2.4/RD	Installation instructions	Detailed information regarding external interfaces and connection of supply and loads provided in the user's manual	P

<b>5</b>	<b>FUNDAMENTAL DESIGN REQUIREMENTS</b>		<b>P</b>
<b>5.1</b>	<b>Protection against electric shock and energy hazards</b>		<b>P</b>
5.1.1 2.1.1/RD	Protection for UPS intended to be used in operator access areas	No hazardous voltage circuit wiring can be accessed by operator.	P
2.1.1.1/RD	Access to energized parts	No hazardous voltage circuit wiring can be accessed by operator.	P
	Test by inspection..... :		P

IEC 62040-1			
Clause	Requirement + Test	Result - Remark	Verdict
	Test with test finger (Figure 2A)..... :	The test pin can not touch hazardous voltage through any seams within the appliance.	P
	Test with test pin (Figure 2B)..... :	The test probe cannot touch contacts of LINE port.	P
	Test with test probe (Figure 2C)..... :		N/A
2.1.1.2/RD	Battery compartments	No TNV circuits exist inside battery compartments	N/A
2.1.1.3/RD	Access to ELV wiring	No ELV wiring in operator accessible area.	N/A
	Working voltage ( $V_{peak}$ or $V_{rms}$ ); minimum distance through insulation (mm)		—
2.1.1.4/RD	Access to hazardous voltage circuit wiring	No any hazardous voltage circuit wiring operator accessible.	P
2.1.1.5/RD	Energy hazards..... :	No energy hazard at operator accessible area. No energy hazard during battery replacement for service person due to shape of battery terminals.	P
2.1.1.6/RD	Manual controls	No conductive controls or handles or alike provided.	N/A
2.1.1.7/RD	Discharge of capacitors in equipment		P
	Measured voltage (V); time-constant (s)..... :	(See appended table 5.1.1 and 2.1.1.7/RD)	—
2.1.1.8/RD	Energy hazards – d.c. mains supply		N/A
	a) Capacitor connected to the d.c. mains supply ... :		N/A
	b) Internal battery connected to the d.c. mains supply ..... :		N/A
2.1.1.9/RD	Audio amplifiers in information technology equipment..... :		N/A
5.1.2 2.1.1.5 c) /RD	Protection for UPS intended to be used in service access areas		N/A
	Hazardous energy level..... :		N/A
5.1.3 2.1.1.5 c) /RD	Protection for UPS intended to be used in restricted access areas		N/A
	Hazardous energy level..... :		N/A

IEC 62040-1			
Clause	Requirement + Test	Result - Remark	Verdict
5.1.4	Backfeed protection	Backfeed protection such as contactor will be provided external to the UPS in the final installation which is also specified in installation manual	N/A
	Shock hazard after de-energization of a.c. input for UPS		N/A
	Measured voltage (V); time-constant (s)..... :		—
	Description of the construction .....		N/A
	Air gap is employed for backfeed protection		N/A
5.1.5	Emergency switching (disconnect) device	REPO dry contactor provided, which is used to shut down the UPS in case of emergency.	P
<b>5.2</b>	<b>Requirements for auxiliary circuits</b>		P
5.2.1 2.2/RD	Safety extra low voltage circuit - SELV	EPO, USB and RS232 port is considered as SELV circuit	P
2.2.1/RD	General requirements	All SELV circuits within limits.	P
2.2.2/RD	Voltages under normal conditions (V) .....	(See appended table 5.2.1)	P
2.2.3/RD	Voltages under fault conditions (V) .....	(See appended table 5.2.1)	P
2.2.4/RD	Connection of SELV circuits to other circuits..... :	To SELV only	P
5.2.2 2.3/RD	Telephone network voltage circuits - TNV	No TNV circuit.	N/A
2.3.1/RD	Limits		N/A
	Type of TNV circuits .....		—
2.3.2/RD	Separation of TNV circuits from other circuits and from accessible parts		N/A
2.3.2.1/RD	General requirements		N/A
2.3.2.2/RD	Protection by basic insulation		N/A
2.3.2.3/RD	Protection by earthing		N/A
2.3.2.4/RD	Protection by other constructions .....		N/A
2.3.3/RD	Separation from hazardous voltages		N/A
	Insulation employed..... :		—
2.3.4/RD	Connection of TNV circuits to other circuits		N/A
	Insulation employed..... :		—
2.3.5/RD	Test for operating voltages generated externally		N/A
5.2.3 2.4/RD	Limited current circuits		N/A
2.4.1/RD	General requirements		N/A

IEC 62040-1			
Clause	Requirement + Test	Result - Remark	Verdict
2.4.2/RD	Limit values		—
	Frequency (Hz) .....		—
	Measured current (mA) .....		—
	Measured voltage (V) .....		—
	Measured circuit capacitance (nF or $\mu$ F) .....		—
2.4.3/RD	Connection of limited current circuits to other circuits		N/A
5.2.4 3.5/RD	External signaling circuits	EPO, USB and RS232 port is considered as SELV circuit	P
3.5.1/RD	General requirements		P
3.5.2/RD	Types of interconnection circuits .....	See above.	P
3.5.3/RD	ELV circuits as interconnection circuits		N/A
3.5.4/RD	Data ports for additional equipment	See above.	N/A
5.2.5 2.5/RD	Limited power source		N/A
	a) Inherently limited output		N/A
	b) Impedance limited output		N/A
	c) Regulating network limited output under normal operating and single fault condition		N/A
	d) Overcurrent protective device limited output		N/A
	Max. output voltage (V), max. output current (A), max. apparent power (VA) .....		—
	Current rating of overcurrent protective device (A) :		—
	Use of integrated circuit (IC) current limiters		—
<b>5.3</b>	<b>Protective earthing and bonding</b>		<b>P</b>
5.3.1	General		P
2.6/RD	Provisions for earthing and bonding	See below	P
2.6.1/RD	Protective earthing	Reliable connection from the protective bonding terminal on outlet to the PE terminal (AC plug) via green/yellow insulated wires.	P
2.6.2/RD	Functional earthing		N/A
2.6.3/RD	Protective earthing conductors and protective bonding conductors	See below	P
2.6.3.1/RD	General	See subclause 2.6.3.3/RD	P

IEC 62040-1			
Clause	Requirement + Test	Result - Remark	Verdict
2.6.3.2/RD	Size of protective earthing conductors	Permanent connection. For input terminals, the size of protective earthing conductor shall be selected according to installation manual.	P
	Rated current (A), cross-sectional area (mm <sup>2</sup> ), AWG .....		—
2.6.3.3/RD	Size of protective bonding conductors	UPS metal frame works as protective bonding conductor, is considered to be sufficient (comply with table 3B of 3.2.5/RD) for the current under earth fault.	P
	Rated current (A), cross-sectional area (mm <sup>2</sup> ), AWG .....		—
	Protective current rating (A), cross-sectional area (mm <sup>2</sup> ), AWG .....		—
2.6.3.4/RD	Resistance of earthing conductors and their terminations; resistance ( $\Omega$ ), voltage drop (V), test current (A), duration (min) .....	(See appended table 5.3.1)	P
2.6.3.5/RD	Colour of insulation .....	Green/yellow	P
2.6.4/RD	Terminals	See above	P
2.6.4.1/RD	General		P
2.6.4.2/RD	Protective earthing and bonding terminals	See instruction manual for the details configuration	P
	Rated current (A), type, nominal thread diameter (mm).....		—
2.6.4.3/RD	Separation of the protective earthing conductor from protective bonding conductors	Protective bonding conductor is used form the input terminal to the metal chassis, separate bonding terminal used to connect the bonding conductor between different output terminals and metal frame of the UPS.	P
2.6.5/RD	Integrity of protective earthing	See below	P
2.6.5.1/RD	Interconnection of equipment	This unit has it's own earthing connection. PE terminals of outlets reliably connected to earthing pin of inlet.	P
2.6.5.2/RD	Components in protective earthing conductors and protective bonding conductors	No switch or overcurrent protective device in protective bonding conductors.	P
2.6.5.3/RD	Disconnection of protective earth	Permanently equipment no disconnection.	P



IEC 62040-1			
Clause	Requirement + Test	Result - Remark	Verdict
2.6.5.4/RD	Parts that can be removed by an operator	Permanent connection, no parts can be removed by operator.	N/A
2.6.5.5/RD	Parts removed during servicing	It is not necessary to disconnect earthing except for the removal of the earthed part itself.	P
2.6.5.6/RD	Corrosion resistance	All safety earthing connections in compliance with Annex J.	P
2.6.5.7/RD	Screws for protective bonding	Protective bonding conductors connected to metal chassis via ring-type lugs fixed to metal studs (ISO thread type M10, with nut and star-washer provided)	P
2.6.5.8/RD	Reliance on telecommunication network or cable distribution system		N/A
5.3.2 2.6.1/RD	Protective earthing	See 2.6.3/RD and 2.6.4/RD.	P
2.10/RD	Clearances, creepage distances and distances through insulation	(see appended table 5.7)	P
4.2/RD	Mechanical strength		P
5.2/RD	Electric strength	(see appended table 8.2)	P
5.3.3	Protective bonding	See above	P
<b>5.4</b>	<b>AC and d.c. power isolation</b>		<b>P</b>
5.4.1	General		P
3.4/RD	Disconnection from the mains supply		P
3.4.1/RD	General requirement		P
3.4.2/RD	Disconnect devices	For permanent connection type, according to installation instruction, suitable circuit breaker external to the UPS will be installed as disconnect device.	P
3.4.3/RD	Permanently connected equipment	External disconnect should be provide.	P
3.4.4/RD	Parts which remain energized	Adequate protection provided to service personnel during backup mode.	P
3.4.5/RD	Switches in flexible cords	None provided.	N/A
3.4.6/RD	Number of poles - single-phase and d.c. equipment	Three phase equipment	P

IEC 62040-1			
Clause	Requirement + Test	Result - Remark	Verdict
3.4.7/RD	Number of poles - three-phase equipment	3 pole switch will be used as disconnected device for whole system and it is optional to the UPS, Adequate disconnection information regarding the disconnection switch for the configuration without the integrated disconnection switch for whole unit was already stated in the final installation	P
3.4.8/RD	Switches as disconnect devices	Relevant indication provided on the body of disconnection switch	P
3.4.9/RD	Plugs as disconnect devices		N/A
3.4.10/RD	Interconnected equipment	Hazardous Voltage circuits to Hazardous circuits.	P
3.4.11/RD	Multiple power sources	Instructions provided at every switch, see "Copies of markings and warnings".	P
5.4.2	Disconnect devices		P
<b>5.5</b>	<b>Overcurrent and earth fault protection</b>		<b>P</b>
5.5.1	General		P
2.7.3/RD	Short-circuit backup protection	Over current protection by built-in fuses in each of 3 phases. Permanently Connected Equipment. Building Installation is provide short-circuit backup protection.	P
2.7.4/RD	Number and location of protective devices..... :	Over current protector provided in live conductor	P
2.7.5/RD	Protection by several devices	Three fuse in parallel protection device provided. No protective device in neutral.	P
2.7.6/RD	Warning to service personnel ..... :	No double-pole fusing inside this pluggable equipment type A UPS.	N/A
5.5.2	Basic requirements	Equipment relies on fuse or circuit breaker of the wall outlet protection of the building installation in regard to L to N short-circuit. Over current protection is provided by the built-in fuse.	P

IEC 62040-1			
Clause	Requirement + Test	Result - Remark	Verdict
5.5.3	Battery circuit protection	External battery cabinet is not provided with UPS. Protection shall be provided in battery cabinet.	P
5.5.3.1	Overcurrent and earth fault protection	Battery fuses are directly located behind the supply wire terminals to the external battery cabinets  The charger circuit is located in front of the fuse. For the charger circuit there are no hazardous situations under any simulated fault conditions. (see appended table 8.3).	P
5.5.3.2	Location of protective device	See above.	P
5.5.3.3	Rating of protective device	Protection against overcurrent by Fuse.	P
5.3.1/RD	Protection against overload and abnormal operation	(see appended table 8.3)	P
5.5.4	Short-time withstand current	I <sub>cw</sub> : 6kA	N/A
5.5.4.1	General		N/A
5.5.4.2	Modes of operation		N/A
5.5.4.3	Test procedure		N/A
5.5.4.3.1	General application		N/A
	Rated UPS output current/(r.m.s) (A)..... :		—
	Prospective test current/(r.m.s) (A)..... :		—
	Typical power factor .....		—
	Initial asymmetric peak current ration (I <sub>pk</sub> / I <sub>cw</sub> ).... :		—
	Minimum duration of prospective test current (cycles 50/60 Hz) .....		—
5.5.4.3.2	Exemption from testing	Specified I <sub>cc</sub> / I <sub>cw</sub> not exceed 10kA, no test necessary.	P
<b>5.6</b>	<b>Protection of personnel – Safety interlocks</b>		<b>P</b>
5.6.1	Operator protection	No hazardous voltage levels in operator accessible areas.	P
2.8/RD	General principles		N/A
2.8.1/RD	Protection requirements		N/A
2.8.2/RD	Inadvertent reactivation		N/A
2.8.3/RD	Fail-safe operation		N/A
2.8.4/RD	Protection against extreme hazard		N/A
2.8.5/RD	Moving parts		N/A

IEC 62040-1			
Clause	Requirement + Test	Result - Remark	Verdict
2.8.6/RD	Overriding		N/A
2.8.7/RD	Switches, relays and their related circuits		N/A
2.8.7.1/RD	Separation distances for contact gaps and their related circuits .....		N/A
2.8.7.2/RD	Overload test		N/A
2.8.7.3/RD	Endurance test		N/A
2.8.7.4/RD	Electric strength test	(see appended table 8.2)	N/A
2.8.8/RD	Mechanical actuators		N/A
5.6.2	Service person protection		N/A
5.6.2.1	Introduction		N/A
5.6.2.2	Covers		N/A
5.6.2.3	Location and guarding of parts		N/A
5.6.2.4	Parts on doors		N/A
5.6.2.5	Component access		N/A
2.8.3/RD	Fail-safe operation		N/A
5.6.2.6	Moving parts		N/A
5.6.2.7	Capacitor banks		N/A
5.6.2.8	Internal batteries	Risk of short-circuiting minimized by design of used battery source and corresponding terminals and wiring methods used.	P
<b>5.7 2.10/RD</b>	<b>Clearances, creepage distances and distances through insulation</b>		P
2.10.1/RD	General	See 2.10.3, 2.10.4 and 2.10.5.	P
2.10.1.1/RD	Frequency.....	Considered	P
2.10.1.2/RD	Pollution degrees .....	2	P
2.10.1.3/RD	Reduced values for functional insulation	See 5.3.4.	N/A
2.10.1.4/RD	Intervening unconnected conductive parts	No such part.	N/A
2.10.1.5/RD	Insulation with varying dimensions	No such transformer used.	N/A
2.10.1.6/RD	Special separation requirements		P
2.10.1.7/RD	Insulation in circuits generating starting pulses	No such circuit.	N/A
2.10.2/RD	Determination of working voltage		P

IEC 62040-1			
Clause	Requirement + Test	Result - Remark	Verdict
2.10.2.1/R D	General	The rms and the peak voltage were measured with unit connected to a 240V/415V(Three phase) TN power system. Pollution Degree 2 and Overvoltage Category II considered.	P
2.10.2.2/R D	RMS working voltage	(See appended table 5.7)	P
2.10.2.3/R D	Peak working voltage	(See appended table 5.7)	P
2.10.3/RD	Clearances	See below and advantage of annex G is not considered.	P
2.10.3.1/R D	General	Considered.	P
2.10.3.2/R D	Mains transient voltages		P
	a) AC mains supply..... :	240V a.c. and Overvoltage Category II	P
	b) Earthed d.c. mains supplies ..... :		N/A
	c) Unearthed d.c. mains supplies ..... :		N/A
	d) Battery operation ..... :		N/A
2.10.3.3/R D	Clearances in primary circuits	(see appended table 5.7)	P
2.10.3.4/R D	Clearances in secondary circuits	Sub-clause 5.3.4 considered.	P
2.10.3.5/R D	Clearances in circuits having starting pulses		N/A
2.10.3.6/R D	Transients from a.c. mains supply..... :	Normal transient voltage considered (overvoltage category II for primary circuit).	P
2.10.3.7/R D	Transients from d.c. mains supply..... :		N/A
2.10.3.8/R D	Transients from telecommunication networks and cable distribution systems..... :		N/A
2.10.3.9/R D	Measurement of transient voltage levels		N/A
	a) Transients from a mains supply		N/A
	For an a.c. mains supply ..... :		N/A
	For a d.c. mains supply ..... :		N/A
	b) Transients from a telecommunication network... :		N/A

IEC 62040-1			
Clause	Requirement + Test	Result - Remark	Verdict
2.10.4/RD	Creepage distances	(see appended table 5.7)	P
2.10.4.1/RD	General		P
2.10.4.2/RD	Material group and comparative tracking index		P
	CTI tests .....	Material group IIIb is assumed to be used.	P
2.10.4.3/RD	Minimum creepage distances	(see appended table 5.7)	P
2.10.5 /RD	Solid insulation		P
2.10.5.1/RD	General	See below	P
2.10.5.2/RD	Distances through insulation	(see appended table 5.7)	P
2.10.5.3/RD	Insulating compound as solid insulation		N/A
2.10.5.4/RD	Semiconductor devices	Approved optocoupler used.	P
2.10.5.5/RD	Cemented joints	No such construction.	N/A
2.10.5.6/RD	Thin sheet material – General	Ref. to sub-clause 2.10.5.1/RD and Annex C	P
2.10.5.7/RD	Separable thin sheet material		P
	Number of layers (pcs) .....		—
2.10.5.8/RD	Non-separable thin sheet material		N/A
2.10.5.9/RD	Thin sheet material – standard test procedure		N/A
	Electric strength test		—
2.10.5.10 /RD	Thin sheet material – alternative test procedure		P
	Electric strength test	(See appended table 5.8)	—
2.10.5.11 /RD	Insulation in wound components		N/A
2.10.5.12 /RD	Wire in wound components	No wound components used.	N/A
	Working voltage .....		—
	a) Basic insulation not under stress .....		N/A
	b) Basic, supplementary, reinforced insulation.....		N/A
	c) Compliance with Annex U .....		N/A

IEC 62040-1			
Clause	Requirement + Test	Result - Remark	Verdict
	Two wires in contact inside wound component; angle between 45° and 90° .....		N/A
2.10.5.13 /RD	Wire with solvent-based enamel in wound components	No such construction.	N/A
	Electric strength test		—
	Routine test		N/A
2.10.5.14 /RD	Additional insulation in wound components	No such construction.	N/A
	Working voltage .....		—
	- Basic insulation not under stress.....		N/A
	- Supplementary, reinforced insulation.....		N/A
2.10.6/RD	Construction of printed boards	See below	P
2.10.6.1/RD	Uncoated printed boards	(See appended table 5.7)	P
2.10.6.2/RD	Coated printed boards	No coated printed boards.	N/A
2.10.6.3/RD	Insulation between conductors on the same inner surface of a printed board	No multi-layer PCBs provided.	N/A
2.10.6.4/RD	Insulation between conductors on different layers of a printed board	No multi-layer PCBs provided.	N/A
	Distance through insulation		N/A
	Number of insulation layers (pcs) .....	Single layer PCB	N/A
2.10.7/RD	Component external terminations	(See appended table 5.7)	P
2.10.8/RD	Tests on coated printed boards and coated components	No such boards and components	N/A
2.10.8.1/RD	Sample preparation and preliminary inspection		N/A
2.10.8.2/RD	Thermal conditioning		N/A
2.10.8.3/RD	Electric strength test	(see appended table 8.2)	—
2.10.8.4/RD	Abrasion resistance test		N/A
2.10.9/RD	Thermal cycling		N/A
2.10.10/RD	Test for Pollution Degree 1 environment and insulating compound		N/A
2.10.11/RD	Tests for semiconductor devices and cemented joints	See only 2.10.5.4/RD regards approved optocouplers	N/A
2.10.12/RD	Enclosed and sealed parts	No hermetically sealed component.	N/A

IEC 62040-1			
Clause	Requirement + Test	Result - Remark	Verdict
<b>6</b>	<b>Wiring, connections and supply</b>		<b>P</b>
<b>6.1</b>	<b>General</b>		<b>P</b>
6.1.1	Introduction		<b>P</b>
3.1/RD	General		<b>P</b>
3.1.1/RD	Current rating and overcurrent protection	Internal wires are UL recognized wiring which is PVC insulated, rated VW-1 or FT-1, and having gauge suitable for current intended to be carried.	<b>P</b>
3.1.2/RD	Protection against mechanical damage	Wires do not touch sharp edges which could damage the insulation and cause hazard.	<b>P</b>
3.1.3/RD	Securing of internal wiring	Internal wires are secured by solder pins, cable ties and quick connect terminals so that a loosening of the terminal connection is unlikely.	<b>P</b>
3.1.4/RD	Insulation of conductors	The insulation of the individual conductors is suitable for the application and the working voltage. For the insulation material see subclause 3.1.1/RD.	<b>P</b>
3.1.5/RD	Beads and ceramic insulators	Not used.	<b>N/A</b>
3.1.6/RD	Screws for electrical contact pressure	No such screws provided.	<b>N/A</b>
3.1.7/RD	Insulating materials in electrical connections	All current carrying connections are metal to metal.	<b>P</b>
3.1.8/RD	Self-tapping and spaced thread screws	Not used.	<b>N/A</b>
3.1.9/RD	Termination of conductors	All conductors are reliable secured.	<b>P</b>
	10 N pull test	Force of 10 N applied to the termination points of the conductors.	<b>P</b>
3.1.10/RD	Sleeving on wiring	Heat shrinkable tube used on the wire connector point.	<b>P</b>
6.1.2	Dimensions and rating of busbars and insulated conductors		<b>N/A</b>
<b>6.2</b>	<b>Connection to power</b>		<b>P</b>
6.2.1	General provisions for connection to power		<b>P</b>



IEC 62040-1			
Clause	Requirement + Test	Result - Remark	Verdict
3.2.2/RD	Multiple supply connections	Terminals for permanent connection.	P
3.2.3/RD	Permanently connected equipment	For permanent connection type, terminals for permanent connection to supply.	P
	Number of conductors, diameter of cable and conduits (mm) .....	4+PE	—
3.2.4/RD	Appliance inlets	Not used.	N/A
3.2.5/RD	Power supply cords	No power supply cord is supplied.	N/A
3.2.5.1/RD	AC power supply cords		N/A
	Type .....		—
	Rated current (A), cross-sectional area (mm <sup>2</sup> ), AWG .....		—
3.2.5.2/RD	DC power supply cords		N/A
3.2.6/RD	Cord anchorages and strain relief		N/A
	Mass of equipment (kg), pull (N).....		—
	Longitudinal displacement (mm).....		—
3.2.7/RD	Protection against mechanical damage	No parts under this unit likely to damage the power supply cord. No sharp edge	P
3.2.8/RD	Cord guards		N/A
	Diameter or minor dimension D (mm); test mass (g) .....		—
	Radius of curvature of cord (mm) .....		—
6.2.2	Means of connection .....	Wiring terminals used.	P
	More than one supply connection.....	AC mains and external battery cabinet used. Terminals for the battery not compatible with AC mains.	P
<b>6.3</b>	<b>Wiring terminals for external power conductors</b>		P
3.3/RD	Wiring terminals for connection of external conductors		P
3.3.1/RD	Wiring terminals		P
3.3.2/RD	Connection of non-detachable power supply cords		N/A
3.3.3/RD	Screw terminals	Screws and nuts conforming to ISO 261 or ISO 262 input terminal	P

IEC 62040-1			
Clause	Requirement + Test	Result - Remark	Verdict
3.3.4/RD	Conductor sizes to be connected	Conductor size will be connected according to installation manual.	P
	Rated current (A), cord/cable type, cross-sectional area (mm <sup>2</sup> )..... :	For Phase/Neutral/Battery/PE conductors. See instruction manual for the configuration for all models	—
3.3.5/RD	Wiring terminal sizes		P
	Rated current (A), type, nominal thread diameter (mm)..... :		—
3.3.6/RD	Wiring terminal design		N/A
3.3.7/RD	Grouping of wiring terminals		N/A
3.3.8/RD	Stranded wire		N/A

<b>7</b>	<b>Physical requirements</b>		<b>P</b>
7.1	<b>Enclosure</b>	Plastic enclosure. Enclosure completely enclosing hazardous parts.	P
7.2 4.1/RD	<b>Stability</b>		P
	Angle of 10°	The UPS does not overturn when: tilted to an angle of 10° use a constant downward force of 800N a force of 20% of the weight is applied from any direction.	P
	Test force (N) .....	See above	P
7.3 4.2/RD	<b>Mechanical strength</b>		P
4.2.1/RD	General	Tests performed and passed. Results see below. After tests, unit complied with the requirements of sub-clauses 2.1.1/RD, 2.6.1/RD and 2.10/RD.	P
4.2.2/RD	Steady force test, 10 N	10 N applied to all components other than enclosure.	—
4.2.3/RD	Steady force test, 30 N		N/A

IEC 62040-1			
Clause	Requirement + Test	Result - Remark	Verdict
4.2.4/RD	Steady force test, 250 N	250 N applied to outer enclosure.	P
4.2.5/RD	Impact test	See below	P
	Fall test	No hazard as result from steel ball fall test.	P
	Swing test	No hazard as result from steel ball swing test.	P
4.2.6/RD	Drop test; height (mm)..... :	Not required for this equipment.	N/A
4.2.7/RD	Stress relief test	Tested at temperature of 70°C. No distortion of enclosure observed and no hazards.	—
4.2.8/RD	Cathode ray tubes	No CRT in the unit.	N/A
	Picture tube separately certified ..... :		—
4.2.9/RD	High pressure lamps	No high pressure lamp provided.	N/A
4.2.10/RD	Wall or ceiling mounted equipment; force (N) ..... :	Not wall mounted equipment.	N/A
<b>7.4</b>	<b>Construction details</b>		<b>P</b>
7.4.1	Introduction		P
4.3.1/RD	Edges and corners	Edges and corners of the enclosure are rounded.	P
4.3.2/RD	Handles and manual controls; force (N)..... :	No handles or manual controls provided. No axial pull applied to push-buttons.	N/A
4.3.3/RD	Adjustable controls		N/A
4.3.4/RD	Securing of parts	Mechanical fixings in such a way designed that they will withstand mechanical stress occurring in normal use.	P
4.3.5/RD	Connection by plugs and sockets	No mismatching of connectors, plugs or sockets possible.	P
4.3.7/RD	Heating elements in earthed equipment		N/A
4.3.11/RD	Containers for liquids or gases		N/A
4.4/RD	Protection against hazardous moving parts		N/A
4.4.1/RD	General	Fan for skilled person only, cannot be touched.	P
4.4.2/RD	Protection in operator access areas..... :	See above	P
4.4.3/RD	Protection in restricted access locations..... :	See above	P
4.4.4/RD	Protection in service access areas	See above	P

IEC 62040-1			
Clause	Requirement + Test	Result - Remark	Verdict
4.4.5/RD	Protection against moving fan blades		N/A
4.4.5.1/RD	General		N/A
	Not considered to cause pain or injury. a) ..... :		N/A
	Is considered to cause pain, not injury. b) ..... :		N/A
	Considered to cause injury. c) ..... :	Considered	P
4.4.5.2	Protection for users		N/A
	Use of symbol or warning..... :		N/A
4.4.5.3	Protection for service persons		N/A
	Use of symbol or warning..... :	Instructed in the service instructions	N/A
4.5/RD	Thermal requirements	See clause 7.7	P
4.5.1/RD	General		P
4.5.2/RD	Temperature tests		P
	Normal load condition per Annex L ..... :	Equipment loaded with rated output power.	P
4.5.3/RD	Temperature limits for materials	(see appended table 7.7)	P
4.5.4/RD	Touch temperature limits	(see appended table 7.7)	P
4.5.5/RD	Resistance to abnormal heat ..... :	(see appended table 7.4)	P
7.4.2	Openings	See appended table 7.4.2	P
7.4.3	Gas Concentration	For the ventilation of the lead-acid battery refer to table M	P
7.4.4	Equipment movement	No castors provided.	N/A
<b>7.5</b>	<b>Resistance to fire</b>		<b>P</b>
<b>4.7/RD</b>			
4.7.1/RD	Reducing the risk of ignition and spread of flame		P
	Method 1, selection and application of components wiring and materials	(see appended table 7.5)	P
	Method 2, application of all of simulated fault condition tests	(see appended table 7.5)	P
4.7.2/RD	Conditions for a fire enclosure		P

IEC 62040-1			
Clause	Requirement + Test	Result - Remark	Verdict
4.7.2.1/RD	Parts requiring a fire enclosure	With having the following components: a) Components in primary circuits c) Insulated wiring Semiconductor devices, transistors, diodes, integrated circuits d) Resistors, capacitors, inductors The fire enclosure is required.	P
4.7.2.2/RD	Parts not requiring a fire enclosure		N/A
4.7.3/RD	Materials		P
4.7.3.1/RD	General	See below	P
4.7.3.2/RD	Materials for fire enclosures	Metal enclosure with plastic front panel.	P
4.7.3.3/RD	Materials for components and other parts outside fire enclosures		N/A
4.7.3.4/RD	Materials for components and other parts inside fire enclosures	PCB rated V-0 or better. See appended table 4.5 for details. Internal components except small parts are V-2 or better.	P
4.7.3.5/RD	Materials for air filter assemblies	No air filters provided.	N/A
4.7.3.6/RD	Materials used in high-voltage components	No high voltage components provided.	N/A
<b>7.6</b>	<b>Battery location</b>		<b>P</b>
7.6.1	Battery location and installation	Battery location and installation of the external battery cabinet and internal battery are described in detail.	P
7.6.2	Accessibility and maintainability	No requirements declared by the battery manufacturer.	N/A
7.6.3	Distance	The temperature of the electrolyte and the gas emission are within the limits of this standard (see appropriate subclauses).	P
7.6.4	Case insulation	No Ni-Cd battery used inside.	N/A
7.6.5	Wiring	The protection of connection wiring complies with subclause 3/RD.	P

IEC 62040-1			
Clause	Requirement + Test	Result - Remark	Verdict
7.6.6	Electrolyte spillage	Sealed maintenance free batteries provided with an unlikely emission of electrolyte (VRLA type).	P
7.6.7	Ventilation	For the ventilation of the lead-acid battery refer to table M.	P
7.6.8	Charging voltage	See appended table 8.3.	P
<b>7.7</b>	<b>Temperature rise</b>		<b>P</b>
4.5/RD	Thermal requirements		P
4.5.1/RD	General		P
4.5.2/RD	Temperature tests	(see appended table 7.7)	P
	Normal load condition per Annex L .....		P
4.5.3/RD	Temperature limits for materials	(see appended table 7.7)	P
4.5.4/RD	Touch temperature limits	(see appended table 7.7)	P
4.5.5/RD	Resistance to abnormal heat .....	Phenolic material	P

<b>8</b>	<b>Electrical requirements and simulated abnormal conditions</b>		<b>P</b>
<b>8.1</b>	<b>General provisions for earth leakage</b>		<b>P</b>
5.1.1/RD	General	Total touch current is depending on interconnected equipment	P
5.1.7/RD	Equipment with touch current exceeding 3,5 mA	Warning label used	P
<b>8.2</b>	<b>Electric strength</b>		<b>P</b>
<b>5.2/RD</b>			
5.2.1/RD	General	(see appended table 8.2)	P
5.2.2/RD	Test procedure	(see appended table 8.2)	P
<b>8.3</b>	<b>Abnormal operating and fault conditions</b>		<b>P</b>
8.3.1	General		P
5.3.1/RD	Protection against overload and abnormal operation	(see appended table 8.3)	P
5.3.2/RD	Motors	Approved DC fans used. Also test in appliance	P
5.3.3/RD	Transformers	(see appended Annex C)	P
5.3.4/RD	Functional insulation .....	By short-circuited, results see appended table 8.3.	P
5.3.5/RD	Electromechanical components	No electromechanical component (except for approved relays) provided.	P

IEC 62040-1			
Clause	Requirement + Test	Result - Remark	Verdict
5.3.9/RD	Compliance criteria for abnormal operating and fault conditions	No fire propagated beyond the equipment. No molten metal was emitted. Electric strength tests from primary to SELV and primary to PE were passed.	P
5.3.9.1/RD	During the tests		P
5.3.9.2/RD	After the tests		P
8.3.2	Simulation of faults	No fire or molten metal occurred and no deformation of enclosure during the tests.	P
8.3.3	Conditions for tests	No reduction of clearance and creepage distance. Electric strength test is made on basic, supplementary and reinforced insulation after test.	P

<b>9 6/RD</b>	<b>Connection to telecommunication networks</b>		<b>N/A</b>
<b>6.1/RD</b>	<b>Protection of telecommunication network service persons, and users of other equipment connected to the network, from hazards in the equipment</b>		<b>N/A</b>
6.1.1/RD	Protection from hazardous voltages		N/A
6.1.2/RD	Separation of the telecommunication network from earth		N/A
6.1.2.1/RD	Requirements		N/A
	Supply voltage (V) .....		—
	Current in the test circuit (mA).....		—
6.1.2.2/RD	Exclusions .....		N/A
<b>6.2/RD</b>	<b>Protection of equipment users from overvoltages on telecommunication networks</b>		<b>N/A</b>
6.2.1/RD	Separation requirements		N/A
6.2.2/RD	Electric strength test procedure		N/A
6.2.2.1/RD	Impulse test		N/A
6.2.2.2/RD	Steady-state test		N/A
6.2.2.3/RD	Compliance criteria		N/A
<b>6.3/RD</b>	<b>Protection of the telecommunication wiring system from overheating</b>		<b>N/A</b>
	Max. output current (A).....		—
3.5/RD	Interconnection of equipment		N/A
3.5.1/RD	General requirements		N/A

IEC 62040-1			
Clause	Requirement + Test	Result - Remark	Verdict
3.5.2/RD	Types of interconnection circuits .....		N/A
3.5.3/RD	ELV circuits as interconnection circuits		N/A
3.5.4/RD	Data ports for additional equipment		N/A
2.1.3/RD	Protection in restricted access locations		N/A
2.3.1/RD	Limits		N/A
	Type of TNV circuits .....		—
2.3.2/RD	Separation from other circuits and from accessible parts		N/A
2.3.2.1/RD	General requirements		N/A
2.3.2.2/RD	Protection by basic insulation		N/A
2.3.2.3/RD	Protection by earthing		N/A
2.3.2.4/RD	Protection by other constructions .....		N/A
2.3.3/RD	Separation from hazardous voltages		N/A
	Insulation employed.....		—
2.3.4/RD	Connection of TNV circuits to other circuits		N/A
	Insulation employed.....		—
2.3.5/RD	Test for operating voltages generated externally		N/A
2.6.5.8/RD	Reliance on telecommunication network or cable distribution system		N/A
2.10.3.3/RD	Clearances in primary circuits		N/A
2.10.3.4/RD	Clearances in secondary circuits		N/A
2.10.4/RD	Creepage distances		N/A
2.10.4.1/RD	General		N/A
2.10.4.2/RD	Material group and comparative tracking index		N/A
	CTI tests .....		—
2.10.4.3/RD	Minimum creepage distances		N/A
<b>M/RD</b>	<b>Annex M, CRITERIA FOR TELEPHONE RINGING SIGNALS (see 2.3.1/RD)</b>		N/A
M.1/RD	Introduction		N/A
M.2 /RD	Method A		N/A
M.3/RD	Method B		N/A
M.3.1/RD	Ringling signal		N/A



IEC 62040-1			
Clause	Requirement + Test	Result - Remark	Verdict
M.3.1.1/R D	Frequency (Hz) .....		—
M.3.1.2/R D	Voltage (V) .....		—
M.3.1.3/R D	Cadence; time (s), voltage (V) .....		—
M.3.1.4/R D	Single fault current (mA).....		—
M.3.2/RD	Tripping device and monitoring voltage .....		N/A
M.3.2.1/R D	Conditions for use of a tripping device or a monitoring voltage		—
M.3.2.2/R D	Tripping device		N/A
M.3.2.3/R D	Monitoring voltage (V) .....		N/A

A/RD	Annex A, Tests for resistance to heat and fire	P
<b>A.1/RD</b>	<b>Flammability test for fire enclosures of movable equipment having a total mass exceeding 18 kg, and of stationary equipment (see 4.7.3.2/RD)</b>	N/A
A.1.1/RD	Samples.....	—
	Wall thickness (mm) .....	—
A.1.2/RD	Conditioning of samples; temperature (°C).....	N/A
A.1.3/RD	Mounting of samples .....	N/A
A.1.4/RD	Test flame (see IEC 60695-11-3)	N/A
	Flame A, B, C or D.....	—
A.1.5/RD	Test procedure	N/A
A.1.6/RD	Compliance criteria	N/A
	Sample 1 burning time (s).....	—
	Sample 2 burning time (s).....	—
	Sample 3 burning time (s).....	—
<b>A.2/RD</b>	<b>Flammability test for fire enclosures of movable equipment having a total mass not exceeding 18 kg, and for material and components located inside fire enclosures (see 4.7.3.2/RD and 4.7.3.4/RD)</b>	N/A
A.2.1/RD	Samples, material .....	—
	Wall thickness (mm) .....	—
A.2.2/RD	Conditioning of samples; temperature (°C).....	N/A
A.2.3/RD	Mounting of samples .....	N/A
A.2.4/RD	Test flame (see IEC 60695-11-4)	N/A

IEC 62040-1			
Clause	Requirement + Test	Result - Remark	Verdict
	Flame A, B or C .....		—
A.2.5/RD	Test procedure		N/A
A.2.6/RD	Compliance criteria		N/A
	Sample 1 burning time (s) .....		—
	Sample 2 burning time (s) .....		—
	Sample 3 burning time (s) .....		—
A.2.7/RD	Alternative test acc. to IEC 60695-11-5, cl. 5 and 9		N/A
	Sample 1 burning time (s) .....		—
	Sample 2 burning time (s) .....		—
	Sample 3 burning time (s) .....		—
A.3/RD	Hot flaming oil test (see 4.6.2/RD)		N/A
A.3.1/RD	Mounting of samples		N/A
A.3.2/RD	Test procedure		N/A
A.3.3/RD	Compliance criterion		N/A

<b>B/RD</b>	<b>Annex B, Motor tests under abnormal conditions (see 4.7.2.2/RD and 5.3.2/RD)</b>		<b>P</b>
<b>B.1/RD</b>	<b>General requirements</b>	Approved DC fan used. See appended table 4.5	N/A
	Position .....		—
	Manufacturer .....		—
	Type .....		—
	Rated values .....		—
<b>B.2/RD</b>	<b>Test conditions</b>		N/A
<b>B.3/RD</b>	<b>Maximum temperatures</b>		N/A
<b>B.4/RD</b>	<b>Running overload test</b>		N/A
<b>B.5/RD</b>	<b>Locked-rotor overload test</b>		N/A
	Test duration (days) .....		—
	Electric strength test: test voltage (V) .....		—
<b>B.6/RD</b>	<b>Running overload test for d.c. motors in secondary circuits</b>		N/A
B.6.1/RD	General		N/A
B.6.2/RD	Test procedure		N/A
B.6.3/RD	Alternative test procedure		N/A
B.6.4/RD	Electric strength test; test voltage (V) .....		N/A

IEC 62040-1			
Clause	Requirement + Test	Result - Remark	Verdict
<b>B.7/RD</b>	<b>Locked-rotor overload test for d.c. motors in secondary circuits</b>		N/A
B.7.1/RD	General		N/A
B.7.2/RD	Test procedure		N/A
B.7.3/RD	Alternative test procedure		N/A
B.7.4/RD	Electric strength test; test voltage (V)..... :		N/A
B.8/RD	Test for motors with capacitors		N/A
B.9/RD	Test for three-phase motors		N/A
B.10/RD	Test for series motors		N/A
	Operating voltage (V) ..... :		—

<b>C/RD</b>	<b>Annex C, Transformers (see 1.5.4/RD and 5.3.3/RD)</b>		<b>P</b>
	Position..... :	T2 transformer on DR4 board T1 transformer on TF2 board	—
	Manufacturer..... :	(see appended table 4.5)	—
	Type..... :	(see appended table 4.5)	—
	Rated values..... :	(see appended table 4.5)	—
	Method of protection..... :	Circuit design (inherently)	—
C.1/RD	Overload test	(see appended table 8.3 and 5.3/RD)	P
C.2/RD	Insulation	(see appended table C.2/RD and Sub-clause 8.2)	P
	Protection from displacement of windings..... :	Secured by tubing and insulation tape. See appended table C.2/RD	P

<b>D/RD</b>	<b>Annex D, Measuring instruments for touch current tests (see 5.1.4/RD)</b>		<b>P</b>
<b>D.1/RD</b>	<b>Measuring instrument</b>	Measuring instrument according to figure D.1 was used.	P
<b>D.2/RD</b>	<b>Alternative measuring instrument</b>		N/A

<b>E/RD</b>	<b>Annex E, Temperature rise of a winding (see Annex E/RD)</b>		<b>N/A</b>

IEC 62040-1			
Clause	Requirement + Test	Result - Remark	Verdict
<b>F/RD</b>	<b>Annex F, Measurements of clearances and creepage distance (see 2.10/RD and Annex G/RD)</b>		<b>N/A</b>

<b>G/RD</b>	<b>Annex G, Alternative method for determining minimum clearances</b>		<b>N/A</b>
<b>G.1/RD</b>	<b>Clearances</b>		N/A
G.1.1/RD	General		N/A
G.1.2/RD	Summary of the procedure for determining minimum clearances		N/A
<b>G.2/RD</b>	<b>Determination of mains transient voltage (V)</b>		N/A
G.2.1/RD	AC mains supply .....		N/A
G.2.2/RD	Earthed d.c. mains supplies .....		N/A
G.2.3/RD	Unearthed d.c. mains supplies .....		N/A
G.2.4/RD	Battery operation.....		N/A
<b>G.3/RD</b>	<b>Determination of telecommunication network transient voltage (V) .....</b>		N/A
<b>G.4/RD</b>	<b>Determination of required withstand voltage (V)</b>		N/A
G.4.1/RD	Mains transients and internal repetitive peaks .....		N/A
G.4.2/RD	Transients from telecommunication networks .....		N/A
G.4.3/RD	Combination of transients		N/A
G.4.4/RD	Transients from cable distribution systems		N/A
<b>G.5/RD</b>	<b>Measurement of transient voltages (V)</b>		N/A
	a) Transients from a mains supply		N/A
	For an a.c. mains supply		N/A
	For a d.c. mains supply		N/A
	b) Transients from a telecommunication network		N/A
<b>G.6/RD</b>	<b>Determination of minimum clearances.....</b>		N/A

<b>H</b>	<b>Annex H, Guidance on protection against ingress of water and foreign objects (see IEC 60529)</b>		<b>N/A</b>
----------	---	--	------------

<b>I</b>	<b>Annex I, Backfeed protection test</b>		<b>N/A</b>
<b>I.1</b>	<b>General</b>		N/A
<b>I.2</b>	<b>Test for pluggable UPS</b>		N/A
<b>I.3</b>	<b>Test for permanently connected UPS</b>		N/A
<b>I.4</b>	<b>Load-induced change of reference potential</b>		N/A

IEC 62040-1			
Clause	Requirement + Test	Result - Remark	Verdict
<b>I.5</b>	<b>Solid-state backfeed protection (see clause 7.1-7.5 of IEC 62040-2 and clause 7.1-7.2 of IEC 62040-3)</b>		<b>N/A</b>

<b>J/RD</b>	<b>Annex J, Table of electrochemical potentials (see 2.6.5.6/RD)</b>	<b>P</b>
	Metal(s) used ..... : Copper and steel.	—

<b>K/RD</b>	<b>Annex K, Thermal controls (see 1.5.3/RD and 5.3.8/RD)</b>	<b>N/A</b>
<b>K.1/RD</b>	<b>Making and breaking capacity</b>	<b>N/A</b>
<b>K.2 /RD</b>	<b>Thermostat reliability; operating voltage (V) ..... :</b>	<b>N/A</b>
<b>K.3/RD</b>	<b>Thermostat endurance test; operating voltage (V) ..... :</b>	<b>N/A</b>
<b>K.4/RD</b>	<b>Temperature limiter endurance; operating voltage (V) ..... :</b>	<b>N/A</b>
<b>K.5/RD</b>	<b>Thermal cut-out reliability</b>	<b>N/A</b>
<b>K.6/RD</b>	<b>Stability of operation</b>	<b>N/A</b>

<b>L</b>	<b>Annex L, Reference loads</b>	<b>P</b>
<b>L.1</b>	<b>General</b>	<b>P</b>
<b>L.2</b>	<b>Reference resistive load</b>	<b>P</b>
<b>L.3</b>	<b>Reference inductive-resistive load</b>	<b>—</b>
<b>L.4</b>	<b>Reference capacitive-resistive loads</b>	<b>P</b>
<b>L.5</b>	<b>Reference non-linear load</b>	<b>P</b>
L.5.1	General	P
L.5.2	Test method	P
L.5.3	Connection of the non-linear reference load	—

<b>M</b>	<b>Annex M, Ventilation of battery compartments</b>	<b>P</b>
<b>M.1</b>	<b>General</b>	<b>P</b>
	Sufficient openings and a suitable arrangement of components (circuit breaker) are provided in such a way that a local concentration of hydrogen and oxygen is not possible. No requirement regarding the separation of operational arcing parts from battery vents/valves.	

IEC 62040-1			
Clause	Requirement + Test	Result - Remark	Verdict
<b>M.2</b>	<b>Normal conditions</b>	See appended table M	P
<b>M.3</b>	<b>Blocked conditions</b>	Block test applied, see appended table 8.3	P
<b>M.4</b>	<b>Overcharge conditions</b>	See appended table M.	P

<b>N</b>	<b>Annex N, Minimum and maximum cross-sections of copper conductors suitable for connection (see 6.3)</b>		<b>N/A</b>
----------	---	--	------------

<b>U/RD</b>	<b>Annex U, Insulated winding wires for use without interleaved insulation (see 2.10.5.4/RD)</b>		<b>N/A</b>

<b>V/RD</b>	<b>Annex V, AC POWER DISTRIBUTION SYSTEMS (see 1.6.1/RD)</b>		<b>P</b>
V.1/RD	Introduction		P
V.2/RD	TN power distribution systems		P
V.3/RD	TT power distribution systems		N/A
V.4/RD	IT power distribution systems		N/A

IEC 62040-1			
Clause	Requirement + Test	Result - Remark	Verdict

4.6, 1.6.2/RD		TABLE: Electrical Data (in normal conditions)					P
fuse #	I rated (A)	U (V)	P (W)	I (A)	I fuse (A)	condition/status	
	--	342/50Hz	26316	44.30	354.42	Condition A: Load 380Vac/50Hz 25KW	
	--	342/60Hz	26316	44.30	354.42		
	90	380/50Hz	26316	39.87	318.98		
	90	380/60Hz	26316	39.87	318.98		
	90	400/50Hz	26261	38.06	304.47		
	90	400/60Hz	26261	38.06	304.47		
	90	415/50Hz	26455	36.74	293.94		
	90	415/60Hz	26455	36.74	293.94		
	--	440/50Hz	26596	34.50	275.96		
	--	440/60Hz	26596	34.50	275.96		
	--	342/50Hz	26288	44.26	44.26	Condition B: Load 400Vac/50Hz 25KW	
	--	342/60Hz	26288	44.26	44.26		
	90	380/50Hz	26288	39.83	39.83		
	90	380/60Hz	26288	39.83	39.83		
	90	400/50Hz	26233	38.02	38.02		
	90	400/60Hz	26233	38.02	38.02		
	90	415/50Hz	26427	36.70	36.70		
	90	415/60Hz	26427	36.70	36.70		
	--	440/50Hz	26567	34.46	34.46		
	--	440/60Hz	26567	34.46	34.46		
	--	342/50Hz	26288	44.26	44.26	Condition C: Load 415Vac/50Hz 25KW	
	--	342/60Hz	26288	44.26	44.26		
	90	380/50Hz	26288	39.83	39.83		
	90	380/60Hz	26288	39.83	39.83		
	90	400/50Hz	26233	38.02	38.02		
	90	400/60Hz	26233	38.02	38.02		
	90	415/50Hz	26427	36.70	36.70		
	90	415/60Hz	26427	36.70	36.70		
	--	440/50Hz	26567	34.46	34.46		
	--	440/60Hz	26567	34.46	34.46		

IEC 62040-1						
Clause	Requirement + Test				Result - Remark	Verdict
	--	342/50Hz	26316	44.30	44.30	Condition A: Load 380Vac/60Hz 25KW
	--	342/60Hz	26316	44.30	44.30	
	90	380/50Hz	26316	39.87	39.87	
	90	380/60Hz	26316	39.87	39.87	
	90	400/50Hz	26261	38.06	38.06	
	90	400/60Hz	26261	38.06	38.06	
	90	415/50Hz	26455	36.74	36.74	
	90	415/60Hz	26455	36.74	36.74	
	--	440/50Hz	26596	34.50	34.50	
	--	440/60Hz	26596	34.50	34.50	
	--	342/50Hz	26288	44.26	44.26	Condition B: Load 400Vac/60Hz 25KW
	--	342/60Hz	26288	44.26	44.26	
	90	380/50Hz	26288	39.83	39.83	
	90	380/60Hz	26288	39.83	39.83	
	90	400/50Hz	26233	38.02	38.02	
	90	400/60Hz	26233	38.02	38.02	
	90	415/50Hz	26427	36.70	36.70	
	90	415/60Hz	26427	36.70	36.70	
	--	440/50Hz	26567	34.46	34.46	
	--	440/60Hz	26567	34.46	34.46	
	--	342/50Hz	26288	44.26	44.26	Condition C: Load 415Vac/60Hz 25KW
	--	342/60Hz	26288	44.26	44.26	
	90	380/50Hz	26288	39.83	39.83	
	90	380/60Hz	26288	39.83	39.83	
	90	400/50Hz	26233	38.02	38.02	
	90	400/60Hz	26233	38.02	38.02	
	90	415/50Hz	26427	36.70	36.70	
	90	415/60Hz	26427	36.70	36.70	
	--	440/50Hz	26567	34.46	34.46	
	--	440/60Hz	26567	34.46	34.46	
Supplementary information:						

<b>5.1.1</b> <b>2.1.1.5/RD</b>	<b>TABLE: Max. V, A, VA Test</b>	<b>N/A</b>
-----------------------------------	----------------------------------	------------



IEC 62040-1				
Clause	Requirement + Test		Result - Remark	Verdict
Voltage (rated) (V)	Current (rated) (A)	Voltage (max.) (V)	Current (max.) (A)	VA (max.) (VA)
--	--	--	--	--
Supplementary information:				

5.1.1 2.1.1.5/RD	TABLE: Stored Energy			N/A
Capacitance C (μF)	Voltage U (V)		Energy E (J)	
--	--		--	
Supplementary information:				

5.1.1 2.1.1.7/ RD	TABLE: discharge of capacitors in the primary circuit				P
Condition	$\tau$ calculated (s)	$\tau$ measured (s)	$t_{u \rightarrow 0V}$ (s)	Comments	
Input L1-N	--	0.48	1.92	Tested at online mode with batteries	
Input L2-N	--	0.44	1.76		
Input L3-N	--	0.44	1.76		
Input L1-PE	--	0.46	1.84		
Input L2-PE	--	0.44	1.76		
Input L3-PE	--	0.42	1.68		
Input N-PE	--	0	0		
BAT+-PE		0.21	0.84	Battery mode	
BAT--PE		0.23	0.92		
Input L1-N	--	0.25	1.0	Tested at bypass mode without batteries	
Input L2-N	--	0.23	0.92		
Input L3-N	--	0.25	1.0		
Input L1-PE	--	0.48	1.92		
Input L2-PE	--	0.5	2.0		
Input L3-PE	--	0.5	2.0		
Input N-PE	--	0	0		
Supplementary information:					

5.2.1	TABLE: Evaluation Of Voltage Limiting Components In SELV Circuits	P
-------	---	---

IEC 62040-1				
Clause	Requirement + Test	Result - Remark		Verdict
<b>2.2/RD</b>				
Component (measured between)		Max. voltage (V) (normal operation)		Voltage Limiting Components
		V peak	V d.c.	
TF2 board				
T1 After pin 9 to D1		11.8	11.4	--
After D4 to pin 9		14.8	14.2	--
PS1203_TF3 board				
T1 After D2 to Pin9		14.7	14	--
After pin 9 to D3		11.8	11.3	--
Fault test performed on voltage limiting components		Voltage measured (V) in SELV circuits (V peak or V d.c.)		
--		--		
Supplementary information: s-c=Short circuit				

<b>5.2.3</b> <b>2.4.2/RD</b>	<b>Table: Limited current circuit measurement</b>					<b>N/A</b>
Location	Voltage (mV)	Current (mA)	Freq. (kHz)	Limit (mA <sub>p</sub> )	Comments	
Supplementary information:						

<b>5.3.1 and</b> <b>2.6.3.4/RD</b>	<b>Table: Resistance of earthing measurement</b>				<b>P</b>
Location	Resistance measured (mΩ)	Voltage drop measured (V)	Comments		
Input PE to earthed enclosure	--	1.2	180A/10min Limit value: ≤2.5V		
Supplementary information:					

<b>5.5.4</b>	<b>Table: Short-time withstand current test</b>			<b>N/A</b>
Rated max. output current	Announced withstand current	Test current	Comments	
--	--	--	--	
Supplementary information: Specified I <sub>cc</sub> not exceed 10kA, no test necessary.				

IEC 62040-1			
Clause	Requirement + Test	Result - Remark	Verdict

5.2.5 2.5/RD	TABLE: Limited Power Sources					N/A
Circuit output tested:						
Note: Measured Uoc (V) with all load circuits disconnected:						
Components	Test condition (Single fault)	Uoc (V)	Isc (A)		VA	
			Meas.	Limit	Meas.	Limit
--	--	--	--	--	--	--
Supplementary information: Sc=Short circuit, Oc=Open circuit						

5.7 2.10.2/RD	Table: Working Voltage Measurement				P
Location	RMS voltage (V)	Peak voltage (V)	Comments		
<b>TF2 board</b>					
T1 Pin2--6	92.7	138			
T1 Pin2--7	93.2	146			
T1 Pin2--9	93.0	140			
T1 Pin2--10	92.7	138			
T1 Pin4--6	93.2	<b>150</b>	<b>Maximum Vpeak</b>		
T1 Pin4--7	92.7	142			
T1 Pin4--9	92.7	138			
T1 Pin4--10	<b>93.4</b>	150	<b>Maximum Vrms</b>		
<b>DR4 board</b>					
T2(pin1-8)	<b>565</b>	<b>417</b>	<b>Maximum Vpeak and Maximum Vrms</b>		
T2(pin1-9)	545	414			
T2(pin1-10)	530	406			
T2(pin1-11)	545	412			
T2(pin1-12)	515	402			
T2(pin1-13)	55.0	30.2			
T2(pin1-14)	65.0	32.7			
T2(pin4-8)	425	391			
T2(pin4-9)	415	392			

IEC 62040-1			
Clause	Requirement + Test	Result - Remark	Verdict
T2(pin4-10)	485	392	
T2(pin4-11)	415	392	
T2(pin4-12)	545	392	
T2(pin4-13)	395	131	
T2(pin4-14)	425	117	
T2(pin6-8)	235	50.0	
T2(pin6-9)	165	26.9	
T2(pin6-10)	75	14.1	
T2(pin6-11)	155	28.6	
T2(pin6-12)	65	14.1	
T2(pin6-13)	85	49.5	
T2(pin6-14)	105	16.6	
T2(pin7-8)	95	24.6	
T2(pin7-9)	35	13.0	
T2(pin7-10)	85	25.3	
T2(pin7-11)	35	11.9	
T2(pin7-12)	155	35.9	
T2(pin7-13)	55	19.5	
T2(pin7-14)	55	31.2	
Supplementary information: Sc=Short circuit, Oc=Open circuit			

5.7, 2.10.3/RD	TABLE: Clearance And Creepage Distance Measurements						P
	clearance cl and creepage distance dcr at/of:	Up (V)	U r.m.s. (V)	Required cl (mm)	cl (mm)	required dcr (mm)	dcr (mm)
Whole unit							
	Metal enclosure to bare pin of battery terminal	<420	<240	2.0	5.5	2.5	5.5
	Primary pin to earthed metal plate on Input EMI PCB	<420	<240	2.0	5.0	2.5	>5.0
	Primary pin to earthed metal enclosure on Output EMI PCB	<420	<240	2.0	8.0	2.5	>8.0

IEC 62040-1						
Clause	Requirement + Test			Result - Remark		Verdict
Primary trace to enclosure	<420	<250	4.0	7.5	5.0	7.5
<b>DR4 board</b>						
Primary to secondary of Y-cap (C89, C90)	<420	<250	4.0	6.6	5.0	6.6
Primary to secondary of Opto-coupler (U13)	<420	<250	4.0	5.7	5.0	5.7
Primary traces to secondary traces under T2	565	417	4.4	8.8	8.4	8.8
<b>TF2 board</b>						
Primary to secondary of Y-cap(C68, C69, C70)	<420	<250	4.0	7.1	5.0	7.1
Primary to secondary of Opto-coupler (U8, U9, U10, U11, U12)	<420	<250	4.0	5.7	5.0	5.7
Primary to secondary under T1	<420	<250	4.0	8.2	5.0	8.2
Supplementary information: *FI=Functional insulation, BI=Basic insulation, RI=Reinforced insulation. Unless otherwise specified, the worst conditions of Cl. & Cr. In above mentioned locations have been considered and listed. Test with model HR33025CL						

5.7, 2.10.5.2/ RD	TABLE: Distance Through Insulation Measurements				P
Distance through insulation di at/of:	U r.m.s. (V)	Test voltage (V)	Required di (mm)	di (mm)	
Optocouplers (U1, U2, U3,U4, U5, U6,U7,U8,U9, U10,U11,U12)	250	AC 3000	0.4	>0.4*	
Plastic enclosure	250	AC 3000	2.5	2.5	
Supplementary information: *see information in table 4.5 for details.					

7.4, 4.5.5/RD	TABLE: Ball Pressure Test of Thermoplastics			N/A
Allowed impression diameter (mm) .....				—
Object/ Part No./ Material	Manufacturer/ trademark	Test temperature (°C)	Impression diameter (mm)	
--	--	--	--	
Supplementary information: Phenolic material bobbin used in Transformer and Line Choke without test.				

IEC 62040-1			
Clause	Requirement + Test	Result - Remark	Verdict

<b>7.4.2 4.6/RD</b>	<b>TABLE: Openings</b>			<b>P</b>
Location	Size (mm)	Comments		
Front	Diameter=3mm	Numerous oblong opening for ventilation		
Rear	Diameter=3mm	Numerous hole for ventilation		
Side	None	--		
Top/bottom	None	--		
Supplementary information:				

<b>7.5 4.7/RD</b>	<b>TABLE: Resistance to fire</b>					<b>P</b>
Part	Manufacturer of material	Type of material	Thickness (mm)	Flammability class	Evidence	
Enclosure	SABIC JAPAN L L C	C2950(GG)(C)	2.5 mm	5VB	UL	
PCB	Interchangeable	Interchangeable	2.0 mm	V-0	UL	
Supplementary information: see appended table 4.5						

<b>7.7, 4.5/RD</b>	<b>TABLE: Heating Test</b>					<b>P</b>
	Test voltage (V).....	323V/60Hz	457V/50Hz	Battery Mode	--	—
	Ambient (°C).....	40	40	40	--	—
Thermocouple Locations		Max. temperature measured, (°C)				Max. temperature limit, (°C)
<b>UPS internal</b>						
Enclosure (plastic panel)		45.1	54.6	43.2	--	95
Enclosure (metal)		49.2	56.3	50.3	--	70
AC terminal		61.2	57.9	60.4	--	Ref.
DC terminal		56.3	58.7	52.9	--	Ref.
DC Fan		59.8	59.4	59.1	--	80
Battery wire '+'		47.3	55.2	58.5	--	105
Primary wire		56.9	57.8	57.7	--	105
<b>DR1 board</b>						

IEC 62040-1					
Clause	Requirement + Test	Result - Remark			Verdict
Y Capacitor	58.3	57.5	58.7	--	85
PCB near S1	57.3	53.4	60.1	--	130
Transformer (T7) coil	56.3	55.7	58.4	--	110
Transformer (T7) core	51.2	51.0	52.8	--	100
Opto coupler (U2)	52.3	51.8	52.5	--	100
PCB near transformer (T7)	51.8	50.6	51.2	--	130
Inductor	90.5	83.8	86.6	--	130
<b>DR2 board</b>					
Y Capacitor	50.8	49.4	50.7	--	85
PCB near Q6	46.6	44.5	48.1	--	130
<b>DR3 board</b>					
Y Capacitor	49.6	46.4	50.2	--	100
PCB near Q5	60.5	57.4	58.7	--	130
<b>DR4 board</b>					
Y Capacitor	48.7	46.6	48.2	--	85
Transformer (T2) coil	51.8	49.2	52.4	--	110
Transformer (T2) core	48.3	45.6	46.3	--	110
PCB near transformer (T2)	44.4	42.5	42.9	--	130
Output relay	59.8	59.3	58.9	--	85
Ambient	40.0	40.0	40.0	--	--
Supplementary information:					
1. The temperatures were measured under the worst case normal mode defined in 1.2.2.1/RD and as described in sub-clause 4.6 at voltages as described above.					
2. With a specified ambient temperature of 40°C.					
3. Test for model HR33025CL and output loading with 380V, 38A, 25kW					

7.7, 4.5/RD	TABLE: Heating test, resistance method					N/A
	Test voltage (V) .....					—
	Ambient, t <sub>1</sub> (°C) .....					—
	Ambient, t <sub>2</sub> (°C) .....					—
Temperature rise of winding	R <sub>1</sub> (Ω)	R <sub>2</sub> (Ω)	ΔT (K)	Max. dT (K)	Insulation class	
--	--	--	--	--	--	
Supplementary information:						

IEC 62040-1			
Clause	Requirement + Test	Result - Remark	Verdict

8 5.1/RD	TABLE: touch current measurement			P
Measured between:	Measured (mA)	Limit (mA)	Comments/conditions	
Unit on	0.2 / 0.18	3.5	Switch "e" open, L/N to PE, no load	
Unit on	0.003 / 0.003	3.5	Switch "e" close, L/N to front panel (with foil)	
Unit on	0.001 / 0.002	3.5	Switch "e" close, L/N to RS232 port	
Supplementary information:				

8.2 5.2/RD	TABLE: Dielectric Strength		P
Test voltage applied between:	Test potential applied (V)	Breakdown / flashover (Yes/No)	
Primary to Secondary interface (interface of Port for MCU interface board and CSB board)	DC 4242	No	
Input/output R/S/T to earth	DC 2121	No	
Battery +/- to earth	DC 2121	No	
Primary to secondary in safety isolation transformers (T2 of DR4 board)	DC 4242	No	
Primary to secondary in safety isolation transformers (T1 of TF2 board)	DC 4242	No	
Supplementary information:			

8.3 5.3/RD	TABLE: Fault condition tests					P
	Ambient temperature (°C) :				See below	—
	Power source for EUT: Manufacturer, model/type, output rating :					—
Component No.	Fault	Supply voltage (V)	Test time	Fuse #	Fuse current (A)	Observation
DR1 board						



IEC 62040-1						
Clause	Requirement + Test				Result - Remark	Verdict
Q17 (c-e)	s-c	415	1s	F23 on DR1 board	30	UPS output normally, fuse F23 opened, charger shut down.  Q17 damaged. Output voltage: 397.3V.
Q17(g-e)	s-c	415	1s	F23 on DR1 board	30	UPS output normally, charger shut down. recoverable after fault removed, no damaged. Output voltage: 397.3V.
Q17(c-g)	s-c	415	1s	F23 on DR1 board	30	UPS output normally, fuse F23 opened, charger shut down.  Q17 damaged. Output voltage: 397.3V.
DR2 board						
Q6(c-e)	s-c	415	1s	F1, F9, F16 on DR1 board	--	UPS output normally, fuse F1, F9, F16 opened, charger shut down.  A+ IGBT damaged. Output voltage: 397.3V.
Q6 (c-g)	s-c	415	1s	F1, F9, F16 on DR1 board	--	UPS output normally, fuse F1, F9, F16 opened, charger shut down.  A+ IGBT damaged. Output voltage: 397.3V.
Q6 (g-e)	s-c	415	10min	F1, F9, F16 on DR1 board	--	UPS output normally, charger shut down. Recoverable after fault removed, no damaged. Output voltage: 397.3V.
BUS E-capacitor	s-c	415	1s	F1,F2,F3	--	UPS output normally, charger shut down. fuse F1/F2/F3 opened, IGBT of A/B/C phase hazards, No damaged. Output voltage: 397.3V.
DR4 board						

IEC 62040-1						
Clause	Requirement + Test				Result - Remark	Verdict
Bus Voltage detecting resistor R207	s-c	415	10min	--	--	UPS work normally, no hazards. Charge voltage: 576V, Output voltage: 397.3V.
Bus Voltage detecting resistor R207	o-c	415	10min	--	--	UPS output normally, charger shut down. Output voltage: 397.3V.
TF2 board						
Transformer T1 pin 9-10	s-c	415	10min	F1	--	UPS output and the charger operate normally, No damaged. Charge voltage: 576V, Output voltage: 397.3V.
Opto coupler U12 (pin1-2)	s-c	415	10min	---	--	UPS work normally, no damaged. Charge voltage: 576V, Output voltage: 397.3V.
Opto coupler U12 (pin3-4)	s-c	415	10min	--	--	UPS work normally, no damaged. Charge voltage: 576V, Output voltage: 397.3V.
Opto coupler U12 pin1	O-c	415				UPS work normally, no damaged. Charge voltage: 576V, Output voltage: 397.3V.
Opto coupler U12 pin3	O-c	415				UPS work normally, no damaged. Charge voltage: 576V, Output voltage: 397.3V.
D14	s-c	415	10min	--	--	UPS work normally, no damaged. Charge voltage:576V, Output voltage: 397.3V.
Whole unit						
Output	s-c	415	1s	--	-	UPS output shut down immediately, the charger operate normally, no damaged. Charge voltage: 576V, Output voltage: 0V.

IEC 62040-1						
Clause	Requirement + Test				Result - Remark	Verdict
Output	s-c	battery	1s	--	-	UPS output shut down immediately, no damaged. Charge voltage: 0V, Output voltage: 0V.
Output	o-l	415	15min	--	-	UPS output shut down at condition of 5min at 100% load + 5min at 117% load + 2s at 133% load.
Output	o-l	Battery mode	15min	--	--	UPS output shut down at condition of 5min at 100% load + 5min at 117% load + 2s at 133% load.
Ventilation openings	Block-ed	415	30min.	--	--	UPS shut down at temperature protection, after the temperature is below 60°C, UPS open up. Repeat the cycle continuously.
Ventilation openings	Block-ed	Battery mode	30min	--	--	UPS shut down at temperature protection, after the temperature is below 60°C, UPS open up. Repeat the cycle continuously.
Fan	Locked	415	30mins	--	--	UPS shut down at temperature protection, after the temperature is below 60°C, UPS open up. Repeat the cycle continuously.
Fan	Locked	Battery mode	30mins	--	--	UPS shut down at temperature protection, after the temperature is below 60°C, UPS open up. Repeat the cycle continuously.
<p>Supplementary information: s-c: short circuit, o-c: open circuit, o-l: over load</p> <ol style="list-style-type: none"> <li>1. SELV outputs did not exceed 42.4 V<sub>peak</sub> or 60 V<sub>dc</sub> and did not exceed the limit of 71 V<sub>peak</sub> or 120 V<sub>dc</sub> within 0.2 second after abnormal conditions were applied.</li> <li>2. The Electric Strength Tests were successfully conducted after the completion of fault.</li> <li>3. Transformer winding and core temperature limit is 164°C (175-10-(40-39))</li> <li>4. Test with model HR33025CL</li> </ol>						

C.2/RD	TABLE: transformers						P
Loc.	Tested insulation	Working voltage peak / V	Working voltage rms / V	Required electric strength	Required clearance / mm	Required creepage distance / mm	Required distance thr. insul.
		(2.10.2)	(2.10.2)	(5.2)	(2.10.3)	(2.10.4)	(2.10.5)

IEC 62040-1							
Clause	Requirement + Test	Result - Remark				Verdict	
T2 on DR4 board	secondary winding to core: Reinforced insulation	420	250	3000	4.4	8.4	*
T2 on DR4 board	primary pin to secondary winding: Reinforced insulation	516	250	3000	2.2	4.2	TIW
T1 on TF2 board	Transformer primary winding to secondary winding	420	250	3000VAC	2.2	4.2	*
T1 on TF2 board	Transformer primary to core	448	250	1674	2.0	2.5	*
T1 on TF2 board	Transformer secondary to core	448	250	1674	2.0	2.5	*
Loc.	Tested insulation			Test voltage/ V	Measured clearance / mm	Measured creepage dist./ mm	Measured distance thr. insul. / mm; number of layers
T2 on DR4 board	reinforced insulation			3000	11.8	11.8	*
T2 on DR4 board	reinforced insulation			3000	10.4	10.4	TIW
T1 on TF2 board	Transformer primary winding to secondary winding			3000VAC	6.5	6.5	*
T1 on TF2 board	Transformer primary to core			1500VAC	4.2	4.5	*
T1 on TF2 board	Transformer secondary to core			1500VAC	4.2	4.5	*
Supplementary information: *) 2 layers or 3 layers or Annex U All transformer sources are identical except manufacturer.							

IEC 62040-1			
Clause	Requirement + Test	Result - Remark	Verdict

<b>C.2/RD</b>	<b>TABLE: transformers</b>		<b>P</b>
---------------	----------------------------	--	----------

Transformer: T2 on APS board

**1. 安装尺寸及外形图 (CONFIGURATION & DIMENSIONS) (使用ER40型16Pin骨架)**

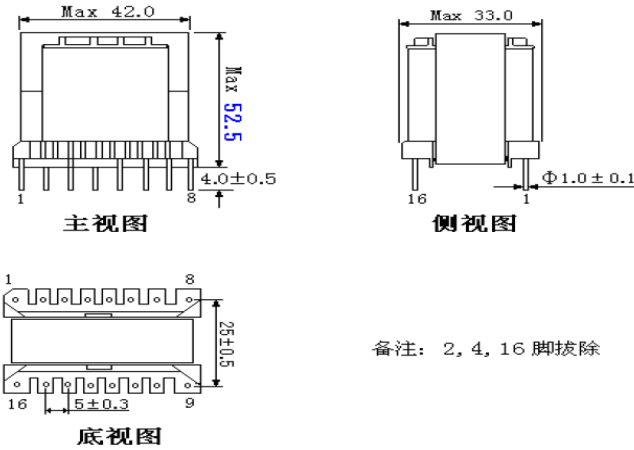

备注: 2, 4, 16 脚拔除

**4. 线圈联线图 (SCHEMATIC)**

**3. 内部结构图 (WINDING CONSTRUCTION)**

(用图示表明骨架中各绕组、绝缘层、隔离带的位置分布)

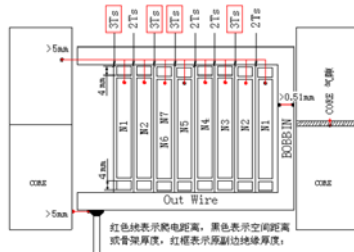

红色线表示爬电距离, 黄色表示空间距离或骨架厚度, 红框表示原副边绝缘厚度。

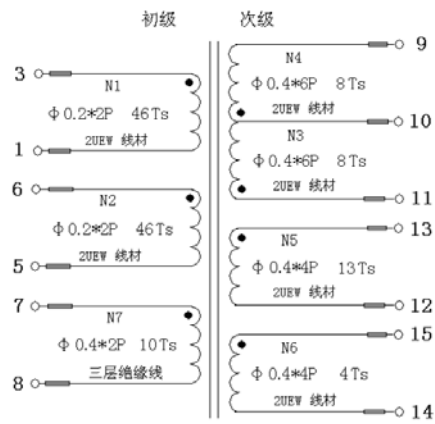

备注:  
绕线前, 调整骨架插入接嘴的方向, 以最少绕组的交叉排线为准。

铁氟龙套管

Transformer: T1 on SELV board  
Construction / winding diagram

**1. 安装尺寸及外形图 (CONFIGURATION & DIMENSIONS) (EI16骨架)**

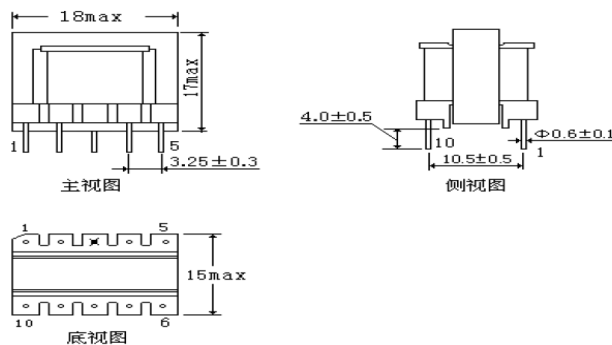

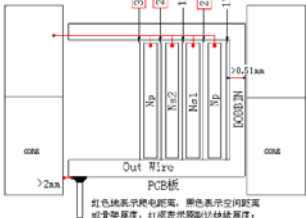
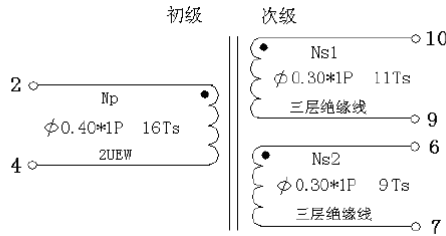
IEC 62040-1			
Clause	Requirement + Test	Result - Remark	Verdict
<p><b>3. 内部结构图 (WINDING CONSTRUCTION)</b> (用图示表明骨架中各绕组、绝缘层、隔离带的位置分布)</p>  <p>红色线表示绝缘层, 蓝色表示空层距离或骨架厚度, 红色表示绝缘层绝缘厚度。</p>		<p><b>4. 线圈联线图 (SCHEMATIC)</b></p> 	

M	Ventilation of battery compartments	N/A
	<p>The required dimension for the ventilation openings will be calculated with the following formula:</p> $A \geq Q/360 \text{ [m}^2\text{]}$ <p>with <math>Q = 0.054 * n * I * C</math></p> <p>where:</p> <p>Q : airflow in m<sup>3</sup>/h  n : number of battery cells  I : constant factor (0,2A/100Ah for valve regulated lead acid batteries)  C : is the battery nominal capacity in Ah at the 10h discharge rate</p> <p>With the specific data for the UPS the following dimension for the ventilation openings is required:</p> <p>n :  C :</p> $A \geq (0.054 * n * 0.2 A/100 Ah * C)/360$ <p>A ≥</p> <p>Verdict</p> <p>The size of ventilation openings in battery cabinet exceeds the required airflow by far (as well as the UPS).</p>	

IEC 62040-1					
Clause	Requirement + Test	Result - Remark			Verdict
<b>4.5</b>	<b>TABLE: Critical components information</b>				<b>P</b>
Object / part No.	Manufacturer/ trademark	Type / model	Technical data	Standard	Mark(s) of conformity <sup>1</sup>
<b>Whole unit</b>					
Front panel	SABIC JAPAN L L C	C2950 (GG)(C)	5VB, 85°C, Min. thickness 2.5mm	UL 746D	UL E207780
DC fan	NMB	09225VA24 QAL01	DC24V, 0.49A, 11.8W	UL 507	UL: E89936
Insulation sheet	ITW ELECTRONICS COMPONENTS/ PRODUCTS (SHANGHAI) CO LTD	Formex GK-10	minimum thickness 0.4 mm, V-0, 115°C	UL 94 UL 746C	UL: E256266
Alternative	FORMEX, DIV OF ILLINOIS TOOL WORKS INC, FORMERLY	Formex GK-10	minimum thickness 0.4 mm, V-0, 115°C	UL 94 UL 746C	UL: E121855
Wire	Interchangeable	Interchangeable	--	UL758	UL: E314168
<b>ON ASY01_PS1601_DR1</b>					
DC capacitor(C211,C212)	Jianghai	CD293-390UF	450V, 390uF, 85°C	--	UL
Diode(D21,D22,D75,D76)	Fairchild	FFP30S60 STU	600V;30A	--	--
IGBT(Q17,Q18)	Infineon	IKW15N65 H5	15A/650V	--	--
Inductor(L19, L20)	FOT	UMX3315L 3	Class F	IEC/EN 62040-1	Test with appliance
Thyristor(S1, S2,S3,S4,S5, S6,S7,S8,S9, S10,S11,S12)	VISHAY	VS-50TPS12Pbf	50A 1200V	--	--
Inductor(L21, L22, L23)	FOT	UMX3315L 4	Class F	IEC/EN 62040-1	Test with appliance
Y2 capacitor(C25)	Interchangeable	CS11-E2GA222M YNS	250VAC/ 2200pF	IEC 60384-14	VDE:12432 1
Y1 capacitor(C26 ,C229,C230, C231,C232,C 233,C234)	Interchangeable	CD16-E2GA472M YGS	400VAC/ 4700pF	IEC 60384-14	VDE:12432 1

IEC 62040-1					
Clause	Requirement + Test		Result - Remark		Verdict
Transformer (T7)	SIDNA	UMS33D1T1	Class B	IEC/EN 62040-1	Test with appliance
Inductor(L4,L5,L6,L7,L8,L9)	FOT	DT23010L2	Class F	IEC/EN 62040-1	Test with appliance
FUSE(F23, F24,F1,F2,F3, F9,F10,F11, F14, F15,F16)	BUSSMANN	BK-GBH-V030A6FR	500VAC/30A	--	UL:E56412
Transformer (T2,T3,T5,T6)	Boulder	HTX11CT1	Class B	IEC/EN 62040-1	Test with appliance
PCB	Interchangeable	Interchangeable	V-0, 130°C	--	UL
Relay(RLY2, RLY3)	TYCO	OZ-SS-124LM1	16A;240VAC;24VDC	--	UL:E82292
Relay(RLY1)	SONGCHUAN	894H-2AH1-F-C	12A;240VAC;12VDC	--	TUV
ON ASY01_PS1601_DR2					
IGBT(Q1,Q2, Q3, Q4,Q5, Q6)	Infineon	IKW75N65EH5	75A/650V	--	--
Diode (D97,D98,D99,D100, D101,D102)	Fairchild	FFH75H60S	600V;75A	--	--
Diode (D11,D80,D81,D82, D83,D84)	Fairchild	FFP30S60STU	600V;30A	--	--
Current Transformer	Boulder	UMX33CT1	Class B	IEC/EN 62040-1	Test with appliance
DC capacitor (C19,C22,C90,C91)	Jianghai	CD294	450VDC;1000uF, 105°C	--	UL
Y2capacitor(C92,C93)	Interchangeable	CS11-E2GA222M YNS	2200pF, 250VAC	IEC 60384-14	VDE
PCB	Interchangeable	Interchangeable	V-0, 130°C	--	UL
ON ASY01_PS1601_DR3					



IEC 62040-1					
Clause	Requirement + Test	Result - Remark	Verdict		
Y1 capacitor(C18 ,C19,C20,C21 , C99,C100)	Interchangeable	CD16-E2GA472M YGS	4700pF, 250VAC	IEC 60384-14	VDE
Y2capacitor(C127,C23)	Interchangeable	CS11-E2GA222M YNS	2200pF, 250VAC	IEC 60384-14	VDE
IGBT(Q9,Q10 ,Q13,Q15,Q16, Q17)	Infineon	IKW75N65 EL5	650V;75A	--	--
IGBT(Q1,Q5, Q11,Q12,Q14 , Q18)	Infineon	IKW50N65 ES5	650V;50A	--	--
D49,D50,D51, D52,D53,D54	Fairchild	FFH75H60 S	600V;75A	--	--
DC capacitor (C1, C2, C3, C4, C152, C153, C154, C155)	Jianghai	CD294	450VDC;1000uF, 105°C	--	UL
PCB	Interchangeable	Interchangeable	V-0, 130°C	--	UL
ON ASY01_PS1601_DR4					
Inductor (L1, L2, L3)	FOT	PM25CL1	Class F	IEC/EN 62040-1	Test with appliance
Transformer (T1)	SIDNA	UMS33P1T 2	Class B	IEC/EN 62040-1	Test with appliance
Transformer (T2)	Boulder	UMX3310T 1	Class B	IEC/EN 62040-1	Test with appliance
HALL	LEM	HX50-P	--	--	--
Y2 capacitor(C89 ,C90)	Interchangeable	CS11-E2GA222M YNS	2200pF, 250VAC	IEC 60384-14	VDE
PCB	Interchangeable	Interchangeable	V-0, 130°C	--	UL
FUSE(F23,F24,F1,F2,F3, F9,F10,F11 ,F14,F15,F16)	BUSSMANN	BK-GBH-V030A6FR	500VAC/30A	--	UL: E56412

IEC 62040-1					
Clause	Requirement + Test	Result - Remark	Verdict		
FUSE(F9,F10)	HOLLY	30N050H1	250V;5A	--	UL: E156471
FUSE(F3,F4,F5,F6,F7,F8)	BUSSMANN	BK/ABC-V-30	250VAC;30A	--	UL:E14853
Relay(RLY1,RLY2,RLY3)	TYCO	T92S7D12-24	24VDC/30A/250VAC	--	UL:E22575
ON PS1608_CT1					
Inductor(L2,L3,L4)	SIDNA	UMS33P1L2	Class B	IEC/EN 62040-1	Test with appliance
PCB	Interchangeable	Interchangeable	V-0, 130°C	--	UL
ON PS1608_CT2					
Inductor(L3,L4)	SIDNA	UMS33P1L2	Class B	IEC/EN 62040-1	Test with appliance
PCB	Interchangeable	Interchangeable	V-0, 130°C	--	UL
ASY01_PS1601_TF3					
FUSE(F1,F2,F3,F4)	BUSSMANN	BK-GBH-V030A6FR	500VAC/30A	--	UL:E56412
Optocouplers (U3,U4)	SHARP	PC817X3NIP0F	--	--	UL:E64380
PCB	Interchangeable	Interchangeable	V-0, 130°C	--	UL
ASY01_PS1203_PW5					
Optocouplers (U1)	SHARP	PC123X5YIP0F	--	--	UL:E64380
PCB	Interchangeable	Interchangeable	V-0, 130°C	--	UL
ASY01_PS1608_TF2					
Y2 capacitor(C68,C69,C70)	Interchangeable	CS11-E2GA222M YNS	2200pF, 250VAC	IEC 60384-14	VDE
Optocouplers (U8,U9,U10,U11,U12)	SHARP	PC817X3NIP0F	--	--	UL:E64380
Transformer (T1)	Boulder	UMX33MN 1T1	CLASS B	IEC/EN 62040-1	Test with appliance
FUSE(F1/1)	Hollyland	50CF F630mAH 250V	630mAH 250V	--	UL:E156471

IEC 62040-1					
Clause	Requirement + Test		Result - Remark		Verdict
PCB	Interchangeable	Interchangeable	V-0, 130°C	--	UL
ASY01_PS1608_TF5					
Optocouplers (U6,U7,U8,U9)	SHARP	PC123X5YI P0F	--	--	UL:E64380
Optocouplers (U20)	AVAGO	HCMR201-550E	--	--	UL:E64380
Transformer (T1)	Boulder	UMX33MN 1T1	CLASS B	IEC/EN 62040-1	Test with appliance
FUSE(F1/1)	Hollyland	50CF F630mAH 250V	630mAH 250V	--	UL:E15647 1
PCB	Interchangeable	Interchangeable	V-0, 130°C	--	UL
ASY01_PS1608_DR5					
Y2 capacitor (C1)	Interchangeable	CD16-E2GA472M YGS	250VAC/ 2200pF	IEC 60384-14	VDE:12432 1
Thyristor (Q1,Q2,Q3,Q4,Q5,Q6)	VISHAY	70TPS12	70A 1200V	--	--
Current Transformer	Boulder	HT2340CT 1	Class B	IEC/EN 62040-1	Test with appliance
PCB	Interchangeable	Interchangeable	V-0, 130°C	--	UL
ASY01_PS1608_EM1					
Y2 capacitor(C9, C10,C11)	Interchangeable	CS11-E2GA222M YNS	250VAC/ 2200pF	IEC 60384-14	VDE:12432 1
Y1capacitor(C18,C19,C20,C21,C22,C23)	Interchangeable	CD16-E2GA472M YGS	400VAC/ 4700pF	IEC 60384-14	VDE:12432 1
FUSE(F1,F2, F3,F4,F5,F6, F7)	TAMURA	T3F	2A/250V	--	VDE
PCB	Interchangeable	Interchangeable	V-0, 130°C	--	UL
ASY01_PS1302_TF1					
PCB	Interchangeable	Interchangeable	V-0, 130°C	--	UL
ASY01_PS1608_KY1					

IEC 62040-1					
Clause	Requirement + Test		Result - Remark	Verdict	
PCB	Interchangeable	Interchangeable	V-0, 130°C	--	UL
PCB_PS1410_CV1					
PCB	Interchangeable	Interchangeable	V-0, 130°C	--	UL
PCB_PS1409_CP2					
PCB	Interchangeable	Interchangeable	V-0, 130°C	--	UL
Supplementary information:					
1) Provided evidence ensures the agreed level of compliance. See OD-2039.					

IEC 62040-1_1A - ATTACHMENT 1			
Clause	Requirement + Test	Result - Remark	Verdict

<b>ATTACHMENT TO TEST REPORT IEC 62040-1</b> <b>EUROPEAN GROUP DIFFERENCES AND NATIONAL DIFFERENCES</b> Uninterruptible power systems (UPS) – <b>Part 1: General and safety requirements for UPS</b>			
<b>Differences according to.....:</b>		EN 62040-1:2008	
<b>Attachment Form No. ....:</b>		EU_GD_IEC62040_1A	
<b>Attachment Originator.....:</b>		Nemko	
<b>Master Attachment.....:</b>		Date (2010-06)	
<b>Copyright © 2010 IEC System for Conformity Testing and Certification of Electrical Equipment (IECEE), Geneva, Switzerland. All rights reserved.</b>			

<b>EN 62040-1:2008 – CENELEC COMMON MODIFICATIONS</b>
---

EN 62040-1, GROUP DIFFERENCES (CENELEC common modifications EN)			
Clause	Requirement + Test	Result - Remark	Verdict
Contents	Add the following annexes: Annex ZA (normative) Annex ZB (normative)	Normative references to international publications with their corresponding European publications Special national conditions	N/A

IEC 62040-1_1A - ATTACHMENT 1			
Clause	Requirement + Test	Result - Remark	Verdict

ZA	<b>NORMATIVE REFERENCES TO INTERNATIONAL PUBLICATIONS WITH THEIR CORRESPONDING EUROPEAN PUBLICATIONS</b>			—		
	<p>The following referenced documents are indispensable for the application of this document. For dated references, only the edition cited applies. For undated references, the latest edition of the referenced document (including any amendments) applies.</p> <p>Note: When an international publication has been modified by common modifications, indicated by (mod), the relevant EN/HD Applies.</p>					
	<u>Publication</u>	<u>Year</u>	<u>Title</u>		<u>EN/HD</u>	<u>Year</u>
	IEC 60364-4-42	- <sup>1)</sup>	Electrical installations of buildings - Part 4-42: Protection for safety - Protection against thermal effects		-	-
	IEC 60417	Data-base	Graphical symbols for use on equipment		-	-
	IEC 60529	- <sup>1)</sup>	Degrees of protection provided by enclosures (IP Code)		EN 60529 + corr. May	1991 <sup>2)</sup> 1993
	IEC 60664	Series	Insulation coordination for equipment within low-voltage systems		EN 60664	Series
	IEC/TR 60755	- <sup>1)</sup>	General requirements for residual current operated protective devices		-	-
	IEC 60950-1 (mod)	2005	Information technology equipment - Safety - Part 1: General requirements		EN 60950-1	2006
	IEC 61000-2-2	- <sup>1)</sup>	Electromagnetic compatibility (EMC) - Part 2-2: Environment - Compatibility levels for low-frequency conducted disturbances and signalling in public low-voltage power supply systems		EN 61000-2-2	2002 <sup>2)</sup>
	IEC 61008-1 (mod)	- <sup>1)</sup>	Residual current operated circuit-breakers without integral overcurrent protection for household and similar uses (RCCB's) - Part 1: General rules		EN 61008-1 + A11	2004 <sup>2)</sup> 2007
	IEC 61009-1 (mod)	- <sup>1)</sup>	Residual current operated circuit-breakers with integral overcurrent protection for household and similar uses (RCBO's) - Part 1: General rules		EN 61009-1 + corr. July + A11	2004 <sup>2)</sup> 2006 2008
	IEC 62040-2	2005	Uninterruptible power systems (UPS) - Part 2: Electromagnetic compatibility (EMC) requirements		EN 62040-2 + corr. November	2006 2006
IEC 62040-3 (mod)	1999	Uninterruptible power systems (UPS) - Part 3: Method of specifying the performance and test requirements	EN 62040-3	2001		
			<sup>1)</sup> Undated reference. <sup>2)</sup> Valid edition at date of issue.			

IEC 62040-1_1A - ATTACHMENT 1			
Clause	Requirement + Test	Result - Remark	Verdict

<p style="text-align: center;"><b>ZB ANNEX (normative)</b> <b>SPECIAL NATIONAL CONDITIONS (EN)</b></p> <p>The FI, NO and SE - SNCs originate from IEC 60950-1 2<sup>nd</sup> Edition, which is the reference document (RD) for IEC 62040-1. The national requirements are included in IEC 62040-1 through the following statement in the scope of the standard: <i>“National requirements additional to those in IEC 60950-1 apply and are found as notes under relevant clauses of the RD.”</i></p> <p>The national requirements have not been specifically listed in the EN 62040-1:2008. If demanded, CLC/TC 22X will be requested to take proper measures to complete EN 62040-1 with Annexes ZB containing the SNCs as presented below.</p> <p>EN 62040-1:2008 supersedes EN 62040-1-1:2003. As a reference, see also SNCs for Finland, Norway and Sweden as included in the earlier EN 62040-1-1:2003</p>			
Clause	Requirement + Test	Result - Remark	Verdict
4.7.3	<p>In Finland, Norway and Sweden, when safety relies upon connection to the safety earth (see 5.3), a pluggable equipment type A UPS shall have a marking on the equipment, stating that the UPS must be connected to an earthed mains socket-outlet.</p> <p>The marking text in the applicable countries shall be as follows:</p> <p>In Finland: "Laite on liitettävä suojakoskettimilla varustettuun pistorasiaan"</p> <p>In Norway: "Apparatet må tilkoples jordet stikkontakt"</p> <p>In Sweden: "Apparaten skall anslutas till jordat uttag"</p>		N/A
4.7.11	<p>In Norway, because of a widely used IT power system, equipment shall be designed or modified for connection to such a system and shall be marked by a label with the following wording in Norwegian:</p> <p>"Apparatet er egnet for tilkopling til et IT forsyningsnett"</p>		P
9	<p>In Finland, Norway and Sweden requirements of 6.1.2.1 and 6.1.2.2 in Annex ZB of EN 60950-1:2001 apply.</p>		N/A

ATTACHMENT Photos



Figure 1: External view



Figure 2: External view



ATTACHMENT Photos



Figure 3: Rear view

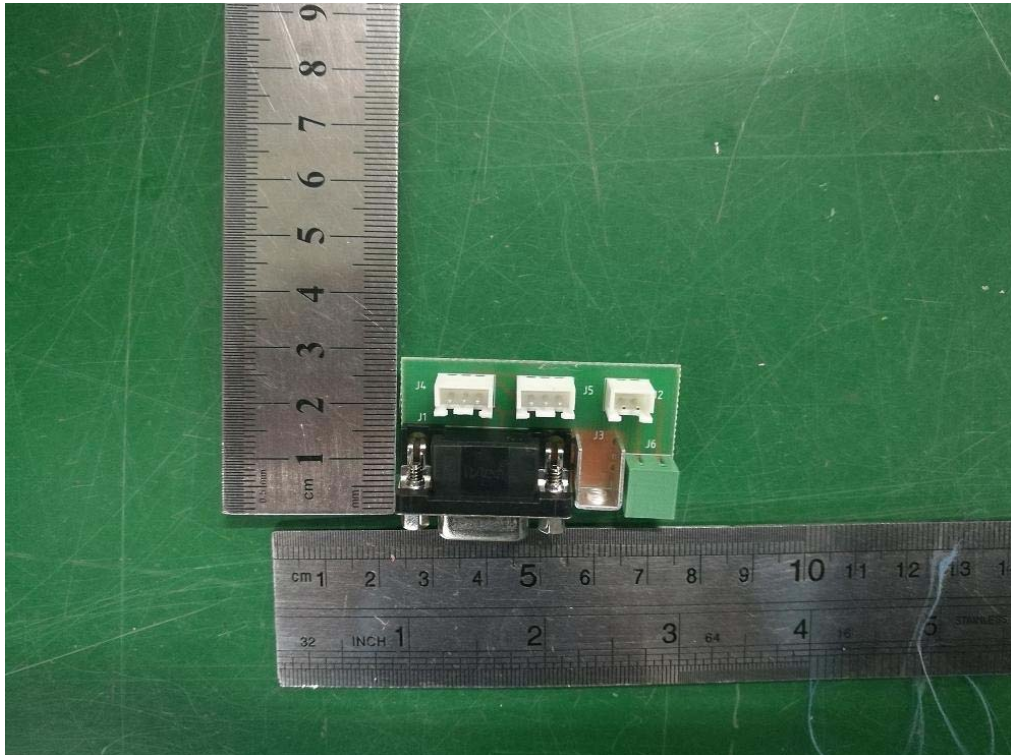

Figure 4: PCB view

ATTACHMENT Photos

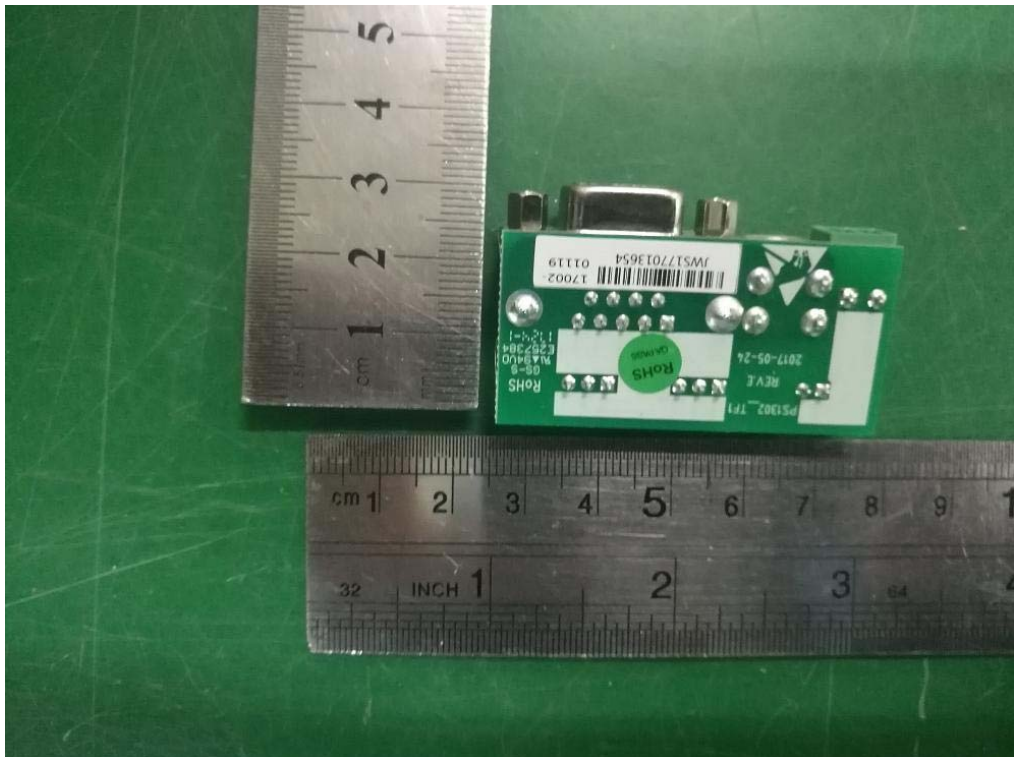

Figure 5: PCB view

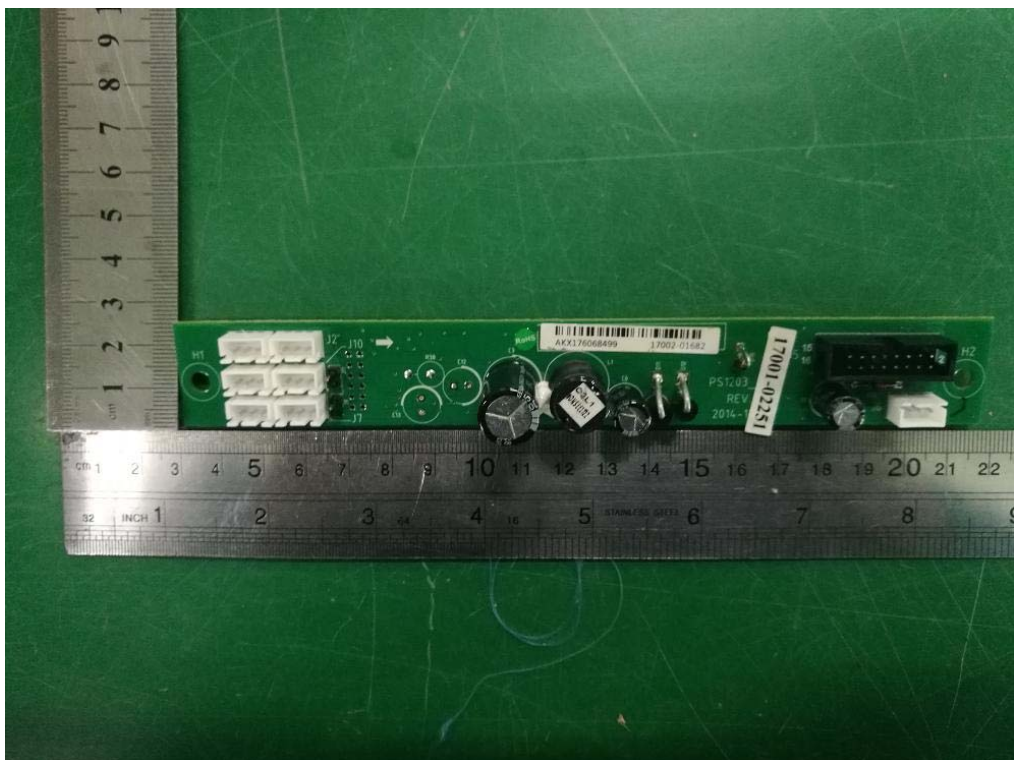

Figure 6: PCB view

ATTACHMENT Photos

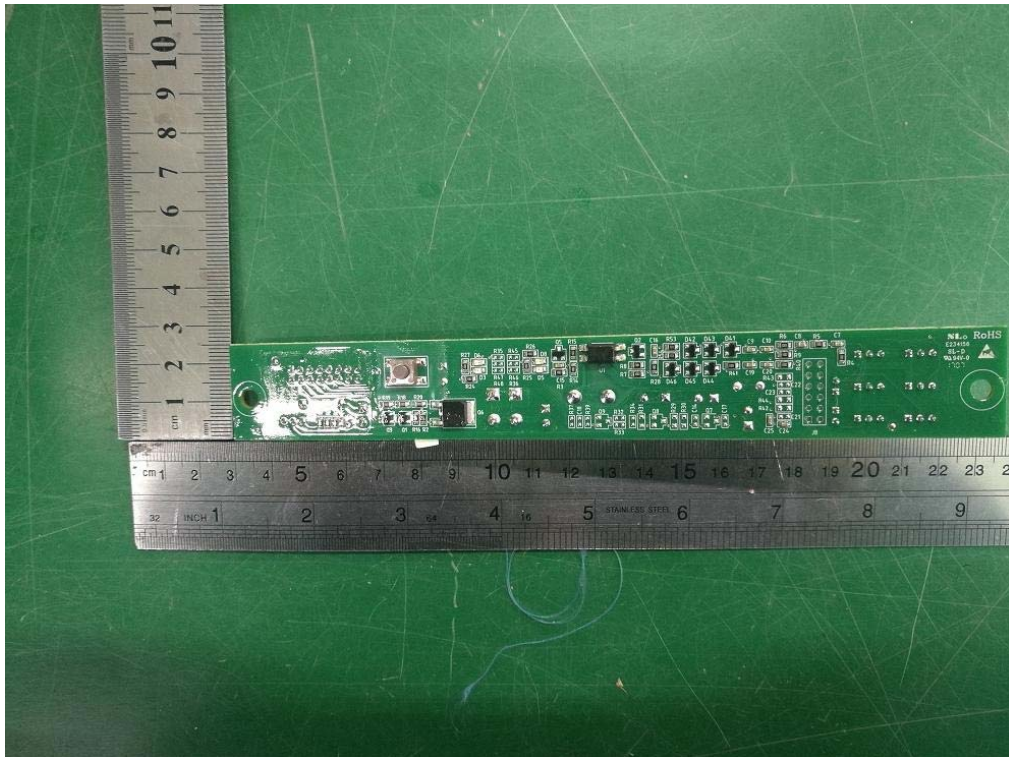

Figure 7: PCB trace view

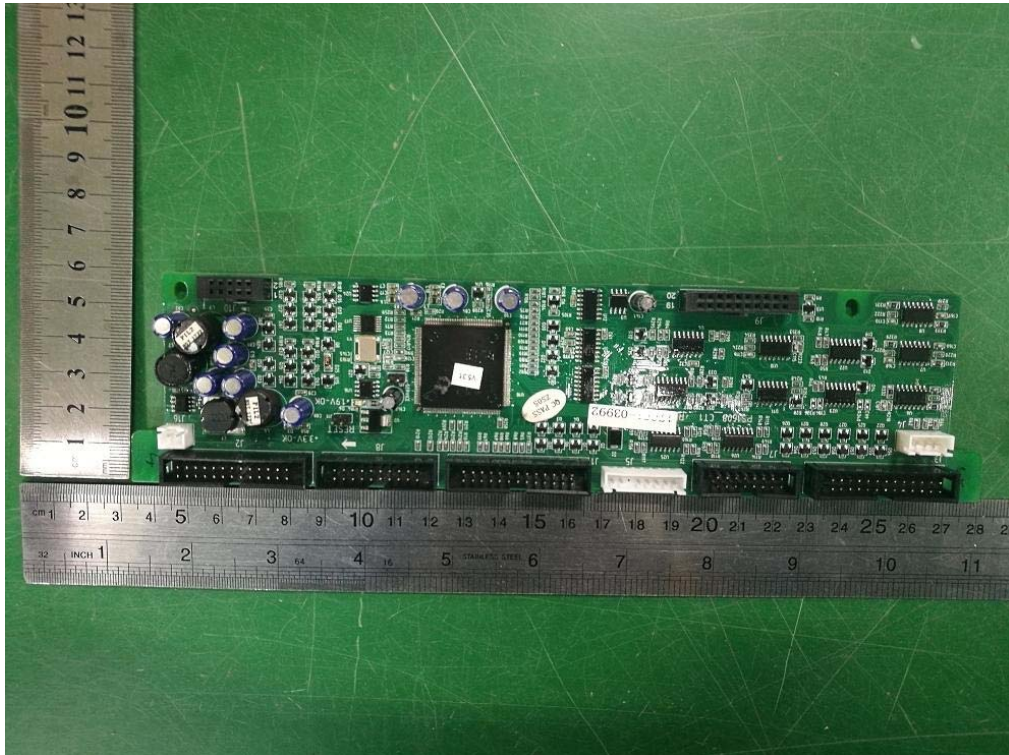

Figure 8: PCB component view

ATTACHMENT Photos

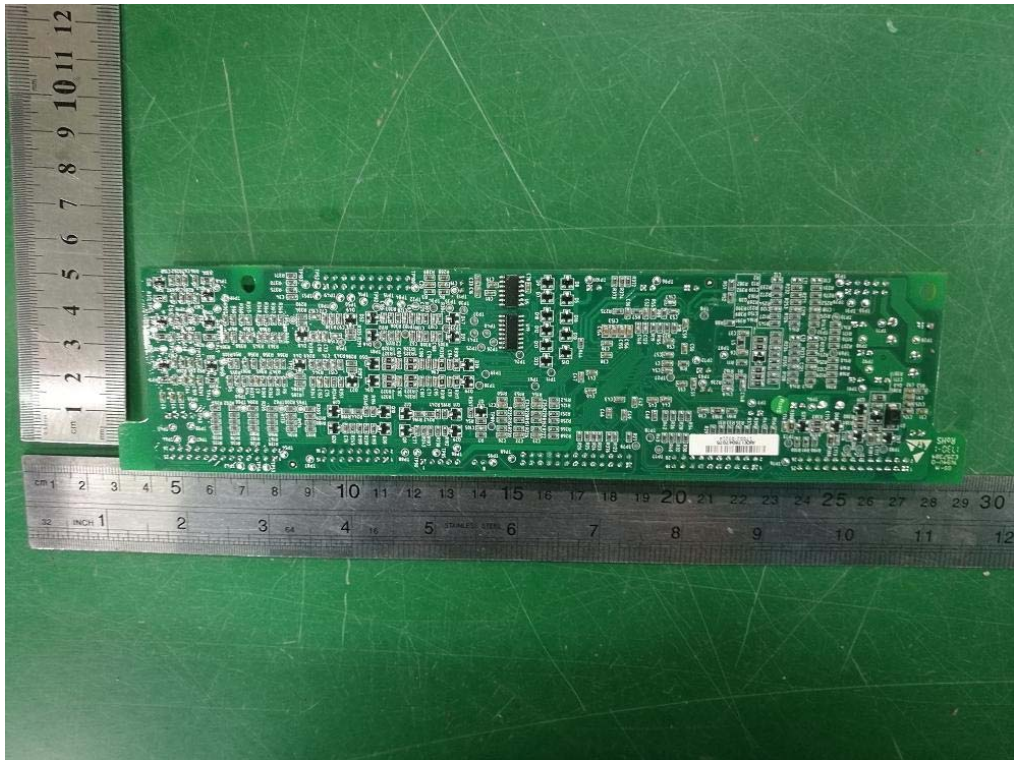

Figure 9: PCB trace view

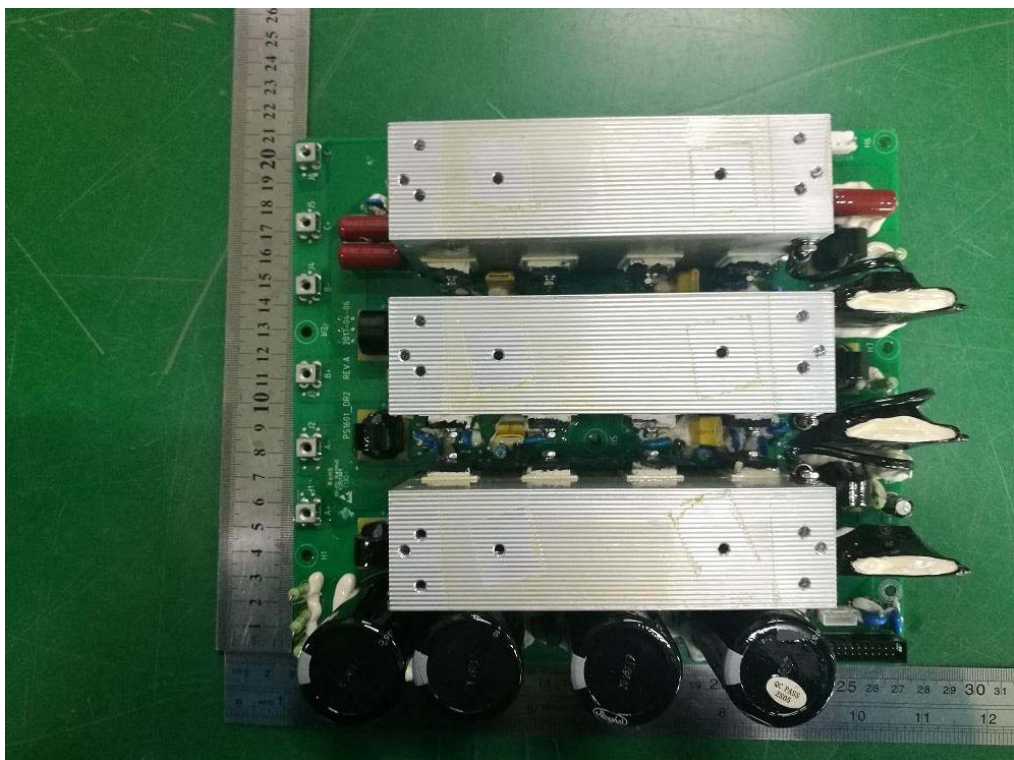

Figure 10: PCB component view

ATTACHMENT Photos

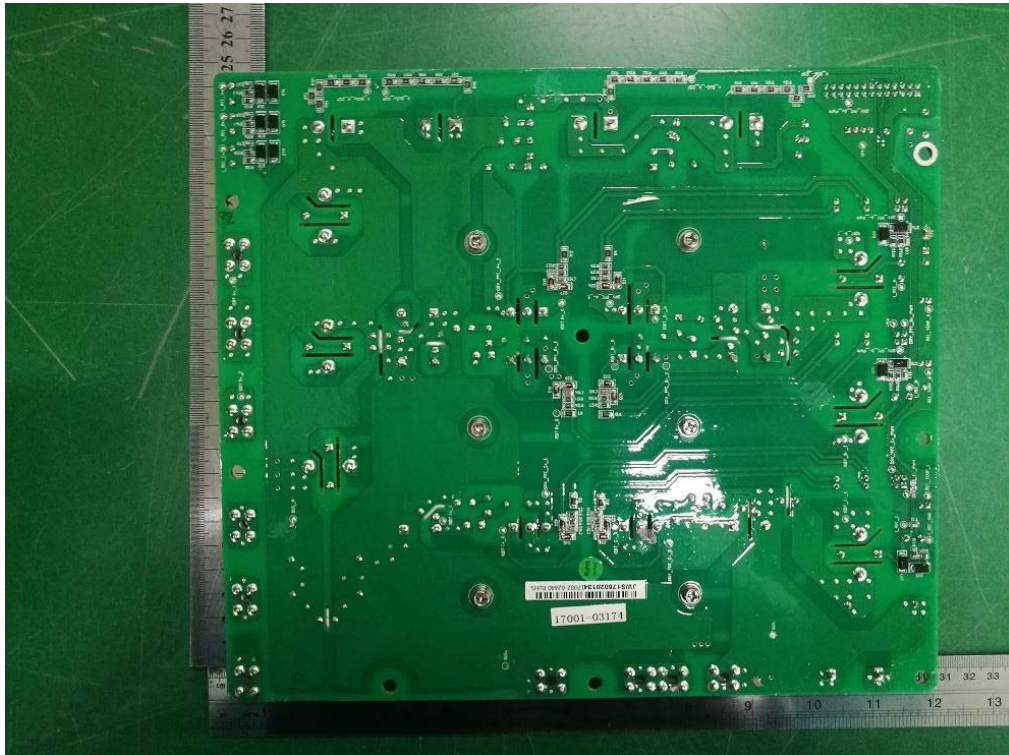

Figure 11: PCB trace view

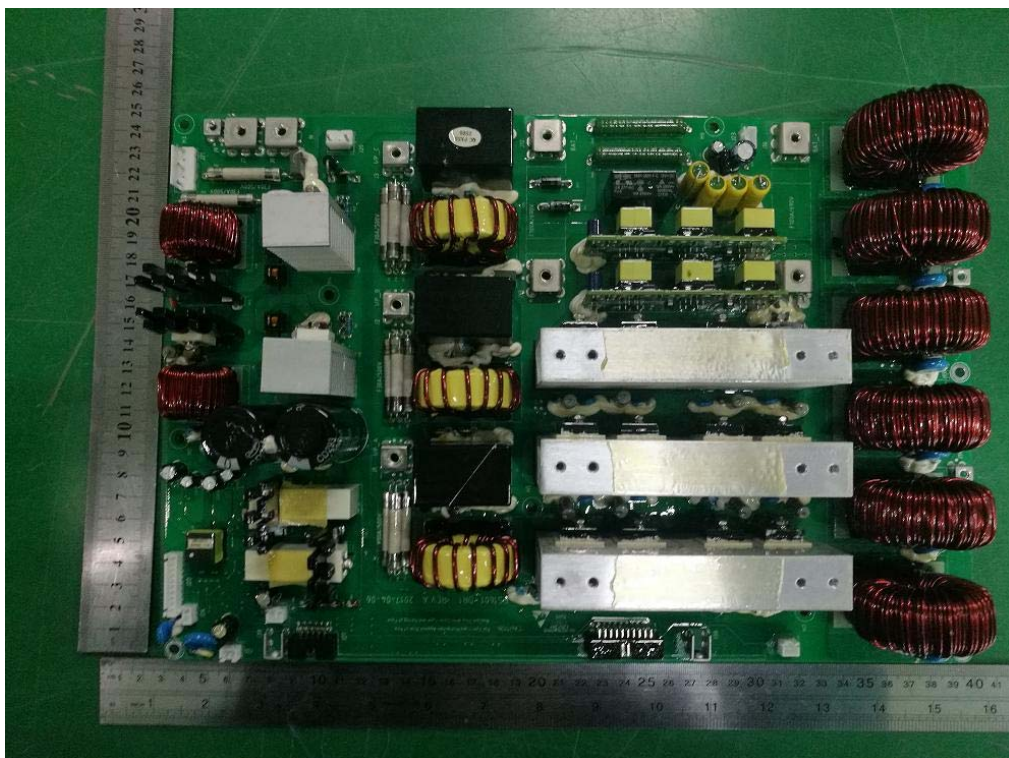

Figure 12: PCB component view

ATTACHMENT Photos

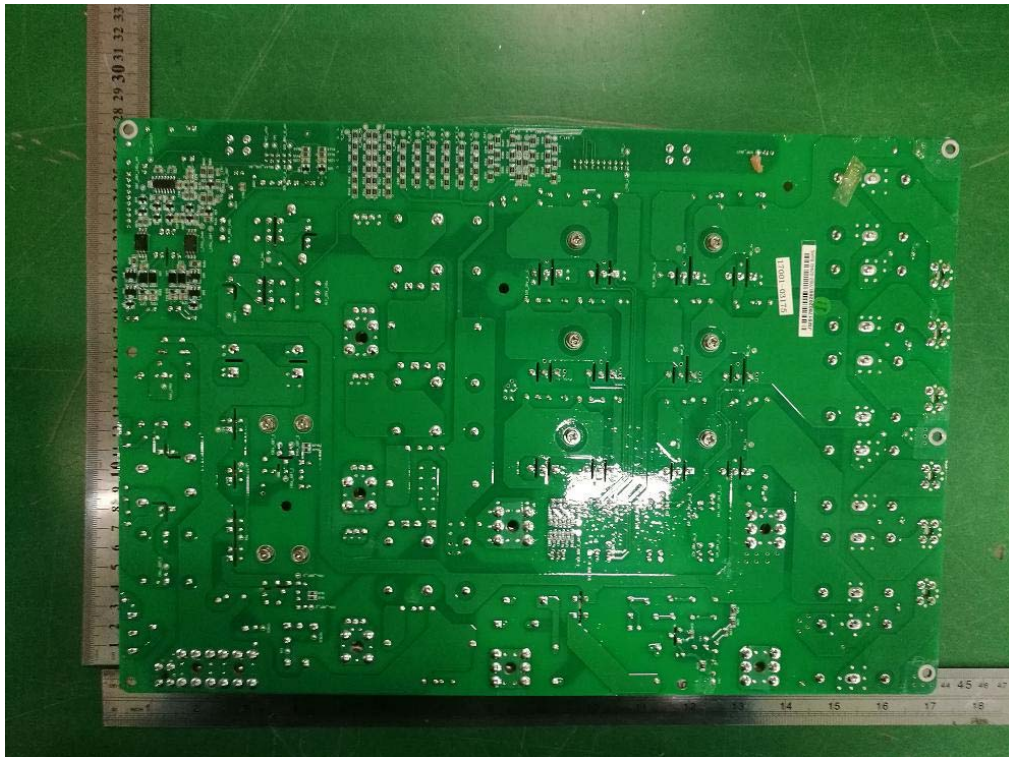

Figure 13: PCB trace view

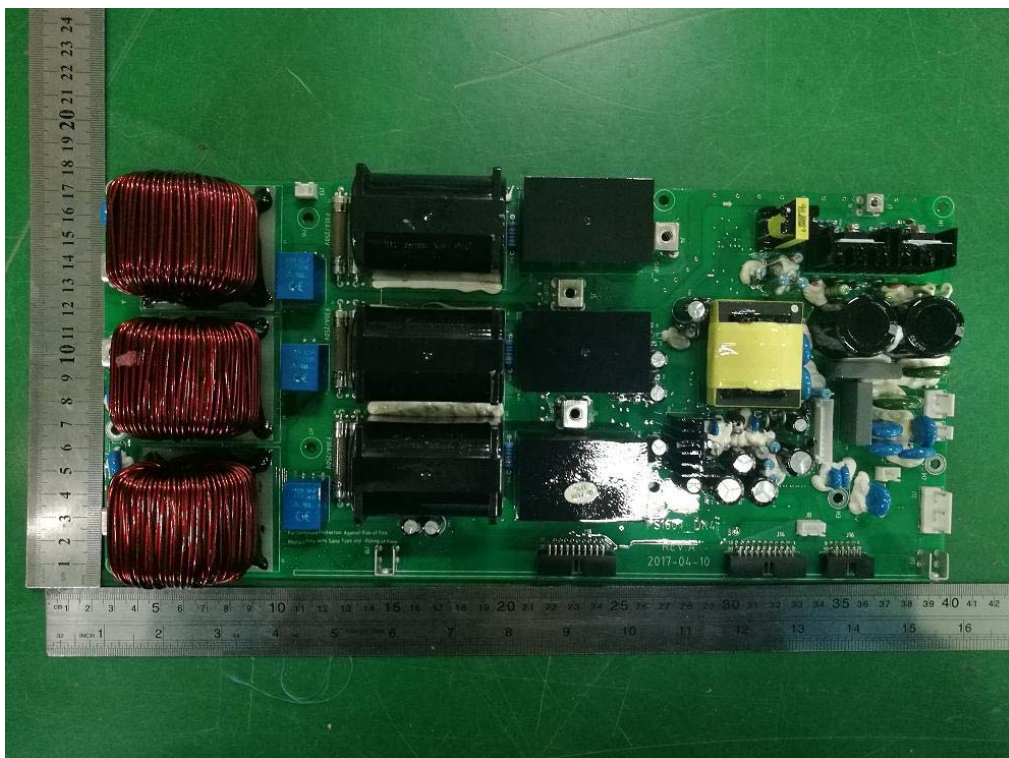

Figure 14: APS PCB component view

ATTACHMENT Photos

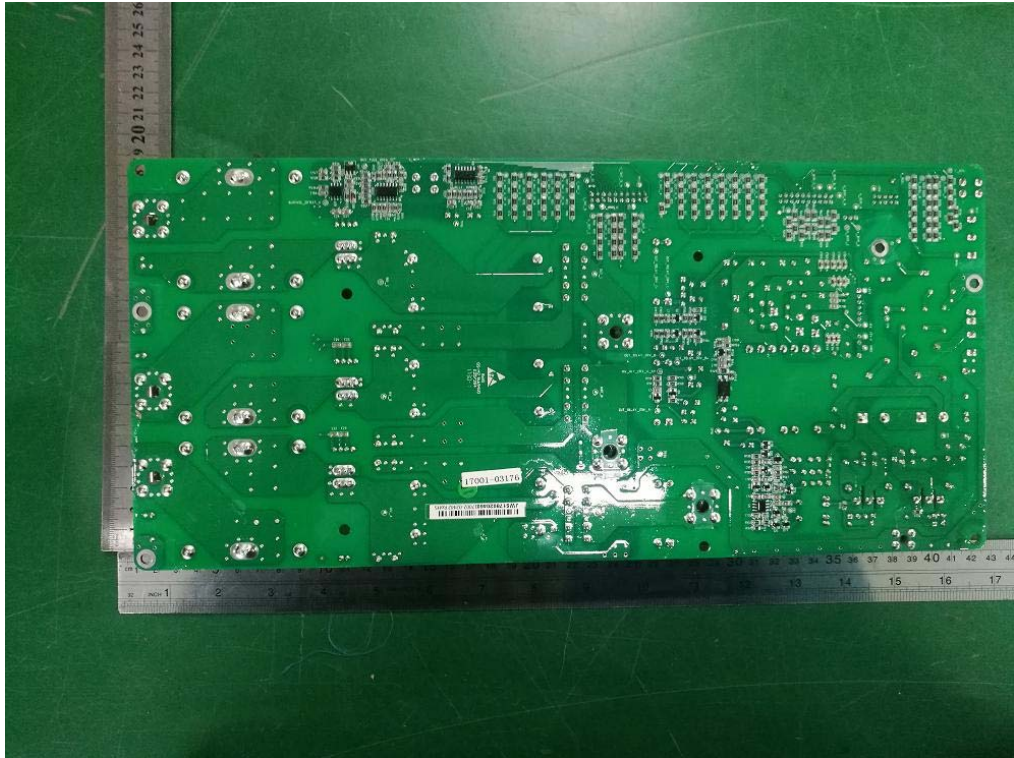

Figure 15: APS PCB trace view

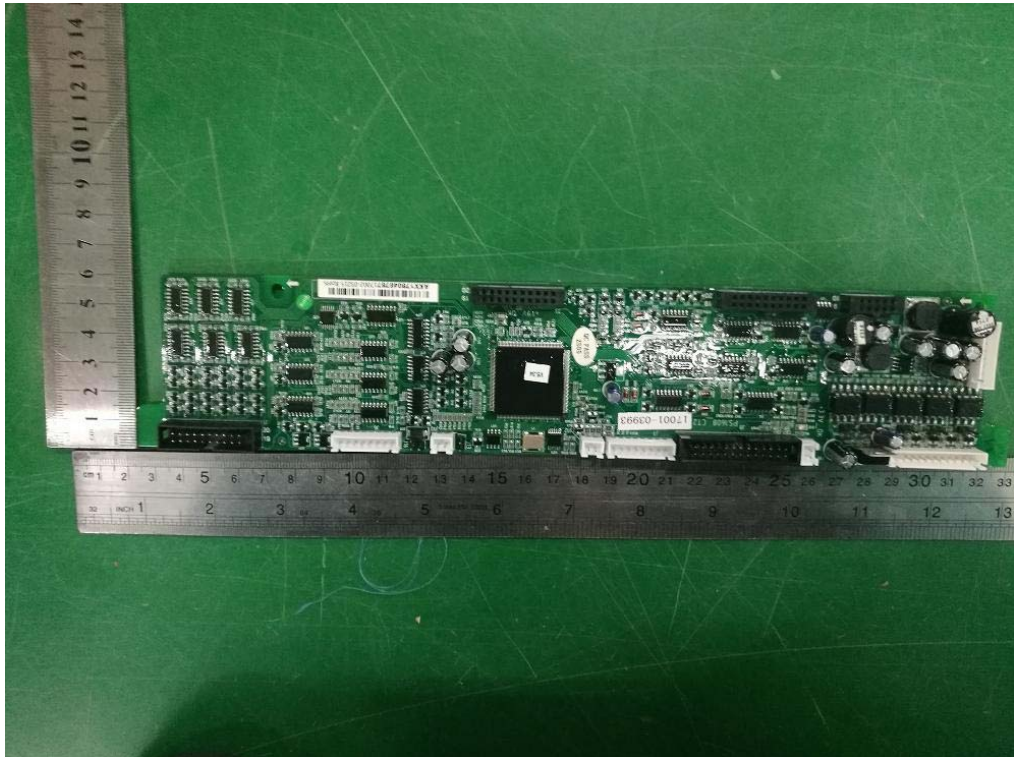

Figure 16: PCB component view

ATTACHMENT Photos

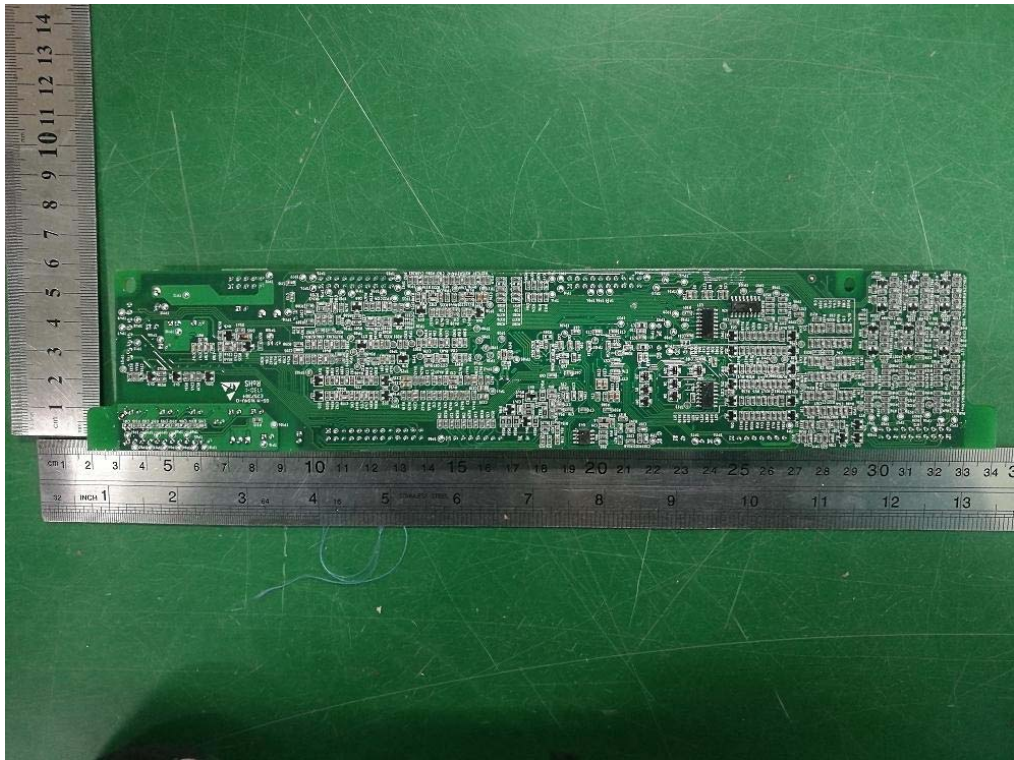

Figure 17: PCB trace view

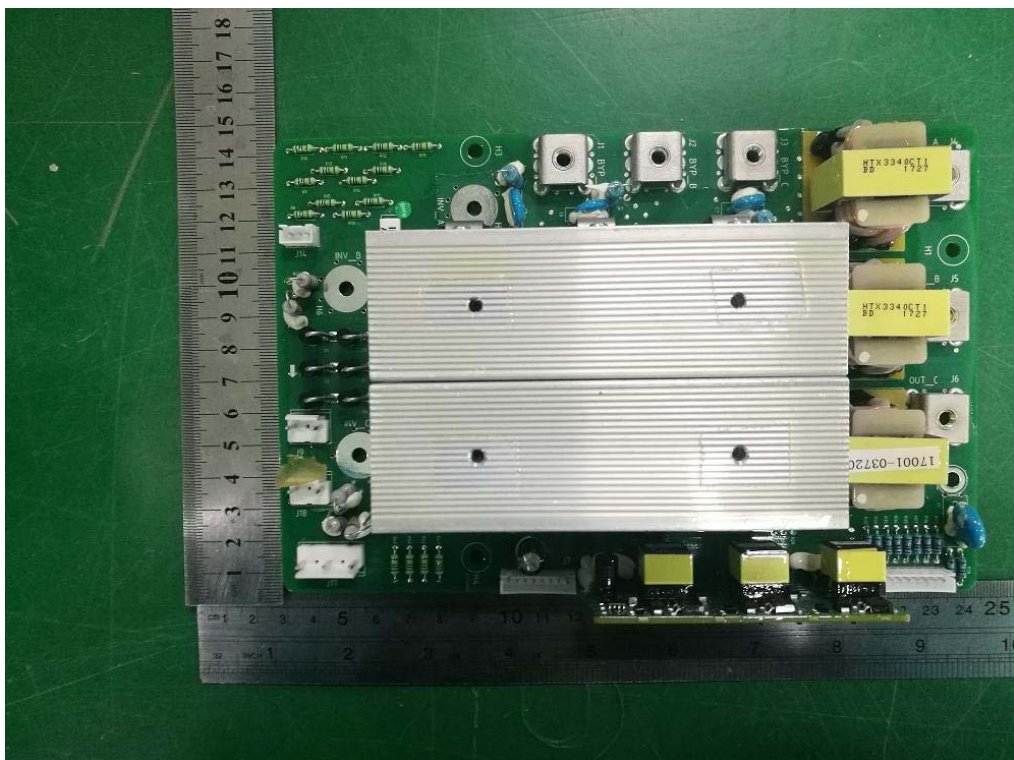

Figure 18: PCB component view



ATTACHMENT Photos

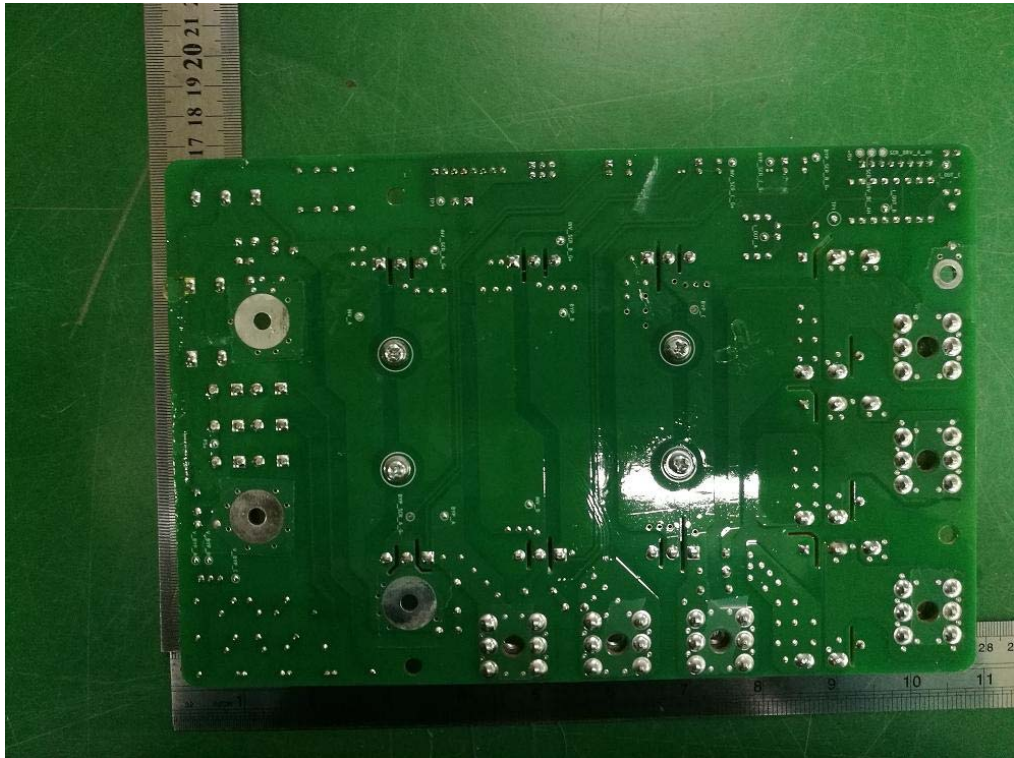

Figure 19: PCB trace view

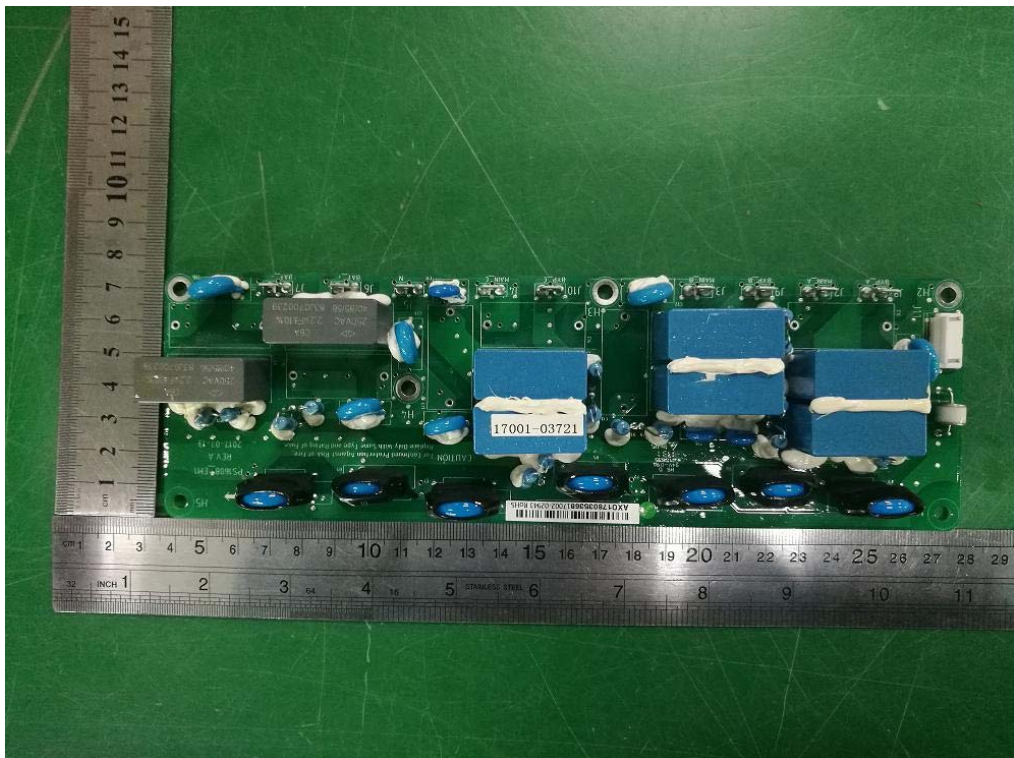

Figure 20: PCB component view

ATTACHMENT Photos

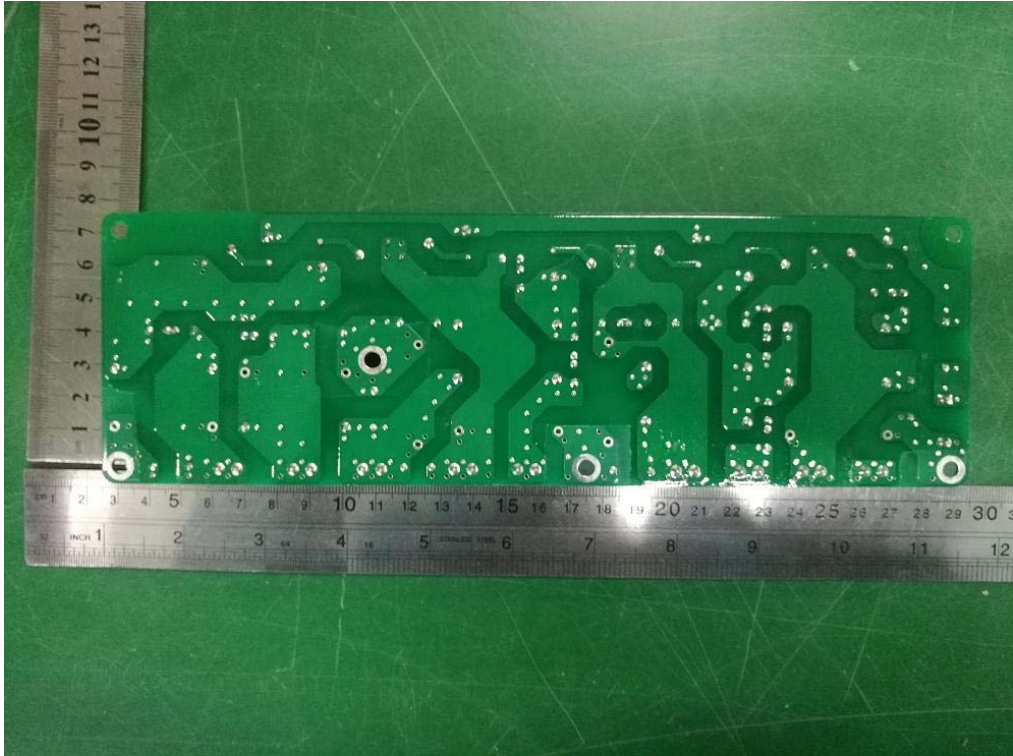

Figure 21: PCB trace view

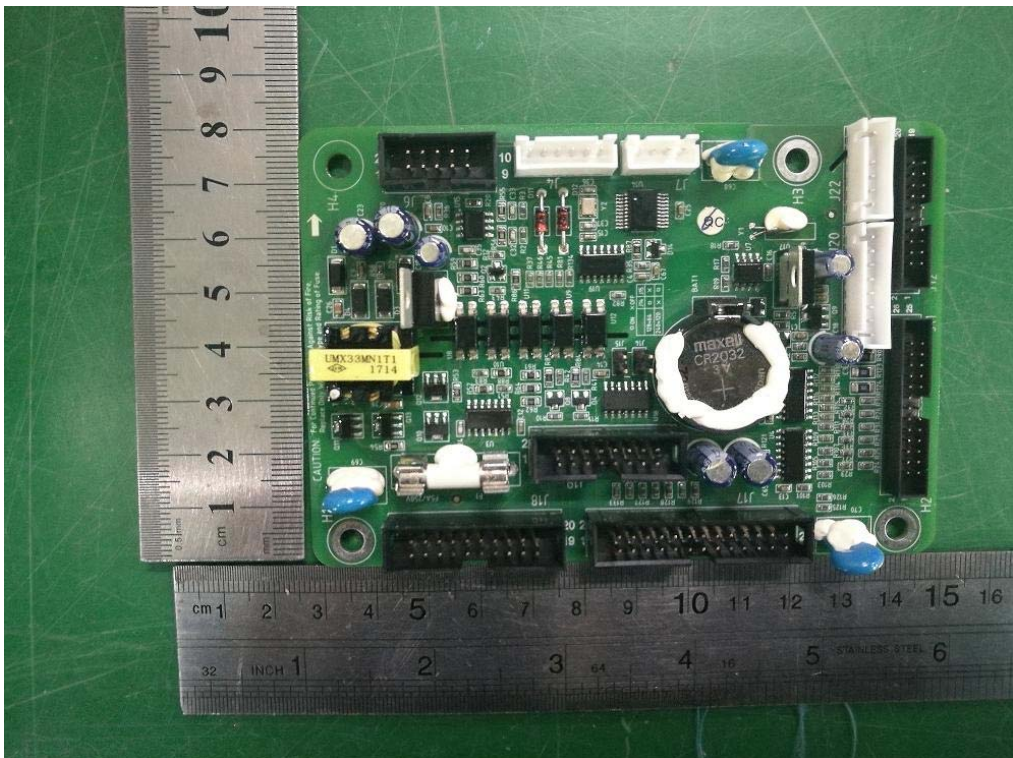

Figure 22: SELV PCB component view

ATTACHMENT Photos

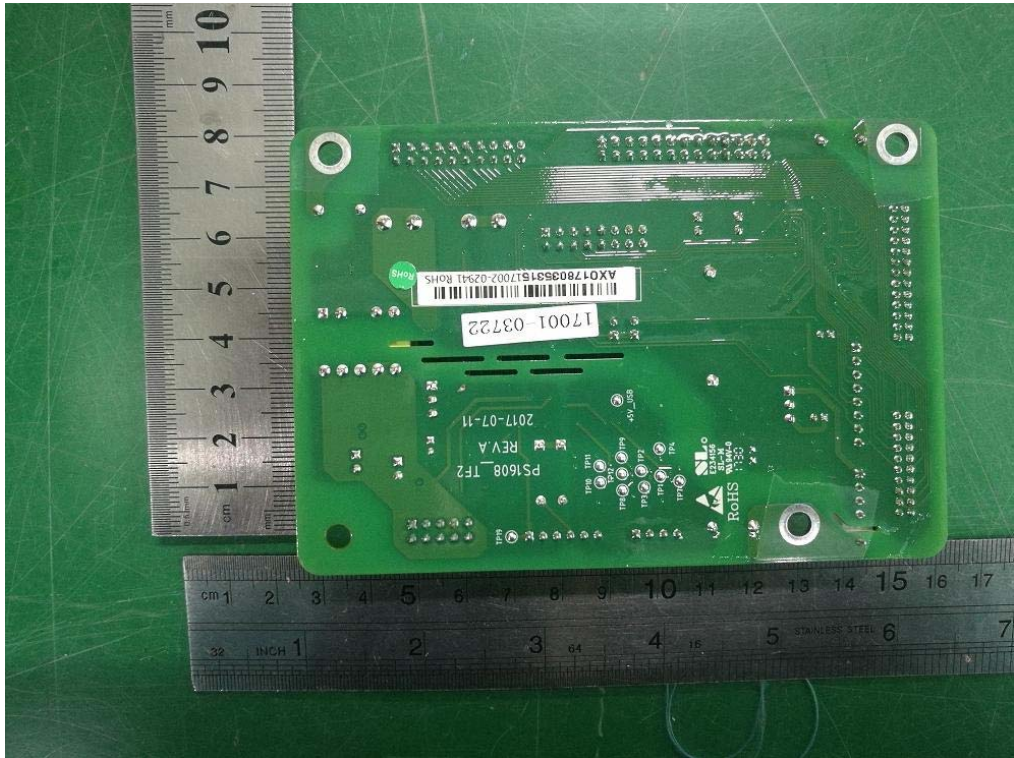

Figure 23: SELV PCB trace view

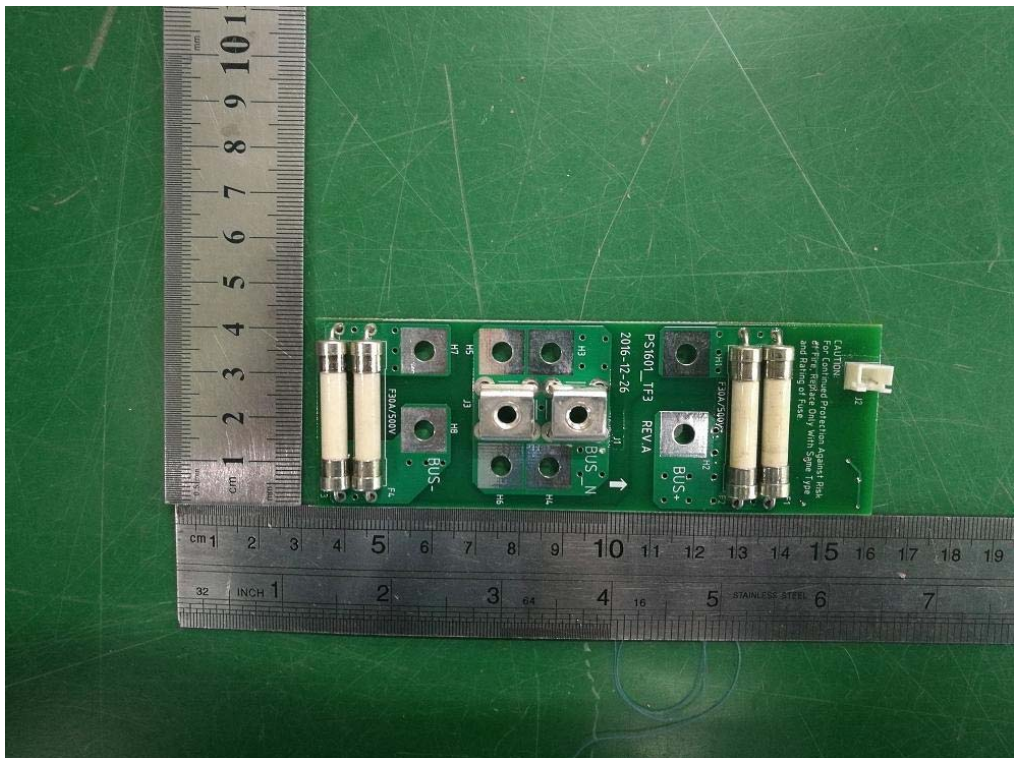

Figure 24: PCB component view

ATTACHMENT Photos

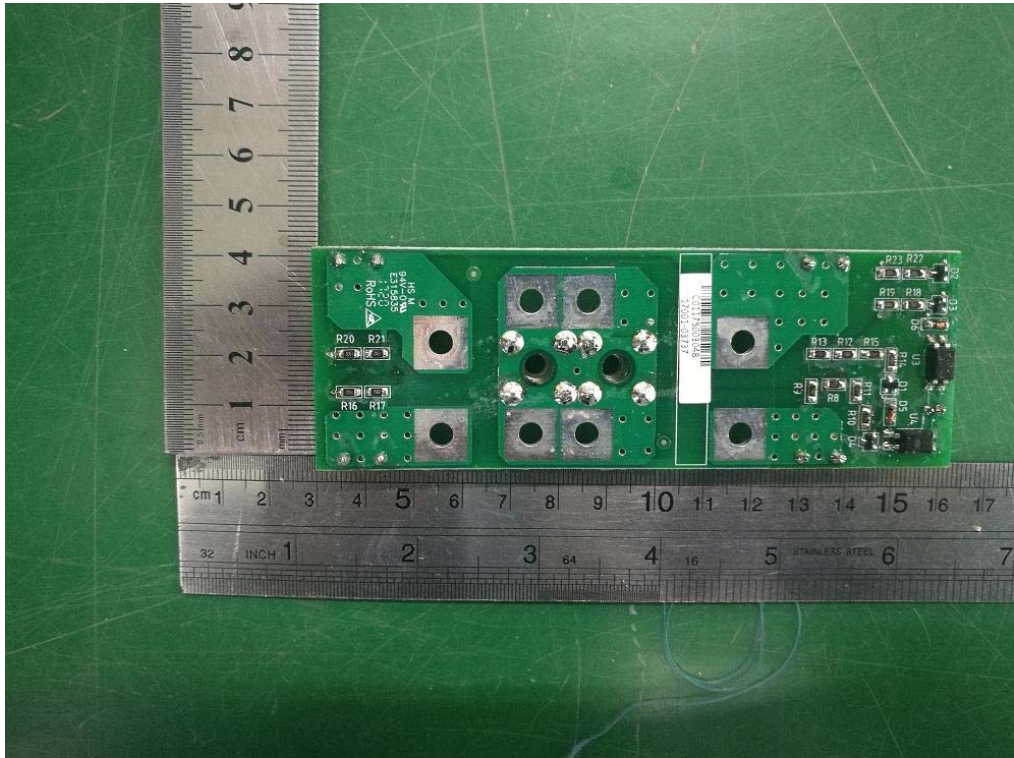

Figure 25: PCB trace view



Figure 26: PCB component view

ATTACHMENT Photos

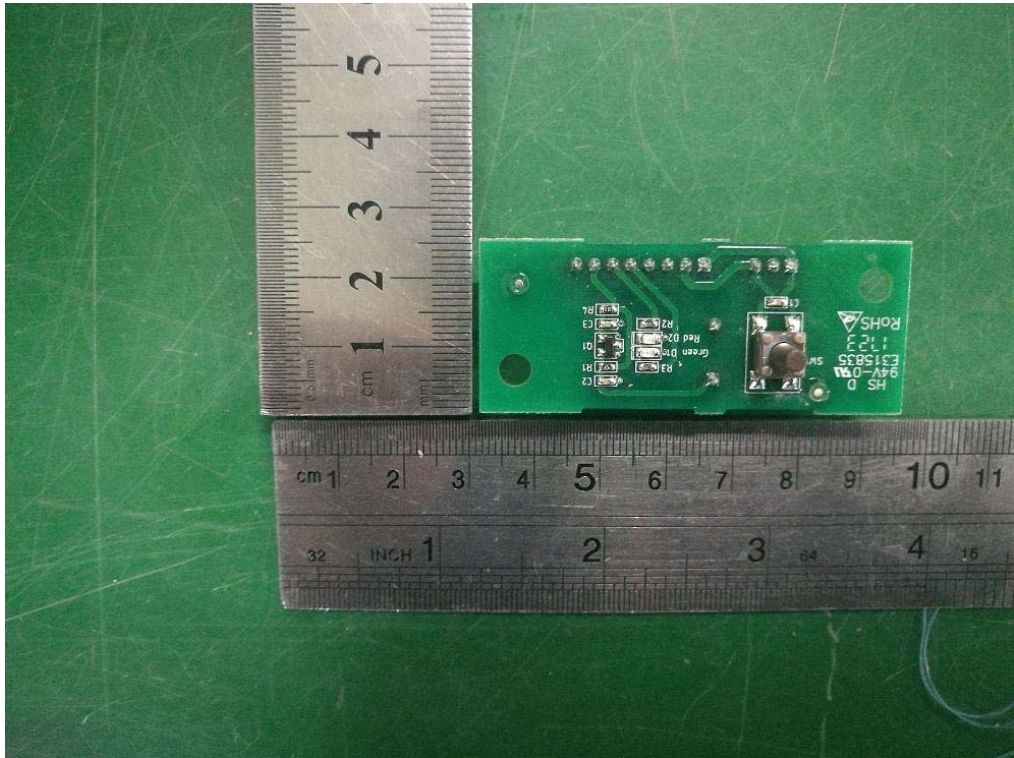

Figure 27: PCB trace view

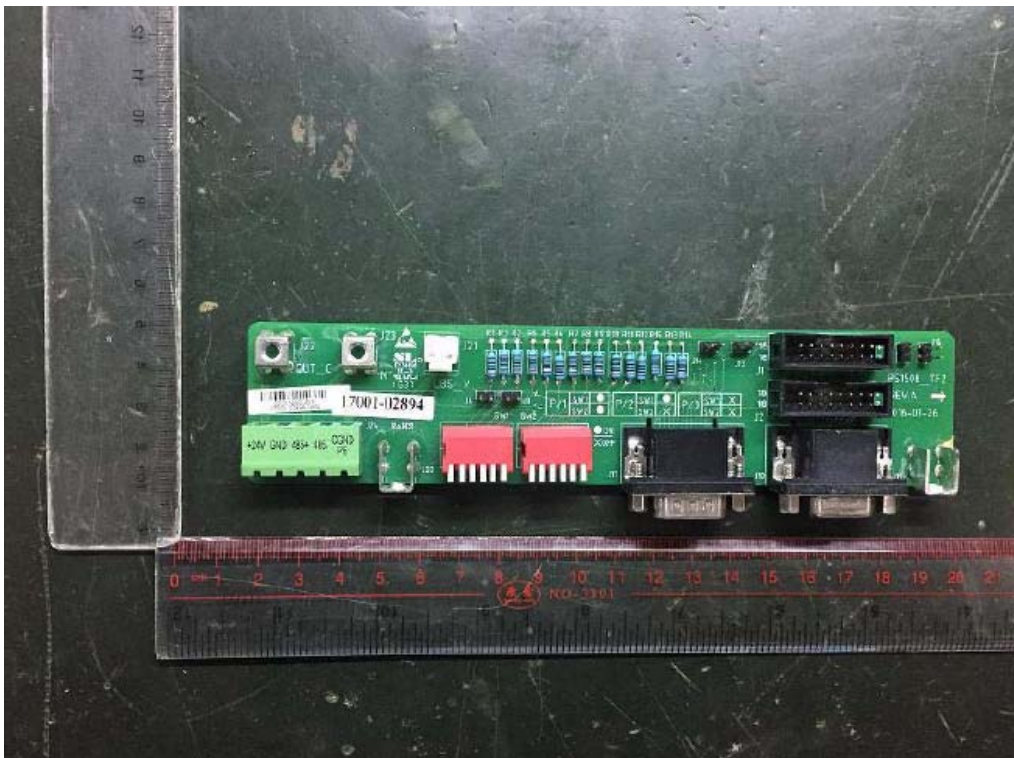

Figure 28: PCB component view

ATTACHMENT Photos

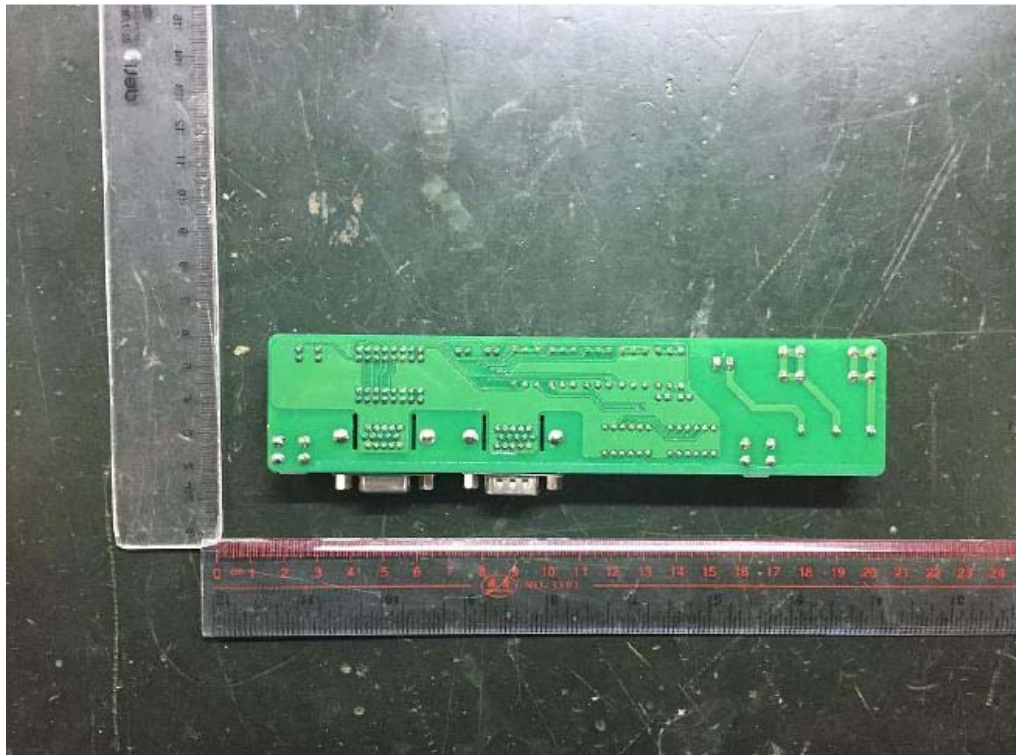

Figure 29: PCB trace view



Figure 30: PCB component view

ATTACHMENT Photos

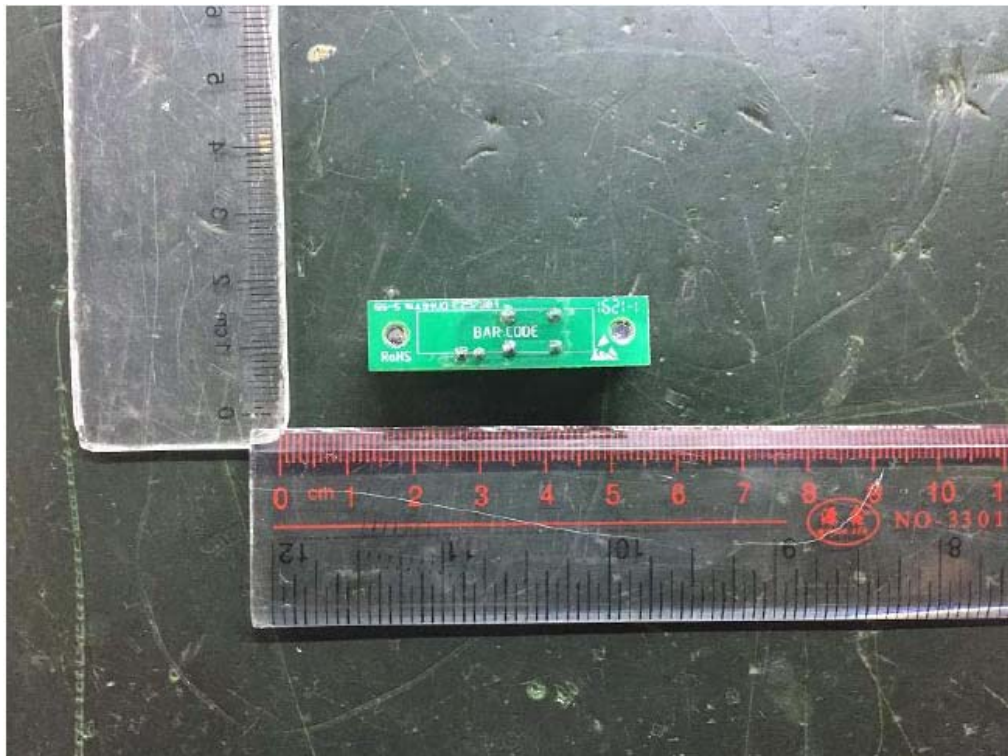

Figure 31: PCB trace view

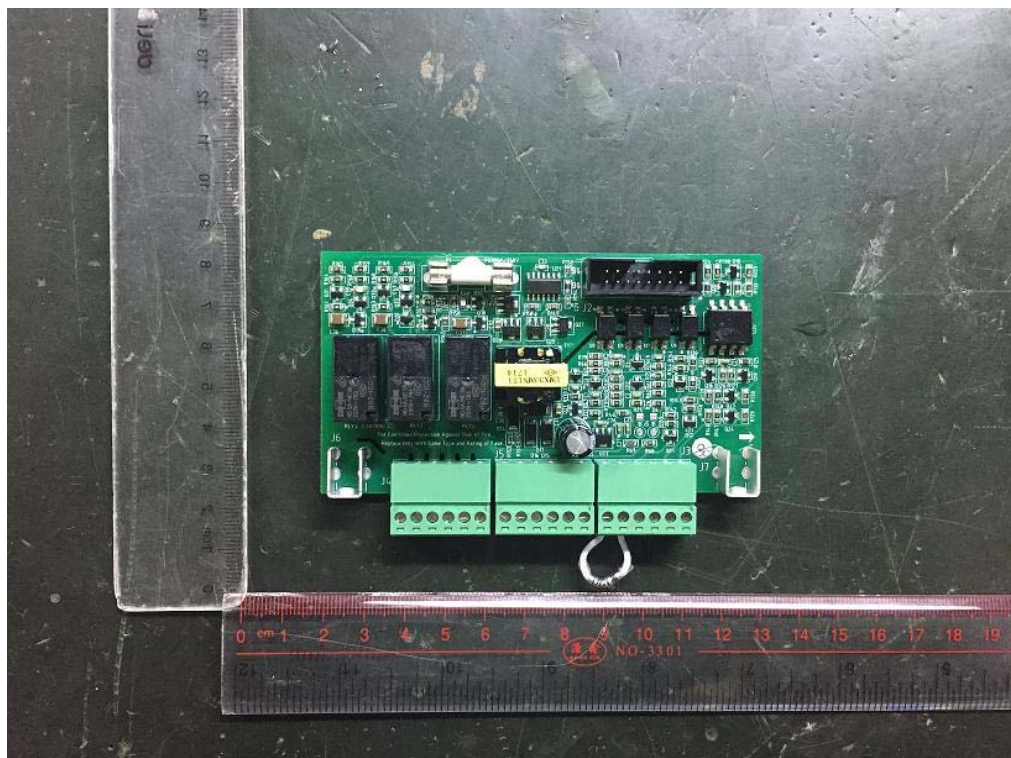

Figure 32: PCB component view

ATTACHMENT Photos

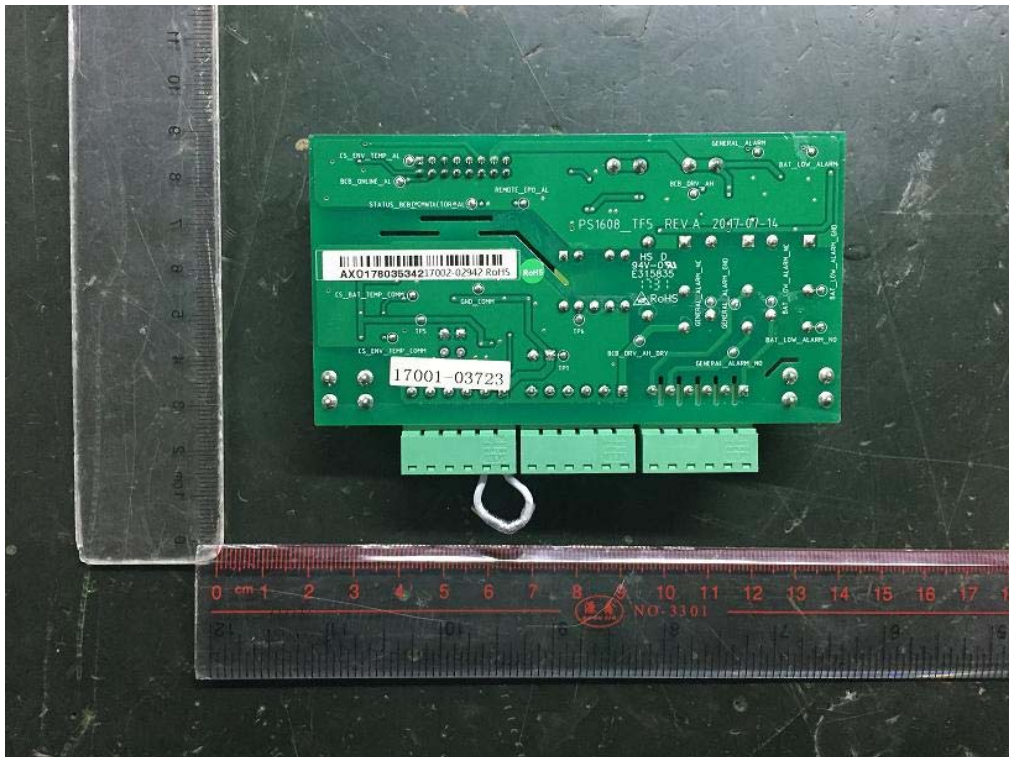

Figure 33: PCB trace view

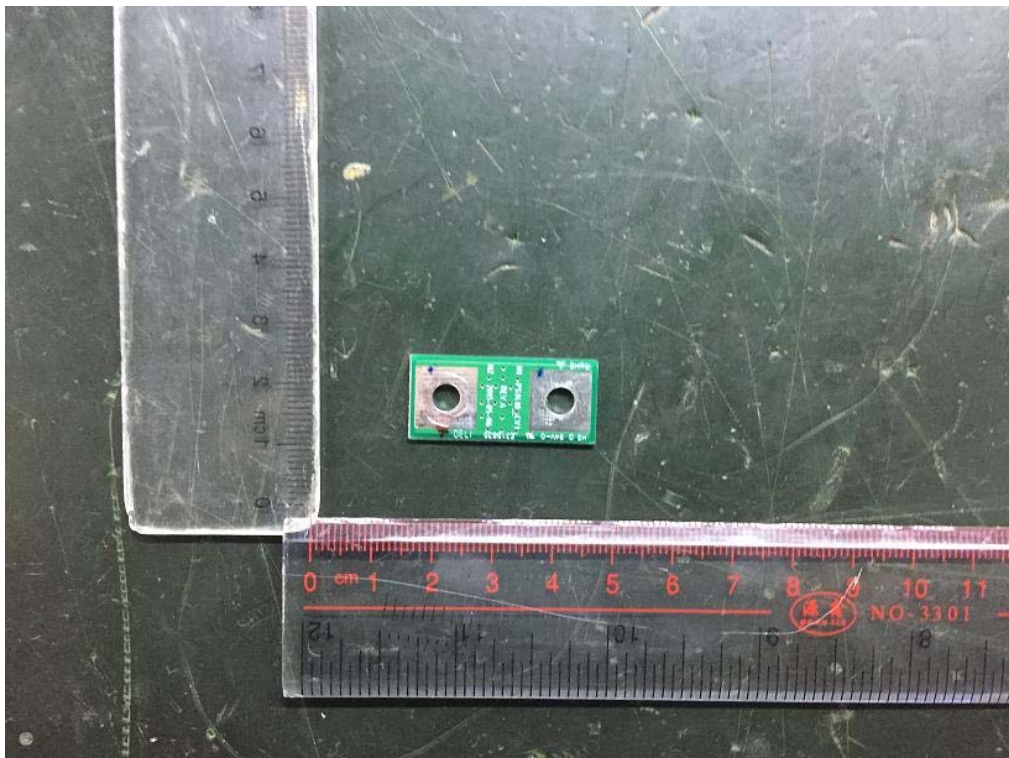

Figure 34: PCB component view



ATTACHMENT Photos

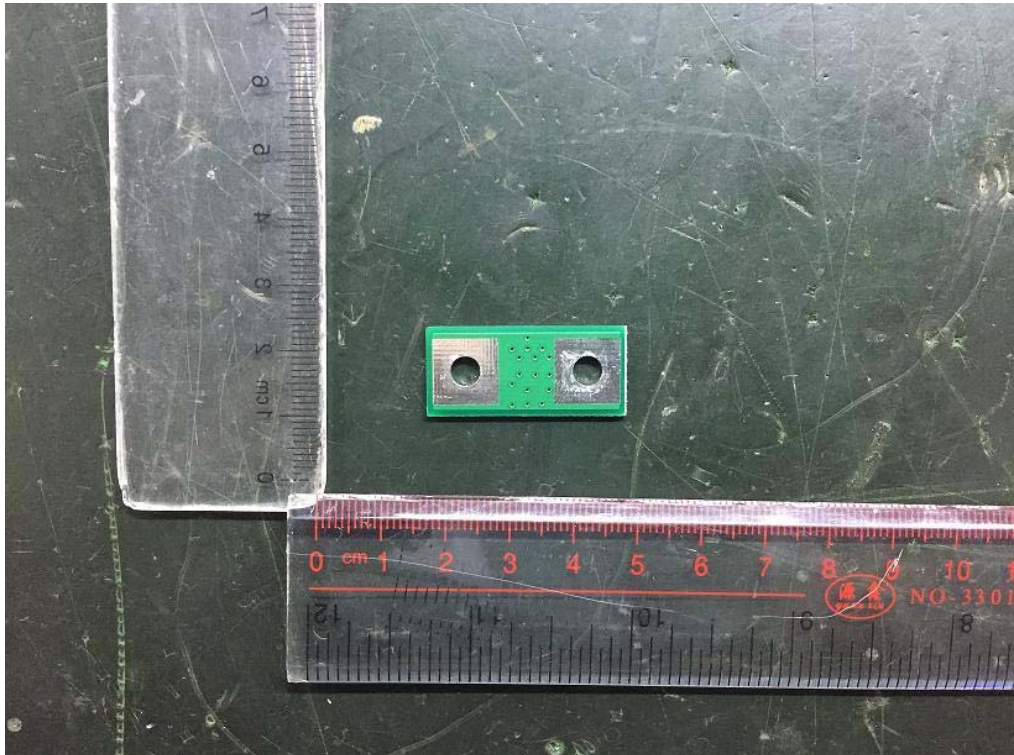

Figure 35: PCB trace view