

EMC TEST REPORT For

INVT POWER SYSTEM (SHENZHEN) CO., LTD.

Uninterruptible Power Systems

Model No.: RM040/10X, RM020/10X, PM10X, RM030/15X

Prepared for : INVT POWER SYSTEM (SHENZHEN) CO., LTD.
Address : 5th FLOOR, 1#BUILDING, GAOFA INDUSTRIAL PARK,
LONGJING, NANSHAN DISTRICT, SHENZHEN, CHINA,
518055

Prepared by : EMTEK (SHENZHEN) CO., LTD.
Address : Bldg 69, Majialong Industry Zone,
Nanshan District, Shenzhen, Guangdong, China

Tel: (0755) 26954280
Fax: (0755) 26954282

Report Number : ES160831066E
Date of Test : November 18, 2015 to December 31, 2015
Date of Report : September 01, 2016

TABLE OF CONTENT

Test Report Description	Page
1. SUMMARY OF TEST RESULT	7
2. GENERAL INFORMATION	8
2.1. Description of Device (EUT)	8
2.2. Description of Support Device	8
2.3. Description of Test Facility	9
2.4. Measurement Uncertainty	9
3. MEASURING DEVICE AND TEST EQUIPMENT	10
3.1. For Power Line Conducted Emission	10
3.2. For 10m Radiated Emission Measurement	10
3.3. For Harmonic Current / Flicker Measurement	10
3.4. For Electrostatic Discharge Immunity Test	11
3.5. For RF Strength Susceptibility Test.....	11
3.6. For Electrical Fast Transient /Burst Immunity Test	11
3.7. For Surge Immunity Test.....	12
3.8. For Injected Current Susceptibility Test	12
3.9. For Magnetic Field Immunity Test.....	12
3.10. For Voltage Dips and Interruptions Test.....	12
3.1. Low Frequency Signals Test.....	12
4. POWER LINE CONDUCTED EMISSION MEASUREMENT	13
4.1. Block Diagram of Test Setup	13
4.2. Measuring Standard.....	13
4.3. EUT Configuration on Measurement	13
4.4. Operating Condition of EUT.....	14
4.5. Test Procedure.....	14
4.6. Measuring Results	14
5. RADIATED EMISSION MEASUREMENT	31
5.1. Block Diagram of Test.....	31
5.2. Measuring Standard.....	31
5.3. Radiated Emission Limits.....	32
5.4. EUT Configuration on Test.....	32
5.5. Operating Condition of EUT.....	32
5.6. Test Procedure.....	32
5.7. Measuring Results	32
6. HARMONIC CURRENT EMISSION MEASUREMENT	41
6.1. Block Diagram of Test Setup	41
6.2. Measuring Standard.....	41
6.3. Operation Condition of EUT.....	41
6.4. Measuring Results	41
7. VOLTAGE FLUCTUATION AND FLICKER MEASUREMENT.....	42
7.1. Block Diagram of Test Setup	42
7.2. Measuring Standard.....	42
7.3. Operation Condition of EUT.....	42
7.4. Measuring Results	42
8. ELECTROSTATIC DISCHARGE IMMUNITY TEST	43
8.1. Block Diagram of Test Setup	43
8.2. Test Standard.....	43
8.3. Severity Levels and Performance Criterion	43

8.4.	EUT Configuration	43
8.5.	Operating Condition of EUT	44
8.6.	Test Procedure	44
8.7.	Test Results	44
9.	RF FIELD STRENGTH SUSCEPTIBILITY TEST	46
9.1.	Block Diagram of Test	46
9.2.	Test Standard	46
9.3.	Severity Levels and Performance Criterion	47
9.4.	EUT Configuration on Test	47
9.5.	Operating Condition of EUT	47
9.6.	Test Procedure	47
9.7.	Test Results	47
10.	ELECTRICAL FAST TRANSIENT/BURST IMMUNITY TEST	49
10.1.	Block Diagram of Test Setup	49
10.2.	Test Standard	49
10.3.	Severity Levels and Performance Criterion	49
10.4.	EUT Configuration	49
10.5.	Operating Condition of EUT	50
10.6.	Test Procedure	50
10.7.	Test Result	50
11.	SURGE IMMUNITY TEST	52
11.1.	Block Diagram of Test Setup	52
11.2.	Test Standard	52
11.3.	Severity Levels and Performance Criterion	52
11.4.	EUT Configuration	52
11.5.	Operating Condition of EUT	53
11.6.	Test Procedure	53
11.7.	Test Result	53
12.	INJECTED CURRENTS SUSCEPTIBILITY TEST	55
12.1.	Block Diagram of Test Setup	55
12.2.	Test Standard	55
12.3.	Severity Levels and Performance Criterion	55
12.4.	EUT Configuration	55
12.5.	Operating Condition of EUT	56
12.6.	Test Procedure	56
12.7.	Test Results	56
13.	MAGNETIC FIELD SUSCEPTIBILITY TEST	58
13.1.	Block Diagram of Test	58
13.2.	Test Standard	58
13.3.	Severity Levels and Performance Criterion	58
13.4.	EUT Configuration on Test	58
13.5.	Test Procedure	59
13.6.	Test Results	59
14.	VOLTAGE DIPS AND INTERRUPTIONS TEST	61
14.1.	Block Diagram of Test Setup	61
14.2.	Test Standard	61
14.3.	Severity Levels and Performance Criterion	61
14.4.	EUT Configuration	61
14.5.	Operating Condition of EUT	62
14.6.	Test Procedure	62
14.7.	Test Result	62
15.	LOW FREQUENCY SIGNALS TEST	64
15.1.	Block Diagram of Test Setup	64
15.2.	Test Standard	64
15.3.	Operating Condition of EUT	64

15.4. Test Results 64

16. PHOTOGRAPH 66

16.1. Photo of Conducted Emission Measurement 66

16.2. Photo of Radiation Emission Measurement 67

16.3. Photo of RF Field Strength Susceptibility Test..... 67

16.4. For Harmonic Current / Flicker Measurement 68

16.5. Photo of Electrostatic Discharge Test 68

16.6. Photo of RF Field Strength Susceptibility Test..... 69

16.7. Photo of Electrical Fast Transient / Burst Test..... 69

16.8. Photo of Surge Test 70

16.9. Photo of Injected Currents Susceptibility Test 70

16.10. Photo of Magnetic Field Immunity Test..... 71

16.11. Photo of Voltage Dips and Interruption Immunity Test..... 71

16.12. Photo of Low Frequency Signals Test 72

APPENDIX (Photos of EUT) (16 Page)

TEST REPORT DESCRIPTION

Applicant : INVT POWER SYSTEM (SHENZHEN) CO., LTD.
 Manufacturer : INVT POWER SYSTEM (SHENZHEN) CO., LTD.
 Trademark : INVT
 EUT : Uninterruptible Power Systems
 (A) Model No. : RM040/10X, RM020/10X, PM10X, RM030/15X
 (B) Power Supply:
 Input: 380Vac/64A, 380Vac/32A
 Output: 380Vac/60.6A, 380Vac/30.4A

Measurement Procedure Used:

EN62040-2: 2006
 EN61000-3-12: 2011,
 EN 61000-3-11: 2000
 (EN61000-4-2:2009, EN61000-4-3:2006+A1:2008+A2:2010, EN61000-4-4:2012, EN61000-4-5: 2014,
 EN61000-4-6: 2014, EN61000-4-8: 2010, EN61000-4-11: 2004, EN61000-2-2: 2006)

The device described above is tested by EMTEK (SHENZHEN) CO., LTD. to determine the maximum emission levels emanating from the device and the severe levels of the device can endure and its performance criterion. The measurement results are contained in this test report and EMTEK (SHENZHEN) CO., LTD. is assumed full of responsibility for the accuracy and completeness of these measurements. Also, this report shows that the EUT (Equipment Under Test) is technically compliant with the EN 62040-2 requirements.

This report applies to above tested sample only and shall not be reproduced in part without written approval of EMTEK (SHENZHEN) CO., LTD.

Date of Test : November 18, 2015 to December 31, 2015

Prepared by : Kevin Fan
 Kevin Fan/Editor

Reviewer : Jessie Hu
 Jessie Hu/Supervisor

Approved & Authorized Signer : Lisa Wang
 Lisa Wang/Manager

Modified Information

Version	Report No.	Revision Date	Summary
Ver.1.0	ES151030071E	/	Original Version
Ver.1.0	ES160831066E	2016/9/1	1.Updated EMC directive and standard 2.Change Model No

1. SUMMARY OF TEST RESULT

EMISSION			
Description of test item	Standard	Limits	Results
Conducted disturbance at mains terminals	EN62040-2: 2006	C3	Pass
Radiated Disturbance	EN62040-2: 2006	C3	Pass
Harmonic current emissions	EN61000-3-12:2011	-	N/A
Voltage fluctuation and flicker	EN 61000-3-11: 2000	-	N/A
Immunity			
Description of test item	Basic Standard	Performance Criteria	Results
Electrostatic Discharge (ESD)	EN61000-4-2: 2009	B	A
Radio-frequency, Continuous radiated disturbance	EN61000-4-3: 2006+A1:2008+A2:2010	A	A
EFT/B Immunity	EN61000-4-4: 2012	B	A
Surge Immunity	EN61000-4-5: 2014	B	A
Conducted RF Immunity	EN61000-4-6: 2014	A	A
Power frequency magnetic field	EN61000-4-8: 2010	A	A
Voltage dips and Voltage interruptions	EN61000-4-11:2004	A	Pass
Low Frequency signals	EN61000-2-2: 2006	A	Pass
Note: N/A is an abbreviation for Not Applicable.			

2. GENERAL INFORMATION

2.1. Description of Device (EUT)

EUT	:	Uninterruptible Power Systems
Model Number	:	RM040/10X, RM020/10X, PM10X, RM030/15X (Note: Modular uninterrupted power supply, system cabinet and power module. The cabinet is composed of a power distribution cabinet, a cabinet and a bypass module. Single power module power is 10kVA, RM040/10X can be inserted into the 4 power module, a power module can be inserted into RM020/10X 2. The two models of the system are fully consistent with a single board. We prepare RM040/10X, RM020/10X for test.)
Test Voltage	:	AC 380V/50Hz
Applicant	:	INVT POWER SYSTEM (SHENZHEN) CO., LTD.
Address	:	5 th FLOOR, 1#BUILDING, GAOFA INDUSTRIAL PARK, LONGJING, NANSHAN DISTRICT, SHENZHEN, CHINA, 518055
Manufacturer	:	INVT POWER SYSTEM (SHENZHEN) CO., LTD.
Address	:	5 th FLOOR, 1#BUILDING, GAOFA INDUSTRIAL PARK, LONGJING, NANSHAN DISTRICT, SHENZHEN, CHINA, 518055
Date of receiver	:	November 18, 2015
Date of Test	:	November 18, 2015 to December 31, 2015

2.2. Description of Support Device

N/A

2.3. Description of Test Facility

Site Description

EMC Lab. : Accredited by CNAS, 2013.10.29
The certificate is valid until 2016.10.28
The Laboratory has been assessed and proved to be in compliance with
CNAS-CL01:2006(identical to ISO/IEC17025:2005)
The Certificate Registration Number is L2291.

Accredited by TUV Rheinland Shenzhen 2010.5.25
The Laboratory has been assessed according to the requirements
ISO/IEC 17025.

Accredited by FCC, Valid until 2017/07/12
The Certificate Registration Number is 709623.

Accredited by Industry Canada, November 24, 2015
The Certificate Registration Number is 4480A.

Name of Firm : EMTEK (SHENZHEN) CO., LTD
Site Location : Bldg 69, Majialong Industry Zone,
Nanshan District, Shenzhen, Guangdong, China

2.4. Measurement Uncertainty

Test Item	Uncertainty
Conducted Emission Uncertainty	: 3.16dB(9k~150kHz Conduction 2#) 2.90dB(150k-30MHz Conduction 2#)
Power clamp	: 2.53dB
Uncertainty for Flicker test	: 0.07%
Uncertainty for Harmonic test	: 1.8%
Uncertainty for C/S Test	: 1.45(Using CDN Test)
Uncertainty for test site temperature and humidity	: 0.6°C 4%

3. MEASURING DEVICE AND TEST EQUIPMENT

3.1. For Power Line Conducted Emission

Item	Equipment	Manufacturer	Model No.	Serial No.	Last Cal.	Cal. Interval
1.	Test Receiver	Rohde & Schwarz	ESCS30	828985/018	May 16, 2015	1 Year
2.	L.I.S.N	Rohde & Schwarz	ESH2-Z5	834549/005	May 16, 2015	1 Year
3.	50Ω Coaxial Switch	Anritsu	MP59B	M20531	N/A	N/A
4.	Pulse Limiter	Rohde & Schwarz	ESH3-Z2	100006	May 16, 2015	1 Year
5.	Voltage Probe	Rohde & Schwarz	TK9416	N/A	May 16, 2015	1 Year

3.2. For 10m Radiated Emission Measurement

Item	Equipment	Manufacturer	Model No.	Serial No.	Last Cal.	Cal. Interval
1	EMI Test Receiver	Rohde & Schwarz	ESR3	1316.3003K03-101706-HN	May 16, 2015	1 Year
2	EMI Test Receiver	Rohde & Schwarz	ESR3	1316.3003K03-101707-Z1	May 16, 2015	1 Year
3	Pre-Amplifier	Lunar EM	LNA10M1G-40	J1011130912001	May 16, 2015	1 Year
4	Pre-Amplifier	Lunar EM	LNA10M1G-40	J1011131126002	May 16, 2015	1 Year
5	Bilog Antenna	Schwarzbeck	VULB9163	659	May 16, 2015	1 Year
6	Bilog Antenna	Schwarzbeck	VULB9163	661	May 16, 2015	1 Year
7	Cable	Times Microwave	LMR-240 N-N 1m	SS26-P1	May 16, 2015	1 Year
8	Cable	Times Microwave	LMR-240 N-N 1m	SS26-P2	May 16, 2015	1 Year
9	Cable	Times Microwave	LMR-240 N-N 1.5m	N/A	May 16, 2015	1 Year
10	Cable	Times Microwave	LMR-240 N-N 1.5m	N/A	May 16, 2015	1 Year
11	Cable	Times Microwave	LMR-240 N-N 12m	N/A	May 16, 2015	1 Year
12	Cable	Times Microwave	LMR-240 N-N 11m	N/A	May 16, 2015	1 Year

3.3. For Harmonic Current / Flicker Measurement

Item	Equipment	Manufacturer	Model No.	Serial No.	Last Cal.	Cal. Interval
1	Power Source	California Instruments	5001IX-CT S-400-413	N/A	May 16, 2015	1 Year
2	Harmoniv Flicker test system	California Instruments	PACS-1	1413A02055	May 16, 2015	1 Year

3.4. For Electrostatic Discharge Immunity Test

Item	Equipment	Manufacturer	Model No.	Serial No.	Last Cal.	Cal. Interval
1	ESD Tester	TESEQ AG	NSG 438A	130	May 16, 2015	1 Year
2	Impulse Module	TESEQ AG	IN NSG 438A A 4380-150p F/330Ohm	403-550/1712	May 16, 2015	1 Year
3	Impulse Module	TESEQ AG	INA 4553-330p F/330Ohm	403-588/1912	May 16, 2015	1 Year
4	Impulse Module	TESEQ AG	INA 4381-150p F/2kOhm	403-564/1812	May 16, 2015	1 Year
5	Impulse Module	TESEQ AG	INA 4382-330p F/2kOhm	403-565/1912	May 16, 2015	1 Year

3.5. For RF Strength Susceptibility Test

Item	Equipment	Manufacturer	Model No.	Serial No.	Last Cal.	Cal. Interval
1	Signal Generator	Agilent	N5181A	MY50145187	May 16, 2015	1 Year
2	RF Power Meter. Dual Channel	BOONTON	4232A	10539	May 16, 2015	1 Year
3	50ohm Diode Power Sensor	BOONTON	51011EMC	34236/34238	May 16, 2015	1 Year
4	Field Strength Meter	DARE	RSS1006A	10I00037SO2 2	May 16, 2015	1 Year
5	50ohm Diode Power Sensor	BOONTON	51011EMC	36164	May 16, 2015	1 Year
6	Power Amplifier	MILMEGA	80RF1000-175	1059345	May 16, 2015	1 Year
7	Power Amplifier	MILMEGA	AS0102-55	1018770	May 16, 2015	1 Year
8	Power Amplifier	MILMEGA	AS1860-50	1059346	May 16, 2015	1 Year
9	Log.-Per. Antenna	SCHWARZB ECK	VULP 9118E	811	May 16, 2015	1 Year
10	Broad-Band Horn Antenna	SCHWARZB ECK	STLP 9149	9149-227	May 16, 2015	1 Year
11	Multi-function interface system	DARE	CTR1009B	12I00250SNO 72	N/A	N/A
12	Automatic switch group	DARE	RSW1004A	N/A	N/A	N/A

3.6. For Electrical Fast Transient /Burst Immunity Test

Item	Equipment	Manufacturer	Model No.	Serial No.	Last Cal.	Cal. Interval
1	Burst Tester	HAEFELY	PEFT4010	080981-16	May 16, 2015	1Year
2	Coupling Clamp	HAEFELY	IP-4A	147147	May 16, 2015	1Year
3	Three phase CDN	Teseq	CDN 163	202	May 16, 2015	1 Year

3.7. For Surge Immunity Test

Item	Equipment	Manufacturer	Model No.	Serial No.	Last Cal.	Cal. Interval
1	Surge Controller	HAEFELY	Psurge 8000	174031	May 16, 2015	1Year
2	Impulse Module	HAEFELY	PIM 100	174124	May 16, 2015	1Year
3	Coupling Decoupling Filter	HAEFELY	PCD 130	172181	May 16, 2015	1Year
4	Coupling Module	HAEFELY	PCD122	174354	May 16, 2015	1Year
5	Surge Impulse Module	HAEFELY	PIM 120	174435	May 16, 2015	1Year
6	Coupling Module	HAEFELY	PCD 126A	174387	May 16, 2015	1Year
7	Impulse Module	HAEFELY	PIM 110	174391	May 16, 2015	1Year
8	Impulse Module	HAEFELY	PIM 150	178707	May 16, 2015	1Year

3.8. For Injected Current Susceptibility Test

Equ.No.	Equipment	Manufacturer	Model No.	Serial No.	Last Cal.	Cal. Interval
1	Simulator	FRANKONIA	CIT-10	126B12101201 2	May 16, 2015	1Year
2	CDN	EMTEST	CDN-M2	5100100100	May 16, 2015	1Year
3	CDN	EMTEST	CDN-M3	0900-11	May 16, 2015	1Year
4	Injection Clamp	EMTEST	F-2031-23MM	368	May 16, 2015	1Year
5	Attenuator	EMTEST	ATT6	0010222A	May 16, 2015	1Year
6	Three phase CDN	Teseq	CDN M332S	32655	May 16, 2015	1 Year
7	Three phase CDN	Teseq	CDN M432S	33670	May 16, 2015	1 Year
8	Three phase CDN	Teseq	CDN M432-3LNS	34048	May 16, 2015	1 Year
9	Three phase CDN	Teseq	CDN M532S	33799	May 16, 2015	1 Year
10	Bulk Current Injection Probe	FCC	F-120-9	140302	May 16, 2015	1 Year

3.9. For Magnetic Field Immunity Test

Item	Equipment	Manufacturer	Model No.	Serial No.	Last Cal.	Cal. Interval
1.	Magnetic Field Tester	HAEFELY	MAG100	250040.1	May 16, 2015	1Year

3.10. For Voltage Dips and Interruptions Test

Item	Equipment	Manufacturer	Model No.	Serial No.	Last Cal.	Cal. Interval
1.	Dips Tester	HAEFELY	Pline1610	083732-12	May 16, 2015	1Year

3.11. Low Frequency Signals Test

Item	Equipment	Manufacturer	Model No.	Serial No.	Last Cal.	Cal. Interval
1.	Programmable AC Source	CHROMA	6530	/	May 16, 2015	1Year

4. POWER LINE CONDUCTED EMISSION MEASUREMENT

4.1. Block Diagram of Test Setup

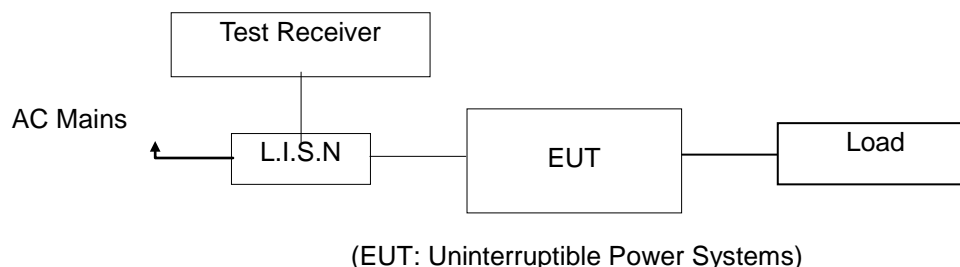

4.2. Measuring Standard

EN62040-2: 2006 Category C3

Power Line Conducted Emission Limits (C3)

UPS rated output current A	Frequency range MHz	Limits dB (μ V)	
		Quasi-peak	Average
>16 – 100	0,15 to 0,50 ^b	100	90
	0,50 to 5,0 ^b	86	76
	5,0 to 30,0	90 to 70 ^a	80 to 60 ^a
>100	0,15 to 0,50 ^b	130	120
	0,50 to 5,0 ^b	125	115
	5,0 to 30,0	115	105

^a The limits decrease linearly with the logarithm of the frequency.
^b The lower limit shall apply at the transition frequency.

4.3. EUT Configuration on Measurement

The following equipments are installed on Conducted Emission Measurement to meet EN62040-2 requirements and operating in a manner which tends to maximize its emission characteristics in a normal application.

EUT : Uninterruptible Power Systems
 Model Number : RM040/10X, RM020/10X
 Serial Number : N/A

4.4. Operating Condition of EUT

- 4.4.1. Setup the EUT as shown on Section 4.1.
- 4.4.2. Turn on the power of all equipments.
- 4.4.3. Let the EUT work in measuring mode (Line mode/Battery mode) and measure it.

4.5. Test Procedure

The EUT is put on the plane 0.8m high above the ground by insulating support and connected to the AC mains through Line Impedance Stability Network (L.I.S.N). This provided a 50ohm coupling impedance for the tested equipments. Both sides of AC line are investigated to find out the maximum conducted emission according to the EN62040-2 regulations during conducted emission measurement.

The bandwidth of the field strength meter (R&S Test Receiver ESCS30) is set at 9KHz in 150KHz~30MHz and 200Hz in 9KHz~150KHz.

The frequency range from 150kHz to 30MHz is investigated
All the scanning waveform is put in Appendix I.

4.6. Measuring Results

PASS.

Please reference to the following page.

RM040/10X

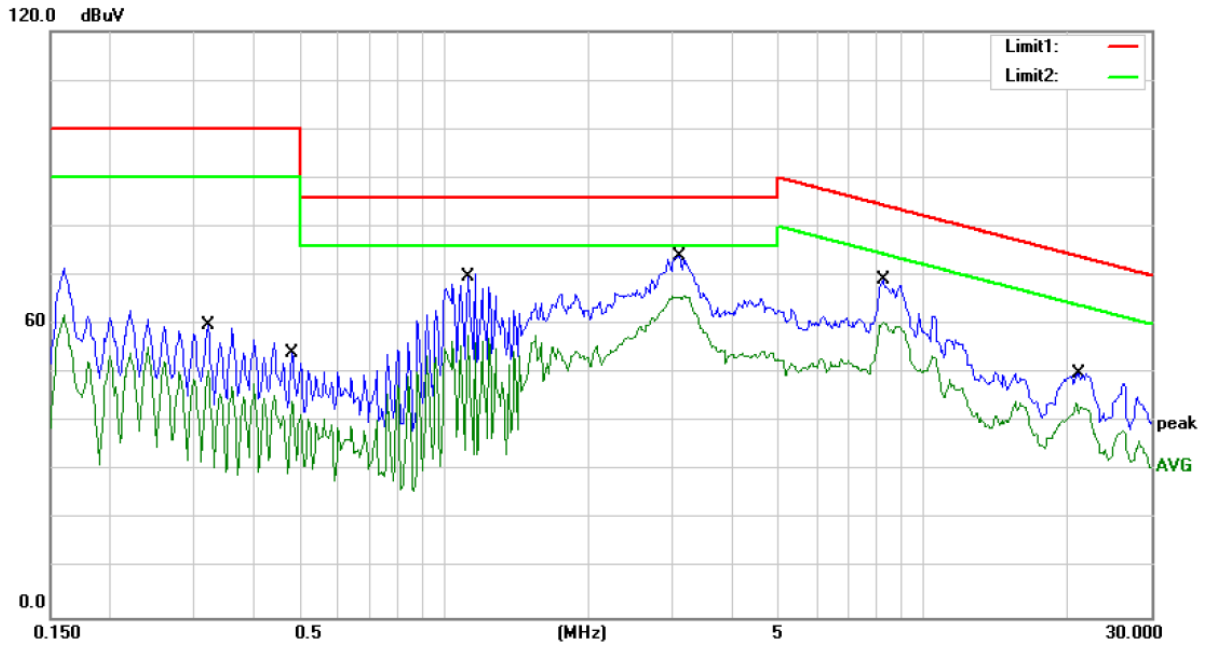

Site Conduction #2

Phase: **N**

Temperature: 26

Limit: (CE)EN62040-2 C3_QP

Power: AC 380V

Humidity: 55 %

Mode: LINE MODE

Note:

No.	Mk.	Freq.	Reading Level	Correct Factor	Measurement	Limit	Over	Detector	Comment
		MHz	dBuV	dB	dBuV	dBuV	dB		
1		0.3200	59.72	0.00	59.72	100.00	-40.28	QP	
2		0.3200	50.53	0.00	50.53	90.00	-39.47	AVG	
3		0.4800	54.30	0.00	54.30	100.00	-45.70	QP	
4		0.4800	40.54	0.00	40.54	90.00	-49.46	AVG	
5		1.1200	69.86	0.00	69.86	86.00	-16.14	QP	
6		1.1200	57.87	0.00	57.87	76.00	-18.13	AVG	
7		3.0901	73.91	0.00	73.91	86.00	-12.09	QP	
8	*	3.0901	65.92	0.00	65.92	76.00	-10.08	AVG	
9		8.2400	69.24	0.00	69.24	84.42	-15.18	QP	
10		8.2400	60.44	0.00	60.44	74.42	-13.98	AVG	
11		20.8750	50.09	0.00	50.09	74.05	-23.96	QP	
12		20.8750	43.90	0.00	43.90	64.05	-20.15	AVG	

*:Maximum data x:Over limit !:over margin Comment: Factor build in receiver. Operator: HJ

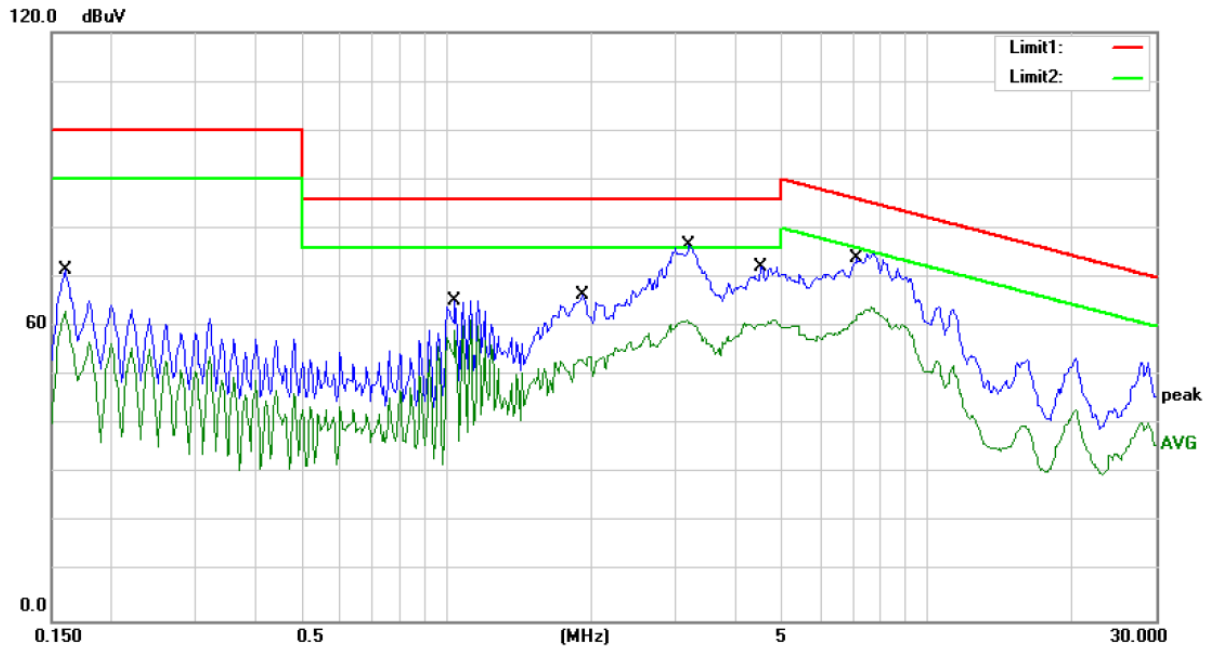

Site Conduction #2

Phase: **L1**

Temperature: 26

Limit: (CE)EN62040-2 C3_QP

Power: AC 380V

Humidity: 55 %

Mode: LINE MODE

Note:

No.	Mk.	Freq.	Reading Level	Correct Factor	Measurement	Limit	Over	Detector	Comment
		MHz	dBuV	dB	dBuV	dBuV	dB		
1		0.1600	71.55	0.00	71.55	100.00	-28.45	QP	
2		0.1600	63.19	0.00	63.19	90.00	-26.81	AVG	
3		1.0400	65.36	0.00	65.36	86.00	-20.64	QP	
4		1.0400	61.34	0.00	61.34	76.00	-14.66	AVG	
5		1.9200	66.57	0.00	66.57	86.00	-19.43	QP	
6		1.9200	56.50	0.00	56.50	76.00	-19.50	AVG	
7	*	3.1600	76.57	0.00	76.57	86.00	-9.43	QP	
8		3.1600	61.22	0.00	61.22	76.00	-14.78	AVG	
9		4.5200	72.29	0.00	72.29	86.00	-13.71	QP	
10		4.5200	61.38	0.00	61.38	76.00	-14.62	AVG	
11		7.1600	73.86	0.00	73.86	85.99	-12.13	QP	
12		7.1600	63.94	0.00	63.94	75.99	-12.05	AVG	

*:Maximum data x:Over limit !:over margin Comment: Factor build in receiver. Operator: HJ

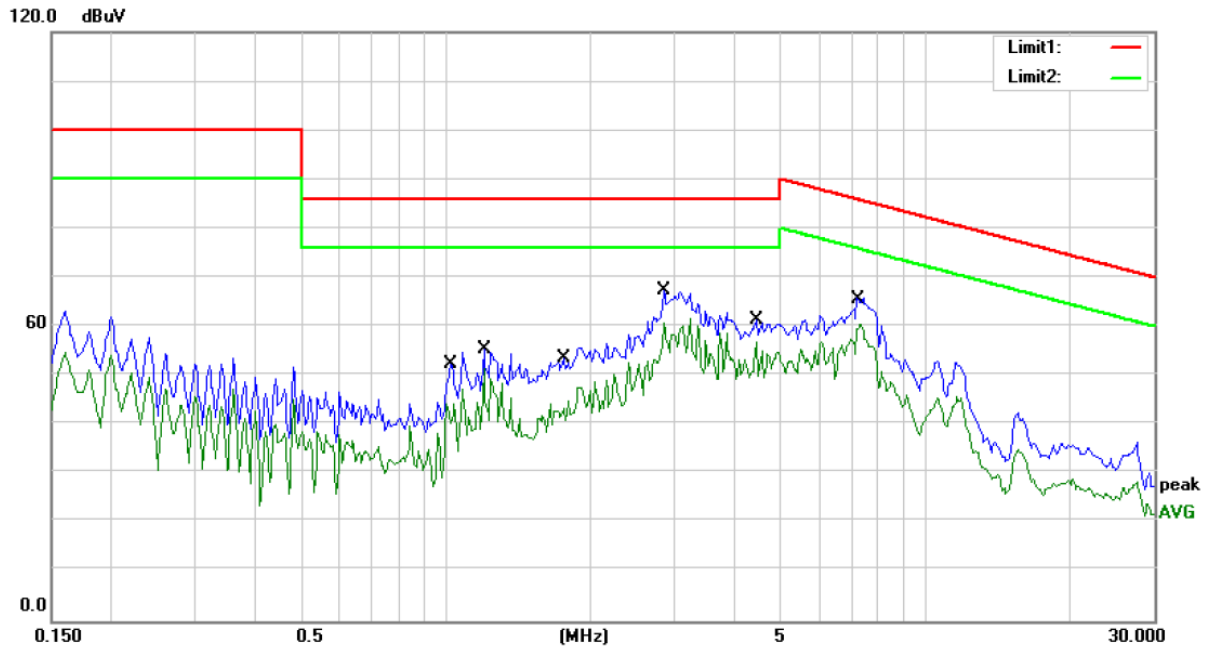

Site Conduction #2

Phase: **L2**

Temperature: 26

Limit: (CE)EN62040-2 C3_QP

Power: AC 380V

Humidity: 55 %

Mode: LINE MODE

Note:

No.	Mk.	Freq.	Reading Level	Correct Factor	Measurement	Limit	Over	Detector	Comment
		MHz	dBuV	dB	dBuV	dBuV	dB		
1		1.0250	52.43	0.00	52.43	86.00	-33.57	QP	
2		1.0250	47.33	0.00	47.33	76.00	-28.67	AVG	
3		1.2000	55.38	0.00	55.38	86.00	-30.62	QP	
4		1.2000	48.81	0.00	48.81	76.00	-27.19	AVG	
5		1.7600	53.68	0.00	53.68	86.00	-32.32	QP	
6		1.7600	47.48	0.00	47.48	76.00	-28.52	AVG	
7		2.8400	67.20	0.00	67.20	86.00	-18.80	QP	
8		2.8400	60.65	0.00	60.65	76.00	-15.35	AVG	
9		4.4400	61.34	0.00	61.34	86.00	-24.66	QP	
10		4.4400	56.82	0.00	56.82	76.00	-19.18	AVG	
11		7.3200	65.90	0.00	65.90	85.75	-19.85	QP	
12	*	7.3200	60.41	0.00	60.41	75.75	-15.34	AVG	

*:Maximum data x:Over limit !:over margin Comment: Factor build in receiver. Operator: HJ

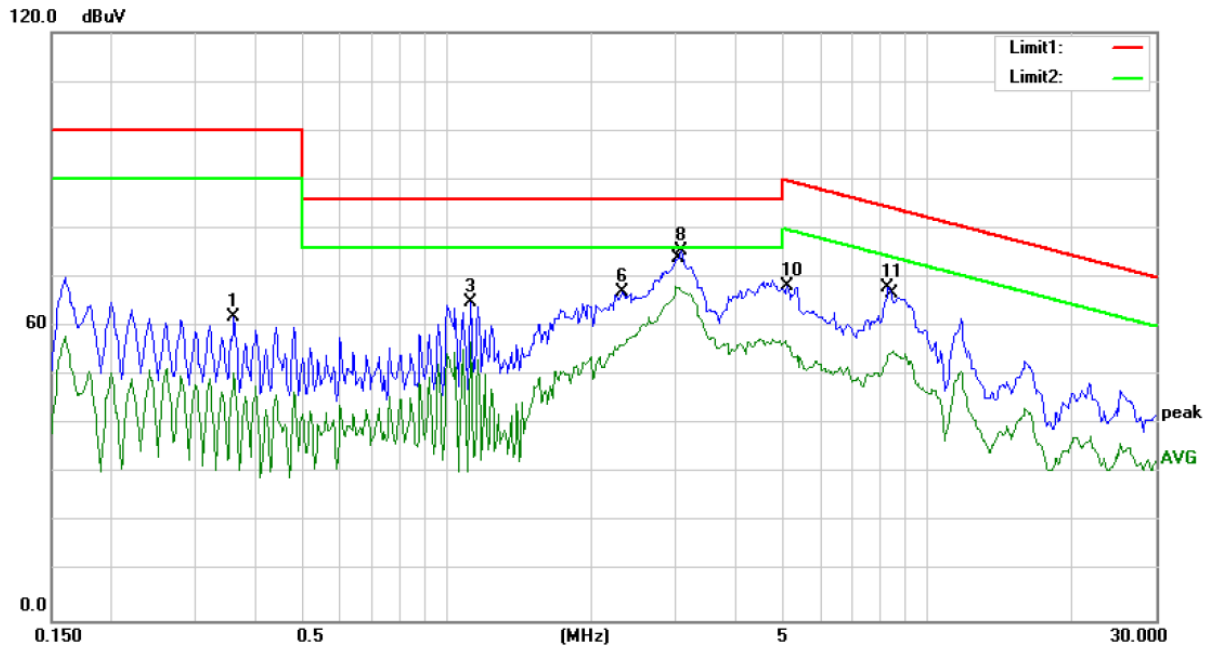

Site Conduction #2

Phase: **L3**

Temperature: 26

Limit: (CE)EN62040-2 C3_QP

Power: AC 380V

Humidity: 55 %

Mode: LINE MODE

Note:

No.	Mk.	Freq. MHz	Reading Level dBuV	Correct Factor dB	Measure- ment dBuV	Limit dBuV	Over dB	Detector	Comment
1		0.3600	61.92	0.00	61.92	100.00	-38.08	peak	
2		0.3600	50.49	0.00	50.49	90.00	-39.51	AVG	
3		1.1200	65.10	0.00	65.10	86.00	-20.90	peak	
4		1.1200	56.87	0.00	56.87	76.00	-19.13	AVG	
5		2.2845	56.36	0.00	56.36	76.00	-19.64	AVG	
6		2.3200	67.17	0.00	67.17	86.00	-18.83	peak	
7	*	3.0000	68.25	0.00	68.25	76.00	-7.75	AVG	
8		3.0800	75.55	0.00	75.55	86.00	-10.45	peak	
9		5.0800	57.18	0.00	57.18	79.82	-22.64	AVG	
10		5.1200	68.13	0.00	68.13	89.74	-21.61	peak	
11		8.3200	68.07	0.00	68.07	84.32	-16.25	peak	
12		8.5200	55.05	0.00	55.05	74.05	-19.00	AVG	

*:Maximum data x:Over limit !:over margin Comment: Factor build in receiver. Operator: HJ

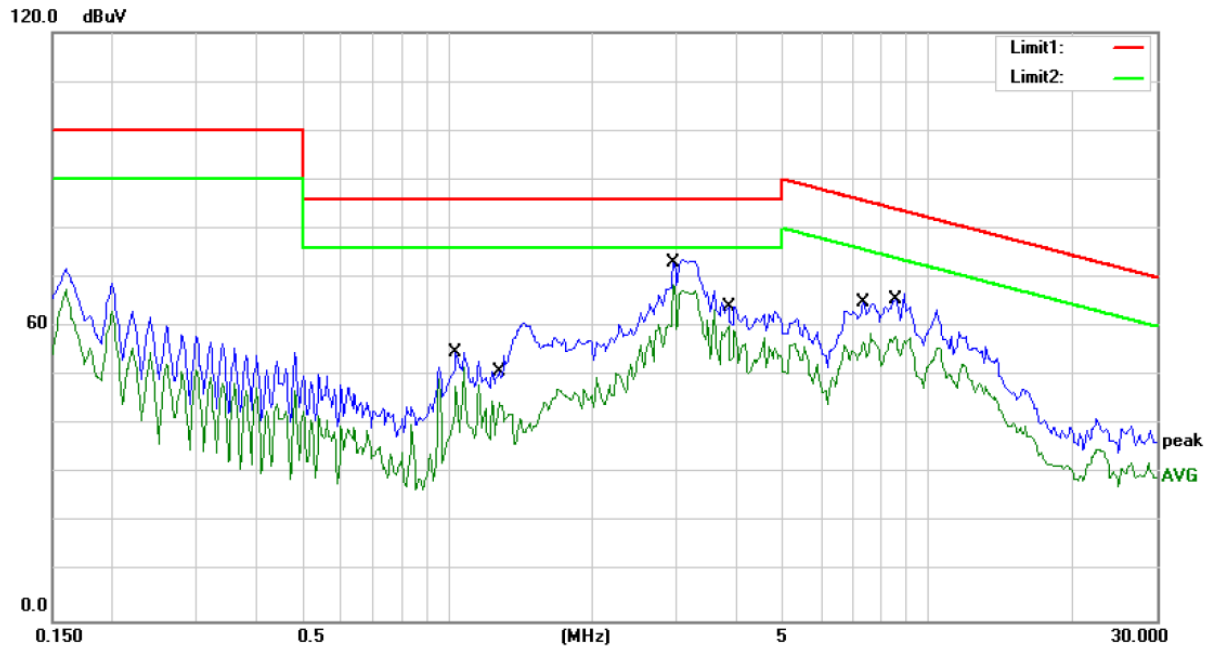

Site Conduction #2

Phase: **N**

Temperature: 26

Limit: (CE)EN62040-2 C3_QP

Power: AC 380V

Humidity: 55 %

Mode: BAT MODE

Note:

No.	Mk.	Freq.	Reading Level	Correct Factor	Measurement	Limit	Over	Detector	Comment
		MHz	dBuV	dB	dBuV	dBuV	dB		
1		1.0400	54.70	0.00	54.70	86.00	-31.30	QP	
2		1.0400	51.66	0.00	51.66	76.00	-24.34	AVG	
3		1.2800	60.68	0.00	60.68	86.00	-25.32	QP	
4		1.2800	44.40	0.00	44.40	76.00	-31.60	AVG	
5		2.9600	73.55	0.00	73.55	86.00	-12.45	QP	
6	*	2.9600	68.56	0.00	68.56	76.00	-7.44	AVG	
7		3.8400	64.06	0.00	64.06	86.00	-21.94	QP	
8		3.8400	60.03	0.00	60.03	76.00	-15.97	AVG	
9		7.3600	64.84	0.00	64.84	85.68	-20.84	QP	
10		7.3600	58.51	0.00	58.51	75.68	-17.17	AVG	
11		8.5600	64.18	0.00	64.18	84.00	-19.82	QP	
12		8.5600	58.14	0.00	58.14	74.00	-15.86	AVG	

*:Maximum data x:Over limit !:over margin Comment: Factor build in receiver. Operator: HJ

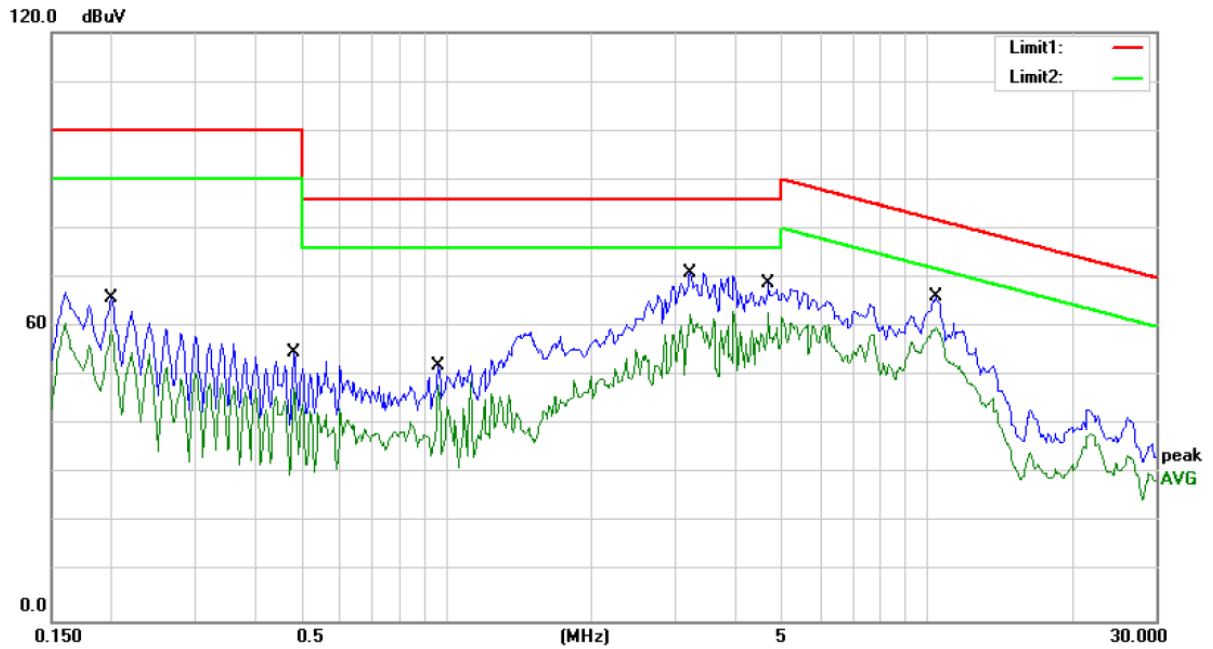

Site Conduction #2

Phase: **L1**

Temperature: 26

Limit: (CE)EN62040-2 C3_QP

Power: AC 380V

Humidity: 55 %

Mode: BAT MODE

Note:

No.	Mk.	Freq. MHz	Reading Level dBuV	Correct Factor dB	Measure- ment dBuV	Limit dBuV	Over dB	Detector	Comment
1		0.2000	65.98	0.00	65.98	100.00	-34.02	QP	
2		0.2000	59.15	0.00	59.15	90.00	-30.85	AVG	
3		0.4800	54.73	0.00	54.73	100.00	-45.27	QP	
4		0.4800	47.45	0.00	47.45	90.00	-42.55	AVG	
5		0.9600	52.01	0.00	52.01	86.00	-33.99	QP	
6		0.9600	48.76	0.00	48.76	76.00	-27.24	AVG	
7		3.2070	70.87	0.00	70.87	86.00	-15.13	QP	
8		3.2070	62.42	0.00	62.42	76.00	-13.58	AVG	
9		4.6800	68.92	0.00	68.92	86.00	-17.08	QP	
10		4.6800	62.98	0.00	62.98	76.00	-13.02	AVG	
11		10.4000	66.10	0.00	66.10	81.83	-15.73	QP	
12	*	10.4000	59.89	0.00	59.89	71.83	-11.94	AVG	

*:Maximum data x:Over limit !:over margin Comment: Factor build in receiver. Operator: HJ

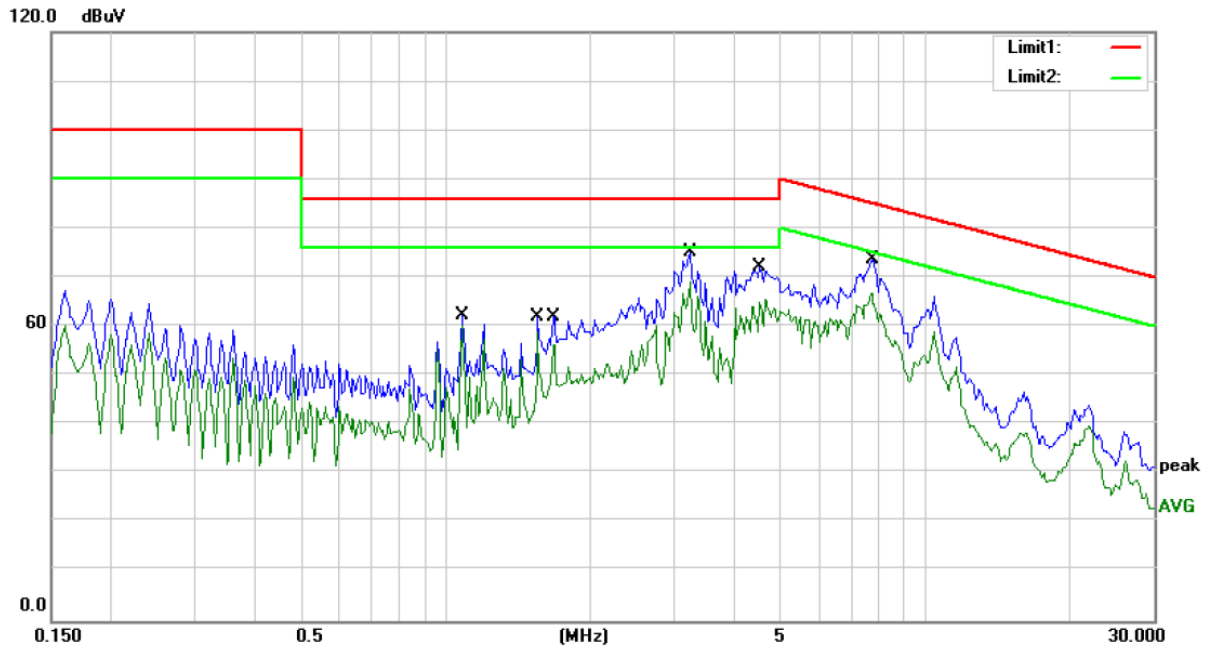

Site Conduction #2

Phase: **L2**

Temperature: 26

Limit: (CE)EN62040-2 C3_QP

Power: AC 380V

Humidity: 55 %

Mode: BAT MODE

Note:

No.	Mk.	Freq.	Reading Level	Correct Factor	Measurement	Limit	Over	Detector	Comment
		MHz	dBuV	dB	dBuV	dBuV	dB		
1		1.0800	62.39	0.00	62.39	86.00	-23.61	QP	
2		1.0800	60.30	0.00	60.30	76.00	-15.70	AVG	
3		1.5600	61.86	0.00	61.86	86.00	-24.14	QP	
4		1.5600	58.89	0.00	58.89	76.00	-17.11	AVG	
5		1.6800	62.05	0.00	62.05	86.00	-23.95	QP	
6		1.6800	56.22	0.00	56.22	76.00	-19.78	AVG	
7		3.2400	75.24	0.00	75.24	86.00	-10.76	QP	
8	*	3.2400	69.06	0.00	69.06	76.00	-6.94	AVG	
9		4.5150	72.03	0.00	72.03	86.00	-13.97	QP	
10		4.5150	65.63	0.00	65.63	76.00	-10.37	AVG	
11		7.7200	73.55	0.00	73.55	85.15	-11.60	QP	
12		7.7200	66.85	0.00	66.85	75.15	-8.30	AVG	

*:Maximum data x:Over limit !:over margin Comment: Factor build in receiver. Operator: HJ

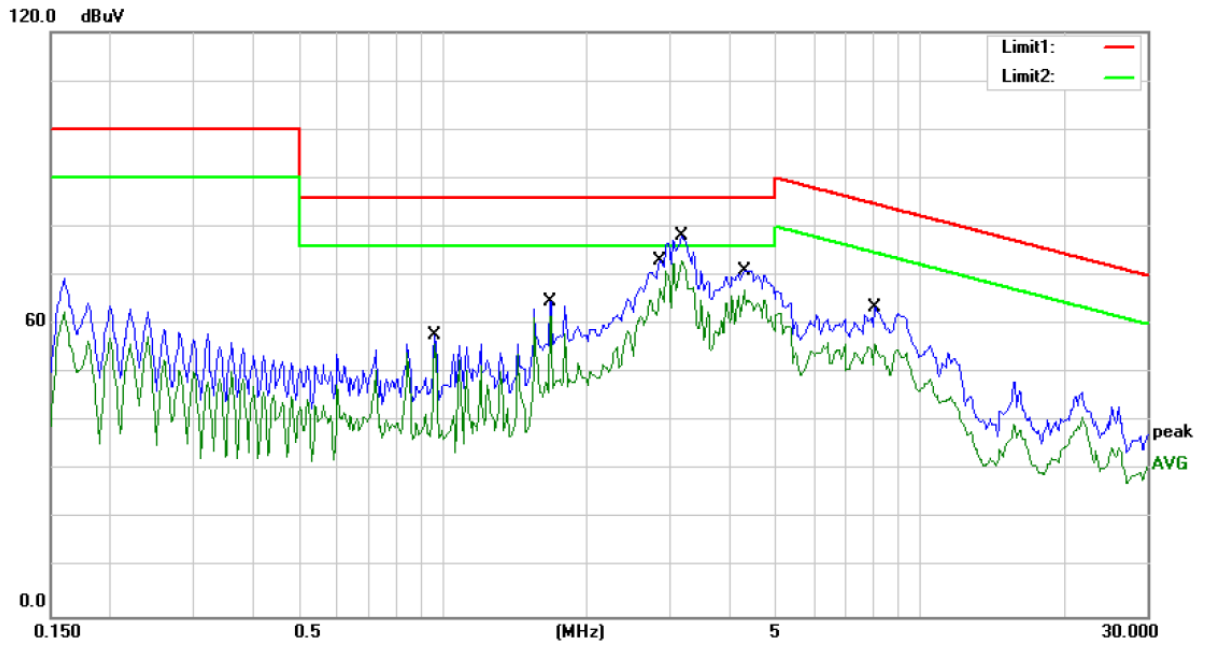

Site Conduction #2

Phase: **L3**

Temperature: 26

Limit: (CE)EN62040-2 C3_QP

Power: AC 380V

Humidity: 55 %

Mode: BAT MODE

Note:

No.	Mk.	Freq. MHz	Reading Level dBuV	Correct Factor dB	Measure- ment dBuV	Limit dBuV	Over dB	Detector	Comment
1		0.9600	57.83	0.00	57.83	86.00	-28.17	QP	
2		0.9600	55.84	0.00	55.84	76.00	-20.16	AVG	
3		1.6800	64.59	0.00	64.59	86.00	-21.41	QP	
4		1.6800	61.71	0.00	61.71	76.00	-14.29	AVG	
5		2.8400	73.18	0.00	73.18	86.00	-12.82	QP	
6		2.8400	70.86	0.00	70.86	76.00	-5.14	AVG	
7		3.1600	78.07	0.00	78.07	86.00	-7.93	QP	
8	*	3.1600	72.94	0.00	72.94	76.00	-3.06	AVG	
9		4.2800	71.08	0.00	71.08	86.00	-14.92	QP	
10		4.2800	67.18	0.00	67.18	76.00	-8.82	AVG	
11		8.0400	63.54	0.00	63.54	84.70	-21.16	QP	
12		8.0400	54.65	0.00	54.65	74.70	-20.05	AVG	

*:Maximum data x:Over limit !:over margin Comment: Factor build in receiver. Operator: HJ

RM020/10X

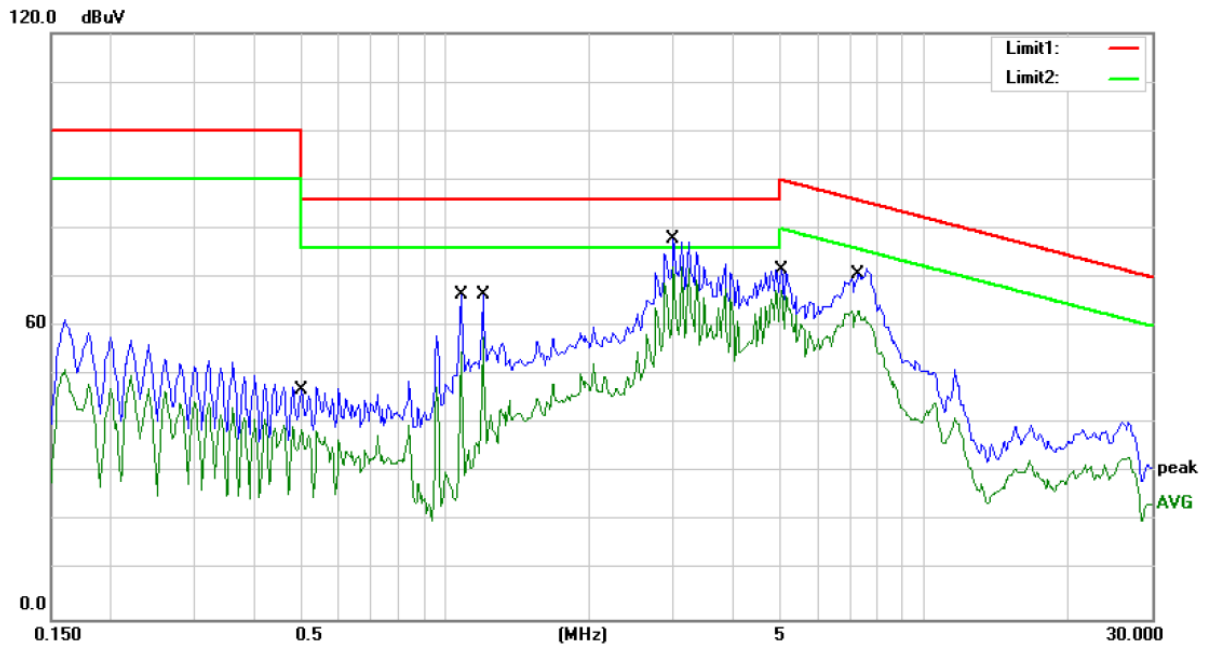

Site Conduction #2

Phase: **N**

Temperature: 26

Limit: (CE)EN62040-2 C3_QP

Power: AC 380V

Humidity: 55 %

Mode: LINE MODE

Note:

No.	Mk.	Freq.	Reading Level	Correct Factor	Measurement	Limit	Over	Detector	Comment
		MHz	dBuV	dB	dBuV	dBuV	dB		
1		0.5000	47.68	0.00	47.68	86.00	-38.32	QP	
2		0.5000	38.96	0.00	38.96	76.00	-37.04	AVG	
3		1.0800	66.37	0.00	66.37	86.00	-19.63	QP	
4		1.0800	54.66	0.00	54.66	76.00	-21.34	AVG	
5		1.2000	66.55	0.00	66.55	86.00	-19.45	QP	
6		1.2000	57.60	0.00	57.60	76.00	-18.40	AVG	
7		3.0000	77.95	0.00	77.95	86.00	-8.05	QP	
8	*	3.0000	72.02	0.00	72.02	76.00	-3.98	AVG	
9		5.0400	71.52	0.00	71.52	89.91	-18.39	QP	
10		5.0400	67.41	0.00	67.41	79.91	-12.50	AVG	
11		7.3200	71.72	0.00	71.72	85.75	-14.03	QP	
12		7.3200	63.22	0.00	63.22	75.75	-12.53	AVG	

*:Maximum data x:Over limit !:over margin Comment: Factor build in receiver. Operator: HJ



Site Conduction #2

Phase: **L1**

Temperature: 26

Limit: (CE)EN62040-2 C3_QP

Power: AC 380V

Humidity: 55 %

Mode: LINE MODE

Note:

No.	Mk.	Freq.	Reading Level	Correct Factor	Measurement	Limit	Over	Detector	Comment
		MHz	dBuV	dB	dBuV	dBuV	dB		
1		1.2000	54.84	0.00	54.84	86.00	-31.16	QP	
2		1.2000	48.71	0.00	48.71	76.00	-27.29	AVG	
3		2.9600	72.21	0.00	72.21	86.00	-13.79	QP	
4	*	2.9600	64.10	0.00	64.10	76.00	-11.90	AVG	
5		4.7200	64.85	0.00	64.85	86.00	-21.15	QP	
6		4.7200	57.96	0.00	57.96	76.00	-18.04	AVG	
7		7.6000	69.15	0.00	69.15	85.33	-16.18	QP	
8		7.6000	61.95	0.00	61.95	75.33	-13.38	AVG	
9		10.6000	55.98	0.00	55.98	81.61	-25.63	QP	
10		10.6000	46.57	0.00	46.57	71.61	-25.04	AVG	
11		15.6750	48.75	0.00	48.75	77.25	-28.50	QP	
12		15.6750	40.89	0.00	40.89	67.25	-26.36	AVG	

*:Maximum data x:Over limit !:over margin Comment: Factor build in receiver. Operator: HJ



Site Conduction #2

Phase: **L2**

Temperature: 26

Limit: (CE)EN62040-2 C3_QP

Power: AC 380V

Humidity: 55 %

Mode: LINE MODE

Note:

No.	Mk.	Freq.	Reading Level	Correct Factor	Measurement	Limit	Over	Detector	Comment
		MHz	dBuV	dB	dBuV	dBuV	dB		
1		1.2000	65.98	0.00	65.98	86.00	-20.02	QP	
2		1.2000	63.14	0.00	63.14	76.00	-12.86	AVG	
3		1.8000	62.84	0.00	62.84	86.00	-23.16	QP	
4		1.8000	58.77	0.00	58.77	76.00	-17.23	AVG	
5		2.8800	74.32	0.00	74.32	86.00	-11.68	QP	
6		2.8800	60.45	0.00	60.45	76.00	-15.55	AVG	
7		3.9600	77.00	0.00	77.00	86.00	-9.00	QP	
8	*	3.9600	70.01	0.00	70.01	76.00	-5.99	AVG	
9		6.2400	70.10	0.00	70.10	87.53	-17.43	QP	
10		6.2400	66.32	0.00	66.32	77.53	-11.21	AVG	
11		7.6000	73.52	0.00	73.52	85.33	-11.81	QP	
12		7.6000	64.90	0.00	64.90	75.33	-10.43	AVG	

*:Maximum data x:Over limit !:over margin Comment: Factor build in receiver. Operator: HJ

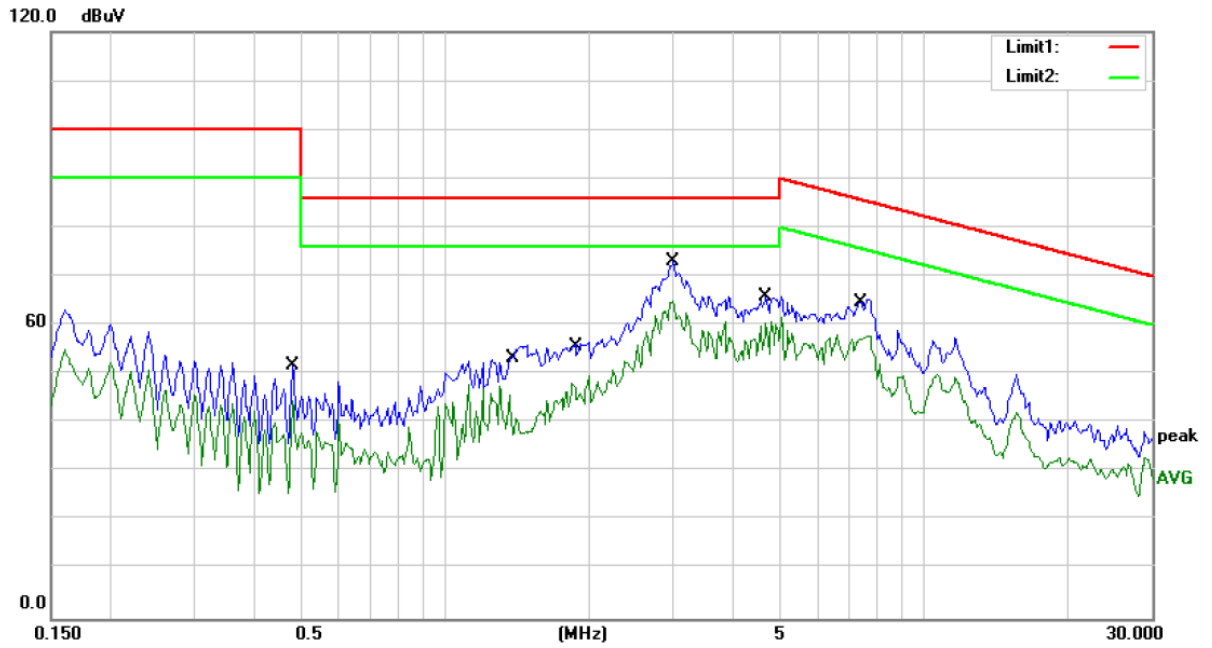

Site Conduction #2

Phase: **L3**

Temperature: 26

Limit: (CE)EN62040-2 C3_QP

Power: AC 380V

Humidity: 55 %

Mode: LINE MODE

Note:

No.	Mk.	Freq.	Reading Level	Correct Factor	Measurement	Limit	Over	Detector	Comment
		MHz	dBuV	dB	dBuV	dBuV	dB		
1		0.4800	51.74	0.00	51.74	100.00	-48.26	QP	
2		0.4800	44.52	0.00	44.52	90.00	-45.48	AVG	
3		1.3600	55.18	0.00	55.18	86.00	-30.82	QP	
4		1.3600	45.60	0.00	45.60	76.00	-30.40	AVG	
5		1.8400	56.61	0.00	56.61	86.00	-29.39	QP	
6		1.8400	48.25	0.00	48.25	76.00	-27.75	AVG	
7		3.0000	73.06	0.00	73.06	86.00	-12.94	QP	
8	*	3.0000	65.00	0.00	65.00	76.00	-11.00	AVG	
9		4.6800	65.76	0.00	65.76	86.00	-20.24	QP	
10		4.6800	60.70	0.00	60.70	76.00	-15.30	AVG	
11		7.2903	63.98	0.00	63.98	85.79	-21.81	QP	
12		7.2903	57.22	0.00	57.22	75.79	-18.57	AVG	

*:Maximum data x:Over limit !:over margin Comment: Factor build in receiver. Operator: HJ

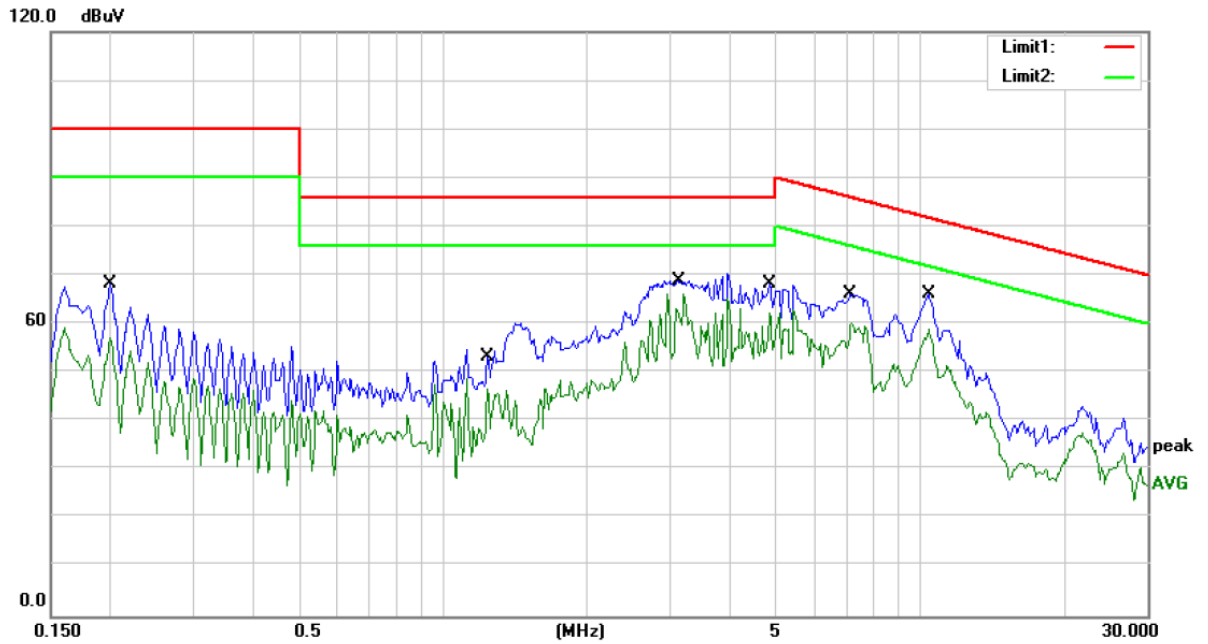

Site Conduction #2

Phase: **N**

Temperature: 26

Limit: (CE)EN62040-2 C3_QP

Power: AC 380V

Humidity: 55 %

Mode: BAT MODE

Note:

No.	Mk.	Freq.	Reading Level	Correct Factor	Measurement	Limit	Over	Detector	Comment
		MHz	dBuV	dB	dBuV	dBuV	dB		
1		0.2000	68.16	0.00	68.16	100.00	-31.84	QP	
2		0.2000	57.27	0.00	57.27	90.00	-32.73	AVG	
3		1.2400	60.23	0.00	60.23	86.00	-25.77	QP	
4		1.2400	46.50	0.00	46.50	76.00	-29.50	AVG	
5		3.1200	68.86	0.00	68.86	86.00	-17.14	QP	
6	*	3.1200	66.22	0.00	66.22	76.00	-9.78	AVG	
7		4.8400	68.21	0.00	68.21	86.00	-17.79	QP	
8		4.8400	62.26	0.00	62.26	76.00	-13.74	AVG	
9		7.1600	66.24	0.00	66.24	85.99	-19.75	QP	
10		7.1600	60.08	0.00	60.08	75.99	-15.91	AVG	
11		10.4000	64.05	0.00	64.05	81.83	-17.78	QP	
12		10.4000	59.08	0.00	59.08	71.83	-12.75	AVG	

*:Maximum data x:Over limit !:over margin Comment: Factor build in receiver. Operator: HJ

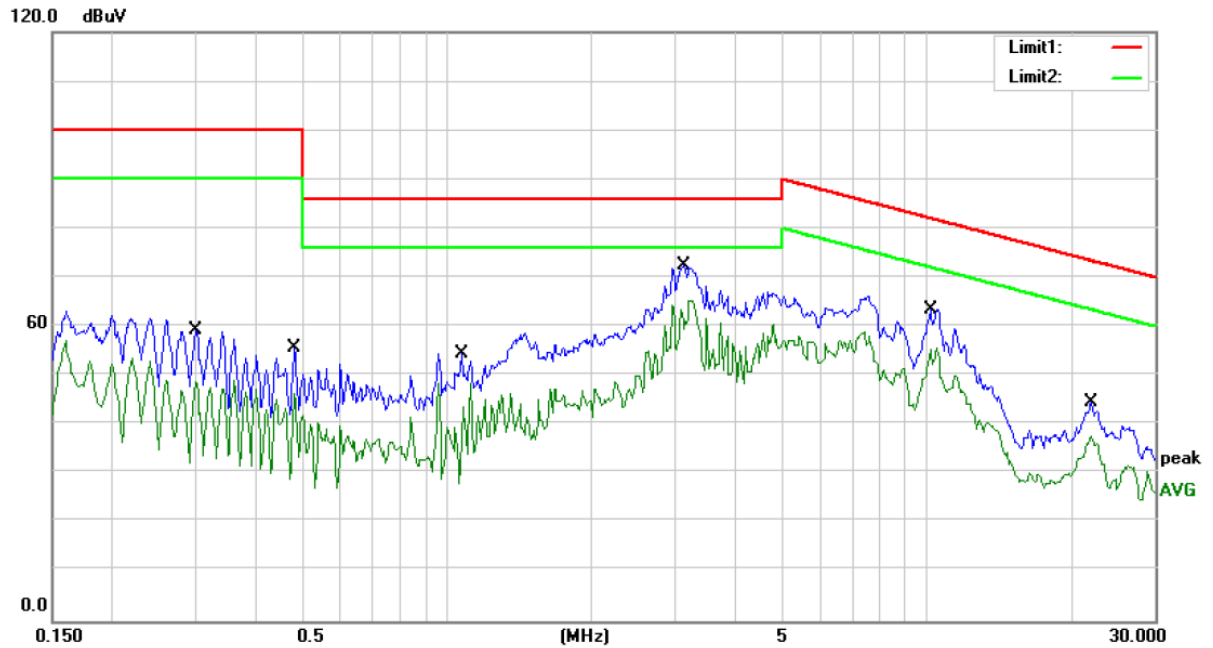

Site Conduction #2

Phase: **L1**

Temperature: 26

Limit: (CE)EN62040-2 C3_QP

Power: AC 380V

Humidity: 55 %

Mode: BAT MODE

Note:

No.	Mk.	Freq.	Reading Level	Correct Factor	Measurement	Limit	Over	Detector	Comment
		MHz	dBuV	dB	dBuV	dBuV	dB		
1		0.3000	59.35	0.00	59.35	100.00	-40.65	QP	
2		0.3000	48.65	0.00	48.65	90.00	-41.35	AVG	
3		0.4800	55.74	0.00	55.74	100.00	-44.26	QP	
4		0.4800	46.40	0.00	46.40	90.00	-43.60	AVG	
5		1.0750	54.34	0.00	54.34	86.00	-31.66	QP	
6		1.0750	48.34	0.00	48.34	76.00	-27.66	AVG	
7		3.1065	72.47	0.00	72.47	86.00	-13.53	QP	
8	*	3.1065	65.26	0.00	65.26	76.00	-10.74	AVG	
9		10.2000	63.59	0.00	63.59	82.04	-18.45	QP	
10		10.2000	55.24	0.00	55.24	72.04	-16.80	AVG	
11		22.0750	44.55	0.00	44.55	73.42	-28.87	QP	
12		22.0750	37.74	0.00	37.74	63.42	-25.68	AVG	

*:Maximum data x:Over limit !:over margin Comment: Factor build in receiver. Operator: HJ

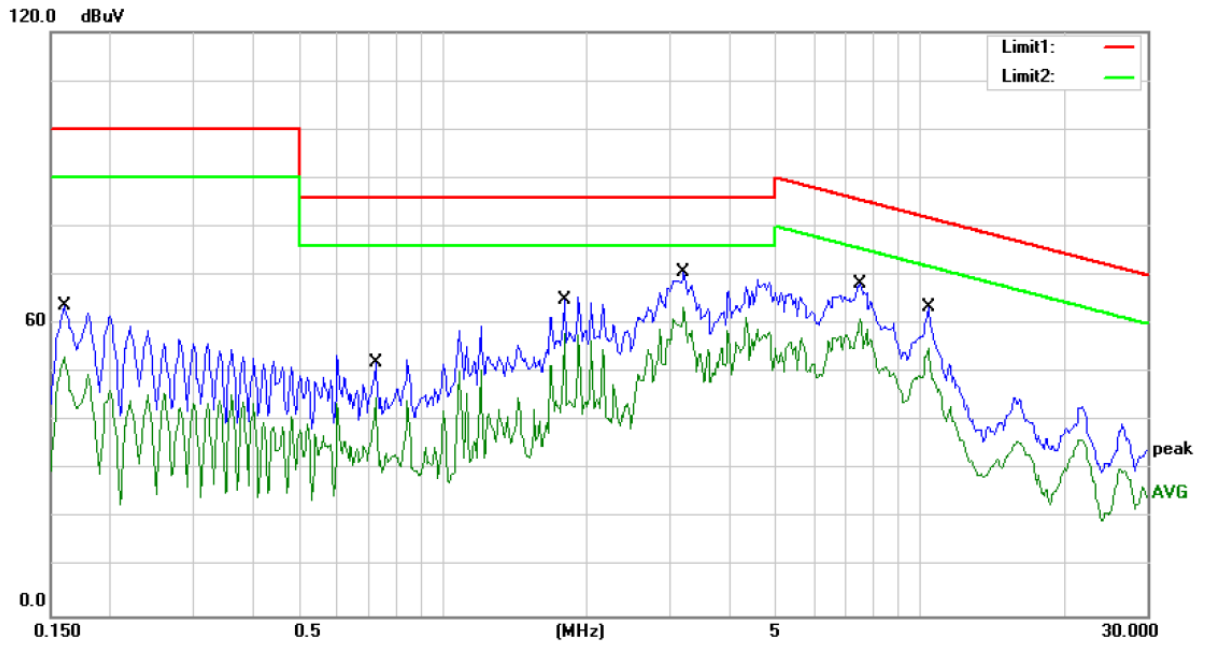

Site Conduction #2

Phase: **L2**

Temperature: 26

Limit: (CE)EN62040-2 C3_QP

Power: AC 380V

Humidity: 55 %

Mode: BAT MODE

Note:

No.	Mk.	Freq.	Reading Level	Correct Factor	Measurement	Limit	Over	Detector	Comment
		MHz	dBuV	dB	dBuV	dBuV	dB		
1		0.1600	63.68	0.00	63.68	100.00	-36.32	QP	
2		0.1600	53.38	0.00	53.38	90.00	-36.62	AVG	
3		0.7200	51.99	0.00	51.99	86.00	-34.01	QP	
4		0.7200	44.89	0.00	44.89	76.00	-31.11	AVG	
5		1.8000	65.49	0.00	65.49	86.00	-20.51	QP	
6		1.8000	58.13	0.00	58.13	76.00	-17.87	AVG	
7		3.2000	70.71	0.00	70.71	86.00	-15.29	QP	
8	*	3.2000	63.46	0.00	63.46	76.00	-12.54	AVG	
9		7.5200	68.13	0.00	68.13	85.44	-17.31	QP	
10		7.5200	60.97	0.00	60.97	75.44	-14.47	AVG	
11		10.4000	63.47	0.00	63.47	81.83	-18.36	QP	
12		10.4000	55.00	0.00	55.00	71.83	-16.83	AVG	

*:Maximum data x:Over limit !:over margin Comment: Factor build in receiver. Operator: HJ



Site Conduction #2

Phase: **L3**

Temperature: 26

Limit: (CE)EN62040-2 C3_QP

Power: AC 380V

Humidity: 55 %

Mode: BAT MODE

Note:

No.	Mk.	Freq.	Reading Level	Correct Factor	Measurement	Limit	Over	Detector	Comment
		MHz	dBuV	dB	dBuV	dBuV	dB		
1		1.8000	62.52	0.00	62.52	86.00	-23.48	QP	
2		1.8000	56.40	0.00	56.40	76.00	-19.60	AVG	
3		2.0400	66.96	0.00	66.96	86.00	-19.04	QP	
4		2.0400	59.04	0.00	59.04	76.00	-16.96	AVG	
5		2.7600	74.03	0.00	74.03	86.00	-11.97	QP	
6		2.7600	65.81	0.00	65.81	76.00	-10.19	AVG	
7		3.9600	75.67	0.00	75.67	86.00	-10.33	QP	
8		3.9600	67.01	0.00	67.01	76.00	-8.99	AVG	
9		4.4400	76.21	0.00	76.21	86.00	-9.79	QP	
10	*	4.4400	69.23	0.00	69.23	76.00	-6.77	AVG	
11		6.7200	69.15	0.00	69.15	86.70	-17.55	QP	
12		6.7200	64.41	0.00	64.41	76.70	-12.29	AVG	

*:Maximum data x:Over limit !:over margin Comment: Factor build in receiver. Operator: HJ

5. RADIATED EMISSION MEASUREMENT

5.1. Block Diagram of Test

5.1.1. Block diagram of connection between the EUT and simulators.



(EUT: Uninterruptible Power Systems)

5.1.2. Block diagram of test setup (In chamber)

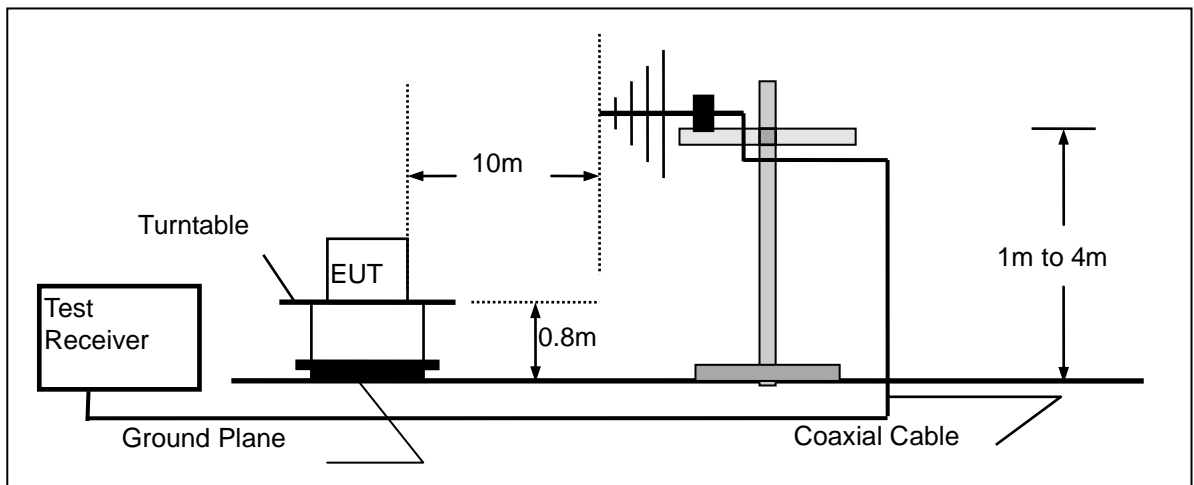

(EUT: Uninterruptible Power Systems)

5.2. Measuring Standard

EN62040-2: 2006 Category C3

5.3. Radiated Emission Limits

EN62040-2: 2006 Category C3 Limits:

All emanations from a C3 device or system, including any network of conductors and apparatus connected thereto, shall not exceed the level of field strengths specified below:

FREQUENCY (MHz)	DISTANCE (Meters)	FIELD STRENGTHS LIMIT (dB μ V/m)
30 ~ 230	10	50
230 ~ 1000	10	60

- Note:
- (1) The smaller limit shall apply at the combination point between two frequency bands.
 - (2) Distance refers to the distance in meters between the measuring instrument antenna and the closed point of any part of the EUT.

5.4. EUT Configuration on Test

The EN62040-2 regulations test method must be used to find the maximum emission during radiated emission measurement.

5.5. Operating Condition of EUT

5.5.1. Turn on the power.

5.5.2. After that, let the EUT work in test mode (Line mode/Battery mode) and measure it.

5.6. Test Procedure

The EUT is placed on a turn table which is 0.8 meter high above the ground. The turn table can rotate 360 degrees to determine the position of the maximum emission level. The EUT is set 10 meters away from the receiving antenna which is mounted on a antenna tower. The antenna can be moved up and down from 1 to 4 meters to find out the maximum emission level. Bilog antenna (calibrated by Dipole Antenna) is used as a receiving antenna. Both horizontal and vertical polarization of the antenna are set on test.

The bandwidth of the Receiver is set at 120kHz.
All the scanning curves are attached in Appendix II.

5.7. Measuring Results

PASS.

The frequency range from 30MHz to 1000MHz is investigated.

Please reference to Appendix II.

RM040/10X

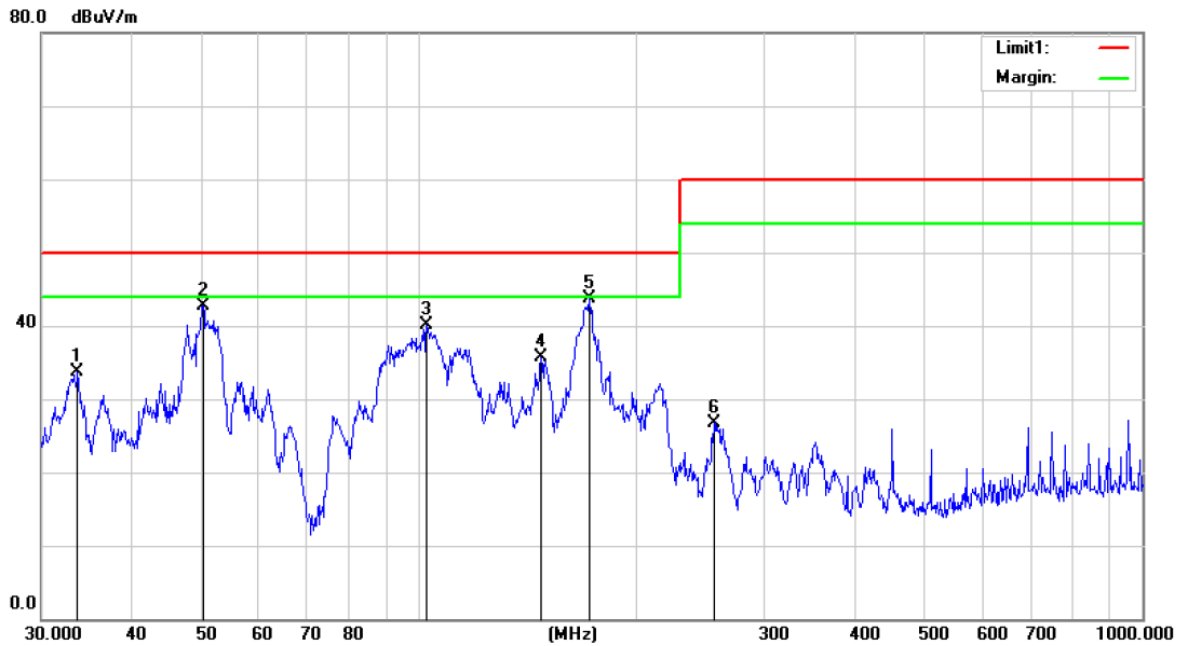

Site :10m Chamber #1 Polarization: **Horizontal** Temperature: 26
 Limit: (RE 10M)EN62040-2 C3 Power: AC 380V/50Hz Humidity: 60 %
 Mode:FULL LOAD
 Note: LINE MODE

No.	Mk.	Freq.	Reading Level	Correct Factor	Measurement	Limit	Over	Antenna Height	Table Degree	
		MHz	dBuV	dB	dBuV/m	dBuV/m	dB	cm	degree	Comment
1		33.6802	66.80	-33.11	33.69	50.00	-16.31			QP
2		50.2324	73.15	-30.43	42.72	50.00	-7.28			QP
3		102.3597	72.51	-32.34	40.17	50.00	-9.83			QP
4		147.4036	71.37	-35.68	35.69	50.00	-14.31			QP
5	*	171.9945	78.16	-34.50	43.66	50.00	-6.34			QP
6		255.6230	57.31	-30.53	26.78	60.00	-33.22			QP

*:Maximum data x:Over limit !:over margin

Operator: CSL

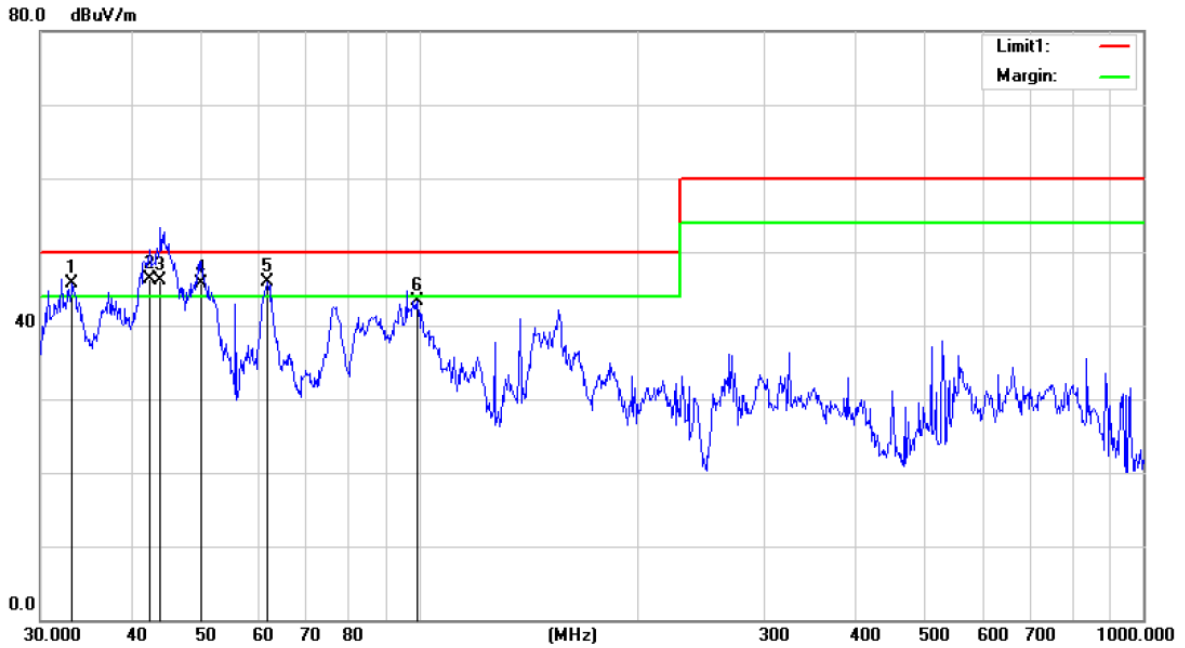

Site :10m Chamber #1 Polarization: **Vertical** Temperature: 26
 Limit: (RE 10M)EN62040-2 C3 Power: AC 380V/50Hz Humidity: 60 %
 Mode:FULL LOAD
 Note: LINE MODE

No.	Mk.	Freq.	Reading Level	Correct Factor	Measurement	Limit	Over	Antenna Height	Table Degree	
		MHz	dBuV	dB	dBuV/m	dBuV/m	dB	cm	degree	Comment
1	!	33.2111	78.44	-32.73	45.71	50.00	-4.29	QP		
2	*	42.4508	76.78	-30.48	46.30	50.00	-3.70	QP		
3	!	43.9658	76.39	-30.19	46.20	50.00	-3.80	QP		
4	!	50.0566	75.70	-29.90	45.80	50.00	-4.20	QP		
5	!	61.7781	76.13	-30.20	45.93	50.00	-4.07	QP		
6		99.5280	75.05	-31.71	43.34	50.00	-6.66	QP		

*:Maximum data x:Over limit !:over margin

Operator: CSL

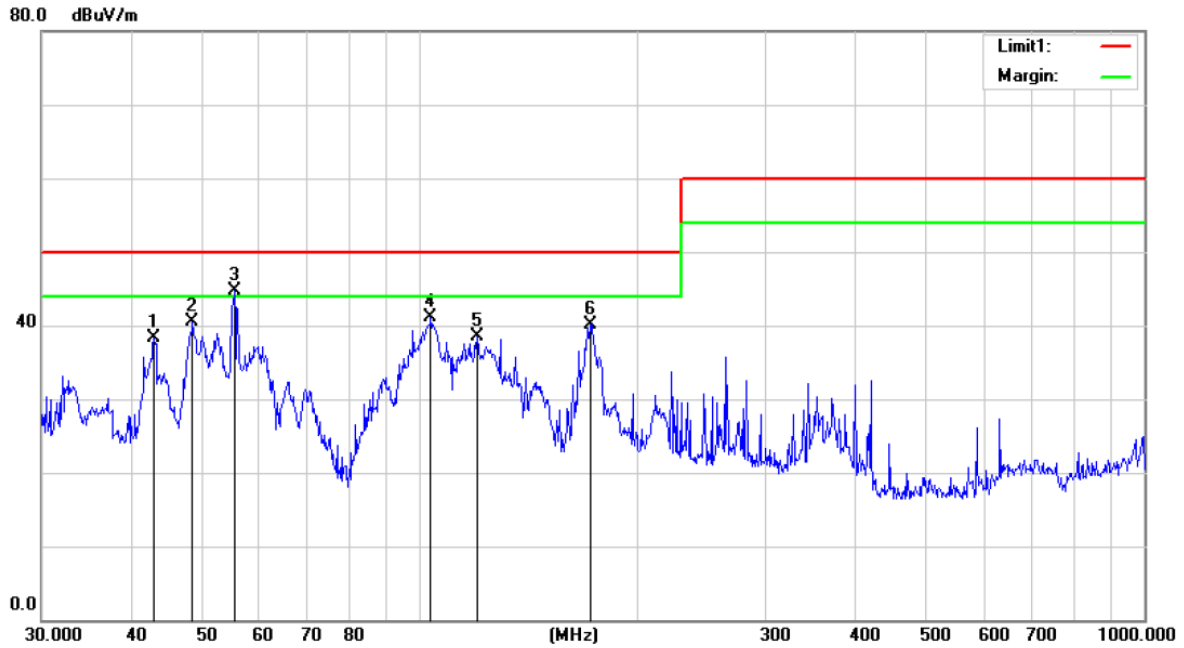

Site :10m Chamber #1 Polarization: **Horizontal** Temperature: 26
 Limit: (RE 10M)EN62040-2 C3 Power: AC 380V/50Hz Humidity: 60 %
 Mode:FULL LOAD
 Note: BAT MODE

No.	Mk.	Freq. MHz	Reading Level dBuV	Correct Factor dB	Measure- ment dBuV/m	Limit dBuV/m	Over dB	Detector	Antenna Height cm	Table Degree	Comment
1		42.8997	69.11	-30.84	38.27	50.00	-11.73	QP			
2		48.5016	70.88	-30.40	40.48	50.00	-9.52	QP			
3	*	55.4147	75.97	-31.23	44.74	50.00	-5.26	QP			
4		103.4420	73.41	-32.34	41.07	50.00	-8.93	QP			
5		119.8555	72.61	-34.04	38.57	50.00	-11.43	QP			
6		171.9945	74.56	-34.50	40.06	50.00	-9.94	QP			

*:Maximum data x:Over limit !:over margin

Operator: CSL

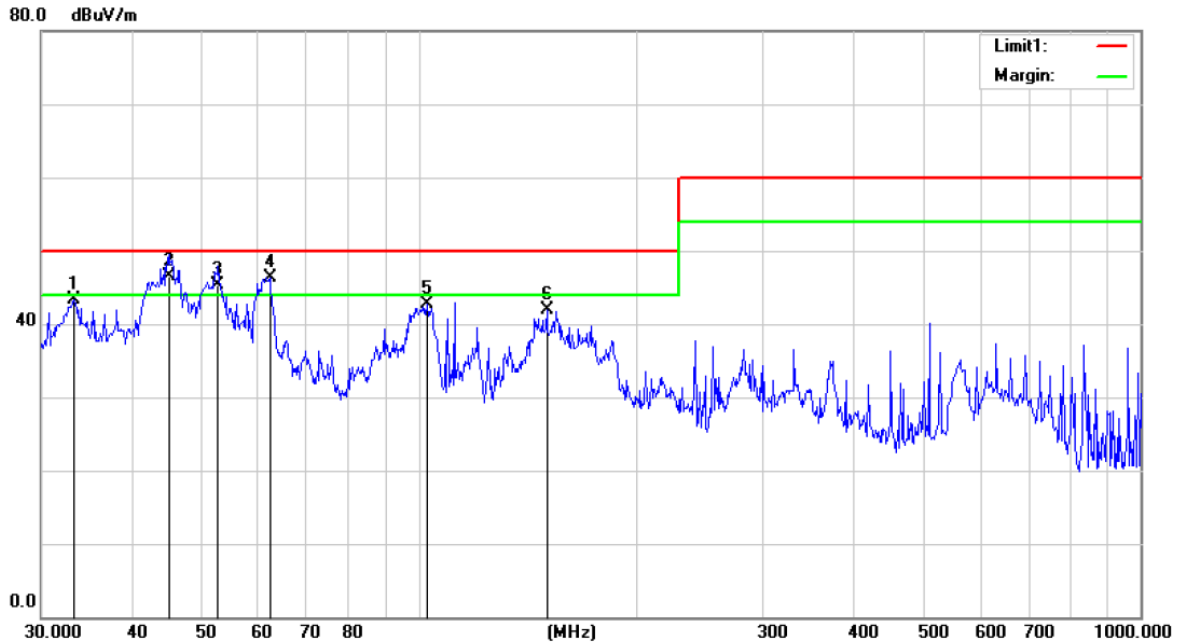

Site :10m Chamber #1 Polarization: **Vertical** Temperature: 26
 Limit: (RE 10M)EN62040-2 C3 Power: AC 380V/50Hz Humidity: 60 %
 Mode:FULL LOAD
 Note: BAT MODE

No.	Mk.	Freq.	Reading Level	Correct Factor	Measurement	Limit	Over	Antenna Height	Table Degree	
		MHz	dBuV	dB	dBuV/m	dBuV/m	dB	cm	degree	Comment
1		33.3278	76.00	-32.73	43.27	50.00	-6.73			QP
2	*	45.0583	76.48	-29.98	46.50	50.00	-3.50			QP
3	!	52.7600	75.07	-29.77	45.30	50.00	-4.70			QP
4	!	62.2128	76.79	-30.40	46.39	50.00	-3.61			QP
5		102.7192	74.42	-31.64	42.78	50.00	-7.22			QP
6		150.5378	76.51	-34.69	41.82	50.00	-8.18			QP

*:Maximum data x:Over limit !:over margin

Operator: CSL

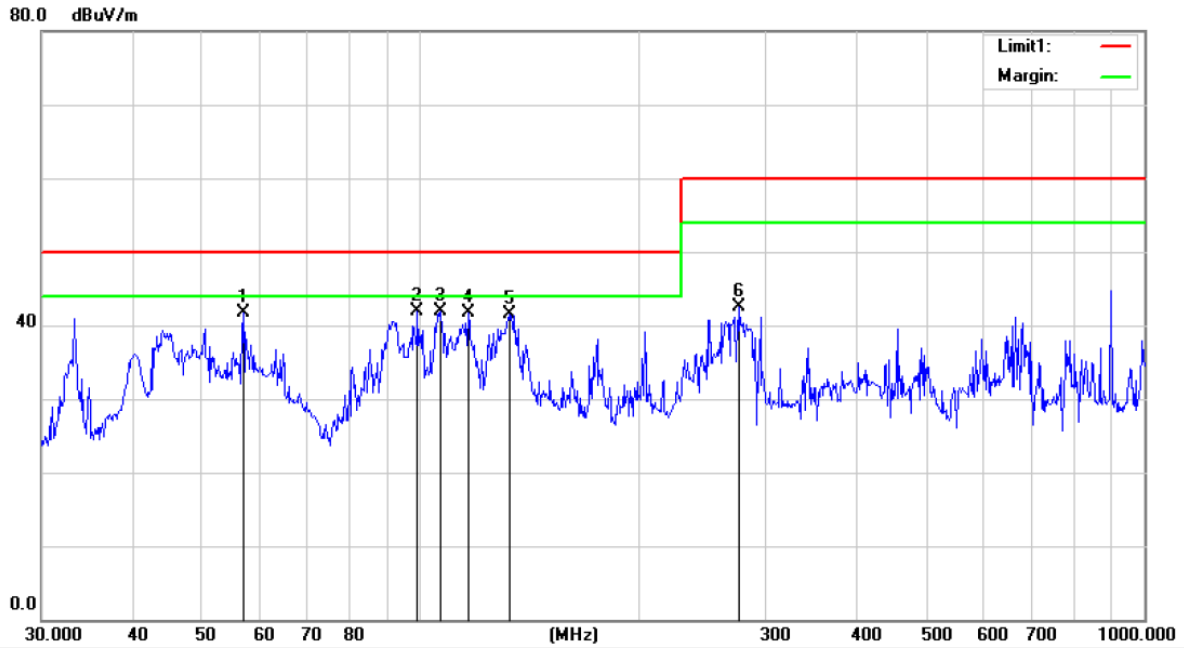

Site :10m Chamber #1 Polarization: **Horizontal** Temperature: 26
 Limit: (RE 10M)EN62040-2 C3 Power: AC 380V/50Hz Humidity: 60 %
 Mode:FULL LOAD
 Note: LINE MODE

No.	Mk.	Freq. MHz	Reading Level dBuV	Correct Factor dB	Measure- ment dBuV/m	Limit dBuV/m	Over dB	Detector	Antenna Height cm	Table Degree	Comment
1		56.9912	73.21	-31.47	41.74	50.00	-8.26	QP			
2	*	99.1796	74.45	-32.47	41.98	50.00	-8.02	QP			
3		106.7587	74.32	-32.38	41.94	50.00	-8.06	QP			
4		116.5400	75.20	-33.48	41.72	50.00	-8.28	QP			
5		133.1511	77.22	-35.64	41.58	50.00	-8.42	QP			
6		276.1235	72.50	-30.06	42.44	60.00	-17.56	QP			

*:Maximum data x:Over limit !:over margin

Operator: CSL

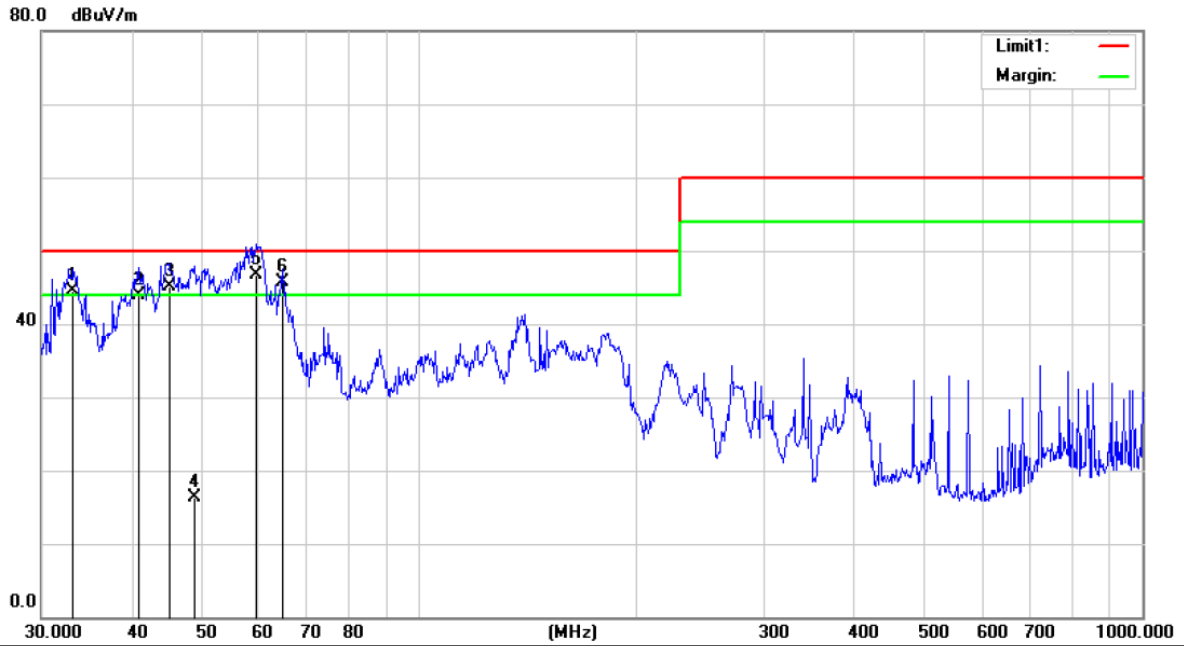

Site :10m Chamber #1

Polarization: **Vertical**

Temperature: 26

Limit: (RE 10M)EN62040-2 C3

Power: AC 380V/50Hz

Humidity: 60 %

Mode:FULL LOAD

Note: LINE MODE

No.	Mk.	Freq. MHz	Reading Level dBuV	Correct Factor dB	Measure- ment dBuV/m	Limit dBuV/m	Over dB	Antenna Height cm	Table Degree	Comment
1	!	33.2111	77.33	-32.73	44.60	50.00	-5.40	QP		
2		40.8445	74.69	-30.79	43.90	50.00	-6.10	QP		
3	!	45.0583	75.18	-29.98	45.20	50.00	-4.80	QP		
4		48.8430	46.32	-29.92	16.40	50.00	-33.60	QP		
5	*	59.4405	76.22	-29.42	46.80	50.00	-3.20	QP		
6	!	64.6594	77.19	-31.49	45.70	50.00	-4.30	QP		

*:Maximum data x:Over limit !:over margin

Operator: CSL

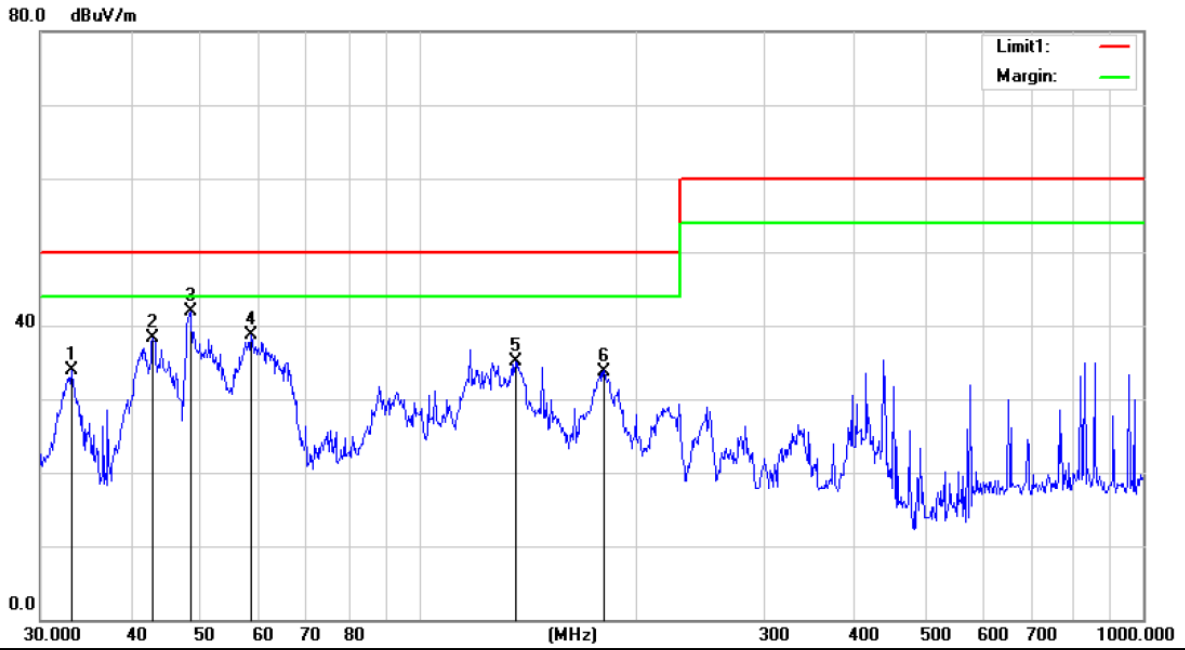

Site :10m Chamber #1

Polarization: *Horizontal*

Temperature: 26

Limit: (RE 10M)EN62040-2 C3

Power: AC 380V/50Hz

Humidity: 60 %

Mode:FULL LOAD

Note: BAT MODE

No.	Mk.	Freq.	Reading Level	Correct Factor	Measurement	Limit	Over	Antenna Height	Table Degree	
		MHz	dBuV	dB	dBuV/m	dBuV/m	dB	cm	degree	Comment
1		33.0950	67.08	-33.15	33.93	50.00	-16.07			QP
2		42.8997	69.05	-30.84	38.21	50.00	-11.79			QP
3	*	48.3318	72.22	-30.41	41.81	50.00	-8.19			QP
4		58.6126	70.33	-31.72	38.61	50.00	-11.39			QP
5		135.9822	70.84	-35.78	35.06	50.00	-14.94			QP
6		180.0165	67.85	-34.05	33.80	50.00	-16.20			QP

*:Maximum data x:Over limit !:over margin

Operator: CSL

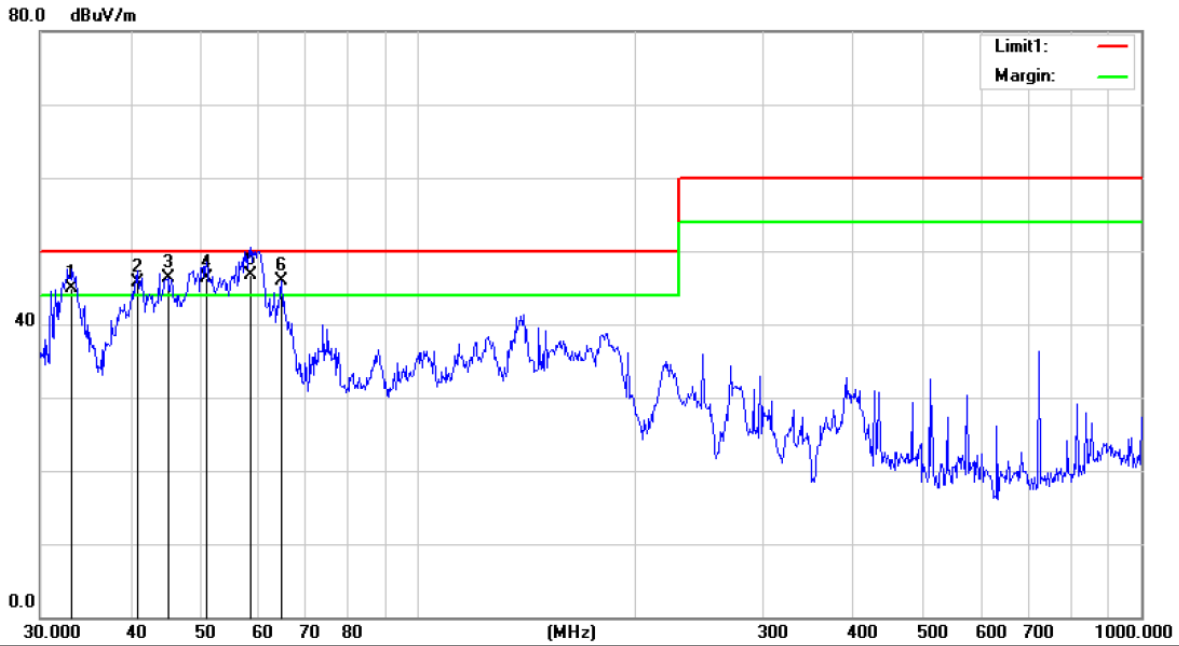

Site :10m Chamber #1 Polarization: **Vertical** Temperature: 26
 Limit: (RE 10M)EN62040-2 C3 Power: AC 380V/50Hz Humidity: 60 %
 Mode:FULL LOAD
 Note: BAT MODE

No.	Mk.	Freq.	Reading Level	Correct Factor	Measurement	Limit	Over	Antenna Height	Table Degree	
		MHz	dBuV	dB	dBuV/m	dBuV/m	dB	cm	degree	Comment
1	!	33.2111	77.63	-32.73	44.90	50.00	-5.10			QP
2	!	40.8444	76.59	-30.79	45.80	50.00	-4.20			QP
3	!	45.0583	76.19	-29.98	46.21	50.00	-3.79			QP
4	!	50.9420	76.16	-29.86	46.30	50.00	-3.70			QP
5	*	58.6126	76.27	-29.47	46.80	50.00	-3.20			QP
6	!	64.6594	77.40	-31.49	45.91	50.00	-4.09			QP

*:Maximum data x:Over limit !:over margin

Operator: CSL

6. HARMONIC CURRENT EMISSION MEASUREMENT

6.1. Block Diagram of Test Setup

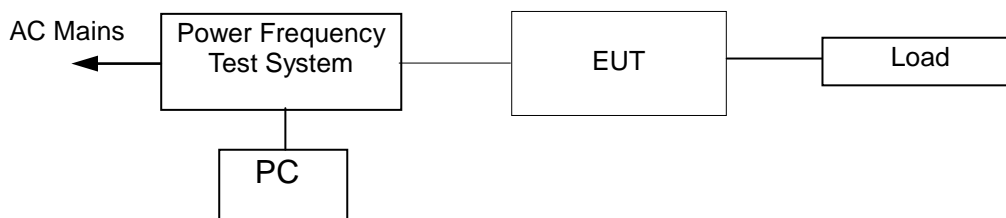

(EUT: Uninterruptible Power Systems)

6.2. Measuring Standard

EN61000-3-12: 2005+A2:2009 CLASS A

6.3. Operation Condition of EUT

Same as Section 4.4, except the test setup replaced as Section 6.1.

6.4. Measuring Results

Not Applicable.

Because power of EUT less than 75W, According standard EN 61000-3-2, Harmonic current unnecessary to test.

7. VOLTAGE FLUCTUATION AND FLICKER MEASUREMENT

7.1. Block Diagram of Test Setup

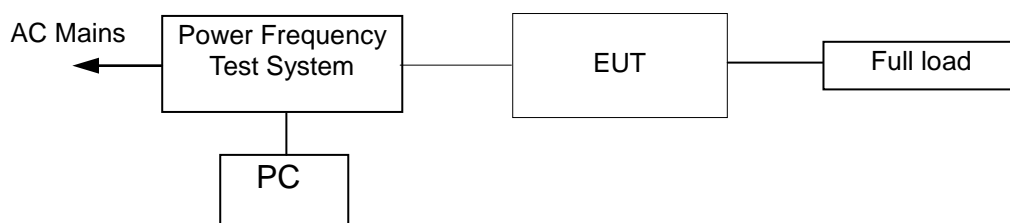

(EUT: Uninterruptible Power Systems)

7.2. Measuring Standard

EN 61000-3-11: 2000

7.3. Operation Condition of EUT

Same as Section 4.4, except the test setup replaced as Section 7.1.

7.4. Measuring Results

Not Applicable.

According to standard EN 61000-3-3 clause 6.1, Voltage fluctuation and flicker isn't required.

8. ELECTROSTATIC DISCHARGE IMMUNITY TEST

8.1. Block Diagram of Test Setup

8.1.1. Block diagram of connection between the EUT and simulators.



(EUT: Uninterruptible Power Systems)

8.1.2. Block diagram of ESD test setup

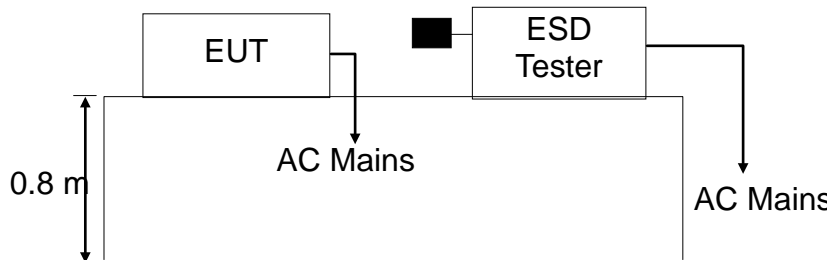

(EUT: Uninterruptible Power Systems)

8.2. Test Standard

EN62040-2:2006

(EN61000-4-2: 2009 Severity Level: 3 / Air Discharge: ± 8 KV
Level: 2/ Contact Discharge: ± 4 KV)

8.3. Severity Levels and Performance Criterion

8.3.1. Severity level

Level	Test Voltage Contact Discharge (KV)	Test Voltage Air Discharge (KV)
1.	± 2	± 2
2.	± 4	± 4
3.	± 6	± 8
4.	± 8	± 15
X	Special	Special

8.3.2. Performance criterion: A

8.4. EUT Configuration

The configuration of EUT is listed in Section 4.3.

8.5. Operating Condition of EUT

Same as conducted emission measurement, which is listed in Section 4.4. Except the test set up replaced by Section 8.1.

8.6. Test Procedure

8.6.1. Air Discharge:

This test is done on a non-conductive surface. The round discharge tip of the discharge electrode shall be approached as fast as possible to touch the EUT. After each discharge, the discharge electrode shall be removed from the EUT. The generator is then re-triggered for a new single discharge and repeated 10 times for each pre-selected test point. This procedure shall be repeated until all the air discharge completed.

8.6.2. Contact Discharge:

All the procedure shall be same as Section 8.6.1. Except that the tip of the discharge electrode shall touch the EUT before the discharge switch is operated.

8.6.3. Indirect discharge for horizontal coupling plane

At least 10 single discharges (in the most sensitive polarity) shall be applied at the front edge of each HCP opposite the center point of each unit (if applicable) of the EUT and 0.1m from the front of the EUT. The long axis of the discharge electrode shall be in the plane of the HCP and perpendicular to its front edge during the discharge.

8.6.4. Indirect discharge for vertical coupling plane

At least 10 singles discharge (in the most sensitive polarity) shall be applied to the center of one vertical edge of the coupling plane. The coupling plane, of dimensions 0.5m X 0.5m, is placed parallel to, and positioned at a distance of 0.1m from the EUT. Discharges shall be applied to the coupling plane, with this plane in sufficient different positions that the four faces of the EUT are completely illuminated.

8.7. Test Results

PASS

Please refer to the following pages

Electrostatic Discharge Test Result

EMTEK (SHENZHEN) CO., LTD

Applicant	: INVT POWER SYSTEM (SHENZHEN) CO., LTD.		
EUT	: Uninterruptible Power Systems	Test Date	: December 28, 2015
M/N	: RM040/10X	Temperature	: 22°C
Power Supply	: AC 380V / 50Hz	Humidity	: 50%
Air discharge	: ± 8.0KV	Test Mode	: Line mode/Battery mode
Contact discharge:	: ± 4.0KV	Criterion	: B
Location	Kind A-Air Discharge C-Contact Discharge	Result	
Slot	A	A	
Metal	C	A	
Screw	C	A	
Screen	C	A	
HCP	C	A	
VCP of front	C	A	
VCP of rear	C	A	
VCP of left	C	A	
VCP of right	C	A	
Test Equipment: ESD Simulator (EMTEST, ESD30C)			

9. RF FIELD STRENGTH SUSCEPTIBILITY TEST

9.1. Block Diagram of Test

9.1.1. Block diagram of connection between the EUT and simulators.



(EUT: Uninterruptible Power Systems)

9.1.2. Block diagram of RS test setup

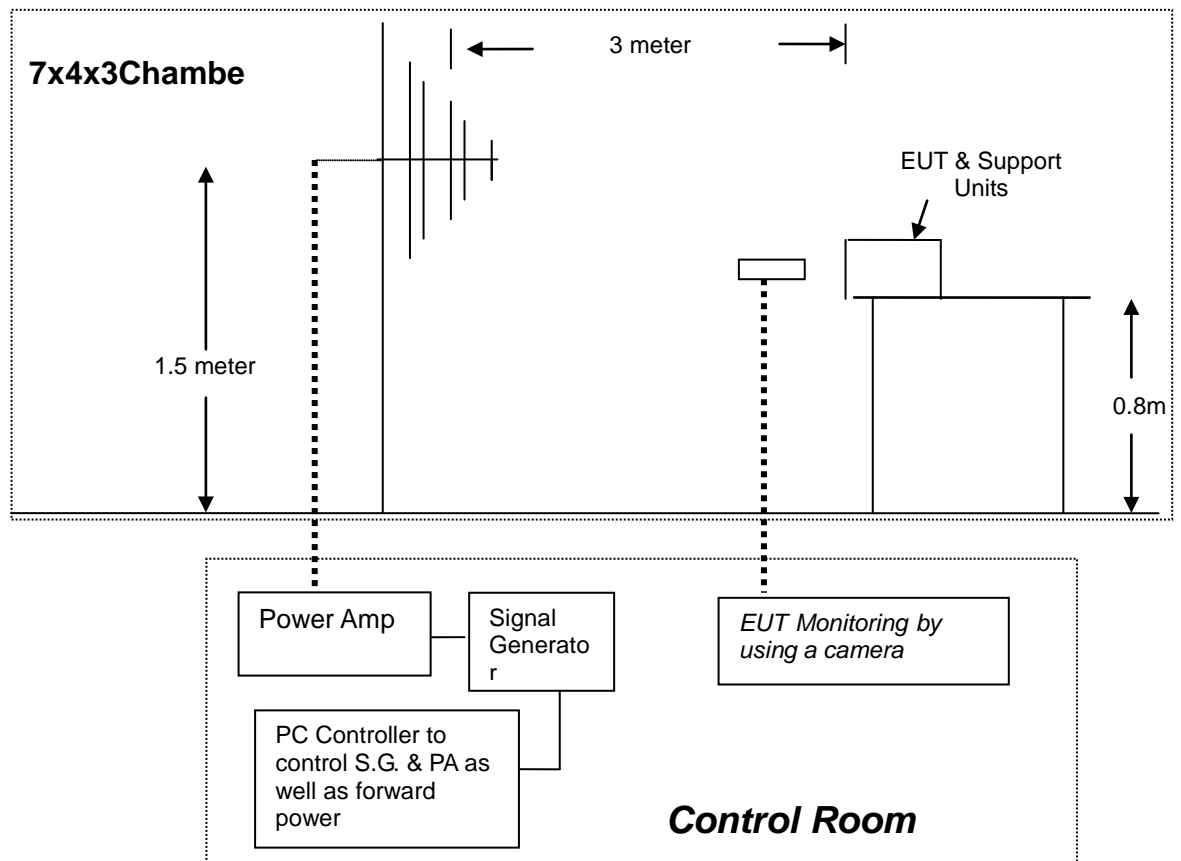

(EUT: Uninterruptible Power Systems)

9.2. Test Standard

EN62040-2:2006 (EN61000-4-3: 2006+A1:2008+A2:2010, Severity Level: 3, 10V / m)

9.3. Severity Levels and Performance Criterion

9.3.1. Severity Levels

Level	Field Strength V/m
1.	1
2.	3
3.	10
X	Special

9.3.2. Performance Criterion: A

9.4. EUT Configuration on Test

The configuration of the EUT is same as Section 4.3.

9.5. Operating Condition of EUT

Same as radiated emission measurement that is listed in Section 4.4, except the test setup replaced as Section 9.1.

9.6. Test Procedure

The EUT are placed on a table that is 0.8 meter high above the ground. The EUT is set 3 meters away from the transmitting antenna that is mounted on an antenna tower. Both horizontal and vertical polarization of the antenna is set on test. Each of the four sides of the EUT must be faced this transmitting antenna and measured individually.

In order to judge the EUT performance, a CCD camera is used to monitor it.

All the scanning conditions are as following:

Condition of Test	Remark
1. Fielded Strength	10V/m (Severity Level 3)
2. Radiated Signal	Modulated
3. Scanning Frequency	80-1000MHz
4. Sweep time of radiated	0.0015 Decade/s
5. Dwell Time	1 Sec.

9.7. Test Results

PASS.

Please refer to the following page.

RF Field Strength Susceptibility Test Results

EMTEK (SHENZHEN) CO., LTD.

Applicant : INVT POWER SYSTEM (SHENZHEN) CO., LTD.				
EUT	: Uninterruptible Power Systems	Test Date	: December 28, 2015	
M/N	: RM040/10X	Temperature	: 22°C	
Field Strength	: 10 V/m	Humidity	: 50 %	
Power Supply	: AC 380V / 50Hz	Criterion	: A	
Test Mode	: Line mode/ Battery mode	Frequency Range	: 80 MHz to1000 MHz	
Modulation: <input type="checkbox"/> None <input type="checkbox"/> Pulse <input checked="" type="checkbox"/> AM 1KHz 80%				
Frequency Rang 1: 80~ 1000MHz		Frequency Rang 2: N/A		
Steps	1%			
	Horizontal	Vertical	Horizontal	Vertical
Front	A	A		
Right	A	A		
Rear	A	A		
Left	A	A		
Test Equipment: 1. Signal Generator: 2023B (AEROFLEX) 2. Power Amplifier: AS0102-55 (MILMEGA)&AP32MT215 (PRANA) 3. Log.-Per.Antenna: VULP9118E(SCHWARZBECK) 4. Broad-Band Horn Antenna: BBHA 9120L3F(SCHWARZBECK) 5. RF Power Meter. Dual Channel: 4232A(BOONTON) 6. Field Strength Meter: HI-6005 (HOLADAY)				
Note:				

10. ELECTRICAL FAST TRANSIENT/BURST IMMUNITY TEST

10.1. Block Diagram of Test Setup

10.1.1. Block Diagram of the EUT.



(EUT: Uninterruptible Power Systems)

10.1.2. EFT Test Setup

AC Port:

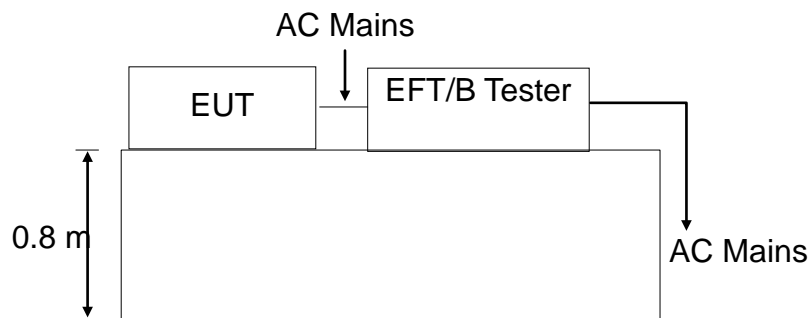

(EUT: Uninterruptible Power Systems)

10.2. Test Standard

EN62040-2:2006 (EN61000-4-4: 2012, Severity Level: 3, 2KV)

10.3. Severity Levels and Performance Criterion

10.3.1. Severity level

Level	Open Circuit Output Test Voltage $\pm 10\%$	
	On Power Supply Lines	On I/O (Input/Output) Signal data and control lines
1	0.5 KV	0.25 KV
2	1 KV	0.5 KV
3	2 KV	1 KV
4	4 KV	2 KV
X	Special	Special

10.3.2. Performance criterion: B

10.4. EUT Configuration

The configuration of EUT is listed in Section 4.3.

10.5.Operating Condition of EUT

- 10.5.1.Setup the EUT as shown in Section 10.1.
- 10.5.2.Turn on the power of all equipments.
- 10.5.3.Let the EUT work in test mode (Line mode) and measure it.

10.6.Test Procedure

The EUT is put on the table that is 0.8 meter high above the ground. This reference ground plane shall project beyond the EUT by at least 0.1m on all sides and the minimum distance between EUT and all other conductive structure, except the ground plane beneath the EUT, shall be more than 0.5m.

10.6.1.For input and output AC power ports:

The EUT is connected to the power mains by using a coupling device that couples the EFT interference signal to AC power lines. Both polarities of the test voltage should be applied during compliance test and the duration of the test is 2 mins.

10.6.2.For signal lines and control lines ports:

It's unnecessary to test.

10.6.3.For DC output line ports:

It's unnecessary to test.

10.7.Test Result

PASS.

Please refer to the following page.

Electrical Fast Transient/Burst Test Results

EMTEK (SHENZHEN) CO., LTD.

Standard : <input type="checkbox"/> EN 61000-4-4		Result: <input checked="" type="checkbox"/> PASS / <input type="checkbox"/> FAIL	
Applicant : <u>INVT POWER SYSTEM (SHENZHEN) CO., LTD.</u> EUT : <u>Uninterruptible Power Systems</u> M/N : <u>RM040/10X</u> Input Voltage: <u>AC 380V / 50Hz</u> Criterion : B Ambient Condition : <u>22 °C</u> <u>50% RH</u>			
Operation Mode: Line mode			
Line : <input checked="" type="checkbox"/> AC Mains		Line : <input type="checkbox"/> Signal <input type="checkbox"/> I/O Cable	
Coupling : <input checked="" type="checkbox"/> Direct		Coupling : <input type="checkbox"/> Capacitive	
Test Time : 120s			
Line	Test Voltage	Result(+)	Result(-)
L1, L2, L3, PE	2kV	A	A
L1-L2, L1-L3, L2-L3	2kV	A	A
L1-PE, L2-PE, L3-PE,	2kV	A	A
L1-L2- PE, L1-L3- PE, L2-L3- PE, L1-L2-L3	2kV	A	A
L1-L2-L3-PE	2kV	A	A
Signal Line			
DC Line			
Note:			
Test Equipment		Burst Tester Model : PEFT 4010	

11. SURGE IMMUNITY TEST

11.1. Block Diagram of Test Setup

11.1.1. Block Diagram of the EUT.



(EUT: Uninterruptible Power Systems)

11.1.2. Surge Test Setup

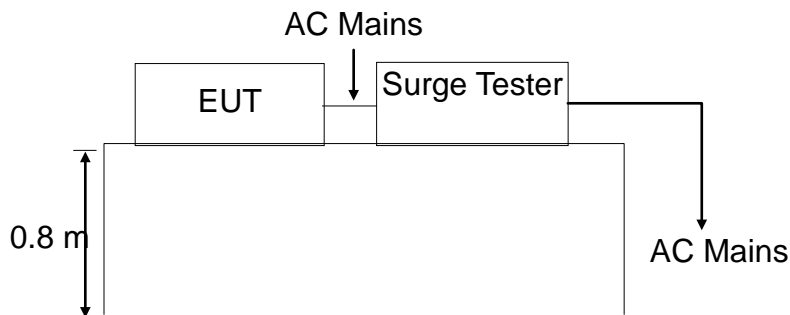

11.2. Test Standard

EN62040-2:2006
(EN61000-4-5: 2006, Line to Line: Severity Level 2, 1.0KV;
Line to earth: Severity Level 3: 2.0KV)

11.3. Severity Levels and Performance Criterion

11.3.1. Severity level

Severity Level	Open-Circuit Test Voltage KV
1	0.5
2	1.0
3	2.0
4	4.0
*	Special

11.3.2. Performance criterion: A

11.4. EUT Configuration

The configuration of EUT is listed in Section 4.3.

11.5. Operating Condition of EUT

- 11.5.1. Setup the EUT as shown in Section 11.1.
- 11.5.2. Turn on the power of all equipments.
- 11.5.3. Let the EUT work in test mode (Line mode) and measure it.

11.6. Test Procedure

- 11.6.1. Set up the EUT and test generator as shown on Section 11.1.2.
- 11.6.2. For line to line coupling mode, provide 1.0 KV (1.2/50us) voltage surge,
For line to earth coupling mode, provide 2.0 KV (1.2/50us) voltage surge (At open-circuit condition). At least 5 positive and 5 negative (polarity) tests with a maximum 1/min repetition rate are conducted during test.
- 11.6.3. Different phase angles are done individually.
- 11.6.4. Record the EUT operating situation during compliance test and decide the EUT immunity criterion for above each test.

11.7. Test Result

PASS.

Please refer to the following page.

Surge Immunity Test Result

EMTEK (SHENZHEN) CO., LTD.

Applicant : <u>INVT POWER SYSTEM (SHENZHEN) CO., LTD.</u>			Test Date : <u>December 28, 2015</u>		
EUT : <u>Uninterruptible Power Systems</u>			Temperature : 22°C		
M/N : <u>RM040/10X</u>			Humidity : 50%		
Power Supply : <u>AC 380V / 50Hz</u>			Criterion : B		
Test Mode : <u>Line mode</u>					
Location	Polarity	Phase Angle	Number of Pulse	Pulse Voltage (kV)	Result
L1-L2, L1-L3, L2-L3	+	0°, 90°, 180°, 270°	5	1.0	A
	-	0°, 90°, 180°, 270°	5	1.0	A
L1-N, L2-N, L3-N	+	0°, 90°, 180°, 270°	5	1.0	A
	-	0°, 90°, 180°, 270°	5	1.0	A
L1-PE, L2-PE, L3-PE	+	0°, 90°, 180°, 270°	5	2.0	A
	-	0°, 90°, 180°, 270°	5	2.0	A
N-PE	+	0°, 90°, 180°, 270°	5	2.0	A
	-	0°, 90°, 180°, 270°	5	2.0	A
				Test Equipment:PIM100, PCD130 Surge Tester: King	

12. INJECTED CURRENTS SUSCEPTIBILITY TEST

12.1. Block Diagram of Test Setup

12.1.1. Block Diagram of the EUT.



(EUT: Uninterruptible Power Systems)

12.1.2. Block Diagram of Test Setup

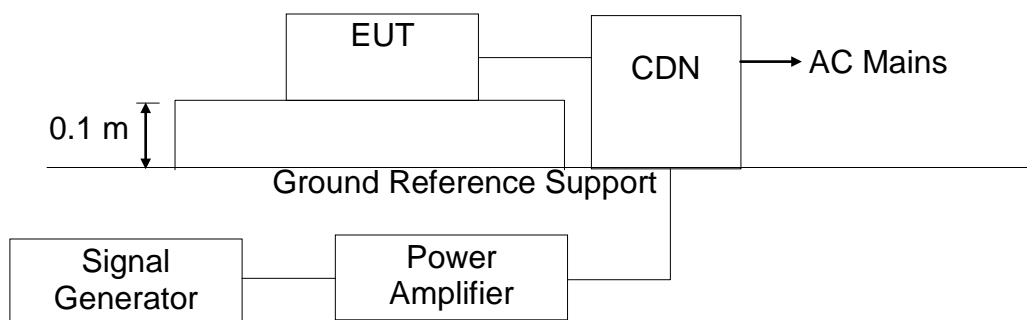

(EUT: Uninterruptible Power Systems)

12.2. Test Standard

EN62040-2:2006

(EN61000-4-6: 2009, Severity Level: Level 3, 10V (r.m.s.), 0.15MHz ~ 80MHz)

12.3. Severity Levels and Performance Criterion

12.3.1. Severity level

Level	Field Strength V
1	1
2	3
3	10
X	Special

12.3.2. Performance criterion: A

12.4. EUT Configuration

The configuration of EUT is listed in Section 4.3.

12.5. Operating Condition of EUT

- 12.5.1. Setup the EUT as shown in Section 12.1.
- 12.5.2. Turn on the power of all equipments.
- 12.5.3. Let the EUT work in test mode (Line mode) and measure it.

12.6. Test Procedure

- 12.6.1. Set up the EUT, CDN and test generators as shown on Section 12.1.2.
- 12.6.2. Let the EUT work in test mode and measure it.
- 12.6.3. For AC Mains: The EUT are placed on an insulating support 0.1m high above a ground reference plane. CDN (coupling and decoupling device) is placed on the ground plane about 0.3m from EUT. Cables between CDN and EUT are as short as possible, and their height above the ground reference plane shall be between 30 and 50 mm (where possible). The disturbance signal described below is injected to EUT through CDN. The EUT operates within its operational mode(s) under intended climatic conditions after power on.
- 12.6.4. The frequency range is swept from 150KHz to 80MHz using 10V signal level, and with the disturbance signal 80% amplitude modulated with a 1KHz sine wave.
- 12.6.5. The rate of sweep shall not exceed $1.5 \cdot 10^{-3}$ decades/s. where the frequency is swept incrementally; the step size shall not exceed 1% of the start and thereafter 1% of the preceding frequency value.
- 12.6.6. Recording the EUT operating situation during compliance testing and decide the EUT immunity criterion.

12.7. Test Results

PASS.

Please refer to the following page.

Injected Currents Susceptibility Test Results

EMTEK (SHENZHEN) CO., LTD.

Applicant : <u>INVT POWER SYSTEM (SHENZHEN) CO., LTD.</u>				
EUT : <u>Uninterruptible Power Systems</u>		Test Date: <u>December 28, 2015</u>		
M/N : <u>RM040/10X</u>		Temperature : <u>22°C</u>		
Power Supply : <u>AC 380V / 50Hz</u>		Humidity : <u>58%</u>		
Test Engineer : <u>LB</u>				
Test Mode: <u>Line mode</u>				
Frequency Range (MHz)	Injected Position	Strength (Unmodulated)	Criterion	Result
0.15 ~ 80	AC Mains	10V	A	A
Test Mode : <u>N/A</u>				
Frequency Range (MHz)	Injected Position	Strength (Unmodulated)	Criterion	Result
Remark : 1. Modulation Signal:1KHz 80% AM Measurement Equipment : Simulator: CWS 500 (SWITZERLAND EMTEST) CDN : <input type="checkbox"/> CDN-M2 (SWITZERLAND EMTEST) <input type="checkbox"/> CDN-M3 (SWITZERLAND EMTEST) <input checked="" type="checkbox"/> Injection Clamp(EMTEST F-2031-23MM)		Note:		

13. MAGNETIC FIELD SUSCEPTIBILITY TEST

13.1. Block Diagram of Test

13.1.1. Block diagram of test setup.



(EUT: Uninterruptible Power Systems)

13.1.2. Magnetic field test setup

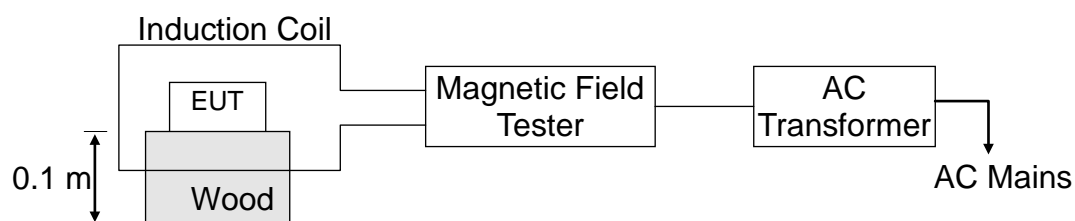

(EUT: Uninterruptible Power Systems)

13.2. Test Standard

EN62040-2:2006
(EN61000-4-8: 2010, Severity Level: Level 3, 10A / m)

13.3. Severity Levels and Performance Criterion

13.3.1. Severity Levels

Level	Field Strength A/m
1	1
2	3
3	10
4	30
5	100
X	Special

13.3.2. Performance Criterion: A

13.4. EUT Configuration on Test

The configuration of the EUT is same as Section 4.3.

13.5.Test Procedure

The EUT is placed in the middle of a induction coil (1*1m), under which is a 1*1*0.1m (high) table, this small table is also placed on a larger table, 0.8 m above the ground. Both horizontal and vertical polarization of the induction coil is set on test, so that each side of the EUT is affected by the magnetic field. Also can reach the same aim by change the position of the EUT.

13.6.Test Results

PASS.

Please refer to the following page.

Magnetic Field Immunity Test Result

EMTEK (SHENZHEN) CO., LTD.

Standard: <input checked="" type="checkbox"/> EN 61000-4-8	Result: <input checked="" type="checkbox"/> PASS / <input type="checkbox"/> FAIL			
Applicant : <u>INVT POWER SYSTEM (SHENZHEN) CO., LTD.</u> EUT : <u>Uninterruptible Power Systems</u> M/N : <u>RM040/10X</u> Input Voltage : <u>AC380V/50Hz</u> Date of Test : <u>December 28, 2015</u> Test Engineer: <u>LB</u> Ambient Condition : Temp : <u>22°C</u> Humid: <u>50%</u> Criterion: A				
Operation Mode: Line mode				
Test Level (A/M)	Testing Duration	Coil Orientation	Criterion	Result
30	5 mins	X	A	A
30	5 mins	Y	A	A
30	5 mins	Z	A	A
Operation Mode: N/A				
Test Level (A/M)	Testing Duration	Coil Orientation	Criterion	Result
Test Equipment	Magnetic Field Test: HEAFELY MAG 100.1			
Note:				

14. VOLTAGE DIPS AND INTERRUPTIONS TEST

14.1. Block Diagram of Test Setup

14.1.1. Block Diagram of the EUT.



(EUT: Uninterruptible Power Systems)

14.1.2. Dips Test Setup

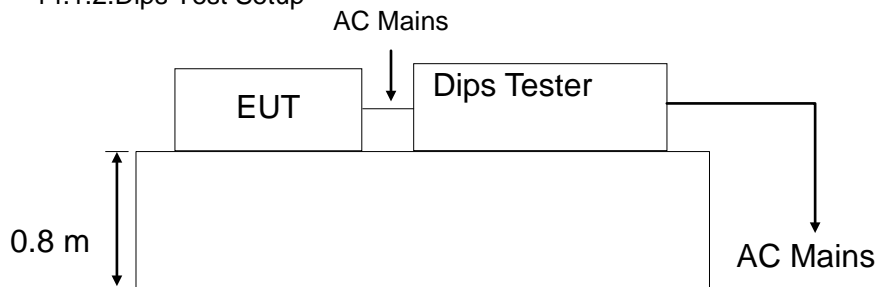

(EUT: Uninterruptible Power Systems)

14.2. Test Standard

EN62040-2:2006 (EN61000-4-11: 2004, Class 3)

14.3. Severity Levels and Performance Criterion

14.3.1. Severity level

Test Level %UT	Voltage dip and short interruptions %UT	Duration (in period)
0	100	0.5
0	100	1
40	60	12
70	30	30
80	20	300

14.3.2. Performance criterion: B&C

14.4. EUT Configuration

The configuration of EUT is listed in Section 4.3.

14.5.Operating Condition of EUT

- 14.5.1.Setup the EUT as shown in Section 14.1.
- 14.5.2.Turn on the power of all equipments.
- 14.5.3.Let the EUT work in test mode (Line mode) and measure it.

14.6.Test Procedure

- 14.6.1.Set up the EUT and test generator as shown on Section 14.1.2.
- 14.6.2.The interruption is introduced at selected phase angles with specified duration.
- 14.6.3.Record any degradation of performance.

14.7.Test Result

PASS.

Please refer to the following page.

Voltage Dips and Interruptions Test Results

EMTEK (SHENZHEN) CO., LTD.

Applicant : <u>INVT POWER SYSTEM (SHENZHEN) CO., LTD.</u>				
EUT : <u>Uninterruptible Power Systems</u>			Test Date : <u>December 28, 2015</u>	
M/N : <u>RM040/10X</u>			Temperature : <u>22°C</u>	
Power Supply : <u>AC 380V / 50Hz</u>			Humidity : <u>50%</u>	
Test Mode: <u>Line mode</u>				
Test Level % U _T	Voltage Dips & Short Interruptions % U _T	Duration (in periods)	Criterion <input checked="" type="checkbox"/> A <input type="checkbox"/> B <input type="checkbox"/> C <input type="checkbox"/> D	Result P=PASS F=FAIL
0	100	0.5p	A	P
0	100	1 p	A	P
40	60	12 p	A	P
70	30	30 p	A	P
80	20	300 p	A	P
Test Mode : <u>N/A</u>				
Test Level % U _T	Voltage Dips & Short Interruptions % U _T	Duration (in periods)	Criterion <input type="checkbox"/> A <input type="checkbox"/> B <input type="checkbox"/> C <input type="checkbox"/> D	Result P=PASS F=FAIL
Note:				

15. LOW FREQUENCY SIGNALS TEST

15.1. Block Diagram of Test Setup

15.1.1. Block Diagram of the EUT

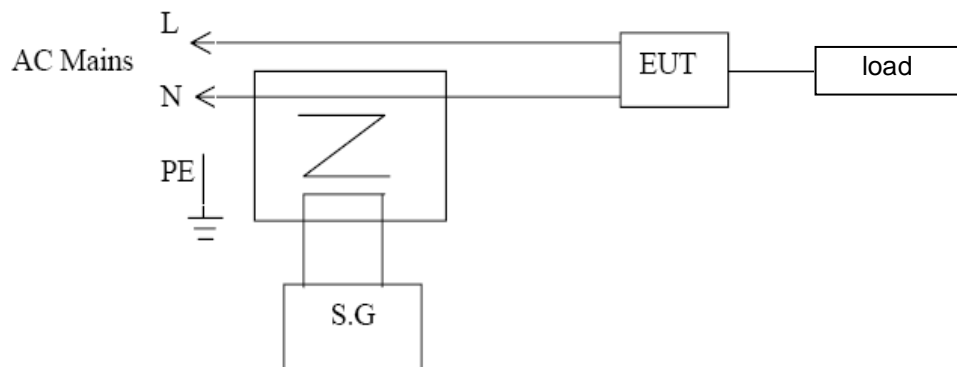

(EUT: Uninterruptible Power Systems)

15.1.2. Block Diagram of Test Setup

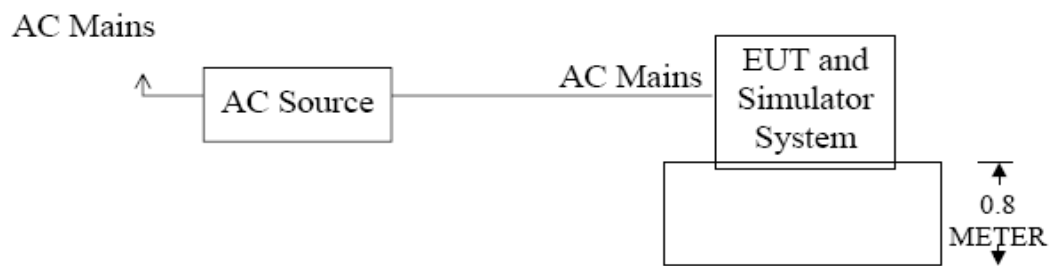

(EUT: Uninterruptible Power Systems)

15.2. Test Standard

EN61000-2-2: 2002, Performance: A

15.3. Operating Condition of EUT

Same as Section 4.5, Except the test setup replaced by Section 15.1.

15.4. Test Results

PASS.

Please refer to following pages.

Low Frequency Signals Test Result

EMTEK (SHENZHEN) CO., LTD.

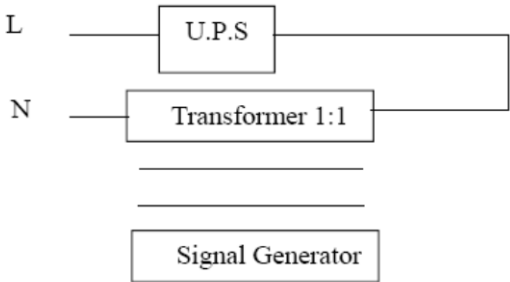
Applicant : <u>INVT POWER SYSTEM (SHENZHEN) CO., LTD.</u> EUT : <u>Uninterruptible Power Systems</u> M/N : <u>RM040/10X</u> Power Supply : <u>AC380V/50Hz</u> Test Engineer : <u>LB</u>			Test Date: <u>December 28, 2015</u> Temperature : <u>22°C</u> Humidity : <u>58%</u> Test Mode : <u>Line mode</u>	
Frequency Range (Hz)	Position	Strength	Result	Note
140	See Fig.1	10V(rms) Sinusoidal	PASS	
160			PASS	
200			PASS	
240			PASS	
280			PASS	
320			PASS	
360			PASS	
Note 			Test Equipment: 1. Isolation transformer Primary: Secondary=1:1 2. Signal Generator AC Source: 65930(Chroma)	

16. PHOTOGRAPH

16.1. Photo of Conducted Emission Measurement



16.2. Photo of Radiation Emission Measurement

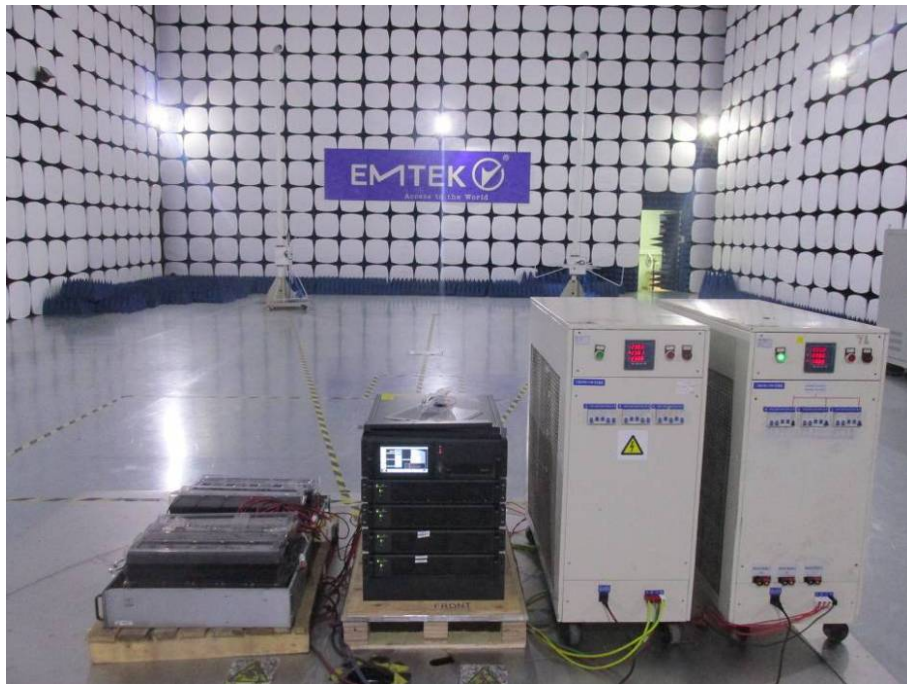

16.3. Photo of RF Field Strength Susceptibility Test

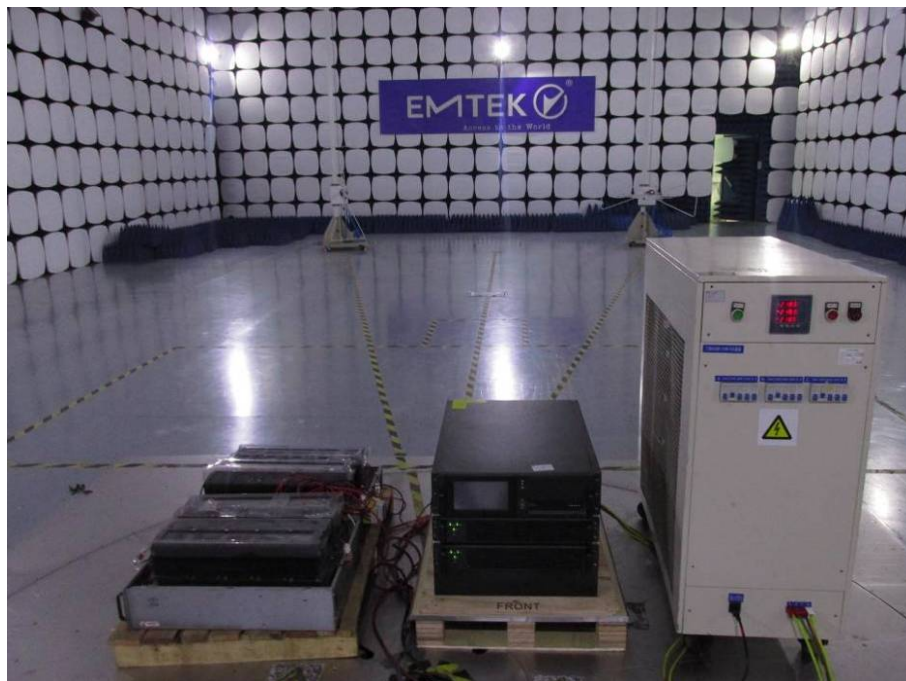

16.4.For Harmonic Current / Flicker Measurement



16.5.Photo of Electrostatic Discharge Test



16.6.Photo of RF Field Strength Susceptibility Test



16.7.Photo of Electrical Fast Transient / Burst Test



16.8.Photo of Surge Test



16.9.Photo of Injected Currents Susceptibility Test



16.10.Photo of Magnetic Field Immunity Test



16.11.Photo of Voltage Dips and Interruption Immunity Test



16.12.Photo of Low Frequency Signals Test



APPENDIX (Photos of EUT)







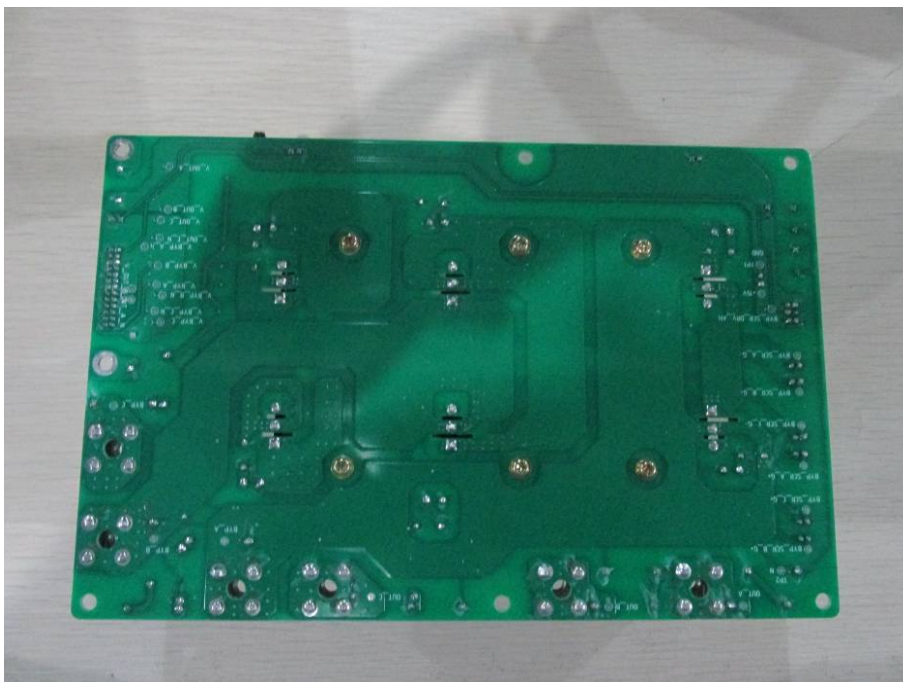

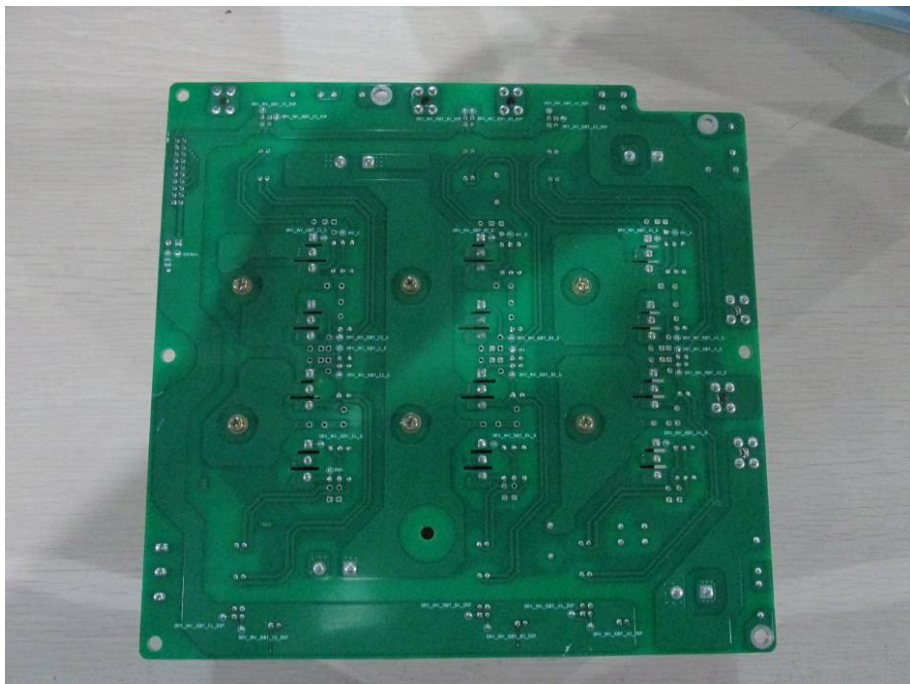
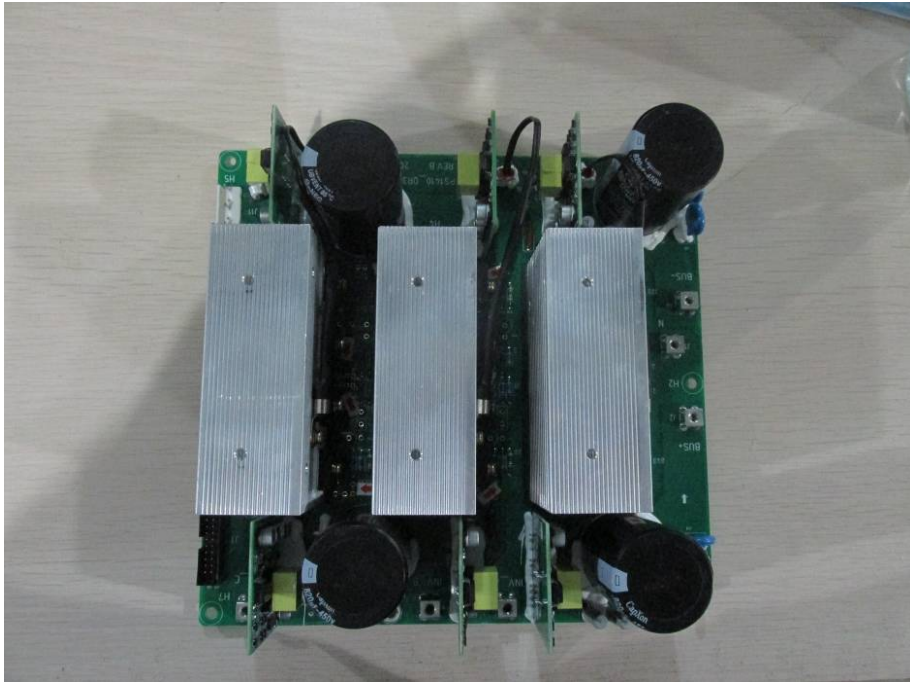

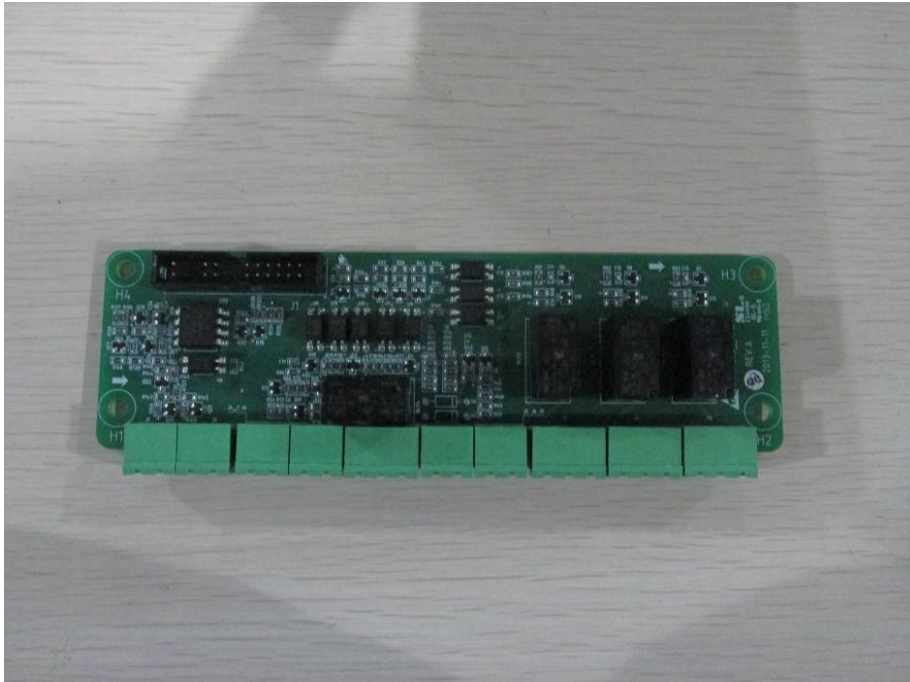

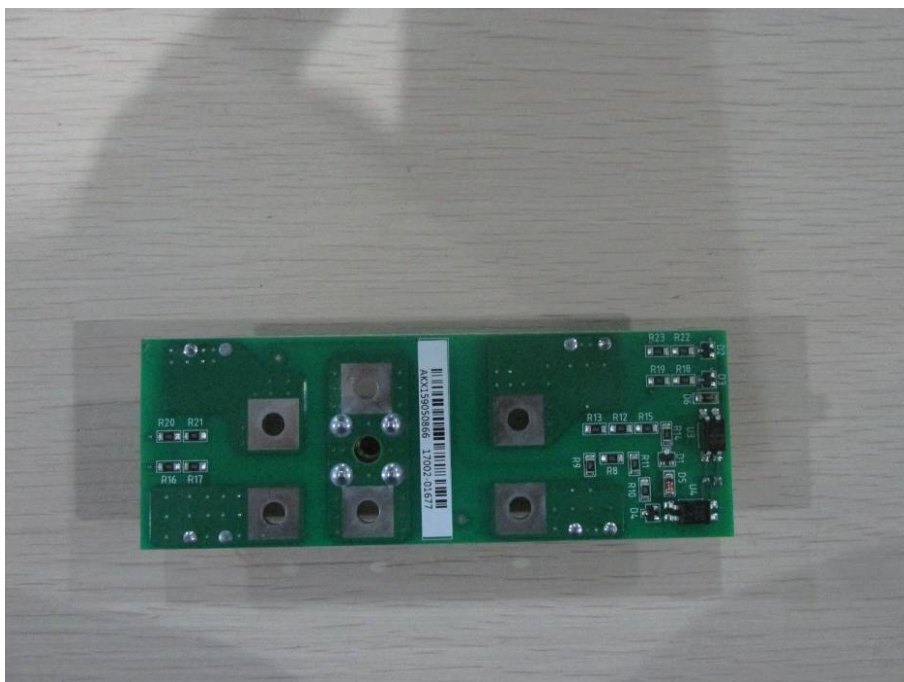
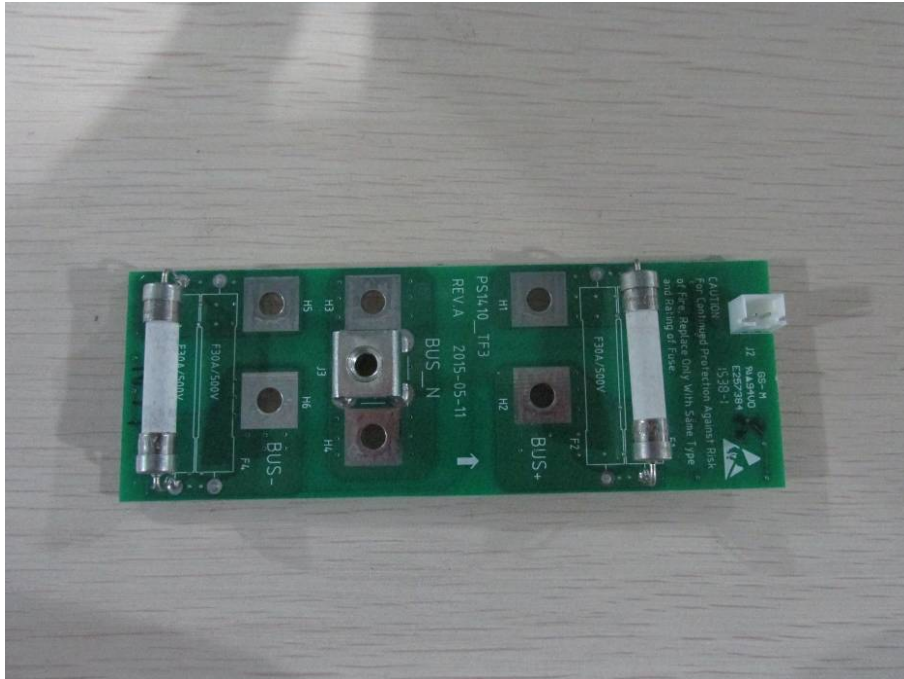

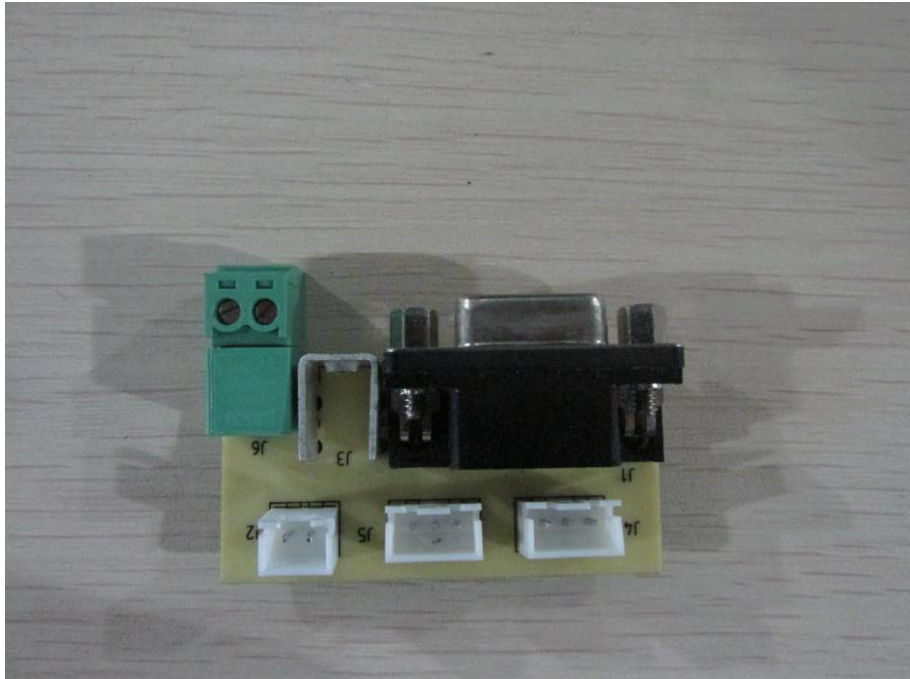

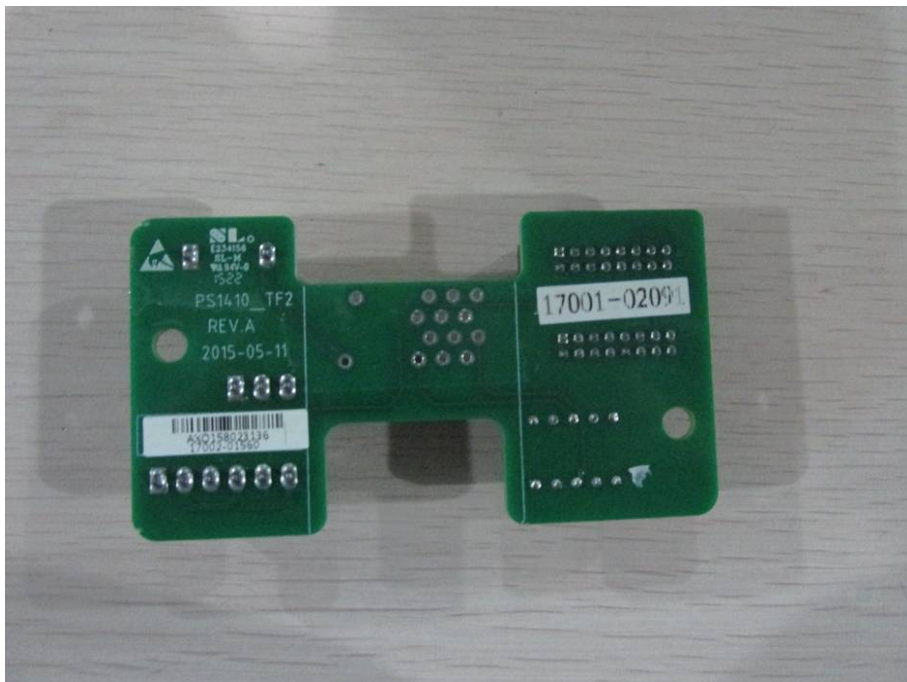

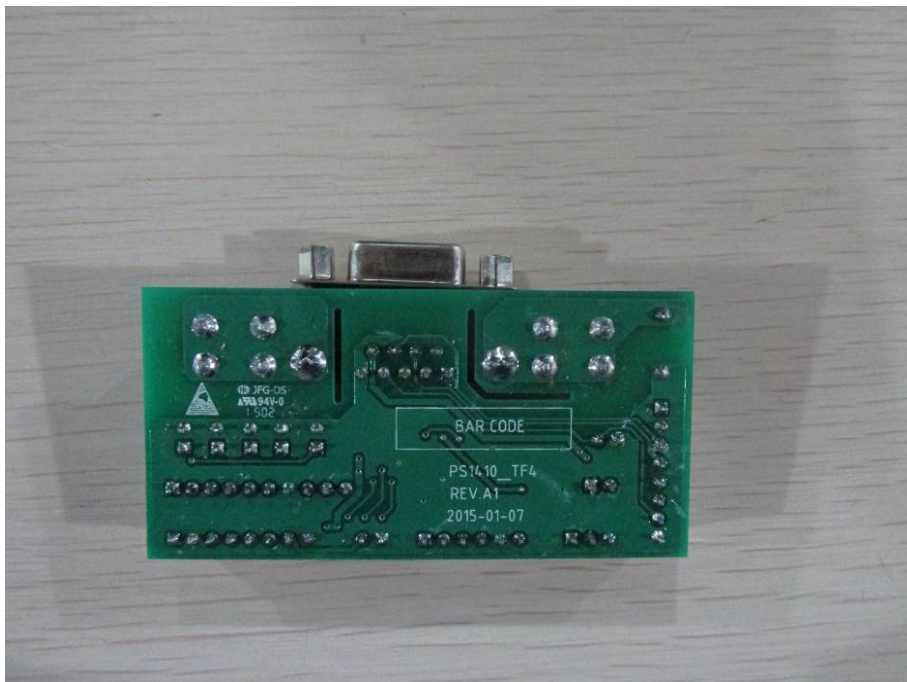
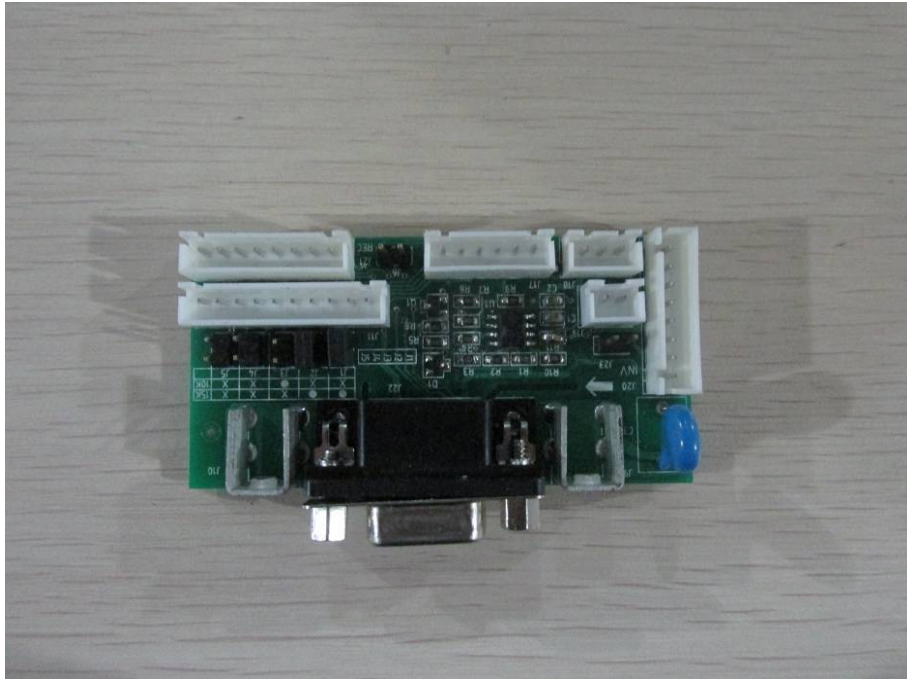

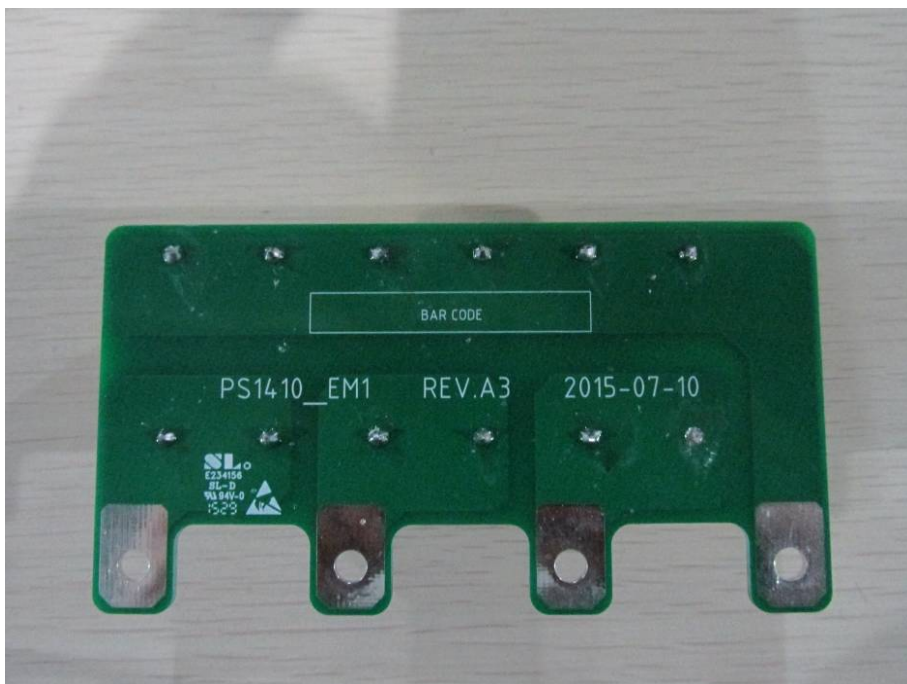
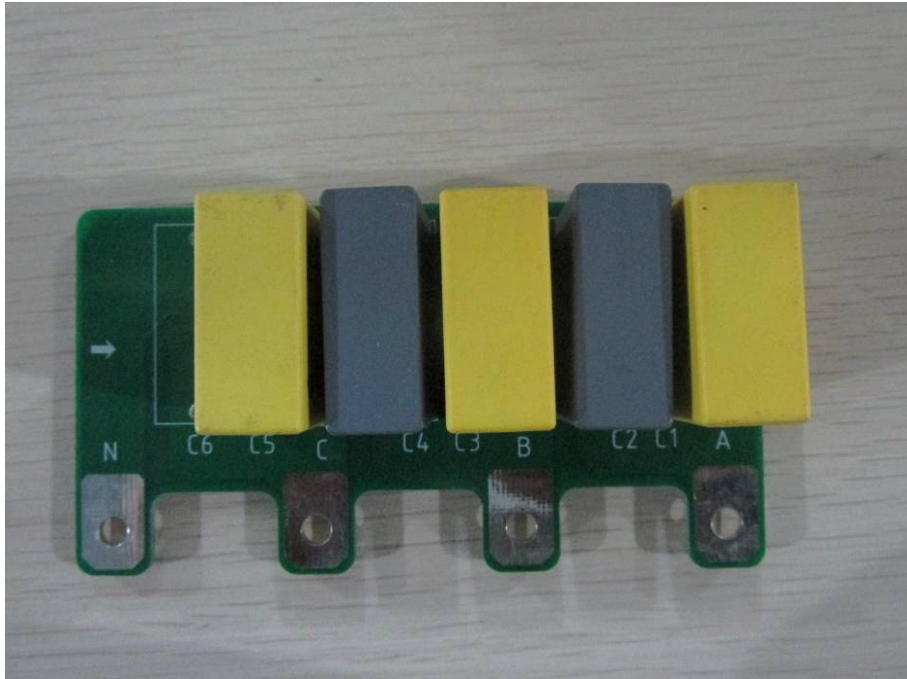

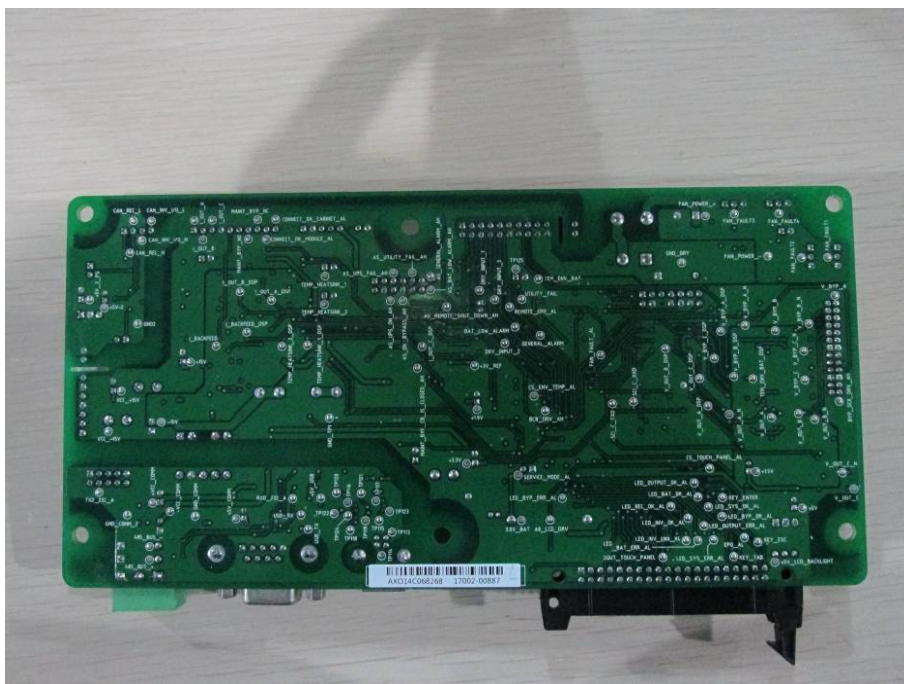
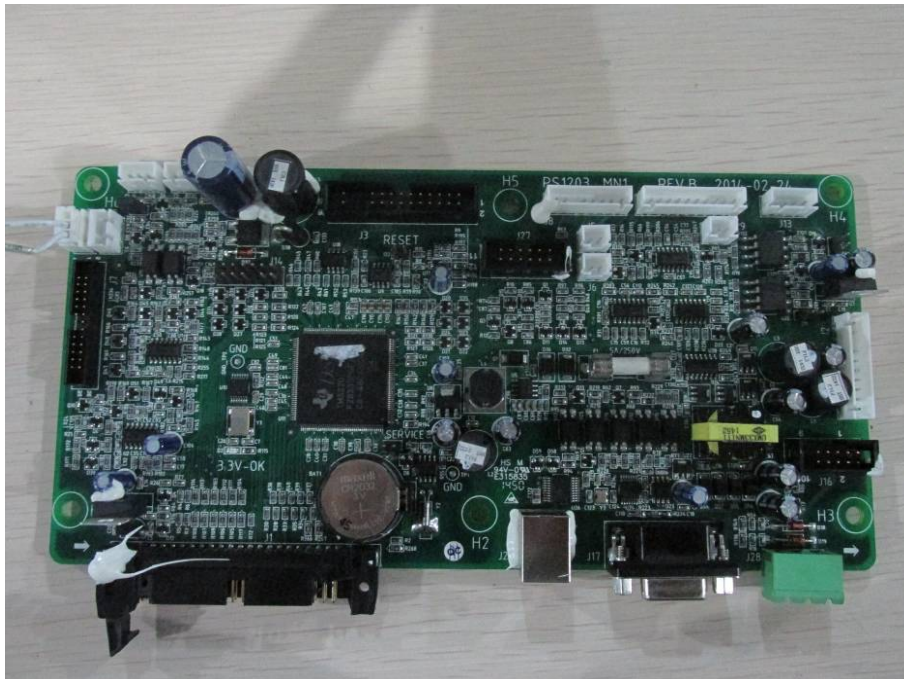

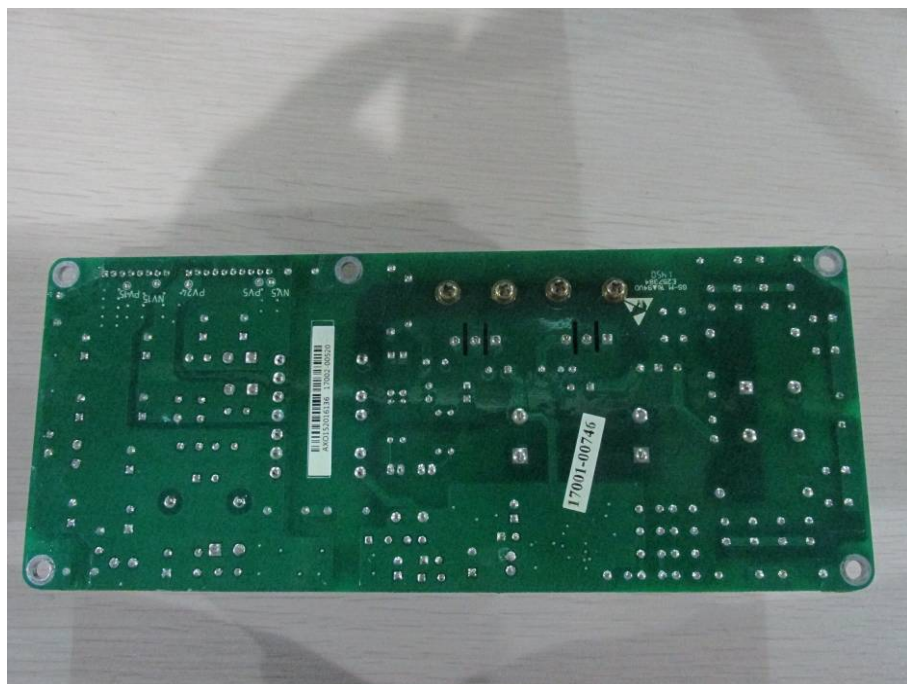

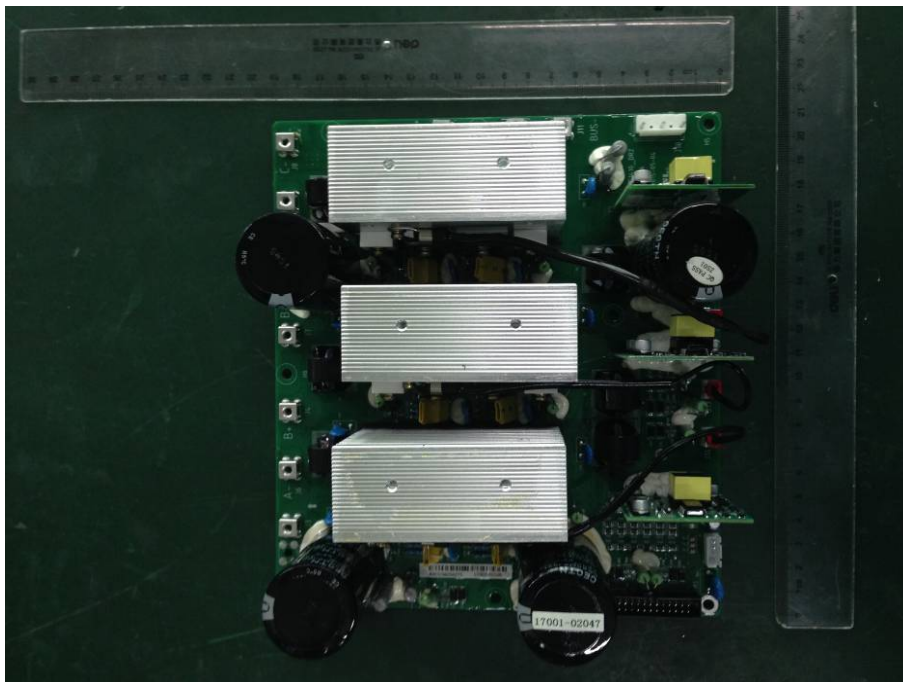
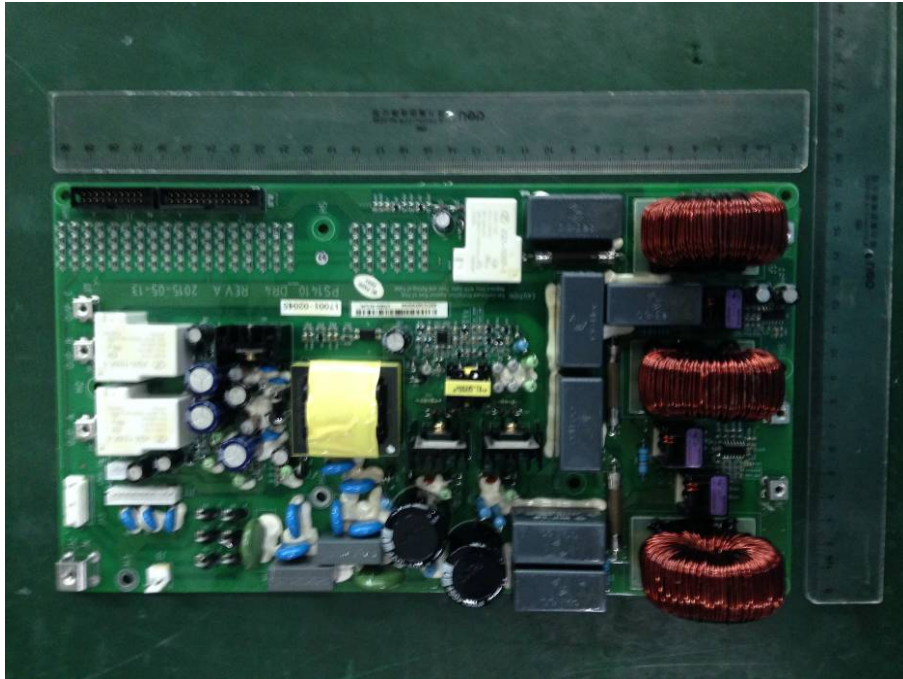

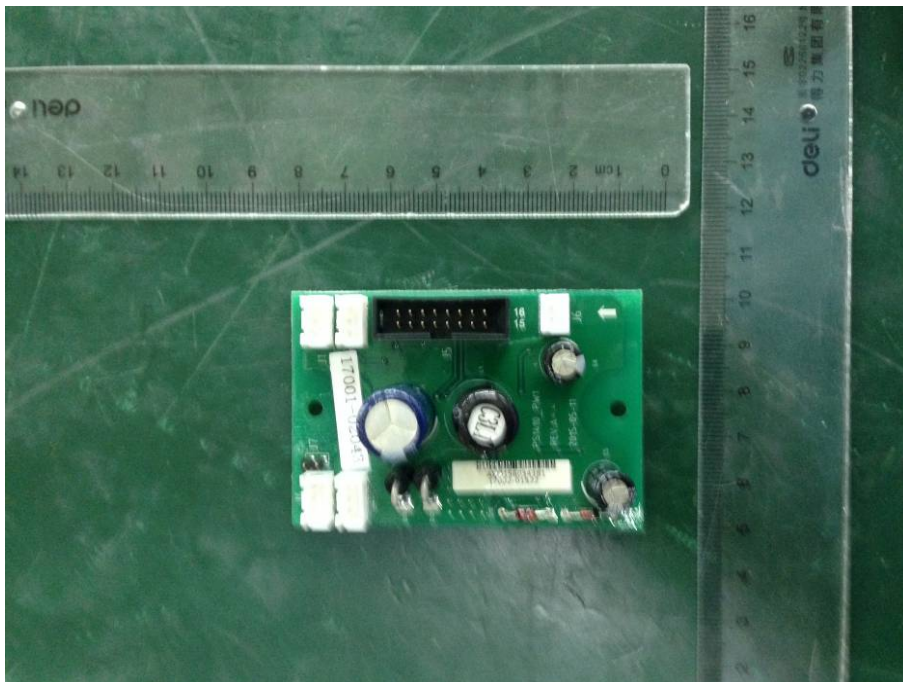
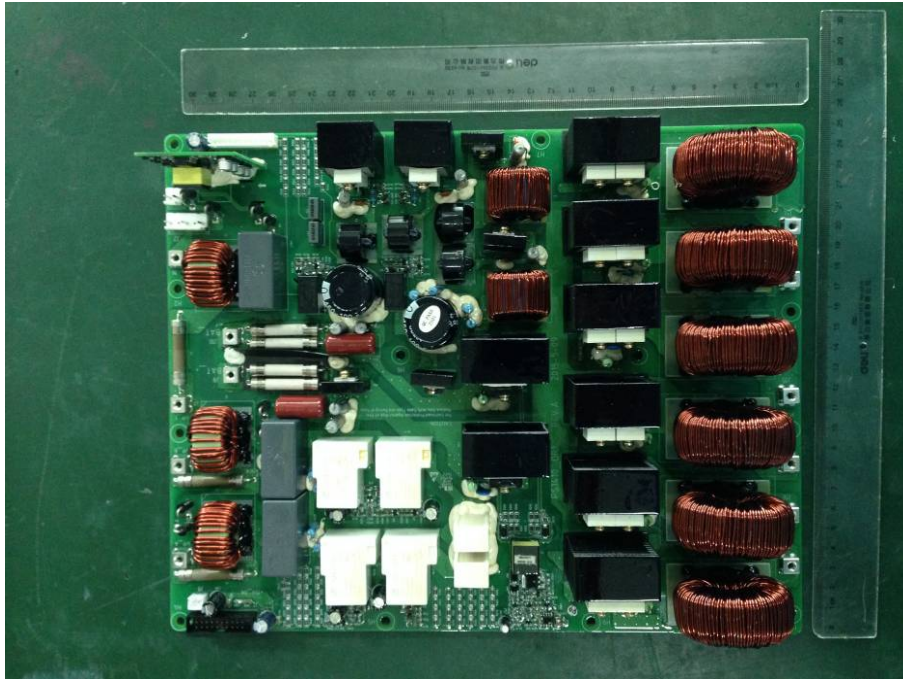

-----The end-----