

# EMC TEST REPORT For

INVT POWER SYSTEM (SHENZHEN) CO., LTD.

Uninterruptible Power Systems

Model Number: PM40X, PM50X

Prepared for : INVT POWER SYSTEM (SHENZHEN) CO., LTD.  
Address : 5th Floor, 1#Building, Gaofa Industrial Park, LongJing,  
Nanshan District, Shenzhen, China, 518055

Prepared by : EMTEK (SHENZHEN) CO., LTD.  
Address : Bldg 69, Majialong Industry Zone,  
Nanshan District, Shenzhen, Guangdong, China

Tel: (0755) 26954280  
Fax: (0755) 26954282

Report Number : ES160617013E  
Date of Test : August 03, 2016 to August 23, 2016  
Date of Report : August 24, 2016

## TABLE OF CONTENT

Description	Page
<b>1. SUMMARY OF TEST RESULT.....</b>	<b>6</b>
<b>2. GENERAL INFORMATION.....</b>	<b>7</b>
2.1. Description of Device (EUT).....	7
2.2. Description of Support Device.....	8
2.3. Description of Test Facility.....	8
2.4. Measurement Uncertainty.....	8
<b>3. MEASURING DEVICE AND TEST EQUIPMENT.....</b>	<b>9</b>
3.1. For Conducted Emission Measurement.....	9
3.2. For Radiated Emission Measurement.....	9
3.3. For Electrostatic Discharge Immunity Test.....	9
3.4. For RF Strength Susceptibility Test.....	10
3.5. For Electrical Fast Transient /Burst Immunity Test.....	10
3.6. For Surge Immunity Test.....	10
3.7. For Injected Current Susceptibility Test.....	10
3.8. For Magnetic Field Immunity Test.....	11
3.9. For Voltage Dips and Interruptions Test.....	11
3.10. Low Frequency Signals Test.....	11
<b>4. CONDUCTED EMISSION MEASUREMENT.....</b>	<b>12</b>
4.1. Block Diagram of Test Setup.....	12
4.2. Measuring Standard.....	12
4.3. Power Line Conducted Emission Limits (C3).....	12
4.4. EUT Configuration on Measurement.....	12
4.5. Operating Condition of EUT.....	13
4.6. Test Procedure.....	13
4.7. Measuring Results.....	13
<b>5. RADIATED EMISSION MEASUREMENT.....</b>	<b>18</b>
5.1. Block Diagram of Test Setup.....	18
5.2. Measuring Standard.....	18
5.3. Radiated Emission Limits (C3).....	18
5.4. EUT Configuration on Measurement.....	19
5.5. Operating Condition of EUT.....	19
5.6. Test Procedure.....	19
5.7. Measuring Results.....	19
<b>6. IMMUNITY PERFORMANCE CRITERIA DESCRIPTION.....</b>	<b>22</b>
<b>7. ELECTROSTATIC DISCHARGE IMMUNITY TEST.....</b>	<b>24</b>
7.1. Block Diagram of Test Setup.....	24
7.2. Test Standard.....	24
7.3. Severity Levels and Performance Criterion.....	24
7.4. Operating Condition of EUT.....	25
7.5. Test Procedure.....	25
7.6. Test Results.....	25
<b>8. RF FIELD STRENGTH SUSCEPTIBILITY TEST.....</b>	<b>27</b>
8.1. Block Diagram of Test Setup.....	27
8.2. Test Standard.....	27
8.3. Severity Levels and Performance Criterion.....	28
8.4. Operating Condition of EUT.....	28
8.5. Test Procedure.....	28
8.6. Test Results.....	28
<b>9. ELECTRICAL FAST TRANSIENT/BURST IMMUNITY TEST.....</b>	<b>30</b>

9.1. Block Diagram of Test Setup.....	30
9.2. Test Standard.....	30
9.3. Severity Levels and Performance Criterion.....	30
9.4. Operating Condition of EUT.....	31
9.5. Test Procedure.....	31
9.6. Test Results.....	31
<b>10. SURGE IMMUNITY TEST.....</b>	<b>33</b>
10.1. Block Diagram of Test Setup.....	33
10.2. Test Standard.....	33
10.3. Severity Levels and Performance Criterion.....	33
10.4. Operating Condition of EUT.....	33
10.5. Test Procedure.....	33
10.6. Test Results.....	34
<b>11. INJECTED CURRENTS SUSCEPTIBILITY TEST.....</b>	<b>36</b>
11.1. Block Diagram of Test Setup.....	36
11.2. Test Standard.....	36
11.3. Severity Levels and Performance Criterion.....	36
11.4. Operating Condition of EUT.....	37
11.5. Test Procedure.....	37
11.6. Test Results.....	37
<b>12. MAGNETIC FIELD SUSCEPTIBILITY TEST.....</b>	<b>39</b>
12.1. Block Diagram of Test Setup.....	39
12.2. Test Standard.....	39
12.3. Severity Levels and Performance Criterion.....	39
12.4. Operating Condition of EUT.....	40
12.5. Test Procedure.....	40
12.6. Test Results.....	40
<b>13. VOLTAGE DIPS AND INTERRUPTIONS TEST.....</b>	<b>42</b>
13.1. Block Diagram of Test Setup.....	42
13.2. Test Standard.....	42
13.3. Severity Levels and Performance Criterion.....	42
13.4. Operating Condition of EUT.....	43
13.5. Test Procedure.....	43
13.6. Test Result.....	43
<b>14. LOW FREQUENCY SIGNALS TEST.....</b>	<b>45</b>
14.1. Block Diagram of Test Setup.....	45
14.2. Test Standard.....	45
14.3. Operating Condition of EUT.....	45
14.4. Test Results.....	45
<b>15. TEST PHOTOGRAPH.....</b>	<b>50</b>
15.1. Photos of Conducted Emission Measurement.....	50
15.2. Photo of Radiation Emission Measurement.....	51
15.3. Photo of Electrostatic Discharge Test.....	52
15.4. Photo of RF Field Strength Susceptibility Test.....	52
15.5. Photo of Electrical Fast Transient / Burst Test.....	53
15.6. Photo of Surge Test.....	53
15.7. Photo of Injected Currents Susceptibility Test.....	54
15.8. Photo of Magnetic Field Immunity Test.....	54
15.9. Photo of Voltage Dips and Interruptions Test.....	55
15.10. Photo of Low Frequency Signals Test.....	55

APPENDIX (Photos of EUT) (12 Pages)

## TEST REPORT VERIFICATION

Applicant : INVT POWER SYSTEM (SHENZHEN) CO., LTD.  
 Manufacturer : INVT POWER SYSTEM (SHENZHEN) CO., LTD.  
 EUT : Uninterruptible Power Systems  
 Trademark : INVT  
 Model Number : PM40X, PM50X  
 Power Supply : Please refer to the page 7

### Measurement Procedure Used:

EN 62040-2:2006  
 (IEC 61000-4-2:2008, IEC 61000-4-3:2006+A1:2007+A2:2010,  
 IEC 61000-4-4:2012, IEC 61000-4-5:2014, IEC 61000-4-6:2013, IEC 61000-4-8:2009, IEC  
 61000-4-11:2004, EN61000-2-2: 2002, EN62040-2: 2006)

The device described above is tested by EMTEK (SHENZHEN) CO., LTD. to determine the maximum emission levels emanating from the device and the severe levels of the device can endure and its performance criterion. The measurement results are contained in this test report and EMTEK (SHENZHEN) CO., LTD. is assumed full of responsibility for the accuracy and completeness of these measurements. Also, this report shows that the EUT (Equipment Under Test) is technically compliant with the EN 62040-2 requirements.

This report applies to above tested sample only and shall not be reproduced in part without written approval of EMTEK (SHENZHEN) CO., LTD.

Date of Test : August 03, 2016 to August 23, 2016

Prepared by :   
Bunny Zhang/Editor

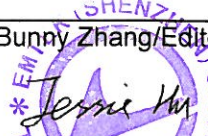
Reviewer :   
Jessie Hu/Supervisor

Approved & Authorized Signer :   
Lisa Wang/Manager

**Modified Information**

Version	Report No.	Revision Date	Summary
Ver.1.0	ES160617013E	/	Original Report

## 1. SUMMARY OF TEST RESULT

<b>EMISSION</b>			
Description of Test Item	Standard	Limits	Results
Conducted Disturbance at Mains Terminals and Telecommunication Ports	EN 62040-2:2006	C3	Pass
Radiated Disturbance	EN 62040-2:2006	C3	Pass
<b>IMMUNITY(C3)</b>			
Description of test Item	Basic Standard	Performance Criteria	Results
Electrostatic Discharge (ESD)	IEC 61000-4-2:2008	B	Pass
Radio-Frequency, Continuous Radiated Disturbance	IEC 61000-4-3:2006 +A1:2007+A2:2010	A	Pass
EFT/B Immunity	IEC 61000-4-4 :2004+A1:2010	B	Pass
Surge Immunity	IEC 61000-4-5:2014	B	Pass
Conducted RF Immunity	IEC 61000-4-6:2013	A	Pass
Power Frequency Magnetic Field	IEC 61000-4-8:2009	A	Pass
Voltage Dips	IEC 61000-4-11:2004	A	Pass
Low Frequency Signals	EN61000-2-2: 2002	A	Pass
Power Line Unbalance (Three-Phase Ups Systems Only)	EN62040-2: 2006	A	Pass
Note: N/A is an abbreviation for Not Applicable.			

## 2. GENERAL INFORMATION

### 2.1. Description of Device (EUT)

EUT	:	Uninterruptible Power Systems
Model Number	:	PM40X, PM50X (Note: All models have the same constructions, circuit diagram and PCB layout except their model model no. We prepare PM50X for EMC test.)
Input Rating	:	PM40X: AC Input: 380/400/415VAC, 3 $\phi$ +N+PE, 50Hz/60HZ 58Amax Batt. Input: $\pm$ 240VDC, 80Amax  PM50X: AC Input: 380/400/415VAC, 3 $\phi$ +N+PE, 50Hz/60HZ 72Amax Batt. Input: $\pm$ 240VDC, 100Amax
Output Rating	:	PM40X: 380/400/415VAC, 3 $\phi$ +N+PE, 50Hz/60HZ 40KVA/36KW  PM50X: 380/400/415VAC, 3 $\phi$ +N+PE, 50Hz/60HZ 50KVA/45KW
Test Voltage	:	AC 380V/50Hz
Applicant	:	INVT POWER SYSTEM (SHENZHEN) CO., LTD.
Address	:	5th Floor,1#Building,Gaofa Industrial Park, LongJing, Nanshan District, Shenzhen,China, 518055
Manufacturer	:	INVT POWER SYSTEM (SHENZHEN) CO., LTD.
Address	:	5th Floor,1#Building,Gaofa Industrial Park, LongJing, Nanshan District, Shenzhen,China, 518055
Date of Received	:	August 03, 2016
Date of Test	:	August 03, 2016 to August 23, 2016

## 2.2. Description of Support Device

N/A :

## 2.3. Description of Test Facility

### Site Description

EMC Lab. : Accredited by CNAS, 2013.10.29  
The certificate is valid until 2016.10.28  
The Laboratory has been assessed and proved to be in compliance with CNAS-CL01: 2006 (identical to ISO/IEC17025: 2005)  
The Certificate Registration Number is L2291.

Accredited by TUV Rheinland Guangzhou 2010.5.25  
The Laboratory has been assessed according to the requirements ISO/IEC 17025

Accredited by FCC, Valid until 2017/07/12  
The Certificate Registration Number is 406365.

Accredited by Industry Canada, November 24, 2015  
The Certificate Registration Number. is 4480A

Name of Firm : EMTEK (SHENZHEN) CO., LTD.  
Site Location : Bldg 69, Majialong Industry Zone,  
Nanshan District, Shenzhen, Guangdong, China

## 2.4. Measurement Uncertainty

Test Item	Uncertainty
Conducted Emission Uncertainty	: 3.16dB(9k~150kHz Conduction 2#) 2.90dB(150k-30MHz Conduction 2#)
Radiated Emission Uncertainty (10m Chamber)	: 4.0dB (30M~1GHz Polarize: H) 4.2dB (30M~1GHz Polarize: V)
Uncertainty for C/S Test	: 1.45(Using CDN Test) 2.37(Using EM Clamp Test)
Uncertainty for R/S Test	: 2.10dB(80MHz-200MHz) 1.76dB(200MHz-1000MHz)
Uncertainty for test site temperature and humidity	: 0.6°C : 4%



### 3. MEASURING DEVICE AND TEST EQUIPMENT

#### 3.1. For Conducted Emission Measurement

Used	Equipment	Manufacturer	Model No.	Serial No.	Last Cal.	Cal. Interval
<input checked="" type="checkbox"/>	Test Receiver	Rohde & Schwarz	ESCI	26115-010-0027	May 28, 2016	1 Year
<input checked="" type="checkbox"/>	L.I.S.N.	Rohde & Schwarz	ENV216	101161	May 28, 2016	1 Year
<input checked="" type="checkbox"/>	50Ω Coaxial Switch	Anritsu	MP59B	6100175589	May 29, 2016	1 Year
<input checked="" type="checkbox"/>	Voltage Probe	Rohde & Schwarz	ESH2-Z3	100122	May 29, 2016	1 Year

#### 3.2. For Radiated Emission Measurement

Used	Equipment	Manufacturer	Model No.	Serial No.	Last Cal.	Cal. Interval
<input checked="" type="checkbox"/>	EMI Test Receiver	Rohde & Schwarz	ESR3	1316.3003K03-101706-HN	May 29, 2016	1 Year
<input checked="" type="checkbox"/>	EMI Test Receiver	Rohde & Schwarz	ESR3	1316.3003K03-101707-Z1	May 29, 2016	1 Year
<input checked="" type="checkbox"/>	Pre-Amplifier	Lunar EM	LNA10M1G-40	J1011130912001	May 28, 2016	1 Year
<input checked="" type="checkbox"/>	Pre-Amplifier	Lunar EM	LNA10M1G-40	J1011131126002	May 28, 2016	1 Year
<input checked="" type="checkbox"/>	Bilog Antenna	Schwarzbeck	VULB9163	659	May 28, 2016	1 Year
<input checked="" type="checkbox"/>	Bilog Antenna	Schwarzbeck	VULB9163	661	May 29, 2016	1 Year
<input checked="" type="checkbox"/>	Cable	Times Microwave	LMR-240 N-N 1m	SS26-P1	May 29, 2016	1 Year
<input checked="" type="checkbox"/>	Cable	Times Microwave	LMR-240 N-N 1m	SS26-P2	May 29, 2016	1 Year
<input checked="" type="checkbox"/>	Cable	Times Microwave	LMR-240 N-N 1.5m	N/A	May 29, 2016	1 Year
<input checked="" type="checkbox"/>	Cable	Times Microwave	LMR-240 N-N 1.5m	N/A	May 29, 2016	1 Year
<input checked="" type="checkbox"/>	Cable	Times Microwave	LMR-240 N-N 12m	N/A	May 29, 2016	1 Year
<input checked="" type="checkbox"/>	Cable	Times Microwave	LMR-240 N-N 11m	N/A	May 29, 2016	1 Year

#### 3.3. For Electrostatic Discharge Immunity Test

Used	Equipment	Manufacturer	Model No.	Serial No.	Last Cal.	Cal. Interval
<input checked="" type="checkbox"/>	ESD Tester	TESEQ AG	NSG 438A	130	May 29, 2016	1 Year
<input checked="" type="checkbox"/>	Impulse Module	TESEQ AG	IN NSG 438AA 4380-150pF/33 00hm	403-550/1712	May 29, 2016	1 Year

### 3.4. For RF Strength Susceptibility Test

Used	Equipment	Manufacturer	Model No.	Serial No.	Last Cal.	Cal. Interval
<input checked="" type="checkbox"/>	Signal Generator	Agilent	N5181A	MY50145187	May 28, 2016	1 Year
<input checked="" type="checkbox"/>	RF Power Meter. Dual Channel	BOONTON	4232A	10539	May 29, 2016	1 Year
<input checked="" type="checkbox"/>	50ohm Diode Power Sensor	BOONTON	51011EMC	34236/34238	May 29, 2016	1 Year
<input checked="" type="checkbox"/>	Field Strength Meter	DARE	RSS1006A	10I00037SO22	May 29, 2016	1 Year
<input checked="" type="checkbox"/>	50ohm Diode Power Sensor	BOONTON	51011EMC	36164	May 29, 2016	1 Year
<input checked="" type="checkbox"/>	Power Amplifier	MILMEGA	80RF1000-175	1059345	May 28, 2016	1 Year
<input type="checkbox"/>	Power Amplifier	MILMEGA	AS0102-55	1018770	May 28, 2016	1 Year
<input checked="" type="checkbox"/>	Power Amplifier	MILMEGA	AS1860-50	1059346	May 28, 2016	1 Year
<input checked="" type="checkbox"/>	Log.-Per. Antenna	SCHWARZBECK	VULP 9118E	811	May 29, 2016	1 Year
<input type="checkbox"/>	Broad-Band Horn Antenna	SCHWARZBECK	STLP 9149	9149-227	May 29, 2016	1 Year
<input checked="" type="checkbox"/>	Multi-function interface system	DARE	CTR1009B	12I00250SNO72	N/A	N/A
<input checked="" type="checkbox"/>	Automatic switch group	DARE	RSW1004A	N/A	N/A	N/A

### 3.5. For Electrical Fast Transient /Burst Immunity Test

Used	Equipment	Manufacturer	Model No.	Serial No.	Last Cal.	Cal. Interval
<input checked="" type="checkbox"/>	Burst Tester	HAEFELY	PEFT4010	080981-16	May 29, 2016	1Year
<input type="checkbox"/>	Coupling Clamp	HAEFELY	IP-4A	147147	May 29, 2016	1Year

### 3.6. For Surge Immunity Test

Used	Equipment	Manufacturer	Model No.	Serial No.	Last Cal.	Cal. Interval
<input checked="" type="checkbox"/>	Surge Controller	HAEFELY	Psurge 8000	174031	May 29, 2016	1Year
<input checked="" type="checkbox"/>	Impulse Module	HAEFELY	PIM 100	174124	May 29, 2016	1Year
<input checked="" type="checkbox"/>	Coupling Decoupling Filter	HAEFELY	PCD 130	172181	May 29, 2016	1Year
<input type="checkbox"/>	Coupling Module	HAEFELY	PCD122	174354	May 29, 2016	1Year
<input type="checkbox"/>	Surge Impulse Module	HAEFELY	PIM 120	174435	May 29, 2016	1Year
<input type="checkbox"/>	Coupling Module	HAEFELY	PCD 126A	174387	May 29, 2016	1Year
<input type="checkbox"/>	Impulse Module	HAEFELY	PIM 110	174391	May 29, 2016	1Year
<input type="checkbox"/>	Impulse Module	HAEFELY	PIM 150	178707	May 29, 2016	1Year

### 3.7. For Injected Current Susceptibility Test

Used	Equipment	Manufacturer	Model No.	Serial No.	Last Cal.	Cal. Interval
<input checked="" type="checkbox"/>	Simulator	EMTEST	CWS500C	0900-12	May 29, 2016	1Year
<input checked="" type="checkbox"/>	CDN	EMTEST	CDN-M2	5100100100	May 29, 2016	1Year
<input type="checkbox"/>	CDN	EMTEST	CDN-M3	0900-11	May 29, 2016	1Year
<input type="checkbox"/>	Injection Clamp	EMTEST	F-2031-23MM	368	May 29, 2016	1Year
<input checked="" type="checkbox"/>	Attenuator	EMTEST	ATT6	0010222A	May 29, 2016	1Year

### 3.8. For Magnetic Field Immunity Test

Used	Equipment	Manufacturer	Model No.	Serial No.	Last Cal.	Cal. Interval
<input checked="" type="checkbox"/>	Magnetic Field Tester	HAEFELY	MAG100	250040.1	May 28, 2016	1Year

### 3.9. For Voltage Dips and Interruptions Test

Used	Equipment	Manufacturer	Model No.	Serial No.	Last Cal.	Cal. Interval
<input checked="" type="checkbox"/>	45KVA AC Power source	Teseq	NSG 1007-45/45K VA	1305A02873	May 28, 2016	1 Year
<input type="checkbox"/>	Signal conditioning Unit	Teseq	CCN 1000-3	1305A02873	May 28, 2016	1 Year
<input type="checkbox"/>	Three phase impedance network	Teseq/Germany	INA2197/37A	1305A02873	May 28, 2016	1 Year
<input type="checkbox"/>	Three phase impedance network	Teseq/Germany	INA 2196/75A	1305A02874	May 28, 2016	1 Year
<input checked="" type="checkbox"/>	Proflin 2100 AC Switching Unit	Teseq/Germany	NSG2200-3	A22714	May 28, 2016	1 Year

### 3.10. Low Frequency Signals Test and Power Line Unbalance Test

Used	Equipment	Manufacturer	Model No.	Serial No.	Last Cal.	Cal. Interval
<input checked="" type="checkbox"/>	Programmable AC Source	CHROMA	6530	/	May 29, 2016	1Year

## 4. CONDUCTED EMISSION MEASUREMENT

### 4.1. Block Diagram of Test Setup

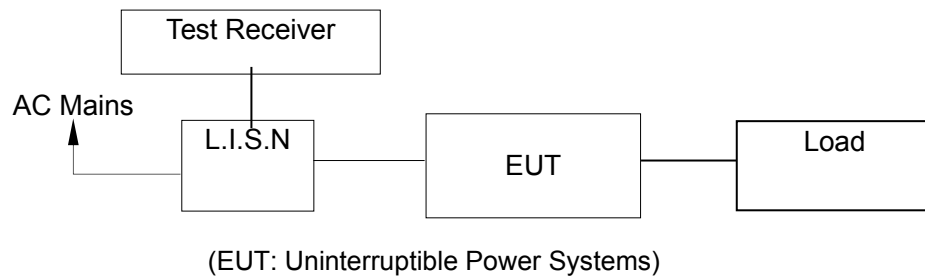

### 4.2. Measuring Standard

EN 62040-2:2006 Category C3

### 4.3. Power Line Conducted Emission Limits (C3)

UPS rated output current A	Frequency range MHz	Limits dB (μV)	
		Quasi-peak	Average
>16 – 100	0,15 to 0,50 <sup>b</sup>	100	90
	0,50 to 5,0 <sup>b</sup>	86	76
	5,0 to 30,0	90 to 70 <sup>a</sup>	80 to 60 <sup>a</sup>
>100	0,15 to 0,50 <sup>b</sup>	130	120
	0,50 to 5,0 <sup>b</sup>	125	115
	5,0 to 30,0	115	105

<sup>a</sup> The limits decrease linearly with the logarithm of the frequency.  
<sup>b</sup> The lower limit shall apply at the transition frequency.

### 4.4. EUT Configuration on Measurement

The following equipments are installed on Conducted Emission Measurement to meet EN 62040-2 requirements and operating in a manner which tends to maximize its emission characteristics in a normal application.

EUT : Uninterruptible Power Systems  
 Model Number : PM50X

#### 4.5. Operating Condition of EUT

- 4.5.1. Setup the EUT as shown on Section 4.1.
- 4.5.2. Turn on the power of all equipments.
- 4.5.3. Let the EUT work in measuring mode (Line mode, Bat mode) and measure it.

#### 4.6. Test Procedure

The EUT is put on the plane 0.1m high above the ground by insulating support and connected to the AC mains through Line Impedance Stability Network (L.I.S.N). This provided a 50ohm coupling impedance for the tested equipments. Both sides of AC line are investigated to find out the maximum conducted emission according to the EN62040-2 regulations during conducted emission measurement.

The bandwidth of the field strength meter (R&S Test Receiver ESCS30) is set at 9kHz in 150kHz~30MHz and 200Hz in 9kHz~150kHz.

The frequency range from 150kHz to 30MHz is investigated.

#### 4.7. Measuring Results

**PASS.**

All the modes are tested and the data of the worsted mode(Line mode)are attached in the following pages.

Please see the attached pages.

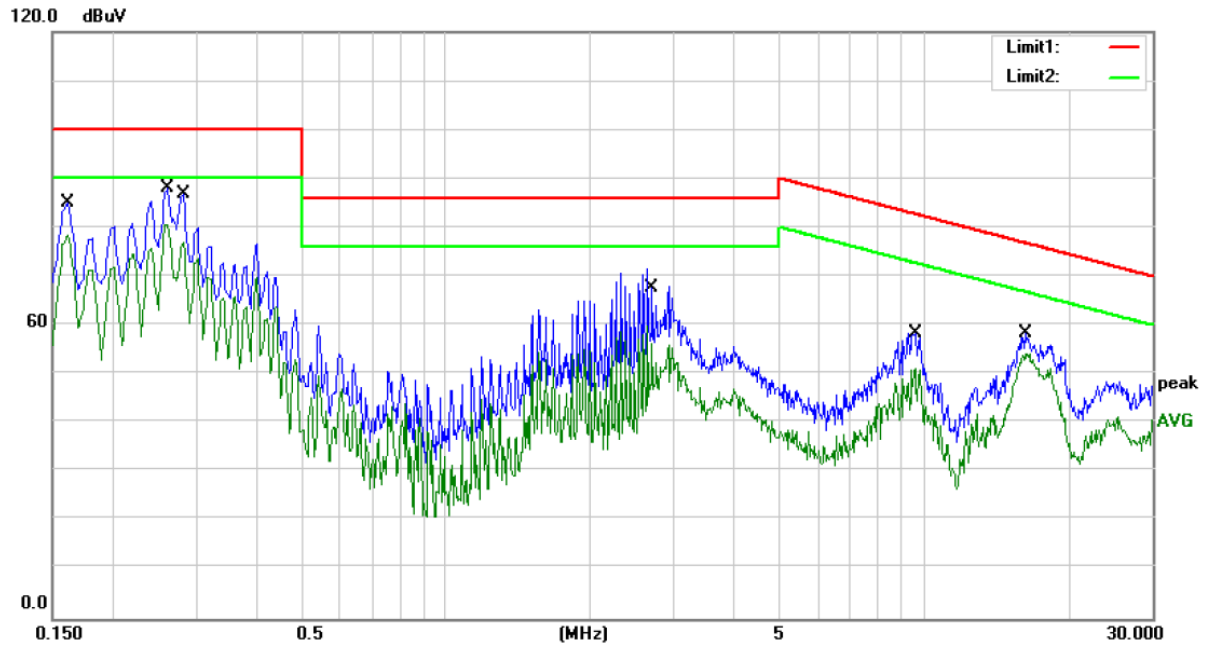

Site Conduction #2

Phase: **L1**

Temperature: 26

Limit: (CE)EN62040-2 C3\_QP

Power: AC 380V

Humidity: 55 %

Mode: LINE MODE

Note:

No.	Mk.	Freq.	Reading Level	Correct Factor	Measurement	Limit	Over	Detector	Comment
		MHz	dBuV	dB	dBuV	dBuV	dB		
1		0.1620	85.01	0.00	85.01	100.00	-14.99	QP	
2		0.1620	78.43	0.00	78.43	90.00	-11.57	AVG	
3		0.2620	87.94	0.00	87.94	100.00	-12.06	QP	
4	*	0.2620	80.65	0.00	80.65	90.00	-9.35	AVG	
5		0.2820	86.79	0.00	86.79	100.00	-13.21	QP	
6		0.2820	77.03	0.00	77.03	90.00	-12.97	AVG	
7		2.7020	67.68	0.00	67.68	86.00	-18.32	QP	
8		2.7020	55.82	0.00	55.82	76.00	-20.18	AVG	
9		9.5540	58.25	0.00	58.25	82.77	-24.52	QP	
10		9.5540	51.18	0.00	51.18	72.77	-21.59	AVG	
11		16.2820	58.37	0.00	58.37	76.82	-18.45	QP	
12		16.2820	54.21	0.00	54.21	66.82	-12.61	AVG	

\*:Maximum data    x:Over limit    !:over margin    Comment: Factor build in receiver.    Operator: HJ

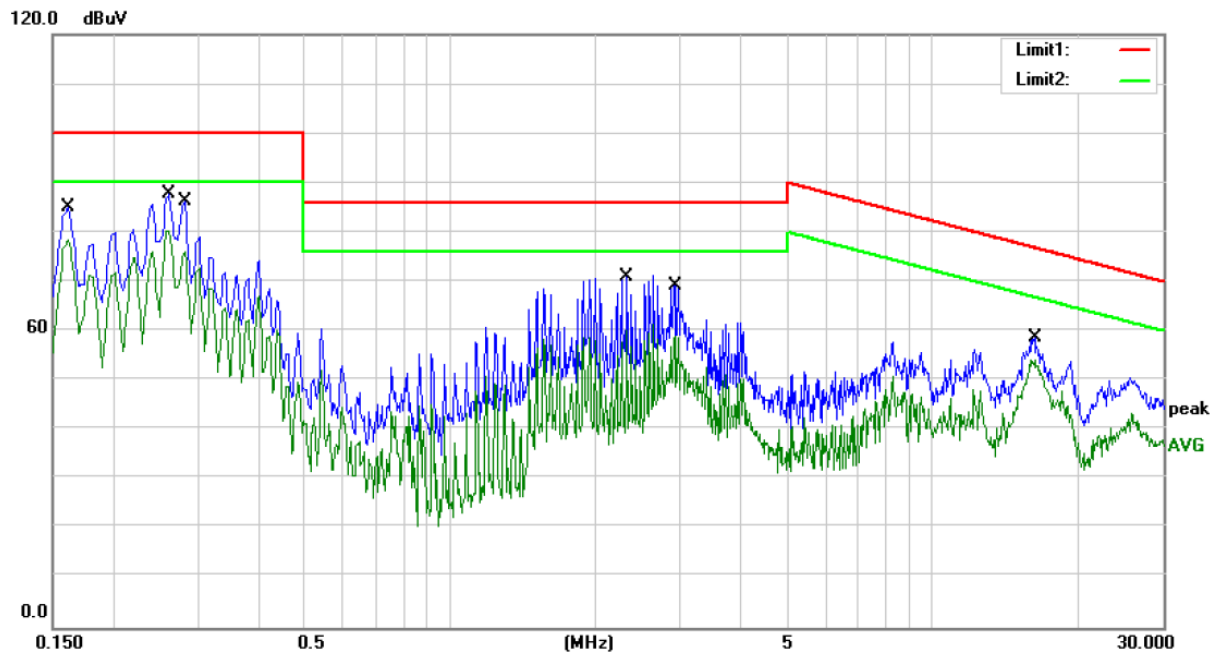

Site Conduction #2

Phase: **L2**

Temperature: 26

Limit: (CE)EN62040-2 C3\_QP

Power: AC 380V

Humidity: 55 %

Mode: LINE MODE

Note:

No.	Mk.	Freq.	Reading Level	Correct Factor	Measurement	Limit	Over	Detector	Comment
		MHz	dBuV	dB	dBuV	dBuV	dB		
1		0.1620	84.96	0.00	84.96	100.00	-15.04	QP	
2		0.1620	78.42	0.00	78.42	90.00	-11.58	AVG	
3		0.2620	87.66	0.00	87.66	100.00	-12.34	QP	
4	*	0.2620	80.24	0.00	80.24	90.00	-9.76	AVG	
5		0.2820	86.17	0.00	86.17	100.00	-13.83	QP	
6		0.2820	76.00	0.00	76.00	90.00	-14.00	AVG	
7		2.3220	71.08	0.00	71.08	86.00	-14.92	QP	
8		2.3220	60.02	0.00	60.02	76.00	-15.98	AVG	
9		2.9180	69.29	0.00	69.29	86.00	-16.71	QP	
10		2.9180	58.82	0.00	58.82	76.00	-17.18	AVG	
11		16.2820	58.71	0.00	58.71	76.82	-18.11	QP	
12		16.2820	54.08	0.00	54.08	66.82	-12.74	AVG	

\*:Maximum data    x:Over limit    !:over margin    Comment: Factor build in receiver.    Operator: HJ

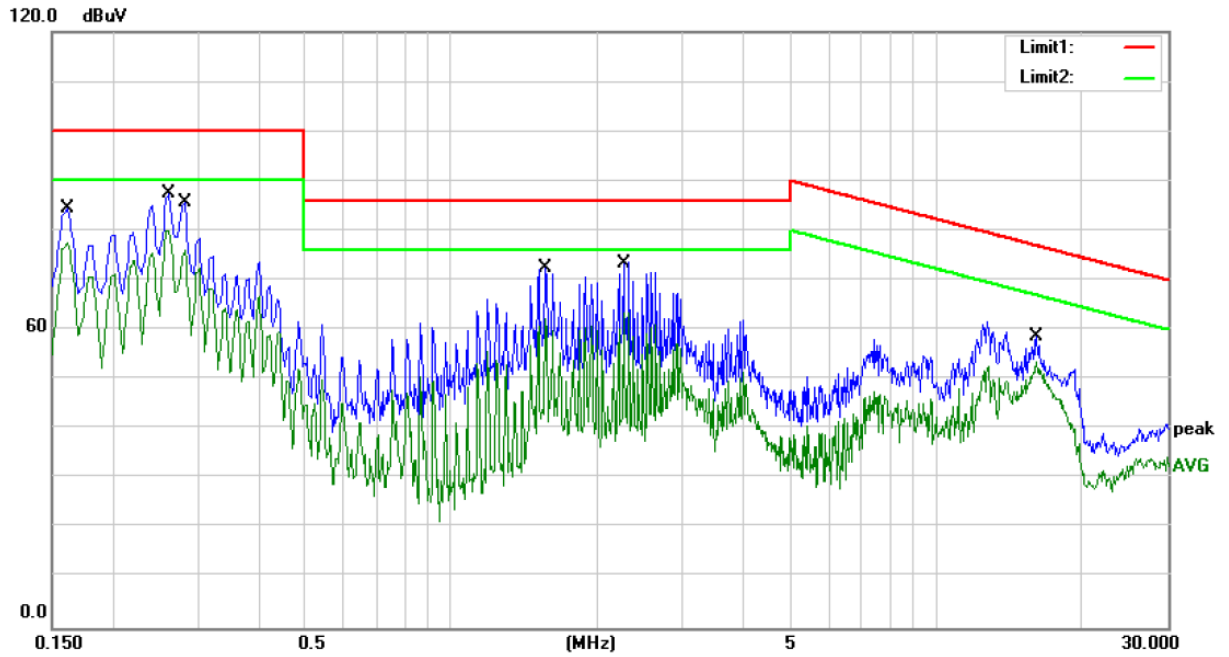

Site Conduction #2 Phase: **L3** Temperature: 26  
 Limit: (CE)EN62040-2 C3\_QP Power: AC 380V Humidity: 55 %  
 Mode: LINE MODE  
 Note:

No.	Mk.	Freq.	Reading Level	Correct Factor	Measurement	Limit	Over	Detector	Comment
		MHz	dBuV	dB	dBuV	dBuV	dB		
1		0.1620	84.52	0.00	84.52	100.00	-15.48	QP	
2		0.1620	77.64	0.00	77.64	90.00	-12.36	AVG	
3		0.2620	87.38	0.00	87.38	100.00	-12.62	QP	
4	*	0.2620	79.99	0.00	79.99	90.00	-10.01	AVG	
5		0.2820	85.68	0.00	85.68	100.00	-14.32	QP	
6		0.2820	76.01	0.00	76.01	90.00	-13.99	AVG	
7		1.5660	72.58	0.00	72.58	86.00	-13.42	QP	
8		1.5660	62.40	0.00	62.40	76.00	-13.60	AVG	
9		2.2700	73.31	0.00	73.31	86.00	-12.69	QP	
10		2.2700	63.45	0.00	63.45	76.00	-12.55	AVG	
11		16.0820	58.58	0.00	58.58	76.96	-18.38	QP	
12		16.0820	51.91	0.00	51.91	66.96	-15.05	AVG	

\*:Maximum data    x:Over limit    !:over margin    Comment: Factor build in receiver.    Operator: HJ



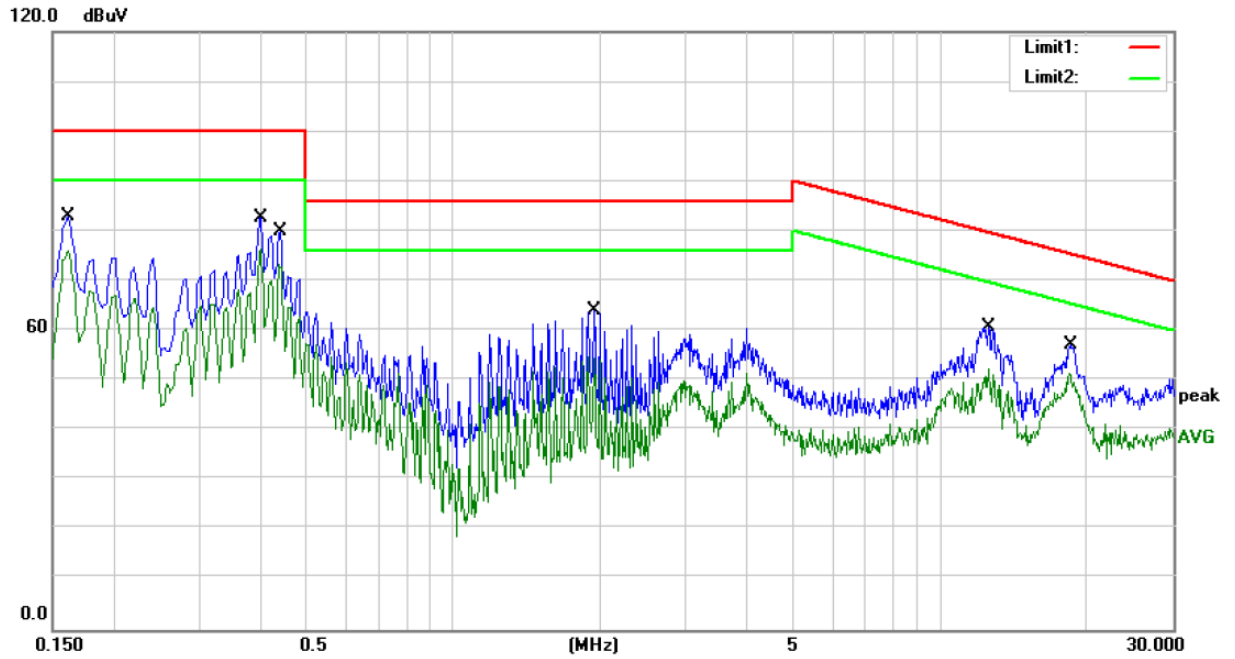

Site Conduction #2 Phase: **N** Temperature: 26  
 Limit: (CE)EN62040-2 C3\_QP Power: AC 380V Humidity: 55 %  
 Mode: LINE MODE  
 Note:

No.	Mk.	Freq.	Reading Level	Correct Factor	Measurement	Limit	Over	Detector	Comment
		MHz	dBuV	dB	dBuV	dBuV	dB		
1		0.1620	83.04	0.00	83.04	100.00	-16.96	QP	
2		0.1620	76.00	0.00	76.00	90.00	-14.00	AVG	
3		0.4020	82.68	0.00	82.68	100.00	-17.32	QP	
4	*	0.4020	76.29	0.00	76.29	90.00	-13.71	AVG	
5		0.4420	79.86	0.00	79.86	100.00	-20.14	QP	
6		0.4420	73.33	0.00	73.33	90.00	-16.67	AVG	
7		1.9460	64.14	0.00	64.14	86.00	-21.86	QP	
8		1.9460	54.63	0.00	54.63	76.00	-21.37	AVG	
9		12.5220	60.75	0.00	60.75	79.75	-19.00	QP	
10		12.5220	52.41	0.00	52.41	69.75	-17.34	AVG	
11		18.5220	57.13	0.00	57.13	75.38	-18.25	QP	
12		18.5220	51.53	0.00	51.53	65.38	-13.85	AVG	

\*:Maximum data    x:Over limit    !:over margin    Comment: Factor build in receiver.    Operator: HJ

## 5. RADIATED EMISSION MEASUREMENT

### 5.1. Block Diagram of Test Setup

#### 5.1.1. Block diagram of EUT System



(EUT: Uninterruptible Power Systems)

#### 5.1.2. Block diagram of test setup (In chamber)

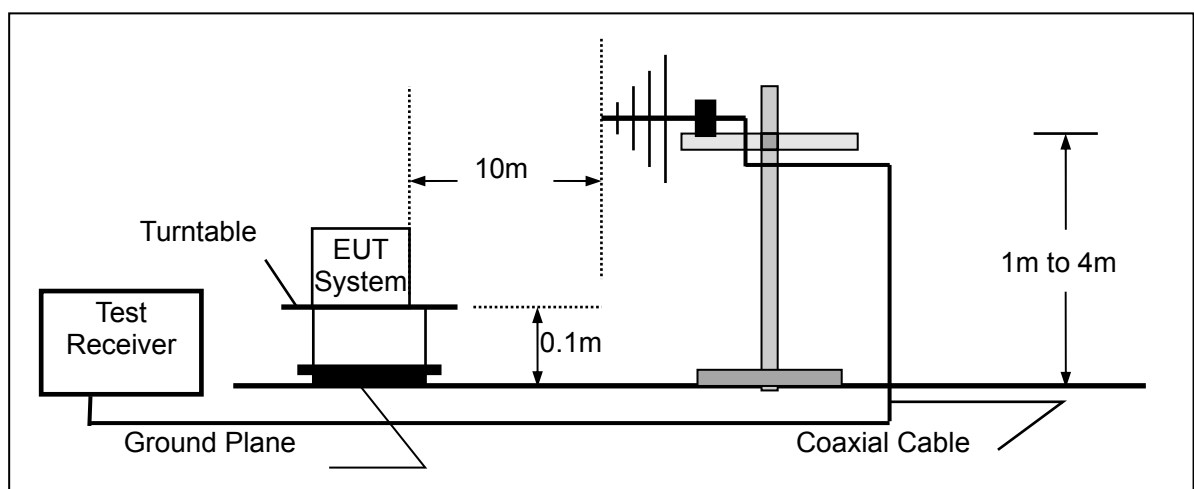

(EUT: Uninterruptible Power Systems)

### 5.2. Measuring Standard

EN 62040-2:2006 Category C3

### 5.3. Radiated Emission Limits (C3)

All emanations from a C3 device or system, including any network of conductors and apparatus connected thereto, shall not exceed the level of field strengths specified below:

FREQUENCY (MHz)	DISTANCE (Meters)	FIELD STRENGTHS LIMIT (dB $\mu$ V/m)
30 ~ 230	10	50
230 ~ 1000	10	60

- Note:
- (1) The smaller limit shall apply at the combination point between two frequency bands.
  - (2) Distance refers to the distance in meters between the measuring instrument antenna and the closed point of any part of the EUT.

#### 5.4. EUT Configuration on Measurement

The EN 62040-2 regulations test method must be used to find the maximum emission during radiated emission measurement.

EUT : Uninterruptible Power Systems  
Model Number : PM50X

#### 5.5. Operating Condition of EUT

5.5.1. Setup the EUT as shown on Section 5.1.

5.5.2. Turn on the power of all equipments.

5.5.3. Let the EUT work in measuring mode (Line mode, Bat mode) and measure it.

#### 5.6. Test Procedure

The EUT is placed on a turn table which is 0.1 meter high above the ground. The turn table can rotate 360 degrees to determine the position of the maximum emission level. The EUT is set 10 meters away from the receiving antenna which is mounted on an antenna tower. The antenna can be moved up and down from 1 to 4 meters to find out the maximum emission level. Bilog antenna (calibrated by Dipole Antenna) is used as a receiving antenna. Both horizontal and vertical polarization of the antenna are set on test.

The bandwidth of the Receiver is set at 120kHz.  
All the scanning curves in below a few pages.

#### 5.7. Measuring Results

**PASS.**

The frequency range from 30MHz to 1000MHz is investigated.

All the modes are tested and the data of the worsted mode (Line mode) are attached in the following pages.

Please see the attached pages.

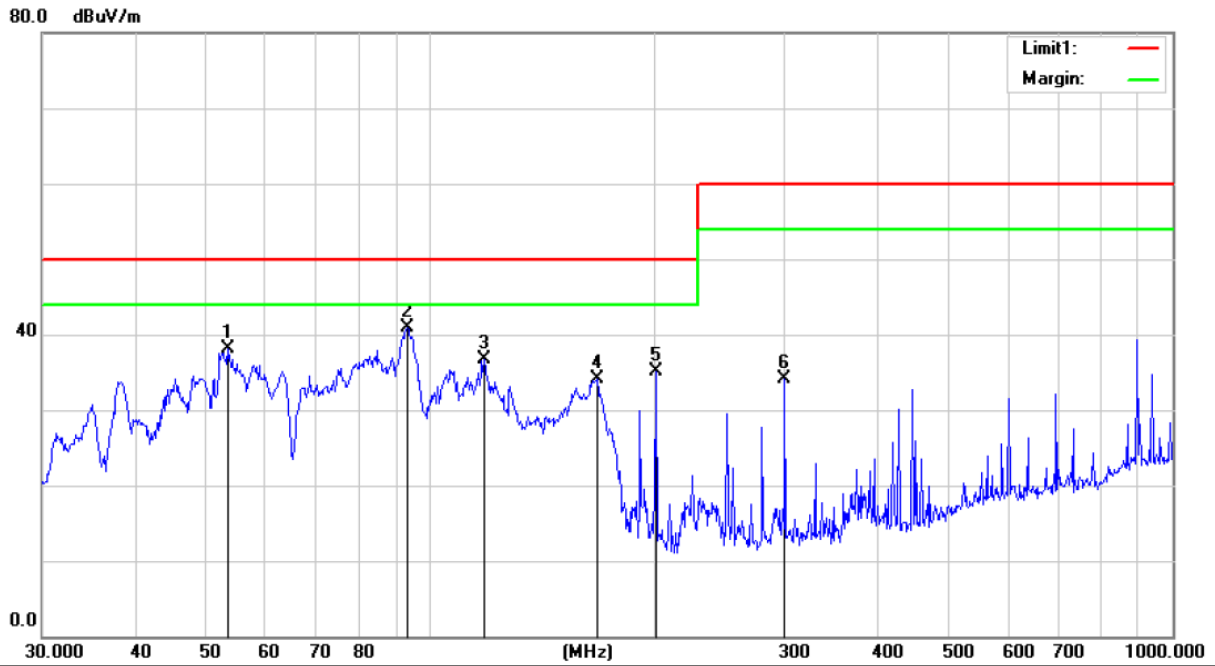

Site :10m Chamber #1      Polarization: **Horizontal**      Temperature: 26  
 Limit: (RE 10M)EN62040-2 C3      Power: AC 380V/50Hz      Humidity: 60 %  
 Mode:line MODE  
 Note:

No.	Mk.	Freq.	Reading Level	Correct Factor	Measurement	Limit	Over	Antenna Height	Table Degree	
		MHz	dBuV	dB	dBuV/m	dBuV/m	dB	cm	degree	Comment
1		53.3180	67.56	-29.47	38.09	50.00	-11.91	400	159	
2	*	93.1132	73.27	-32.30	40.97	50.00	-9.03	400	185	
3		118.1862	69.08	-32.28	36.80	50.00	-13.20	400	207	
4		167.8243	67.08	-33.01	34.07	50.00	-15.93	400	359	
5		201.3930	65.80	-30.79	35.01	50.00	-14.99	400	317	
6		300.3672	60.90	-26.84	34.06	60.00	-25.94	400	317	

\*:Maximum data    x:Over limit    !:over margin

Operator: CSL

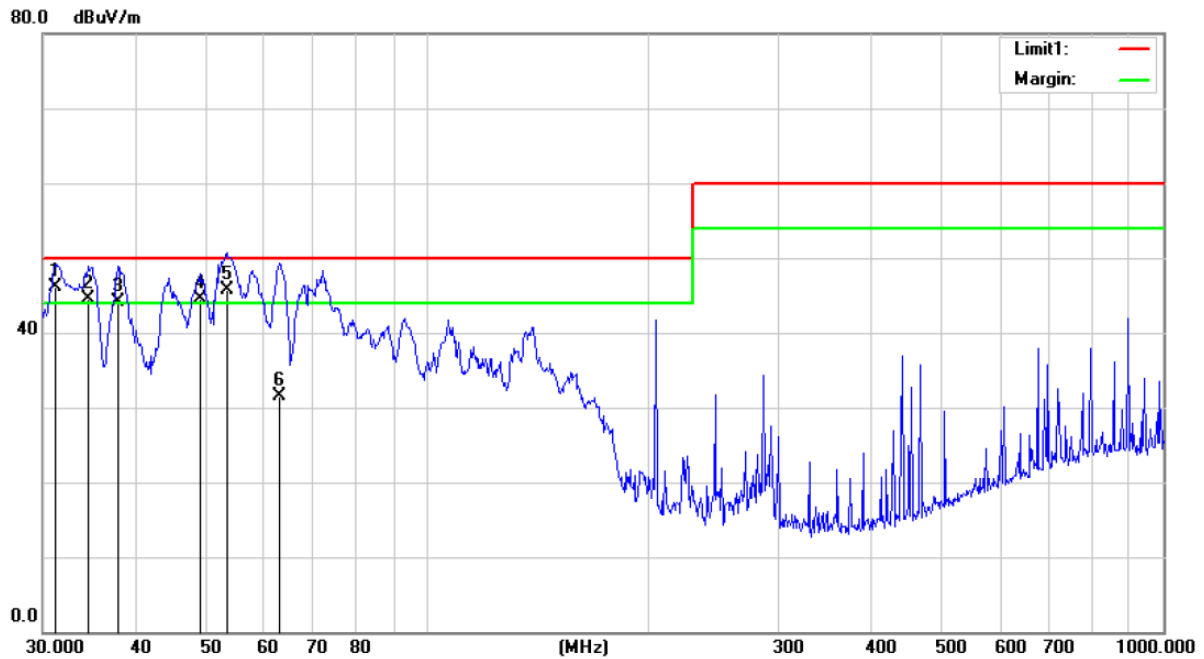

Site :10m Chamber #1

Polarization: **Vertical**

Temperature: 26

Limit: (RE 10M)EN62040-2 C3

Power: AC 380V/50Hz

Humidity: 60 %

Mode:line MODE

Note:

No.	Mk.	Freq.	Reading Level	Correct Factor	Measurement	Limit	Over	Antenna Height	Table Degree	
		MHz	dBuV	dB	dBuV/m	dBuV/m	dB	cm	degree	Comment
1	*	31.1798	77.60	-31.50	46.10	50.00	-3.90	100	133	
2	!	34.6385	75.44	-30.84	44.60	50.00	-5.40	100	153	
3	!	37.9450	74.39	-30.19	44.20	50.00	-5.80	100	79	
4	!	49.0144	73.36	-28.86	44.50	50.00	-5.50			
5	!	53.3180	74.76	-29.06	45.70	50.00	-4.30	100	222	
6		62.8708	62.04	-30.54	31.50	50.00	-18.50	100	157	

\*:Maximum data    x:Over limit    !:over margin

Operator: CSL

## 6. IMMUNITY PERFORMANCE CRITERIA DESCRIPTION

### Performance Level

The test results shall be classified in terms of the loss of function or degradation of performance of the equipment under test, relative to a performance level by its manufacturer or the requestor of the test, or the agreed between the manufacturer and the purchaser of the product.

Definition related to the performance level:

1. Based on the used product standard
2. Based on the declaration of the manufacturer, requestor or purchaser

Criterion A:

Definition: normal performance within limits specified by the manufacturer, requestor and purchaser.

The equipment shall continue to operate as intended without operator intervention. No degradation of performance or loss of function is allowed below a performance level specified by the manufacturer when the equipment is used as intended. The performance level may be replaced by a permissible loss of performance. If the minimum performance level or the permissible performance loss is not specified by the manufacturer, then either of these may be derived from the product description and documentation, and by what the user may reasonably expect from the equipment if used as intended.

Criterion B:

Definition: temporary loss of function or degradation of performance which ceases after the disturbance ceases, and from which the equipment under test recovers its normal performance, without operator intervention.

After the test, the EUT shall continue to operate as intended without operator intervention. No degradation of performance or loss of function is allowed, after the application of the phenomena below a performance level specified by the manufacturer, when the EUT is used as intended. The performance level may be replaced by a permissible loss of performance. During the test, degradation of performance is allowed. However, no change of operating state or stored data is allowed to persist after the test. If the minimum performance level (or the permissible performance loss) is not specified by the manufacturer, then either of these may be derived from the product description and documentation, and by what the user may reasonably expect from the EUT if used as intended.

Criterion C:

Definition: temporary loss of function or degradation of performance, the correction of which requires operator intervention.

Loss of function is allowed, provided the function is self-recoverable, or can be restored by the operation of the controls by the user in accordance with the manufacturer's instructions. Functions, and/or information stored in non-volatile memory, or protected by a battery backup, shall not be lost.

Criterion D

Definition: loss of function or degradation of performance, which is not recoverable, owing to damage to hardware or software, or loss of data.

## 7. ELECTROSTATIC DISCHARGE IMMUNITY TEST

### 7.1. Block Diagram of Test Setup

#### 7.1.1. Block diagram of connection between the EUT and simulators



(EUT: Uninterruptible Power Supply)

#### 7.1.2. Block diagram of ESD test setup

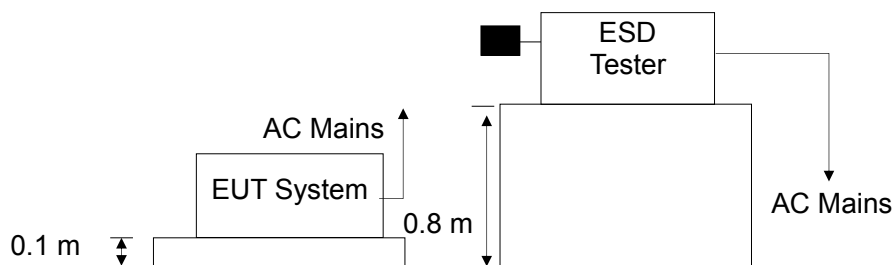

(EUT: Uninterruptible Power Supply)

### 7.2. Test Standard

EN 62040-2:2006, IEC 61000-4-2:2008 (Air Discharge:  $\pm 8\text{kV}$ , Contact Discharge:  $\pm 4\text{kV}$ )

### 7.3. Severity Levels and Performance Criterion

#### 7.3.1. Severity level

Level	Test Voltage Contact Discharge (kV)	Test Voltage Air Discharge (kV)
1	$\pm 2$	$\pm 2$
2	$\pm 4$	$\pm 4$
3	$\pm 6$	$\pm 8$
4	$\pm 8$	$\pm 15$
X	Special	Special

#### 7.3.2. Performance criterion: B



## 7.4. Operating Condition of EUT

7.4.1. Setup the EUT as shown on Section 7.1.

7.4.2. Turn on the power of all equipments.

7.4.3. Let the EUT work in test mode (Line mode, Bat mode) and test it.

## 7.5. Test Procedure

### 7.5.1. Air Discharge:

This test is done on a non-conductive surface. The round discharge tip of the discharge electrode shall be approached as fast as possible to touch the EUT. After each discharge, the discharge electrode shall be removed from the EUT. The generator is then re-triggered for a new single discharge and repeated 10 times for each pre-selected test point. This procedure shall be repeated until all the air discharge completed.

### 7.5.2. Contact Discharge:

All the procedure shall be same as Section 7.5.1. Except that the tip of the discharge electrode shall touch the EUT before the discharge switch is operated.

### 7.5.3. Indirect discharge for horizontal coupling plane

At least 10 single discharges (in the most sensitive polarity) shall be applied at the front edge of each HCP opposite the center point of each unit (if applicable) of the EUT and 0.1m from the front of the EUT. The long axis of the discharge electrode shall be in the plane of the HCP and perpendicular to its front edge during the discharge.

### 7.5.4. Indirect discharge for vertical coupling plane

At least 10 singles discharge (in the most sensitive polarity) shall be applied to the center of one vertical edge of the coupling plane. The coupling plane, of dimensions 0.5m X 0.5m, is placed parallel to, and positioned at a distance of 0.1m from the EUT. Discharges shall be applied to the coupling plane, with this plane in sufficient different positions that the four faces of the EUT are completely illuminated.

## 7.6. Test Results

**PASS.**

Please refer to the following pages.

## Electrostatic Discharge Test Result

EMTEK (SHENZHEN) CO., LTD.

Applicant	: INVT POWER SYSTEM (SHENZHEN) CO., LTD.	Test Date	: August 22, 2016
EUT	: Uninterruptible Power Supply	Temperature	: 22°C
M/N	: PM50X	Humidity	: 50%
Power Supply	: AC 380V/50Hz	Criterion	: B
Test Mode	: Line mode/Bat mode	Air discharge	: ±8.0kV
Test Engineer	: ZCJ	Contact discharge:	: ±4.0kV
Location	Kind A-Air Discharge C-Contact Discharge	Result	
Slot	A	A	
Screw	C	A	
Metal	C	A	
Screen	C	A	
HCP of all sides	C	A	
VCP of front	C	A	
VCP of rear	C	A	
VCP of left	C	A	
VCP of right	C	A	

## 8. RF FIELD STRENGTH SUSCEPTIBILITY TEST

### 8.1. Block Diagram of Test Setup

#### 8.1.1. Block diagram of connection between the EUT and Load



(EUT: Uninterruptible Power Supply)

#### 8.1.2. Block diagram of RS test setup

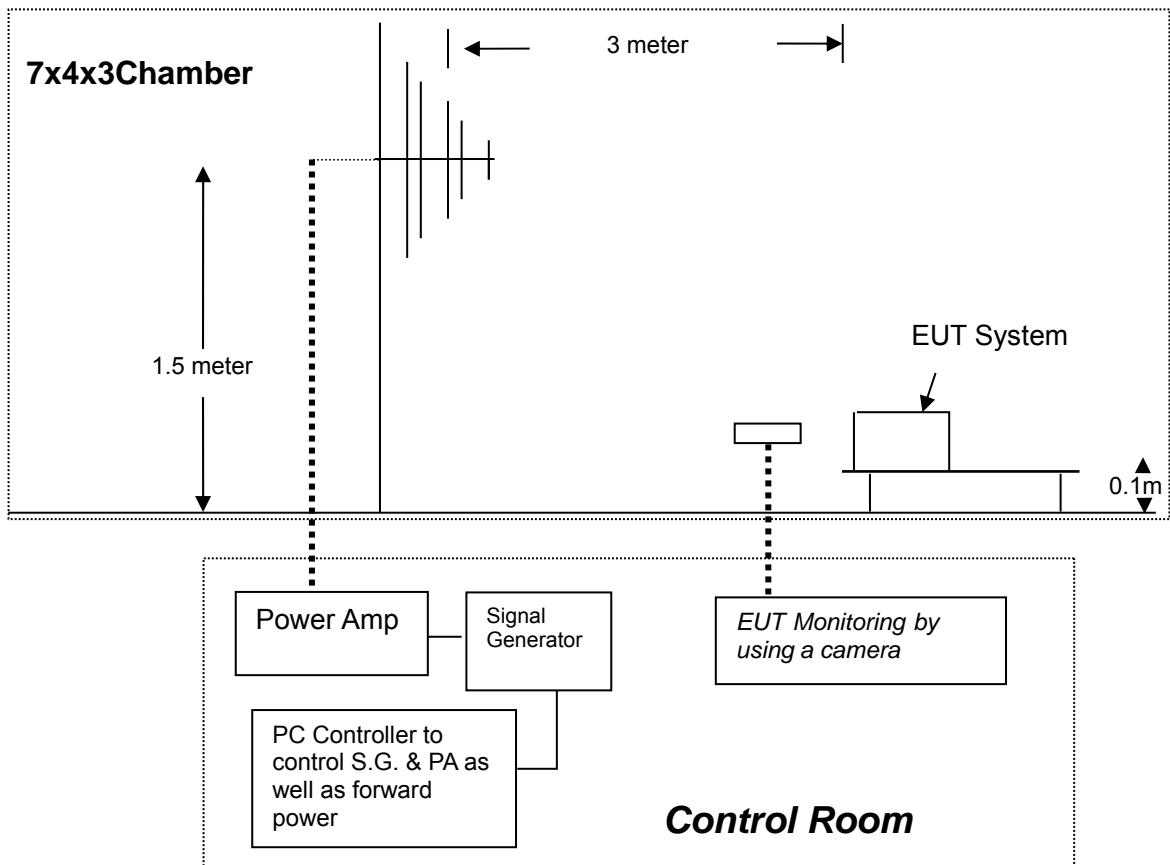

(EUT: Uninterruptible Power Supply)

### 8.2. Test Standard

EN 62040-2:2006, IEC 61000-4-3:2006+A1:2007+A2:2010 (Level 3: 10V/m)

### 8.3. Severity Levels and Performance Criterion

#### 8.3.1. Severity Levels

Level	Field Strength V/m
1.	1
2.	3
3.	10
X	Special

#### 8.3.2. Performance Criterion: A

### 8.4. Operating Condition of EUT

8.4.1. Setup the EUT as shown on Section 8.1.

8.4.2. Turn on the power of all equipments.

8.4.3. Let the EUT work in test mode (Line mode, Bat mode) and test it.

### 8.5. Test Procedure

The EUT are placed on a table that is 0.1 meter high above the ground. The EUT is set 3 meters away from the transmitting antenna that is mounted on an antenna tower. Both horizontal and vertical polarization of the antenna is set on test. Each of the four sides of the EUT must be faced this transmitting antenna and measured individually.

In order to judge the EUT performance, a CCD camera is used to monitor it.

All the scanning conditions are as following:

Condition of Test	Remark
1. Fielded Strength	10V/m (Severity Level 3)
2. Radiated Signal	Modulated
3. Scanning Frequency	80-1000MHz
4. Sweep time of radiated	0.0015 Decade/s
5. Dwell Time	1 Sec.

### 8.6. Test Results

**PASS.**

Please refer to the following page.

## RF Field Strength Susceptibility Test Results

EMTEK (SHENZHEN) CO., LTD.

<p>Applicant : INVT POWER SYSTEM (SHENZHEN) CO., LTD.</p> <hr/> <p>EUT : Uninterruptible Power Supply</p> <hr/> <p>M/N : PM50X</p> <hr/> <p>Field Strength : 10V/m</p> <hr/> <p>Power Supply : AC 380V/50Hz</p> <hr/> <p>Test Engineer : ZCJ</p> <hr/>	<p>Test Mode: Line mode/Bat mode</p> <hr/> <p>Temperature: 22°C</p> <hr/> <p>Humidity : 50%</p> <hr/> <p>Criterion: A</p> <hr/> <p>Test Date August 22, 2016</p> <hr/> <p>Frequency Range: 80 to 1000 MHz</p> <hr/>			
<p>Modulation: <input type="checkbox"/>None <input type="checkbox"/>Pulse <input checked="" type="checkbox"/>AM 1kHz 80%</p>				
<p>Frequency Rang 1: 80~ 1000MHz</p>				
<p>Frequency Rang 2: N/A</p>				
	Horizontal	Vertical	Horizontal	Vertical
Front	A	A	N/A	N/A
Right	A	A	N/A	N/A
Rear	A	A	N/A	N/A
Left	A	A	N/A	N/A
<p>Test Equipment :</p> <ol style="list-style-type: none"> <li>1. Signal Generator : 2023B (AEROFLEX)</li> <li>2. Power Amplifier : AS0102-55 (MILMEGA) &amp; AP32MT215(PRANA)</li> <li>3. Log.-Per.Antenna: VULP9118E (SCHWARZBECK)</li> <li>4. Broad-Band Horn Antenna: BBHA 9120L3F (SCHWARZBECK)</li> <li>5. RF Power Meter. Dual Channel: 4232A (BOONTON)</li> <li>6. Field Strength Meter: HI-6005 (HOLADAY)</li> </ol>				

## 9. ELECTRICAL FAST TRANSIENT/BURST IMMUNITY TEST

### 9.1. Block Diagram of Test Setup

#### 9.1.1. Block Diagram of the EUT.

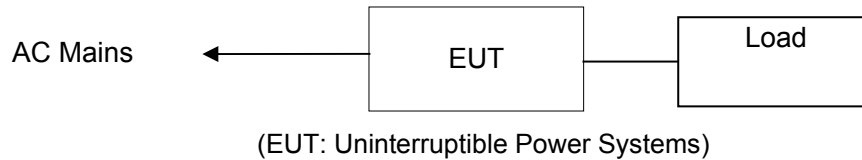

#### 9.1.2. EFT Test Setup

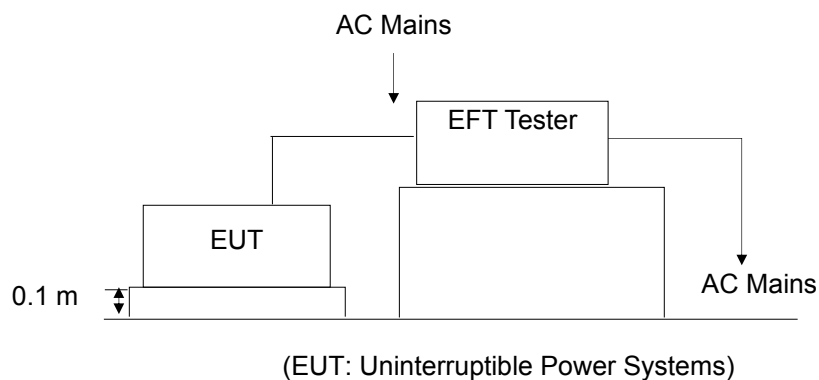

### 9.2. Test Standard

EN 62040-2:2006, EN 62040-2:2006 (IEC 61000-4-4:2012, Severity Level: 3, 2KV)

### 9.3. Severity Levels and Performance Criterion

#### 9.3.1. Severity level

Level	Open Circuit Output Test Voltage $\pm 10\%$	
	On Power Supply Lines	On I/O (Input/Output) Signal data and control lines
1	0.5 KV	0.25 KV
2	1 KV	0.5 KV
3	2 KV	1 KV
4	4 KV	2 KV
X	Special	Special

#### 9.3.2. Performance criterion: B

#### 9.4. Operating Condition of EUT

- 9.4.1. Setup the EUT as shown on Section 9.1.
- 9.4.2. Turn on the power of all equipments.
- 9.4.3. Let the EUT work in test mode (Line mode) and test it.

#### 9.5. Test Procedure

The EUT is put on the table that is 0.1 meter high above the ground. This reference ground plane shall project beyond the EUT by at least 0.1m on all sides and the minimum distance between EUT and all other conductive structure, except the ground plane beneath the EUT, shall be more than 0.5m.

##### 9.5.1..For input and output AC power ports:

The EUT is connected to the power mains by using a coupling device that couples the EFT interference signal to AC power lines. Both polarities of the test voltage should be applied during compliance test and the duration of the test is 2 mins.

##### 9.5.2..For signal lines and control lines ports:

No I/O ports. It's unnecessary to test.

##### 9.5.3..For DC output line ports:

It's unnecessary to test.

#### 9.6. Test Results

**PASS.**

Please refer to the following page.

## Electrical Fast Transient/Burst Test Results

EMTEK (SHENZHEN) CO., LTD.

Standard : <input checked="" type="checkbox"/> IEC 61000-4-4	Result: <input checked="" type="checkbox"/> PASS / <input type="checkbox"/> FAIL		
Applicant : <u>INVT POWER SYSTEM (SHENZHEN) CO., LTD</u>			
EUT : <u>Uninterruptible Power Systems</u>			
M/N : <u>PM50X</u>			
Input Voltage: <u>AC 380V / 50Hz</u>			
Criterion : B			
Ambient Condition : <u>22 °C</u> <u>50% RH</u>			
Operation Mode: Line mode			
Line : <input checked="" type="checkbox"/> AC Mains	Line : <input type="checkbox"/> Signal <input type="checkbox"/> I/O Cable		
Coupling : <input checked="" type="checkbox"/> Direct	Coupling : <input type="checkbox"/> Capacitive		
Test Time : 120s			
Line	Test Voltage	Result(+)	Result(-)
L1, L2, L3, PE	2kV	A	A
L1-L2, L1-L3, L2-L3	2kV	A	A
L1-PE, L2-PE, L3-PE,	2kV	A	A
L1-L2- PE, L1-L3- PE, L2-L3- PE, L1-L2-L3	2kV	A	A
L1-L2-L3-PE	2kV	A	A
Signal Line			
DC Line			
Note:			
Test Equipment		Burst Tester Model : PEFT 4010	



## 10. SURGE IMMUNITY TEST

### 10.1. Block Diagram of Test Setup

#### 10.1.1. Block Diagram of the EUT

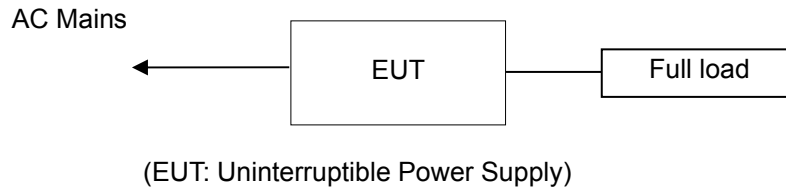

#### 10.1.2. Surge Test Setup

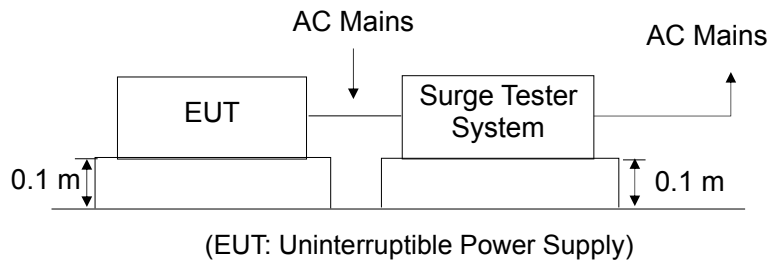

### 10.2. Test Standard

EN 62040-2:2006, IEC 61000-4-5:2014 (Line to Line: Level 2, 1.0kV, Line to earth: Level 3, 2.0kV)

### 10.3. Severity Levels and Performance Criterion

#### 10.3.1. Severity level

Severity Level	Open-Circuit Test Voltage kV
1	0.5
2	1.0
3	2.0
4	4.0
*	Special

#### 10.3.2. Performance criterion: B

### 10.4. Operating Condition of EUT

10.4.1. Setup the EUT as shown on Section 10.1.

10.4.2. Turn on the power of all equipments.

10.4.3. Let the EUT work in test mode (Line mode) and test it.

### 10.5. Test Procedure

- 1) Set up the EUT and test generator as shown on Section 10.1.2.

- 2) For line to line coupling mode, provide a 1.0 kV 1.2/50us voltage surge  
For line to earth coupling mode, provide a 2.0 kV 1.2/50us voltage surge.  
(At open-circuit condition) and 8/20us current surge to EUT selected points.
- 3) At least 5 positive and 5 negative (polarity) tests with a maximum 1/min repetition rate are conducted during test.
- 4) Different phase angles are done individually.
- 5) Record the EUT operating situation during compliance test and decide the EUT immunity criterion for above each test.

## 10.6. Test Results

**PASS.**

Please refer to the following page.

## Surge Immunity Test Results

EMTEK (SHENZHEN) CO., LTD.

Applicant : <u>INVT POWER SYSTEM (SHENZHEN) CO., LTD.</u>				Test Date : <u>August 22, 2016</u>	
EUT : <u>Uninterruptible Power Systems</u>				Temperature : <u>22°C</u>	
M/N : <u>PM50X</u>				Humidity : <u>50%</u>	
Power Supply : <u>AC 380V / 50Hz</u>				Criterion : <u>B</u>	
Test Mode : <u>Line mode</u>					
Location	Polarity	Phase Angle	Number of Pulse	Pulse Voltage (kV)	Result
L1-L2, L1-L3, L2-L3	+	0°, 90°, 180°, 270°	5	1.0	A
	-	0°, 90°, 180°, 270°	5	1.0	A
L1-N, L2-N, L3-N	+	0°, 90°, 180°, 270°	5	1.0	A
	-	0°, 90°, 180°, 270°	5	1.0	A
L1-PE, L2-PE, L3-PE	+	0°, 90°, 180°, 270°	5	2.0	A
	-	0°, 90°, 180°, 270°	5	2.0	A
N-PE	+	0°, 90°, 180°, 270°	5	2.0	A
	-	0°, 90°, 180°, 270°	5	2.0	A
Note:					

## 11. INJECTED CURRENTS SUSCEPTIBILITY TEST

### 11.1. Block Diagram of Test Setup

#### 11.1.1. Block Diagram of the EUT.

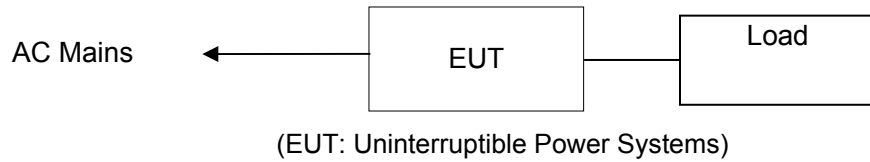

#### 11.1.2. Block Diagram of Test Setup

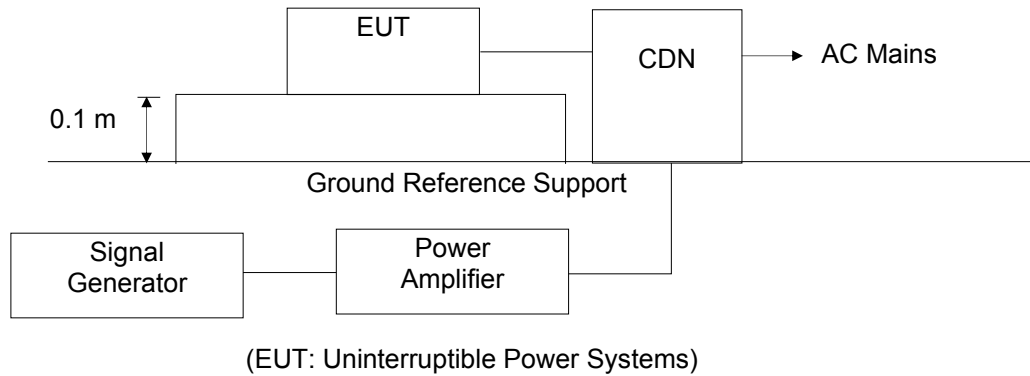

### 11.2. Test Standard

EN 62040-2:2006

(IEC 61000-4-6:2013, Severity Level: Level 3, 10V (r.m.s.), 0.15MHz ~ 80MHz)

### 11.3. Severity Levels and Performance Criterion

#### 11.3.1. Severity level

Level	Field Strength V
1	1
2	3
3	10
X	Special

#### 11.3.2. Performance criterion: A

## 11.4. Operating Condition of EUT

11.4.1. Setup the EUT as shown on Section 11.1.

11.4.2. Turn on the power of all equipments.

11.4.3. Let the EUT work in test mode (Line mode) and test it.

## 11.5. Test Procedure

- 1) Set up the EUT, CDN and test generators as shown on Section 11.1.2.
- 2) Let the EUT work in test mode and measure it.
- 3) The EUT are placed on an insulating support 0.1m high above a ground reference plane. CDN (coupling and decoupling device) is placed on the ground plane about 0.3m from EUT. Cables between CDN and EUT are as short as possible, and their height above the ground reference plane shall be between 30 and 50 mm (where possible).
- 4) The disturbance signal described below is injected to EUT through CDN.
- 5) The EUT operates within its operational mode(s) under intended climatic conditions after power on.
- 6) The frequency range is swept from 150KHz to 80MHz using 3V signal level, and with the disturbance signal 80% amplitude modulated with a 1KHz sine wave.
- 7) The rate of sweep shall not exceed  $1.5 \cdot 10^{-3}$  decades/s. where the frequency is swept incrementally; the step size shall not exceed 1% of the start and thereafter 1% of the preceding frequency value.
- 8) Recording the EUT operating situation during compliance testing and decide the EUT immunity criterion.

## 11.6. Test Results

**PASS.**

Please refer to the following page.

## Injected Currents Susceptibility Test Results

EMTEK (SHENZHEN) CO., LTD.

Applicant : <u>INVT POWER SYSTEM (SHENZHEN) CO., LTD</u>				
EUT : <u>Uninterruptible Power Systems</u>		Test Date: <u>August 22, 2016</u>		
M/N : <u>PM50X</u>		Temperature : <u>22°C</u>		
Power Supply : <u>AC 380V / 50Hz</u>		Humidity : <u>58%</u>		
Test Engineer : <u>ZCJ</u>				
Test Mode: <u>Line mode</u>				
Frequency Range (MHz)	Injected Position	Strength (Unmodulated)	Criterion	Result
0.15 ~ 80	AC Mains	10V	A	PASS
Test Mode : <u>N/A</u>				
Frequency Range (MHz)	Injected Position	Strength (Unmodulated)	Criterion	Result
Remark : 1. Modulation Signal:1KHz 80% AM Measurement Equipment : Simulator: CWS 500 (SWITZERLAND EMTEST) CDN : <input type="checkbox"/> CDN-M2 (SWITZERLAND EMTEST) <input checked="" type="checkbox"/> CDN-M3 (SWITZERLAND EMTEST)		Note:		

## 12. MAGNETIC FIELD SUSCEPTIBILITY TEST

### 12.1. Block Diagram of Test Setup

#### 12.1.1. Block diagram of test setup

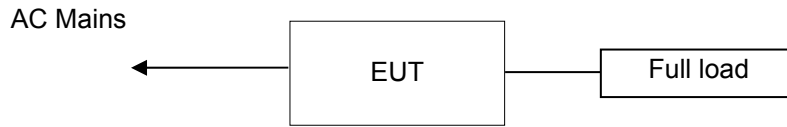

(EUT: Uninterruptible Power Supply)

#### 12.1.2. Magnetic field test setup

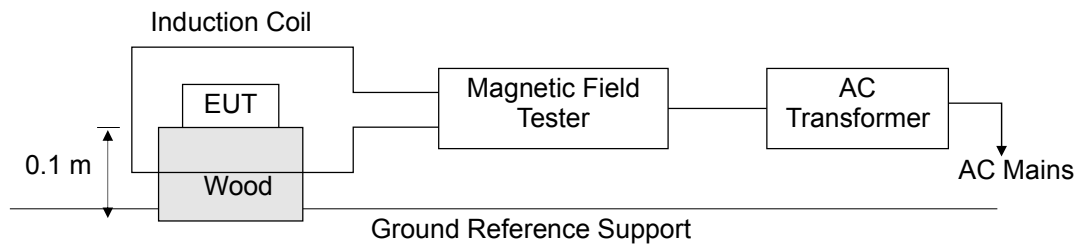

(EUT: Uninterruptible Power Supply)

### 12.2. Test Standard

EN 62040-2:2006, IEC 61000-4-8:2009 (Severity Level 4: 30A/m)

### 12.3. Severity Levels and Performance Criterion

#### 12.3.1. Severity Levels

Level	Field Strength A/m
1	1
2	3
3	10
4	30
5	100
X	Special

#### 12.3.2. Performance Criterion: A

## 12.4. Operating Condition of EUT

12.4.1. Setup the EUT as shown on Section 12.1.

12.4.2. Turn on the power of all equipments.

12.4.3. Let the EUT work in test mode (Line mode) and test it.

## 12.5. Test Procedure

The EUT is placed in the middle of an induction coil (1\*1m), under which is a 1\*1\*0.1m (high) table, this small table is also placed on a larger table, 0.1 m above the ground. Both horizontal and vertical polarization of the induction coil is set on test, so that each side of the EUT is affected by the magnetic field. Also can reach the same aim by changing the position of the EUT.

## 12.6. Test Results

**PASS.**

Please refer to the following page.



## Magnetic Field Immunity Test Result

EMTEK (SHENZHEN) CO., LTD.

Standard: <input checked="" type="checkbox"/> IEC 61000-4-8	Result: <input checked="" type="checkbox"/> PASS / <input type="checkbox"/> FAIL			
Applicant : <u>INVT POWER SYSTEM (SHENZHEN) CO., LTD.</u> EUT : <u>Uninterruptible Power Systems</u> M/N : <u>PM50X</u> Input Voltage : <u>AC 380V/50Hz</u> Date of Test : <u>August 22, 2016</u> Test Engineer: <u>ZCJ</u> Ambient Condition : Temp : <u>22°C</u> Humid: <u>50%</u> Criterion: A				
Operation Mode: Line mode				
Test Level (A/M)	Testing Duration	Coil Orientation	Criterion	Result
30	5 mins	X	A	A
30	5 mins	Y	A	A
30	5 mins	Z	A	A
Operation Mode: N/A				
Test Level (A/M)	Testing Duration	Coil Orientation	Criterion	Result
Test Equipment	Magnetic Field Test: HEAFELY MAG 100.1			
Note:				

## 13. VOLTAGE DIPS AND INTERRUPTIONS TEST

### 13.1. Block Diagram of Test Setup

#### 13.1.1. Block Diagram of the EUT.



(EUT: Uninterruptible Power Systems)

#### 13.1.2. Dips Test Setup

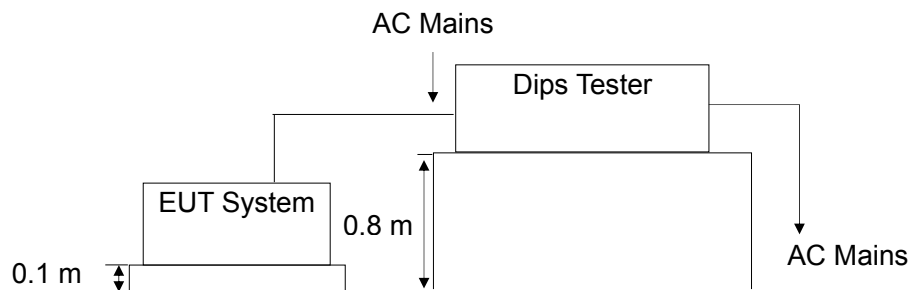

(EUT: Uninterruptible Power Systems)

### 13.2. Test Standard

EN 62040-2:2006 (IEC 61000-4-11:2004)

### 13.3. Severity Levels and Performance Criterion

#### 13.3.1. Severity level

Test Level %UT	Voltage dip and short interruptions %UT	Duration (in period)
0	100	0.5
40	60	1
		5
		10
		25
70	30	50
		*

#### 13.3.2. Performance criterion: B&C

### 13.4. Operating Condition of EUT

13.4.1. Setup the EUT as shown on Section 13.1.

13.4.2. Turn on the power of all equipments.

13.4.3. Let the EUT work in test mode (Line mode) and test it.

### 13.5. Test Procedure

- 1) Set up the EUT and test generator as shown on Section 13.1.2.
- 2) The interruption is introduced at selected phase angles with specified duration.
- 3) Record any degradation of performance.

### 13.6. Test Result

**PASS.**

Please refer to the following page.

## Voltage Dips and Interruptions Test Results

EMTEK (SHENZHEN) CO., LTD.

Applicant : <u>INVT POWER SYSTEM (SHENZHEN) CO., LTD</u>				
EUT : <u>Uninterruptible Power Systems</u>			Test Date : <u>August 22, 2016</u>	
M/N : <u>PM50X</u>			Temperature : <u>22°C</u>	
Power Supply : <u>AC 380V / 50Hz</u>			Humidity : <u>50%</u>	
Test Mode: <u>Line mode</u>				
Test Level % U <sub>T</sub>	Voltage Dips & Short Interruptions % U <sub>T</sub>	Duration (in periods)	Criterion <input checked="" type="checkbox"/> A <input type="checkbox"/> B <input type="checkbox"/> C <input type="checkbox"/> D	Result
0	100	0.5p	A	A
0	100	1 p	A	A
40	60	12 p	A	A
70	30	30 p	A	A
80	20	300 p	A	A
Test Mode : <u>N/A</u>				
Test Level % U <sub>T</sub>	Voltage Dips & Short Interruptions % U <sub>T</sub>	Duration (in periods)	Criterion <input type="checkbox"/> A <input type="checkbox"/> B <input type="checkbox"/> C <input type="checkbox"/> D	Result P=PASS F=FAIL
Note:				

## 14. LOW FREQUENCY SIGNALS TEST

### 14.1. Block Diagram of Test Setup

#### 14.1.1. Block Diagram of the EUT

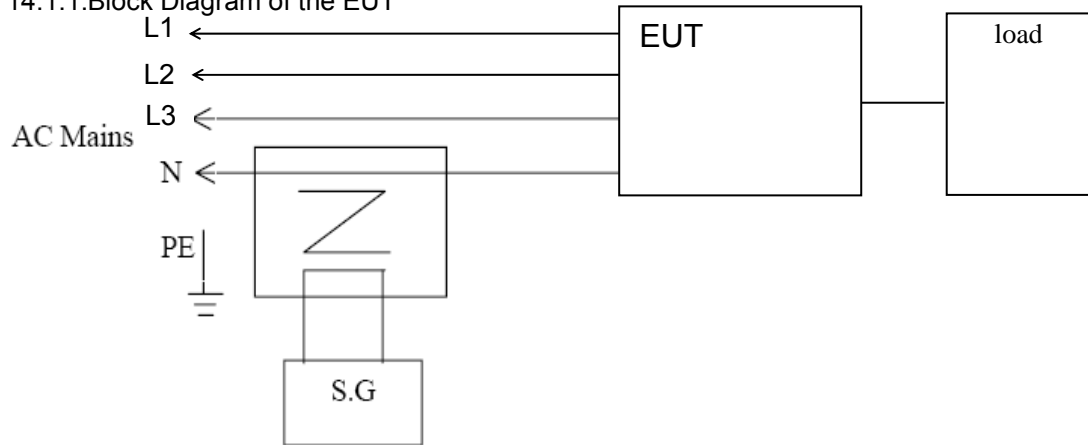

(EUT: Uninterruptible Power Systems)

### 14.2. Test Standard

EN 62040-2:2006, EN 61000-2-2: 2002, Performance: A

### 14.3. Operating Condition of EUT

14.3.1. Setup the EUT as shown on Section 14.1.

14.3.2. Turn on the power of all equipments.

14.3.3. Let the EUT work in test mode (Line mode, Bat Mode) and test it.

### 14.4. Test Results

**PASS.**

Please refer to following pages.

## Low Frequency Signals Test Result

EMTEK (SHENZHEN) CO., LTD.

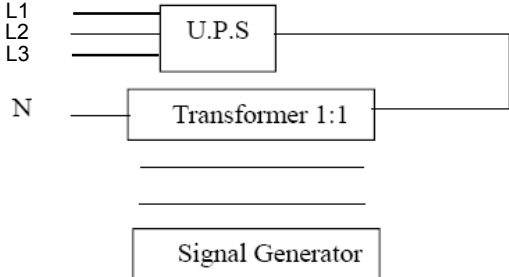
Applicant : <u>INVT POWER SYSTEM (SHENZHEN) CO., LTD</u> EUT : <u>Uninterruptible Power Systems</u> M/N : <u>PM50X</u> Power Supply : <u>AC 380V/50Hz</u> Test Engineer : <u>zcyj</u>			Test Date: <u>August 22, 2016</u> Temperature : <u>22°C</u> Humidity : <u>58%</u> Test Mode : <u>Line Mode</u>	
Frequency Range (Hz)	Position	Strength	Result	Note
140	See Fig.1	10V(rms) Sinusoidal	A	
160			A	
200			A	
240			A	
280			A	
320			A	
360			A	
<b>Note:</b> 			<b>Test Equipment:</b> 1. Isolation transformer Primary: Secondary=1:1 2. Signal Generator AC Source: 65930(Chroma)	

## 15. POWER LINE UNBALANCE (THREE-PHASE UPS SYSTEMS ONLY)

### 15.1. Block Diagram of Test Setup

#### 15.1.1. Block Diagram of the EUT

For Amplitude unbalance:

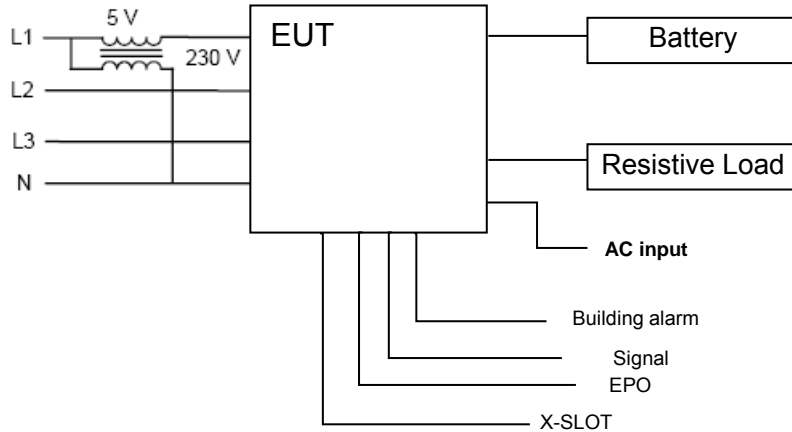

For Phase unbalance:

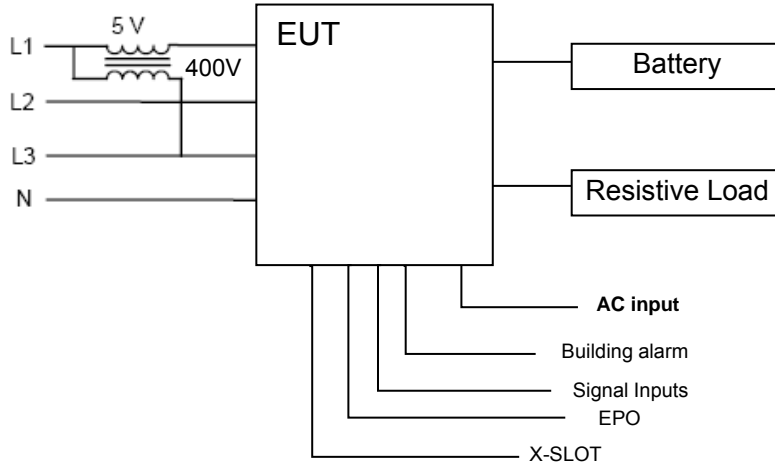

(EUT: Uninterruptible Power Systems)

### 15.2. Test Standard

EN62040-2: 2006  
Performance: A

### 15.3. Operating Condition of EUT

Same as Section 4.4, Except the test setup replaced by Section 15.1.

#### 15.4. Test Results

**PASS.**

Please refer to following page.



## Power Line Unbalance Test Result

EMTEK (SHENZHEN) CO., LTD.

Applicant : <u>INVT POWER SYSTEM (SHENZHEN) CO., LTD</u> EUT : <u>Uninterruptible Power Systems</u> M/N : <u>PM50X</u> Power Supply : <u>AC 380V/50Hz</u> Test Engineer : <u>zcj</u>			Test Date: <u>August 22, 2016</u> Temperature : <u>22°C</u> Humidity : <u>50%</u> Test Mode : <u>Line Mode</u> Actual Criterion : <u>A</u>	
Frequency Range (Hz)	Position	Strength	Result	Note
50	See 14.1.1	5V(rms) Sinusoidal	A	N/A
Note: This result for normal.  See 14.1.1			Test Equipment: 3. Isolation transformer Primary: Secondary=1:1 4. Signal Generator AC Source: 65930 (Chroma)	

## 16. TEST PHOTOGRAPH

### 16.1.Photos of Conducted Emission Measurement

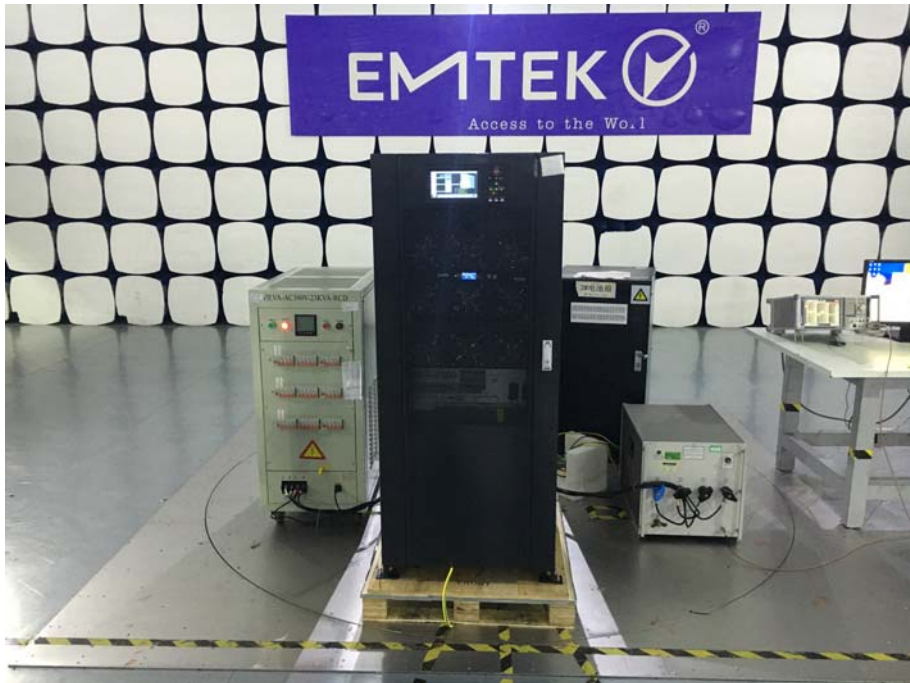

16.2. Photo of Radiation Emission Measurement



16.3. Photo of Electrostatic Discharge Test



16.4. Photo of RF Field Strength Susceptibility Test

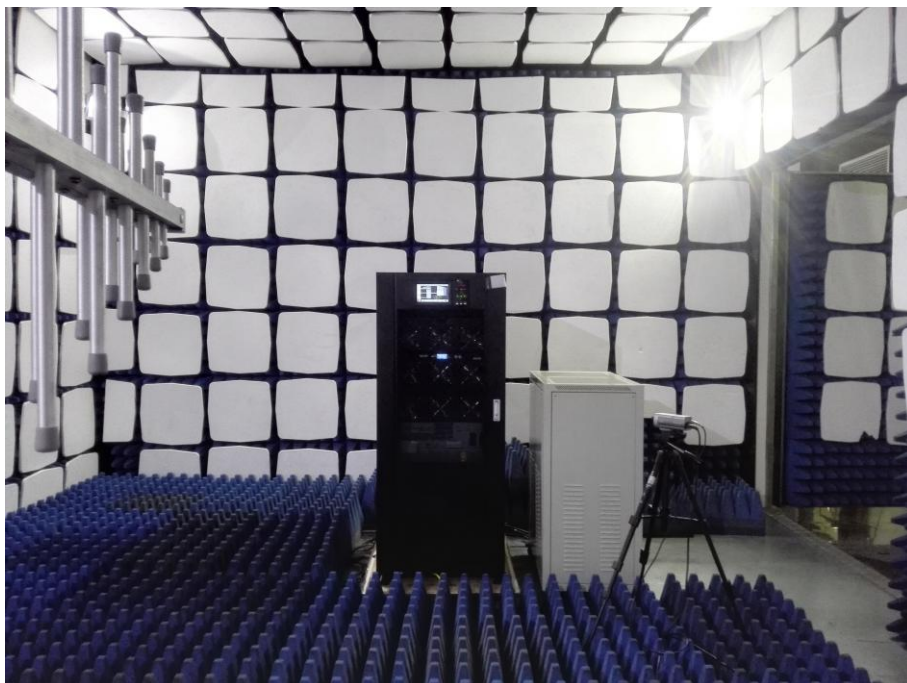



16.5.Photo of Electrical Fast Transient / Burst Test



16.6.Photo of Surge Test



16.7. Photo of Injected Currents Susceptibility Test



16.8. Photo of Magnetic Field Immunity Test



16.9.Photo of Voltage Dips and Interruptions Test



16.10.Photo of Low Frequency Signals Test and Power Line Unbalance Test



APPENDIX  
(Photos of EUT)





