

EMC TEST REPORT For

INVT POWER SYSTEM (SHENZHEN) CO., LTD.

Uninterruptible Power System

Model Number: HR1101.5L, HR1101.5S, HR1102L, HR1102S, HR1103L,
HR1103S

Prepared for : INVT POWER SYSTEM (SHENZHEN) CO., LTD.
Address : 5th Floor, 1# Building, Gaofa Industrial Park, Longjing,
Nanshan District, Shenzhen, China, 518055

Prepared by : EMTEK(SHENZHEN) CO., LTD.
Address : Bldg 69, Majialong Industry Zone,
Nanshan District, Shenzhen, Guangdong, China

Tel: (0755) 26954280
Fax: (0755) 26954282

Report Number : ES160629003E
Date of Test : January 08, 2014 to January 15, 2014
Date of Report : June 29, 2016

TABLE OF CONTENT

Description	Page
1. SUMMARY OF TEST RESULT.....	7
2. GENERAL INFORMATION.....	8
2.1. Description of Device (EUT).....	8
2.2. Description of Support Device.....	8
2.3. Description of Test Facility.....	9
2.4. Measurement Uncertainty.....	9
3. MEASURING DEVICE AND TEST EQUIPMENT.....	10
3.1. For Power Line Conducted Emission Measurement.....	10
3.2. For Radiated Emission Measurement.....	10
3.3. For Harmonic Current & Flick Measurement.....	11
3.4. For Electrostatic Discharge Immunity Test.....	11
3.5. For RF Strength Susceptibility Test.....	11
3.6. For Electrical Fast Transient / Burst Immunity Test.....	11
3.7. For Surge Immunity Test.....	12
3.8. For Injected Current Susceptibility Test.....	12
3.9. For Magnetic Field Immunity Test.....	12
3.10. For Voltage Dips and Interruptions Test.....	12
3.11. Low Frequency Signals Test.....	12
4. POWER LINE CONDUCTED EMISSION MEASUREMENT.....	13
4.1. Block Diagram of Test Setup.....	13
4.2. Measuring Standard.....	13
4.3. EUT Configuration on Measurement.....	13
4.4. Operating Condition of EUT.....	13
4.5. Test Procedure.....	13
4.6. Measuring Results.....	14
5. RADIATED EMISSION MEASUREMENT.....	19
5.1. Block Diagram of Test Setup.....	19
5.2. Measuring Standard.....	19
5.3. Radiated Emission Limits.....	19
5.4. EUT Configuration on Test.....	19
5.5. Operating Condition of EUT.....	20
5.6. Test Procedure.....	20
5.7. Measuring Results.....	20
6. HARMONIC CURRENT EMISSION MEASUREMENT.....	25
6.1. Block Diagram of Test Setup.....	25
6.2. Measuring Standard.....	25
6.3. Operation Condition of EUT.....	25
6.4. Measuring Results.....	25
7. VOLTAGE FLUCTUATION AND FLICKER MEASUREMENT.....	29
7.1. Block Diagram of Test Setup.....	29
7.2. Measuring Standard.....	29
7.3. Operation Condition of EUT.....	29
7.4. Measuring Results.....	29
8. ELECTROSTATIC DISCHARGE IMMUNITY TEST.....	31
8.1. Block Diagram of Test Setup.....	33
8.2. Test Standard.....	33
8.3. Severity Levels and Performance Criterion.....	33
8.4. EUT Configuration.....	34

8.5. Operating Condition of EUT.....	34
8.6. Test Procedure.....	34
8.7. Test Results.....	34
9. RF FIELD STRENGTH SUSCEPTIBILITY TEST.....	36
9.1. Block Diagram of Test Setup.....	36
9.2. Test Standard.....	36
9.3. Severity Levels and Performance Criterion.....	37
9.4. EUT Configuration on Test.....	37
9.5. Operating Condition of EUT.....	37
9.6. Test Procedure.....	37
9.7. Test Results.....	37
10. ELECTRICAL FAST TRANSIENT/BURST IMMUNITY TEST.....	39
10.1. Block Diagram of Test Setup.....	39
10.2. Test Standard.....	39
10.3. Severity Levels and Performance Criterion.....	39
10.4. EUT Configuration.....	40
10.5. Operating Condition of EUT.....	40
10.6. Test Procedure.....	40
10.7. Test Result.....	40
11. SURGE IMMUNITY TEST.....	42
11.1. Block Diagram of Test Setup.....	42
11.2. Test Standard.....	42
11.3. Severity Levels and Performance Criterion.....	42
11.4. EUT Configuration.....	43
11.5. Operating Condition of EUT.....	43
11.6. Test Procedure.....	43
11.7. Test Result.....	43
12. INJECTED CURRENTS SUSCEPTIBILITY TEST.....	45
12.1. Block Diagram of Test Setup.....	45
12.2. Test Standard.....	45
12.3. Severity Levels and Performance Criterion.....	45
12.4. EUT Configuration.....	46
12.5. Operating Condition of EUT.....	46
12.6. Test Procedure.....	46
12.7. Test Results.....	46
13. MAGNETIC FIELD SUSCEPTIBILITY TEST.....	48
13.1. Block Diagram of Test Setup.....	48
13.2. Test Standard.....	48
13.3. Severity Levels and Performance Criterion.....	48
13.4. EUT Configuration on Test.....	49
13.5. Test Procedure.....	49
13.6. Test Results.....	49
14. VOLTAGE DIPS AND INTERRUPTIONS TEST.....	51
14.1. Block Diagram of Test Setup.....	51
14.2. Test Standard.....	51
14.3. Severity Levels and Performance Criterion.....	51
14.4. EUT Configuration.....	52
14.5. Operating Condition of EUT.....	52
14.6. Test Procedure.....	52
14.7. Test Result.....	52
15. LOW FREQUENCY SIGNALS TEST.....	54
15.1. Block Diagram of Test Setup.....	54
15.2. Test Standard.....	54
15.3. Operating Condition of EUT.....	54
15.4. Test Results.....	54

16. TEST PHOTOGRAPHS.....	56
16.1. Photo of Conducted Emission Measurement.....	56
16.2. Photo of Radiation Emission Measurement.....	57
16.3. Photo of Harmonic / Flick Measurement.....	58
16.4. Photo of Electrostatic Discharge Test.....	58
16.5. Photo of RF Field Strength Susceptibility Test.....	59
16.6. Photo of Electrical Fast Transient / Burst Test.....	59
16.7. Photo of Surge Test.....	60
16.8. Photo of Injected Currents Susceptibility Test.....	60
16.9. Photo of Magnetic Field Immunity Test.....	61
16.10. Photo of Voltage Dips and Interruptions Test.....	61
16.11. Photo of Low Frequency Signals Test.....	62

APPENDIX (Photos of EUT) (6 Pages)

TEST REPORT DESCRIPTION

Applicant : INVT POWER SYSTEM (SHENZHEN) CO., LTD.
Manufacturer : INVT POWER SYSTEM (SHENZHEN) CO., LTD.
Trademark : INVT
EUT : Uninterruptible Power System
Model Number : HR1101.5L, HR1101.5S, HR1102L, HR1102S, HR1103L, HR1103S
Power Supply : Please refer to the page 8

Measurement Procedure Used:

EN 62040-2:2006
EN 61000-3-2:2014
EN 61000-3-3:2013
(IEC 61000-4-2:2008, IEC 61000-4-3:2006+A1:2007+A2:2010, IEC 61000-4-4:2004+A1:2010,
IEC 61000-4-5:2014, IEC 61000-4-6:2013, IEC 61000-4-8:2009, IEC 61000-4-11:2004,
EN 61000-2-2:2002)

The device described above is tested by EMTEK(SHENZHEN) CO., LTD. to determine the maximum emission levels emanating from the device and the severe levels of the device can endure and its performance criterion. The measurement results are contained in this test report and EMTEK(SHENZHEN) CO., LTD. is assumed full of responsibility for the accuracy and completeness of these measurements. Also, this report shows that the EUT (Equipment Under Test) is technically compliant with the EN 62040-2 requirements.

This report applies to above tested sample only and shall not be reproduced in part without written approval of EMTEK(SHENZHEN) CO., LTD.

Date of Test : January 08, 2014 to January 15, 2014

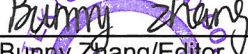
Prepared by : 
Bunny Zhang/Editor

Reviewer : 
Jessie Hu/Supervisor

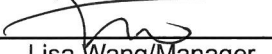
Approved & Authorized Signer : 
Lisa Wang/Manager

Modified History

Version	Report No.	Revision Date	Summary
Ver.1.0	ES130509048E	2013-05-27	Original Report
Ver.1.1	ES130509048E-1	2014-01-16	Test The Product
Ver.1.0	ES160629003E	June 29, 2016	Update EMC directive and standards

1. SUMMARY OF TEST RESULT

EMISSION			
Description of Test Item	Standard	Limits	Results
Conducted Disturbance at Mains Terminals	EN 62040-2:2006	C2	Pass
Radiated Disturbance	EN 62040-2:2006	C2	Pass
Harmonic Current Emissions	EN 61000-3-2:2014	Class A	Pass
Voltage Fluctuation and Flicker	EN 61000-3-3:2013	Section 5	Pass
IMMUNITY (C2)			
Description of Test Item	Basic Standard	Performance Criteria	Results
Electrostatic Discharge (ESD)	IEC 61000-4-2:2008	B	Pass
Radio-Frequency, Continuous Radiated Disturbance	IEC 61000-4-3:2006+A1:2007+A2:2010	A	Pass
EFT/B Immunity	IEC 61000-4-4:2012	B	Pass
Surge Immunity	IEC 61000-4-5:2014	B	Pass
Conducted RF Immunity	IEC 61000-4-6:2013	A	Pass
Power Frequency Magnetic Field	IEC 61000-4-8:2009	A	Pass
Voltage Dips, >95% Reduction	IEC 61000-4-11:2004	B	Pass
Voltage Dips, 30% Reduction			
Voltage Interruptions			
Low Frequency Signals	EN 61000-2-2:2002	A	Pass
Note: N/A is an abbreviation for Not Applicable.			

2. GENERAL INFORMATION

2.1. Description of Device (EUT)

EUT	: Uninterruptible Power System
Model Number	: HR1101.5L, HR1101.5S, HR1102L, HR1102S, HR1103L, HR1103S (Note: All models have the same constructions, circuit diagram and PCB layout except their model model no., appearance and rating. We prepare HR1103S for EMS test.)
Input Rating	: Model no.: HR1101.5L, HR1101.5S AC Input:200/208/220/230/240Vac,1φ+N+PE,13A max, 50Hz/60Hz Batt. Input:72VDC, 25A max Model no.: HR1102L, HR1102S AC Input: 200/208/220/230/240Vac,1φ+N+PE,16A max, 50Hz/60Hz Batt. Input: 72VDC, 35A max Model no.: HR1103L, HR1103S AC Input: 200/208/220/230/240Vac,1φ+N+PE, 50Hz/60Hz, 20A max, Battery. Input: 96VDC, 37A max
Output Rating	: Model no.: HR1101.5L, HR1101.5S 200/208/220/230/240VAC, 1φ+N+PE, 7A max, 50Hz/60HZ 1500VA/1350W Model no.: HR1102L, HR1102S 200/208/220/230/240VAC, 1φ+N+PE, 9A max, 50Hz/60HZ 2000VA/1800W Model no.: HR1103L, HR1103S 200/208/220/230/240VAC, 1φ+N+PE, 14A max, 50Hz/60HZ, 3000VA/2700W
^c Test Voltage	: AC 230V/50Hz
Applicant	: INVT POWER SYSTEM (SHENZHEN) CO., LTD.
Address	: 5 th Floor, 1# Building, Gaofa Industrial Park, Longjing, Nanshan District, Shenzhen, China, 518055
Manufacturer	: INVT POWER SYSTEM (SHENZHEN) CO., LTD.
Address	: 5 th Floor, 1# Building, Gaofa Industrial Park, Longjing, Nanshan District, Shenzhen, China, 518055
Factory	: INVT POWER SYSTEM (SHENZHEN) CO., LTD.
Address	: 4# Building, Gaofa Industrial Park, Longjing, Nanshan District, Shenzhen, China, 518055
Date of Received	: January 08, 2014
Date of Test	: January 08, 2014 to January 15, 2014

2.2. Description of Support Device

N/A

2.3. Description of Test Facility

Site Description

EMC Lab. : Accredited by CNAS, 2013.10.29
The certificate is valid until 2016.10.28
The Laboratory has been assessed and proved to be in compliance with CNAS-CL01:2006 (identical to ISO/IEC 17025:2005)
The Certificate Registration Number is L2291.

Accredited by TUV Rheinland Shenzhen 2010.5.25
The Laboratory has been assessed according to the requirements ISO/IEC 17025.

Accredited by FCC, April 17, 2013
The Certificate Registration Number is 709623.

Accredited by Industry Canada, November 24, 2015
The Certificate Registration Number is 4480A.

Name of Firm : EMTEK(SHENZHEN) CO., LTD.
Site Location : Bldg 69, Majialong Industry Zone,
Nanshan District, Shenzhen, Guangdong, China

2.4. Measurement Uncertainty

Test Item	Uncertainty
Conducted Emission Uncertainty	: 2.6dB
Radiated Emission Uncertainty (10m Chamber)	: 4.0dB (30M~1GHz Polarize: H) 4.2dB (30M~1GHz Polarize: V)
Uncertainty for Flicker test	: 0.07%
Uncertainty for Harmonic test	: 1.8%
Uncertainty for C/S Test	: 1.45(Using CDN Test)
Uncertainty for R/S Test	: 2.10dB(80MHz-200MHz) 1.76dB(200MHz-1000MHz)
Uncertainty for test site temperature and humidity	: 0.6°C 4%

3. MEASURING DEVICE AND TEST EQUIPMENT

3.1. For Power Line Conducted Emission Measurement

Used	Equipment	Manufacturer	Model No.	Serial No.	Last Cal.	Cal. Interval
<input checked="" type="checkbox"/>	Test Receiver	Rohde & Schwarz	ESCS30	828985/018	May 29, 2013	1 Year
<input checked="" type="checkbox"/>	L.I.S.N.	Schwarzbeck	NNLK8129	8129-203	May 29, 2013	1 Year
<input type="checkbox"/>	L.I.S.N.	ROHDE & SCHWARZ	ESH3-Z6	100011	May 29, 2013	1 Year
<input type="checkbox"/>	L.I.S.N.	ROHDE & SCHWARZ	ESH3-Z6	100253	May 29, 2013	1 Year
<input type="checkbox"/>	L.I.S.N.	ROHDE & SCHWARZ	ESH3-Z5	100191	May 29, 2013	1 Year
<input checked="" type="checkbox"/>	50Ω Coaxial Switch	Anritsu	MP59B	M20531	N/A	N/A
<input checked="" type="checkbox"/>	Pulse Limiter	Rohde & Schwarz	ESH3-Z2	100006	May 29, 2013	1 Year
<input type="checkbox"/>	Voltage Probe	Rohde & Schwarz	TK9416	N/A	May 29, 2013	1 Year

3.2. For Radiated Emission Measurement

Used	Equipment	Manufacturer	Model No.	Serial No.	Last Cal.	Cal. Interval
<input checked="" type="checkbox"/>	EMI TEST RECEIVER	R&S/DE	ESR3	1316.300K03-1017 07-Z1	Dec.14, 2013	1Year
<input checked="" type="checkbox"/>	EMI TEST RECEIVER	R&S/DE	ESCI3	1166.5950K03-101 384-Bw	Dec.14, 2013	1Year
<input checked="" type="checkbox"/>	Frequency Analyser	R&S/DE	FSV40	132.1.3008K39-100 967-AP	Dec.14, 2013	1Year
<input checked="" type="checkbox"/>	Broadband Antenna (30M-3GHz)	Schwarzbeck/D E	VULP916 3	659/660/661	Dec.14, 2013	1Year
<input type="checkbox"/>	Horn Antenna (1G-18GHz)	Schwarzbeck/D E	BBHA912 0D	1177/1178	Dec.14, 2013	1Year
<input type="checkbox"/>	Horn Antenna (15G-26.5GHz)	Schwarzbeck/D E	BBHA917 0	547	Dec.14, 2013	1Year
<input type="checkbox"/>	Horn Antenna (26.5G-40GHz)	AHS/USA	SAS-573	184/185	Dec.14, 2013	1Year
<input checked="" type="checkbox"/>	Pre-Amplifier (10M-1GHz 40dB)	Lunar EM	PM01-1-4 0	N/A	Dec.14, 2013	1Year
<input type="checkbox"/>	Pre-Amplifier (1G-18GHz 40dB)	Lunar EM	PM1-18-4 0	J101121229001	Dec.14, 2013	1Year
<input type="checkbox"/>	Pre-Amplifier (1G-18GHz 48dB)	Lunar EM	PM1-18-4 8	DS131115120D117 7	Dec.14, 2013	1Year
<input type="checkbox"/>	Pre-Amplifier(18G-26.5GHz 40dB)	Lunar EM	PM18-26- 40	J1012131010001	Dec.14, 2013	1Year
<input type="checkbox"/>	Pre-Amplifier (18G-26.5GHz 48dB)	Lunar EM	PM18-26- 48	J1013131010001	Dec.14, 2013	1Year
<input type="checkbox"/>	Pre-Amplifier(26.5G-40GHz 40dB)	Lunar EM	PM26-40- 40	J1013131028001	Dec.14, 2013	1Year

3.3. For Harmonic Current & Flick Measurement

Used	Equipment	Manufacturer	Model No.	Serial No.	Last Cal.	Cal. Interval
<input checked="" type="checkbox"/>	45KVA AC Power source	Teseq/Germany	NSG 1007-45/45KVA	1305A02873	April 25, 2013	1 Year
<input checked="" type="checkbox"/>	Signal conditioning Unit	Teseq/Germany	CCN 1000-3	1305A02873	April 25, 2013	1 Year
<input checked="" type="checkbox"/>	Three phase impedance network	Teseq/Germany	INA2197/37A	1305A02873	April 25, 2013	1 Year
<input type="checkbox"/>	Three phase impedance network	Teseq/Germany	INA 2196/75A	1305A02874	April 25, 2013	1 Year

3.4. For Electrostatic Discharge Immunity Test

Used	Equipment	Manufacturer	Model No.	Serial No.	Last Cal.	Cal. Interval
<input checked="" type="checkbox"/>	ESD Tester	TESEQ AG	NSG 438A	130	May 29, 2013	1 Year
<input checked="" type="checkbox"/>	Impulse Module	TESEQ AG	INA 4380-150pF/330Ohm	403-550/1712	May 29, 2013	1 Year

3.5. For RF Strength Susceptibility Test

Used	Equipment	Manufacturer	Model No.	Serial No.	Last Cal.	Cal. Interval
<input checked="" type="checkbox"/>	Signal Generator	Agilent	N5181A	MY5014518 7	Nov 04, 2013	1 Year
<input checked="" type="checkbox"/>	RF Power Meter. Dual Channel	BOONTON	4232A	10539	May 29, 2013	1 Year
<input checked="" type="checkbox"/>	50ohm Diode Power Sensor	BOONTON	51011EMC	34236/3423 8	May 29, 2013	1 Year
<input checked="" type="checkbox"/>	Field Strength Meter	DARE	RSS1006A	10I00037SO 22	Nov 04, 2013	1 Year
<input checked="" type="checkbox"/>	50ohm Diode Power Sensor	BOONTON	51011EMC	36164	Nov 04, 2013	1 Year
<input checked="" type="checkbox"/>	Power Amplifier	MILMEGA	80RF1000-175	1059345	May 29, 2013	1 Year
<input type="checkbox"/>	Power Amplifier	MILMEGA	AS0102-55	1018770	May 29, 2013	1 Year
<input type="checkbox"/>	Power Amplifier	MILMEGA	AS1860-50	1059346	Nov 04, 2013	1 Year
<input checked="" type="checkbox"/>	Log.-Per. Antenna	SCHWARZBE CK	VULP 9118E	N/A	May 11, 2013	1 Year
<input type="checkbox"/>	Broad-Band Horn Antenna	SCHWARZBE CK	STLP 9149	9149-227	Nov 04, 2013	1 Year
<input checked="" type="checkbox"/>	Multi-function interface system	DARE	CTR1009B	12I00250SN O72	N/A	N/A
<input checked="" type="checkbox"/>	Automatic switch group	DARE	RSW1004A	N/A	N/A	N/A

3.6. For Electrical Fast Transient / Burst Immunity Test

Used	Equipment	Manufacturer	Model No.	Serial No.	Last Cal.	Cal. Interval
<input checked="" type="checkbox"/>	Burst Tester	HAEFELY	PEFT4010	080981-16	May 29, 2013	1 Year
<input type="checkbox"/>	Coupling Clamp	HAEFELY	IP-4A	147147	May 29, 2013	1 Year

3.7. For Surge Immunity Test

Used	Equipment	Manufacturer	Model No.	Serial No.	Last Cal.	Cal. Interval
<input checked="" type="checkbox"/>	Surge Controller	HAEFELY	Psurge 8000	174031	May 29, 2013	1Year
<input checked="" type="checkbox"/>	Impulse Module	HAEFELY	PIM 100	174124	May 29, 2013	1Year
<input checked="" type="checkbox"/>	Coupling Decoupling Filter	HAEFELY	PCD 130	172181	May 29, 2013	1Year
<input type="checkbox"/>	Coupling Module	HAEFELY	PCD122	174354	May 29, 2013	1Year
<input type="checkbox"/>	Surge Impulse Module	HAEFELY	PIM 120	174435	May 29, 2013	1Year
<input type="checkbox"/>	Coupling Module	HAEFELY	PCD 126A	174387	May 29, 2013	1Year
<input type="checkbox"/>	Impulse Module	HAEFELY	PIM 110	174391	May 29, 2013	1Year

3.8. For Injected Current Susceptibility Test

Used	Equipment	Manufacturer	Model No.	Serial No.	Last Cal.	Cal. Interval
<input checked="" type="checkbox"/>	Simulator	EMTEST	CWS500C	0900-12	May 29, 2013	1 Year
<input type="checkbox"/>	CDN	EMTEST	CDN-M2	5100100100	May 29, 2013	1 Year
<input checked="" type="checkbox"/>	CDN	EMTEST	CDN-M3	0900-11	May 29, 2013	1 Year
<input type="checkbox"/>	Injection Clamp	EMTEST	F-2031-23M M	368	May 29, 2013	1 Year
<input checked="" type="checkbox"/>	Attenuator	EMTEST	ATT6	0010222A	May 29, 2013	1 Year

3.9. For Magnetic Field Immunity Test

Used	Equipment	Manufacturer	Model No.	Serial No.	Last Cal.	Cal. Interval
<input checked="" type="checkbox"/>	Magnetic Field Tester	HAEFELY	MAG100	250040.1	May 29, 2013	1 Year

3.10. For Voltage Dips and Interruptions Test

Used	Equipment	Manufacturer	Model No.	Serial No.	Last Cal.	Cal. Interval
<input checked="" type="checkbox"/>	45KVA AC Power source	Teseq/Germany	NSG 1007-45/45KVA	1305A02873	April 25, 2013	1 Year
<input type="checkbox"/>	Signal conditioning Unit	Teseq/Germany	CCN 1000-3	1305A02873	April 25, 2013	1 Year
<input type="checkbox"/>	Three phase impedance network	Teseq/Germany	INA2197/37A	1305A02873	April 25, 2013	1 Year
<input type="checkbox"/>	Three phase impedance network	Teseq/Germany	INA 2196/75A	1305A02874	April 25, 2013	1 Year
<input checked="" type="checkbox"/>	Proflin 2100 AC Switching Unit	Teseq/Germany	NSG2200-3	A22714	April 25, 2013	1 Year

3.11. Low Frequency Signals Test

Used	Equipment	Manufacturer	Model No.	Serial No.	Last Cal.	Cal. Interval
<input checked="" type="checkbox"/>	Programmable AC Source	CHROMA	6530	/	May 29, 2013	1 Year

4. POWER LINE CONDUCTED EMISSION MEASUREMENT

4.1. Block Diagram of Test Setup

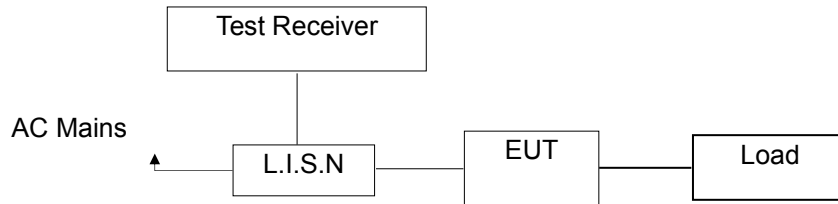

(EUT: Uninterruptible Power System)

4.2. Measuring Standard

EN 62040-2:2006 Category C2

Power Line Conducted Emission Limits:

Frequency (MHz)	Limit (dB μ V)	
	Quasi-peak Level	Average Level
0.15 ~ 0.50	79	66
0.50 ~ 30.00	73	60

4.3. EUT Configuration on Measurement

The following equipments are installed on Conducted Emission Measurement to meet EN 62040-2 requirements and operating in a manner which tends to maximize its emission characteristics in a normal application.

Uninterruptible Power System (EUT)
 Model Number : HR1103S
 Serial Number : N/A

4.4. Operating Condition of EUT

- 4.4.1. Setup the EUT as shown on Section 4.1.
- 4.4.2. Turn on the power of all equipments.
- 4.4.3. Let the EUT work in measuring mode (Line mode, Bat mode) and measure it.

4.5. Test Procedure

The EUT is put on the plane 0.8m high above the ground by insulating support and connected to the AC mains through Line Impedance Stability Network (L.I.S.N). This provided a 50ohm coupling impedance for the tested equipments. Both sides of AC line are investigated to find out the maximum conducted emission according to the EN 62040-2 regulations during conducted emission measurement.

The bandwidth of the field strength meter (R&S Test Receiver ESCS30) is set at 9kHz in 150kHz~30MHz and 200Hz in 9kHz~150kHz.

The frequency range from 150kHz to 30MHz is investigated.

All the scanning waveform is put in the following pages.

4.6. Measuring Results

PASS.

Please refer to the following pages.

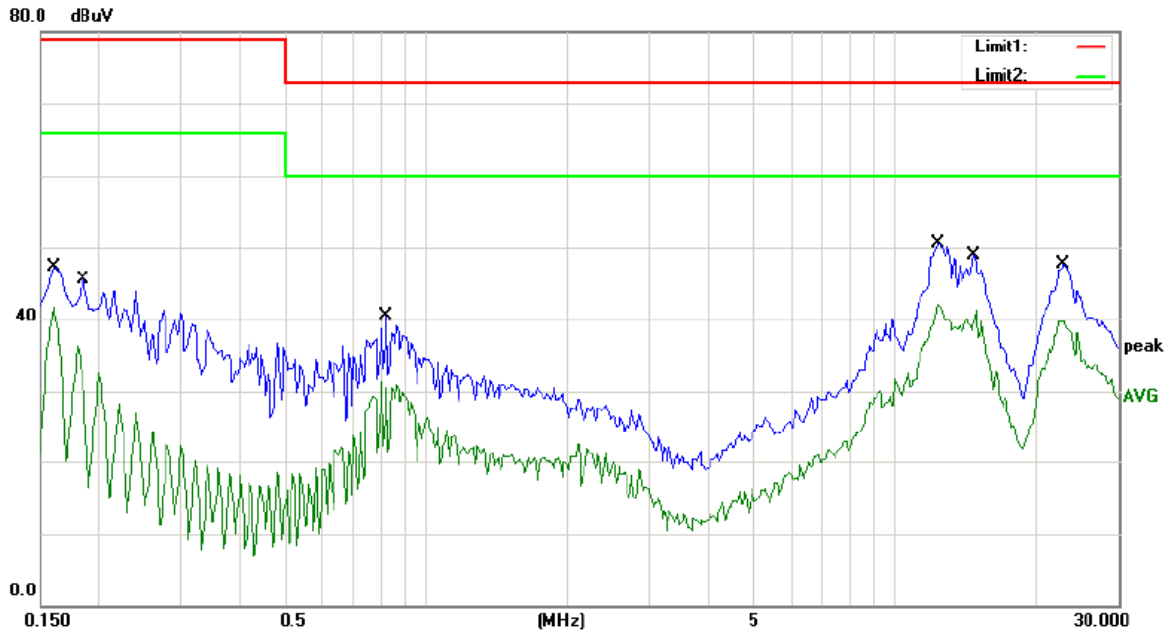

Site Conduction #2

Phase: **L1**

Temperature: 22

Limit: (CE)EN62040-2 C2_QP

Power: AC 230V/50Hz

Humidity: 53 %

Mode: LINE MODE

Note:

No.	Mk.	Freq. MHz	Reading Level dBuV	Correct Factor dB	Measure- ment dBuV	Limit dBuV	Over dB	Detector	Comment
1		0.1600	47.39	0.00	47.39	79.00	-31.61	QP	
2		0.1600	41.78	0.00	41.78	66.00	-24.22	AVG	
3		0.1850	45.60	0.00	45.60	79.00	-33.40	QP	
4		0.1850	36.34	0.00	36.34	66.00	-29.66	AVG	
5		0.8250	40.50	0.00	40.50	73.00	-32.50	QP	
6		0.8250	31.21	0.00	31.21	60.00	-28.79	AVG	
7		12.3750	50.55	0.00	50.55	73.00	-22.45	QP	
8	*	12.3750	42.13	0.00	42.13	60.00	-17.87	AVG	
9		14.8250	48.89	0.00	48.89	73.00	-24.11	QP	
10		14.8250	41.20	0.00	41.20	60.00	-18.80	AVG	
11		23.0000	47.63	0.00	47.63	73.00	-25.37	QP	
12		23.0000	39.74	0.00	39.74	60.00	-20.26	AVG	

*:Maximum data x:Over limit !:over margin Comment: Factor build in receiver. Operator: HE

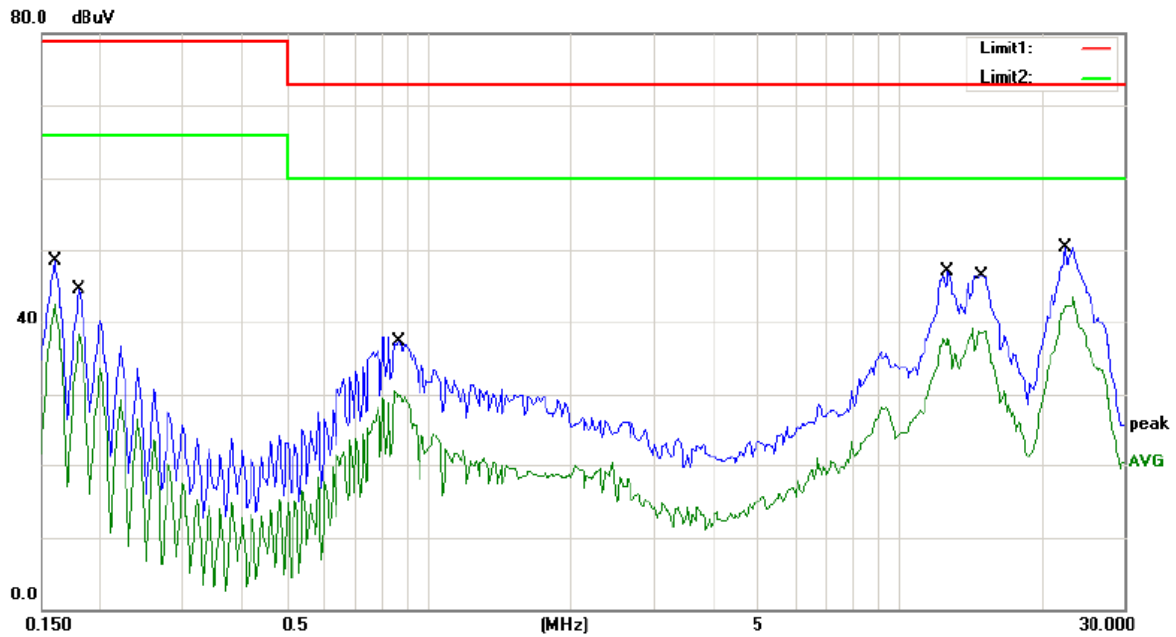

Site Conduction #2 Phase: **N** Temperature: 22
 Limit: (CE)EN62040-2 C2_QP Power: AC 230V/50Hz Humidity: 53 %
 Mode: LINE MODE
 Note:

No.	Mk.	Freq. MHz	Reading Level dBuV	Correct Factor dB	Measure- ment dBuV	Limit dBuV	Over dB	Detector	Comment
1		0.1600	48.59	0.00	48.59	79.00	-30.41	QP	
2		0.1600	42.53	0.00	42.53	66.00	-23.47	AVG	
3		0.1800	44.50	0.00	44.50	79.00	-34.50	QP	
4		0.1800	38.32	0.00	38.32	66.00	-27.68	AVG	
5		0.8650	37.29	0.00	37.29	73.00	-35.71	QP	
6		0.8650	29.90	0.00	29.90	60.00	-30.10	AVG	
7		12.7000	47.13	0.00	47.13	73.00	-25.87	QP	
8		12.7000	37.75	0.00	37.75	60.00	-22.25	AVG	
9		14.9750	46.57	0.00	46.57	73.00	-26.43	QP	
10		14.9750	38.66	0.00	38.66	60.00	-21.34	AVG	
11		22.6500	50.37	0.00	50.37	73.00	-22.63	QP	
12	*	22.6500	43.49	0.00	43.49	60.00	-16.51	AVG	

*:Maximum data x:Over limit !:over margin Comment: Factor build in receiver. Operator: HE

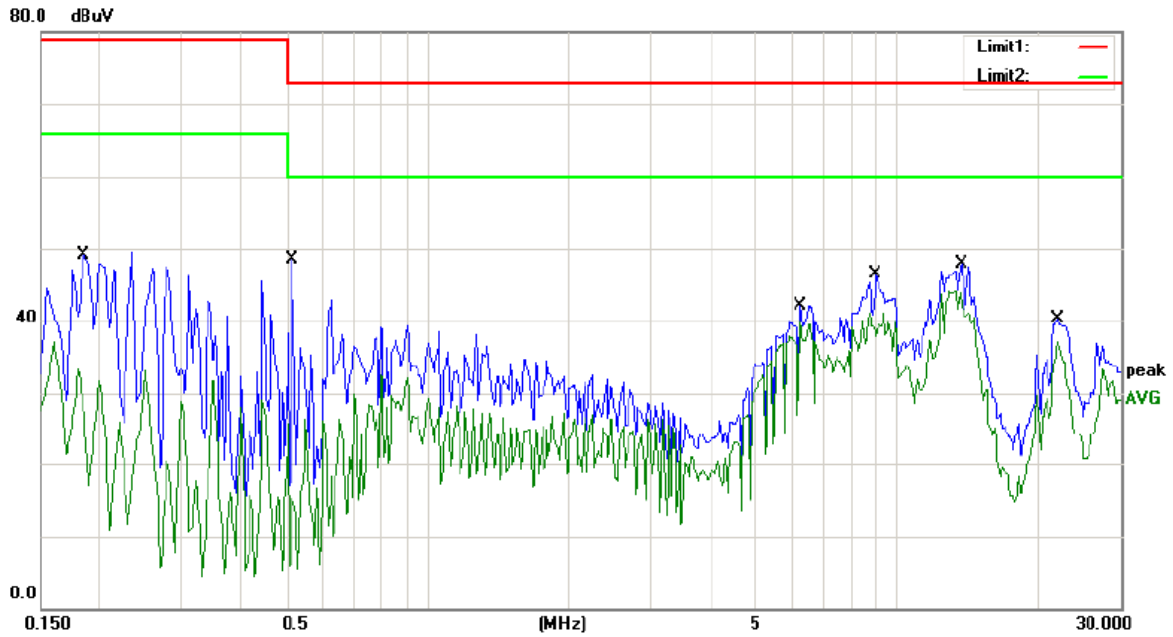

Site Conduction #2

Phase: **L1**

Temperature: 22

Limit: (CE)EN62040-2 C2_QP

Power: AC 230V/50Hz

Humidity: 53 %

Mode: BAT MODE

Note:

No.	Mk.	Freq. MHz	Reading Level dBuV	Correct Factor dB	Measure- ment dBuV	Limit dBuV	Over dB	Detector	Comment
1		0.1850	49.10	0.00	49.10	79.00	-29.90	QP	
2		0.1850	33.28	0.00	33.28	66.00	-32.72	AVG	
3		0.5150	48.41	0.00	48.41	73.00	-24.59	QP	
4		0.5150	26.23	0.00	26.23	60.00	-33.77	AVG	
5		6.2200	42.15	0.00	42.15	73.00	-30.85	QP	
6		6.2200	39.93	0.00	39.93	60.00	-20.07	AVG	
7		9.0300	46.53	0.00	46.53	73.00	-26.47	QP	
8		9.0300	41.15	0.00	41.15	60.00	-18.85	AVG	
9		13.7500	47.81	0.00	47.81	73.00	-25.19	QP	
10	*	13.7500	44.06	0.00	44.06	60.00	-15.94	AVG	
11		22.0750	40.37	0.00	40.37	73.00	-32.63	QP	
12		22.0750	37.05	0.00	37.05	60.00	-22.95	AVG	

*:Maximum data x:Over limit !:over margin Comment: Factor build in receiver. Operator: HE

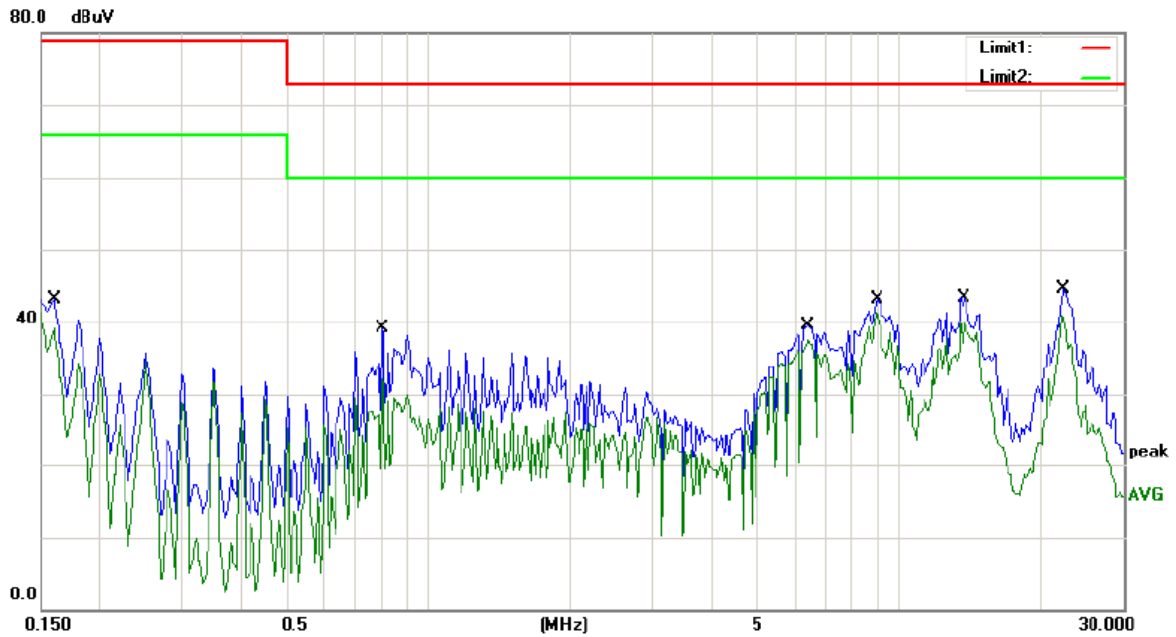

Site Conduction #2 Phase: **N** Temperature: 22
 Limit: (CE)EN62040-2 C2_QP Power: AC 230V/50Hz Humidity: 53 %
 Mode: BAT MODE
 Note:

No.	Mk.	Freq. MHz	Reading Level dBuV	Correct Factor dB	Measure- ment dBuV	Limit dBuV	Over dB	Detector	Comment
1		0.1600	43.15	0.00	43.15	79.00	-35.85	QP	
2		0.1600	39.01	0.00	39.01	66.00	-26.99	AVG	
3		0.8000	39.03	0.00	39.03	73.00	-33.97	QP	
4		0.8000	32.07	0.00	32.07	60.00	-27.93	AVG	
5		6.4200	39.52	0.00	39.52	73.00	-33.48	QP	
6		6.4200	37.53	0.00	37.53	60.00	-22.47	AVG	
7		9.0300	43.01	0.00	43.01	73.00	-29.99	QP	
8	*	9.0300	41.26	0.00	41.26	60.00	-18.74	AVG	
9		13.7500	43.39	0.00	43.39	73.00	-29.61	QP	
10		13.7500	40.00	0.00	40.00	60.00	-20.00	AVG	
11		22.4750	44.54	0.00	44.54	73.00	-28.46	QP	
12		22.4750	40.99	0.00	40.99	60.00	-19.01	AVG	

*:Maximum data x:Over limit !:over margin Comment: Factor build in receiver. Operator: HE

5. RADIATED EMISSION MEASUREMENT

5.1. Block Diagram of Test Setup

5.1.1. Block diagram of connection between the EUT and simulators



(EUT: Uninterruptible Power System)

5.1.2. Block diagram of test setup (In chamber)

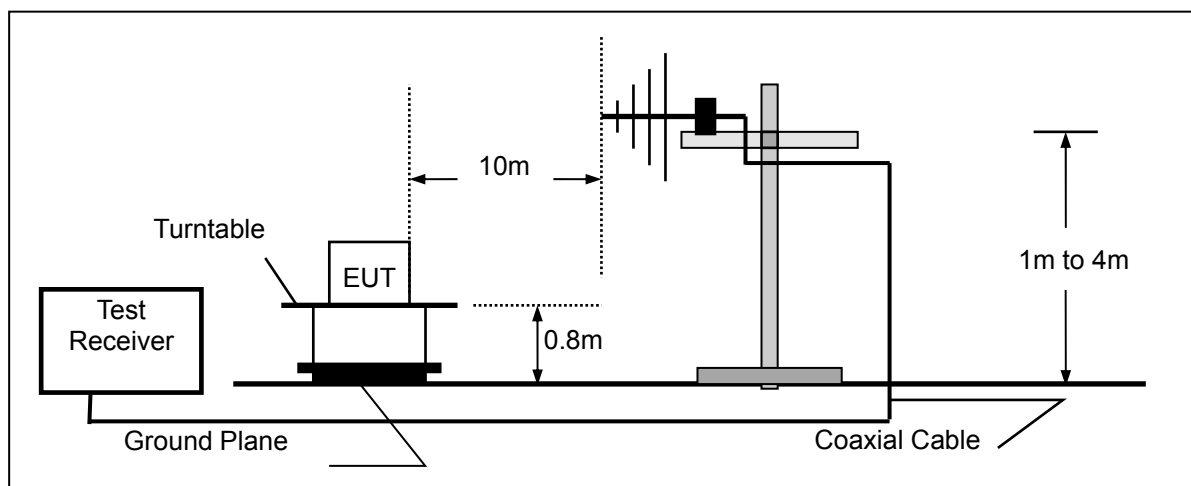

(EUT: Uninterruptible Power System)

5.2. Measuring Standard

EN 62040-2:2006 Category C2

5.3. Radiated Emission Limits

All emanations from device or system, including any network of conductors and apparatus connected thereto, shall not exceed the level of field strengths specified below:

FREQUENCY (MHz)	DISTANCE (Meters)	FIELD STRENGTHS LIMIT (dB μ V/m)
30 ~ 230	10	40
230 ~ 1000	10	47

Note: (1) The smaller limit shall apply at the combination point between two frequency bands.
(2) Distance refers to the distance in meters between the measuring instrument antenna and the closed point of any part of the EUT.

5.4. EUT Configuration on Test

The EN 62040-2 regulations test method must be used to find the maximum emission during radiated emission measurement.

5.5. Operating Condition of EUT

5.5.1. Turn on the power.

5.5.2. After that, let the EUT work in test mode (Line mode, Bat mode) and measure it.

5.6. Test Procedure

The EUT is placed on a turn table which is 0.8 meter high above the ground. The turn table can rotate 360 degrees to determine the position of the maximum emission level. The EUT is set 10 meters away from the receiving antenna which is mounted on an antenna tower. The antenna can be moved up and down from 1 to 4 meters to find out the maximum emission level. Bilog antenna (calibrated by Dipole Antenna) is used as a receiving antenna. Both horizontal and vertical polarization of the antenna are set on test.

The bandwidth of the Receiver is set at 120kHz.

All the scanning curves are attached in the following pages.

5.7. Measuring Results

PASS.

The frequency range from 30MHz to 1000MHz is investigated.

Please refer to the following pages.

Radiated Emission Measurement

1. Settings

Start: 30MHz	Stop: 1GHz	
RBW: 100KHz	VBW: 300KHz	Ref: 100
RFAtt: 10	PreAmp: True	Polarization: Horizontal
Tester: CSL	Model: HR1101.5L	Customer: TEL:
Test Time:2014/1/11 9:31	Temperature:20	Humidity:54
Power:AC 230V/50Hz	Test Distance:10M	EUT:UPS
Note:LINE MODE		

2. Chart

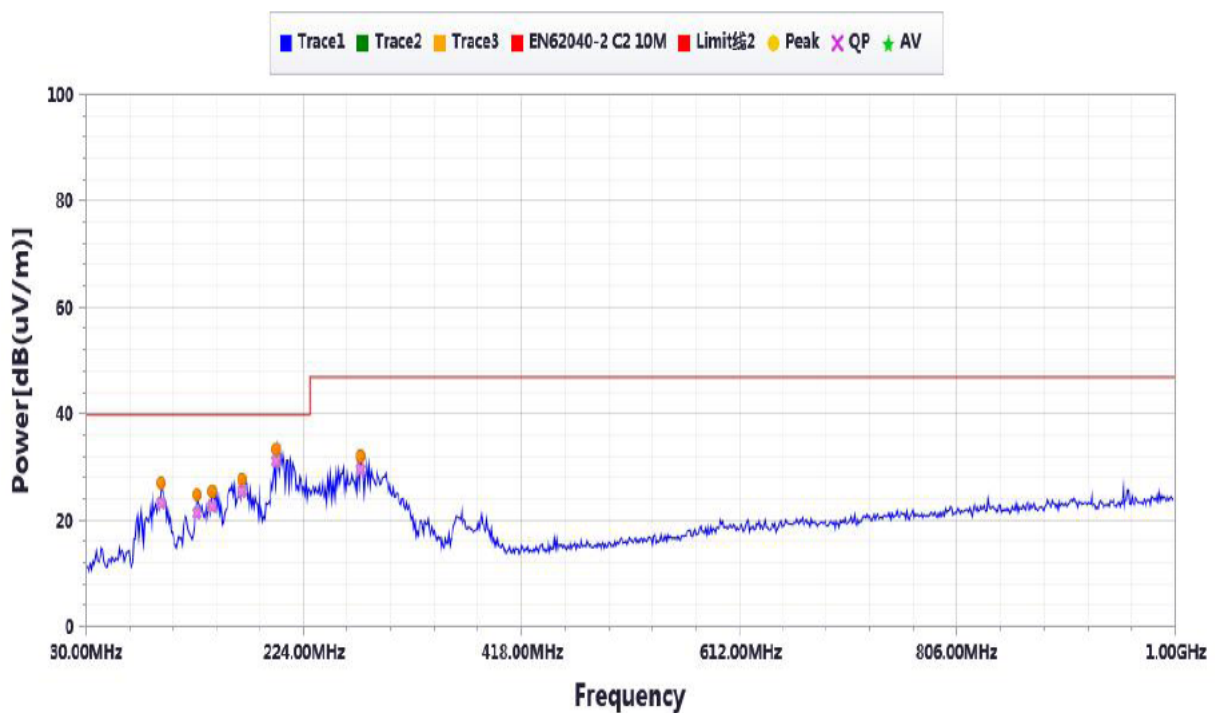

3. Result

Frequency Hz	Peak dB(uV/m)	QP dB(uV/m)	Fac	Res	Limit1 dB(uV/m)	Pe. L1	Qp. L1	Deg. °	Hig. cm	Result
97.83MHz	26.99	23.5	-31.06	58.05	40	13.01	16.5			Pass
129.81MHz	24.81	21.3	-34.06	58.87	40	15.19	18.7			Pass
143.38MHz	25.69	22.7	-34.39	60.08	40	14.31	17.3			Pass
169.54MHz	27.87	25.6	-32.77	60.64	40	12.13	14.4			Pass
200.55MHz	33.57	31.2	-30.31	63.88	40	6.43	8.8			Pass
275.16MHz	32.04	29.6	-28.24	60.28	47	14.96	17.4			Pass

Radiated Emission Measurement

1. Settings

Start: 30MHz	Stop: 1GHz	
RBW: 100KHz	VBW: 300KHz	Ref: 100
RFAAtt: 10	PreAmp: True	Polarization: Vertical
Tester: CSL	Model: HR1101.5L	Customer: TEL:
Test Time:2014/1/11 9:31	Temperature:20	Humidity:54
Power:AC 230V/50Hz	Test Distance:10M	EUT:UPS
Note:LINE MODE		

2. Chart

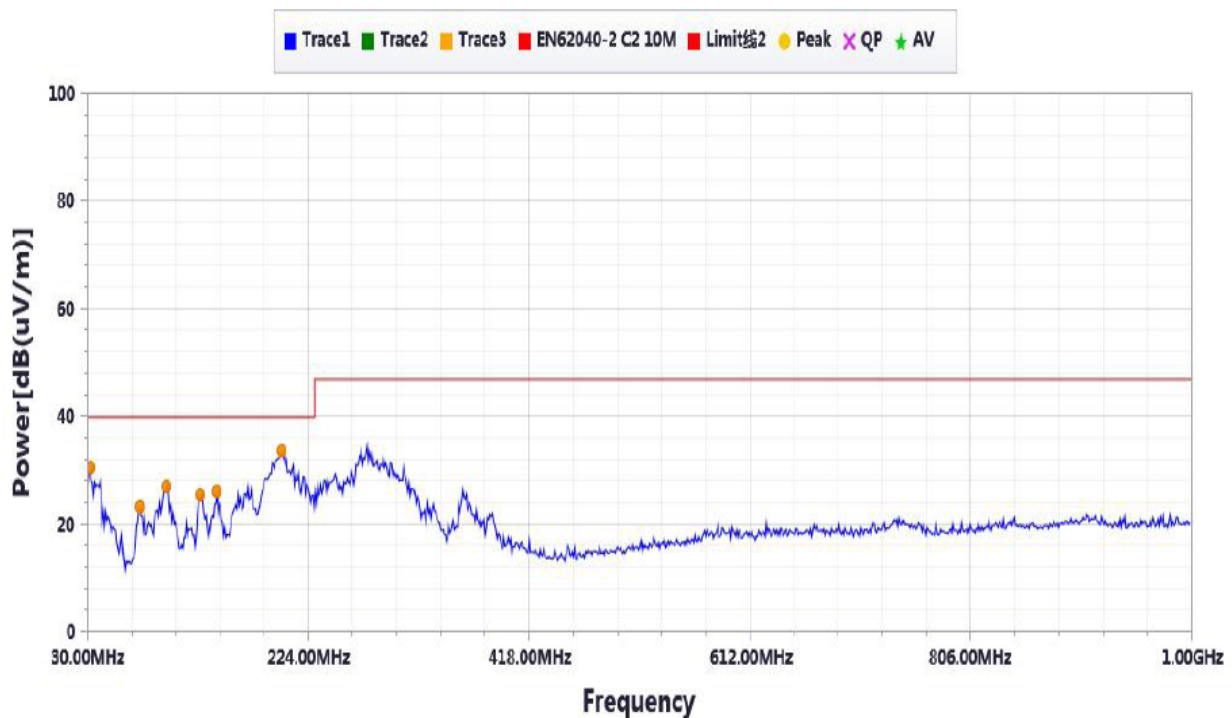

3. Result

Frequency Hz	Peak dB (uV/m)	QP dB (uV/m)	Fac	Res	Limit1 dB (uV/m)	Pe. L1	Qp. L1	Deg. °	Hig. cm	Result
32.91MHz	30.6	26.5	-32.74	63.34	40	9.4	13.5			Pass
76.51MHz	23.36	20.1	-35.78	59.14	40	16.64	19.9			Pass
99.77MHz	27.25	24.7	-31.42	58.67	40	12.75	15.3			Pass
128.84MHz	25.54	22.1	-34.83	60.37	40	14.46	17.9			Pass
144.35MHz	26.03	23.7	-35.38	61.41	40	13.97	16.3			Pass
201.52MHz	33.74	30	-31.53	65.27	40	6.26	10			Pass

Radiated Emission Measurement

1. Settings

Start: 30MHz	Stop: 1GHz	
RBW: 100KHz	VBW: 300KHz	Ref: 100
RFAtt: 10	PreAmp: True	Polarization: Horizontal
Tester: CSL	Model: HR1101.5L	Customer: TEL:
Test Time:2014/1/11 9:35	Temperature:20	Humidity:54
Power:AC 230V/50Hz	Test Distance:10M	EUT:UPS
Note:BAT MODE		

2. Chart

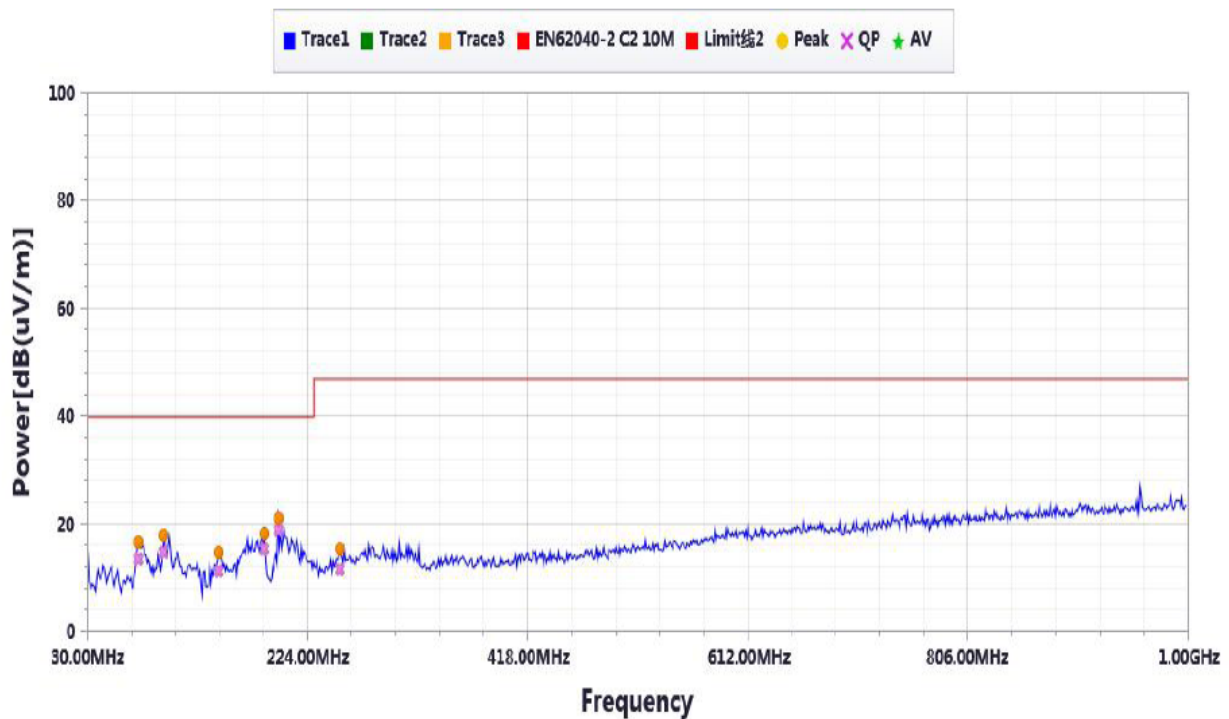

3. Result

Frequency Hz	Peak dB (uV/m)	QP dB (uV/m)	Fac	Res	Limit1 dB (uV/m)	Pe. L1	Qp. L1	Deg. °	Hig. cm	Result
75.54MHz	16.6	13.5	-35.15	51.75	40	23.4	26.5			Pass
97.83MHz	17.89	14.7	-31.06	48.95	40	22.11	25.3			Pass
146.28MHz	14.89	11.2	-34.32	49.21	40	25.11	28.8			Pass
186.01MHz	18.27	15.6	-31.52	49.79	40	21.73	24.4			Pass
198.61MHz	21.22	18.9	-30.36	51.58	40	18.78	21.1			Pass
252.88MHz	15.43	11.7	-28.71	44.14	47	31.57	35.3			Pass

Radiated Emission Measurement

1. Settings

Start: 30MHz	Stop: 1GHz	
RBW: 100KHz	VBW: 300KHz	Ref: 100
RFAtt: 10	PreAmp: True	Polarization: Vertical
Tester: CSL	Model: HR1101.5L	Customer: TEL:
Test Time:2014/1/11 9:35	Temperature:20	Humidity:54
Power:AC 230V/50Hz	Test Distance:10M	EUT:UPS
Note:BAT MODE		

2. Chart

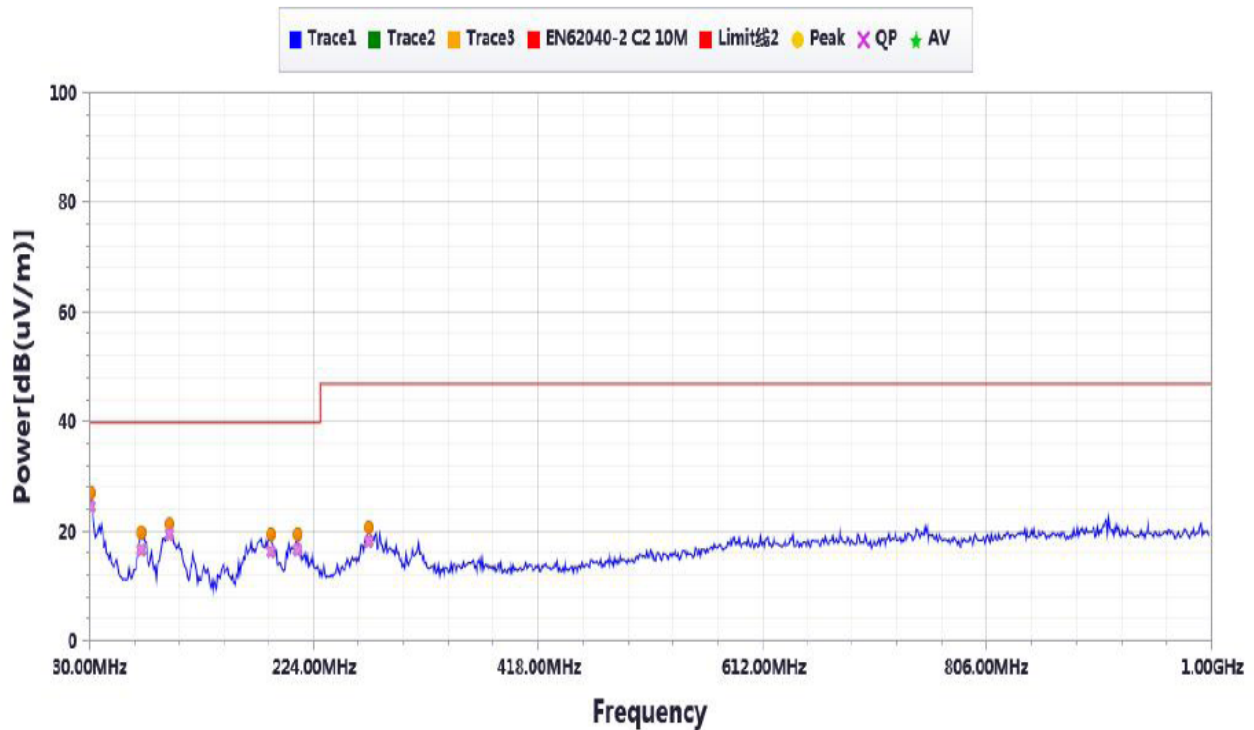

3. Result

Frequency Hz	Peak dB (uV/m)	QP dB (uV/m)	Fac	Res	Limit1 dB (uV/m)	Pe. L1	Qp. L1	Deg. °	Hig. cm	Result
31.94MHz	27.2	24.5	-32.83	60.03	40	12.8	15.5			Pass
75.54MHz	19.83	16.8	-35.68	55.51	40	20.17	23.2			Pass
99.77MHz	21.42	19.7	-31.42	52.84	40	18.58	20.3			Pass
186.98MHz	19.52	16.3	-32.34	51.86	40	20.48	23.7			Pass
210.24MHz	19.56	16.7	-31.77	51.33	40	20.44	23.3			Pass
272.26MHz	20.8	18.4	-29.45	50.25	47	26.2	28.6			Pass

6. HARMONIC CURRENT EMISSION MEASUREMENT

6.1. Block Diagram of Test Setup

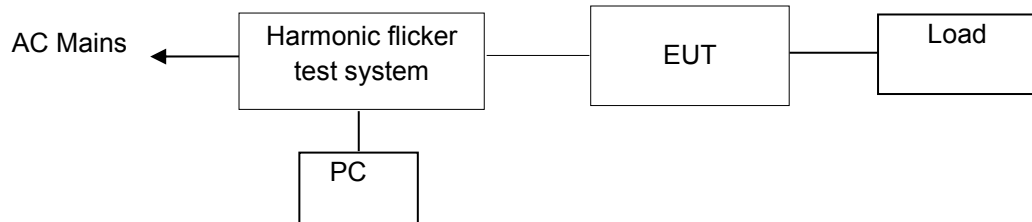

(EUT: Uninterruptible Power System)

6.2. Measuring Standard

EN 61000-3-2:2014 CLASS A

6.3. Operation Condition of EUT

Same as Section 4.4, except the test setup replaced as Section 6.1.

6.4. Measuring Results

PASS.

Please see the attached pages.

Harmonics – Class-A per Ed. 4.0 (2014)(Run time)

EUT: UPS(HR1103S) Tested by: GFH
 Test category: Class-A per Ed. 4.0 (2014) (European limits) Test Margin: 100
 Test date: 2016/5/25 Start time: 14:51:33 End time: 14:54:25
 Test duration (min): 2.5 Data file name: WIN2105_H-000577.cts_data
 Comment: ON
 Customer: INVT

Test Result: Pass Source qualification: Distorted

Current & voltage waveforms

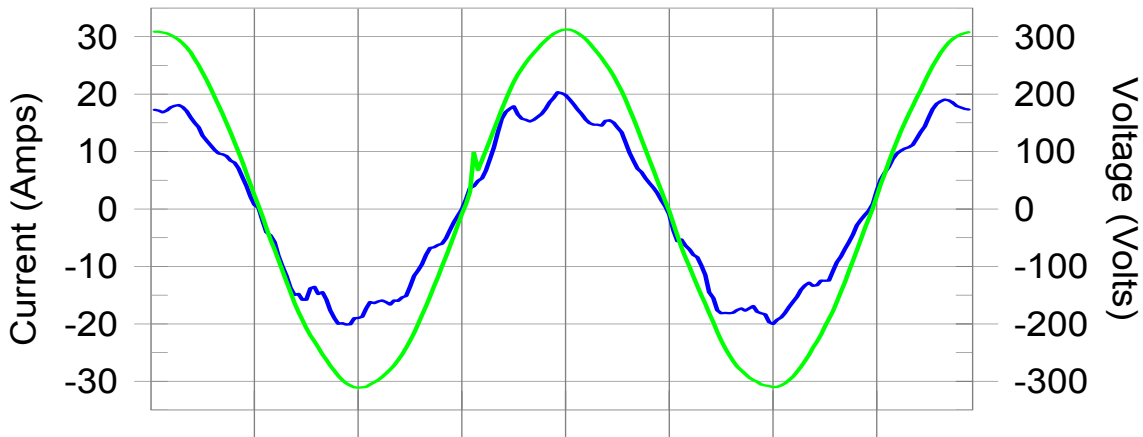

Harmonics and Class A limit line European Limits

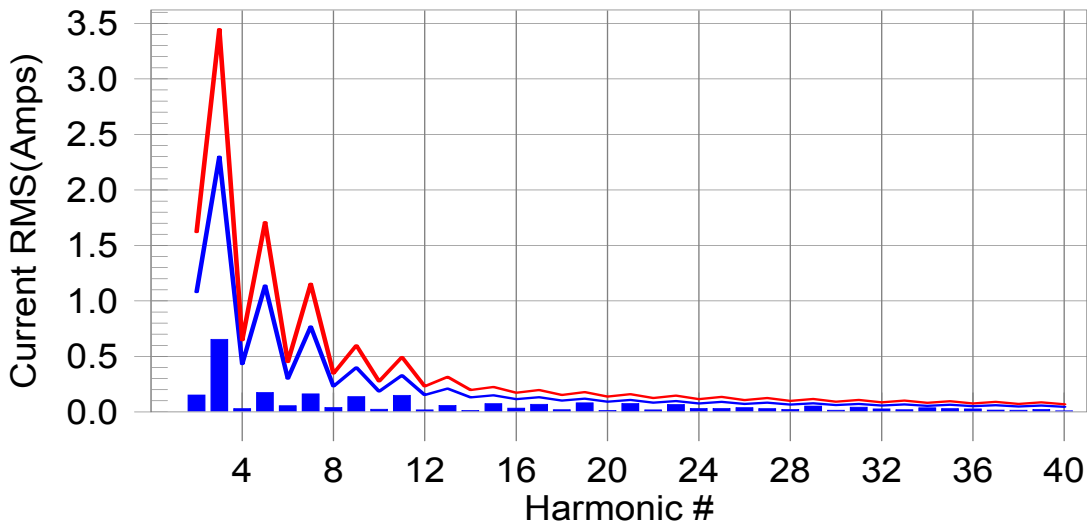

Test result: Pass Worst harmonic was #21 with 71.7% of the limit.

Current Test Result Summary (Run time)

EUT: UPS(HR1103S) Tested by: GFH
 Test category: Class-A per Ed. 4.0 (2014) (European limits) Test Margin: 100
 Test date: 2016/5/25 Start time: 14:51:33 End time: 14:54:25
 Test duration (min): 2.5 Data file name: WIN2105_H-000577.cts_data
 Comment: ON
 Customer: INVT

Test Result: Pass Source qualification: Distorted
 THC: 0.778 A I-THD: 5.7 % POHC(A): 0.139 A POHC Limit(A): 0.251 A

Highest parameter values during test:
 V_RMS (Volts): 219.454 Frequency(Hz): 50.00
 I_Peak (Amps): 27.106 I_RMS (Amps): 13.612
 I_Fund (Amps): 13.541 Crest Factor: 1.992
 Power (Watts): 2964.2 Power Factor: 0.993

Harm#	Harms(avg)	100%Limit	%of Limit	Harms(max)	150%Limit	%of Limit	Status
2	0.152	1.080	14.0	0.179	1.620	11.0	Pass
3	0.654	2.300	28.4	0.675	3.450	19.6	Pass
4	0.031	0.430	7.2	0.055	0.645	8.6	Pass
5	0.176	1.140	15.5	0.244	1.710	14.3	Pass
6	0.056	0.300	18.8	0.067	0.450	14.9	Pass
7	0.162	0.770	21.1	0.306	1.155	26.5	Pass
8	0.040	0.230	17.4	0.065	0.345	18.9	Pass
9	0.138	0.400	34.5	0.281	0.600	46.9	Pass
10	0.024	0.184	13.1	0.045	0.276	16.2	Pass
11	0.149	0.330	45.1	0.184	0.495	37.2	Pass
12	0.018	0.153	11.6	0.038	0.230	16.6	Pass
13	0.058	0.210	27.7	0.076	0.315	24.2	Pass
14	0.014	0.131	10.8	0.024	0.197	12.4	Pass
15	0.074	0.150	49.6	0.089	0.225	39.4	Pass
16	0.034	0.115	29.8	0.043	0.173	25.0	Pass
17	0.069	0.132	52.2	0.085	0.198	43.1	Pass
18	0.020	0.102	19.2	0.032	0.153	21.1	Pass
19	0.081	0.118	68.6	0.091	0.178	51.1	Pass
20	0.014	0.092	15.6	0.022	0.138	15.6	Pass
21	0.077	0.107	71.7	0.091	0.161	56.4	Pass
22	0.018	0.084	22.0	0.027	0.125	21.3	Pass
23	0.068	0.098	69.3	0.084	0.147	57.1	Pass
24	0.032	0.077	41.2	0.040	0.115	35.1	Pass
25	0.032	0.090	35.1	0.041	0.135	30.2	Pass
26	0.038	0.071	53.9	0.047	0.107	44.4	Pass
27	0.031	0.083	37.0	0.040	0.125	32.0	Pass
28	0.022	0.066	33.7	0.036	0.099	36.3	Pass
29	0.053	0.078	68.5	0.065	0.116	56.3	Pass
30	0.016	0.061	26.1	0.029	0.092	32.0	Pass
31	0.043	0.073	59.2	0.054	0.109	49.4	Pass
32	0.027	0.058	47.4	0.035	0.086	40.9	Pass
33	0.021	0.068	30.1	0.028	0.102	27.3	Pass
34	0.037	0.054	68.2	0.043	0.081	52.6	Pass
35	0.030	0.064	46.7	0.036	0.096	37.5	Pass
36	0.026	0.051	51.6	0.033	0.077	43.2	Pass
37	0.017	0.061	28.3	0.022	0.091	24.0	Pass
38	0.016	0.048	32.3	0.023	0.073	32.2	Pass
39	0.023	0.058	40.1	0.033	0.087	37.7	Pass
40	0.010	0.046	21.6	0.015	0.069	22.3	Pass

Voltage Source Verification Data (Run time)

EUT: UPS(HR1103S) Tested by: GFH
Test category: Class-A per Ed. 4.0 (2014) (European limits) Test Margin: 100
Test date: 2016/5/25 Start time: 14:51:33 End time: 14:54:25
Test duration (min): 2.5 Data file name: WIN2105_H-000577.cts_data
Comment: ON
Customer: INVT

Test Result: Pass **Source qualification: Distorted**

Highest parameter values during test:

Voltage (Vrms): 219.454	Frequency(Hz): 50.00
I_Peak (Amps): 27.106	I_RMS (Amps): 13.612
I_Fund (Amps): 13.541	Crest Factor: 1.992
Power (Watts): 2964.2	Power Factor: 0.993

Harm#	Harmonics V-rms	Limit V-rms	% of Limit	Status
2	0.108	0.439	24.55	OK
3	0.231	1.975	11.72	OK
4	0.091	0.439	20.78	OK
5	0.411	0.878	46.79	OK
6	0.100	0.439	22.78	OK
7	1.105	0.658	167.85	Dist.
8	0.122	0.439	27.84	OK
9	0.900	0.439	205.14	Dist.
10	0.067	0.439	15.24	OK
11	0.380	0.219	173.17	Dist.
12	0.056	0.219	25.41	OK
13	0.238	0.219	108.61	Marg.
14	0.053	0.219	24.31	OK
15	0.142	0.219	64.55	OK
16	0.073	0.219	33.30	OK
17	0.158	0.219	71.90	OK
18	0.065	0.219	29.57	OK
19	0.152	0.219	69.36	OK
20	0.063	0.219	28.88	OK
21	0.164	0.219	74.59	OK
22	0.070	0.219	31.99	OK
23	0.171	0.219	78.06	OK
24	0.076	0.219	34.76	OK
25	0.102	0.219	46.42	OK
26	0.071	0.219	32.18	OK
27	0.099	0.219	45.29	OK
28	0.071	0.219	32.32	OK
29	0.124	0.219	56.32	OK
30	0.074	0.219	33.93	OK
31	0.097	0.219	44.08	OK
32	0.072	0.219	32.77	OK
33	0.079	0.219	35.82	OK
34	0.088	0.219	40.30	OK
35	0.093	0.219	42.52	OK
36	0.084	0.219	38.21	OK
37	0.085	0.219	38.79	OK
38	0.056	0.219	25.49	OK
39	0.089	0.219	40.62	OK
40	0.051	0.219	23.04	OK

7. VOLTAGE FLUCTUATION AND FLICKER MEASUREMENT

7.1. Block Diagram of Test Setup

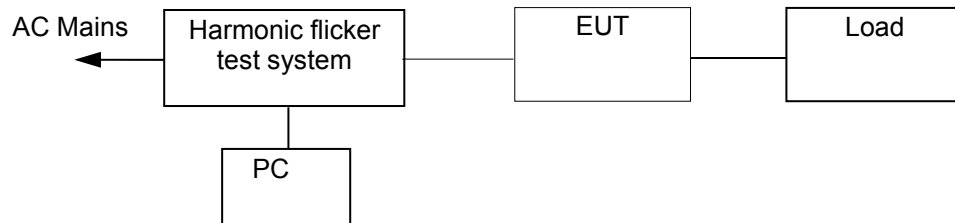

(EUT: Uninterruptible Power System)

7.2. Measuring Standard

EN 61000-3-3:2013

7.3. Operation Condition of EUT

Same as Section 4.4, except the test setup replaced as Section 7.1.

7.4. Measuring Results

PASS.

Please see the attached page.

Flicker Test Summary per EN/IEC61000-3-3 (Run time)

EUT: UPS(HR1103S)	Tested by: YU
Test category: All parameters (European limits)	Test Margin: 100
Test date: 2014-1-13	Start time: 01:40:25
Test duration (min): 10	End time: 01:50:46
Comment: FULL LOAD	Data file name: WIN2105_F-000032.cts_data
Customer: YWT	

Test Result: Pass

Status: Test Completed

Pst_i and limit line

European Limits

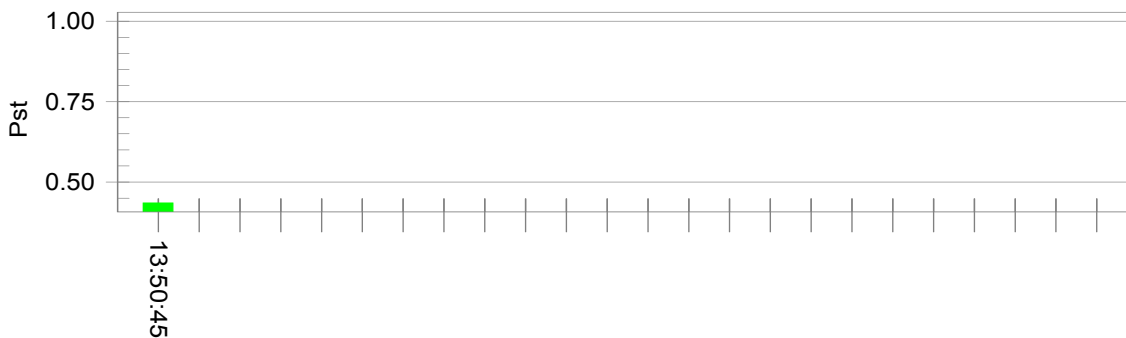

Plt and limit line

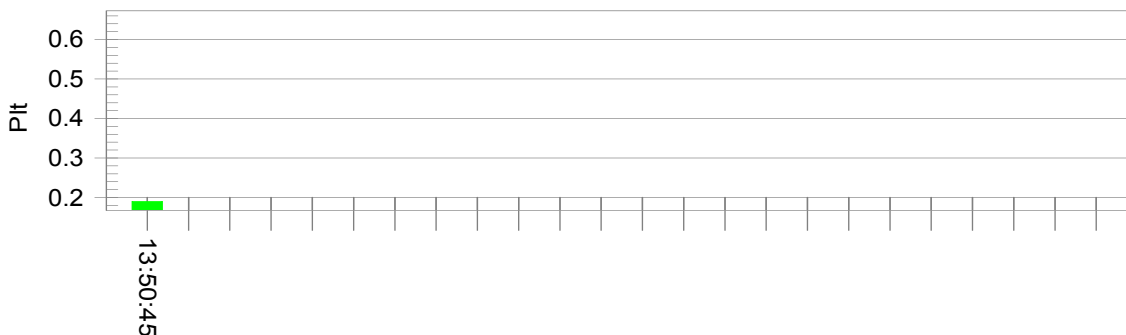

Parameter values recorded during the test:

Vrms at the end of test (Volt): 228.65

Time(mS) > dt (3.3%):	0.0	Test limit (mS):	500.0	Pass
Highest dc (%):	0.32	Test limit (%):	3.30	Pass
Highest dmax (%):	0.73	Test limit (%):	4.00	Pass
Highest Pst (10 min. period):	0.435	Test limit:	1.000	Pass
Highest Plt (2 hr. period):	0.190	Test limit:	0.650	Pass

8. IMMUNITY PERFORMANCE CRITERIA DESCRIPTION

Performance Level

The test results shall be classified in terms of the loss of function or degradation of performance of the equipment under test, relative to a performance level by its manufacturer or the requestor of the test, or the agreed between the manufacturer and the purchaser of the product.

Definition related to the performance level:

1. Based on the used product standard
2. Based on the declaration of the manufacturer, requestor or purchaser

Criterion A:

Definition: normal performance within limits specified by the manufacturer, requestor and purchaser.

The equipment shall continue to operate as intended without operator intervention. No degradation of performance or loss of function is allowed below a performance level specified by the manufacturer when the equipment is used as intended. The performance level may be replaced by a permissible loss of performance. If the minimum performance level or the permissible performance loss is not specified by the manufacturer, then either of these may be derived from the product description and documentation, and by what the user may reasonably expect from the equipment if used as intended.

Criterion B:

Definition: temporary loss of function or degradation of performance which ceases after the disturbance ceases, and from which the equipment under test recovers its normal performance, without operator intervention.

After the test, the EUT shall continue to operate as intended without operator intervention. No degradation of performance or loss of function is allowed, after the application of the phenomena below a performance level specified by the manufacturer, when the EUT is used as intended. The performance level may be replaced by a permissible loss of performance. During the test, degradation of performance is allowed. However, no change of operating state or stored data is allowed to persist after the test. If the minimum performance level (or the permissible performance loss) is not specified by the manufacturer, then either of these may be derived from the product description and documentation, and by what the user may reasonably expect from the EUT if used as intended.

Criterion C:

Definition: temporary loss of function or degradation of performance, the correction of which requires operator intervention.

Loss of function is allowed, provided the function is self-recoverable, or can be restored by the operation of the controls by the user in accordance with the manufacturer's instructions. Functions, and/or information stored in non-volatile memory, or protected by a battery backup, shall not be lost.

Criterion D

Definition: loss of function or degradation of performance, which is not recoverable, owing to damage to hardware or software, or loss of data.

9. ELECTROSTATIC DISCHARGE IMMUNITY TEST

9.1. Block Diagram of Test Setup

9.1.1. Block diagram of connection between the EUT and simulators



(EUT: Uninterruptible Power System)

9.1.2. Block diagram of ESD test setup

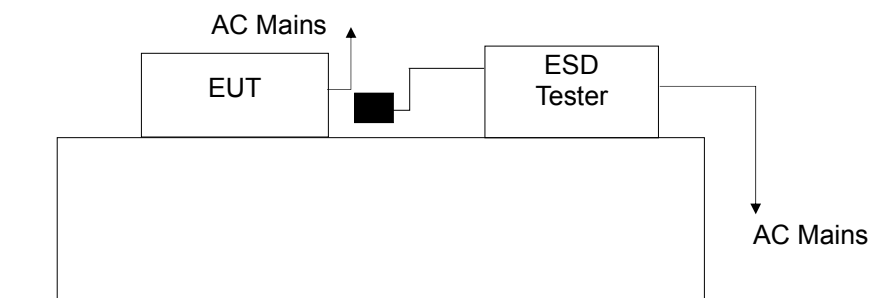

(EUT: Uninterruptible Power System)

9.2. Test Standard

IEC 61000-4-2:2008 (Air Discharge: ± 8 kV, Contact Discharge: ± 4 kV)

9.3. Severity Levels and Performance Criterion

9.3.1. Severity level

Level	Test Voltage Contact Discharge (kV)	Test Voltage Air Discharge (kV)
1	± 2	± 2
2	± 4	± 4
3	± 6	± 8
4	± 8	± 15
X	Special	Special

9.3.2. Performance criterion: B

Performance criteria for immunity tests

	Criterion A	Criterion B
Output characteristics	Voltage permitted to vary only within the steady-state characteristics applicable (100 m sec limits in Figures 1, 2 or 3 of IEC 62040-3)	Voltage permitted to vary within the inverse time characteristics applicable (<100 m sec limits in Figures 1, 2 or 3 of IEC 62040-3)
External and internal indications and metering	Change only during test	Change only during test
Control signals to external devices	No change	Change only temporarily in consistency with the actual UPS mode of operation
Mode of operation	No change	Change only temporarily

9.4. EUT Configuration

The configurations of EUT are listed in Section 4.3.

9.5. Operating Condition of EUT

Same as conducted emission measurement, which is listed in Section 4.4. except the test set up was replaced by Section 9.1.

9.6. Test Procedure

9.6.1. Air Discharge:

This test is done on a non-conductive surface. The round discharge tip of the discharge electrode shall be approached as fast as possible to touch the EUT.

After each discharge, the discharge electrode shall be removed from the EUT.

The generator is then re-triggered for a new single discharge and repeated 10 times for each pre-selected test point. This procedure shall be repeated until all the air discharge completed

9.6.2. Contact Discharge:

All the procedure shall be same as Section 9.6.1. Except that the tip of the discharge electrode shall touch the EUT before the discharge switch is operated.

9.6.3. Indirect discharge for horizontal coupling plane

At least 10 single discharges (in the most sensitive polarity) shall be applied at the front edge of each HCP opposite the center point of each unit (if applicable) of the EUT and 0.1m from the front of the EUT. The long axis of the discharge electrode shall be in the plane of the HCP and perpendicular to its front edge during the discharge.

9.6.4. Indirect discharge for vertical coupling plane

At least 10 single discharge (in the most sensitive polarity) shall be applied to the center of one vertical edge of the coupling plane. The coupling plane, of dimensions 0.5m X 0.5m, is placed parallel to, and positioned at a distance of 0.1m from the EUT. Discharges shall be applied to the coupling plane, with this plane in sufficient different positions that the four faces of the EUT are completely illuminated.

9.7. Test Results

PASS

Please refer to the following page.

Electrostatic Discharge Test Result

EMTEK(SHENZHEN) CO., LTD.

Applicant : INVT POWER SYSTEM (SHENZHEN) CO., LTD. <hr/> EUT : Uninterruptible Power System <hr/> M/N : HR1103S <hr/> Power Supply : AC 230V/50Hz <hr/> Test Mode : Line mode, Bat mode <hr/> Test Engineer : He	Test Date : January 13, 2014 <hr/> Temperature : 22°C <hr/> Humidity : 50% <hr/> Criterion : B <hr/> Air discharge : ±8.0kV <hr/> Contact discharge : ±4.0kV	
Location	Kind A-Air Discharge C-Contact Discharge	Result
Slot	A	A
Port	A,C	A
Metal	C	A
Button	A	A
Screen	A	A
HCP	C	A
VCP of front	C	A
VCP of rear	C	A
VCP of left	C	A
VCP of right	C	A

10. RF FIELD STRENGTH SUSCEPTIBILITY TEST

10.1. Block Diagram of Test Setup

10.1.1. Block diagram of connection between the EUT and Load

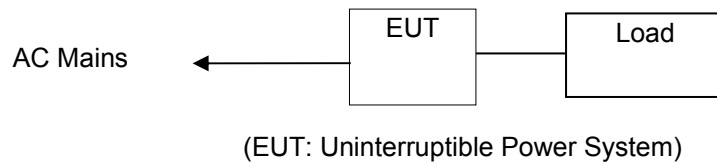

10.1.2. Block diagram of RS test setup

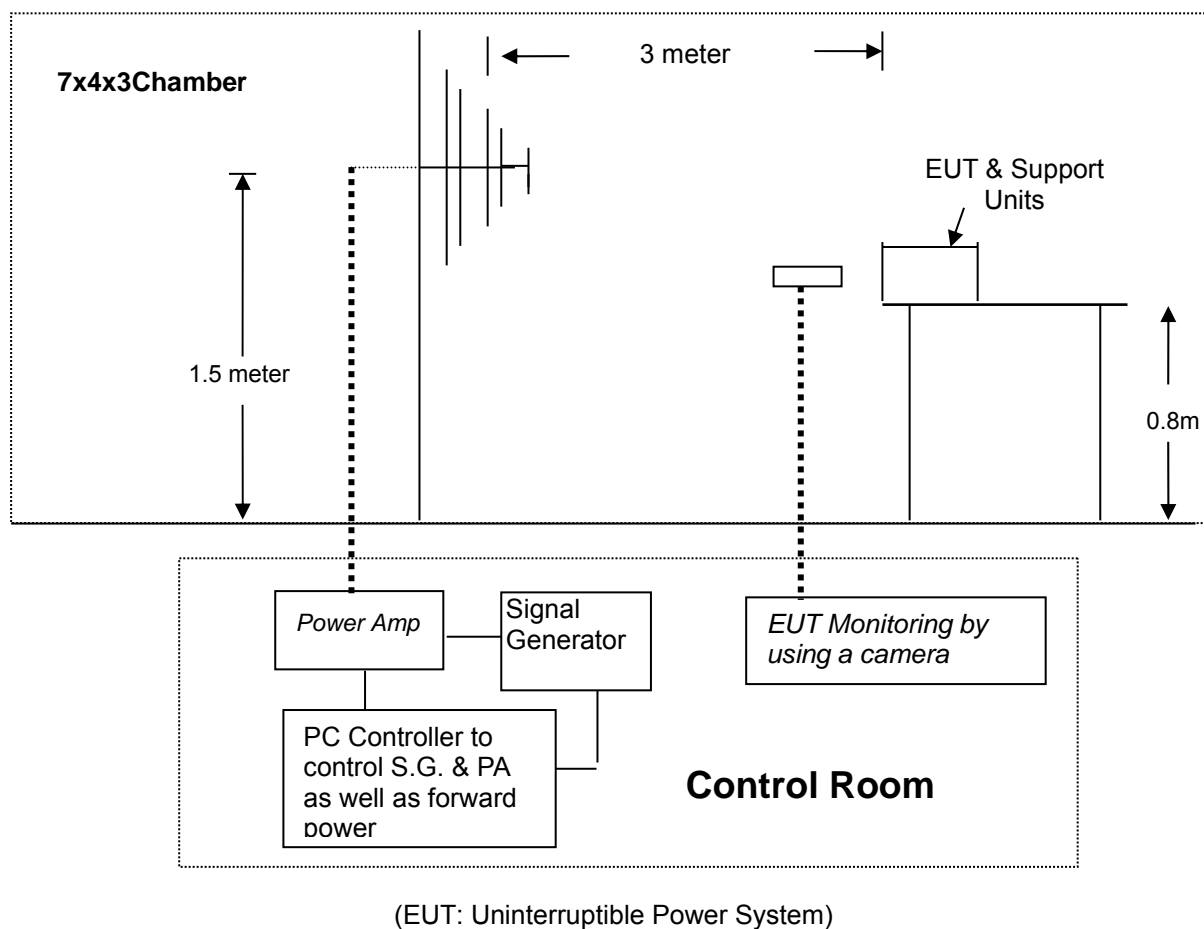

10.2. Test Standard

IEC 61000-4-3:2006+A1:2007+A2:2010 (Level 3: 10V/m)

10.3. Severity Levels and Performance Criterion

10.3.1. Severity Levels

Level	Field Strength V/m
1.	1
2.	3
3.	10
X	Special

10.3.2. Performance Criterion: A

Performance criteria for immunity tests

	Criterion A	Criterion B
Output characteristics	Voltage permitted to vary only within the steady-state characteristics applicable (100 m sec limits in Figures 1, 2 or 3 of IEC 62040-3)	Voltage permitted to vary within the inverse time characteristics applicable (<100 m sec limits in Figures 1, 2 or 3 of IEC 62040-3)
External and internal indications and metering	Change only during test	Change only during test
Control signals to external devices	No change	Change only temporarily in consistency with the actual UPS mode of operation
Mode of operation	No change	Change only temporarily

10.4. EUT Configuration on Test

The configuration of the EUT is same as Section 4.3.

10.5. Operating Condition of EUT

Same as radiated emission measurement which is listed in Section 4.4, except the test setup replaced as Section 10.1.

10.6. Test Procedure

The EUT are placed on a table which is 0.8 meter high above the ground. The EUT is set 3 meters away from the transmitting antenna which is mounted on an antenna tower. Both horizontal and vertical polarization of the antenna are set on test. Each of the four sides of the EUT must be faced this transmitting antenna and measured individually.

In order to judge the EUT performance, a CCD camera is used to monitor it.

All the scanning conditions are as following:

Condition of Test	Remark
1. Fielded Strength	10V/m
2. Radiated Signal	Modulated
3. Scanning Frequency	80-1000MHz
4. Sweep time of radiated	0.0015 Decade/s
5. Dwell Time	1 Sec.

10.7. Test Results

PASS.

Please refer to the following page.

RF Field Strength Susceptibility Test Results

EMTEK(SHENZHEN) CO., LTD.

<table style="width: 100%; border-collapse: collapse;"> <tr><td style="border-bottom: 1px solid black;">Applicant</td><td style="border-bottom: 1px solid black;">: INVT POWER SYSTEM (SHENZHEN) CO., LTD.</td></tr> <tr><td style="border-bottom: 1px solid black;">EUT</td><td style="border-bottom: 1px solid black;">: Uninterruptible Power System</td></tr> <tr><td style="border-bottom: 1px solid black;">M/N</td><td style="border-bottom: 1px solid black;">: HR1103S</td></tr> <tr><td style="border-bottom: 1px solid black;">Field Strength</td><td style="border-bottom: 1px solid black;">: 10V/m</td></tr> <tr><td style="border-bottom: 1px solid black;">Power Supply</td><td style="border-bottom: 1px solid black;">: AC 230V/50Hz</td></tr> <tr><td style="border-bottom: 1px solid black;">Test Engineer</td><td style="border-bottom: 1px solid black;">: HE</td></tr> </table>	Applicant	: INVT POWER SYSTEM (SHENZHEN) CO., LTD.	EUT	: Uninterruptible Power System	M/N	: HR1103S	Field Strength	: 10V/m	Power Supply	: AC 230V/50Hz	Test Engineer	: HE	<table style="width: 100%; border-collapse: collapse;"> <tr><td style="border-bottom: 1px solid black;">Test Mode:</td><td style="border-bottom: 1px solid black;">Line mode, Bat mode</td></tr> <tr><td style="border-bottom: 1px solid black;">Temperature:</td><td style="border-bottom: 1px solid black;">22°C</td></tr> <tr><td style="border-bottom: 1px solid black;">Humidity :</td><td style="border-bottom: 1px solid black;">50%</td></tr> <tr><td style="border-bottom: 1px solid black;">Criterion:</td><td style="border-bottom: 1px solid black;">A</td></tr> <tr><td style="border-bottom: 1px solid black;">Test Date</td><td style="border-bottom: 1px solid black;">January 13, 2014</td></tr> <tr><td style="border-bottom: 1px solid black;">Frequency Range:</td><td style="border-bottom: 1px solid black;">80 to 1000 MHz</td></tr> </table>	Test Mode:	Line mode, Bat mode	Temperature:	22°C	Humidity :	50%	Criterion:	A	Test Date	January 13, 2014	Frequency Range:	80 to 1000 MHz
Applicant	: INVT POWER SYSTEM (SHENZHEN) CO., LTD.																								
EUT	: Uninterruptible Power System																								
M/N	: HR1103S																								
Field Strength	: 10V/m																								
Power Supply	: AC 230V/50Hz																								
Test Engineer	: HE																								
Test Mode:	Line mode, Bat mode																								
Temperature:	22°C																								
Humidity :	50%																								
Criterion:	A																								
Test Date	January 13, 2014																								
Frequency Range:	80 to 1000 MHz																								
Modulation: <input type="checkbox"/> None <input type="checkbox"/> Pulse <input checked="" type="checkbox"/> AM 1kHz 80%																									
	Frequency Rang 1: 80~ 1000MHz	Frequency Rang 2: N/A																							
	Horizontal	Vertical	Horizontal	Vertical																					
Front	A	A																							
Right	A	A																							
Rear	A	A																							
Left	A	A																							
Test Equipment : 1. Signal Generator: N5181A (Agilent) 2. Power Amplifier: 80RF1000-175 (MILMEGA) & AS1860-50 (MILMEGA) 3. Log.-Per. Antenna: VULP 9118E (SCHWARZBECK) 4. RF Power Meter. Dual Channel: 4232A (BOONTON) 5. Field Strength Meter: RSS1006A (DARE)																									

11. ELECTRICAL FAST TRANSIENT/BURST IMMUNITY TEST

11.1. Block Diagram of Test Setup

11.1.1. Block Diagram of the EUT

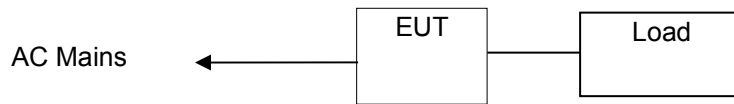

(EUT: Uninterruptible Power System)

11.1.2. EFT Test Setup

AC Port:

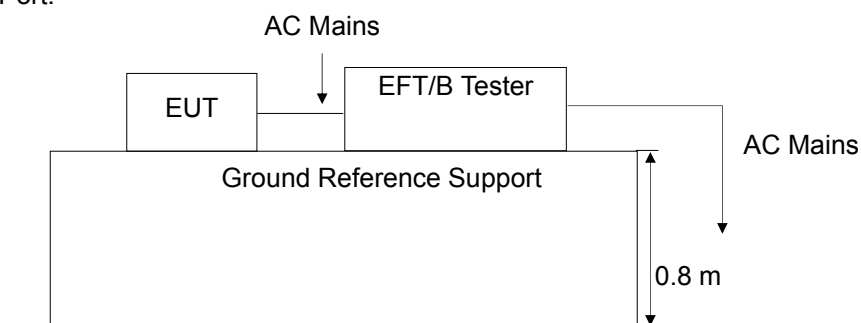

(EUT: Uninterruptible Power System)

11.2. Test Standard

IEC 61000-4-4:2012 (Level 3: 2kV/5kHz for AC mains)

11.3. Severity Levels and Performance Criterion

11.3.1. Severity level

Open Circuit Output Test Voltage $\pm 10\%$		
Level	On Power Supply Lines	On I/O (Input/Output) Signal data and control lines
1	0.5 kV	0.25 kV
2	1 kV	0.5 kV
3	2 kV	1 kV
4	4 kV	2 kV
X	Special	Special

11.3.2.Performance criterion: B

Performance criteria for immunity tests

	Criterion A	Criterion B
Output characteristics	Voltage permitted to vary only within the steady-state characteristics applicable (100 m sec limits in Figures 1, 2 or 3 of IEC 62040-3)	Voltage permitted to vary within the inverse time characteristics applicable (<100 m sec limits in Figures 1, 2 or 3 of IEC 62040-3)
External and internal indications and metering	Change only during test	Change only during test
Control signals to external devices	No change	Change only temporarily in consistency with the actual UPS mode of operation
Mode of operation	No change	Change only temporarily

11.4.EUT Configuration

The configurations of EUT are listed in Section 4.3.

11.5.Operating Condition of EUT

11.5.1.Setup the EUT as shown in Section 11.1.

11.5.2.Turn on the power of all equipments.

11.5.3.Let the EUT work in test mode (Line mode, Bat mode) and measure it.

11.6.Test Procedure

The EUT is put on the table which is 0.8 meter high above the ground. This reference ground plane shall project beyond the EUT by at least 0.1m on all sides and the minimum distance between EUT and all other conductive structure, except the ground plane beneath the EUT, shall be more than 0.5m.

11.6.1.For input and output AC power ports:

The EUT is connected to the power mains by using a coupling device which couples the EFT interference signal to AC power lines. Both polarities of the test voltage should be applied during compliance test and the duration of the test is 2 mins.

11.6.2.For signal lines and control lines ports:

It's unnecessary to test.

11.6.3.For DC output line ports:

It's unnecessary to test.

11.7.Test Result

PASS.

Please refer to the following page.

Electrical Fast Transient/Burst Test Results

EMTEK(SHENZHEN) CO., LTD.

Standard: IEC 61000-4-4		Result: <input checked="" type="checkbox"/> PASS / <input type="checkbox"/> FAIL	
Applicant : <u>INVT POWER SYSTEM (SHENZHEN) CO., LTD.</u>			
EUT : <u>Uninterruptible Power System</u>			
M/N : <u>HR1103S</u>			
Input Voltage: <u>AC 230V/50Hz</u>			
Criterion : <u>B</u>			
Ambient Condition : <u>23 °C</u>		<u>55% RH</u>	
Operation Mode: Line mode, Bat mode			
Line : <input checked="" type="checkbox"/> AC Mains		Line : <input type="checkbox"/> Signal <input type="checkbox"/> I/O Cable	
Coupling : <input checked="" type="checkbox"/> Direct		Coupling : <input type="checkbox"/> Capacitive	
Test Time : 120s			
Line	Test Voltage	Result(+)	Result(-)
AC input power ports:			
L	2kV	A	A
N	2KV	A	A
PE	2KV	A	A
L、N	2KV	A	A
L、PE	2KV	A	A
N、PE	2KV	A	A
L、N、PE	2KV	A	A
AC output power ports: L	2kV	A	A
N	2kV	A	A
PE	2kV	A	A
L、N	2kV	A	A
L、PE	2kV	A	A
N、PE	2kV	A	A
L、N、PE	2kV	A	A
Test Equipment: Burst Tester Model : PEFT 4010			

12. SURGE IMMUNITY TEST

12.1. Block Diagram of Test Setup

12.1.1. Block Diagram of the EUT



(EUT: Uninterruptible Power System)

12.1.2. Surge Test Setup

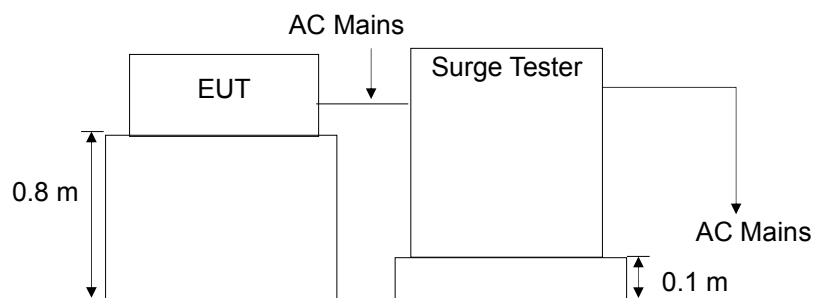

(EUT: Uninterruptible Power System)

12.2. Test Standard

IEC 61000-4-5:2014 (Line to Line: Level 2, 1.0kV, Line to earth: Level 3, 2.0kV)

12.3. Severity Levels and Performance Criterion

12.3.1. Severity level

Severity Level	Open-Circuit Test Voltage(kV)
1	0.5
2	1.0
3	2.0
4	4.0
*	Special

12.3.2. Performance criterion: B

Performance criteria for immunity tests

	Criterion A	Criterion B
Output characteristics	Voltage permitted to vary only within the steady-state characteristics applicable (100 m sec limits in Figures 1, 2 or 3 of IEC 62040-3)	Voltage permitted to vary within the inverse time characteristics applicable (<100 m sec limits in Figures 1, 2 or 3 of IEC 62040-3)
External and internal indications and metering	Change only during test	Change only during test
Control signals to external devices	No change	Change only temporarily in consistency with the actual UPS mode of operation
Mode of operation	No change	Change only temporarily

12.4.EUT Configuration

The configurations of EUT are listed in Section 4.3.

12.5.Operating Condition of EUT

12.5.1.Setup the EUT as shown in Section 12.1.

12.5.2.Turn on the power of all equipments.

12.5.3.Let the EUT work in test mode (Line mode) and measure it.

12.6.Test Procedure

- 1) Set up the EUT and test generator as shown on Section 12.1.2.
For line to line coupling mode, provide a 1.0 kV 1.2/50us voltage surge
For line to earth coupling mode, provide a 2.0 kV 1.2/50us voltage surge.
(at open-circuit condition) and 8/20us current surge to EUT selected points.
- 2) At least 5 positive and 5 negative (polarity) tests with a maximum 1/min repetition rate are conducted during test.
- 3) Different phase angles are done individually.
- 4) Record the EUT operating situation during compliance test and decide the EUT immunity criterion for above each test.

12.7.Test Result

PASS.

Please refer to the following page.

Surge Immunity Test Result

EMTEK(SHENZHEN) CO., LTD.

Applicant: <u>INVT POWER SYSTEM (SHENZHEN) CO., LTD.</u> EUT : <u>Uninterruptible Power System</u> M/N : <u>HR1103S</u> Power Supply: <u>AC 230V / 50Hz</u> Test Engineer: <u>DK</u>				Test Date : <u>January 13, 2014</u> Temperature : <u>23°C</u> Humidity : <u>51%</u> Test Mode : <u>Line mode</u> Criterion : <u>B</u>	
Location	Polarity	Phase Angle	Number of Pulse	Pulse Voltage (kV)	Result
AC Input: L-N	+	0°, 90°, 180°, 270°	5	1.0	A
	-	0°, 90°, 180°, 270°	5	1.0	A
L-PE	+	0°, 90°, 180°, 270°	5	2.0	A
	-	0°, 90°, 180°, 270°	5	2.0	A
N-PE	+	0°, 90°, 180°, 270°	5	2.0	A
	-	0°, 90°, 180°, 270°	5	2.0	A
AC Output: L-N	+	Random	5	1.0	A
	-	Random	5	1.0	A
L-PE	+	Random	5	2.0	A
	-	Random	5	2.0	A
N-PE	+	Random	5	2.0	A
	-	Random	5	2.0	A

13. INJECTED CURRENTS SUSCEPTIBILITY TEST

13.1. Block Diagram of Test Setup

13.1.1. Block Diagram of the EUT



(EUT: Uninterruptible Power System)

13.1.2. Block Diagram of Test Setup

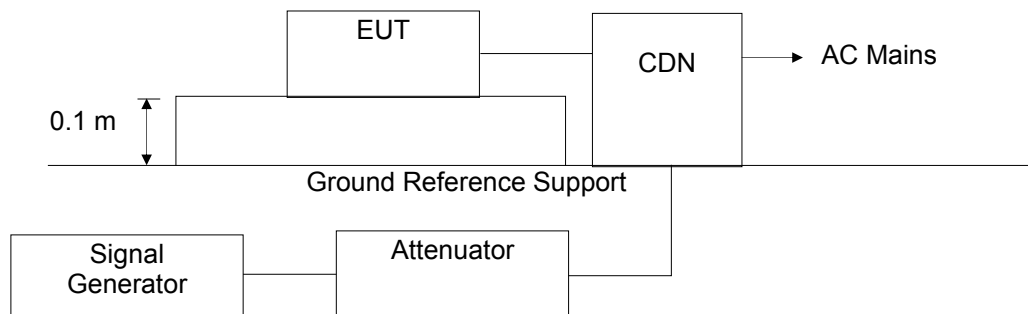

(EUT: Uninterruptible Power System)

13.2. Test Standard

IEC 61000-4-6:2013 (Level 3: 10V (rms), (0.15MHz ~ 80MHz))

13.3. Severity Levels and Performance Criterion

13.3.1. Severity level

Level	Field Strength (V)
1	1
2	3
3	10
X	Special

13.3.2.Performance criterion: A

Performance criteria for immunity tests

	Criterion A	Criterion B
Output characteristics	Voltage permitted to vary only within the steady-state characteristics applicable (100 m sec limits in Figures 1, 2 or 3 of IEC 62040-3)	Voltage permitted to vary within the inverse time characteristics applicable (<100 m sec limits in Figures 1, 2 or 3 of IEC 62040-3)
External and internal indications and metering	Change only during test	Change only during test
Control signals to external devices	No change	Change only temporarily in consistency with the actual UPS mode of operation
Mode of operation	No change	Change only temporarily

13.4.EUT Configuration

The configurations of EUT are listed in Section 4.3.

13.5.Operating Condition of EUT

13.5.1.Setup the EUT as shown in Section 13.1.

13.5.2.Turn on the power of all equipments.

13.5.3.Let the EUT work in test mode (Line mode) and measure it.

13.6.Test Procedure

- 1) Set up the EUT, CDN and test generators as shown on Section 13.1.2.
- 2) Let the EUT work in test mode and measure it.
- 3) The EUT are placed on an insulating support 0.1m high above a ground reference plane. CDN (coupling and decoupling device) is placed on the ground plane about 0.3m from EUT. Cables between CDN and EUT are as short as possible, and their height above the ground reference plane shall be between 30 and 50 mm (where possible).
- 4) The disturbance signal described below is injected to EUT through CDN.
- 5) The EUT operates within its operational mode(s) under intended climatic conditions after power on.
- 6) The frequency range is swept from 150kHz to 80MHz using 10V signal level, and with the disturbance signal 80% amplitude modulated with a 1kHz sine wave.
- 7) The rate of sweep shall not exceed $1.5 \cdot 10^{-3}$ decades/s. Where the frequency is swept incrementally, the step size shall not exceed 1% of the start and thereafter 1% of the preceding frequency value.
- 8) Recording the EUT operating situation during compliance testing and decide the EUT immunity criterion.

13.7.Test Results

PASS.

Please refer to the following page.

Injected Currents Susceptibility Test Results

EMTEK(SHENZHEN) CO., LTD.

Applicant : <u>INVT POWER SYSTEM (SHENZHEN) CO., LTD.</u> EUT : <u>Uninterruptible Power System</u> M/N : <u>HR1103S</u> Power Supply : <u>AC 230V/50Hz</u> Test Engineer : <u>HE</u>			Test Date: <u>January 13, 2014</u> Temperature : <u>23°C</u> Humidity : <u>50%</u>	
Test Mode : <u>Line mode</u>				
Frequency Range (MHz)	Injected Position	Strength (Unmodulated)	Criterion	Result
0.15 ~ 80	AC Input	10V	A	A
0.15 ~ 80	AC Output	10V	A	A
Remark : 1. Modulation Signal:1kHz 80% AM Measurement Equipment : Simulator: CWS 500 (SWITZERLAND EMTEST) CDN : <input type="checkbox"/> CDN-M2 (SWITZERLAND EMTEST) <input checked="" type="checkbox"/> CDN-M3 (SWITZERLAND EMTEST) <input type="checkbox"/> Injection Clamp (EMTEST F-2031-23MM)				

14. MAGNETIC FIELD SUSCEPTIBILITY TEST

14.1. Block Diagram of Test Setup

14.1.1. Block diagram of test setup



(EUT: Uninterruptible Power System)

14.1.2. Magnetic field test setup

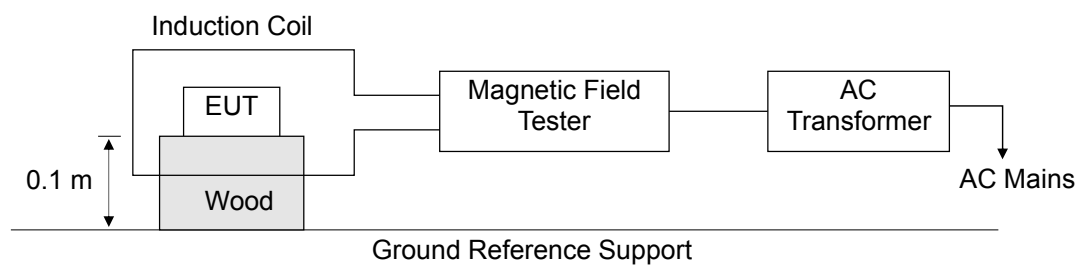

(EUT: Uninterruptible Power System)

14.2. Test Standard

IEC 61000-4-8:2009 (Severity Level 4: 30A/m)

14.3. Severity Levels and Performance Criterion

14.3.1. Severity Levels

Level	Field Strength A/m
1	1
2	3
3	10
4	30
5	100
X	Special

14.3.2.Performance Criterion: A

Performance criteria for immunity tests

	Criterion A	Criterion B
Output characteristics	Voltage permitted to vary only within the steady-state characteristics applicable (100 m sec limits in Figures 1, 2 or 3 of IEC 62040-3)	Voltage permitted to vary within the inverse time characteristics applicable (<100 m sec limits in Figures 1, 2 or 3 of IEC 62040-3)
External and internal indications and metering	Change only during test	Change only during test
Control signals to external devices	No change	Change only temporarily in consistency with the actual UPS mode of operation
Mode of operation	No change	Change only temporarily

14.4.EUT Configuration on Test

The configuration of the EUT is same as Section 4.3.

14.5.Test Procedure

The EUT is placed in the middle of a induction coil (1*1m), under which is a 1*1*0.1m (high) table, this small table is also placed on a larger table, 0.8 m above the ground. Both horizontal and vertical polarization of the induction coil is set on test, so that each side of the EUT is affected by the magnetic field. Also can reach the same aim by change the position of the EUT.

14.6.Test Results

PASS.

Please refer to the following page.

Magnetic Field Immunity Test Result

EMTEK(SHENZHEN) CO., LTD.

Standard: IEC 61000-4-8	Result: <input checked="" type="checkbox"/> Pass / <input type="checkbox"/> Fail			
<p>Applicant : <u>INVT POWER SYSTEM (SHENZHEN) CO., LTD.</u></p> <p>EUT : <u>Uninterruptible Power System</u> M/N: <u>HR1103S</u></p> <p>Input Voltage : <u>230V</u> / <u>50Hz</u></p> <p>Date of Test : <u>January 13, 2014</u> Test Engineer: <u>HE</u></p> <p>Ambient Condition : Temp : <u>22°C</u> Humid: <u>50%</u></p> <p>Criterion : A</p>				
Operation Mode : <u>Line mode, Bat mode</u>				
Test Level (A/m)	Testing Duration	Coil Orientation	Criterion	Result
30	5 mins	X	A	A
30	5 mins	Y	A	A
30	5 mins	Z	A	A
Test Equipment : Magnetic Field Test : HEAFELY MAG 100.1				

15. VOLTAGE DIPS AND INTERRUPTIONS TEST

15.1. Block Diagram of Test Setup

15.1.1. Block Diagram of the EUT

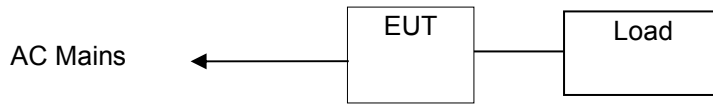

(EUT: Uninterruptible Power System)

15.1.2. Dips Test Setup

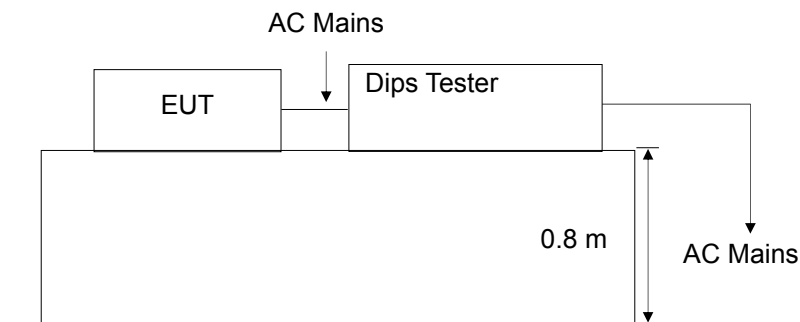

(EUT: Uninterruptible Power System)

15.2. Test Standard

IEC 61000-4-11:2004

15.3. Severity Levels and Performance Criterion

15.3.1. Severity level

Test Level %UT	Voltage dip and short interruptions %UT	Duration (in period)
0	100	0.5
70	30	1
		5
		10
		25
0	100	50
		*

15.3.2.Performance criterion: B

Performance criteria for immunity tests

	Criterion A	Criterion B
Output characteristics	Voltage permitted to vary only within the steady-state characteristics applicable (100 m sec limits in Figures 1, 2 or 3 of IEC 62040-3)	Voltage permitted to vary within the inverse time characteristics applicable (<100 m sec limits in Figures 1, 2 or 3 of IEC 62040-3)
External and internal indications and metering	Change only during test	Change only during test
Control signals to external devices	No change	Change only temporarily in consistency with the actual UPS mode of operation
Mode of operation	No change	Change only temporarily

15.4.EUT Configuration

The configurations of EUT are listed in Section 4.3.

15.5.Operating Condition of EUT

15.5.1.Setup the EUT as shown in Section 15.1.

15.5.2.Turn on the power of all equipments.

15.5.3.Let the EUT work in test mode (Line mode) and measure it.

15.6.Test Procedure

15.6.1.Set up the EUT and test generator as shown on Section 15.1.2.

15.6.2.The interruption is introduced at selected phase angles with specified duration.

15.6.3.Record any degradation of performance.

15.7.Test Result

PASS.

Please refer to the following page.

Voltage Dips and Interruptions Test Results

EMTEK(SHENZHEN) CO., LTD.

Applicant: <u>INVT POWER SYSTEM (SHENZHEN) CO., LTD.</u> EUT : <u>Uninterruptible Power System</u> M/N : <u>HR1103S</u> Power Supply : <u>AC230V/50Hz</u>		Test Date : <u>January 13, 2014</u> Temperature : <u>22°C</u> Humidity : <u>50%</u> Test Engineer : <u>HE</u>		
Test Mode: <u>Line mode</u>				
Test Level % U _T	Voltage Dips & Short Interruptions % U _T	Duration (in periods)	Criterion <input checked="" type="checkbox"/> A <input type="checkbox"/> B <input type="checkbox"/> C <input type="checkbox"/> D	Result
0	100	0.5P	B	A
0	100	1P	B	A
70	30	25P	B	A
0	100	250P	B	A
Test Equipment : HEAFELY: Pline1610				

16. LOW FREQUENCY SIGNALS TEST

16.1. Block Diagram of Test Setup

16.1.1. Block Diagram of the EUT

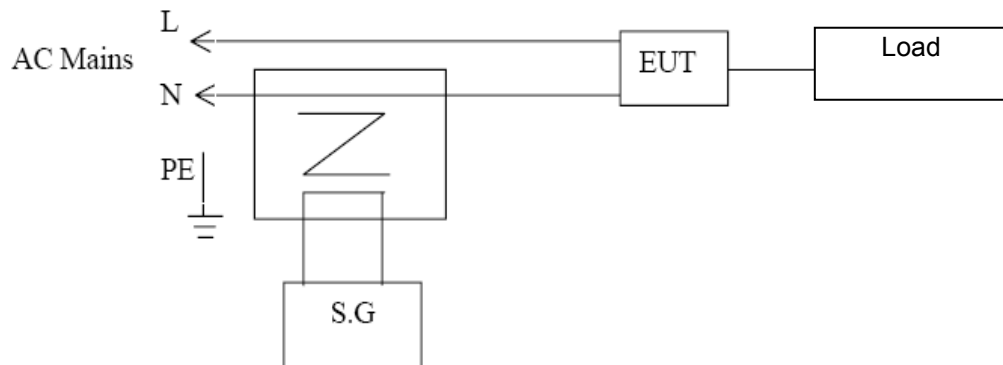

(EUT: Uninterruptible Power System)

16.1.2. Block Diagram of Test Setup

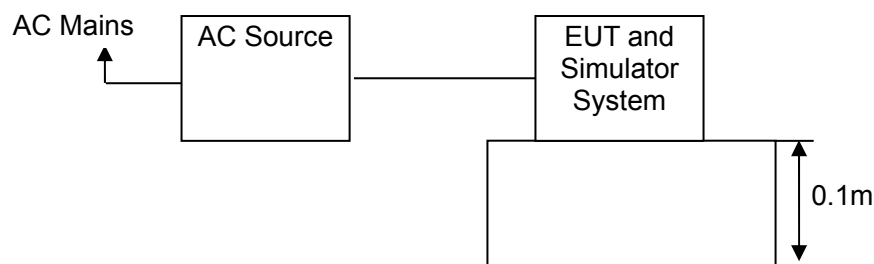

(EUT: Uninterruptible Power System)

16.2. Test Standard

EN 61000-2-2:2002, Performance: A

16.3. Operating Condition of EUT

Same as Section 4.5, Except the test setup replaced by Section 16.1.

16.4. Test Results

PASS.

Please refer to following page.

Low Frequency Signals Test Result

EMTEK(SHENZHEN) CO., LTD.

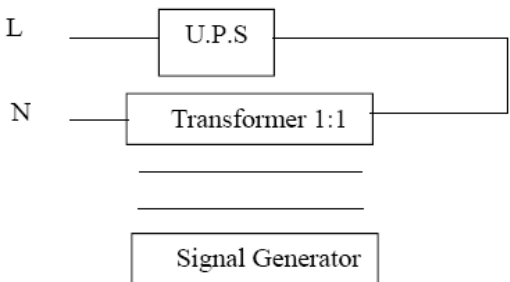
Applicant : <u>INVT POWER SYSTEM (SHENZHEN) CO., LTD.</u> EUT : <u>Uninterruptible Power System</u> M/N : <u>HR1103S</u> Power Supply : <u>AC 230V/50Hz</u> Test Engineer : <u>HE</u>			Test Date: <u>January 13, 2014</u> Temperature : <u>23°C</u> Humidity : <u>51%</u> Test Mode : <u>Line mode, Bat mode</u>	
Frequency Range (Hz)	Position	Strength	Result	Note
140	See Fig.1	10V(rms) Sinusoidal	A	N/A
160			A	
200			A	
240			A	
280			A	
320			A	
360			A	
Note: 			Test Equipment: 1. Isolation transformer Primary: Secondary=1:1 2. Signal Generator AC Source: 65930 (Chroma)	

17. TEST PHOTOGRAPHS

17.1. Photo of Conducted Emission Measurement



17.2.Photo of Radiation Emission Measurement

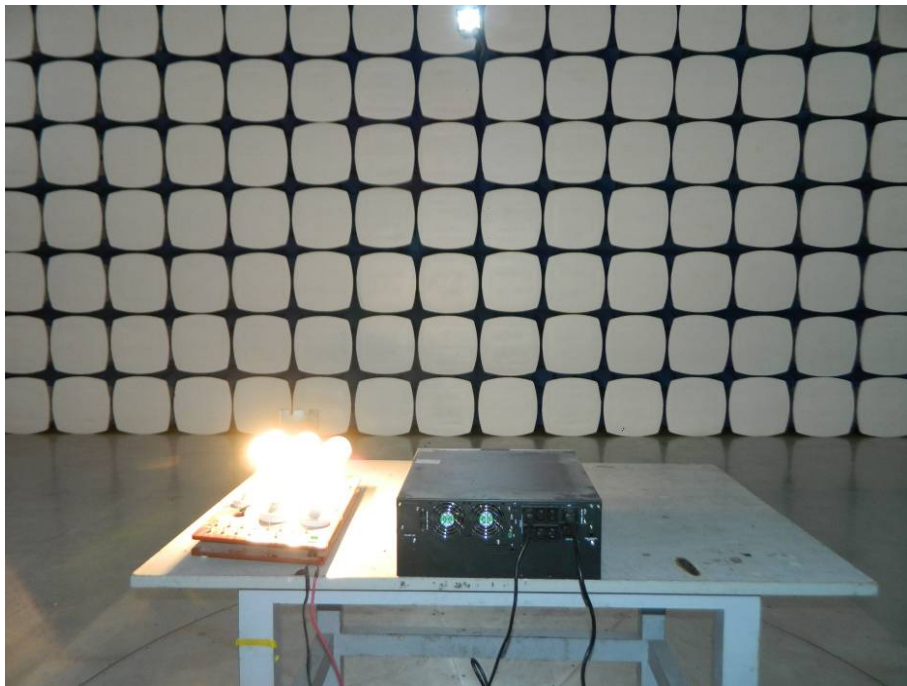
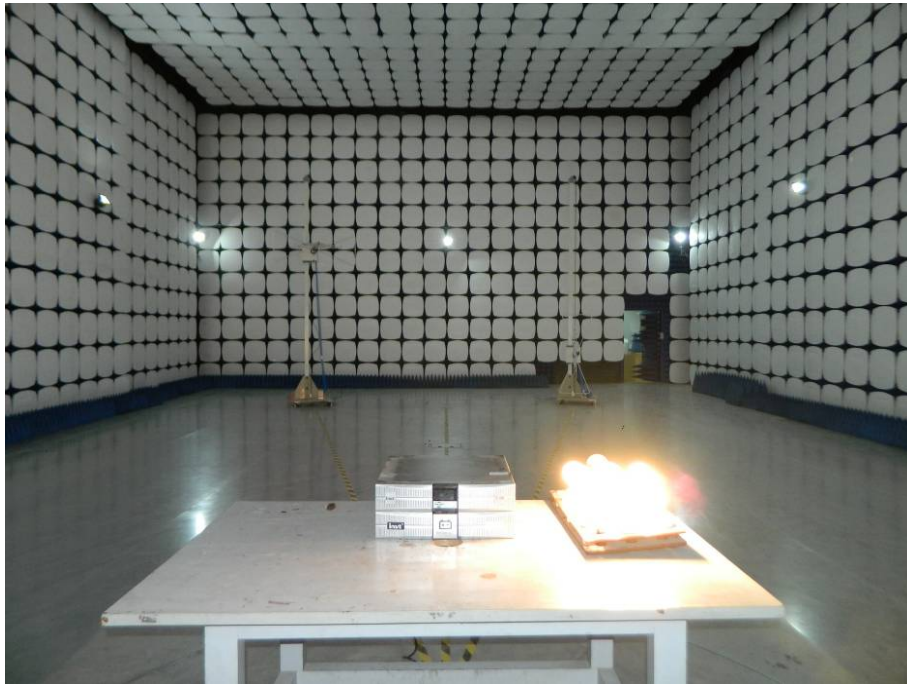

17.3.Photo of Harmonic / Flick Measurement



17.4.Photo of Electrostatic Discharge Test



17.5. Photo of RF Field Strength Susceptibility Test

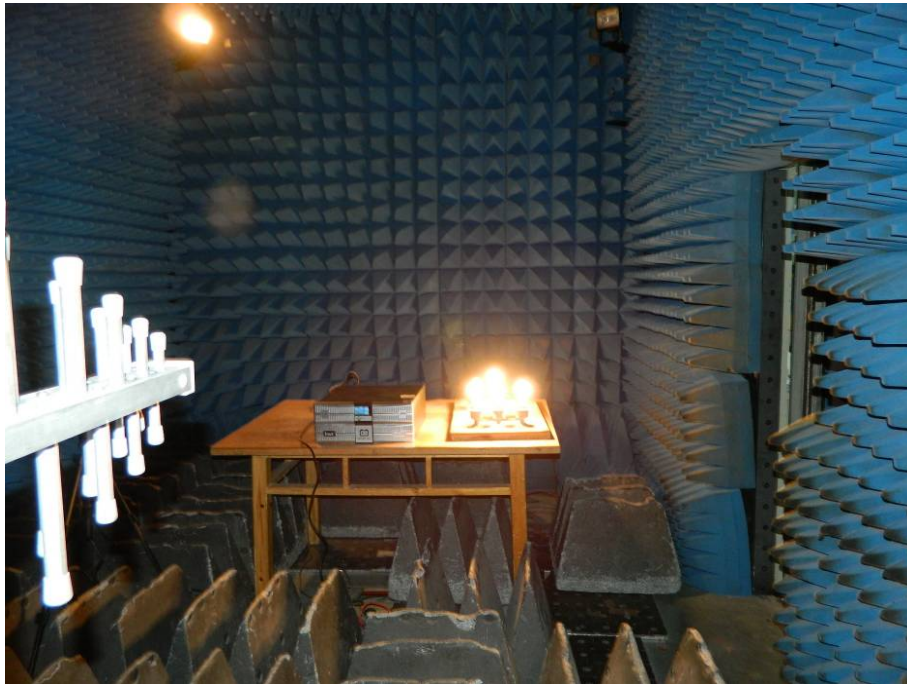

17.6. Photo of Electrical Fast Transient / Burst Test

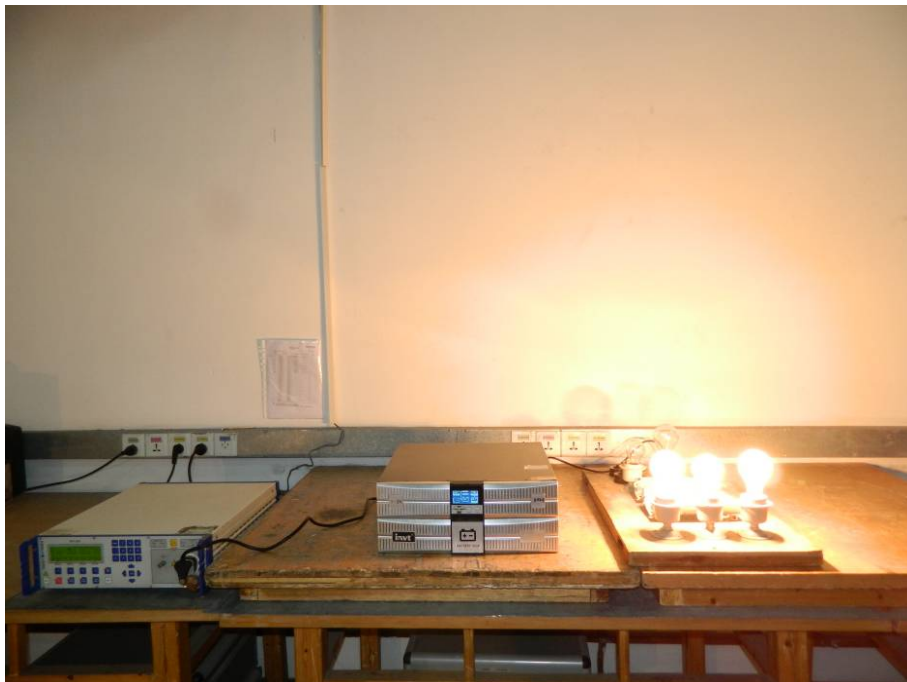

17.7.Photo of Surge Test



17.8.Photo of Injected Currents Susceptibility Test



17.9.Photo of Magnetic Field Immunity Test



17.10.Photo of Voltage Dips and Interruptions Test



17.11.Photo of Low Frequency Signals Test



APPENDIX (PHOTOS OF EUT)



