

SUPER[®]

SC826 Chassis Series

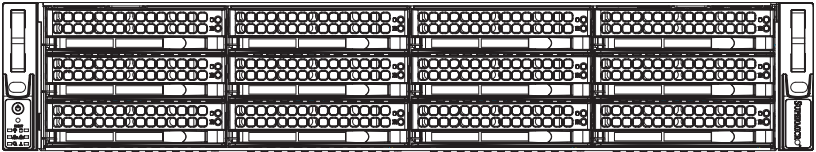

SC826TQ-R800UB

SC826E1-R800UB

SC826TQ-R800LP

SC826E2-R800LP

SC826E1-R800LP

SC826E2-R800UB

SC826TQ-R800RC2
(OEM)

SC826E2-R800RC2
(OEM)

SC826E1-R800RC2
(OEM)

USER'S MANUAL

1.0c

The information in this User's Manual has been carefully reviewed and is believed to be accurate. The vendor assumes no responsibility for any inaccuracies that may be contained in this document, makes no commitment to update or to keep current the information in this manual, or to notify any person or organization of the updates. **Please Note: For the most up-to-date version of this manual, please see our web site at www.supermicro.com.**

Super Micro Computer, Inc. ("Supermicro") reserves the right to make changes to the product described in this manual at any time and without notice. This product, including software, if any, and documentation may not, in whole or in part, be copied, photocopied, reproduced, translated or reduced to any medium or machine without prior written consent.

IN NO EVENT WILL SUPERMICRO BE LIABLE FOR DIRECT, INDIRECT, SPECIAL, INCIDENTAL, SPECULATIVE OR CONSEQUENTIAL DAMAGES ARISING FROM THE USE OR INABILITY TO USE THIS PRODUCT OR DOCUMENTATION, EVEN IF ADVISED OF THE POSSIBILITY OF SUCH DAMAGES. IN PARTICULAR, SUPERMICRO SHALL NOT HAVE LIABILITY FOR ANY HARDWARE, SOFTWARE, OR DATA STORED OR USED WITH THE PRODUCT, INCLUDING THE COSTS OF REPAIRING, REPLACING, INTEGRATING, INSTALLING OR RECOVERING SUCH HARDWARE, SOFTWARE, OR DATA.

Any disputes arising between manufacturer and customer shall be governed by the laws of Santa Clara County in the State of California, USA. The State of California, County of Santa Clara shall be the exclusive venue for the resolution of any such disputes. Super Micro's total liability for all claims will not exceed the price paid for the hardware product.

FCC Statement: This equipment has been tested and found to comply with the limits for a Class A digital device pursuant to Part 15 of the FCC Rules. These limits are designed to provide reasonable protection against harmful interference when the equipment is operated in a commercial environment. This equipment generates, uses, and can radiate radio frequency energy and, if not installed and used in accordance with the manufacturer's instruction manual, may cause harmful interference with radio communications. Operation of this equipment in a residential area is likely to cause harmful interference, in which case you will be required to correct the interference at your own expense.

California Best Management Practices Regulations for Perchlorate Materials: This Perchlorate warning applies only to products containing CR (Manganese Dioxide) Lithium coin cells. "Perchlorate Material-special handling may apply. See www.dtsc.ca.gov/hazardouswaste/perchlorate"

WARNING: Handling of lead solder materials used in this product may expose you to lead, a chemical known to the State of California to cause birth defects and other reproductive harm.

Manual Revision 1.0c

Release Date: May 5, 2008

Unless you request and receive written permission from Super Micro Computer, Inc., you may not copy any part of this document.

Information in this document is subject to change without notice. Other products and companies referred to herein are trademarks or registered trademarks of their respective companies or mark holders.

Copyright © 2008 by Super Micro Computer, Inc.

All rights reserved.

Printed in the United States of America

Preface

This manual is written for professional system integrators and PC technicians. It provides information for the installation and use of the SC826 chassis. Installation and maintenance should be performed by experienced technicians only.

Supermicro's SC826 chassis features a unique design, which is highly optimized for data storage applications. It is equipped with an 800W (redundant) high-efficiency power supply for superb power savings. High-performance fans provide ample cooling for the chassis.

This document lists compatible parts and configurations available when this document was published. Always refer to our Web site for updates on supported parts and configurations.

Manual Organization

Chapter 1: Introduction

The introduction provides a checklist of the main components included with this chassis and describes the main features of the SC826 chassis. This chapter also includes contact information.

Chapter 2: System Safety

This chapter lists warnings, precautions, and system safety. You should thoroughly familiarize yourself with this chapter for a general overview of safety precautions that should be followed before installing and servicing this chassis.

Chapter 3: Chassis Components

Refer here for details on this chassis model including the fans, bays, airflow shields, and other components.

Chapter 4: System Interface

Refer to this chapter for details on the system interface, which includes the functions and information provided by the control panel on the chassis as well as other LEDs located throughout the system.

Chapter 5: Chassis Setup and Maintenance

Refer to this chapter for detailed information on this chassis. You should follow the procedures given in this chapter when installing, removing, or reconfiguring your chassis.

Chapter 6: Rack Installation

Refer to this chapter for detailed information on chassis rack installation. You should follow the procedures given in this chapter when installing, removing or reconfiguring your chassis into a rack environment.

Appendix A:

This section references cables, which are compatible with your SC826 system. Refer to our Web site for additional information on cabling at www.supermicro.com.

Appendix B:

This chapter lists supported power supply information for your SC826 system. Refer to our Web site for additional details at www.supermicro.com.

Appendix C:

This section provides detailed information on the BPN-SAS-826TQ backplane. Additional information can be found on our Web site at www.supermicro.com

Appendix D:

This section provides detailed information on the BPN-SAS-826EL series backplanes. Additional information can be found on our Web site at www.supermicro.com

Table of Contents

Chapter 1 Introduction

1-1	Overview	1-1
1-2	Shipping List.....	1-1
1-3	Contacting Supermicro.....	1-2
1-4	Returning Merchandise for Service	1-3

Chapter 2 System Safety

2-1	Overview	2-1
2-2	Warnings and Precautions	2-1
2-3	Preparing for Setup.....	2-1
2-4	Electrical Safety Precautions	2-2
2-5	General Safety Precautions	2-3
2-6	System Safety	2-3

Chapter 3 System Interface

3-1	Overview	3-1
3-2	Control Panel Buttons	3-2
3-3	Control Panel LEDs	3-2
3-4	Drive Carrier LEDs.....	3-4

Chapter 4 Chassis Setup and Maintenance

4-1	Overview	4-1
4-2	Installation Steps.....	4-1
4-3	Removing the Chassis Cover	4-2
4-4	Installing Hard Drives.....	4-3
4-5	Installing the Motherboard	4-6
	Riser Card Bracket (OEM ONLY)	4-6
	I/O Shield	4-7
	Permanent and Optional Standoffs.....	4-8
	Installing the Motherboard	4-9
	Add-on Card Setup (SC826 RC chassis - OEM Only).....	4-10
	Add-on Card Setup (SC826 LP Chassis)	4-12
4-6	Installing the Air Shroud.....	4-13
4-7	Checking the Air Flow	4-14
	Installation Complete.....	4-15
4-8	System Fans	4-16
4-9	Power Supply	4-18
4-10	Optional Front Bezel	4-20

Chapter 5 Rack Installation

5-1	Overview	5-1
5-2	Unpacking the System	5-1
5-3	Preparing for Setup	5-1
	Choosing a Setup Location	5-1
	Rack Precautions	5-2
	General Server Precautions	5-2
	Rack Mounting Considerations	5-3
	Ambient Operating Temperature	5-3
	Reduced Airflow	5-3
	Mechanical Loading	5-3
	Circuit Overloading	5-3
	Reliable Ground	5-3
	Identifying the Sections of the Rack Rails	5-4
	Locking Tabs	5-4
	Outer Rack Rails	5-6

Appendix A SC826 Chassis Cables**Appendix B SC826 Power Supply Specifications****Appendix C BPN-SAS 826TQ Backplane Specifications****Appendix D BPN-SAS-826EL Backplane Specifications**

Chapter 1

Introduction

1-1 Overview

Supermicro's SC826 2U chassis features a unique and highly-optimized design. The chassis is equipped with high efficiency power supply.

1-2 Shipping List

Please visit the following link for the latest shipping lists and part numbers for your particular chassis model <http://www.supermicro.com/products/chassis/1U/?chs=826>

Model	CPU	HDD	I/O Slots	Power Supply
SC826TQ-R800UB	DP Dual-core Xeon	12x SAS / SATA w/SES2	4 FF + 3 LP	800W Redundant
SC826E2-R800UB	DP Dual-core Xeon	12x SAS / SATA w/SES2	4 FF + 3 LP	800W Redundant
SC826E1-R800UB	DP Dual-core Xeon	12x SAS / SATA w/SES2	4 FF + 3 LP	800W Redundant
SC826TQ-R800LP	DP Dual-core Xeon	12x SAS / SATA w/SES2	7x LP	800W Redundant
SC826E2-R800LP	DP Dual-core Xeon	12x SAS / SATA w/SES2	7x LP	800W Redundant
SC826E1-R800LP	DP Dual-core Xeon	12x SAS / SATA w/SES2	7x LP	800W Redundant
SC826TQ-R800RC2	DP Dual-core Xeon	12x SAS / SATA w/SES2	3 FF + 3 LP	800W Redundant
SC826E2-R800RC2	DP Dual-core Xeon	12x SAS / SATA w/SES2	3 FF + 3 LP	560W
SC826E1-R800RC2	DP Dual-core Xeon	12x SAS / SATA w/SES2	3 FF + 3 LP	800W Redundant

1-3 Contacting Supermicro

Headquarters

Address: Super Micro Computer, Inc.
980 Rock Ave.
San Jose, CA 95131 U.S.A.

Tel: +1 (408) 503-8000

Fax: +1 (408) 503-8008

Email: marketing@supermicro.com (General Information)
support@supermicro.com (Technical Support)

Web Site: www.supermicro.com

Europe

Address: Super Micro Computer B.V.
Het Sterrenbeeld 28, 5215 ML
's-Hertogenbosch, The Netherlands

Tel: +31 (0) 73-6400390

Fax: +31 (0) 73-6416525

Email: sales@supermicro.nl (General Information)
support@supermicro.nl (Technical Support)
rma@supermicro.nl (Customer Support)

Asia-Pacific

Address: Super Micro Computer, Inc.
4F, No. 232-1, Liancheng Rd.
Chung-Ho 235, Taipei County
Taiwan, R.O.C.

Tel: +886-(2) 8226-3990

Fax: +886-(2) 8226-3991

Web Site: www.supermicro.com.tw

Technical Support:

Email: support@supermicro.com.tw

Tel: 886-2-8226-1900

1-4 Returning Merchandise for Service

A receipt or copy of your invoice marked with the date of purchase is required before any warranty service will be rendered. You can obtain service by calling your vendor for a Returned Merchandise Authorization (RMA) number. When returning to the manufacturer, the RMA number should be prominently displayed on the outside of the shipping carton, and mailed prepaid or hand-carried. Shipping and handling charges will be applied for all orders that must be mailed when service is complete.

For faster service, RMA authorizations may be requested online (<http://www.supermicro.com/support/rma/>).

Whenever possible, repack the chassis in the original Supermicro carton, using the original packaging material. If these are no longer available, be sure to pack the chassis securely, using packaging material to surround the chassis so that it does not shift within the carton and become damaged during shipping.

This warranty only covers normal consumer use and does not cover damages incurred in shipping or from failure due to the alteration, misuse, abuse or improper maintenance of products.

During the warranty period, contact your distributor first for any product problems.

Chapter 2

System Safety

2-1 Overview

This chapter provides a quick setup checklist to get your chassis up and running. Following the steps in order given should enable you to have your chassis setup and operational within a minimal amount of time. This quick set up assumes that you are an experienced technician, familiar with common concepts and terminology.

2-2 Warnings and Precautions

You should inspect the box the chassis was shipped in and note if it was damaged in any way. If the chassis itself shows damage, file a damage claim with carrier who delivered your system.

Decide on a suitable location for the rack unit that will hold that chassis. It should be situated in a clean, dust-free area that is well ventilated. Avoid areas where heat, electrical noise and electromagnetic fields are generated.

You will also need it placed near at least one grounded power outlet. When configured, the SC826 chassis includes one power supply. "R" models (i.e. SC826S-R700V Chassis) include a redundant power supply and require two grounded outlets.

2-3 Preparing for Setup

The SC826 Chassis includes a set of rail assemblies, including mounting brackets and mounting screws you will need to install the systems into the rack. Please read this manual in its entirety before you begin the installation procedure.

2-4 Electrical Safety Precautions

Basic electrical safety precautions should be followed to protect yourself from harm and the SC826 from damage:

- Be aware of the locations of the power on/off switch on the chassis as well as the room's emergency power-off switch, disconnection switch or electrical outlet. If an electrical accident occurs, you can then quickly remove power from the system.
- Do not work alone when working with high voltage components.
- Power should always be disconnected from the system when removing or installing main system components, such as the serverboard, memory modules and the DVD-ROM and floppy drives (not necessary for hot swappable drives). When disconnecting power, you should first power down the system with the operating system and then unplug the power cords from all the power supply modules in the system.
- When working around exposed electrical circuits, another person who is familiar with the power-off controls should be nearby to switch off the power, if necessary.
- Use only one hand when working with powered-on electrical equipment. This is to avoid making a complete circuit, which will cause electrical shock. Use extreme caution when using metal tools, which can easily damage any electrical components or circuit boards they come into contact with.
- Do not use mats designed to decrease electrostatic discharge as protection from electrical shock. Instead, use rubber mats that have been specifically designed as electrical insulators.
- The power supply power cord must include a grounding plug and must be plugged into grounded electrical outlets.
- Serverboard Battery: CAUTION - There is a danger of explosion if the onboard battery is installed upside down, which will reverse its polarities This battery must be replaced only with the same or an equivalent type recommended by the manufacturer. Dispose of used batteries according to the manufacturer's instructions.

- DVD-ROM Laser: CAUTION - this server may have come equipped with a DVD-ROM drive. To prevent direct exposure to the laser beam and hazardous radiation exposure, do not open the enclosure or use the unit in any unconventional way.

2-5 General Safety Precautions

- Keep the area around the chassis clean and free of clutter.
- Place the chassis top cover and any system components that have been removed away from the system or on a table so that they won't accidentally be stepped on.
- While working on the system, do not wear loose clothing such as neckties and unbuttoned shirt sleeves, which can come into contact with electrical circuits or be pulled into a cooling fan.
- Remove any jewelry or metal objects from your body, which are excellent metal conductors that can create short circuits and harm you if they come into contact with printed circuit boards or areas where power is present.
- After accessing the inside of the system, close the system back up and secure it to the rack unit with the retention screws after ensuring that all connections have been made.

2-6 System Safety

Electrostatic discharge (ESD) is generated by two objects with different electrical charges coming into contact with each other. An electrical discharge is created to neutralize this difference, which can damage electronic components and printed circuit boards. The following measures are generally sufficient to neutralize this difference before contact is made to protect your equipment from ESD:

- Do not use mats designed to decrease electrostatic discharge as protection from electrical shock. Instead, use rubber mats that have been specifically designed as electrical insulators.
- Use a grounded wrist strap designed to prevent static discharge.
- Keep all components and printed circuit boards (PCBs) in their antistatic bags until ready for use.

- Touch a grounded metal object before removing any board from its antistatic bag.
- Do not let components or PCBs come into contact with your clothing, which may retain a charge even if you are wearing a wrist strap.
- Handle a board by its edges only; do not touch its components, peripheral chips, memory modules or contacts.
- When handling chips or modules, avoid touching their pins.
- Put the serverboard and peripherals back into their antistatic bags when not in use.
- For grounding purposes, make sure your computer chassis provides excellent conductivity between the power supply, the case, the mounting fasteners and the serverboard.

Chapter 3

System Interface

3-1 Overview

There are several LEDs on the control panel as well as others on the drive carriers to keep you constantly informed of the overall status of the system as well as the activity and health of specific components. Most SC826 models are two buttons on the control panel: a reset button and an on/off switch. This chapter explains the meanings of all LED indicators and the appropriate response you may need to take.

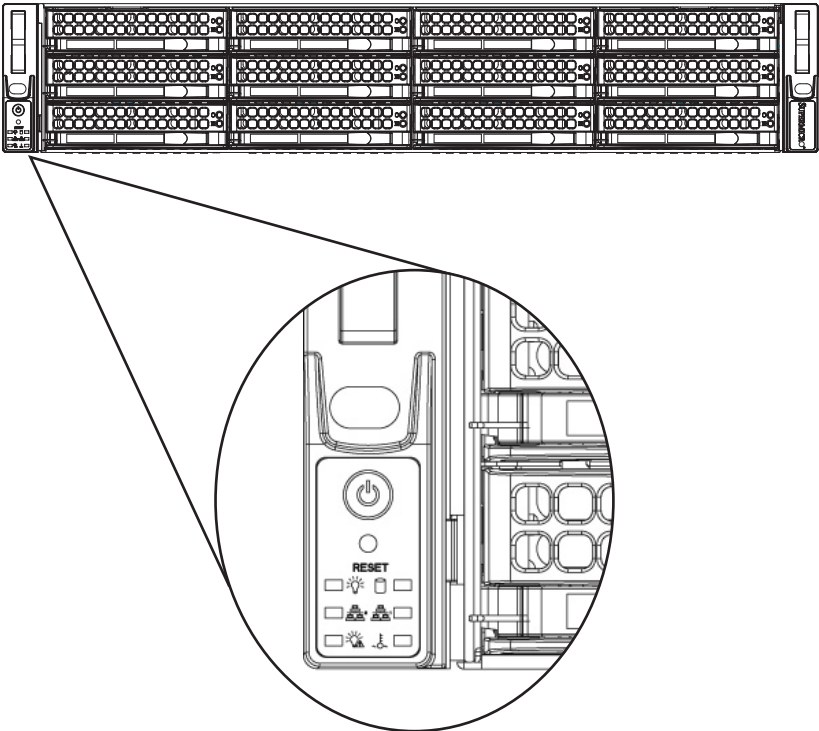
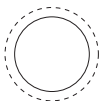

Figure 3-1: Chassis User Interface

3-2 Control Panel Buttons

There are two push-buttons located on the front of the chassis. These are (in order from left to right) a reset button and a power on/off button.



- **Reset:** The reset button is used to reboot the system.



- **Power:** The main power switch is used to apply or remove power from the power supply to the server system. Turning off system power with this button removes the main power but keeps standby power supplied to the system. Therefore, you must unplug system before servicing.

3-3 Control Panel LEDs

The control panel located on the front of the SC826 chassis has five LEDs. These LEDs provide you with critical information related to different parts of the system. This section explains what each LED indicates when illuminated and any corrective action you may need to take.



- **Power Failure:** When this LED flashes, it indicates a power failure in the power supply.



- **Overheat/Fan Fail:** When this LED flashes it indicates a fan failure. When continuously on (not flashing) it indicates an overheat condition, which may be caused by cables obstructing the airflow in the system or the ambient room temperature being too warm. Check the routing of the cables and make sure all fans are present and operating normally. You should also check to make

sure that the chassis covers are installed. Finally, verify that the heatsinks are



- **NIC2:** Indicates network activity on GLAN2 when flashing.



- **NIC1:** Indicates network activity on GLAN1 when flashing.



- **HDD:** Indicates IDE channel activity. SAS/SATA drive and/or DVD-ROM drive activity when flashing.



- **Power:** Indicates power is being supplied to the system's power supply units. This LED should normally be illuminated when the system is operating.

3-4 Drive Carrier LEDs

Your chassis uses SAS or SATA, but not both at the same time.

SAS/SATA Drives

Each SAS/SATA drive carrier has two LEDs.

- **Green:** Each Serial ATA drive carrier has a green LED. When illuminated, this green LED (on the front of the SATA drive carrier) indicates drive activity. A connection to the SATA backplane enables this LED to blink on and off when that particular drive is being accessed.
- **Red:** The red LED indicates a SAS/SATA drive failure. If one of the SAS/SATA drives fail, you should be notified by your system management software.

Chapter 4

Chassis Setup and Maintenance

4-1 Overview

This chapter covers the steps required to install components and perform maintenance on the chassis. The only tool you will need to install components and perform maintenance is a Phillips screwdriver, and under certain circumstances, a hex wrench. Print this page to use as a reference while setting up your chassis.

4-2 Installation Steps

Removing the Chassis Cover	4-2
Installing Hard Drives	4-3
Installing the Motherboard	4-6
Installing the Air Shroud	4-13
Completing the Installation	4-15



Review the warnings and precautions listed in the manual before setting up or servicing this chassis. These include information in Chapter 2: System Safety and the warning/precautions listed in the setup instructions.

4-3 Removing the Chassis Cover

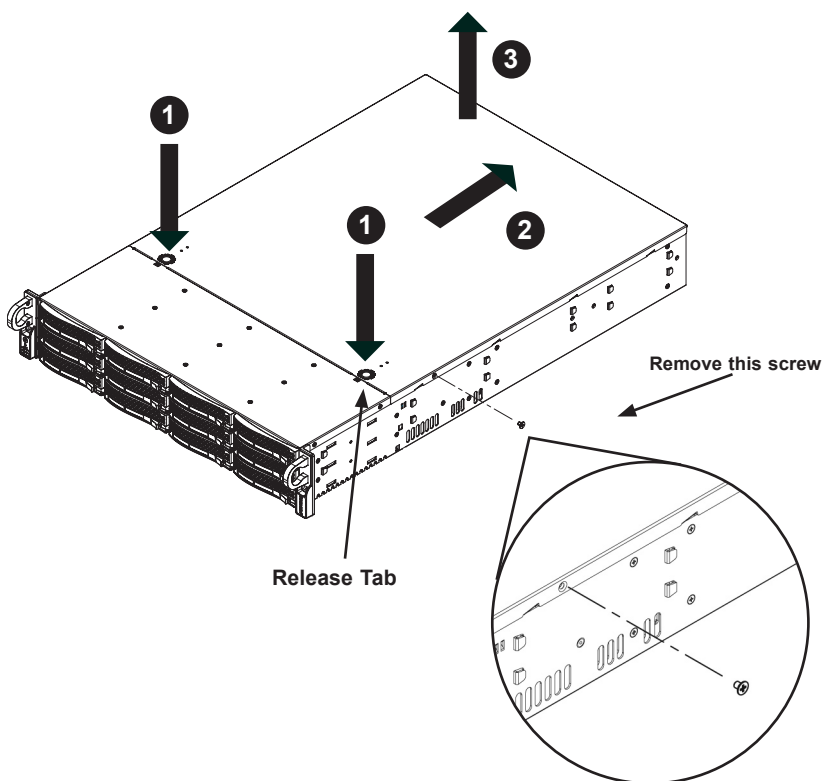

Figure 4-1: Removing the Chassis Cover

Removing the Chassis Cover the chassis cover:

1. Press the release tabs to remove the cover from the locked position. Press both tabs at the same time.
2. Once the top cover is released from the locked position, slide the cover toward the rear of the chassis.
3. Lift the cover off the chassis.



Warning: Except for short periods of time, do NOT operate the server without the cover in place. The chassis cover must be in place to allow proper airflow and prevent overheating.

4-4 Installing Hard Drives

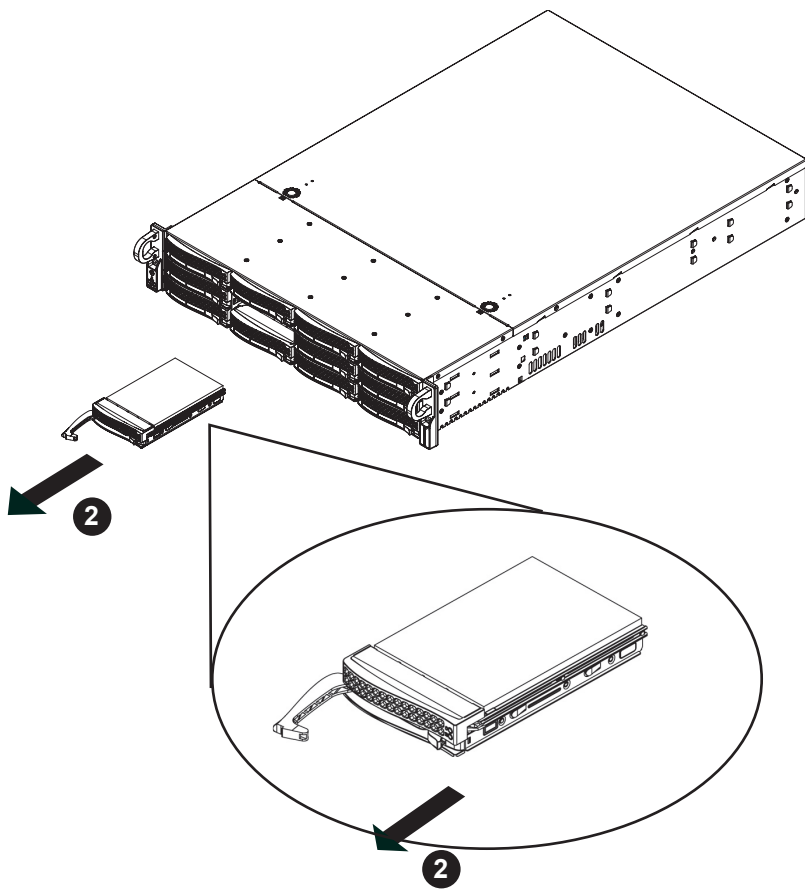

Figure 4-2: Removing Hard Drive Tray

Removing Hard Drive Trays from the Chassis

1. Press the release button on the drive tray. This extends the drive bay handle.
2. Use the handle to pull the drive out of the chassis.

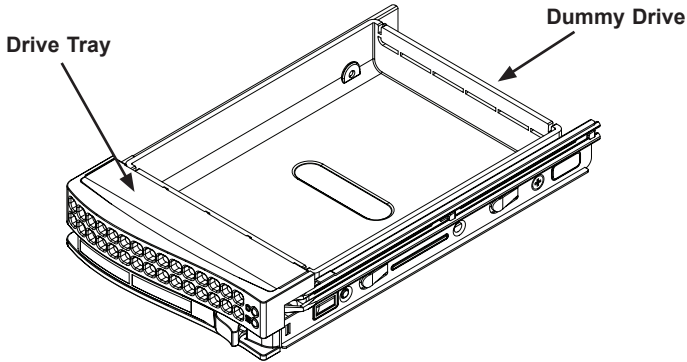

Figure 4-3: Chassis Drive Tray

The drives are mounted in drive carriers to simplify their installation and removal from the chassis. These carriers also help promote proper airflow for the drive bays.



Warning: Except for short periods of time (swapping hard drives), do not operate the server with the hard drives empty.

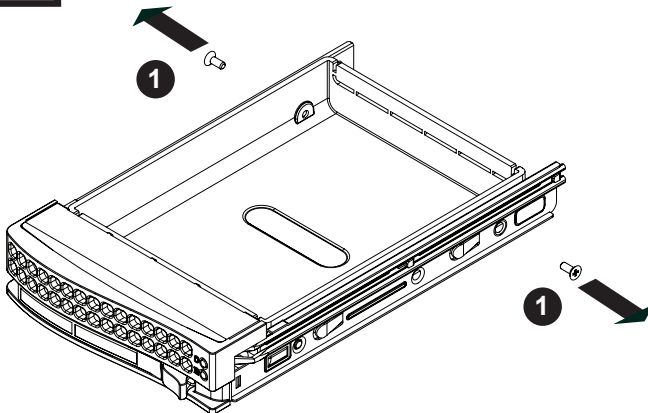

Figure 4-4: Removing Dummy Drive from Tray

Installing a Hard Drive to the Hard Drive Tray

1. Remove the two screws connecting the drive tray to the carrier.
2. Remove the tray from the carrier.

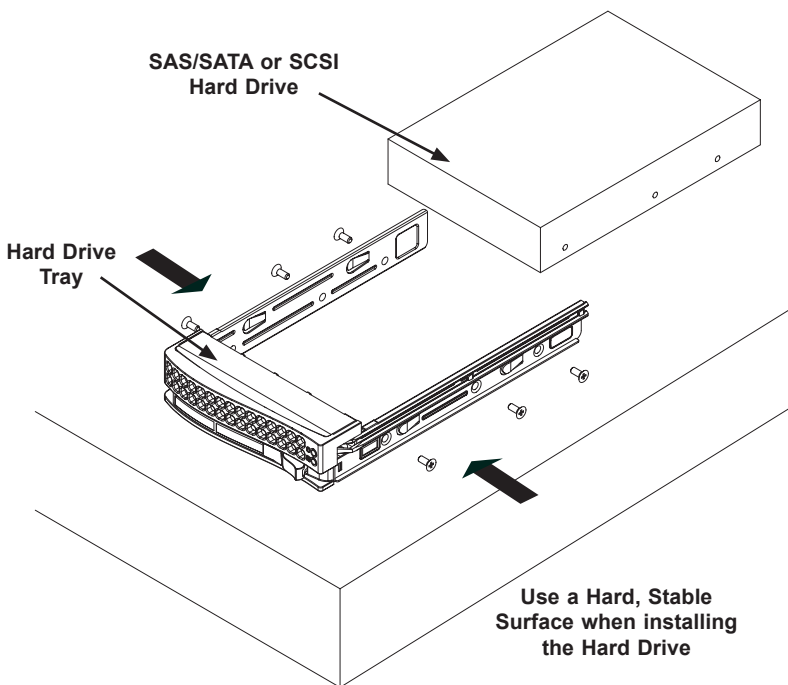

Figure 4-5: Install SAS or SATA Drive to Hard Drive Tray

3. Place the hard drive tray on a flat, stable surface such as a desk, table, or work bench.
4. Slide the hard drive into the tray with the printed circuit board side facing down.
5. Carefully align the mounting holes in the hard drive and the tray. Make sure the bottom of the hard drive and bottom of the hard drive tray are flush.
6. Secure the hard drive using all six screws.
7. Replace the drive tray into the chassis. Make sure to close the drive tray using the drive tray handle.

4-5 Installing the Motherboard

Riser Card Bracket (OEM ONLY)

The SC826 R2 chassis include a riser card that accommodates three full height, full length and three low profile cards. This riser card must be removed before installing the motherboard.

Removing the Riser Card:

1. Remove the chassis cover.
2. Locate the riser card that separates the motherboard compartment.
3. The riser card is held in place by three screws (two in the rear and one in the front). Remove these screws.
4. Carefully pull the riser card from the chassis and place the unit aside for later use.

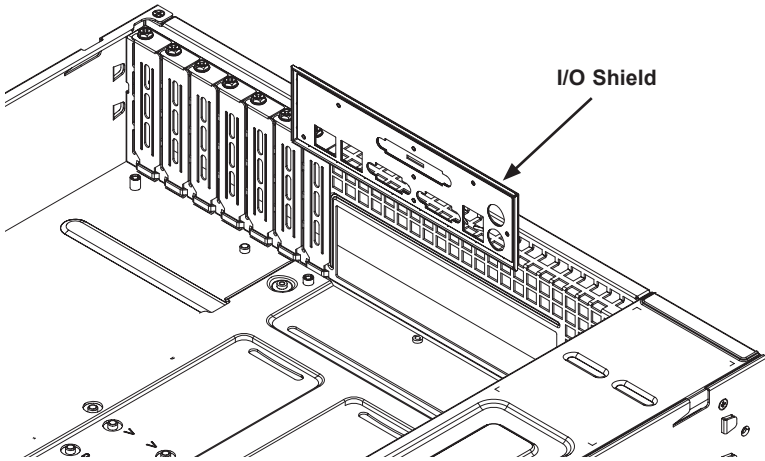

Figure 4-6: I/O Shield Placement

I/O Shield

The I/O shield holds the motherboard ports in place. Install the I/O shield before you install the motherboard.

Installing the I/O Shield

1. Review the documentation that came with your motherboard. Become familiar with component placement, requirements, and precautions.
2. Open the chassis cover.
3. With the illustrations facing the outside of the chassis, place the shield into the space provided.

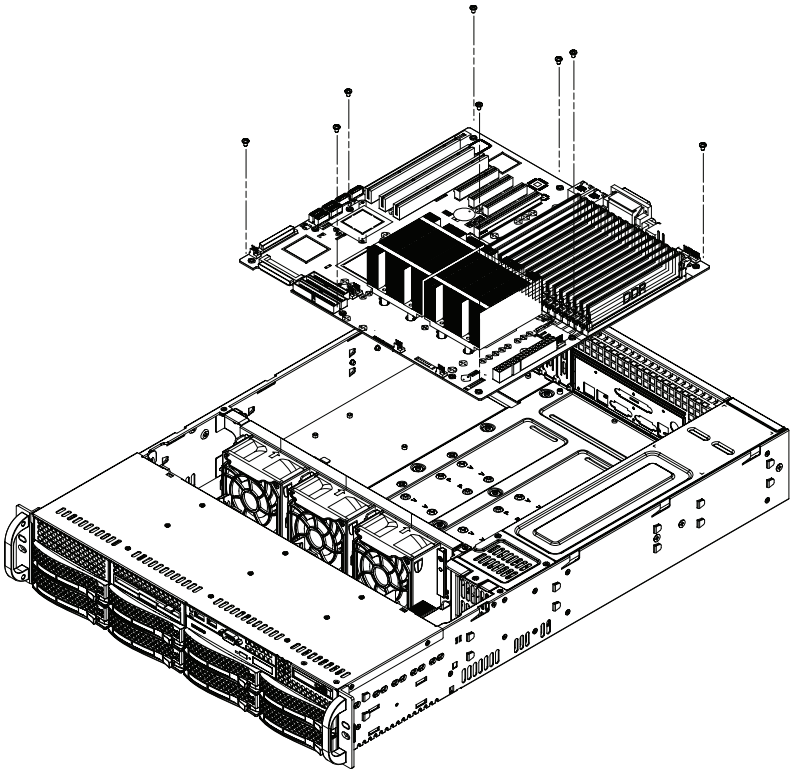

Figure 4-7: Chassis Standoffs

Permanent and Optional Standoffs

Standoffs prevent short circuits by securing space between the motherboard and the chassis surface. The SC826 chassis includes permanent standoffs in locations used by most motherboards. These standoffs accept the rounded Phillips head screws included in the SC826 accessories packaging.

Some motherboards require additional screws for heatsinks, general components and/or non-standard security. Optional standoffs are included to these motherboards. To use an optional standoff, you must place the hexagonal screw through the bottom the chassis and secure the screw with the hexagon nut (rounded side up).

Installing the Motherboard

Installing the Motherboard

1. Review the documentation that came with your motherboard. Become familiar with component placement, requirements, precautions, and cable connections.
2. Open the chassis cover.
3. As required by your motherboard, install standoffs in any areas that do not have a permanent standoff. To do this:
 - a. Place a hexagonal standoff screw through the bottom the chassis.
 - b. Secure the screw with the hexagon nut (rounded side up).
4. Lay the motherboard on the chassis aligning the permanent and optional standoffs
5. Secure the motherboard to the chassis using the rounded, Phillips head screws.
6. Secure the CPU(s), heatsinks, and other components to the motherboard as described in the motherboard documentation.
7. Connect the cables between the motherboard, backplane, chassis, front panel, and power supply, as needed. Also, the fans may be temporarily removed to allow access to the backplane ports.

Add-on Card Setup (SC826 RC chassis - OEM Only)

SC826 chassis RC models allow for up to 3 full height/full length card slots. RC2 allows up to 3 full height/full length card slots and up to 3 low profile cards slots.

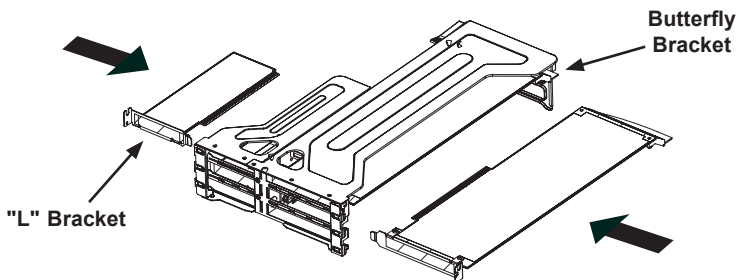

**Figure 4-8: 3 Full Height/Full Length with 3 Low Profile Slot
Butterfly Bracket (Rear View)**

To install add-on to an RC version chassis:

1. Confirm that the motherboard was installed correctly.
2. You must install add-on cards to the butterfly bracket. To do this:
 - a. Make sure each add-on card includes a "L" bracket. The "L" bracket should be included by the add-on card manufacturer.
 - b. For each add-on, slide the card into the bracket until it clicks into place.
3. Slide the riser card into the chassis, aligning with both the motherboard slot and the back panel of the chassis.

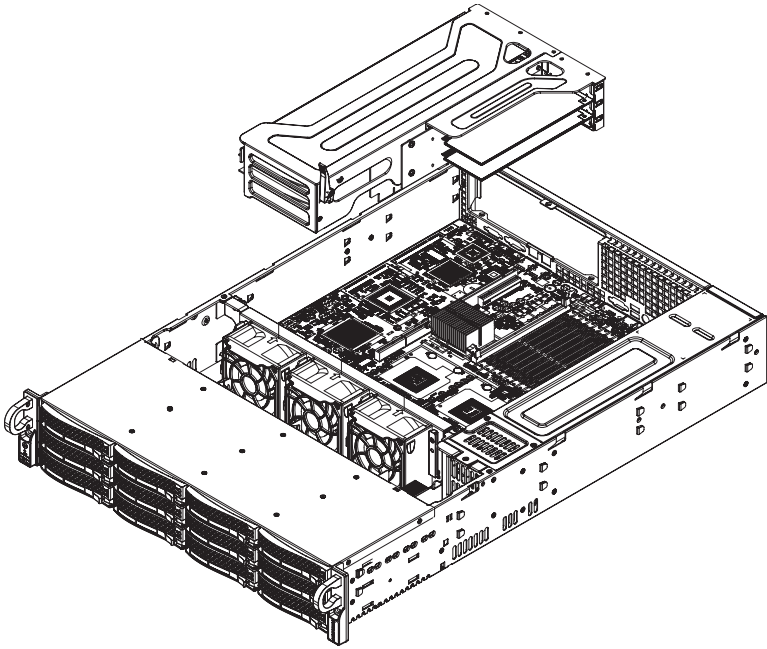

Figure 4-9: 3 Full Height/Full Length with 3 Low Profile Slot

Add-on Card Setup (SC826 LP Chassis)

SC826 chassis provides seven low profile add-on card slots.

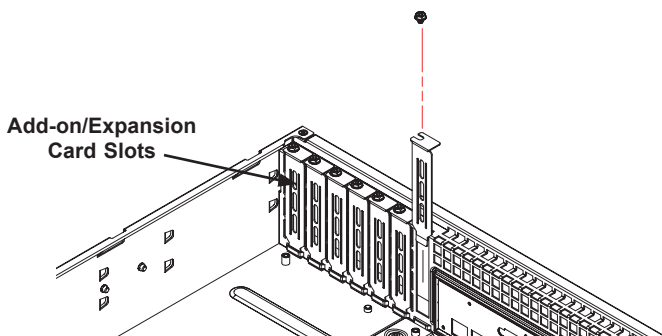

Figure 4-10: SC826 LP model

Installing Add-on Cards in the Sc826lp (Low Profile) Chassis:

1. Disconnect the power supply, lay the chassis on a flat surface, and open the chassis cover.
2. Remove the screw holding the cover in place for each low profile add-on/expansion card slot you want to use. Keep this screw for later use.
3. Connect the add-on cards and/or expansion cards to the mother board.
4. Secure each card to the chassis using the card's L bracket and the screw previously removed.

4-6 Installing the Air Shroud

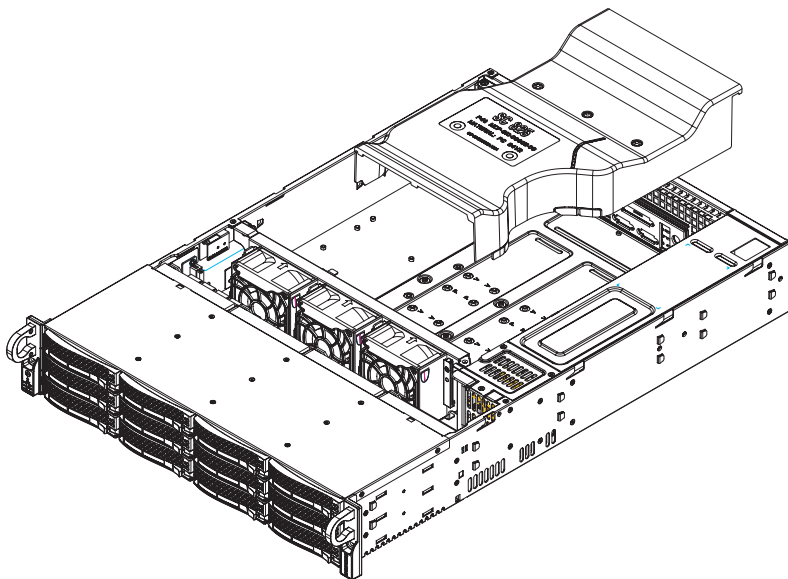

Figure 4-11: Air Shroud for SC826LP Chassis

Air shrouds concentrate airflow to maximize fan efficiency. The SC826 chassis air shroud does not require screws to set up.

Installing the Air Shroud

1. Lay the chassis on a flat, stable surface and remove the chassis cover.
2. If necessary, move any cables that interfere with the air shroud placement.
3. Place the air shroud in the chassis. The air shroud fits just behind the two fans closest to the power supply. Slide the air shroud into the grooves just behind the fan rack.

Note that if a 16 DIMM (13.68" x 13") motherboard is used, it is necessary to use the optional MCP-310-82502-0N air shroud. For ordering information, visit the Supermicro website at www.supermicro.com and click on the Where to Buy link.

4-7 Checking the Air Flow

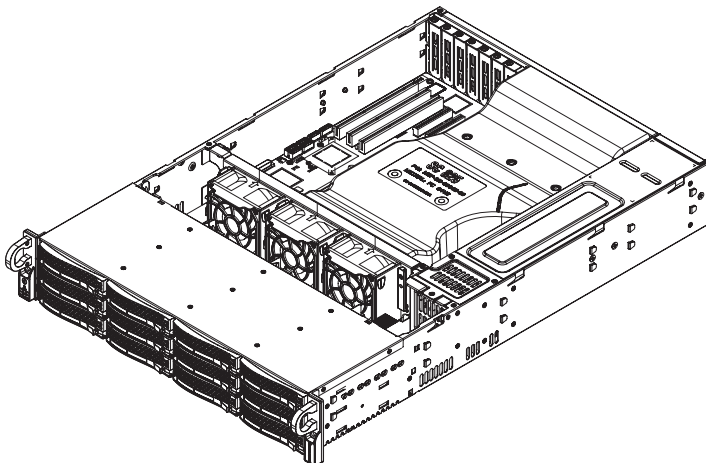

Figure 4-12: Air Shroud in place SC826LP Chassis

Checking the Server's Air Flow

1. Make sure there are no objects to obstruct airflow in and out of the server. In addition, if you are using a front bezel, make sure the bezel's filter is replaced periodically.
2. Do not operate the server without drives or drive trays in the drive bays. Use only recommended server parts.
3. Make sure no wires or foreign objects obstruct air flow through the chassis. Pull all excess cabling out of the airflow path or use shorter cables.

The control panel LEDs inform you of system status. See “Chapter 3: System Interface” for details on the LEDs and the control panel buttons.

Installation Complete

In most cases, the chassis power supply and fans are pre-installed. If you need to install fans continue to the Systems Fan section of this chapter. If the chassis will be installed into a rack, continue to the next chapter for rack installation instructions.

4-8 System Fans

Three heavy duty fans provide cooling for the chassis. These fans circulate air through the chassis as a means of lowering the chassis internal temperature.

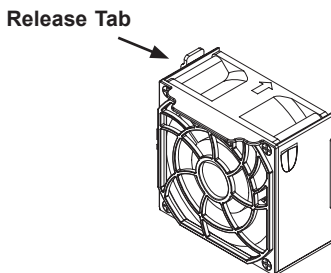

Figure 4-13: System Fan

Replacing a System Fan

1. If necessary, open the chassis while the power is running to determine which fan requires changing. (Never run the server for an extended period of time with the chassis open.)
2. Turn off the power to the system and unplug the system from the outlet.
3. Remove the failed fan's power cord from the serverboard.
4. Press the fan release tab to lift the failed fan from the chassis and pull it completely from the chassis.
5. Place the new fan into the vacant space in the housing while making sure the arrows on the top of the fan (indicating air direction) point in the same direction as the arrows on the other fans.
6. Power up the system and check that the fan is working properly before replacing the chassis cover.

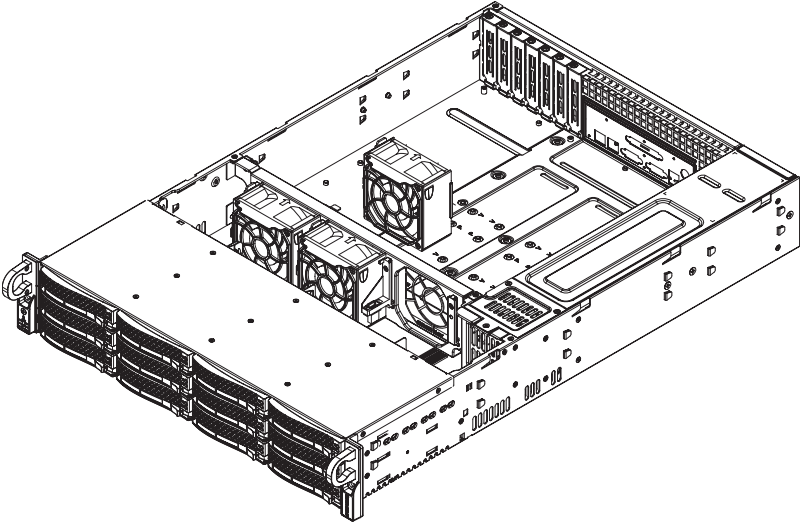

Figure 4-14: Placing the System Fan

4-9 Power Supply

Depending on your chassis model, the SC826 Chassis has a 800 watt power supply. This power supply is auto-switching capable. This enables it to automatically sense and operate at a 100v to 240v input voltage. An amber light will be illuminated on the power supply when the power is off. An illuminated green light indicates that the power supply is operating.

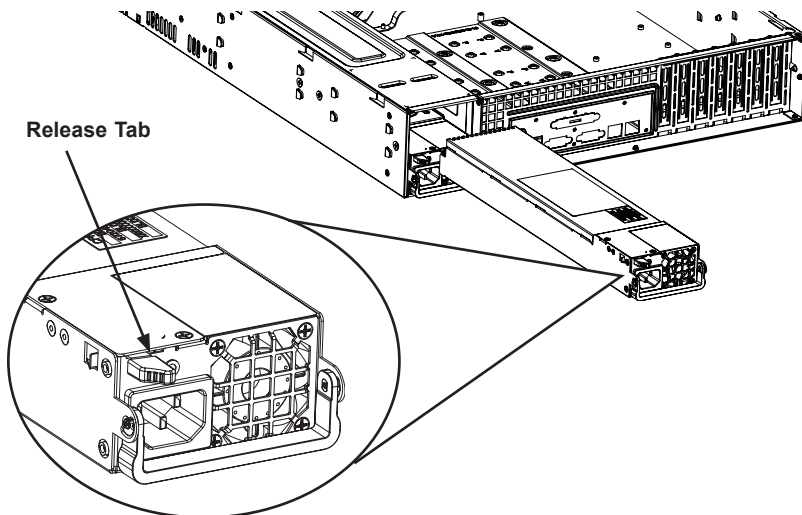

Figure 4-15: Removing the Power Supply

Changing the Power Supply

1. If your chassis includes a redundant power supply (at least two power modules), you can leave the server running and remove only one power supply. If your server has only one power supply, you must power down the server and unplug the power cord.
2. Push the release tab (on the back of the power supply) as illustrated.
3. Pull the power supply out using the handle provided.
4. Replace the failed power module with the same model.
5. Push the new power supply module into the power bay until you hear a click.
6. Plug the AC power cord back into the module and power up the server.

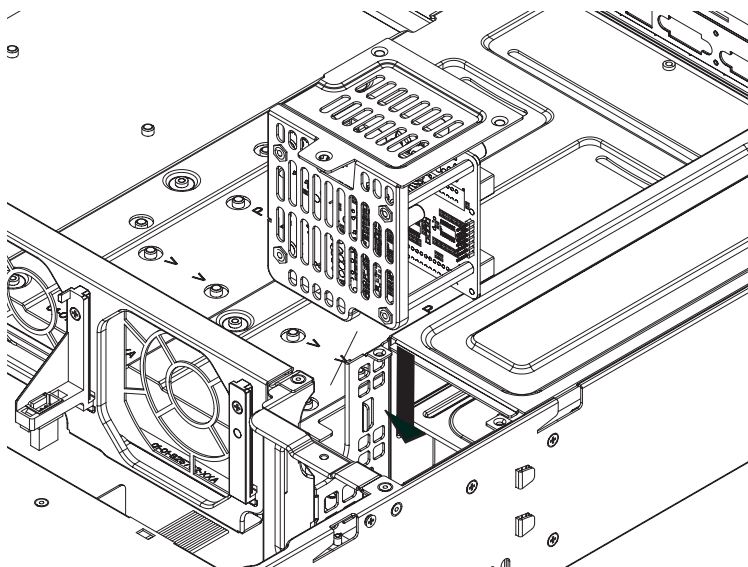

Figure 4-16: Replacing the Power Distributor

Power Distributor

Server chassis that are 2U or more high require a power distributor. The power distributor provides failover and power supply redundancy.

Changing the Power Distributor

1. Power down the server and remove the plug from the wall socket or power strip.
2. Remove all cable connections to the power supply from the motherboard, backplane, and other components. Also, remove both power supplies.
3. Locate the power distributor between the power supply and the fan row.
4. Remove the three screws securing the power supply.
5. Gently pull the power distributor from the chassis. Gently guide all the cables through the power distributor housing.
6. Slide the new power distributor module into the power distributor housing. Make that you slide the cables through the bottom of the housing.
7. Reconnect all the power cables, replace the power supply, and insert the plug into the wall.

4-10 Optional Front Bezel

The SC826 chassis supports an optional full-face locking front bezel for added security. The front bezel is not included with the SC826 chassis, but can be ordered separately by visiting the Supermicro Web site at www.supermicro.com, clicking on the Where to Buy link and referencing part number MCP-210-82601-0B.

Chapter 5

Rack Installation

5-1 Overview

This chapter provides a quick setup checklist to get your chassis up and running. Following these steps in the order given should enable you to have the system operational within a minimum amount of time.

5-2 Unpacking the System

You should inspect the box the chassis was shipped in and note if it was damaged in any way. If the chassis itself shows damage you should file a damage claim with the carrier who delivered it.

Decide on a suitable location for the rack unit that will hold your chassis. It should be situated in a clean, dust-free area that is well ventilated. Avoid areas where heat, electrical noise and electromagnetic fields are generated. You will also need it placed near a grounded power outlet. Be sure to read the Rack and Server Precautions in the next section.

5-3 Preparing for Setup

The box your chassis was shipped in should include two sets of rail assemblies, two rail mounting brackets and the mounting screws you will need to install the system into the rack. Please read this section in its entirety before you begin the installation procedure outlined in the sections that follow.

Choosing a Setup Location

- Leave enough clearance in front of the rack to enable you to open the front door completely (~25 inches).
- Leave approximately 30 inches of clearance in the back of the rack to allow for sufficient airflow and ease in servicing.
- This product is for installation only in a Restricted Access Location (dedicated equipment rooms, service closets and the like).



Warnings and Precautions!



Rack Precautions

- Ensure that the leveling jacks on the bottom of the rack are fully extended to the floor with the full weight of the rack resting on them.
- In single rack installation, stabilizers should be attached to the rack.
- In multiple rack installations, the racks should be coupled together.
- Always make sure the rack is stable before extending a component from the rack.
- You should extend only one component at a time - extending two or more simultaneously may cause the rack to become unstable.

General Server Precautions

- Review the electrical and general safety precautions that came with the components you are adding to your chassis.
- Determine the placement of each component in the rack *before* you install the rails.
- Install the heaviest server components on the bottom of the rack first, and then work up.
- Use a regulating uninterruptible power supply (UPS) to protect the server from power surges, voltage spikes and to keep your system operating in case of a power failure.
- Allow the hot plug hard drives and power supply modules to cool before touching them.
- Always keep the rack's front door and all panels and components on the servers closed when not servicing to maintain proper cooling.

Rack Mounting Considerations

Ambient Operating Temperature

If installed in a closed or multi-unit rack assembly, the ambient operating temperature of the rack environment may be greater than the ambient temperature of the room. Therefore, consideration should be given to installing the equipment in an environment compatible with the manufacturer's maximum rated ambient temperature (T_{mra}).

Reduced Airflow

Equipment should be mounted into a rack so that the amount of airflow required for safe operation is not compromised.

Mechanical Loading

Equipment should be mounted into a rack so that a hazardous condition does not arise due to uneven mechanical loading.

Circuit Overloading

Consideration should be given to the connection of the equipment to the power supply circuitry and the effect that any possible overloading of circuits might have on overcurrent protection and power supply wiring. Appropriate consideration of equipment nameplate ratings should be used when addressing this concern.

Reliable Ground

A reliable ground must be maintained at all times. To ensure this, the rack itself should be grounded. Particular attention should be given to power supply connections other than the direct connections to the branch circuit (i.e. the use of power strips, etc.).

5-4 Rack Mounting Instructions

This section provides information on installing the SC826 chassis into a rack unit with the rails provided. There are a variety of rack units on the market, which may mean the assembly procedure will differ slightly. You should also refer to the installation instructions that came with the rack unit you are using.

NOTE: This rail will fit a rack between 26" and 33.5" deep.

Identifying the Sections of the Rack Rails

The chassis package includes two rack rail assemblies in the rack mounting kit. Each assembly consists of two sections: an inner fixed chassis rail that secures directly to the server chassis and an outer fixed rack rail that secures directly to the rack itself.

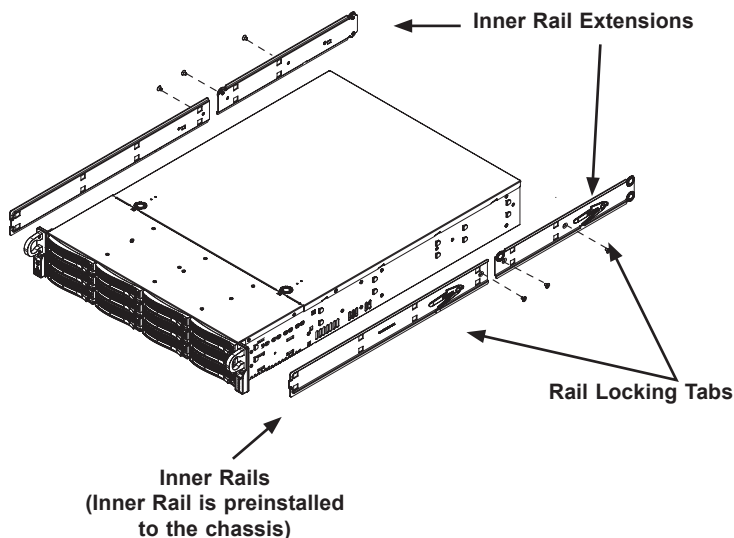
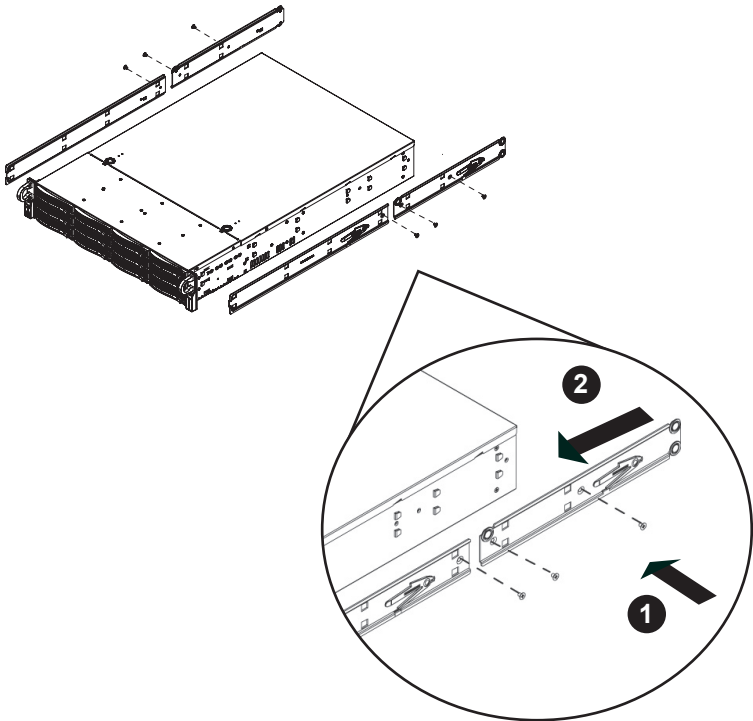

Figure 5-1. Identifying the Sections of the Rack Rails

Locking Tabs

Both chassis rails have a locking tab. The tabs lock the server into place when installed and pushed fully into the rack. These tabs also lock the server in place when fully extended from the rack. This prevents the server from coming completely out of the rack when you pull it out for servicing.



**Figure 5-2. Identifying the Sections of the Rack Rails
(right side rail shown)**

The Inner Rail Extension

The inner rails are pre-attached and do not interfere with normal use of the chassis if you decide not to use a server rack. Attach the inner rail extension to stabilize the chassis within the rack. If you are not using a rack, you do not have to install the inner rail extensions.

Installing the Inner Rails

1. Place the inner rack extensions on the side of the chassis aligning the hooks of the chassis with the rail extension holes. Make sure the extension faces "outward" just like the pre-attached inner rail.
2. Slide the extension toward the front of the chassis.
3. Secure the chassis with 2 screws as illustrated. Repeat steps for the other inner rail extension.

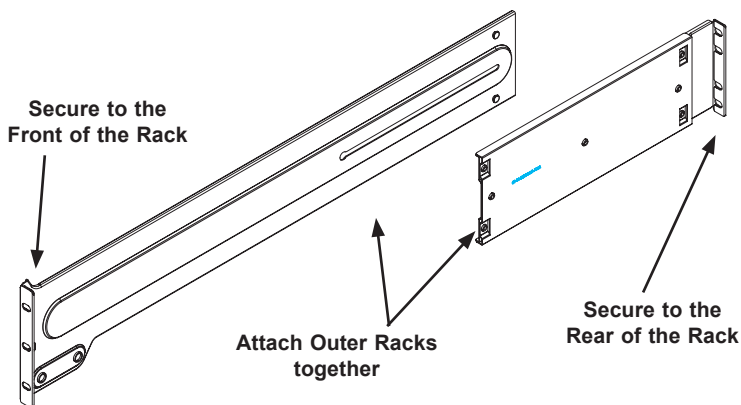

Figure 5-3. Assembling the Outer Rails

Outer Rack Rails

Outer rails attach to the server rack and hold the server in place. The outer rails for the SC826 chassis extend between 30 inches and 33 inches.

Installing the Outer Rails to the Rack

1. Attach the short bracket to the outside of the long bracket. You must align the pins with the slides. Also, both bracket ends must face the same direction.
2. Adjust both the short and long brackets to the proper distance so that the rail fits snugly into the rack.
3. Secure the long bracket to the front side of the outer rail with two M5 screws and the short bracket to the rear side of the outer rail with three M5 screws.
4. Repeat steps 1-4 for the left outer rail.

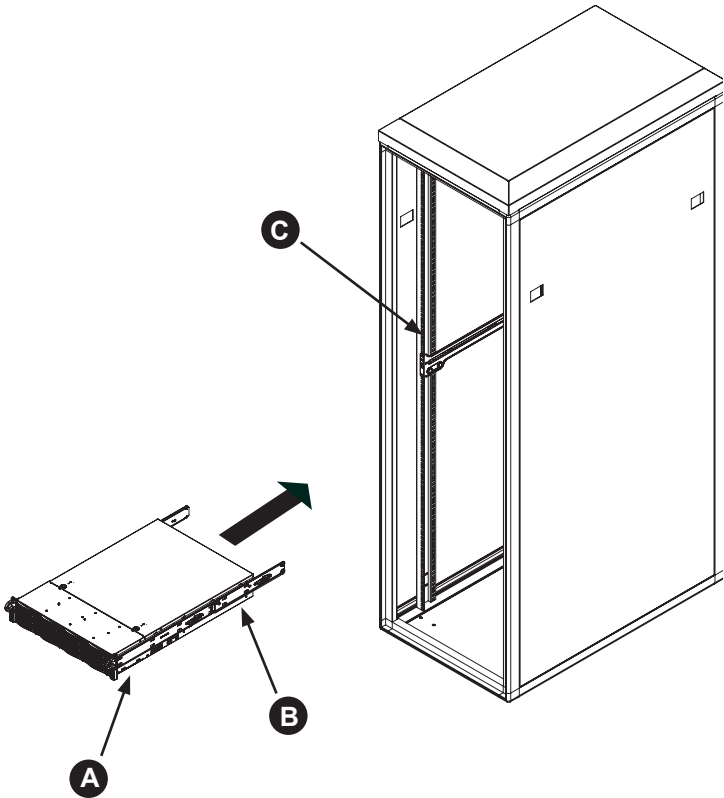

Figure 5-4: Installing the Rack Rails

Installing the Chassis into a Rack

1. Confirm that chassis includes the inner rails (A) and rail extensions (B). Also, confirm that the outer rails (C) are installed on the rack.
2. Line chassis rails (A and B) with the front of the rack rails (C).
3. Slide the chassis rails into the rack rails, keeping the pressure even on both sides (you may have to depress the locking tabs when inserting). When the server has been pushed completely into the rack, you should hear the locking tabs "click".
4. (Optional) Insert and tightening the thumbscrews that hold the front of the server to the rack.

Notes

Appendix A

SC826 Chassis Cables

A-1 Overview

This appendix lists supported cables for your chassis system. It only includes the most commonly used components and configurations. For more compatible cables, refer to the manufacturer of the motherboard you are using and our Web site at: www.supermicro.com.

A-2 Cables Included with SC826 Chassis (SAS/SATA)

Part #	Type	Length	Description
CBL-0087	Cable	20"	Round 16 to 16 pin ribbon front panel cable
CBL--0160L	Cable		US power cord 16 AWG, PB free
CBL-0217L	Cable		16 pin control panel converter cable for SC826 PBF
CBL-0157L	Cable	9"	8 pin to 8 pin ribbon cable for SGPIO, PB free
CBL-0191L	Cable	50 cm	20 pin to 20 pin cable for control panel
CBL-0139L	Wire	50 cm	IDE 80-Wire cable for DVD ROM
-	Cable	6'	Two regional power cords
CBL-0180L	SATA	various	Set for 4 SATA Cables. Length varied to minimize airflow interference.
CBL-0078	Cable	45 cm	Round floppy cable

A-3 Compatible Cables

These cables are compatible with the SC826 Chassis.

Alternate SAS/SATA Cables

Some compatible motherboards have different connectors. If your motherboard has only one SAS connector that the SAS/SATA cables must share, use one of the following cables. These cables must be purchased separately.

Cable Name: SAS Cable

Quantity: 1

Part #: CBL-0175L

Alt. Name: "Big Four"

Description: This cable has one SFF-8484 (32 pin) connector on one end and 4 SAS connectors (7 pins each) at the other. This cable connects from the Host (motherboard or other controller) to the backplane SAS hard drive port.

Cable Name: SAS Cable

Quantity: 1

Part #: CBL-0116

Alt. Name: iPass or "Small Four"

Description: This cable has one ipass (SFF-8087/mini-sas) connector (36 pins) at one end and 4 SAS connectors on one end. This cable connects from the Host (motherboard or other controller) to the backplane SAS hard drive port.

Extending Power Cables

Although Super Micro chassis are designed to be efficient and cost-effective, some compatible motherboards have power connectors located in different areas.

To use these motherboards you may have to extend the power cables to the motherboards. To do this, use the following chart as a guide.

Power Cable Extenders		
Number of Pins	Cable Part #	Length
24 pin	CBL - 0042	7.9"(20 CM)
20 pin	CBL - 0059	7.9"(20 CM)
8 pin	CBL - 0062	7.9"(20 CM)
4 pin	CBL - 0060	7.9"(20 CM)

Front Panel to the Motherboard

The SC826 chassis includes a cable to connect the chassis front panel to the motherboard. If your motherboard uses a different connector, use the following list to find a compatible cable.

Front Panel to Motherboard Cable (Ribbon Cable)		
Number of Pins (Front Panel)	Number of Pins (Motherboard)	Cable Part #
16 pin	16 pin	CBL - 0049
16 pin	20 pin	CBL - 0048
20 pin	20 pin	CBL - 0047
16 pin	various*	CBL - 0068
20 pin	various*	CBL - 0067

* Split Cables: Use these cable if your motherboard requires several different connections from the front panel.

Notes

Appendix B**SC826 Power Supply Specifications**

This appendix lists power supply specifications for your chassis system.

SC826	
	800W
MFR Part #	PWS-801-1R
Rated AC Voltage	100 - 240V 50 - 60Hz 10 - 4 Amp
+5V standby	4 Amp
+12V	66 Amp
+5V	30 Amp
+3.3V	24 Amp
-12V	0.6 Amp

Notes

Appendix C

BPN-SAS 826TQ Backplane Specifications

To avoid personal injury and property damage, carefully follow all the safety steps listed below when accessing your system or handling the components.

C-1 ESD Safety Guidelines

Electric Static Discharge (ESD) can damage electronic components. To prevent damage to your system, it is important to handle it very carefully. The following measures are generally sufficient to protect your equipment from ESD.

- Use a grounded wrist strap designed to prevent static discharge.
- Touch a grounded metal object before removing a component from the antistatic bag.
- Handle the RAID card by its edges only; do not touch its components, peripheral chips, memory modules or gold contacts.
- When handling chips or modules, avoid touching their pins.
- Put the card and peripherals back into their antistatic bags when not in use.

C-2 General Safety Guidelines

- Always disconnect power cables before installing or removing any components from the computer, including the SAS 826TQ Backplane.
- Disconnect the power cable before installing or removing any cables from the SAS 826TQ Backplane.
- Make sure that the SAS 826TQ Backplane is securely and properly installed on the motherboard to prevent damage to the system due to power shortage.

C-3 An Important Note to Users

- All images and layouts shown in this user's guide are based upon the latest PCB Revision available at the time of publishing. The card you have received may or may not look exactly the same as the graphics shown in this manual.

Jumper Settings and Pin Definitions

C-4 Front Connectors and Jumpers

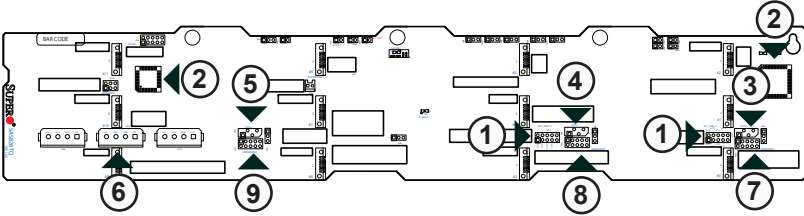

Front Connectors

- | | |
|--|-----------------------|
| #1. ACT_IN: JP26 and JP47 | #11. SAS Port #1 J6 |
| #2. Chips: MG 9071 and MG 9072 | #12. SAS Port #2 J7 |
| #3. I ² C Connector#1 JP37 | #13. SAS Port #3 J8 |
| #4. I ² C Connector#2 JP95 | #14. SAS Port #4 J10 |
| #5. I ² C Connector#3 JP52 | #15. SAS Port #5 J12 |
| #6. Power Connectors (4-pin): JP10, JP13, and JP46 | #16. SAS Port #6 J14 |
| #7. SideBand Connector#1 JP66 | #17. SAS Port #7 J16 |
| #8. SideBand Connector#2 JP68 | #18. SAS Port #8 J22 |
| #9. SideBand Connector#3 JP75 | #19. SAS Port #9 J23 |
| #10. SAS Port #0 J5 | #20. SAS Port #10 J24 |
| | #21. SAS Port #11 J25 |

SAS Ports

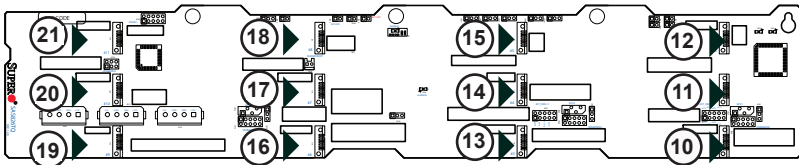

C-5 Front Connector and Pin Definitions

#1. Activity LED Header

The activity LED header, designated JP26 and JP47, is used to indicate the activity status of each SAS drive. The Activity LED Header is located on the front panel. For the Activity LED Header to work properly, connect using a 10-pin LED cable.

SAS Activity LED Header Pin Definitions (JP26)			
Pin #	Definition	Pin #	Definition
1	ACT IN#0	6	ACT IN#4
2	ACT IN#1	7	ACT IN#5
3	ACT IN#2	8	ACT IN#6
4	ACT IN#3	9	ACT IN#7
5	Ground	10	Empty

SAS Activity LED Header Pin Definitions (JP47)			
Pin #	Definition	Pin #	Definition
1	ACT IN#8	6	ACT IN#12
2	ACT IN#9	7	ACT IN#13
3	ACT IN#10	8	ACT IN#14
4	ACT IN#11	9	ACT IN#15
5	Ground	10	Empty

#2. MG9071 and MG9072 Chips

The MG9071 and MG9072 are enclosure management chips that support the SES-2 controller and SES-2 protocols.

#3/#4/#5. I²C Connectors

The I²C Connectors, designated JP37, JP52, and JP95, are used to monitor HDD activity and status. See the table on the right for pin definitions.

I ² C Connector Pin Definitions (JP37, JP52, and JP95)	
Pin#	Definition
1	Data
2	Ground
3	Clock
4	No Connection

#6. Backplane Main Power Connectors

The 4-pin connectors, designated JP10, JP13, and JP46 provide power to the backplane. See the table on the right for pin definitions.

Backplane Main Power 4-Pin Connector (JP10, JP13, and JP46)	
Pin#	Definition
1	+12V
2 and 3	Ground
4	+5V

#7/#8/#9. Sideband Headers

The sideband headers are designated JP66, JP68, and JP75. For SES-2 to work properly, you must connect an 8-pin sideband cable. See the table to the right for pin definitions.

Sideband Headers (JP66, JP68, and JP75)			
Pin #	Definition	Pin #	Definition
2	Backplane Addressing (SB5)	1	Controller ID (SB6)
4	Reset (SB4)	3	GND (SB2)
6	GND (SB3)	5	SDA (SB1)
8	Backplane ID (SB7)	7	SCL (SB0)
10	No Connection	9	No Connection

#10-#21. SAS Ports

The SAS ports are used to connect the SAS drive cables. The 12 ports are designated #0 - #11. Each port is also compatible with SATA drives.

C-6 Front Jumper Locations and Pin Definitions

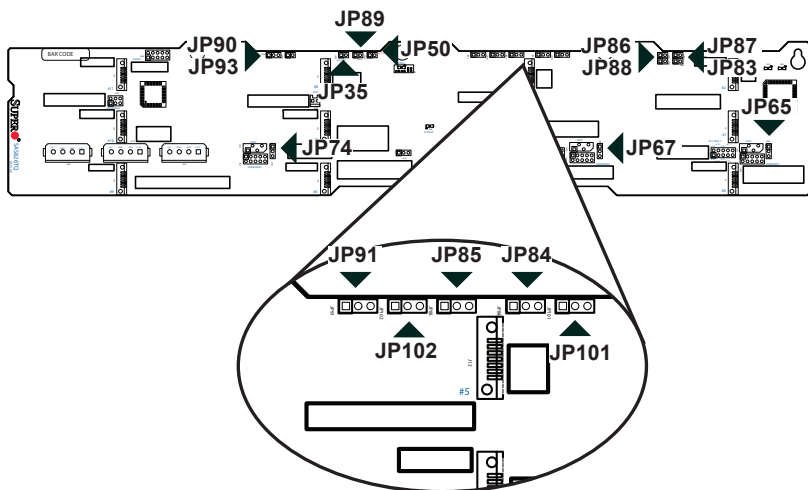

Explanation of Jumpers

To modify the operation of the backplane, jumpers can be used to choose between optional settings. Jumpers create shorts between two pins to change the function of the connector. Pin 1 is identified with a square solder pad on the printed circuit board. **Note:** On two pin jumpers, "Closed" means the jumper is on and "Open" means the jumper is off the pins.

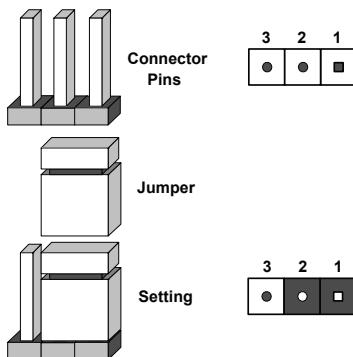

Jumper Settings		
Jumper	Jumper Settings	Note
JP35	Open: Default Closed: Reset	9072 Chip Reset #1
JP50	Open: Default Closed: Reset	9071 Chip Reset #2

I²C and SGPIO Modes and Jumper Settings

This backplane can utilize I²C or SGPIO. I²C is the default mode and can be used without making changes to your jumpers. The following information details which jumpers must be configured to use SGPIO mode or restore your backplane to I²C mode.

I²C Setting (Default)		
Jumper	Jumper Setting	Note
JP65	2-3	Backplane ID SDIN #1
JP67	2-3	Backplane ID SDIN #2
JP74	2-3	Backplane ID SDIN #3
JP83	Closed	I ² C Reset #1
JP84	2-3	Controller ID #1
JP85	1-2:ID#0	Backplane ID #1
JP86	Closed	I ² C Reset #2
JP87	Open	I ² C Reset SDOUT #1
JP88	Open	I ² C Reset SDOUT #2
JP89	Closed	I ² C Reset #3
JP90	2-3	Controller ID #3
JP91	1-2:ID#0	Backplane ID #3
JP93	Open	I ² C Reset SDOUT #3
JP101	2-3	Controller ID #2
JP102	2-3:ID#1	Backplane ID #2

SGPIO Setting		
Jumper	Jumper Setting	Note
JP65	1-2	Blackplane ID SDIN #1
JP67	1-2	Blackplane ID SDIN #2
JP74	1-2	Blackplane ID SDIN #3
JP83	Open	I ² C Reset #1
JP84	1-2	Controller ID #1
JP85	1-2	Backplane ID #1
JP86	Open	I ² C Reset #2
JP87	Closed	I ² C Reset SDOOUT #1
JP88	Closed	I ² C Reset SDOOUT #2
JP89	Open	I ² C Reset #3
JP90	1-2	Controller ID #3
JP91	1-2	Backplane ID #3
JP93	Closed	I ² CRST_SDOOUT #3
JP101	1-2	Controller ID #2
JP102	1-2	Backplane ID #2

SAS Port Connections in I²C and SGPIO Settings

Use the following chart when connecting this backplane. If you connect the SAS ports out of order, you will not be able to easily identify drives using the LED function.

SAS Port Connections in I²C and SGPIO Settings		
Port #	I²C	SGPIO
# 0 - 3	I ² C #1	Sideband #1
# 4 - 7	I ² C #2	Sideband #2
# 8 - 11	I ² C #3	Sideband #3

FRONT LED INDICATORS

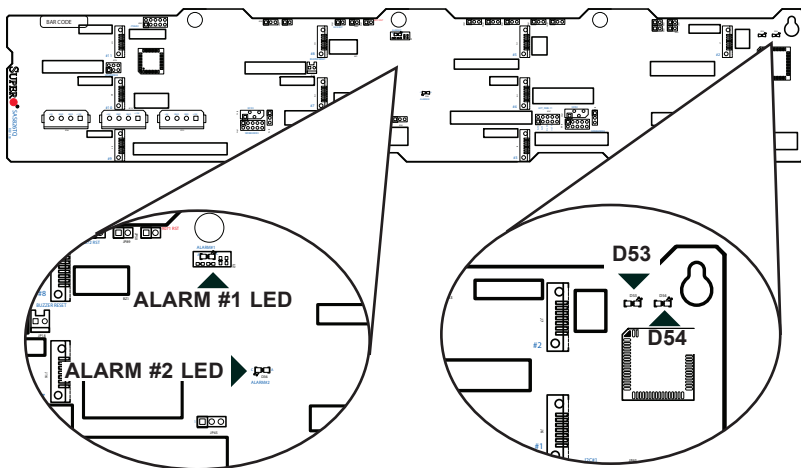

Front Pane LEDs		
LED	STATE	SPECIFICATION
Alarm #1 (D3)	ON	Overheat in Channel 1.
Alarm #2 (D36)	ON	Overheat in Channel 2.
D53	ON	Indicates +5V power. Light is on during normal operation.
D54	ON	Indicates +12V power. Light is on during normal operation.

C-7 Rear Connectors and LED Indicators

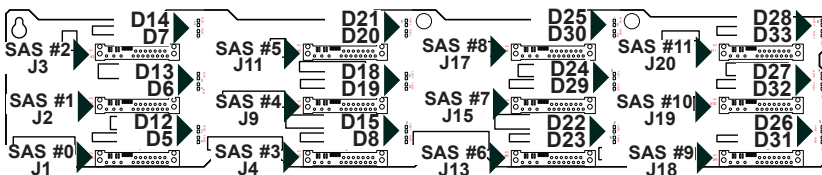

Rear SAS/SATA Connectors

Rear Connector	SAS Drive Number	Rear Connector	SAS Drive Number
SAS #0	SAS/SATA HDD #0	SAS #6	SAS/SATA HDD #6
SAS #1	SAS/SATA HDD #1	SAS #7	SAS/SATA HDD #7
SAS #2	SAS/SATA HDD #2	SAS #8	SAS/SATA HDD #8
SAS #3	SAS/SATA HDD #3	SAS #9	SAS/SATA HDD #9
SAS #4	SAS/SATA HDD #4	SAS #10	SAS/SATA HDD #10
SAS #5	SAS/SATA HDD #5	SAS #11	SAS/SATA HDD #11

Rear LED Indicators

Rear LED	Hard Drive Activity	Failure LED
SAS #0	D12	D5
SAS #1	D13	D6
SAS #2	D14	D7
SAS #3	D15	D8
SAS #4	D18	D19
SAS #5	D21	D20
SAS #6	D22	D23
SAS #7	D24	D29
SAS #8	D25	D30
SAS #9	D26	D31
SAS #10	D27	D32
SAS #11	D28	D33

Appendix D

BPN-SAS-826EL Backplane Specifications

To avoid personal injury and property damage, carefully follow all the safety steps listed below when accessing your system or handling the components.

D-1 ESD Safety Guidelines

Electric Static Discharge (ESD) can damage electronic components. To prevent damage to your system, it is important to handle it very carefully. The following measures are generally sufficient to protect your equipment from ESD.

- Use a grounded wrist strap designed to prevent static discharge.
- Touch a grounded metal object before removing a component from the antistatic bag.
- Handle the RAID card by its edges only; do not touch its components, peripheral chips, memory modules or gold contacts.
- When handling chips or modules, avoid touching their pins.
- Put the card and peripherals back into their antistatic bags when not in use.

D-2 General Safety Guidelines

- Always disconnect power cables before installing or removing any components from the computer, including the SAS 826EL series Backplanes.
- Disconnect the power cable before installing or removing any cables from the SAS 826EL series Backplanes.
- Make sure that the SAS 826EL series Backplanes are securely and properly installed on the motherboard to prevent damage to the system due to power shortage.

D-3 An Important Note to Users

- All images and layouts shown in this user's guide are based upon the latest PCB Revision available at the time of publishing. The card you have received may or may not look exactly the same as the graphics shown in this manual.

Backplane Jumpers, Connectors, LEDs, and Pin Definitions

D-4 Front Connectors and Jumpers

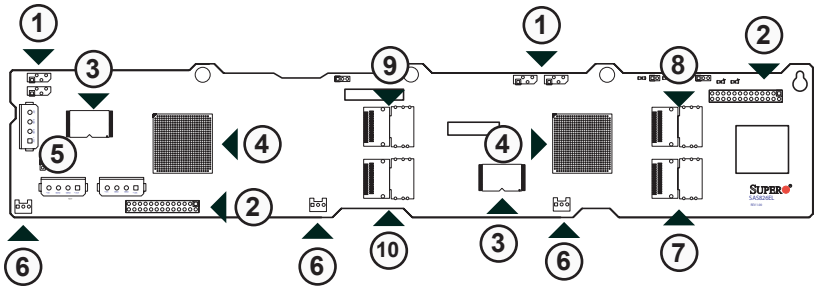

SC 826 EL2 Backplane

Front Connectors

- | | |
|--|--|
| <ol style="list-style-type: none"> 1. Primary and Secondary I²C connectors (four connectors total) 2. EPP Connectors: J16 and J17 3. Primary and Secondary Flash Chips 4. Primary and Secondary Expander Chips 5. Power Connectors: PWR0, PWR1, and PWR3 6. Fan Connectors: Fan1, Fan2, and Fan3 7. Primary SAS Connectors: PRI_J0 | <ol style="list-style-type: none"> 8. Primary SAS Connectors: PRI_J1 9. Secondary SAS Connectors: SEC_J0 (not available in EL1 single port backplane) 10. Secondary SAS Connectors: SEC_J1 (not available in EL1 single port backplane) |
|--|--|

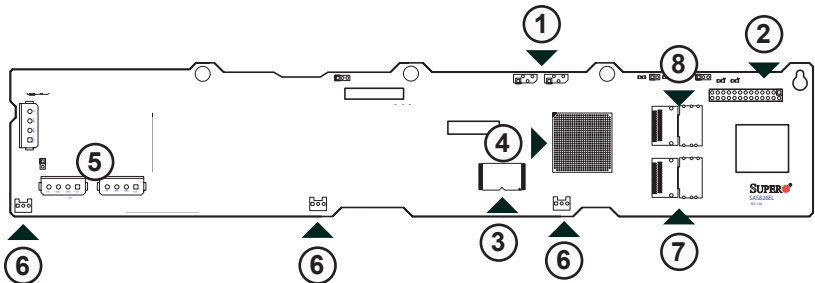

D-5 Front Connector and Pin Definitions

1. Primary and Secondary I²C Connectors

The I²C Connectors are used to monitor hard drive activity and status through LED. See the table on the right for pin definitions. There are four total connectors--two primary and two secondary.

These connectors are optional and should only be used by qualified technicians.

PC Connector Pin Definitions	
Pin#	Definition
1	Data
2	Ground
3	Clock
4	No Connection

2. EPP Ports

The EPP ports are used for manufacturer diagnostic purposes only.

#6. Primary and Secondary Flash Chips

The Primary and Secondary Flash Chips enhance the backplane memory.

4. Primary and Secondary Expander Chips

This Primary and Secondary Expander Chips allow the backplane to support dual port, cascading, and failover configurations.

5. Backplane Main Power Connectors

The 4-pin connectors, designated PWR0, PWR1, and PWR3, provide power to the backplane. See the table on the right for pin definitions.

Backplane Main Power 4-Pin Connector (PWR0, PWR1, and PWR3)	
Pin#	Definition
1	+12V
2 and 3	Ground
4	+5V

6. Fan Connectors

The 3-pin connectors, designated Fan1, Fan2, and Fan3, provide power to the fans.

See the table on the right for pin definitions.

Fan Connectors (Fan1, Fan2, and Fan3)	
Pin#	Definition
1	Ground
2	+12V
3	Tachometer

7-10. SAS Ports

SAS port connectors.

D-6 Front Jumper Locations and Pin Definitions

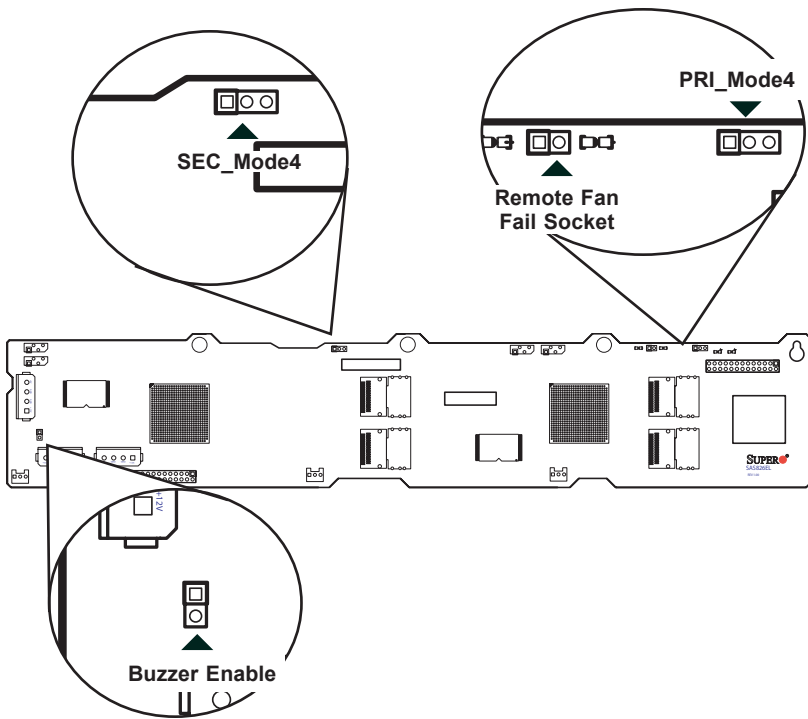

Explanation of Jumpers

To modify the operation of the backplane, jumpers can be used to choose between optional settings. Jumpers create shorts between two pins to change the function of the connector. Pin 1 is identified with a square solder pad on the printed circuit board. Note: On two pin jumpers, "Closed" means the jumper is on and "Open" means the jumper is off the pins.

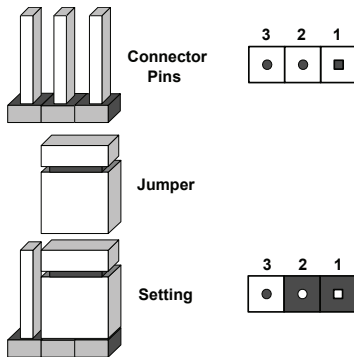

General Jumper Settings		
Jumper	Jumper Settings	Note
PRI_MODE4	1-2	Factory Setting Do not change
SEC_MODE4	1-2	Factory Setting Do not change
BUZZER_ENB1	Open: Disable Closed: Enable	Buzzer Enable

Socket Settings		
Socket	Socket Setting	Note
REMOTE_FAN_FAIL_SOCKET	Connected	Front Panel Fan Fail indicator (Optional)

Front LED Indicators

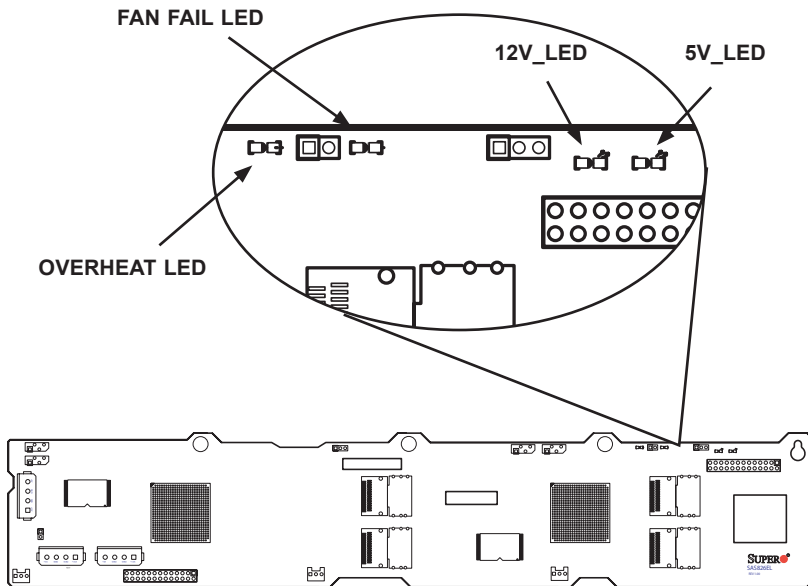

Backplane LEDs

LED	STATE	SPECIFICATION
OVERHEATFAIL1	ON	Overheat or Drive Failure
FANFAIL1	ON	Failure in System Fans
5V	OFF	Backplane power failure. Light is on during normal operation.
12V	OFF	Backplane power failure. Light is on during normal operation.

D-7 Rear Connectors and LED Indicators

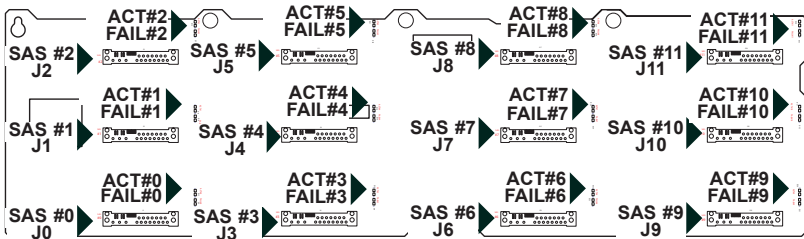

Rear SAS Connectors

Rear Connector	SAS Drive Number	Rear Connector	SAS Drive Number
SAS #0	SAS HDD #0	SAS #6	SAS HDD #6
SAS #1	SAS HDD #1	SAS #7	SAS HDD #7
SAS #2	SAS HDD #2	SAS #8	SAS HDD #8
SAS #3	SAS HDD #3	SAS #9	SAS HDD #9
SAS #4	SAS HDD #4	SAS #10	SAS HDD #10
SAS #5	SAS HDD #5	SAS #11	SAS HDD #11

Rear LED Indicators

Rear LED	Hard Drive Activity	Failure LED
SAS #0	ACT #0	FAIL #0
SAS #1	ACT #1	FAIL #1
SAS #2	ACT #2	FAIL #2
SAS #3	ACT #3	FAIL #3
SAS #4	ACT #4	FAIL #4
SAS #5	ACT #5	FAIL #5
SAS #6	ACT #6	FAIL #6
SAS #7	ACT #7	FAIL #7
SAS #8	ACT #8	FAIL #8
SAS #9	ACT #9	FAIL #9
SAS #10	ACT #10	FAIL #10
SAS #11	ACT #11	FAIL #11

Dual Port and Cascading Configurations

D-8 Single and Dual Port Expanders

Single Ports

SC 826EL1 backplanes have a single-port expander that access all 12 drives and supports cascading.

Dual Ports

SC 826EL2 backplanes have dual-port expanders that access all 12 drives. These dual-port expanders support cascading, failover, and recovery.

Warning: The SAS 826EL2 backplane's J0 and J1 SAS ports reversed in the Secondary Expander Ports B with J0 on top and J1 on the bottom.

SAS 826EL1 Single-Port Backplane

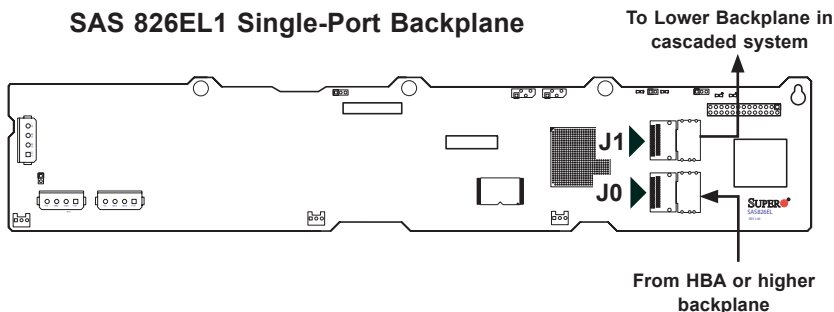

SAS 826EL2 Dual-Port Backplane

Port B
Secondary Ports
Expander 2

Port A
Primary Ports
Expander 1

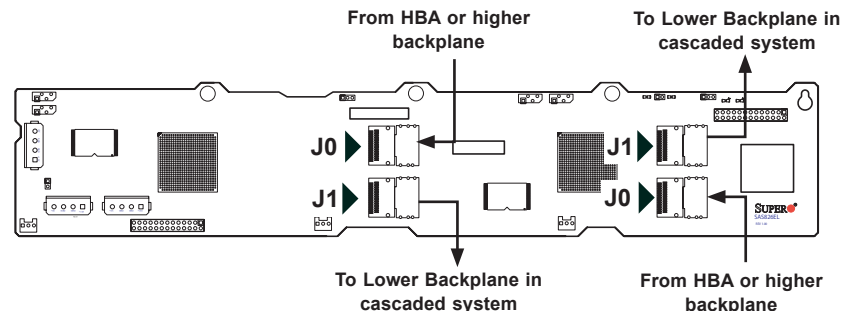

D-9 Failover

The 826EL2 Backplane has two expanders which allow effective failover and recovery.

Single Host Bus Adapter

In a single host bus configuration, the backplane connects to one Host Bus Adapter (HBA).

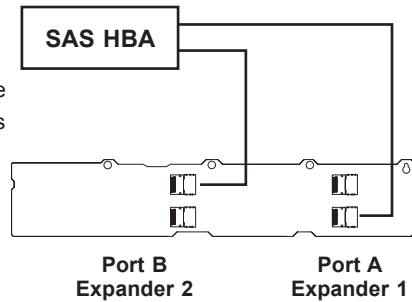

Single Host Bus Adapter Failover

If the Expander or data path in Port A fails, the system will automatically fail over to Port B.

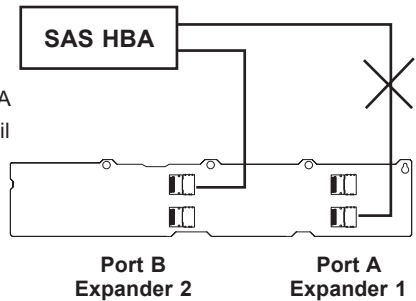

Dual Host Bus Adapter

In a Dual Host Bus Configuration, the backplane connects to two Host Bus Adapters (HBA).

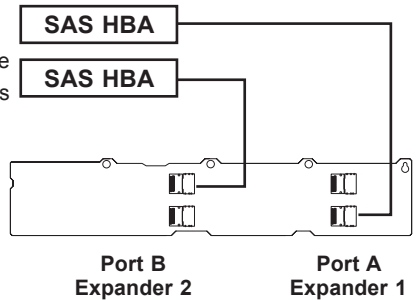

Dual Host Bus Adapter Failover

If the Expander or data path in Port A fails, the system will automatically fail over to Port B. This maintains a full connection to all drives.

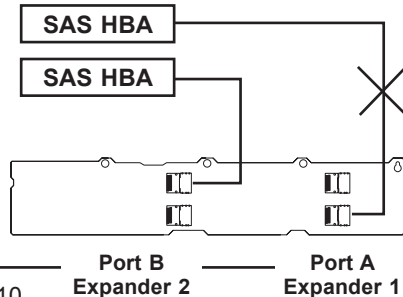

D-10 Cables and Chassis Power Card

Chassis Power Card

In a cascaded configuration, the first chassis includes a motherboard and, at least one, Host Bus Adapter (HBA). Other servers in this enclosed system include a power card. This section describes the supported power card for the 826 back-plane system.

For more information, see the PCC-JBPWR2 power card manual. This manual can be found at the <http://www.supermicro.com> or as an appendix in the SC826 chassis manual.

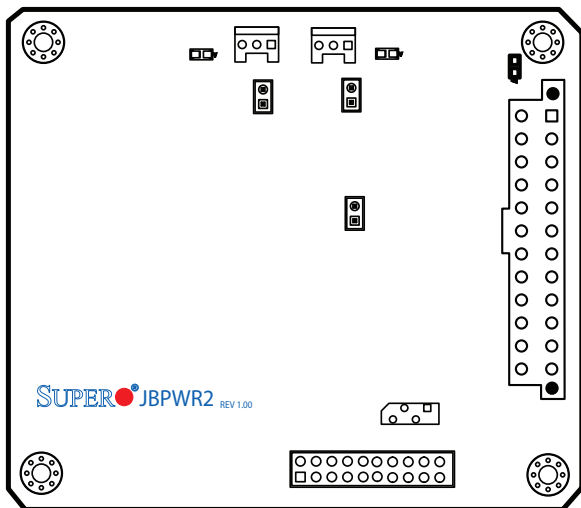

Power Card		
Part Number	Part Type	Where Used
CSE-PTJBOD-CB1	Power Card	Allows the chassis to be in a JBOD (Just a Bunch of Drives) system.

Connecting an Internal Host Bus Adapter to the Backplane

The following section lists the most common cables used to connect the HBA to the backplane.

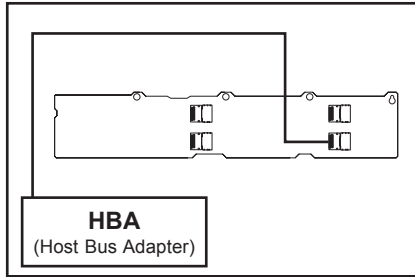

Single Internal Host Bus Adapter

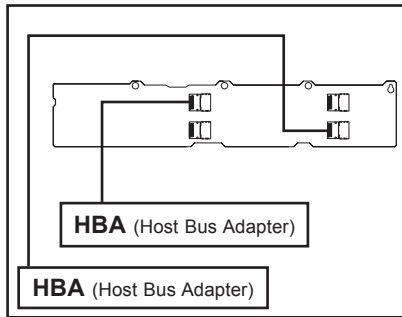

Dual Internal Host Bus Adapter

Supported Internal HBA to Backplane Cables

Use the following listed cables to create connections between the internal HBA and backplane. The cables required depend on the HBA connector.

Cable Name: IPASS TO 4-LANE

Part #: CBL-0117

Length: 46 cm (18 inches)

Description: This cable has one SFF-8484 (32 pin) connector on one end and ipass (SFF-8087/mini-sas) connector (36 pins) at the other. This cable connects from the HBA to the 826 EL backplane.

Cable Name: SFF-8087 (mini SAS) TO SFF-8087 (mini SAS)

Part #: CBL-0108L-02 **Length:** 39 cm (15 inches)

Part #: CBL-0109L-02 **Length:** 22 cm (9 inches)

Part #: CBL-0110L-02 **Length:** 18 cm (7 inches)

Description: This cable has an ipass (SFF-8087/mini-sas) connector (36 pins) at each end. It connects from the HBA to the 826 EL backplane.

Connecting an External Host Bus Adapter to the Backplane

This backplane supports external Host Bus Adapters. In this configuration, the HBA and the backplane are in different physical chassis. This allows a JBOD (Just a Bunch Of Drives) configuration from an existing system.

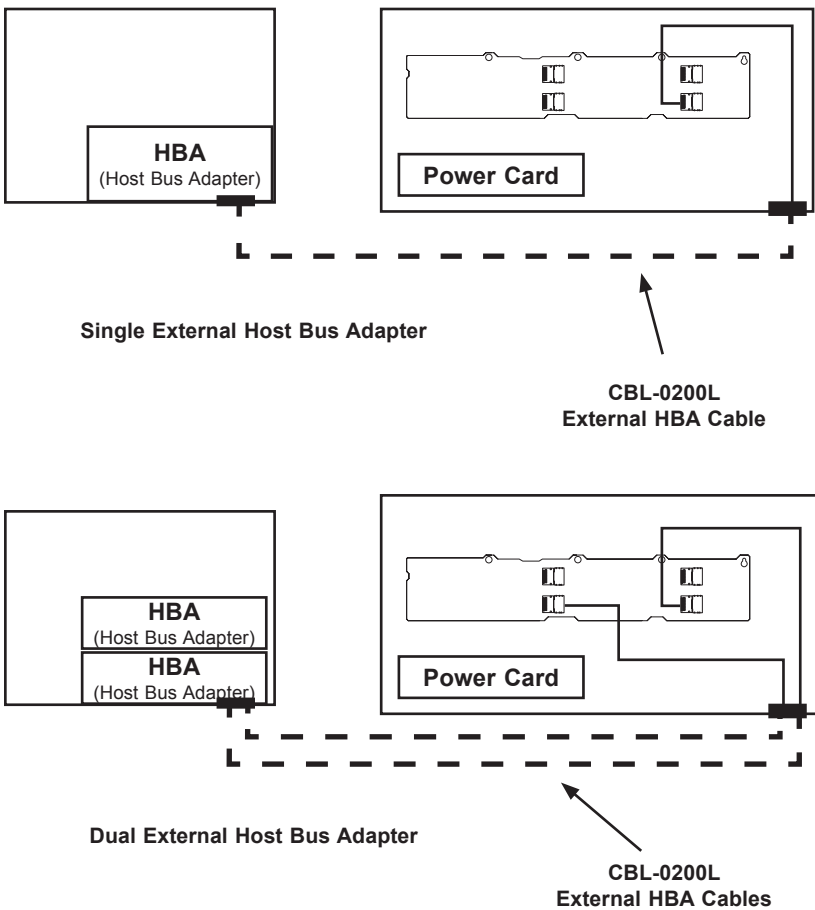

Supported External HBA to Backplane Cable

Use the following cable if your external HBA has an Infiniband connector.



Cable Name: SAS InfiniBand to Mini SAS X4 1M cable, PBF

Part #: CBL-0200L

Length: 1 meter

Description: This cable has an Infiniband connector (SFF-8470) on one end and an SFF-8088-1X (26-pins) at the other end.

Connecting Multiple Backplanes in a Single Channel Environment

This section describes the cables used when cascading from a single HBA. These connections use CBL-0167L internal cables and CBL-0166L external cables.

Single HBA Configuration

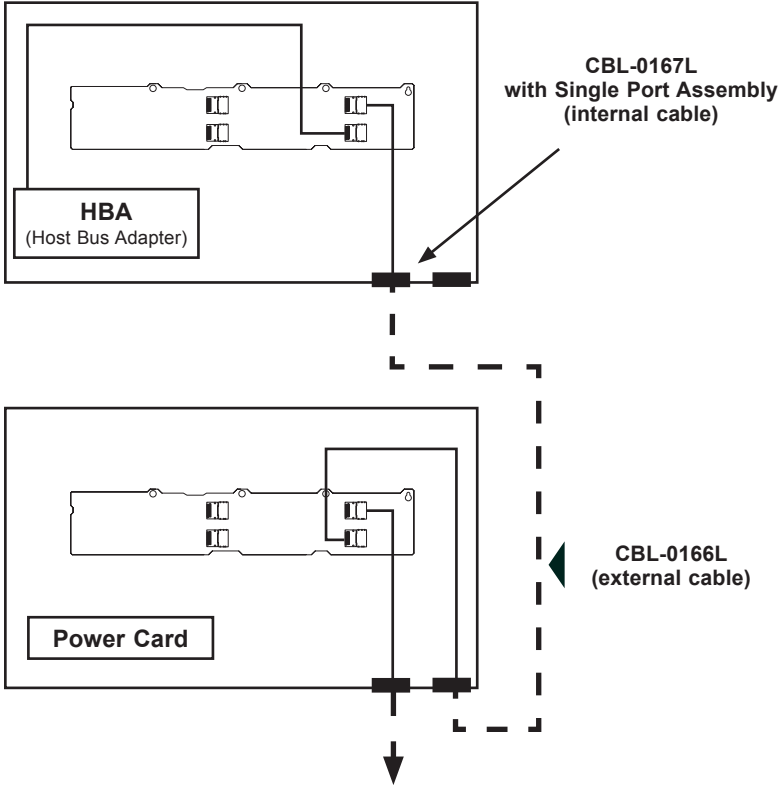

Single HBA Configuration Cables

Single Port Cable Assembly

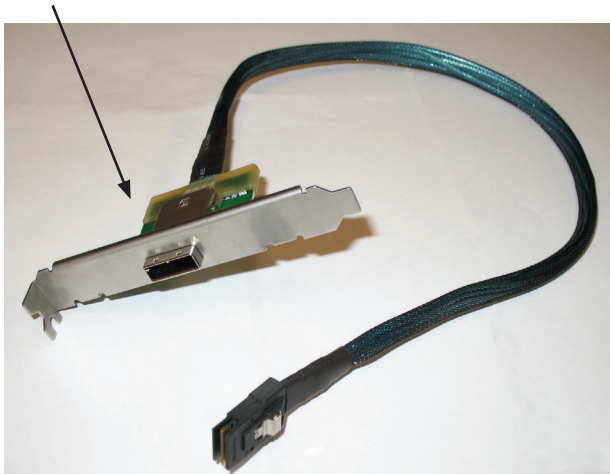

Cable Name: SAS EL2/EL1 Backplane Cable (Internal) w/ 2-port Cascading Cable, 68 cm

Part #: CBL-0167L (SFF-8087 to SFF-8088 x1)

Ports: Single

Placement: Internal cable

Description: Internal cable. Connects the backplane to the Host Bus Adapter (HBA) or external port. Used in single port environments.



Cable Name: SAS EL2/EL1 Cascading Cable (External), 68cm

Part #: CBL-0166L (SFF-8088 1x to SFF-8088 x1)

Ports: Single or Dual

Placement: External cable

Description: External cascading cable. Connects ports between servers. With most connectors, use one cable for single port connections and two cables for dual port connections.

Connecting Multiple Backplanes in a Dual Channel Environment

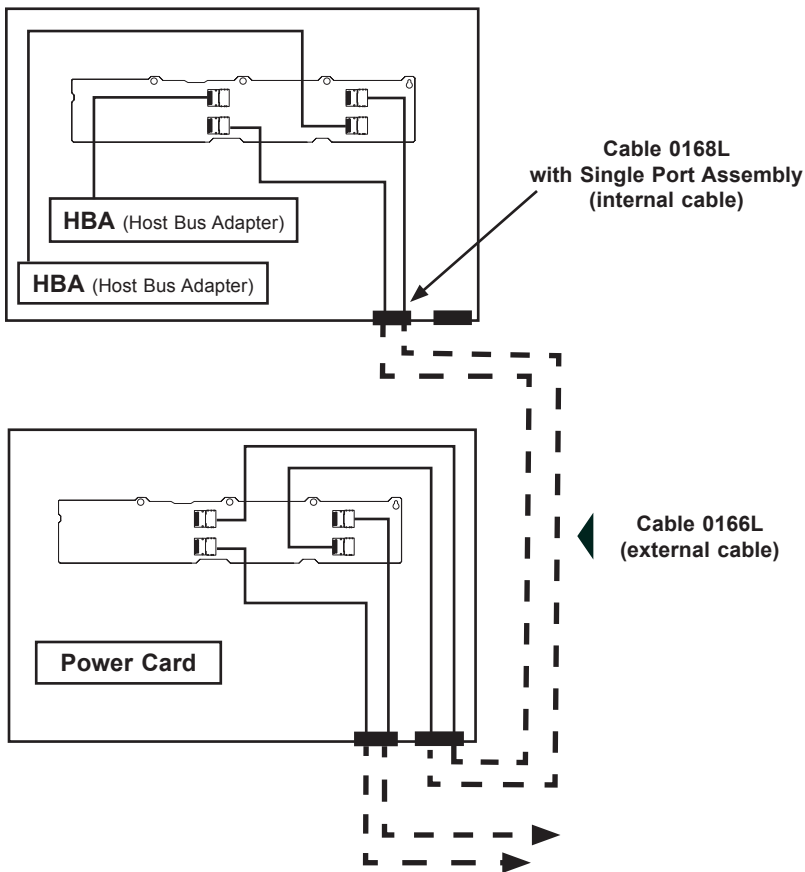

Dual HBA Configuration Cables

Dual Port Cable Assembly



Cable Name: SAS Dual-port Cable Assembly, 68/76cm

Part #: CBL-0168L (SFF-8087 to SFF-8088 x2)

Ports: Dual

Placement: Internal cable

Description: Internal cascading cable. Connects the backplane to the Host Bus Adapter (HBA) or external port. Used in Dual port environments.



Cable Name: SAS EL2/EL1 Cascading Cable (External), 68cm

Part #: CBL-0166L (SFF-8088 x1 to SFF-8088 x1)

Ports: Single or Dual

Placement: External cable

Description: External cascading cable. Connects ports between servers. Use one cable for single port connections and two cables for dual port connections.

D-11 Supported Cascading Configuration

Cascading allows the system to access data at a faster rate by allowing several backplanes to share resources to reduce latency time.

The first backplane in a cascaded system requires a motherboard and HBA. Other servers require a power control card, not a motherboard and HBA. For more information, see the 826 Chassis Manual.

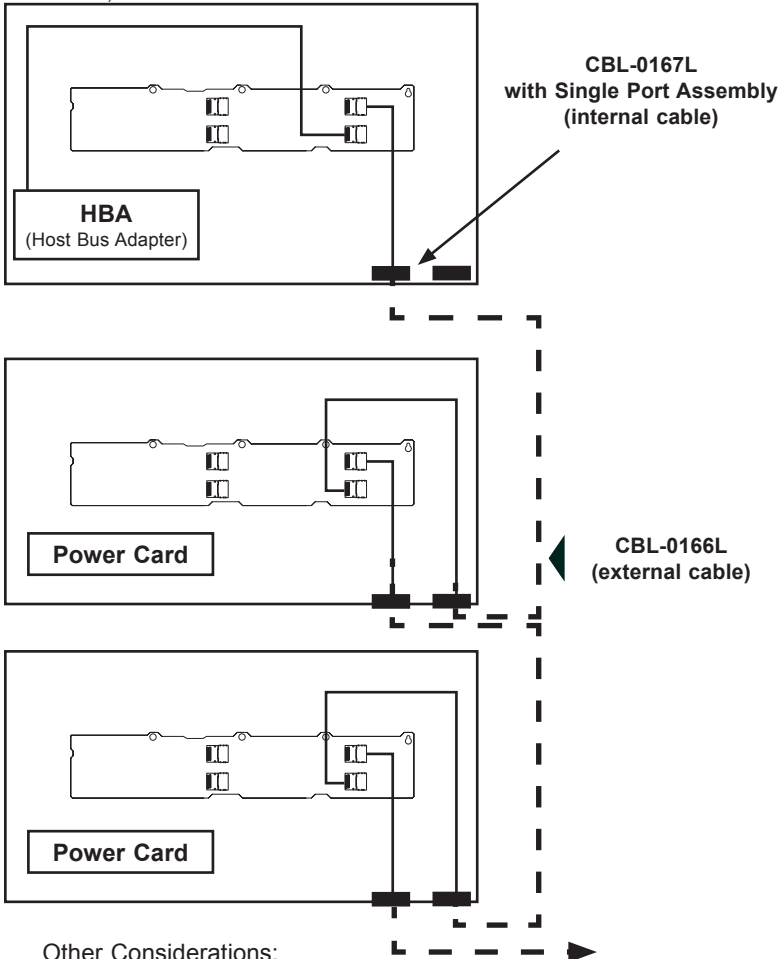

Other Considerations:

- Cascading supports up to 122 hard drives
- Use the same cables for all single port configurations
- See page 3-4 if your HBA is external to your backplane.

Server System with Dual SAS HBA and Cascading C.onfiguration

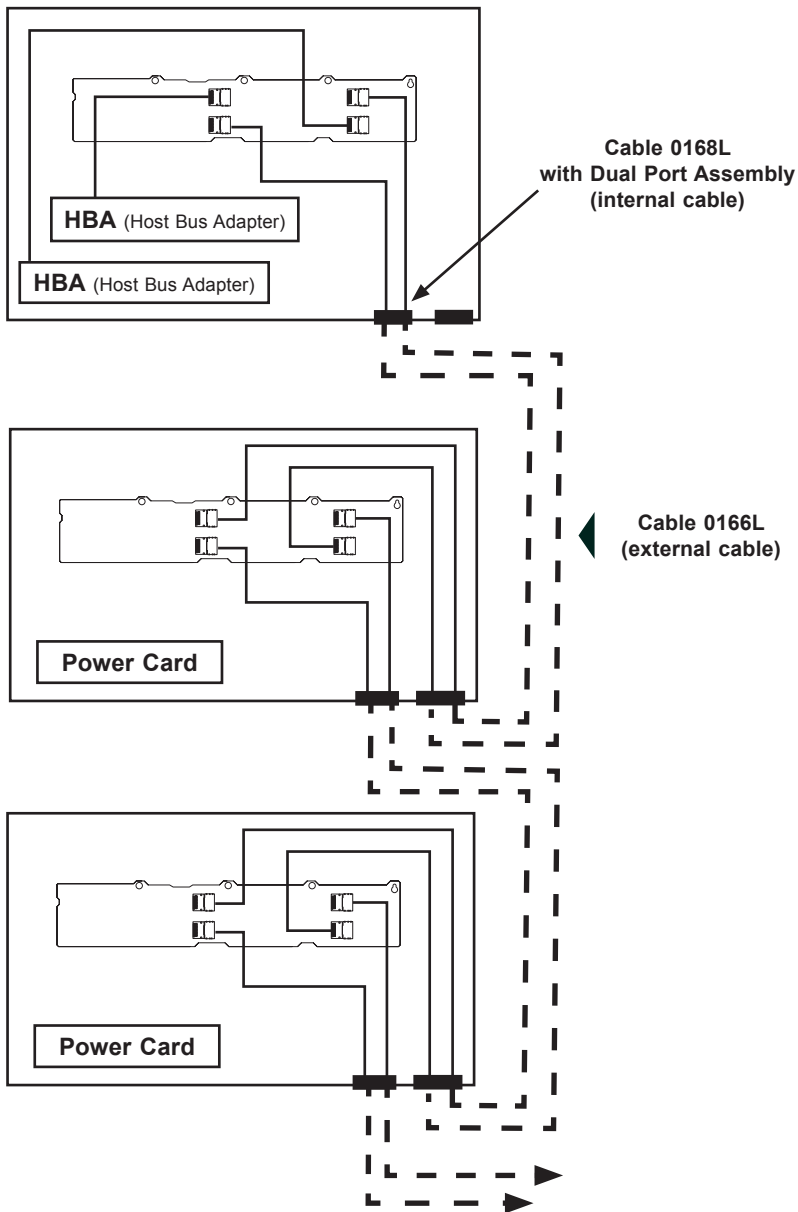

Notes