

# SUPERO<sup>®</sup>

SUPERSERVER  
6018R-WTR  
6018R-WTRT

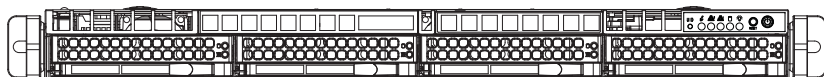

## USER'S MANUAL

Revision 1.0

The information in this User's Manual has been carefully reviewed and is believed to be accurate. The vendor assumes no responsibility for any inaccuracies that may be contained in this document, makes no commitment to update or to keep current the information in this manual, or to notify any person or organization of the updates. **Please Note: For the most up-to-date version of this manual, please see our web site at [www.supermicro.com](http://www.supermicro.com).**

Super Micro Computer, Inc. ("Supermicro") reserves the right to make changes to the product described in this manual at any time and without notice. This product, including software and documentation, is the property of Supermicro and/or its licensors, and is supplied only under a license. Any use or reproduction of this product is not allowed, except as expressly permitted by the terms of said license.

IN NO EVENT WILL SUPERMICRO BE LIABLE FOR DIRECT, INDIRECT, SPECIAL, INCIDENTAL, SPECULATIVE OR CONSEQUENTIAL DAMAGES ARISING FROM THE USE OR INABILITY TO USE THIS PRODUCT OR DOCUMENTATION, EVEN IF ADVISED OF THE POSSIBILITY OF SUCH DAMAGES. IN PARTICULAR, SUPERMICRO SHALL NOT HAVE LIABILITY FOR ANY HARDWARE, SOFTWARE, OR DATA STORED OR USED WITH THE PRODUCT, INCLUDING THE COSTS OF REPAIRING, REPLACING, INTEGRATING, INSTALLING OR RECOVERING SUCH HARDWARE, SOFTWARE, OR DATA.

Any disputes arising between manufacturer and customer shall be governed by the laws of Santa Clara County in the State of California, USA. The State of California, County of Santa Clara shall be the exclusive venue for the resolution of any such disputes. Super Micro's total liability for all claims will not exceed the price paid for the hardware product.

FCC Statement: This equipment has been tested and found to comply with the limits for a Class A digital device pursuant to Part 15 of the FCC Rules. These limits are designed to provide reasonable protection against harmful interference when the equipment is operated in a commercial environment. This equipment generates, uses, and can radiate radio frequency energy and, if not installed and used in accordance with the manufacturer's instruction manual, may cause harmful interference with radio communications. Operation of this equipment in a residential area is likely to cause harmful interference, in which case you will be required to correct the interference at your own expense.

California Best Management Practices Regulations for Perchlorate Materials: This Perchlorate warning applies only to products containing CR (Manganese Dioxide) Lithium coin cells. "Perchlorate Material-special handling may apply. See [www.dtsc.ca.gov/hazardouswaste/perchlorate](http://www.dtsc.ca.gov/hazardouswaste/perchlorate)"

**WARNING: Handling of lead solder materials used in this product may expose you to lead, a chemical known to the State of California to cause birth defects and other reproductive harm.**

Manual Revision 1.0

Release Date: August 14, 2014

Unless you request and receive written permission from Super Micro Computer, Inc., you may not copy any part of this document.

Information in this document is subject to change without notice. Other products and companies referred to herein are trademarks or registered trademarks of their respective companies or mark holders.

Copyright © 2014 by Super Micro Computer, Inc.

All rights reserved.

**Printed in the United States of America**

# Preface

## About This Manual

This manual is written for professional system integrators and PC technicians. It provides information for the installation and use of the SuperServer 6018R-WTR(T). Installation and maintenance should be performed by experienced technicians only.

The SuperServer 6018R-WTR(T) is a 1U rackmount server based on the SC815TQ-R706WB server chassis and the X10DRW-i(T) serverboard. The SuperServer 6018R-WTR(T) system's WIO platform has major advantages over E-ATX/ATX platforms in small form factor 1U and 2U systems by increasing I/O performance by use of multiple full-height, full-length add-on cards. Please refer to our web site for updates on supported processors.

The only difference between the 6018R-WTR and 6018R-WTRT servers is that the 6018R-WTR use 1Gps dual LAN ports and the 6018R-WTRT uses 10Gps dual LAN ports.

## Manual Organization

### Chapter 1: Introduction

The first chapter provides a checklist of the main components included with the server system and describes the main features of the X10DRW-i(T) serverboard and the SC815TQ-R706WB chassis.

### Chapter 2: Server Installation

This chapter describes the steps necessary to install the SuperServer 6018R-WTR(T) into a rack and check out the server configuration prior to powering up the system. If your server was ordered without the processor and memory components, this chapter will refer you to the appropriate sections of the manual for their installation.

### Chapter 3: System Interface

Refer to this chapter for details on the system interface, which includes the functions and information provided by the control panel on the chassis as well as other LEDs located throughout the system.

### Chapter 4: Standardized Warning Statements for AC Systems

You should thoroughly familiarize yourself with this chapter for a general overview of safety precautions that should be followed when installing and servicing the SuperServer 6018R-WTR(T).

### **Chapter 5: Advanced Serverboard Setup**

This chapter provides detailed information on the X10DRW-i(T) serverboard, including the locations and functions of connectors, headers and jumpers. Refer to this chapter when adding or removing processors or main memory and when reconfiguring the serverboard.

### **Chapter 6: Advanced Chassis Setup**

Refer to Chapter 6 for detailed information on the SC815TQ-R706WB chassis. You should follow the procedures given in this chapter when installing, removing or reconfiguring Serial ATA or peripheral drives and when replacing system power supply units and cooling fans.

### **Chapter 7: BIOS**

The BIOS chapter includes an introduction to BIOS and provides detailed information on running the CMOS Setup Utility.

### **Appendix A: BIOS POST Error Codes**

### **Appendix B: Installing Windows**

### **Appendix C: System Specifications**



## Notes

---

---

## Table of Contents

### **Chapter 1 Introduction**

1-1	Overview .....	1-1
1-2	Serverboard Features .....	1-2
	Processors .....	1-2
	Memory .....	1-2
	SAS/SATA.....	1-2
	PCI Expansion Slots .....	1-3
	Rear I/O Ports .....	1-3
1-3	Server Chassis Features .....	1-3
	System Power .....	1-3
	Hard Drive Subsystem .....	1-3
	PCI Expansion Slots .....	1-3
	Front Control Panel.....	1-4
	I/O Backplane.....	1-4
	Cooling System .....	1-4
1-4	Advanced Power Management .....	1-4
	Intel® Intelligent Power Node Manager (NM).....	1-4
	Manageability Engine (ME).....	1-4
1-5	Contacting Supermicro.....	1-6

### **Chapter 2 Server Installation**

2-1	Overview .....	2-1
2-2	Unpacking the System .....	2-1
2-3	Preparing for Setup.....	2-1
	Choosing a Setup Location.....	2-2
2-4	Warnings and Precautions .....	2-2
	Rack Precautions .....	2-2
	Server Precautions.....	2-2
	Rack Mounting Considerations .....	2-3
	Ambient Operating Temperature .....	2-3
	Reduced Airflow .....	2-3
	Mechanical Loading .....	2-3
	Circuit Overloading.....	2-4
	Reliable Ground .....	2-4
2-5	Installing the System into a Rack .....	2-5
	Identifying the Sections of the Rack Rails.....	2-5
	Installing the Inner Rails .....	2-5

---

---

	Installing the Outer Rails.....	2-6
	Installing the Server into the Rack.....	2-7
2-6	Checking the Serverboard Setup.....	2-8
2-7	Checking the Drive Bay Setup.....	2-9

### **Chapter 3 System Interface**

3-1	Overview .....	3-1
3-2	Control Panel Buttons .....	3-2
	Reset .....	3-2
	Power .....	3-2
	UID .....	3-2
3-3	Control Panel LEDs .....	3-3
	Information LED .....	3-3
	NIC2 .....	3-3
	NIC1 .....	3-3
	HDD.....	3-3
	Power .....	3-4
3-4	Hard Drive Carrier LEDs.....	3-4

### **Chapter 4 Standardized Warning Statements for AC Systems**

4-1	About Standardized Warning Statements.....	4-1
	Warning Definition .....	4-1
	Installation Instructions.....	4-4
	Circuit Breaker .....	4-5
	Power Disconnection Warning .....	4-6
	Equipment Installation.....	4-8
	Restricted Area.....	4-9
	Battery Handling.....	4-10
	Redundant Power Supplies .....	4-12
	Backplane Voltage .....	4-13
	Comply with Local and National Electrical Codes .....	4-14
	Product Disposal .....	4-15
	Easy Swap Fan Warning .....	4-16
	Power Cable and AC Adapter .....	4-18

**Chapter 5 Advanced Serverboard Setup**

5-1	Handling the Serverboard .....	5-1
	Precautions .....	5-1
	Unpacking .....	5-1
5-2	Connecting Cables .....	5-2
	Connecting Data Cables .....	5-2
	Connecting Power Cables .....	5-2
	Connecting the Control Panel.....	5-3
5-3	Rear I/O Ports .....	5-4
5-4	Installing the Processor and Heatsink .....	5-5
	Installing an LGA 2011 Processor.....	5-5
	Installing and Removing a Passive CPU Heatsink.....	5-8
5-5	Installing Memory .....	5-9
	Memory Support.....	5-9
	DIMM Installation .....	5-9
5-4	Serverboard Details .....	5-12
5-7	Connector Definitions .....	5-15
	Power Connectors .....	5-15
	Power Button .....	5-15
	Reset Button .....	5-16
	Power Fail LED .....	5-16
	Overheat (OH)/Fan Fail/PWR Fail/UID LED.....	5-16
	NIC1/NIC2 LED Indicators .....	5-16
	HDD/UID LED .....	5-16
	Power LED .....	5-17
	NMI Button .....	5-17
	Ethernet Ports .....	5-17
	Chassis Intrusion .....	5-17
	Video Connection .....	5-17
	Universal Serial Bus (USB).....	5-18
	TPM/Port 80 Header .....	5-18
	Unit Identifier Switch/UID LED Indicator .....	5-19
	Internal Speaker .....	5-19
	Standby Power Header .....	5-19
	Power SMB (I <sup>2</sup> C) Connector .....	5-20
	IPMB.....	5-20
	Fan Headers.....	5-20
	S-SGPIO and I-SGPIO 1/2 Headers.....	5-20

---

---

5-8	Jumper Settings .....	5-21
	Explanation of Jumpers .....	5-21
	CMOS Clear .....	5-21
	LAN Enable/Disable .....	5-22
	Watch Dog Enable/Disable .....	5-22
	VGA Enable .....	5-22
	BMC Enable .....	5-22
	I <sup>2</sup> C Bus to PCI-E Slots .....	5-23
	Manufacturer Mode Select .....	5-23
5-9	Onboard LED Indicators .....	5-24
	GLAN LEDs .....	5-24
	IPMI Dedicated LAN LEDs .....	5-24
	BMC Heartbeat LED .....	5-24
	Onboard Power LED .....	5-25
5-10	SATA Connections .....	5-25
	SATA 3.0 Ports .....	5-25
5-11	Installing Software .....	5-26
	SuperDoctor 5 .....	5-27
5-12	Serverboard Battery .....	5-29
<b><i>Chapter 6 Advanced Chassis Setup</i></b>		
6-1	Static-Sensitive Devices .....	6-1
	Precautions .....	6-1
6-2	Control Panel .....	6-2
6-3	System Fans .....	6-2
	System Fan Failure .....	6-3
6-4	Drive Bay Installation/Removal .....	6-4
	Removing the Front Bezel .....	6-4
	Accessing the Drive Bays .....	6-4
	Hard Drive Installation .....	6-5
	DVD-ROM Drive Installation .....	6-6
6-5	Power Supply .....	6-7
	Redundant Power Supply Failure .....	6-7

**Chapter 7 BIOS**

7-1	Introduction.....	7-1
	Starting BIOS Setup Utility.....	7-1
	How To Change the Configuration Data.....	7-2
	Starting the Setup Utility.....	7-2
7-2	Main Setup.....	7-2
7-3	Advanced Setup Configurations.....	7-3
7-4	Event Logs.....	7-23
7-5	IPMI.....	7-25
7-6	Boot.....	7-27
7-7	Security.....	7-28
7-8	Save & Exit.....	7-29

**Appendix A BIOS Error Beep Codes**

**Appendix B System Specifications**

# Chapter 1

## Introduction

### 1-1 Overview

The SuperServer 6018R-WTR(T) is a high-end server comprised of two main subsystems: the SC815TQ-R706WB 1U server chassis and the X10DRW-i(T) dual processor serverboard. Please refer to our web site for information on operating systems that have been certified for use with the system ([www.supermicro.com](http://www.supermicro.com)).

In addition to the serverboard and chassis, various hardware components have been included with the SuperServer 6018R-WTR(T) as listed below:

- One (1) SC815/113/116 Intel DP X9, X8 PC air shroud (MCP-310-19002-0N)
- One (1) 70-cm round 20-to-20-pin Front Panel Control Cable (CBL-0335L)
- Heatsinks:
  - One (1) 1U Passive CPU Heatsinks (SNK-P0047PSC OR SNK-P0057PSC)
  - One (1) 1U Passive CPU Heatsinks (SNK-P0057PS)
- Fans:
  - Four (4) 40x56mm 4-pin PWM chassis middle fans (FAN-0086L4)
  - One (1) 40x56mm 4-pin PWM chassis middle fan (MCP-340-00022-0N)
- IDE Accessories
  - One (1) Mini-IDE to IDE adapter for optional DVD (MCP-420-81501-IN)
  - One (1) 50-cm IDE 80-wire cable for DVD ROM, 30AWG cable (CBL-0139L)
  - One (1) 8-cm FDD DVD 4-pin power adapter cable 24AWG (CBL-0210L)
- SATA Accessories
  - One (1) HD backplane (BPN-SAS-815TQ-O-P)
  - One (1) 40-cm 8-pin to 8-pin round 28AWG cable (CBL-CDAT-0661)
  - One (1) set of 4 SATA 56/45.5/35/23-cm round 26AWG cable (CBL-0186L)
  - Four (4) hot-swap 3.5" hard-disk drive trays (MCP-220-00075-0B)
- One (1) riser card (RSC-R1UW-2E16-O-P)
- One (1) rail set for 1U (MCP-290-00054-0N)

**Note:** For your system to work properly, please follow the links below to download all necessary drivers/utilities and the user's manual for your server.

- Supermicro product manuals: <http://www.supermicro.com/support/manuals/>
- Product drivers and utilities: <ftp://ftp.supermicro.com>
- Product safety information:  
[http://super-dev/about/policies/safety\\_information.cfm](http://super-dev/about/policies/safety_information.cfm)
- If you have any questions, please contact our support team at:  
[support@supermicro.com](mailto:support@supermicro.com)

## 1-2 Serverboard Features

The SuperServer 6018R-WTR(T) is built around the X10DRW-i(T), a dual processor serverboard based on the Intel PCH-C612 chipset and designed to provide maximum performance. Below are the main features of the X10DRW-i(T). (See Figure 1-1 for a block diagram of the chipset.)

### Processors

The X10DRW-i(T) supports single or dual Intel® Xeon E5-2600v3 Series processors. Please refer to the serverboard description pages on our web site for a complete listing of supported processors ([www.supermicro.com](http://www.supermicro.com)).

### Memory

The X10DRW-i(T) has sixteen (16) DIMM slots that can support up to 1024 GB of ECC RDIMM or LRDIMM DDR4 2133/1866/1600/1333 MHz speed memory in 1 GB, 2 GB, 4 GB, 8 GB, 16 GB, 32 GB and 64 GB size @ 1.2V voltage. See Chapter 5 for details.

**Note:** For the latest CPU/memory updates, please refer to our website at <http://www.supermicro.com/products/serverboard>.

### SAS/SATA

A SATA controller is also integrated into the chipset to provide up to ten SATA 3.0 (6/Gbps) ports, which are RAID 0, 1, 5, 10 supported. The SATA drives are hot-swappable units.

The BPN-SAS-815TQ SAS/SATA backplane can support SAS devices with a SAS RAID/HBA add-on card (not included in the SuperServer 6018R-WTR(T)).

**Note:** The operating system you use must have RAID support to enable the hot-swap capability and RAID function of the SATA drives.



## PCI Expansion Slots

The X10DRW-i(T) has one (1) SMC-proprietary PCI-E 3.0 x16 slot, one (1) SMC-proprietary PCI-E 3.0 x16+x16 slot, and one (1) PCI-E 3.0 x16 Add-On-Module (AOM) slot for a mezzanine HBA card. PCI slots are controlled by CPUs: both CPUs must be installed to utilize all slots. See Chapter 5 for details.

## Rear I/O Ports

Ports on the I/O backplane include one COM port, a VGA port, four USB 2.0 ports, two gigabit (6018R-WTR) or 10-gigabit (6018R-WTRT) Ethernet ports and one IPMI port. A UID (Unit Identifier) button and LED are also located beside the VGA port.

## 1-3 Server Chassis Features

The SuperServer 6018R-WTR(T) is built upon the SC815TQ-R706WB chassis. Details on the chassis and on servicing procedures can be found in Chapter 6. The following is a general outline of the main features of both chassis.

### System Power

The SC815TQ-R706WB features both a primary and redundant 700/750 Watt power supply (Part# PWS-706P-1R). The system does not need to be shut down when replacing or removing a single power supply module.

**Note:** The power supplies are both redundant, hot-plug.

### Hard Drive Subsystem

The SC815TQ-R706WB chassis was designed to support four 3.5" hot-swap SATA hard drives. With a conversion kit (P/N: MCP-220-00043-0N) you can support 2.5" drives.

**Note:** For the 6018R-WTR, the hard drives are connected to four onboard SATA connections from the SCU Controller.

### PCI Expansion Slots

A riser card (RSC-R1UW-2E16-O-P) on the left side of the chassis can support two PCI-E x16 add-on cards. See our web site for details (<http://www.supermicro.com/products/info/UIO.cfm>). See section 5-6 for further details.

## Front Control Panel

The chassis' control panel provides you with system monitoring and control. LEDs indicate system power, HDD activity, network activity (two) and UID/overheat/fan fail/power fail. A main power button, a system reset button and a UID button are also included.

## I/O Backplane

The SC815TQ-R706WB is an extended ATX form factor chassis that is designed to be used in a 1U rackmount configuration. Ports on the I/O backplane include one COM port, a VGA port, four USB 2.0 ports, two gigabit LAN Ethernet ports and one dedicated IPMI LAN port. A UID (Unit Identifier) button and LED are also located beside the VGA port.

## Cooling System

The SC815TQ-R706WB chassis has an innovative cooling design that features five (5) sets of 4-cm counter-rotating fans located in the middle section of the chassis. There is a "Fan Speed Control Mode" setting in IPMI that allows chassis fan speed to be determined by system temperature. The power supply module also includes a cooling fan.

**Note:** The fans in this system are NOT redundant, hot-plug.

# 1-4 Advanced Power Management

## Intel® Intelligent Power Node Manager (NM)

The Intel® Intelligent Power Node Manager (IPNM) provides your system with real-time thermal control and power management for maximum energy efficiency. Although IPNM Specification Version 1.5 is supported by the BMC (Baseboard Management Controller), your system must also have IPNM-compatible Manageability Engine (ME) firmware installed to use this feature.

## Manageability Engine (ME)

The Manageability Engine, which is an ARC controller embedded in the IOH (I/O Hub), provides Server Platform Services (SPS) to your system. The services provided by SPS are different from those provided by the ME on client platforms.

**Figure 1-1. Intel PCH-C612 Chipset:  
System Block Diagram**

Note: This is a general block diagram. Please see Chapter 5 for details.

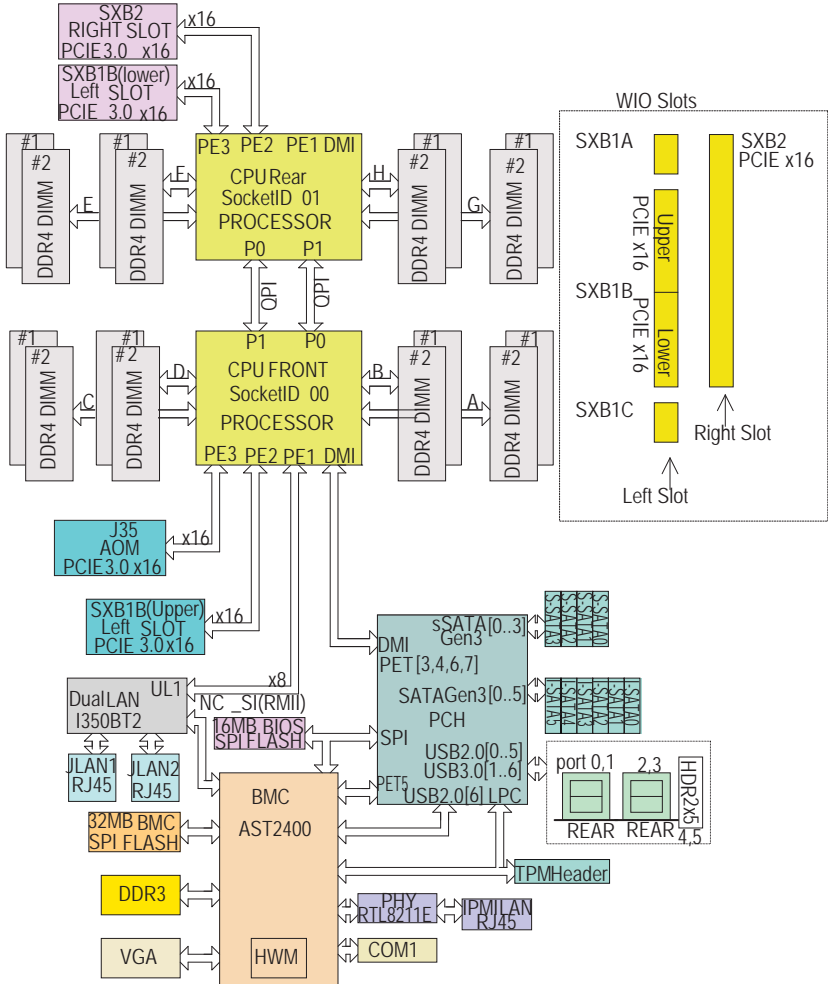

## 1-5 Contacting Supermicro

### Headquarters

Address: Super Micro Computer, Inc.  
980 Rock Ave.  
San Jose, CA 95131 U.S.A.

Tel: +1 (408) 503-8000

Fax: +1 (408) 503-8008

Email: [marketing@supermicro.com](mailto:marketing@supermicro.com) (General Information)  
[support@supermicro.com](mailto:support@supermicro.com) (Technical Support)

Web Site: [www.supermicro.com](http://www.supermicro.com)

### Europe

Address: Super Micro Computer B.V.  
Het Sterrenbeeld 28, 5215 ML  
's-Hertogenbosch, The Netherlands

Tel: +31 (0) 73-6400390

Fax: +31 (0) 73-6416525

Email: [sales@supermicro.nl](mailto:sales@supermicro.nl) (General Information)  
[support@supermicro.nl](mailto:support@supermicro.nl) (Technical Support)  
[rma@supermicro.nl](mailto:rma@supermicro.nl) (Customer Support)

Web Site: [www.supermicro.nl](http://www.supermicro.nl)

### Asia-Pacific

Address: Super Micro Computer, Inc.  
3F, No. 150, Jian 1st Rd.  
Zhonghe Dist., New Taipei City 235  
Taiwan (R.O.C)

Tel: +886-(2) 8226-3990

Fax: +886-(2) 8226-3992

Email: [support@supermicro.com.tw](mailto:support@supermicro.com.tw)

Web Site: [www.supermicro.com.tw](http://www.supermicro.com.tw)

## Chapter 2

# Server Installation

### 2-1 Overview

This chapter provides a quick setup checklist to get your SuperServer 6018R-WTR(T) up and running. Following these steps in the order given should enable you to have the system operational within a minimum amount of time. This quick setup assumes that your system has come to you with the processors and memory preinstalled. If your system is not already fully integrated with a serverboard, processors, system memory etc., please turn to the chapter or section noted in each step for details on installing specific components.

### 2-2 Unpacking the System

You should inspect the box the SuperServer 6018R-WTR(T) was shipped in and note if it was damaged in any way. If the server itself shows damage you should file a damage claim with the carrier who delivered it.

Decide on a suitable location for the rack unit that will hold the SuperServer 6018R-WTR(T). It should be situated in a clean, dust-free area that is well ventilated. Avoid areas where heat, electrical noise and electromagnetic fields are generated. You will also need it placed near a grounded power outlet. Be sure to read the Rack and Server Precautions in the next section.

### 2-3 Preparing for Setup

The box the SuperServer 6018R-WTR(T) was shipped in should include two sets of rail assemblies, two rail mounting brackets and the mounting screws you will need to install the system into the rack. Follow the steps in the order given to complete the installation process in a minimum amount of time. Please read this section in its entirety before you begin the installation procedure outlined in the sections that follow.

## Choosing a Setup Location

- Leave enough clearance in front of the rack to enable you to open the front door completely (~25 inches) and approximately 30 inches of clearance in the back of the rack to allow for sufficient airflow and ease in servicing. This product is for installation only in a Restricted Access Location (dedicated equipment rooms, service closets and the like).
- This product is not suitable for use with visual display work place devices according to §2 of the the German Ordinance for Work with Visual Display Units.

## 2-4 Warnings and Precautions



**Warning!** To prevent bodily injury when mounting or servicing this unit in a rack, you must take special precautions to ensure that the system remains stable. The following guidelines are provided to ensure your safety:

- This unit should be mounted at the bottom of the rack if it is the only unit in the rack.
- When mounting this unit in a partially filled rack, load the rack from the bottom to the top with the heaviest component at the bottom of the rack.
- If the rack is provided with stabilizing devices, install the stabilizers before mounting or servicing the unit in the rack.

### Rack Precautions

- Ensure that the leveling jacks on the bottom of the rack are fully extended to the floor with the full weight of the rack resting on them.
- In single rack installation, stabilizers should be attached to the rack. In multiple rack installations, the racks should be coupled together.
- Always make sure the rack is stable before extending a component from the rack.
- You should extend only one component at a time - extending two or more simultaneously may cause the rack to become unstable.

### Server Precautions

- Review the electrical and general safety precautions in Chapter 4.
- Determine the placement of each component in the rack *before* you install the rails.

- Install the heaviest server components on the bottom of the rack first, and then work up.
- Use a regulating uninterruptible power supply (UPS) to protect the server from power surges, voltage spikes and to keep your system operating in case of a power failure.
- Allow the hot plug SATA drives and power supply modules to cool before touching them.
- Always keep the rack's front door and all panels and components on the servers closed when not servicing to maintain proper cooling.

## **Rack Mounting Considerations**



**Warning:** Do not pick up the server with the front handles. They are designed to pull the system from a rack only.



**Stability Hazard:** The rack stabilizing mechanism must be in place, or the rack must be bolted to the floor before you slide the unit out for servicing. Failure to stabilize the rack can cause the rack to tip over.

### ***Ambient Operating Temperature***

If installed in a closed or multi-unit rack assembly, the ambient operating temperature of the rack environment may be greater than the ambient temperature of the room. Therefore, consideration should be given to installing the equipment in an environment compatible with the manufacturer's maximum rated ambient temperature (T<sub>mra</sub>).

### ***Reduced Airflow***

Equipment should be mounted into a rack so that the amount of airflow required for safe operation is not compromised.

### ***Mechanical Loading***

Equipment should be mounted into a rack so that a hazardous condition does not arise due to uneven mechanical loading.

### ***Circuit Overloading***

Consideration should be given to the connection of the equipment to the power supply circuitry and the effect that any possible overloading of circuits might have on overcurrent protection and power supply wiring. Appropriate consideration of equipment nameplate ratings should be used when addressing this concern.

### ***Reliable Ground***

A reliable ground must be maintained at all times. To ensure this, the rack itself should be grounded. Particular attention should be given to power supply connections other than the direct connections to the branch circuit (i.e. the use of power strips, etc.).



## 2-5 Installing the System into a Rack

This section provides information on installing the SuperServer 6018R-WTR(T) into a rack unit with the rack rails provided. If the system has already been mounted into a rack, you can skip ahead to Sections 2-5 and 2-6.

There are a variety of rack units on the market, which may mean the assembly procedure will differ slightly. You should also refer to the installation instructions that came with the rack unit you are using.

### Identifying the Sections of the Rack Rails

You should have received two rack rail assemblies in the rack mounting kit. Each assembly consists of two sections: an inner fixed chassis rail that secures directly to the server chassis and an outer fixed rack rail that secures directly to the rack itself (see Figure 2-1). Two pairs of short brackets to be used on the front side of the outer rails are also included.

### Installing the Inner Rails

Both the left and right side inner rails have been pre-attached to the chassis. Proceed to the next step.

**Figure 2-1. Identifying the Sections of the Rack Rails  
(right side rail shown)**

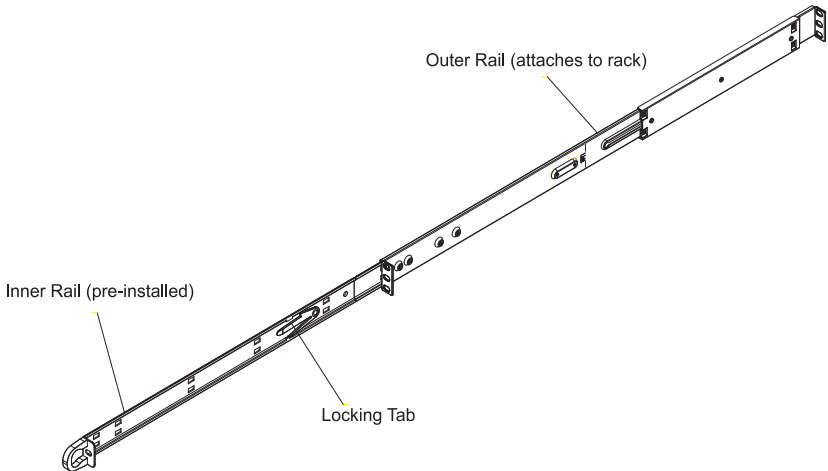

## Installing the Outer Rails

Begin by measuring the distance from the front rail to the rear rail of the rack. Attach a short bracket to the front side of the right outer rail and a long bracket to the rear side of the right outer rail. Adjust both the short and long brackets to the proper distance so that the rail can fit snugly into the rack. Secure the short bracket to the front side of the outer rail with two screws and the long bracket to the rear side of the outer rail with three screws. Repeat these steps for the left outer rail. See Figure 2-2 for details

**Locking Tabs:** Both chassis rails have a locking tab, which serves two functions. The first is to lock the server into place when installed and pushed fully into the rack, which is its normal position. Secondly, these tabs also lock the server in place when fully extended from the rack. This prevents the server from coming completely out of the rack when you pull it out for servicing.

**Figure 2-2. Installing the Rack Rails**

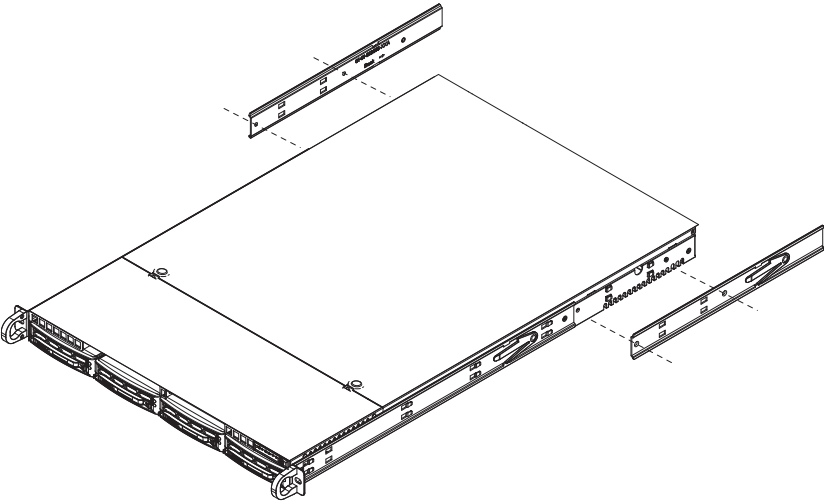

## Installing the Server into the Rack

You should now have rails attached to both the chassis and the rack unit. The next step is to install the server into the rack. Do this by lining up the rear of the chassis rails with the front of the rack rails. Slide the chassis rails into the rack rails, keeping the pressure even on both sides (you may have to depress the locking tabs when inserting). See Figure 2-3 for details.

When the server has been pushed completely into the rack, you should hear the locking tabs "click".

**Figure 2-3. Installing the Server into a Rack**

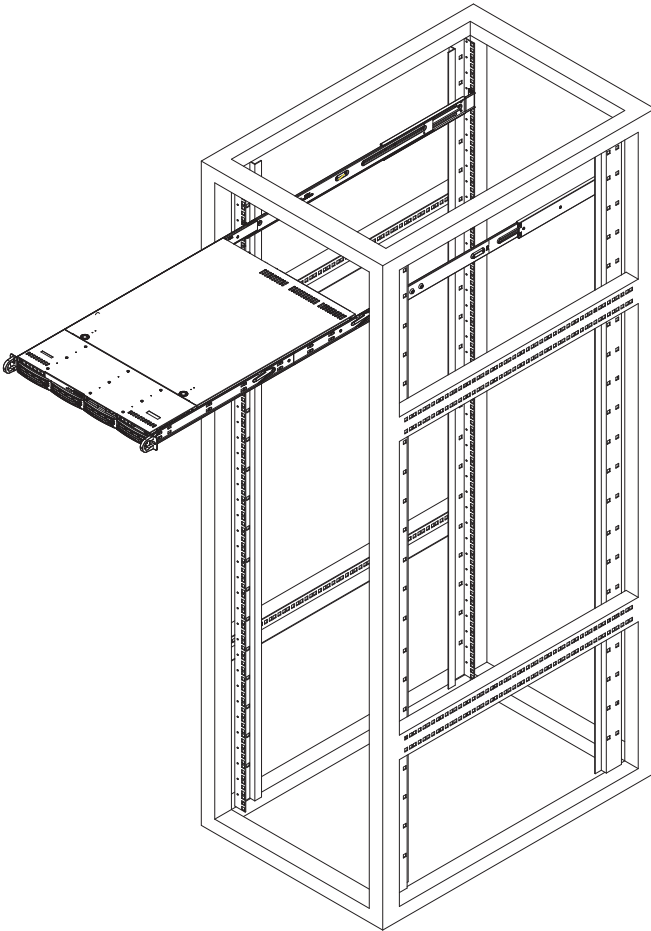

**Note:** The figure above is for illustrative purposes only. Always install servers to the bottom of the rack first.

## 2-6 Checking the Serverboard Setup

After you install the SuperServer 6018R-WTR(T) in the rack, you will need to open the top cover to make sure the serverboard is properly installed and all the connections have been made.

### ***Accessing the Inside of the System (Figure 2-5)***

1. First, grasp the two handles on either side and pull the system straight out until it locks (you will hear a "click").
2. Depress the two buttons on the top of the chassis to release the top cover (1).
3. Push the cover away from you (toward the rear of the chassis) until it stops (2). You can then lift the top cover from the chassis to gain full access to the inside of the server. See Figure 2-5.
4. To remove the system from the rack completely, depress the locking tabs in the chassis rails (push the right-side tab down and the left-side tab up) to continue to pull the system out past the locked position.

**Figure 2-5. Accessing the Inside of the System**

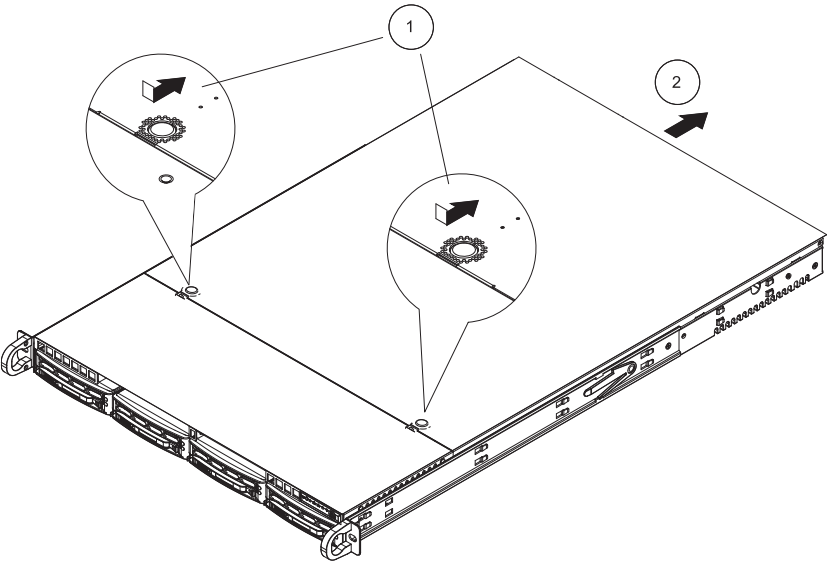

### ***Checking the Components***

1. You may have one or two processors already installed in the serverboard. Each processor needs its own heatsink. See Chapter 5 for instructions on processor and heatsink installation.
2. Your server system may have come with system memory already installed. Make sure all DIMMs are fully seated in their slots. For details on adding system memory, refer to Chapter 5.
3. If desired, you can install add-on cards to the system. See Chapter 5 for details on installing PCI add-on cards.
4. Make sure all power and data cables are properly connected and not blocking the chassis airflow. See Chapter 5 for details on cable connections.

## **2-7 Checking the Drive Bay Setup**

Next, you should check to make sure the peripheral drives and the SATA drives and SATA backplane have been properly installed and all connections have been made.

### ***Checking the Drives***

1. All drives are accessible from the front of the server. The SATA disk drives can be installed and removed from the front of the chassis without removing the top chassis cover.
2. A slim DVD-ROM drive should be preinstalled in your server. For servicing the DVD-ROM drive, you will need to remove the top chassis cover. Refer to Chapter 6 if you need to reinstall a DVD-ROM drive to the system.
3. Depending upon your system's configuration, your system may have one or more drives already installed. If you need to install SATA drives, please refer to Chapter 6.

### ***Checking the Airflow***

1. Airflow is provided by four sets of 4-cm fans (each set of fans consists of two fans that are mounted back to back). The system component layout was carefully designed to direct sufficient cooling airflow to the components that generate the most heat.
2. Note that all power and data cables have been routed in such a way that they do not block the airflow generated by the fans.

### ***Providing Power***

1. The last thing you must do is to provide input power to the system. Plug the power cords from the power supply modules into a high-quality power strip that offers protection from electrical noise and power surges.
  2. It is recommended that you use an uninterruptible power supply (UPS).
-

**Notes**

## Chapter 3

### System Interface

#### 3-1 Overview

There are several LEDs on the control panel as well as others on the SATA drive carriers to keep you constantly informed of the overall status of the system as well as the activity and health of specific components. There are also three buttons on the chassis control panel and an on/off switch on the power supply. This chapter explains the meanings of all LED indicators and the appropriate response you may need to take.

Figure 3-1: System Interface

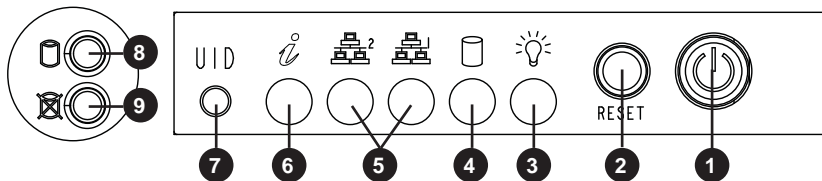

Server Interface Buttons and LEDs	
No.	Description
1	Power Button
2	Reset Button
3	Power LED
4	Device Activity LED
5	LAN1 LED and LAN2 LED
6	Information LED
7	Unit Identifier Button
8	Hard Drive Signal
9	Hard Drive Fail

## 3-2 Control Panel Buttons

There are three push-buttons located on the front of the chassis: a reset button, a UID button and a power on/off button.

### RESET



#### Reset

Use the reset button to reboot the system.



#### Power

This is the main power button, which is used to apply or turn off the main system power. Turning off system power with this button removes the main power but keeps standby power supplied to the system.



#### UID

Depressing the UID (unit identifier) button illuminates an LED on both the front and rear of the chassis for easy system location in large stack configurations. The LED will remain on until the button is pushed a second time. Another UID button on the rear of the chassis serves the same function. See the table in Figure 3-1 for descriptions of UID LED states.

Universal Information LED States	
State	Indication
Fast Blinking Red (1x/sec)	Fan Fail
Solid Red	CPU Overheat
Slow Blinking Red (1x/4 sec)	Power Fail
Solid Blue	Local UID Button Depressed
Blinking Blue	IPMI-Activated UID

**Note:** deactivating the UID LED must be performed in the same way it was activated. (If the UID LED was activated via IPMI, you can only turn the LED off via IPMI and not with the UID button.)

---



### 3-3 Control Panel LEDs

The control panel located on the front of the SC815TQ-R706WB chassis has five LEDs. These LEDs provide you with critical information related to different parts of the system. This section explains what each LED indicates when illuminated and any corrective action you may need to take.



#### Information LED

See the following table for the status shown by this LED.

Information LED	
Status	Description
Continuously on and red	An overheat condition has occurred. (This may be caused by cable congestion.)
Blinking red (1 Hz)	Fan failure: check for an inoperative fan.
Blinking red (0.25 Hz)	Power failure: check for an inoperative power supply.
Solid blue	Local UID has been activated. Use this function to locate the server in a rack environment.
Blinking blue (300 msec)	Remote UID has been activated. Use this function to locate the server from a remote location.



#### NIC2

Indicates network activity on LAN2 when flashing.



#### NIC1

Indicates network activity on LAN1 when flashing.



#### HDD

Indicates IDE channel activity when flashing.



## Power

Indicates power is being supplied to the system's power supply units. This LED should normally be illuminated when the system is operating.

## 3-4 Hard Drive Carrier LEDs

Each hard drive carrier has two LEDs.

- **Green:** When illuminated, the green LED on the front of the drive carrier indicates drive activity. A connection to the drive backplane enables this LED to blink on and off when that particular drive is being accessed.
- **Red:** The red LED indicates two states. When blinking, it indicates the drive is rebuilding. When solid, it indicates a drive failure. If a hard drive fails, you should be notified by your system management software. Please refer to Chapter 6 for instructions on replacing failed hard drives.

## Chapter 4

# Standardized Warning Statements for AC Systems

### 4-1 About Standardized Warning Statements

The following statements are industry standard warnings, provided to warn the user of situations which have the potential for bodily injury. Should you have questions or experience difficulty, contact Supermicro's Technical Support department for assistance. Only certified technicians should attempt to install or configure components.

Read this appendix in its entirety before installing or configuring components in the Supermicro chassis.

These warnings may also be found on our web site at [http://www.supermicro.com/about/policies/safety\\_information.cfm](http://www.supermicro.com/about/policies/safety_information.cfm).

#### Warning Definition



#### Warning!

This warning symbol means danger. You are in a situation that could cause bodily injury. Before you work on any equipment, be aware of the hazards involved with electrical circuitry and be familiar with standard practices for preventing accidents.

#### 警告の定義

この警告サインは危険を意味します。

人身事故につながる可能性がありますので、いずれの機器でも動作させる前に、電気回路に含まれる危険性に注意して、標準的な事故防止策に精通して下さい。

此警告符号代表危險。

您正處於可能受到嚴重傷害的工作環境中。在您使用設備開始工作之前，必須充分意識到觸電的危險，並熟练掌握防止事故發生的標準工作程序。請根據每項警告結尾的聲明號碼找到此設備的安全性警告說明的翻譯文本。

此警告符號代表危險。

您正處於可能身體可能會受損傷的工作環境中。在您使用任何設備之前，請注意觸電的危險，並且要熟悉預防事故發生的標準工作程序。請依照每一注意事項後的號碼找到相關的翻譯說明內容。

## Warnung

### WICHTIGE SICHERHEITSHINWEISE

Dieses Warnsymbol bedeutet Gefahr. Sie befinden sich in einer Situation, die zu Verletzungen führen kann. Machen Sie sich vor der Arbeit mit Geräten mit den Gefahren elektrischer Schaltungen und den üblichen Verfahren zur Vorbeugung vor Unfällen vertraut. Suchen Sie mit der am Ende jeder Warnung angegebenen Anweisungsnummer nach der jeweiligen Übersetzung in den übersetzten Sicherheitshinweisen, die zusammen mit diesem Gerät ausgeliefert wurden.

BEWAHREN SIE DIESE HINWEISE GUT AUF.

### INSTRUCCIONES IMPORTANTES DE SEGURIDAD

Este símbolo de aviso indica peligro. Existe riesgo para su integridad física. Antes de manipular cualquier equipo, considere los riesgos de la corriente eléctrica y familiarícese con los procedimientos estándar de prevención de accidentes. Al final de cada advertencia encontrará el número que le ayudará a encontrar el texto traducido en el apartado de traducciones que acompaña a este dispositivo.

GUARDE ESTAS INSTRUCCIONES.

### IMPORTANTES INFORMATIONS DE SÉCURITÉ

Ce symbole d'avertissement indique un danger. Vous vous trouvez dans une situation pouvant entraîner des blessures ou des dommages corporels. Avant de travailler sur un équipement, soyez conscient des dangers liés aux circuits électriques et familiarisez-vous avec les procédures couramment utilisées pour éviter les accidents. Pour prendre connaissance des traductions des avertissements figurant dans les consignes de sécurité traduites qui accompagnent cet appareil, référez-vous au numéro de l'instruction situé à la fin de chaque avertissement.

CONSERVEZ CES INFORMATIONS.

## תקנון הצהרות אזהרה

הצהרות הבאות הן אזהרות על פי תקני התעשייה, על מנת להזהיר את המשתמש מפני חבלה פיזית אפשרית. במידה ויש שאלות או היתקלות בבעיה כלשהי, יש ליצור קשר עם מחלקת תמיכה טכנית של סופרמיקרו. טכנאים מוסמכים בלבד רשאים להתקין או להגדיר את הרכיבים.

יש לקרוא את הנספח במלואו לפני התקנת או הגדרת הרכיבים במארזי סופרמיקרו.

تحذير! هذا الرمز يعني خطر انك في حالة يمكن أن تتسبب في اصابة جسدية .  
قبل أن تعمل على أي معدات، كن على علم بالمخاطر الناجمة عن الدوائر  
الكهربائية  
وكن على دراية بالممارسات الوقائية لمنع وقوع أي حوادث  
استخدم رقم البيان المنصوص في نهاية كل تحذير للعثور ترجمتها

안전을 위한 주의사항

경고!

이 경고 기호는 위험이 있음을 알려 줍니다. 작업자의 신체에 부상을 야기 할 수 있는 상태에 있게 됩니다. 모든 장비에 대한 작업을 수행하기 전에 전기회로와 관련된 위험요소들을 확인하시고 사전에 사고를 방지할 수 있도록 표준 작업절차를 준수해 주시기 바랍니다.

해당 번역문을 찾기 위해 각 경고의 마지막 부분에 제공된 경고문 번호를 참조하십시오

#### BELANGRIJKE VEILIGHEIDSINSTRUCTIES

Dit waarschuwings symbool betekent gevaar. U verkeert in een situatie die lichamelijk letsel kan veroorzaken. Voordat u aan enige apparatuur gaat werken, dient u zich bewust te zijn van de bij een elektrische installatie betrokken risico's en dient u op de hoogte te zijn van de standaard procedures om ongelukken te voorkomen. Gebruik de nummers aan het eind van elke waarschuwing om deze te herleiden naar de desbetreffende locatie.

#### BEWAAR DEZE INSTRUCTIES

## Installation Instructions



### Warning!

Read the installation instructions before connecting the system to the power source.

設置手順書

システムを電源に接続する前に、設置手順書をお読み下さい。

警告

将此系统连接电源前，请先阅读安装说明。

警告

將系統與電源連接前，請先閱讀安裝說明。

Warnung

Vor dem Anschließen des Systems an die Stromquelle die Installationsanweisungen lesen.

¡Advertencia!

Lea las instrucciones de instalación antes de conectar el sistema a la red de alimentación.

Attention

Avant de brancher le système sur la source d'alimentation, consulter les directives d'installation.

יש לקרוא את הוראות התקנה לפני חיבור המערכת למקור מתח.

اقرأ إرشادات التركيب قبل توصيل النظام إلى مصدر للطاقة

시스템을 전원에 연결하기 전에 설치 안내를 읽어주십시오.

Waarschuwing

Raadpleeg de installatie-instructies voordat u het systeem op de voedingsbron aansluit.

## Circuit Breaker



### Warning!

This product relies on the building's installation for short-circuit (overcurrent) protection. Ensure that the protective device is rated not greater than: 250 V, 20 A.

### サーキット・ブレーカー

この製品は、短絡(過電流)保護装置がある建物での設置を前提としています。  
保護装置の定格が250 V、20 Aを超えないことを確認下さい。

### 警告

此产品的短路(过载电流)保护由建筑物的供电系统提供,确保短路保护设备的额定电流不大于250V,20A。

### 警告

此產品的短路(過載電流)保護由建築物的供電系統提供,確保短路保護設備的額定電流不大於250V,20A。

### Warnung

Dieses Produkt ist darauf angewiesen, dass im Gebäude ein Kurzschluss- bzw. Überstromschutz installiert ist. Stellen Sie sicher, dass der Nennwert der Schutzvorrichtung nicht mehr als: 250 V, 20 A beträgt.

### ¡Advertencia!

Este equipo utiliza el sistema de protección contra cortocircuitos (o sobrecorrientes) del edificio. Asegúrese de que el dispositivo de protección no sea superior a: 250 V, 20 A.

### Attention

Pour ce qui est de la protection contre les courts-circuits (surtension), ce produit dépend de l'installation électrique du local. Vérifiez que le courant nominal du dispositif de protection n'est pas supérieur à :250 V, 20 A.

מוצר זה מסתמך על הגנה המותקנת במבנים למניעת קצר חשמלי. יש לוודא כי  
המכשיר המגן מפני הקצר החשמלי הוא לא יותר מ-250 V, 20 A

هذا المنتج يعتمد على معدات الحماية من الدوائر القصيرة التي تم تثبيتها في المبنى

تأكد من أن تقييم الجهاز الوقائي ليس أكثر من: 20A, 250V

경고!

이 제품은 전원의 단락(과전류)방지에 대해서 전적으로 건물의 관련 설비에 의존합니다. 보호장치의 정격이 반드시 250V(볼트), 20A(암페어)를 초과하지 않도록 해야 합니다.

Waarschuwing

Dit product is afhankelijk van de kortsluitbeveiliging (overspanning) van uw elektrische installatie. Controleer of het beveiligde apparaat niet groter gedimensioneerd is dan 220V, 20A.

### Power Disconnection Warning



#### Warning!

The system must be disconnected from all sources of power and the power cord removed from the power supply module(s) before accessing the chassis interior to install or remove system components.

#### 電源切斷の警告

システムコンポーネントの取り付けまたは取り外しのために、シャーシ内部にアクセスするには、

システムの電源はすべてのソースから切斷され、電源コードは電源モジュールから取り外す必要があります。

警告

在你打开机箱并安装或移除内部器件前,必须将系统完全断电,并移除电源线。

警告

在您打開機殼安裝或移除內部元件前,必須將系統完全斷電,並移除電源線。



Warnung

Das System muss von allen Quellen der Energie und vom Netzanschlusskabel getrennt sein, das von den Spg.Versorgungsteilmodulen entfernt wird, bevor es auf den Chassisinnenraum zurückgreift, um Systemsbestandteile anzubringen oder zu entfernen.

¡Advertencia!

El sistema debe ser disconnected de todas las fuentes de energía y del cable eléctrico quitado de los módulos de fuente de alimentación antes de tener acceso el interior del chasis para instalar o para quitar componentes de sistema.

Attention

Le système doit être débranché de toutes les sources de puissance ainsi que de son cordon d'alimentation secteur avant d'accéder à l'intérieur du chasis pour installer ou enlever des composants de système.

## אזהרה מפני ניתוק חשמלי

### אזהרה!

יש לנתק את המערכת מכל מקורות החשמל ויש להסיר את כבל החשמלי מהספק לפני גישה לחלק הפנימי של המארז לצורך התקנת או הסרת רכיבים.

يجب فصل النظام من جميع مصادر الطاقة وإزالة سلك الكهرباء من وحدة امداد الطاقة قبل الوصول إلى المناطق الداخلية للهيكल لتثبيت أو إزالة مكونات الجهاز

경고!

시스템에 부품들을 장착하거나 제거하기 위해서는 새시 내부에 접근하기 전에 반드시 전원 공급장치로부터 연결되어있는 모든 전원과 전기코드를 분리해주어야 합니다.

Waarschuwing

Voordat u toegang neemt tot het binnenwerk van de behuizing voor het installeren of verwijderen van systeem onderdelen, dient u alle spanningsbronnen en alle stroomkabels aangesloten op de voeding(en) van de behuizing te verwijderen

## Equipment Installation



### Warning!

Only trained and qualified personnel should be allowed to install, replace, or service this equipment.

### 機器の設置

トレーニングを受け認定された人だけがこの装置の設置、交換、またはサービスを許可されています。

### 警告

只有经过培训且具有资格的人员才能进行此设备的安装、更换和维修。

### 警告

只有經過受訓且具資格人員才可安裝、更換與維修此設備。

### Warnung

Das Installieren, Ersetzen oder Bedienen dieser Ausrüstung sollte nur geschultem, qualifiziertem Personal gestattet werden.

### ¡Advertencia!

Solamente el personal calificado debe instalar, reemplazar o utilizar este equipo.

### Attention

Il est vivement recommandé de confier l'installation, le remplacement et la maintenance de ces équipements à des personnels qualifiés et expérimentés.

### אזהרה!

צוות מוסמך בלבד רשאי להתקין, להחליף את הציוד או לתת שירות עבור הציוד.

يجب أن يسمح فقط للموظفين المؤهلين والمدربين لتثبيت واستبدال أو خدمة هذا الجهاز

### 경고!

훈련을 받고 공인된 기술자만이 이 장비의 설치, 교체 또는 서비스를 수행할 수 있습니다.

## Waarschuwing

Deze apparatuur mag alleen worden geïnstalleerd, vervangen of hersteld door geschoold en gekwalificeerd personeel.

## Restricted Area



### Warning!

This unit is intended for installation in restricted access areas. A restricted access area can be accessed only through the use of a special tool, lock and key, or other means of security. (This warning does not apply to workstations).

### アクセス制限区域

このユニットは、アクセス制限区域に設置されることを想定しています。

アクセス制限区域は、特別なツール、鍵と錠前、その他のセキュリティの手段を用いてのみ出入りが可能です。

### 警告

此部件应安装在限制进出的场所，限制进出的场所指只能通过使用特殊工具、锁和钥匙或其它安全手段进出的场所。

### 警告

此裝置僅限安裝於進出管制區域，進出管制區域係指僅能以特殊工具、鎖頭及鑰匙或其他安全方式才能進入的區域。

### Warnung

Diese Einheit ist zur Installation in Bereichen mit beschränktem Zutritt vorgesehen. Der Zutritt zu derartigen Bereichen ist nur mit einem Spezialwerkzeug, Schloss und Schlüssel oder einer sonstigen Sicherheitsvorkehrung möglich.

### ¡Advertencia!

Esta unidad ha sido diseñada para instalación en áreas de acceso restringido. Sólo puede obtenerse acceso a una de estas áreas mediante la utilización de una herramienta especial, cerradura con llave u otro medio de seguridad.

### Attention

Cet appareil doit être installée dans des zones d'accès réservés. L'accès à une zone d'accès réservé n'est possible qu'en utilisant un outil spécial, un mécanisme de verrouillage et une clé, ou tout autre moyen de sécurité.

## אזור עם גישה מוגבלת

### !אזהרה!

יש להתקין את היחידה באזורים שיש בהם הגבלת גישה. הגישה ניתנת בעזרת כלי אבטחה בלבד (מפתח, מנעול וכד').

تم تخصيص هذه الوحدة لتركيبها في مناطق محظورة .  
يمكن الوصول إلى منطقة محظورة فقط من خلال استخدام أداة خاصة،  
قفل ومفتاح أو أي وسيلة أخرى للأمان

경고!

이 장치는 접근이 제한된 구역에 설치하도록 되어있습니다. 특수도구, 잠금 장치 및 키, 또는 기타 보안 수단을 통해서만 접근 제한 구역에 들어갈 수 있습니다.

### Waarschuwing

Dit apparaat is bedoeld voor installatie in gebieden met een beperkte toegang. Toegang tot dergelijke gebieden kunnen alleen verkregen worden door gebruik te maken van speciaal gereedschap, slot en sleutel of andere veiligheidsmaatregelen.

## Battery Handling



### Warning!

There is the danger of explosion if the battery is replaced incorrectly. Replace the battery only with the same or equivalent type recommended by the manufacturer. Dispose of used batteries according to the manufacturer's instructions

### 電池の取り扱い

電池交換が正しく行われなかった場合、破裂の危険性があります。交換する電池はメーカーが推奨する型、または同等のものを使用下さい。使用済電池は製造元の指示に従って処分して下さい。

### 警告

电池更换不当会有爆炸危险。请只使用同类电池或制造商推荐的功能相当的电池更换原有电池。请按制造商的说明处理废旧电池。

### 警告

電池更換不當會有爆炸危險。請使用製造商建議之相同或功能相當的電池更換原有電池。請按照製造商的說明指示處理廢棄舊電池。

Warnung

Bei Einsetzen einer falschen Batterie besteht Explosionsgefahr. Ersetzen Sie die Batterie nur durch den gleichen oder vom Hersteller empfohlenen Batterietyp. Entsorgen Sie die benutzten Batterien nach den Anweisungen des Herstellers.

Attention

Danger d'explosion si la pile n'est pas remplacée correctement. Ne la remplacer que par une pile de type semblable ou équivalent, recommandée par le fabricant. Jeter les piles usagées conformément aux instructions du fabricant.

¡Advertencia!

Existe peligro de explosión si la batería se reemplaza de manera incorrecta. Reemplazar la batería exclusivamente con el mismo tipo o el equivalente recomendado por el fabricante. Desechar las baterías gastadas según las instrucciones del fabricante.

**אזהרה!**

קיימת סכנת פיצוץ של הסוללה במידה והוחלפה בדרך לא תקינה. יש להחליף את הסוללה בסוג התואם מחברת יצרן מומלצת.

סילוק הסוללות המשומשות יש לבצע לפי הוראות היצרן.

هناك خطر من انفجار في حالة استبدال البطارية بطريقة غير صحيحة فعليك استبدال البطارية فقط بنفس النوع أو ما يعادلها كما أوصت به الشركة المصنعة تخلص من البطاريات المستعملة وفقا لتعليمات الشركة الصانعة

경고!

배터리가 올바르게 교체되지 않으면 폭발의 위험이 있습니다. 기존 배터리와 동일하거나 제조사에서 권장하는 동등한 종류의 배터리로만 교체해야 합니다. 제조사의 안내에 따라 사용된 배터리를 처리하여 주십시오.

Waarschuwing

Er is ontploffingsgevaar indien de batterij verkeerd vervangen wordt. Vervang de batterij slechts met hetzelfde of een equivalent type die door de fabrikant aanbevolen wordt. Gebruikte batterijen dienen overeenkomstig fabrieksvoorschriften afgevoerd te worden.

## Redundant Power Supplies



### Warning!

This unit might have more than one power supply connection. All connections must be removed to de-energize the unit.

#### 冗長電源装置

このユニットは複数の電源装置が接続されている場合があります。  
ユニットの電源を切るためには、すべての接続を取り外さなければなりません。

#### 警告

此部件连接的电源可能不止一个，必须将所有电源断开才能停止给该部件供电。

#### 警告

此装置连接的电源可能不只一个，必须切断所有电源才能停止对该装置的供电。

#### Warnung

Dieses Gerät kann mehr als eine Stromzufuhr haben. Um sicherzustellen, dass der Einheit kein Strom zugeführt wird, müssen alle Verbindungen entfernt werden.

#### ¡Advertencia!

Puede que esta unidad tenga más de una conexión para fuentes de alimentación. Para cortar por completo el suministro de energía, deben desconectarse todas las conexiones.

#### Attention

Cette unité peut avoir plus d'une connexion d'alimentation. Pour supprimer toute tension et tout courant électrique de l'unité, toutes les connexions d'alimentation doivent être débranchées.

**אם קיים יותר מספק אחד**

**אזהרה!**

ליחידה יש יותר מחיבור אחד של ספק. יש להסיר את כל החיבורים על מנת לרוקן את היחידה.

قد يكون لهذا الجهاز عدة اتصالات بوحدات امداد الطاقة.  
يجب إزالة كافة الاتصالات لعزل الوحدة عن الكهرباء

경고!

이 장치에는 한 개 이상의 전원 공급 단자가 연결되어 있을 수 있습니다. 이 장치에 전원을 차단하기 위해서는 모든 연결 단자를 제거해야만 합니다.

Waarschuwing

Deze eenheid kan meer dan één stroomtoevoeraansluiting bevatten. Alle aansluitingen dienen verwijderd te worden om het apparaat stroomloos te maken.

### Backplane Voltage



**Warning!**

Hazardous voltage or energy is present on the backplane when the system is operating. Use caution when servicing.

バックプレーンの電圧

システムの稼働中は危険な電圧または電力が、バックプレーン上にかかっています。  
修理するには注意ください。

警告

当系统正在进行时，背板上有很危险的电压或能量，进行维修时务必小心。

警告

當系統正在進行時，背板上有很危險的電壓或能量，進行維修時務必小心。

Warnung

Wenn das System in Betrieb ist, treten auf der Rückwandplatine gefährliche Spannungen oder Energien auf. Vorsicht bei der Wartung.

¡Advertencia!

Cuando el sistema está en funcionamiento, el voltaje del plano trasero es peligroso. Tenga cuidado cuando lo revise.

Attention

Lorsque le système est en fonctionnement, des tensions électriques circulent sur le fond de panier. Prendre des précautions lors de la maintenance.

מתח בפנל האחורי

אזהרה!  
קיימת סכנת מתח בפנל האחורי בזמן תפעול המערכת. יש להיזהר במהלך העבודה.

هناك خطر من التيار الكهربائي أو الطاقة الموجودة على اللوحة عندما يكون النظام يعمل كن حذرا عند خدمة هذا الجهاز

경고!

시스템이 동작 중일 때 후면판 (Backplane)에는 위험한 전압이나 에너지가 발생합니다. 서비스 작업 시 주의하십시오.

Waarschuwing

Een gevaarlijke spanning of energie is aanwezig op de backplane wanneer het systeem in gebruik is. Voorzichtigheid is geboden tijdens het onderhoud.

**Comply with Local and National Electrical Codes**



**Warning!**

Installation of the equipment must comply with local and national electrical codes.

地方および国の電気規格に準拠

機器の取り付けはその地方および国の電気規格に準拠する必要があります。

警告

设备安装必须符合本地与本国电气法规。

警告

設備安裝必須符合本地與本國電氣法規。

Warnung

Die Installation der Geräte muss den Sicherheitsstandards entsprechen.



¡Advertencia!

La instalacion del equipo debe cumplir con las normas de electricidad locales y nacionales. Attention

L'équipement doit être installé conformément aux normes électriques nationales et locales.

## תיאום חוקי החשמל הארצי

אזהרה!

התקנת הציוד חייבת להיות תואמת לחוקי החשמל המקומיים והארציים.

تركيب المعدات الكهربائية يجب أن يمتثل للقوانين المحلية والوطنية المتعلقة بالكهرباء

경고!

현 지역 및 국가의 전기 규정에 따라 장비를 설치해야 합니다.

Waarschuwing

Bij installatie van de apparatuur moet worden voldaan aan de lokale en nationale elektriciteitsvoorschriften.

## Product Disposal



**Warning!**

Ultimate disposal of this product should be handled according to all national laws and regulations.

製品の廃棄

この製品を廃棄処分する場合、国の関係する全ての法律・条例に従い処理する必要があります。

警告

本产品的废弃处理应根据所有国家的法律和规章进行。

警告

本產品的廢棄處理應根據所有國家的法律和規章進行。

### Warnung

Die Entsorgung dieses Produkts sollte gemäß allen Bestimmungen und Gesetzen des Landes erfolgen.

### ¡Advertencia!

Al deshacerse por completo de este producto debe seguir todas las leyes y reglamentos nacionales.

### Attention

La mise au rebut ou le recyclage de ce produit sont généralement soumis à des lois et/ou directives de respect de l'environnement. Renseignez-vous auprès de l'organisme compétent.

### סילוק המוצר

אזהרה!

סילוק סופי של מוצר זה חייב להיות בהתאם להנחיות וחוקי המדינה.

عند التخلص النهائي من هذا المنتج ينبغي التعامل معه وفقا لجميع القوانين واللوائح الوطنية

경고!

이 제품은 해당 국가의 관련 법규 및 규정에 따라 폐기되어야 합니다.

### Waarschuwing

De uiteindelijke verwijdering van dit product dient te geschieden in overeenstemming met alle nationale wetten en reglementen.

## Easy Swap Fan Warning



### Warning!

The fans might still be turning when you remove the fan assembly from the chassis. Keep fingers, screwdrivers, and other objects away from the openings in the fan assembly's housing.

### ファン・ホットスワップの警告

シャーシから冷却ファン装置を取り外した際、ファンがまだ回転している可能性があります。ファンの開口部に、指、ドライバー、およびその他のものを近づけないで下さい。

警告

当您从机架移除风扇装置，风扇可能仍在转动。小心不要将手指、螺丝起子和其他物品太靠近风扇

警告

當您從機架移除風扇裝置，風扇可能仍在轉動。小心不要將手指、螺絲起子和其他物品太靠近風扇。

Warnung

Die Lüfter drehen sich u. U. noch, wenn die Lüfterbaugruppe aus dem Chassis genommen wird. Halten Sie Finger, Schraubendreher und andere Gegenstände von den Öffnungen des Lüftergehäuses entfernt.

¡Advertencia!

Los ventiladores podran dar vuelta cuando usted quite el montaje del ventilador del chasis. Mantenga los dedos, los destornilladores y todos los objetos lejos de las aberturas del ventilador

Attention

Il est possible que les ventilateurs soient toujours en rotation lorsque vous retirerez le bloc ventilateur du châssis. Prenez garde à ce que doigts, tournevis et autres objets soient éloignés du logement du bloc ventilateur.

אזהרה!

כאשר מסירים את חלקי המאוורר מהמארז, יתכן והמאווררים עדיין עובדים. יש להרחיק למרחק בטוח את האצבעות וכלי עבודה שונים מהפתחים בתוך המאוורר

من الممكن أن المراوح لا تزال تدور عند إزالة كتلة المروحة من الهيكل يجب إبقاء الأصابع ومفكات البراغي وغيرها من الأشياء بعيدا عن الفتحات في كتلة المروحة.

경고!

새시로부터 팬 조립품을 제거할 때 팬은 여전히 회전하고 있을 수 있습니다. 팬 조립품 외관의 열려있는 부분들로부터 손가락 및 스크류드라이버, 다른 물체들이 가까이 하지 않도록 배치해 주십시오.

## Waarschuwing

Het is mogelijk dat de ventilator nog draait tijdens het verwijderen van het ventilatorsamenstel uit het chassis. Houd uw vingers, schroevendraaiers en eventuele andere voorwerpen uit de buurt van de openingen in de ventilatorbehuizing.

## Power Cable and AC Adapter



### Warning!

When installing the product, use the provided or designated connection cables, power cables and AC adaptors. Using any other cables and adaptors could cause a malfunction or a fire. Electrical Appliance and Material Safety Law prohibits the use of UL or CSA -certified cables (that have UL/CSA shown on the code) for any other electrical devices than products designated by Supermicro only.

### 電源コードとACアダプター

製品を設置する場合、提供または指定された接続ケーブル、電源コードとACアダプターを使用下さい。他のケーブルやアダプタを使用すると故障や火災の原因になることがあります。電気用品安全法は、ULまたはCSA認定のケーブル(UL/CSEマークがコードに表記)を Supermicroが指定する製品以外に使用することを禁止しています。

### 警告

安裝此產品時，請使用本身提供的或指定的連接線，電源線和電源適配器。使用其它線材或適配器可能會引起故障或火災。除了 Supermicro 所指定的產品，電氣用品和材料安全法律規定禁止使用未經 UL 或 CSA 認證的線材。（線材上會顯示 UL/CSA 符號）。

### 警告

安裝此產品時，請使用本身提供的或指定的連接線，電源線和電源適配器。使用其它線材或適配器可能會引起故障或火災。除了 Supermicro 所指定的產品，電氣用品和材料安全法律規定禁止使用未經 UL 或 CSA 認證的線材。（線材上會顯示 UL/CSA 符號）。

### Warnung

Bei der Installation des Produkts, die zur Verfügung gestellten oder benannt Anschlusskabel, Stromkabel und Netzteile. Verwendung anderer Kabel und Adapter kann zu einer Fehlfunktion oder ein Brand entstehen. Elektrische Geräte und Material Safety Law verbietet die Verwendung von UL-oder CSA-zertifizierte Kabel, UL oder CSA auf der Code für alle anderen elektrischen Geräte als Produkte von Supermicro nur bezeichnet gezeigt haben.

## ¡Advertencia!

Al instalar el producto, utilice los cables de conexión previstos o designados, los cables y adaptadores de CA. La utilización de otros cables y adaptadores podría ocasionar un mal funcionamiento o un incendio. Aparatos Eléctricos y la Ley de Seguridad del Material prohíbe el uso de UL o CSA cables certificados que tienen UL o CSA se muestra en el código de otros dispositivos eléctricos que los productos designados por Supermicro solamente.

## Attention

Lors de l'installation du produit, utilisez les bables de connection fournis ou désigné. L'utilisation d'autres cables et adaptateurs peut provoquer un dysfonctionnement ou un incendie. Appareils électroménagers et de loi sur la sécurité Matériel interdit l'utilisation de UL ou CSA câbles certifiés qui ont UL ou CSA indiqué sur le code pour tous les autres appareils électriques que les produits désignés par Supermicro seulement.

## AC שמשליים ומתאמי

## אזהרה!

כאשר מתקינים את המוצר, יש להשתמש בכבלים, ספקים ומתאמים AC אשר נועדו וסופקו לשם כך. שימוש בכל כבל או מתאם אחר יכול לגרום לתקלה או קצר חשמלי. על פי חוקי שימוש במכשירי חשמל וחוקי בטיחות, קיים איסור להשתמש בכבלים המוסמכים ב- UL או ב- CSA (כשאר מופיע עליהם קוד של UL/CSA) עבור כל מוצר חשמלי אחר שלא צויין על ידי סופרמיקרו בלבד.

عند تركيب الجهاز يجب استخدام كابلات التوصيل، والكابلات الكهربائية  
ومحولات التيار المتردد

التي . أن استخدام أي كابلات ومحولات أخرى يتسبب في حدوث عطل أو حريق.  
تم توفيرها لك مع المنتج

الأجهزة الكهربائية ومواد قانون السلامة يحظر استخدام الكابلات CSA أو UL  
معتمدة من قبل

لأي أجهزة كهربائية أخرى غير المنتجات المعينة من قبل Supermicro  
(التي تحمل علامة UL/CSA)

## 경고!

제품을 설치할 때에는 제공되거나 지정된 연결케이블과 전원케이블, AC 어댑터를 사용해야 합니다. 그 밖의 다른 케이블들이나 어댑터들은 고장 또는 화재의 원인이 될 수 있습니다. 전기용품안전법 (Electrical Appliance and Material Safety Law)은 슈퍼마이크로에서 지정한 제품들 외에는 그 밖의 다른 전기 장치들을 위한 UL 또는 CSA에서 인증한 케이블(전선 위에 UL/CSA가 표시)들의 사용을 금지합니다.

### Waarschuwing

Bij het installeren van het product, gebruik de meegeleverde of aangewezen kabels, stroomkabels en adapters. Het gebruik van andere kabels en adapters kan leiden tot een storing of een brand. Elektrisch apparaat en veiligheidsinformatiebladen wet verbiedt het gebruik van UL of CSA gecertificeerde kabels die UL of CSA die op de code voor andere elektrische apparaten dan de producten die door Supermicro alleen.

## Chapter 5

### Advanced Serverboard Setup

This chapter covers the steps required to connect the data and power cables and install add-on cards. All serverboard jumpers and connections are also described. A layout and quick reference chart are included in this chapter for your reference. Remember to completely close the chassis when you have finished working with the serverboard to better cool and protect the system.

#### 5-1 Handling the Serverboard

Electrostatic Discharge (ESD) can damage electronic components. To prevent damage to any printed circuit boards (PCBs), it is important to handle them very carefully (see previous chapter). To prevent the serverboard from bending, keep one hand under the center of the board to support it when handling. The following measures are generally sufficient to protect your equipment from electric static discharge.

##### Precautions

- Use a grounded wrist strap designed to prevent ESD.
- Touch a grounded metal object before removing boards from antistatic bags.
- Handle a board by its edges only; do not touch its components, peripheral chips, memory modules or gold contacts.
- When handling chips or modules, avoid touching their pins.
- Put the serverboard, add-on cards and peripherals back into their antistatic bags when not in use.
- For grounding purposes, make sure your computer chassis provides excellent conductivity between the power supply, the case, the mounting fasteners and the serverboard.

##### Unpacking

The serverboard is shipped in antistatic packaging to avoid electrical static discharge. When unpacking the board, make sure the person handling it is static protected.

## 5-2 Connecting Cables

Now that the serverboard is installed, the next step is to connect the cables to the board. These include the data cables for the peripherals and control panel and the power cables.

### Connecting Data Cables

The cables used to transfer data from the peripheral devices have been carefully routed to prevent them from blocking the flow of cooling air that moves through the system from front to back. If you need to disconnect any of these cables, you should take care to keep them routed as they were originally after reconnecting them (make sure the red wires connect to the pin 1 locations). The following data cables (with their locations noted) should be connected. (See the layout on page 5-10 for connector locations.)

- One 77-cm 10-pin to 10-pin 26-AWG two-channel USB cable (CBL-0263L)
- Two 29-cm 30-AWG SATA cables (CBL-0483L)
- One 27-cm 8-pin to 8-pin round SGPIO cable (CBL-CDAT-0660)
- One 40-cm 8-pin to 8-pin round SGPIO cable (CBL-CDAT-0661)
- One 61.5-cm 28-AWG SGPIO cable (CBL-CDAT-0662)
- Two 31-cm 30-AWG SATA cables (CBL-SAST-0639)
- Two 38-cm 30-AWG SATA cables (CBL-SAST-0640)
- Two 45-cm 30-AWG SATA cables (CBL-SAST-0641)
- Two 55-cm 30-AWG SATA cables (CBL-0488L)

**Important!** Make sure the cables do not come into contact with the fans.

### Connecting Power Cables

The X10DRW-i(T) has a 24-pin primary power supply connector (JPW1) for connection to the ATX power supply. In addition, there are two 8-pin 12V processor power connectors (JPW2 and JPW3) that must be connected to your power supply. See Section 5-9 for power connector pin definitions.



## Connecting the Control Panel

JF1 contains header pins for various front control panel connectors. See Figure 5-1 for the pin locations of the various front control panel buttons and LED indicators.

All JF1 wires have been bundled into a single cable to simplify this connection. Make sure the red wire plugs into pin 1 as marked on the board. The other end connects to the Control Panel PCB board, located just behind the system status LEDs on the chassis. Use the 70-cm 20-pin to 20-pin 20-AWG front control cable (CBL-0335L) to connect to the control panel connections.

**Figure 5-1. Control Panel Header Pins**

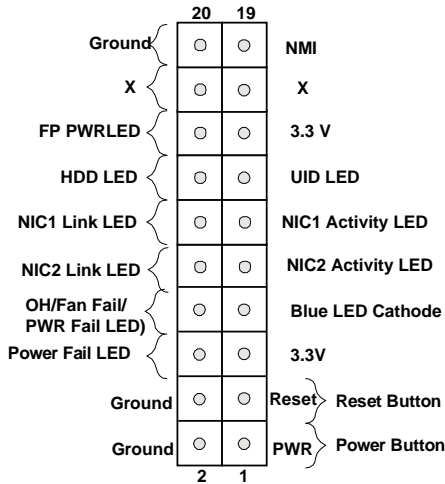

### 5-3 Rear I/O Ports

The I/O ports are in conformance with the PC 99 specification. See Figure 5-2 below for the locations of the various I/O ports.

Figure 5-2. Rear I/O Ports

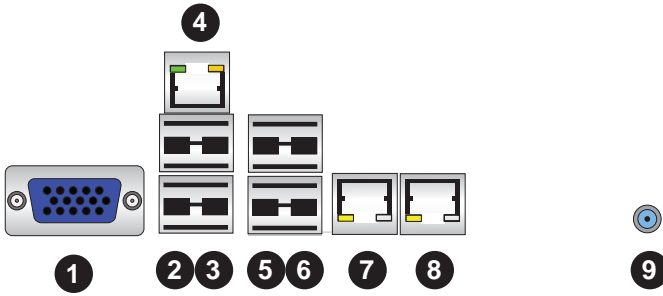

Rear I/O Ports	
1	VGA Port
2	USB 3.0 Port 0
3	USB 3.0 Port 1
4	IPMI Dedicated LAN Port
5	USB 3.0 Port 2
6	USB 3.0 Port 3
7	Gigabit LAN1 (X10DRW-i) or 10-Gigabit LAN1 (X10DRW-iT)
8	Gigabit LAN2 (X10DRW-i) or 10-Gigabit LAN2 (X10DRW-iT)
9	UID Switch/UID LED (LED1)

## 5-4 Installing the Processor and Heatsink

**Caution:** When handling the processor package, avoid placing direct pressure on the label area of the fan.

**Notes:**

- Always connect the power cord last and always remove it before adding, removing or changing any hardware components. Make sure that you install the processor into the CPU socket before you install the CPU heatsink.
- If you buy a CPU separately, make sure that you use an Intel-certified multi-directional heatsink only.
- Make sure to install the serverboard into the chassis before you install the CPU heatsinks.
- When receiving a serverboard without a processor pre-installed, make sure that the plastic CPU socket cap is in place and none of the socket pins are bent; otherwise, contact your retailer immediately.
- Refer to the [Supermicro](#) web site for updates on CPU support.

### Installing an LGA 2011 Processor

1. There are two levers on the LGA2011 socket. First press and release the load lever labeled 'Open 1st'.
2. Press the second load lever labeled 'Close 1st' to release the load plate from its locked position.

Press down on the lever labeled

'Close 1st'

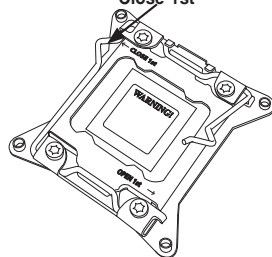

Pull lever away  
from the socket

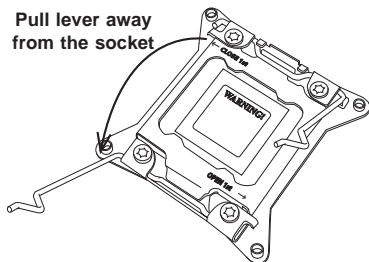

3. With the lever labeled 'Close 1st' fully retracted, gently push down on the 'Open 1st' lever to open the load plate. Lift the load plate to open it completely.

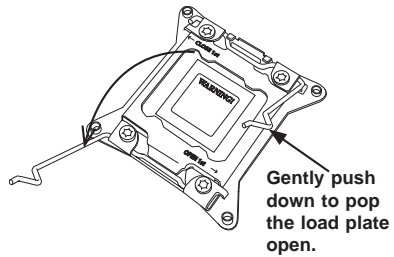

4. Using your thumb and the index finger, remove the 'WARNING' plastic cap from the socket.

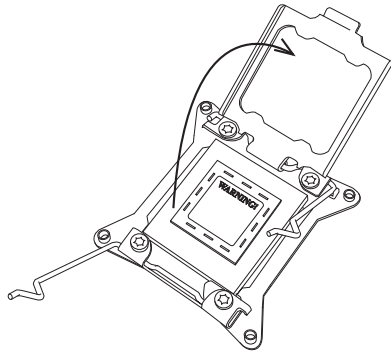

5. Use your thumb and index finger to hold the CPU by its edges. Align the CPU keys, which are semi-circle cutouts, against the socket keys.
6. Once they are aligned, carefully lower the CPU straight down into the socket. (Do not drop the CPU on the socket. Do not move the CPU horizontally or vertically and do not rub the CPU against any pins of the socket, which may damage the CPU or the socket.)

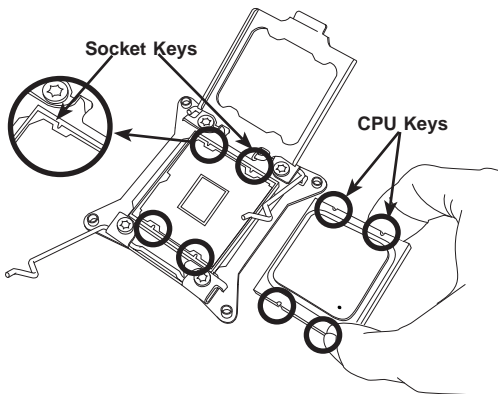

**Caution:** You can only install the CPU to the socket in one direction. Make sure that the CPU is properly inserted into the socket before closing the load plate. If it doesn't close properly, do not force it as it may damage your CPU. Instead, open the load plate again and double-check that the CPU is aligned properly.

7. With the CPU in the socket, inspect the four corners of the CPU to make sure that they are flush with the socket.
8. Close the load plate. Lock the lever labeled 'Close 1st', then lock the lever labeled 'Open 1st'. Use your thumb to gently push the load levers down until the lever locks.

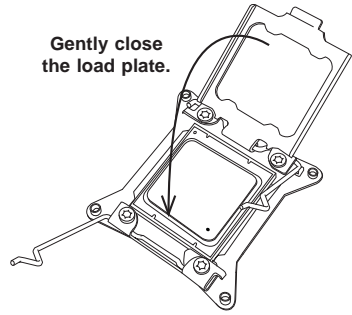

**Push down and lock the level labeled 'Close 1st'.**

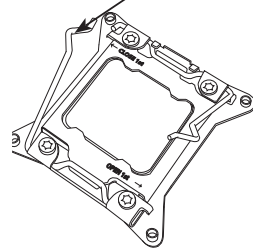

9. Repeat steps to install to the remaining CPU socket.

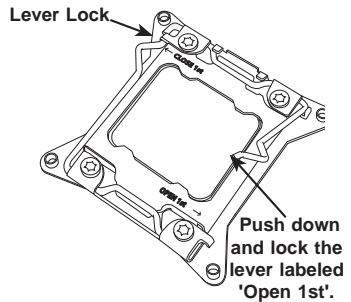

## Installing and Removing a Passive CPU Heatsink

1. Install the 1U passive CPU heatsink part number SNK-P0047PSC or SNK-P0057PSC in the CPU1 location with the air tunnel facing to the right (looking from the front).
2. Install the 1U passive CPU heatsink part number SNK-P0057PS in the CPU2 location.
3. Do not apply any thermal grease to the heatsink or the CPU die; the required amount has already been applied.
4. Place the heatsink on top of the CPU so that the four mounting holes are aligned with those on the serverboard and the heatsink bracket underneath.
5. Screw in two diagonal screws (i.e., the #1 and the #2 screws) until just snug (to avoid possible damage to the CPU, do not over-tighten the screws.)
6. Add the two remaining screws then fully tighten all four screws.

### Removing the Heatsink

**Caution:** Removing the CPU or the heatsink is not recommended. However, if necessary, please follow the instructions below.

1. Unscrew the heatsink screws from the serverboard in the sequence shown.
2. Gently wriggle the heatsink to loosen it from the CPU (do not use excessive force). Once the CPU is loose, remove it from the CPU socket.
3. Clean the surface of the CPU and the heatsink to remove the used thermal grease. Reapply the proper amount of thermal grease then re-install the CPU and the heatsink.

Figure 5-3. Installing the Heatsink

Loosen screws  
in sequence as  
shown.

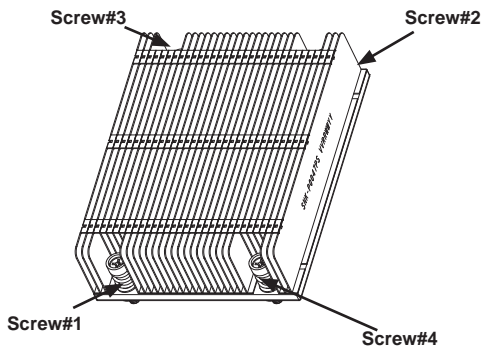

## 5-5 Installing Memory

**Caution!** Exercise extreme care when installing or removing DIMM modules to prevent any possible damage.

### Memory Support

The X10DRW-i(T) supports up to 1024 GB of ECC registered (RDIMM) or ECC Load Reduced (LRDIMM) DDR4 2133/1866/1600/1333 MHz speed, 1 GB, 2 GB, 4 GB, 8 GB, 16 GB, 32 GB and 64 GB size @ 1.2V voltage SDRAM in sixteen (16) DIMM sockets. All channels will run at the fastest common frequency.

### DIMM Installation

#### *Installing Memory Modules*

1. Insert the desired number of DIMMs into the memory slots starting with P1-DIMMA1. See the Memory Installation Tables below.
2. Insert each DIMM module vertically into its slot. Pay attention to the notch along the bottom of the module to avoid installing incorrectly (see Figure 5-3).
3. Use your thumbs to gently press down on both ends of the DIMM module until it snaps into place in the slot. Repeat for all modules.
4. Press the release tabs to the locked positions to secure the DIMM module into the slot.

**Figure 5-4. DIMM Installation**

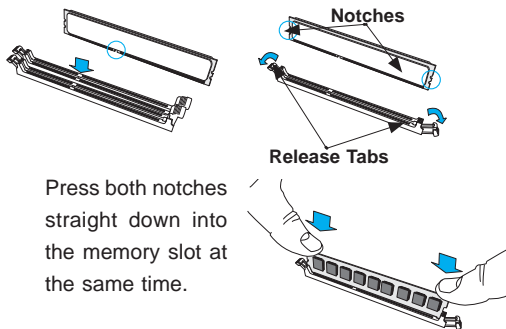

**DIMM Module Population Table**

Follow the tables below when installing memory.

<b>Processors and their Corresponding Memory Modules</b>								
<b>CPU#</b>	<b>Corresponding DIMM Modules</b>							
<b>CPU 1</b>	P1-DIMMA1	P1-DIMMB1	P1-DIMMC1	P1-DIMMD1	P1-DIMMA2	P1-DIMMB2	P1-DIMMC2	P1-DIMMD2
<b>CPU2</b>	P2-DIMME1	P2-DIMMF1	P2-DIMMG1	P2-DIMMH1	P2-DIMME2	P2-DIMM F2	P2-DIMMG2	P2-DIMMH2

<b>Processor and Memory Module Population for Optimal Performance</b>	
<b>Number of CPUs+DIMMs</b>	<b>CPU and Memory Population Configuration Table (For memory to work properly, please follow the instructions below.)</b>
<b>1 CPU &amp; 2 DIMMs</b>	CPU1 P1-DIMMA1/P1-DIMMB1
<b>1 CPU &amp; 4 DIMMs</b>	CPU1 P1-DIMMA1/P1-DIMMB1, P1-DIMMC1/P1-DIMMD1
<b>1 CPU &amp; 5-8 DIMMs</b>	CPU1 P1-DIMMA1/P1-DIMMB1, P1-DIMMC1/P1-DIMMD1 + Any memory pairs in P1-DIMMA2/P1-DIMMB2/P1-DIMMC2/P1-DIMMD2 slots
<b>2 CPUs &amp; 4 DIMMs</b>	CPU1 + CPU2 P1-DIMMA1/P1-DIMMB1, P2-DIMME1/P2-DIMMF1
<b>2 CPUs &amp; 6 DIMMs</b>	CPU1 + CPU2 P1-DIMMA1/P1-DIMMB1/P1-DIMMC1/P1-DIMMD1, P2-DIMME1/P2-DIMMF1
<b>2 CPUs &amp; 8 DIMMs</b>	CPU1 + CPU2 P1-DIMMA1/P1-DIMMB1/P1-DIMMC1/P1-DIMMD1, P2-DIMME1/P2-DIMMF1/P2-DIMMG1/P2-DIMMH1
<b>2 CPUs &amp; 9-16 DIMMs</b>	CPU1/CPU2 P1-DIMMA1/P1-DIMMB1/P1-DIMMC1/P1-DIMMD1, P2-DIMME1/P2-DIMMF1/P2-DIMMG1/P2-DIMMH1 + Any memory pairs in P1, P2 DIMM slots
<b>2 CPUs &amp; 16 DIMMs</b>	CPU1/CPU2 P1-DIMMA1/P1-DIMMB1/P1-DIMMC1/P1-DIMMD1, P2-DIMME1/P2-DIMMF1/P2-DIMMG1/P2-DIMMH1, P1-DIMMA2/P1-DIMMB2/P1-DIMMC2/P1-DIMMD2, P2-DIMME2/P2-DIMMF2/P2-DIMMG2/P2-DIMMH2



### Populating RDIMM/LRDIMM Memory Modules

Intel E5-2600v3 Series Processor Memory Support						
Type	Ranks Per DIMM & Data Width	DIMM Capacity (GB)		Speed (MT/s), Voltage (V), Slot per Channel (SPC) and DIMM Per Channel (DPC)		
				1 Slot Per Channel	2 Slots Per Channel	
				1DPC	1DPC	2DPC
		4Gb	8Gb	1.2V	1.2V	1.2V
RDIMM	SRx4	8GB	16GB	2133 MHz	2133 MHz	1866 MHz
RDIMM	SRx8	4GB	8GB	2133 MHz	2133 MHz	1866 MHz
RDIMM	DRx8	8GB	16GB	2133 MHz	2133 MHz	1866 MHz
RDIMM	DRx4	16GB	32GB	2133 MHz	2133 MHz	1866 MHz
LRDIMM	QRx4	32GB	64GB	2133 MHz	2133 MHz	2133 MHz

**Note:** Please refer to our website @ <http://www.supernmicro.com/products/serverboard> for the latest memory support updates.

#### Other Important Notes and Restrictions

- For the memory modules to work properly, please install DIMM modules of the same type, same speed and same operating frequency. Mixing of RDIMMs, UDIMMs or LRDIMMs is not allowed. Do not install both ECC and non-ECC memory modules on the same serverboard.
- Using DDR4 DIMMs with different operating frequencies is not allowed. All channels in a system will run at the lowest common frequency.

## 5-4 Serverboard Details

Figure 5-5. X10DRW-i(T) Layout

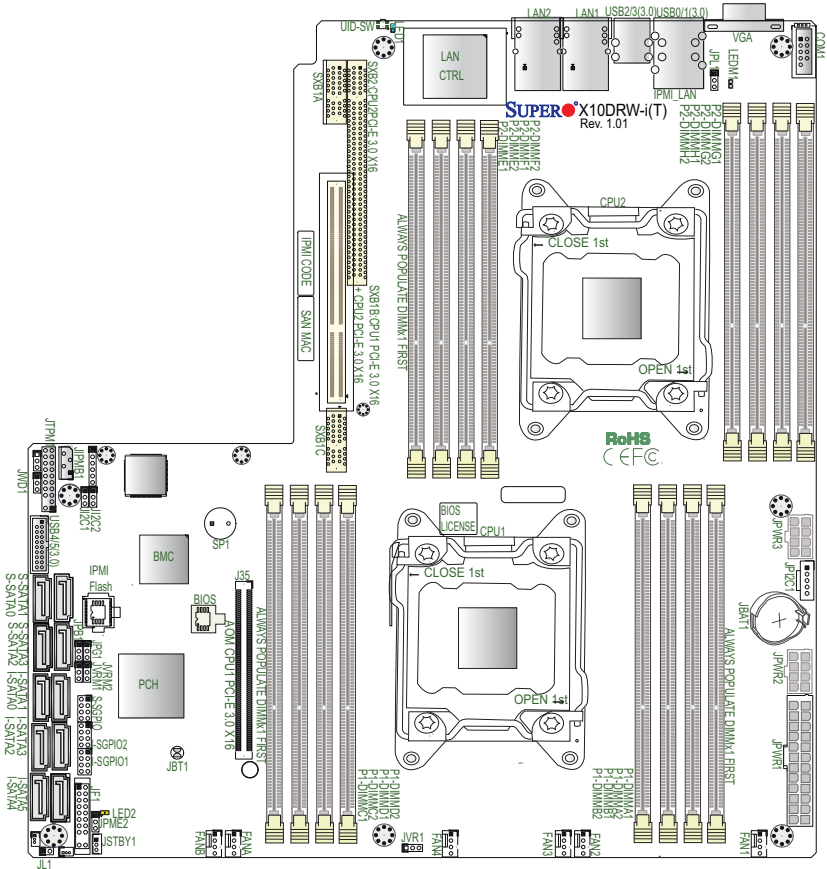

**Caution:** 1) To avoid damaging the motherboard and its components, please do not use a force greater than 8 lb/inch on each mounting screw during motherboard installation. 2) Some components are very close to the mounting holes. Please take precautionary measures to prevent damage to these components when installing the motherboard to the chassis.

<b>X10DRW-i(T) Connectors</b>	
<b>Connectors</b>	<b>Description</b>
AOM Slot (J35)	PCI-E 3.0 x16 Add-On-Module (AOM) slot for the mezzanine HBA card
Battery (JBAT1)	Onboard CMOS Battery (See Chpt. 3 for used battery disposal)
COM1	Backplane COM port
Fan1-4, FanA/B	CPU/System fan headers (Fan1-Fan4), PCH/Peripheral fan headers (FanA-FanB)
JF1	Front_Panel_Control header
JIPMB1	4-pin external BMC I <sup>2</sup> C header (for IPMI-card support)
JL1	Chassis Intrusion
JPI <sup>2</sup> C1	Power supply SMBbus I <sup>2</sup> C header
JPWR1	24-pin ATX main power connector
JPWR2/3	12V 8-Pin power connectors
JSTBY1	Standby power connector
JTPM1	TPM (Trusted Platform Module)/Port 80 header
LAN1/LAN2	G-bit Ethernet (GLAN) ports 1/2 (for X10DRW-i) 10G-bit Ethernet (GLAN) ports 1/2 (for X10DRW-iT)
(IPMI)_LAN	IPMI_Dedicated LAN support by the Aspeed controller
(I-)SATA 0-5	Intel SATA 3.0 connectors (0-5) from Intel PCH
(S)-SATA0-3	SATA 3.0 connectors (0-3) from Intel SCU
I-SGPIO1/2	Serial_Link General-Purpose I/O (SGPIO) headers for I-SATA connections (I-SGPIO1 for I-SATA0-3, I-SGPIO2 for I-SATA4/5)
<b>Connectors</b>	<b>Description</b>
S-SGPIO	Serial_Link General-Purpose (SGPIO) I/O header for S-SATA connections 0-3
SP1	Internal speaker/buzzer
SXB1A	SMC-proprietary SPEC slot (Left) (See Note 2 below.)
SXB1B	(CPU1/CPU2) PCI-E 3.0x16 + x16 add-on card slot (Left) (Note 2 below.)
SXB1C	SMC-proprietary SPEC slot (Left) (See Note 2 below.)
SXB2	SMC-proprietary PCI-E 3.0x16 add-on card slot (Right) (See Note 3 below.)
UID-SW	UID Switch
(BP) USB 0/1 (3.0)	Backpanel USB 3.0 Port 0/ Port 1
(BP) USB 2/3 (3.0)	Backpanel USB 3.0 connections 2/3
(FP) USB 4/5 (3.0)	Front Accessible USB 3.0 connections header 4/5
VGA	Backpanel VGA port

**X10DRW-i(T) Jumpers**

Jumper	Description	Default Setting
JBT1	Clear CMOS	See Chapter 3
JIP1/JIP2	SMB to PCI-E slots	Pins 2-3 (Disabled)
JPB1	BMC Enable	Pins 1-2 (Enabled)
JPG1	VGA Enable	Pins 1-2 (Enabled)
JPL1	GLAN1/GLAN2 Enable (X10DRW-i) 10G_LAN1/10G_LAN2 Enable (X10DRW-iT)	Pins 1-2 (Enabled)
JPME2	Manufacture (ME) Mode Select	Pins 1-2 (Normal)
JWD1	Watch-Dog Timer Enable	Pins 1-2 (Reset)

**X10DRW-i(T) LED Indicators**

LED	Description	State	Status
LED1	Rear UID LED	Blue: On	Unit Identified
LED2	Onboard PWR LED	On	System Power On
LEDM1	BMC Heartbeat LED	Green: Blinking	BMC Normal

**Note 1:** For SXB1A/SXB1B/SXB1C PCI-E slot to work properly, please use an SMC-proprietary riser card (eg. RSC-R1UW-2E16) in the slot

**Note 2:** For SXB2 (CPU2 PCI-E 3.0X16) slot to work properly, please use the SMC-proprietary riser card (PN: RSC-R2UW-2E8R).

**Note 3:** CPU2 needs to be populated for PCIe SXB2 and SXB1B (lower left) slots to be functional.

**Note 3:** For the latest CPU/memory updates, please refer to our website at <http://www.supermicro.com/products/serverboard>.

## 5-7 Connector Definitions

### Power Connectors

A 24-pin main power supply connector (JPWR1), and two 8-pin CPU power connectors (JPWR2/JPWR3) are located on the serverboard. These power connectors meet the SSI EPS 12V specification and must be connected to your power supply to provide adequate power to the system. See the tables on the right for pin definitions.

**Warning:** To provide adequate power supply to the serverboard, be sure to connect the 24-pin ATX power (JPWR1), and the two 8-pin power connectors (JPWR2, JPWR3) to the power supply. Failure to do so may void the manufacturer warranty on your power supply and serverboard.

ATX Power 24-pin Connector Pin Definitions (JPWR1)			
Pin#	Definition	Pin #	Definition
13	+3.3V	1	+3.3V
14	-12V	2	+3.3V
15	COM	3	COM
16	PS_ON	4	+5V
17	COM	5	COM
18	COM	6	+5V
19	COM	7	COM
20	Res (NC)	8	PWR_OK
21	+5V	9	5VSB
22	+5V	10	+12V
23	+5V	11	+12V
24	COM	12	+3.3V

12V 8-pin Power Connector Pin Definitions	
Pins	Definition
1 through 4	Ground
5 through 8	+12V

(Required)

### Power Button

The Power Button connection is located on pins 1 and 2 of JF1. Momentarily contacting both pins will power on/off the system. This button can also be configured to function as a suspend button (with a setting in the BIOS - See Chapter 4). To turn off the power when the system is in suspend mode, press the button for 4 seconds or longer. Refer to the table on the right for pin definitions.

Power Button Pin Definitions (JF1)	
Pin#	Definition
1	Signal
2	Ground

### Reset Button

The Reset Button connection is located on pins 3 and 4 of JF1. Attach it to a hardware reset switch on the computer case. Refer to the table on the right for pin definitions.

Reset Button Pin Definitions (JF1)	
Pin#	Definition
3	Reset
4	Ground

### Power Fail LED

The Power Fail LED connection is located on pins 5 and 6 of JF1. Refer to the table on the right for pin definitions.

PWR Fail LED Pin Definitions (JF1)	
Pin#	Definition
5	3.3V
6	PWR Supply Fail

### Overheat (OH)/Fan Fail/PWR Fail/UID LED

Connect an LED cable to pins 7 and 8 of Front Control Panel to use the Overheat/Fan Fail/Power Fail and UID LED connections. The Red LED on pin 8 provides warnings of overheating, fan failure or power failure. The Blue LED on pin 7 works as the front panel UID LED indicator. Refer to the tables on the right for pin definitions.

OH/Fan Fail/ PWR Fail/Blue_ UID LED Pin Definitions (JF1)	
Pin#	Definition
7	Blue_UID LED
8	OH/Fan Fail/Power Fail

OH/Fan Fail/PWR Fail LED Status (Red LED)	
State	Definition
Off	Normal
On	Overheat
Flashing	Fan Fail

### NIC1/NIC2 LED Indicators

The NIC (Network Interface Controller) LED connection for LAN Port 1 is located on pins 11 and 12 of JF1, and for LAN Port 2 is on pins 9 and 10. Attach the NIC LED cables here to display network activity. Refer to the table on the right for pin definitions.

GLAN1/2 LED Pin Definitions (JF1)	
Pin#	Definition
9	NIC 2 Activity LED
10	NIC 2 Link LED
11	NIC 1 Activity LED
12	NIC 1 Link LED

### HDD/UID LED

The HDD LED connection is located on pins 13 and 14 of JF1. Attach a cable here to indicate HDD activity and UID status. See the table on the right for pin definitions.

HDD LED Pin Definitions (JF1)	
Pin#	Definition
13	UID LED
14	HD Active

### Power LED

The Power LED connection is located on pins 15 and 16 of JF1. Refer to the table on the right for pin definitions.

Power LED Pin Definitions (JF1)	
Pin#	Definition
15	3.3V
16	PWR LED

### NMI Button

The non-maskable interrupt button header is located on pins 19 and 20 of JF1. Refer to the table on the right for pin definitions.

NMI Button Pin Definitions (JF1)	
Pin#	Definition
19	Control
20	Ground

### Ethernet Ports

Two Ethernet ports (LAN1, LAN2) are located on the I/O backplane. These Ethernet ports support 10G LAN connections on the X10DRW-iT, and Gigabit LAN connections on the X10DRW-i. In addition, an IPMI\_Dedicated LAN that supports Gigabit LAN is located above USB 0/1 ports on the backplane. All Ethernet ports accept RJ45 type cables. Please refer to the LED Indicator Section for LAN LED information.

LAN Ports (LAN1/2) Pin Definition			
Pin#	Definition	Pin#	Definition
1	P2V5SB	10	SGND
2	TD0+	11	Act LED
3	TD0-	12	P3V3SB
4	TD1+	13	Link 100 LED (Yellow, +3V3SB)
5	TD1-	14	Link 1000 LED (Yellow, +3V3SB)
6	TD2+	15	Ground
7	TD2-	16	Ground
8	TD3+	17	Ground
9	TD3-	18	Ground

**Note:** NC indicates no connection.

### Chassis Intrusion

A Chassis Intrusion header is located at JL1 on the serverboard. Attach an appropriate cable from the chassis to inform you of a chassis intrusion when the chassis is opened.

Chassis Intrusion Pin Definitions	
Pin#	Definition
1	Intrusion Input
2	Ground

### Video Connection

A Video (VGA) port is located next to USB 0/1 on the I/O backplane. Refer to the serverboard layout below for the location.

### Universal Serial Bus (USB)

Four USB 3.0 ports (USB 0/1, USB 2/3) are located on the I/O backpanel. In addition, an internal USB header, located next to S-SATA0, also provides two USB 3.0 connections (USB 4/5) for front panel support. (Cables are not included). See the tables on the right and below for pin definitions.

BP USB (3.0) 0/1, 2/3 Pin Definitions	
Pin#	Description
1	VBUS
2	SSRX-
3	SSRX+
4	Ground
5	SSTX-
6	SSTX+
7	GND_DRAIN
8	D-
9	D+

Front Panel USB (3.0) 4/5 Pin Definitions			
Pin#	Definition	Pin#	Definition
1	+5V	2	+5V
3	USB_PN2	4	USB_PN3
5	USB_PP2	6	USB_PP3
7	Ground	8	Ground
9	Key	10	Ground

### TPM/Port 80 Header

A Trusted Platform Module/Port 80 header, located at JTPM1, provides TPM support and Port 80 connection. Use this header to enhance system performance and data security. See the table on the right for pin definitions.

Trusted Platform Module Header Pin Definitions (JTPM1)			
Pin#	Definition	Pin#	Definition
1	LCLK	2	GND
3	LFRAME	4	No Pin
5	LRESET	6	VCC5
7	LAD3	8	LAD2
9	VCC3	10	LAD1
11	LAD0	12	GND
13	RSV0	14	RSV1
15	SB3V	16	SERIRQ
17	GND	18	CLKRUN
19	LPCPD	20	RSV2



### Unit Identifier Switch/UID LED Indicator

A Unit Identifier (UID) switch is located on the I/O backplane, and two UID LED indicators are located on the serverboard. The rear UID LED (LED1) is located next to the UID switch. The front UID LED is located on pins 7 & 8 on the front control panel (JF1). When you press the UID switch, both rear and front UID LED indicators will be turned on. Press the UID switch again to turn off the LED indicators. The UID Indicators provide easy identification of a system unit that may be in need of service.

**Note:** UID can also be triggered via IPMI on the serverboard. For more information on IPMI, please refer to the IPMI User's Guide posted on our website @ <http://www.supermicro.com>.

UID Switch	
Pin#	Definition
1	Ground
2	Ground
3	Button In
4	Ground

UID LED Status	
Color/State	Status
Blue: On	Unit Identified

### Internal Speaker

The Internal Speaker (SP1) provides audible indications for various beep codes. See the table on the right for pin definitions. Refer to the layout below for the location of the Internal Buzzer.

Internal Buzzer Pin Definition		
Pin#	Definitions	
Pin 1	Pos. (+)	Beep In
Pin 2	Neg. (-)	Alarm Speaker

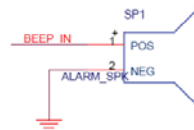

### Standby Power Header

The +5V Standby Power header is located at JSTBY1 on the serverboard. See the table on the right for pin definitions. (You must also have a card with a Standby Power connector and a cable to use this feature.)

Standby PWR Pin Definitions	
Pin#	Definition
1	+5V Standby
2	Ground
3	No Connection

### Power SMB (I<sup>2</sup>C) Connector

Power System Management Bus (I<sup>2</sup>C) connector (JP<sup>I<sup>2</sup>C</sup>1) monitors power supply, fan and system temperatures. See the table on the right for pin definitions.

PWR SMB Pin Definitions	
Pin#	Definition
1	Clock
2	Data
3	PMBUS_Alert
4	Ground
5	+3.3V

### IPMB

A System Management Bus header for IPMI 2.0 is located at JIPMB1. Connect the appropriate cable here to use the IPMB I<sup>2</sup>C connection on your system.

IPMB Header Pin Definitions	
Pin#	Definition
1	Data
2	Ground
3	Clock
4	No Connection

### Fan Headers

This serverboard has six system/CPU fan headers (Fan 1-Fan 4, Fan A and Fan B ) on the serverboard. All these 4-pin fans headers are backward compatible with the traditional 3-pin fans. However, fan speed control is available for 4-pin fans only. The fan speeds are controlled by Thermal Management via IPMI 2.0 interface. See the table on the right for pin definitions.

Fan Header Pin Definitions	
Pin#	Definition
1	Ground
2	+12V
3	Tachometer
4	PWR Modulation

### S-SGPIO and I-SGPIO 1/2 Headers

Three SGPIO (Serial Link General Purpose Input/Output) headers are located on the serverboard. I-SGPIO 1 supports I-SATA 0-3, and I-SGPIO 2 supports I-SATA 4/5. S-SGPIO is used for S-SATA 0-3. See the table on the right for pin definitions.

S-SGPIO & I-SGPIO 1/2 Headers Pin Definitions			
Pin#	Definition	Pin #	Definition
1	NC	2	Data
3	Ground	4	Data
5	Load	6	Ground
7	CLK	8	NC

**Note:** NC indicates no connection.

## 5-8 Jumper Settings

### Explanation of Jumpers

To modify the operation of the serverboard, jumpers can be used to choose between optional settings. Jumpers create shorts between two pins to change the function of the connector. Pin 1 is identified with a square solder pad on the printed circuit board. See the diagram at right for an example of jumping pins 1 and 2. Refer to the serverboard layout page for jumper locations.

**Note:** On two-pin jumpers, "Closed" means the jumper is on and "Open" means the jumper is off the pins.

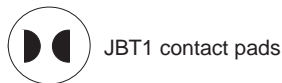
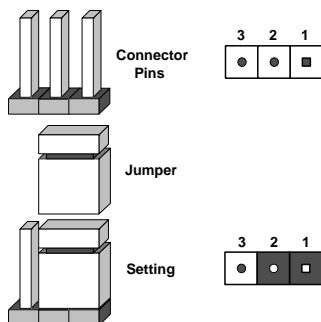

### CMOS Clear

JBT1 is used to clear CMOS, which will also clear any passwords. Instead of pins, this jumper consists of contact pads to prevent accidentally clearing the contents of CMOS.

#### To Clear CMOS

1. First power down the system and unplug the power cord(s). It is also recommended that you remove the onboard battery from the serverboard.
2. With the power disconnected, short the CMOS pads with a metal object such as a small screwdriver.
3. Remove the screwdriver (or shorting device).
4. Reconnect the power cord(s) and power on the system.

**Note 1.** For an ATX power supply, you must completely shut down the system, remove the AC power cord, and then short JBT1 to clear CMOS.

**Note 2.** Be sure to remove the onboard CMOS Battery before you short JBT1 to clear CMOS.

**Note 3.** Clearing CMOS will also clear all passwords.

**Note 4:** Do not use the PW ON connector to clear CMOS.

### LAN Enable/Disable

JPL1 enables or disables Gigabit\_LAN ports 1/2 on the X10DRW-i, and 10G\_LAN ports 1/2 on the X10DRW-iT. See the table on the right for jumper settings. The default setting is Enabled.

LAN Enable/Disable Jumper Settings (JPL1)	
Jumper Setting	Definition
Pins 1-2	Enabled (default)
Pins 2-3	Disabled

### Watch Dog Enable/Disable

Watch Dog (JWD1) is a system monitor that will reboot the system when a software application hangs. Close pins 1-2 to reset the system if an application hangs. Close pins 2-3 to generate a non-maskable interrupt signal for the application that hangs. See the table on the right for jumper settings. Watch Dog must also be enabled in the BIOS.

Watch Dog Enable/Disable Jumper Settings (JWD1)	
Jumper Setting	Definition
Pins 1-2	Reset
Pins 2-3	NMI
Open	Disabled

### VGA Enable

Jumper JPG1 allows the user to enable the onboard VGA connector. The default setting is on pins 1-2 to enable the connection. See the table on the right for jumper settings.

VGA Enable/Disable Jumper Settings (JPG1)	
Jumper Setting	Definition
Pins 1-2	Enabled
Pins 2-3	Disabled

### BMC Enable

Jumper JPB1 is used to enable or disable the embedded AST2400 BMC (Baseboard Management Controller) that provides IPMI 2.0/KVM support on the serverboard. See the table on the right for jumper settings.

BMC Enable/Disable Jumper Settings (JPB1)	
Jumper Setting	Definition
Pins 1-2	BMC Enable
Pins 2-3	Normal (Default)

### I<sup>2</sup>C Bus to PCI-E Slots

Use Jumpers JI<sup>2</sup>C1 and JI<sup>2</sup>C2 to connect the System Management Bus (I<sup>2</sup>C) to PCI-Express slots to improve PCI performance. These two jumpers are to be set at the same time. The default setting is on pins 2-3 to disable the connection for normal operations. See the table on the right for jumper settings.

I <sup>2</sup> C to PCI-E Jumper Setting	
Jumper Setting	Definition
Pins 1-2	Enabled
Pins 2-3	Disabled (Default)

### Manufacturer Mode Select

Close pin 2 and pin 3 of Jumper JPME2 to bypass SPI flash security and force the system to operate in the Manufacturer mode, which will allow the user to flash the system firmware from a host server for system setting modifications. See the table on the right for jumper settings.

ME Mode Select Jumper Settings	
Jumper Setting	Definition
1-2	Normal (Default)
2-3	Manufacture Mode

## 5-9 Onboard LED Indicators

### GLAN LEDs

The LAN ports are located on the IO Backplane on the serverboard. Each Ethernet LAN port has two LEDs. The yellow LED indicates activity. Link LED, located on the left side of the LAN port, may be green, amber or off indicating the speed of the connection. See the tables at right for more information.

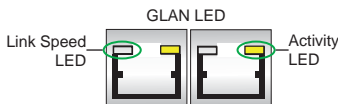

GLAN Activity Indicator (Right) LED Settings		
Color	Status	Definition
Off	No Connections	
Yellow	Flashing	Active

LAN Connection Speed Indicator (Left) LED Settings	
LED Color	Definition
Off	10 MHz
Green	100 MHz
Amber	1 GHz

### IPMI Dedicated LAN LEDs

In addition to LAN 1/LAN 2, an IPMI-dedicated LAN is located on the I/O Backplane of the serverboard. The amber LED on the right indicates activity, while the green LED on the left indicates the speed of the connection. See the tables at right for more information.

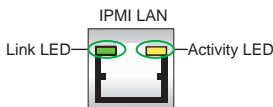

IPMI LAN Link/Speed LED (Left) & Activity LED (Right)		
Color	Status	Definition
Off	Off	No Connection
Green: Solid	Link/Speed (Left)	100 Mb/s
Amber Blinking	Activity (Right)	Active

### BMC Heartbeat LED

A BMC Heartbeat LED is located at LEDM1 on the serverboard. When LEDM1 is blinking, BMC functions normally. See the table at right for more information.

BMC Heartbeat LED States	
Color/State	Definition
Green: Blinking	BMC: Normal

### Onboard Power LED

An Onboard Power LED is located at LED2 on the serverboard. When this LED is on, the system is on. Be sure to turn off the system and unplug the power cord before removing or installing components. See the tables at right for more information.

Onboard PWR LED Indicator LED States	
LED Color	Definition
Off	System Off (PWR cable not connected)
Green	System On
Green: Flashing Quickly	ACPI S1 State

**Note:** Refer to Page 2-21 for information on the rear UID LED (LED1).

## 5-10 SATA Connections

### SATA 3.0 Ports

There are ten SATA 3.0 (I-SATA 0-5 & S-SATA0-3) on the serverboard. I-SATA ports are supported by the Intel PCH C612, and S-SATA ports are supported by the Intel SCU chip. These SATA ports provide serial-link signal connections, which are faster than the connections of Parallel ATA. See the table on the right for pin definitions.

SATA Connectors Pin Definitions	
Pin#	Signal
1	Ground
2	SATA_TXP
3	SATA_TXN
4	Ground
5	SATA_RXN
6	SATA_RXP
7	Ground

**Note:** For more information on SATA HostRAID configuration, please refer to the Intel SATA HostRAID User's Guide posted on our website @ <ftp://ftp.supermicro.com>.

## 5-11 Installing Software

The Supermicro ftp site contains drivers and utilities for your system at <ftp://ftp.supermicro.com>. Some of these must be installed, such as the chipset driver.

After accessing the ftp site, go into the CDR\_Images directory and locate the ISO file for your serverboard. Download this file to create a CD/DVD of the drivers and utilities it contains. (You may also use a utility to extract the ISO file if preferred.)

Another option is to go to the Supermicro Website at <http://www.supermicro.com/products/>. Find the product page for your serverboard here, where you may download individual drivers and utilities.

After creating a CD/DVD with the ISO files, insert the disk into the CD/DVD drive on your system and the display shown in Figure 5-6 should appear.

Figure 5-6. Driver/Tool Installation Display Screen

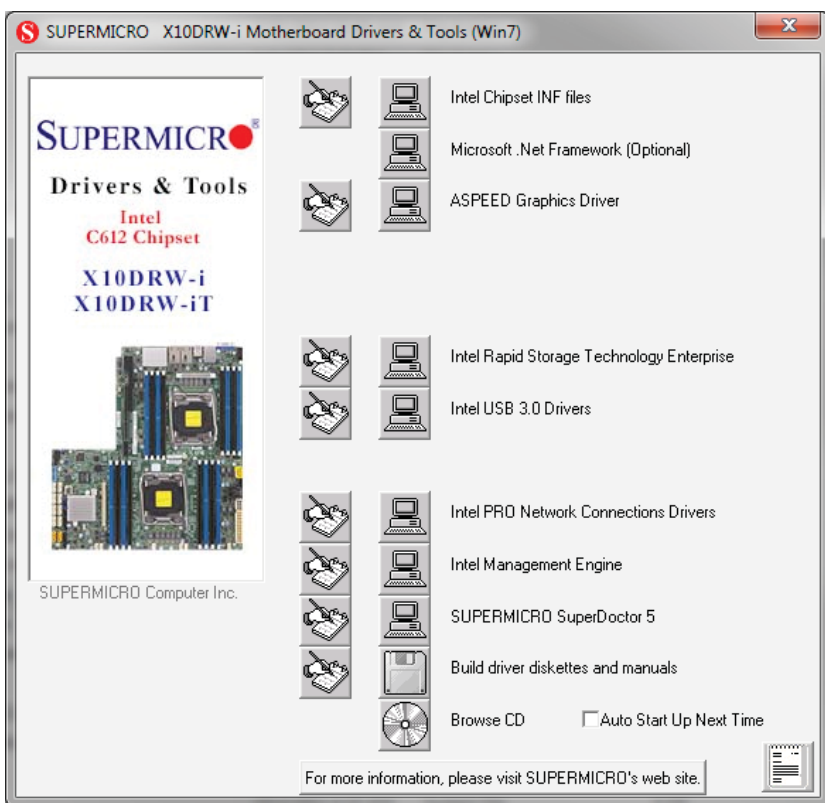



**Note:** Click the icons showing a hand writing on paper to view the readme files for each item. Click the computer icons to the right of these items to install each item (from top to the bottom) one at a time. **After installing each item, you must re-boot the system before moving on to the next item on the list.** The bottom icon with a CD on it allows you to view the entire contents.

## SuperDoctor 5

The Supermicro SuperDoctor® 5 is a hardware and operating system services monitoring program that functions in a command-line or web-based interface in Windows and Linux operating systems. The program monitors system health information such as CPU temperature, system voltages, system power consumption, fan speed, and provides alerts via email or Simple Network Management Protocol (SNMP).

SuperDoctor 5 comes in local and remote management versions and can be used with Nagios to maximize your system monitoring needs. With SuperDoctor 5 Management Server (SSM Server), you can remotely control power on/off and reset chassis intrusion for multiple systems with SuperDoctor 5 or IPMI. SD5 Management Server monitors HTTP, FTP, and SMTP services to optimize the efficiency of your operation.

**Note:** The default User Name and Password for SuperDoctor 5 is admin / admin.

**Figure 5-7. SuperDoctor 5 Interface Display Screen (Health Information)**



Figure 5-8. SuperDoctor 5 Interface Display Screen (Remote Control)

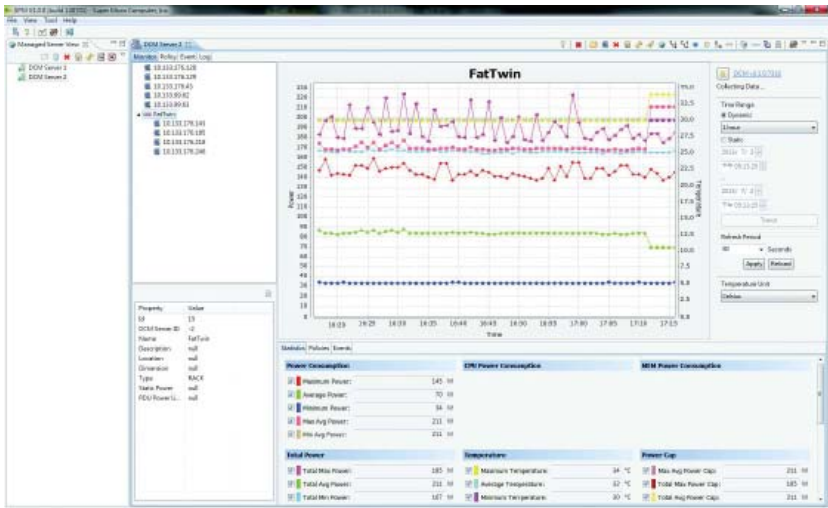

**Note:** The SuperDoctor 5 program and User's Manual can be downloaded from the Supermicro web site at [http://www.supermicro.com/products/nfo/sms\\_sd5.cfm](http://www.supermicro.com/products/nfo/sms_sd5.cfm). For Linux, we recommend that you use the SuperDoctor II application instead.

## 5-12 Serverboard Battery

**Caution:** There is a danger of explosion if the onboard battery is installed upside down, which will reverse its polarities (see Figure 5-x). This battery must be replaced only with the same or an equivalent type recommended by the manufacturer (CR2032). Dispose of used batteries according to the manufacturer's instructions.

**Figure 5-9. Installing the Onboard Battery**

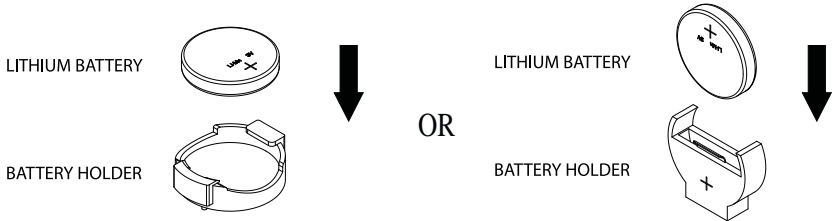

Please handle used batteries carefully. Do not damage the battery in any way; a damaged battery may release hazardous materials into the environment. Do not discard a used battery in the garbage or a public landfill. Please comply with the regulations set up by your local hazardous waste management agency to dispose of your used battery properly.

**Notes**

## Chapter 6

### Advanced Chassis Setup

This chapter covers the steps required to install components and perform maintenance on the SC815TQ-R706WB chassis. For component installation, follow the steps in the order given to eliminate the most common problems encountered. If some steps are unnecessary, skip ahead to the next step.

**Tools Required:** The only tool you will need to install components and perform maintenance is a Philips screwdriver.

#### 6-1 Static-Sensitive Devices

Electrostatic discharge (ESD) can damage electronic components. To prevent damage to any printed circuit boards (PCBs), it is important to handle them very carefully. The following measures are generally sufficient to protect your equipment from ESD damage.

##### Precautions

- Use a grounded wrist strap designed to prevent static discharge.
- Touch a grounded metal object before removing any board from its antistatic bag.
- Handle a board by its edges only; do not touch its components, peripheral chips, memory modules or gold contacts.
- When handling chips or modules, avoid touching their pins.
- Put the serverboard, add-on cards and peripherals back into their antistatic bags when not in use.
- For grounding purposes, make sure your computer chassis provides excellent conductivity between the power supply, the case, the mounting fasteners and the serverboard.

Figure 6-1. Chassis: Front and Rear Views

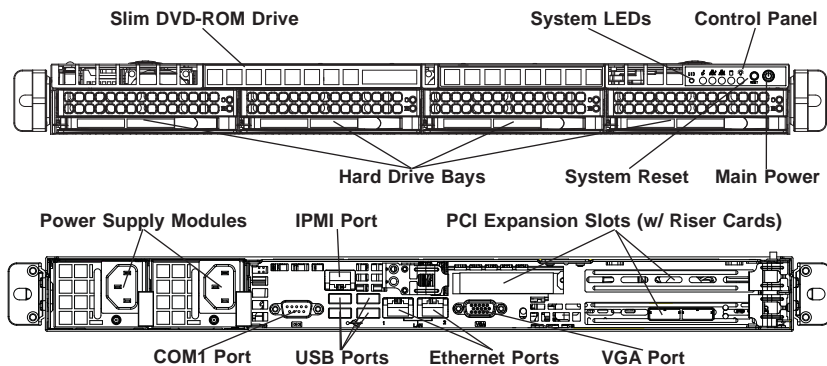

## 6-2 Control Panel

The control panel (located on the front of the chassis) must be connected to the JF1 connector on the serverboard to provide you with system status indications. These wires have been bundled together as a ribbon cable to simplify the connection.

Connect the cable from JF1 on the serverboard to the appropriate header on the Control Panel PCB (printed circuit board). Make sure the red wire plugs into pin 1 on both connectors. Pull all excess cabling out of the airflow path.

The control panel LEDs inform you of system status. See "Chapter 3: System Interface" for details on the LEDs and the control panel buttons. Details on JF1 can be found in "Chapter 5: Advanced Serverboard Setup."

## 6-3 System Fans

Five 4-cm heavy duty counter-rotating fans provide the cooling for the SuperServer 6018R-WTR(T). Each fan unit is actually made up of two fans joined back-to-back, which rotate in opposite directions. This counter-rotating action generates exceptional airflow and works to dampen vibration levels. It is very important that the chassis top cover is properly installed and making a good seal in order for the cooling air to circulate properly through the chassis and cool the components. See Figure 6-2.

Figure 6-2. System Cooling Fans

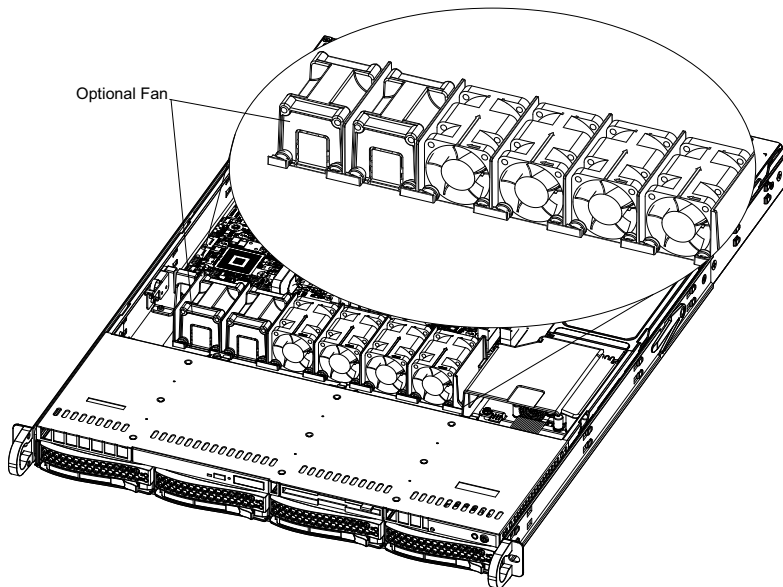

## System Fan Failure

Fan speed is controlled by system temperature via a BIOS setting. If a fan fails, the remaining fan will ramp up to full speed and the overheat/fan fail LED on the control panel will turn on. Replace any failed fan at your earliest convenience with the same type and model (the system can continue to run with a failed fan).

Remove the top chassis cover while the system is still running to determine which of the fans has failed. Then power down the system before replacing a fan. Removing the power cords is also recommended as a safety precaution.

These fans are NOT redundant, hot-plug and must be replaced when they fail.

### **Replacing System Fans**

1. After determining which fan has failed, turn off the power to the system.
2. Unplug the fan cable from the serverboard and remove the failed fan from the chassis.
3. Replace the failed fan with an identical 4-cm, 12 volt fan (available from Supermicro: p/n FAN-0086L4).
4. Push the new fan into the vacant space in the housing while making sure the arrows on the top of the fan (indicating air direction) point in the same direction as the arrows on the other fans.

5. Reposition the fan housing back over the two mounting posts in the chassis, then reconnect the fan wires to the same chassis fan headers you removed them from.
6. Power up the system and check that the fan is working properly and that the LED on the control panel has turned off. Finish by replacing the chassis cover.

## 6-4 Drive Bay Installation/Removal

### Removing the Front Bezel

If your system has a front bezel (optional) attached to the chassis, you must first remove it to gain access to the drive bays. To remove the bezel, first unlock the front of the chassis then press the release knob (see Figure 6-3). Carefully remove the bezel with both hands. A filter located within the bezel can be removed for replacement/cleaning. It is recommended that you keep a maintenance log of filter cleaning/replacement, since its condition will affect the airflow throughout the whole system.

Figure 6-3. Removing the Front Bezel

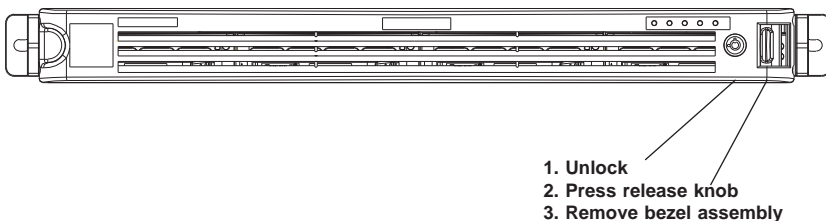

### Accessing the Drive Bays

**Hard Drives:** Because of their hotswap capability, you do not need to access the inside of the chassis or power down the system to install or replace SATA drives. Proceed to the next section for instructions.

**DVD-ROM Drive:** For installing/removing a DVD-ROM drive, you will need to gain access to the inside of the SuperServer 6018R-WTR(T) by removing the top cover of the chassis. Proceed to the "DVD-ROM Drive Installation" section later in this chapter for instructions.

**Note:** Only a "slim" DVD-ROM drive will fit into the SuperServer 6018R-WTR(T).



## Hard Drive Installation

The hard drives are mounted in drive carriers to simplify their installation and removal from the chassis. These carriers also help promote proper airflow for the drive bays. For this reason, even empty carriers without drives installed must remain in the chassis.

### *Mounting a Hard Drive in a Drive Carrier*

1. Insert a drive into the carrier with the printed circuit board side facing down so that the mounting holes align with those in the carrier.
2. Secure the drive to the carrier with six screws, as shown in Figure 6-4.

**Figure 6-4. Mounting a Hard Drive in a Carrier**

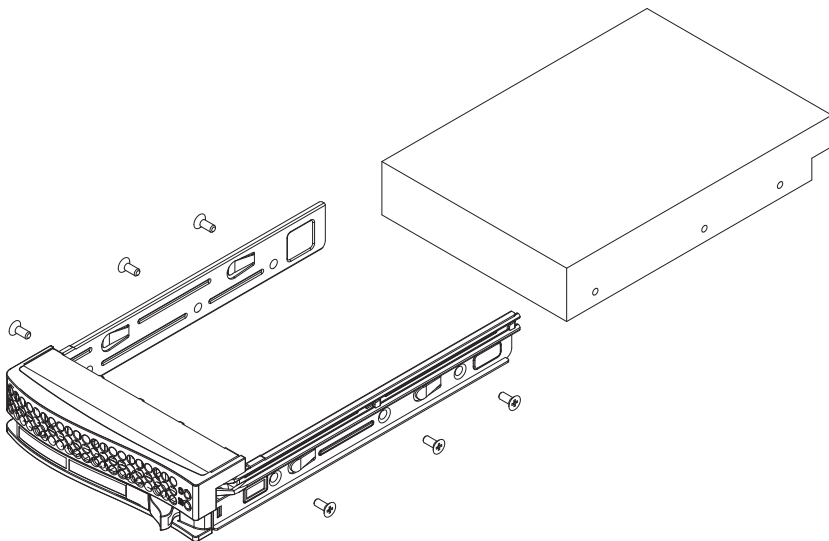

**Caution:** Use caution when working around the hard drive backplane. Do not touch the backplane with any metal objects and make sure no ribbon cables touch the backplane or obstruct the holes, which aid in proper airflow.

**Caution:** Regardless of how many hard drives are installed, all drive carriers must remain in the drive bays to maintain proper airflow.

### ***Installing/Removing a Hard Drive***

1. To remove a carrier, push the release button located beside the drive LEDs.
2. Swing the colored handle fully out and use it to pull the unit straight out (see Figure 6-5).

**Note:** Your operating system must have RAID support to enable the hot-plug capability of the hard drives.

**Figure 6-5. Removing a Hard Drive from the Server**

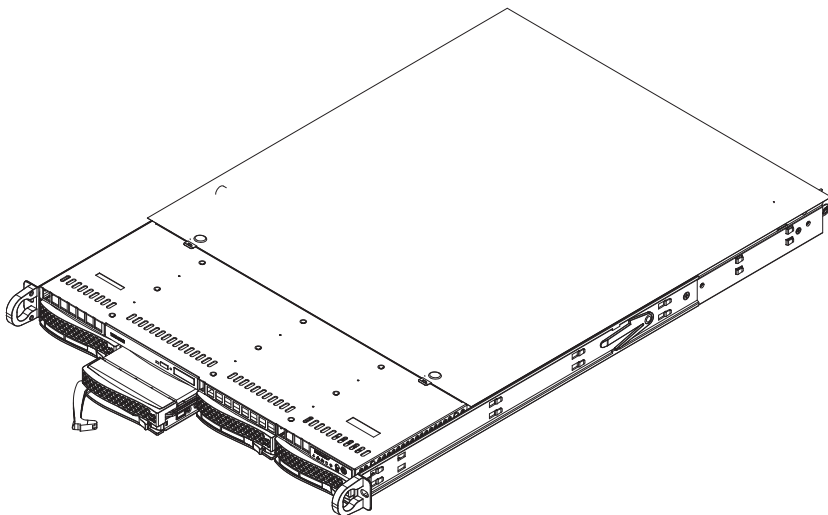

**Warning:** Enterprise level hard disk drives are recommended for use in Supermicro chassis and servers. For information on recommended HDDs, visit the Supermicro Web site at <http://www.supermicro.com/products/nfo/files/storage/SAS-CompList.pdf>

### **DVD-ROM Drive Installation**

The top cover of the chassis must be opened to gain full access to the DVD-ROM drive bay. The SuperServer 6018R-WTR(T) accommodates only slim-line DVD-ROM drives. Side mounting brackets are needed to mount a slim-line DVD-ROM drive in the SuperServer 6018R-WTR(T) server. You must power down the system before installing or removing a DVD-ROM drive.

**Removing the Chassis Cover**

1. Grasp the two handles on either side and pull the unit straight out until it locks (you will hear a "click").
2. Depress the two buttons on the top of the chassis to release the top cover and at the same time, push the cover away from you until it stops. You can then lift the top cover from the chassis to gain full access to the inside of the server.

**Removing/Installing a Drive**

1. With the chassis cover removed, unplug the power and data cables from the drive you want to remove.
2. Locate the locking tab at the rear of the drive. It will be on the left side of the drive when viewed from the front of the chassis.
3. Pull the tab away from the drive and push the drive unit out the front of the chassis.
4. Add a new drive by following this procedure in reverse order. You may hear a faint \*click\* of the locking tab when the drive is fully inserted.
5. Remember to reconnect the data and power cables to the drive before replacing the chassis cover and restoring power to the system.

## 6-5 Power Supply

The SuperServer 6018R-WTR(T) has redundant 700/750 Watt (Part# PWS-706P-1R) consisting of two hot-plug power modules. The power supply modules have an auto-switching capability, which enables them to automatically sense and operate with a 100V - 240V input voltage.

**Redundant Power Supply Failure**

If either of the two redundant power supply modules fail, the other module will take the full load and allow the system to continue operation without interruption. The Universal Information LED on the control panel will blink slowly and remain so until the failed module has been replaced. Replacement modules can be ordered directly from Supermicro (see contact information in the Preface). The power supply modules have a hot-swap capability, meaning you can replace the failed module without powering down the system.

### **Replacing the Power Supply**

You do not need to shut down the system to replace a power supply module. The redundant feature will keep the system up and running while you replace the failed hot-swap module. Replace with the same model, which can be ordered directly from Supermicro (see Contact Information in the Preface).

1. First unplug the power cord from the failed power supply module (with RED LED lit up).
2. To remove the failed power module, push the release tab (on the back of the power supply) to the side and then pull the module straight out (see Figure 6-6).
3. The power supply wiring was designed to detach automatically when the module is pulled from the chassis.
4. Replace the failed power module with another power supply module.
5. Simply push the new power supply module into the power bay until you hear a click.
6. Finish by plugging the AC power cord back into the module, then sure the GREEN LED lights up and the power supply fans are rotating.

**Figure 6-6. Removing/Replacing the Power Supply**

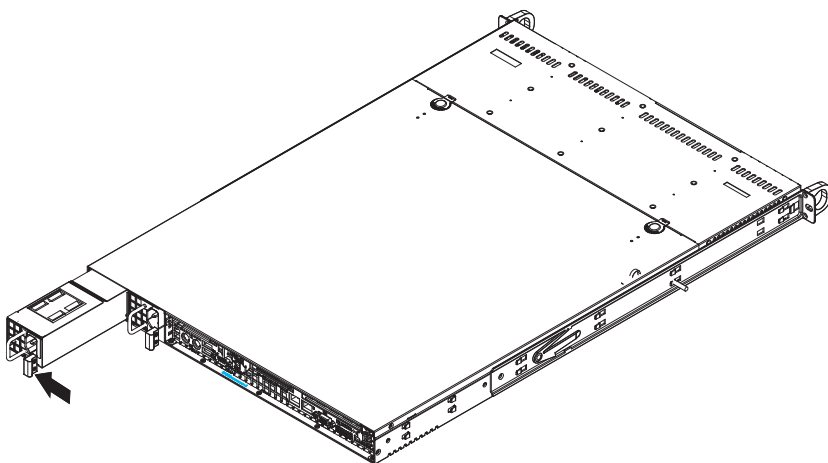

## Chapter 7

# BIOS

### 7-1 Introduction

This chapter describes the AMI BIOS Setup utility for the X10DRW-i(T). It also provides the instructions on how to navigate the AMI BIOS Setup utility screens. The AMI ROM BIOS is stored in a Flash EEPROM and can be easily updated.

#### Starting BIOS Setup Utility

To enter the AMI BIOS Setup utility screens, press the <Del> key while the system is booting up.

**Note:** In most cases, the <Del> key is used to invoke the AMI BIOS setup screen. There are a few cases when other keys are used, such as <F3>, <F4>, etc.

Each main BIOS menu option is described in this manual. The Main BIOS setup menu screen has two main frames. The left frame displays all the options that can be configured. Grayed-out options cannot be configured. Options in blue can be configured by the user. The right frame displays the key legend. Above the key legend is an area reserved for informational text. When an option is selected in the left frame, it is highlighted in white. Often informational text will accompany it.

**Note:** The AMI BIOS has default informational messages built in. The manufacturer retains the option to include, omit, or change any of these informational messages.

The AMI BIOS Setup utility uses a key-based navigation system called "hot keys." Most of the AMI BIOS setup utility "hot keys" can be used at any time during setup navigation. These keys include <F3>, <F4>, <Enter>, <ESC>, arrow keys, etc.

**Note 1:** Options printed in **Bold** are default settings.

**Note 2:** <F3> is used to load optimal default settings. <F4> is used to save the settings and exit the setup utility.

## How To Change the Configuration Data

The configuration data that determines the system parameters may be changed by entering the AMI BIOS Setup utility. This Setup utility can be accessed by pressing <Delete> at the appropriate time during system boot.

**Note:** For AMI UEFI BIOS Recovery, please refer to the UEFI BIOS Recovery User Guide posted @<http://www.supermicro.com/support/manuals/>.

## Starting the Setup Utility

Normally, the only visible Power-On Self-Test (POST) routine is the memory test. As the memory is being tested, press the <Delete> key to enter the main menu of the AMI BIOS Setup utility. From the main menu, you can access the other setup screens. An AMI BIOS identification string is displayed at the left bottom corner of the screen below the copyright message.

**Warning!** Do not upgrade the BIOS unless your system has a BIOS-related issue. Flashing the wrong BIOS can cause irreparable damage to the system. In no event shall the manufacturer be liable for direct, indirect, special, incidental, or consequential damage arising from a BIOS update. If you have to update the BIOS, do not shut down or reset the system while the BIOS is being updated to avoid possible boot failure.

## 7-2 Main Setup

When you first enter the AMI BIOS Setup utility, you will enter the Main setup screen. You can always return to the Main setup screen by selecting the Main tab on the top of the screen. The Main BIOS Setup screen is shown below.

The AMI BIOS main menu displays the following information:

### System Time/System Date

Use this option to change the system time and date. Highlight *System Time* or *System Date* using the arrow keys. Enter new values through the keyboard and press <Enter>. Press the <Tab> key to move between fields. The date must be entered in Day MM/DD/YY format. The time is entered in HH:MM:SS format. (**Note:** The time is in the 24-hour format. For example, 5:30 P.M. appears as 17:30:00.)

### Supermicro X10DRi-T

#### Version

This item displays the version of the BIOS used in the system.

#### Build Date

This item displays the day when this version of BIOS was built.

## Memory Information

### Total Memory

This displays the amount of memory that is available in the system.

## 7-3 Advanced Setup Configurations

Use the arrow keys to select Advanced and press <Enter> to access the following submenu items:

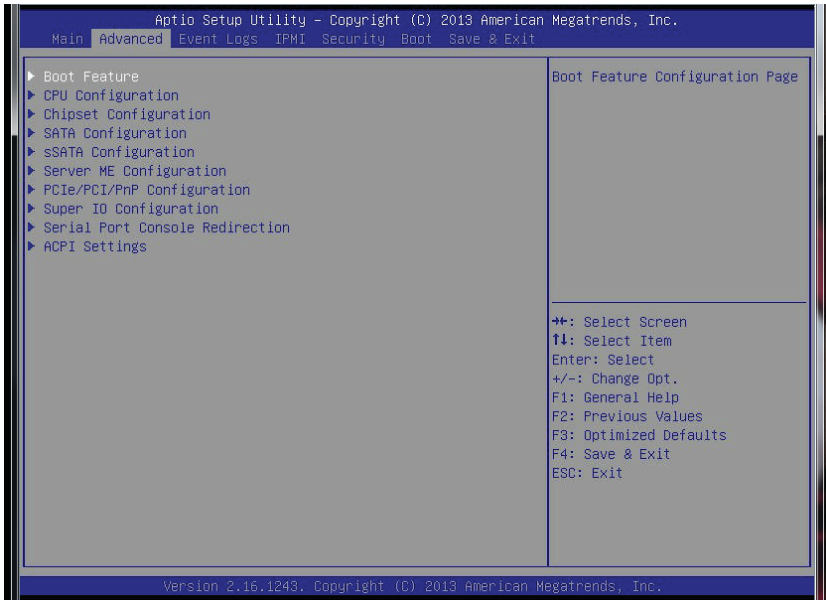

### ► Boot Feature

#### Quiet Boot

Use this feature to select the bootup screen display between POST messages or the OEM logo. Select Disabled to display the POST messages. Select Enabled to display the OEM logo. The default setting is **Enabled**.

#### AddOn ROM Display Mode

This sets the display mode for the Option ROM. Select Keep Current to use the current AddOn ROM Display setting. Select Force BIOS to use the Option ROM display mode set by the system BIOS. The options are **Force BIOS** and Keep Current.

**Bootup Num-Lock**

Use this feature to set the Power-on state for the Numlock key. The options are Off and **On**.

**Wait For 'F1' If Error**

If this feature is set to **Enabled**, the system will wait until the 'F1' key is pressed when an error occurs. The options are Disabled and **Enabled**.

**Interrupt 19 Capture**

Interrupt 19 is the software interrupt that handles disk boot. When this item is set to Enabled, the ROM BIOS of the host adaptors will "capture" Interrupt 19 at boot up and allow the drives that are attached to these host adaptors to function as bootable disks. If this item is set to Disabled, the ROM BIOS of the host adaptors will not capture Interrupt 19, and the drives attached to these adaptors will not function as bootable devices. The options are **Enabled** and Disabled.

**Re-try Boot**

If this item is enabled, the BIOS will automatically reboot the system from a specified boot device again after its initial boot failed. The options are **Disabled**, Legacy Boot, and EFI Boot.

**Power Configuration****Watch Dog Function**

If enabled, the Watch Dog timer will reboot the system when it is not active for more than 5 minutes. The options are Enabled and **Disabled**.

**Power Button Function**

If this feature is set to Instant Off, the system will power off immediately as soon as the user presses the power button. Select 4 Second Override for the system to power off when the user presses the power button for 4 seconds or longer. The options are **Instant Off** and 4 Seconds Override.

**Restore on AC Power Loss**

Use this feature to set the power state after a power outage. Select Stay Off for the system power to remain off after a power loss. Select Power On for the system power to be turned on after a power loss. Select Last State to allow the system to resume its last power state before a power loss. The options are Power On, Stay Off and **Last State**.



## ► CPU Configuration

This submenu displays the information of the CPU as detected by the BIOS. It also allows the user to configure the CPU settings.

### ► Socket 1 CPU Information/Socket 2 CPU Information

This submenu displays the following information regarding the CPU installed in Socket 1 or Socket 2.

- Type of CPU
- CPU Signature
- Microcode Patch
- CPU Stepping
- Maximum CPU Speed
- Minimum CPU Speed
- Processor Cores
- Intel HT(Hyper-Threading) Technology
- Intel VT-x (Virtualization) Technology
- Intel SMX (Trusted Execution) Technology
- L1 Data Cache
- L1 Code Cache
- L2 Cache
- L3 Cache

#### **CPU Speed**

This item displays the speed of the CPU installed in a socket specified.

#### **64-bit**

This item indicates if the CPU installed in the socket specified by the user supports 64-bit technology.

#### **Clock Spread Spectrum**

Select Enabled to enable Clock Spectrum support which allows the BIOS to monitor and attempt to reduce the level of Electromagnetic Interference caused by the components whenever needed. The options are **Disabled** and Enabled.

### **RTID (Record Types IDs)**

This feature displays the total number of Record Type IDs for local and remote pools. The options are **Optimal** and Alternate.

### **Hyper-threading**

Select Enabled to support Intel Hyper-threading Technology to enhance CPU performance. The options are **Enabled** and Disabled.

### **Active Processor Cores**

Set to Enabled to use a processor's Second Core and beyond. (Please refer to Intel's web site for more information.) The options are **All**, 1, 2, 4, 6, and 8.

### **Limit CPUID Maximum**

This feature allows the user to set the maximum CPU ID value. Enable this function to boot the legacy operating systems that cannot support processors with extended CPUID functions. The options are Enabled and **Disabled** (for the Windows OS).

### **Execute-Disable Bit Capability (Available if supported by the OS & the CPU)**

Set to Enabled to enable the Execute Disable Bit which will allow the processor to designate areas in the system memory where an application code can execute and where it cannot, thus preventing a worm or a virus from flooding illegal codes to overwhelm the processor or damage the system during an attack. The default is **Enabled**. (Refer to Intel and Microsoft Web Sites for more information.)

### **Intel® AES-NI**

Select Enable to use the Intel Advanced Encryption Standard (AES) New Instructions (NI) to ensure data security. The options are **Enabled** and Disabled.

### **MLC Streamer Prefetcher (Available when supported by the CPU)**

If set to Enabled, the MLC (mid-level cache) streamer prefetcher will prefetch streams of data and instructions from the main memory to the L2 cache to improve CPU performance. The options are Disabled and **Enabled**.

### **MLC Spatial Prefetcher (Available when supported by the CPU)**

If this feature is set to Disabled, The CPU prefetches the cache line for 64 bytes. If this feature is set to Enabled the CPU fetches both cache lines for 128 bytes as comprised. The options are Disabled and **Enabled**.

---

**DCU Streamer Prefetcher (Available when supported by the CPU)**

Select Enabled to support Data Cache Unite (DCU) prefetch to speed up data accessing and processing in the DCU to enhance CPU performance. The options are Disabled and **Enabled**.

**DCU IP Prefetcher**

Select Enabled for DCU (Data Cache Unit) IP Prefetcher support, which will prefetch IP addresses to enhance network connectivity and system performance. The options are **Enabled** and Disabled.

**Intel® Virtualization Technology (Available when supported by the CPU)**

Select Enabled to support Intel Virtualization Technology, which will allow one platform to run multiple operating systems and applications in independent partitions, creating multiple "virtual" systems in one physical computer. The options are **Enabled** and Disabled.

**Note:** If there is any change to this setting, you will need to power off and reboot the system for the change to take effect. Please refer to Intel's website for detailed information.

**► CPU Power Management Configuration**

This submenu allows the user to configure the following CPU Power Management settings.

**Power Technology**

Select Energy Efficiency to support power-saving mode. Select Custom to customize system power settings. Select Disabled to disable power-saving settings. The options are Disabled, **Energy Efficient**, and Custom. If the option is set to Custom, the following items will display:

**EIST (Available when Power Technology is set to Custom)**

EIST (Enhanced Intel SpeedStep Technology) allows the system to automatically adjust processor voltage and core frequency to reduce power consumption and heat dissipation. The options are Disabled (GV3 Disabled), and **Enabled (GV3 Enabled)**. (**Note:** GV3 is Intel Speedstep support used on older platforms. Please refer to Intel's website for detailed information.)

**Turbo Mode (Available when Power Technology is set to Custom)**

Select Enabled to use the Turbo Mode to boost system performance. The options are **Enabled** and Disabled.

### **C1E Support (Available when Power Technology is set to Custom)**

Select Enabled to enable Enhanced C1 Power State to boost system performance. The options are **Enabled** and Disabled.

### **CPU C3 Report (Available when Power Technology is set to Custom)**

Select Enabled to allow the BIOS to report the CPU C3 State (ACPI C2) to the operating system. During the CPU C3 State, the CPU clock generator is turned off. The options are Enabled and **Disabled**.

### **CPU C6 Report (Available when Power Technology is set to Custom)**

Select Enabled to allow the BIOS to report the CPU C6 State (ACPI C3) to the operating system. During the CPU C6 State, the power to all caches is turned off. The options are **Enabled** and Disabled.

### **CPU C7 Report (Available when Power Technology is set to Custom)**

Select Enabled to allow the BIOS to report the CPU C7 State (ACPI C3) to the operating system. CPU C7 State is a processor-specific low C-State. The options are **Enabled** and Disabled.

### **Package C-State limit (Available when Power Technology is set to Custom)**

This feature allows the user to set the limit on the C-State package register. The options are C0, C2, **C6**, and No Limit.

### **Energy Performance Bias**

Use this feature to select an appropriate fan setting to achieve maximum system performance (with maximum cooling) or maximum energy efficiency (with maximum power saving). The fan speeds are controlled by the firmware management via IPMI 2.0. The options are Performance, **Balanced Performance**, Balanced Energy, and Energy Efficient.

### **Factory Long Duration Power Limit**

This item displays the power limit (in watts) set by the manufacturer during which long duration power is maintained.

### **Long Duration Power Limit**

This item displays the power limit (in watts) set by the user during which long duration power is maintained. The default setting is **0**.

### **Factory Long Duration Maintained**

This item displays the period of time (in seconds) set by the manufacturer during which long duration power is maintained.

### **Long Duration Maintained**

This item displays the period of time (in seconds) during which long duration power is maintained. The default setting is **0**.

### **Recommended Short Duration Power Limit**

This item displays the short duration power settings (in watts) recommended by the manufacturer.

### **Short Duration Power Limit**

During Turbo Mode, the system may consume more power than the default power setting set for a processor, and thus, exceeds the Short Duration Power limit. By increasing this value, the processor can provide better performance during a short period. This item displays the time period during which short duration power is maintained. The default setting is **0**.

## **► Chipset Configuration**

### **► North Bridge**

This feature allows the user to configure the settings for the Intel North Bridge.

### **► Integrated IO Configuration**

#### **Intel® VT-d**

Select Enabled to enable Intel Virtualization Technology support for Direct I/O VT-d by reporting the I/O device assignments to the VMM (Virtual Machine Monitor) through the DMAR ACPI Tables. This feature offers fully-protected I/O resource sharing across Intel platforms, providing greater reliability, security and availability in networking and data-sharing. The options are **Enabled** and Disabled.

#### **Ageing Timer Rollover**

Select Disabled to allow the BIOS to determine how long the system should wait before reallocating resources to PCI-E devices for data transferring when a deadlock occurs. Select 32 us for the BIOS to wait for 32 us second before reallocating system resources for use of PCI-E data transferring when a deadlock occurs. The options are Disabled, 32 us, **128 us**, and 512 us.

**Intel® I/OAT**

Select Enabled to enable Intel I/OAT (I/O Acceleration Technology), which will significantly reduce CPU overhead by leveraging CPU architectural improvements and freeing the system resource up for other tasks. The options are Disabled and **Enabled**.

**DCA Support**

Select Enabled to use Intel's DCA (Direct Cache Access) Technology to improve data transfer efficiency. The default is **Enabled** and can not be changed.

**MMCFG Base**

Use this feature to select the default value for the PCI MMIO (Memory-Mapped IO) Base Address. The lower the value, the less available the system memory will be in a 32-bit OS environment. The options are **0x80000000**, 0xA0000000 and 0xC0000000.

**IIO 1 PCIe Port Bifurcation Control/IIO 2 PCIe Port Bifurcation Control**

This submenu configures the following IO PCIe Port Bifurcation Control settings for IIO 1 PCIe ports to determine how the available PCI-Express lanes to be distributed between the PCI-Exp. Root Ports.

**CPU1 Slot4 PCI-E 3.0 x8 Link Speed**

This feature allows the user to set the PCI-Exp bus speed for the slot specified above. The options are Gen1 (Generation 1), Gen2 and **Gen3**.

**CPU1 Slot6 PCI-E 3.0 x8 Link Speed**

This feature allows the user to set the PCI-Exp bus speed for the slot specified above. The options are Gen1 (Generation 1), Gen2 and **Gen3**.

**► QPI Configuration****Current QPI Link**

This item displays the current status of the QPI Link.

**Current QPI Frequency**

This item displays the current frequency of the QPI Link.

**Isoc**

Select Enabled to enable Isynchronous support to meet QoS (Quality of Service) requirements. This feature is especially important for virtualization technology. The options are **Disabled** and Enabled.

---

### **QPI (Quick Path Interconnect) Link Speed Mode**

Use this feature to select data transfer speed for QPI Link connections. The options are **Fast** and Slow.

### **QPI Link Frequency Select**

Use this feature to select the desired QPI frequency. The options are **Auto**, 6.4 GT/s, 7.2 GT/s, and 8.0 GT/s.

#### **►Memory Configuration**

- **Current Memory Mode:** This item displays the current memory mode.
- **Current Memory Speed:** This item displays the current memory speed.
- **Mirroring:** This item displays if memory mirroring is supported by the serverboard.
- **Sparing:** This item displays if memory sparing can be supported by the serverboard.

#### **►DIMM Information**

##### **CPU Socket 1 DIMM Information/ CPU Socket 2 DIMM Information**

The status of the memory modules detected by the BIOS will be displayed.

### **Memory Mode**

When Independent is selected, all DIMMs are available to the operating system. When Mirroring is selected, the serverboard maintains two identical copies of all data in memory for data backup. When Lockstep is selected, the serverboard uses two areas of memory to run the same set of operations in parallel. The options are **Independent**, Mirroring, and Lockstep.

### **DRAM RAPL Mode**

RAPL (Running Average Power Limit) provides mechanisms to enforce power consumption limits on supported processors. The options are DRAM RAPL MODE0 , **DRAM RAPL MODE1**, and Disabled.

### **DDR Speed**

Use this feature to force a DDR4 memory module to run at a frequency other than what is specified by the manufacturer. The options are **Auto**, Force DDR4-800, Force DDR4-1066, Force DDR4-1333, Force DDR4-1600 and Force SPD.

### Channel Interleaving

This feature selects from the different channel interleaving methods. The options are **Auto**, 1 Way, 2 Way, 3, Way, and 4 Way.

### Rank Interleaving

This feature allows the user to select a rank memory interleaving method. The options are **Auto**, 1 Way, 2 Way, 4, Way, and 8 Way.

### Patrol Scrub

Patrol Scrubbing is a process that allows the CPU to correct correctable memory errors detected on a memory module and send the correction to the requestor (the original source). When this item is set to Enabled, the IO hub will read and write back one cache line every 16K cycles if there is no delay caused by internal processing. By using this method, roughly 64 GB of memory behind the IO hub will be scrubbed every day. The options are **Enabled** and Disabled.

### Demand Scrub

Demand Scrubbing is a process that allows the CPU to correct correctable memory errors found on a memory module. When the CPU or I/O issues a demand-read command, and the read data from memory turns out to be a correctable error, then the error is corrected and sent to the requestor (the original source). Memory will be updated as well. Select Enabled to use Demand Scrubbing for ECC memory correction. The options are Enabled and **Disabled**.

### Data Scrambling

Select Enabled to enable data scrambling to ensure data security and integrity. The options are Disabled and **Enabled**.

### Device Tagging

Select Enabled to support device tagging. The options are **Disabled** and Enabled.

### Thermal Throttling

Throttling improves reliability and reduces power consumption in the processor via automatic voltage control during processor idle states. The options are Disabled and **CLTT** (Closed Loop Thermal Throttling).



## ► South Bridge

This feature allows the user to configure the settings for the Intel PCH chip.

### **PCH Information**

This feature displays the following PCH information.

**Name:** This item displays the name of the PCH chip.

**Stepping:** This item displays the PCH stepping.

**USB Devices:** This item displays the USB devices detected by the BIOS.

### **All USB Devices**

This feature enables all USB ports/devices. The options are Disabled and **Enabled**. (If set to Enabled, EHCI Controller 1 and Controller 2 will appear.)

### **EHCI Controller 1/EHCI Controller 2 (Available when All USB Devices is set to Enabled)**

Select Enabled to enable EHCI (Enhanced Host Controller Interface) Controller 1 or Controller 2 to enhance system performance. The options are Disabled and **Enabled**.

### **Legacy USB Support (Available when USB Functions is not Disabled)**

Select Enabled to support legacy USB devices. Select Auto to enable legacy support if a legacy USB device is present. Select Disabled to have USB devices available for EFI (Extensive Firmware Interface) applications only. The settings are Disabled, **Enabled** and Auto.

### **Port 60/64 Emulation**

Select Enabled to enable I/O port 60h/64h emulation support for the legacy USB keyboard so that it can be fully supported by the operating systems that does not recognize a USB device. The options are Disabled and **Enabled**.

### **EHCI Hand-Off**

This item is for operating systems that do not support Enhanced Host Controller Interface (EHCI) hand-off. When enabled, EHCI ownership change will be claimed by the EHCI driver. The options are **Disabled** and Enabled.

## ► SATA Configuration

When this submenu is selected, the AMI BIOS automatically detects the presence of IDE or SATA devices and displays the following items.

**SATA Port0–SATA Port5:** The AMI BIOS displays the status of each SATA port as detected by the BIOS.

### SATA Mode

Use this feature to configure SATA mode for a selected SATA port. The options are Disabled, IDE Mode, **AHCI Mode** and RAID Mode. The following are displayed depending on your selection:

#### IDE Mode

The following items are displayed when IDE Mode is selected:

##### **Serial-ATA (SATA) Controller 0 and Serial-ATA (SATA) Controller 1**

Use this feature to activate or deactivate the SATA controller and to set SATA modes. The options are Disabled, Enhanced, and Compatible. The default for SATA Controller 0 is **Compatible**. The default of SATA Controller 1 is **Enhanced**.

#### AHCI Mode

The following items are displayed when the AHCI Mode is selected.

##### **Aggressive Link Power Management**

When this feature is set to Enabled, the SATA AHCI controller manages the power usage of the SATA link. The controller will put the link in a low power mode during an extended period of I/O inactivity, and will return the link to an active state when I/O activity resumes. The options are **Enabled** and Disabled.

##### **Port 0–5 Hot Plug**

Select Enabled to enable hot-plug support for a particular port, which will allow the user to change a hardware component or device without shutting down the system. The options are **Enabled** and Disabled.

##### **Port 0–5 Staggered Spin-up**

Select Enabled to enable Staggered Spin-up support for a port specified by the user to prevent excessive power consumption caused by multiple HDDs spinning-up simultaneously. The options are Enabled and **Disabled**.

#### RAID Mode

The following items are displayed when RAID Mode is selected:

### SATA RAID Option ROM/UEFI Driver

Select Enabled to boot the system from a SATA RAID device or a UEFI (Unified Extensible Firmware Interface) device. The options are **Enabled** or Disabled.

### Port 0-5 Hot Plug

Select Enabled to enable hot-plug support for a port specified by the user. The options are **Enabled** and Disabled.

## ► PCIe/PCI/PnP Configuration

This submenu allows the user to configure the following PCIe/PCI/PnP settings.

### Launch Storage OpROM Policy

This feature selects the Storage Option ROM to be used to bootup the system from a storage device when there are multiple Storage Option ROMs available. The options are UEFI Only and **Legacy Only**.

### PCI Latency Timer

Use this feature to set the latency timer of each PCI device installed on a PCI bus. Select 64 to set the PCI latency to 64 PCI clock cycles. The options are 32 PCI Bus Clock, **64 PCI Bus Clock**, 96 PCI Bus Clock, 128 PCI Bus Clock, 160 PCI Bus Clock, 192 PCI Bus Clock, 224 PCI Bus Clock, and 248 PCI Bus Clock.

### PERR# Generation

Select Enabled to allow a PCI device to generate a PERR number for a PCI Bus Signal Error Event. The options are Enabled and **Disabled**.

### SERR# Generation

Select Enabled to allow a PCI device to generate a SERR number for a PCI Bus Signal Error Event. The options are Enabled and **Disabled**.

### Maximum Payload

Select Auto to allow the system BIOS to automatically set the maximum payload value for a PCI-E device to enhance system performance. The options are **Auto**, 128 Bytes and 256 Bytes.

### Maximum Read Request

Select Auto to allow the system BIOS to automatically set the maximum read request size for a PCI-E device to enhance system performance. The options are **Auto**, 128 Bytes, 256 Bytes, 512 Bytes, 1024 Bytes, 2048 Bytes, and 4096 Bytes.

### ASPM Support

This feature allows the user to set the Active State Power Management (ASPM) level for a PCI-E device. Select Auto to allow the system BIOS to automatically set the ASPM level for the system. Select Disabled to disable ASPM support. The options are **Disabled** and Auto.

**Warning:** Enabling ASPM support may cause some PCI-E devices to fail!

### Above 4G Decoding (Available if the system supports 64-bit PCI decoding)

Select Enabled to decode a PCI device that supports 64-bit in the space above 4G Address. The options are Enabled and **Disabled**.

### PCH Slot 2 PCI-E 2.0 x1 OPROM, PCH Slot 3 PCI-E 2.0 x4 (in x8) OPROM, CPU1 Slot 4 PCI-E 3.0 x8 OPROM, CPU1 Slot 6 PCI-E 3.0 x8 OPROM

Select Enabled to enable Option ROM support to boot the computer using a device installed on a slot specified above. The options are **Enabled** and Disabled.

### Onboard LAN Option ROM Select

Select iSCSI to use the iSCSI Option ROM to boot the computer using a network device. Select PXE (Preboot Execution Environment) to use an PXE Option ROM to boot the computer using a network device. The options are iSCSI and **PXE**.

### Load Onboard LAN1 Option ROM/Load Onboard LAN2 Option ROM

Select Enabled to enable the onboard LAN1 Option ROM/LAN2 Option ROM. This is to boot the computer using a network device. The default setting for LAN1 Option ROM is **Enabled**, and the default setting for LAN2 Option ROM is **Disabled**.

### Load Onboard SAS Option ROM

Select Enabled to enable the onboard SAS Option ROM. This is to boot the computer using a SAS device. The options are **Enabled** and Disabled.

### VGA Priority

This feature allows the user to select the graphics adapter to be used as the primary boot device. The options are **Onboard**, and Offboard.

### Network Stack

When this featurer is set to Enabled, both PXE (Preboot Execution Environment) and UEFI (Unified Extensible Firmware Interface) will be enabled for network stack support. The options are Enabled and **Disabled**.

---

## ► Super IO Configuration

### Super IO Chip

Displays the Super IO chip type.

## ► COM 1 Configuration

### Serial Port

Select Enabled to enable a serial port specified by the user. The options are **Enabled** and Disabled.

### Device Settings

This item displays the settings of Serial Port 1.

### Change Settings

This option specifies the base I/O port address and the Interrupt Request address of COM Port 1. The options are **Auto**, IO=3F8h; IRQ=4; IO=3F8h; IRQ=3; IO=2F8h; IRQ=3; IO=3E8h; IRQ=5; IO=2E8h; IRQ=7; IO=3F8h; IRQ=3, 4, 5, 6, 7, 10, 11, 12; IO=2F8h; IRQ=3, 4, 5, 6, 7, 10, 11, 12; IO=3E8h; IRQ=3, 4, 5, 6, 7, 10, 11, 12; and IO=2E8h; IRQ=3, 4, 5, 6, 7, 10, 11, 12.

### Device Mode

Use this feature to select the desired mode for a serial port specified. The options are **Normal** and High Speed.

## ► SOL (Serial\_Over\_LAN) Configuration

### SOL Serial Port

Select Enabled to enable a serial port (Serial Port 2) specified by the user for SOL use. The options are **Enabled** and Disabled.

### Device Settings

This item displays the settings of Serial Port 2.

### SOL (Serial\_Over\_LAN) Change Settings

This option specifies the base I/O port address and the Interrupt Request address of Serial Port 2. The options are **Auto**, IO=3F8h; IRQ=4; IO=3F8h; IRQ=3; IO=2F8h; IRQ=3; IO=3E8h; IRQ=5; IO=2E8h; IRQ=7; IO=3F8h; IRQ=3, 4, 5, 6, 7, 10, 11, 12; IO=2F8h; IRQ=3, 4, 5, 6, 7, 10, 11, 12; IO=3E8h; IRQ=3, 4, 5, 6, 7, 10, 11, 12; and IO=2E8h; IRQ=3, 4, 5, 6, 7, 10, 11, 12.

### **SOL (Serial\_Over\_LAN) Device Mode**

Use this feature to select the desired mode for the SOL port. The options are **Normal** and High Speed.

### **Serial Port 2 Attribute**

Use this feature to select the attribute for serial port 2. The options are **SOL** (Serial\_On\_LAN), and COM.

#### **Device Mode**

Use this feature to select the desired mode for a serial port specified. The options are **Normal** and High Speed.

## **►Serial Port Console Redirection**

These submenus allow the user to configure the following Console Redirection settings for a COM Port 1 or COM Port 2 as specified by the user.

### **COM 1/SOL (Serial-Over-LAN)**

#### **COM1/SOL Console Redirection**

Select Enabled to use COM Port1 or SOL Port for Console Redirection. The options are **Enabled** and Disabled. If this feature is set to enabled, the following items will display.

## **►Console Redirection Settings**

This feature allows the user to specify how the host computer will exchange data with the client computer, which is the remote computer used by the user.

### **Terminal Type**

This feature allows the user to select the target terminal emulation type for Console Redirection. Select VT100 to use the ASCII character set. Select VT100+ to add color and function key support. Select ANSI to use the extended ASCII character set. Select VT-UTF8 to use UTF8 encoding to map Unicode characters into one or more bytes. The options are VT100, **VT100+**, VT-UTF8, and ANSI.

### **Bits Per Second**

This item sets the transmission speed for a serial port used in Console Redirection. Make sure that the same speed is used in the host computer and the client computer. A lower transmission speed may be required for long and busy lines. The options are 9600, 19200, 38400, 57600, and **115200** (bits per second).

**Data Bits**

Use this feature to set the data transmission size for Console Redirection. The options are 7 and **8** (Bits).

**Parity**

A parity bit can be sent along with regular data bits to detect data transmission errors. Select Even if the parity bit is set to 0, and the number of 1's in data bits is even. Select Odd if the parity bit is set to 0, and the number of 1's in data bits is odd. Select None if you do not want to send a parity bit with your data bits in transmission. Select Mark to add mark as a parity bit to be sent along with the data bits. Select Space to add a Space as a parity bit to be sent with your data bits. The options are **None**, Even, Odd, Mark, and Space.

**Stop Bits**

A stop bit indicates the end of a serial data packet. Select 1 Stop Bit for standard serial data communication. Select 2 Stop Bits if slower devices are used. The options are **1** and 2.

**Flow Control**

This feature allows the user to set the flow control for Console Redirection to prevent data loss caused by buffer overflow. Send a "Stop" signal to stop sending data when the receiving buffer is full. Send a "Start" signal to start sending data when the receiving buffer is empty. The options are **None** and Hardware RTS/CTS.

**VT-UTF8 Combo Key Support**

Select Enabled to enable VT-UTF8 Combination Key support for ANSI/VT100 terminals. The options are **Enabled** and Disabled.

**Recorder Mode**

Select Enabled to capture the data displayed on a terminal and send it as text messages to a remote server. The options are **Disabled** and Enabled.

**Resolution 100x31**

Select Enabled for extended-terminal resolution support. The options are Disabled and **Enabled**.

**Legacy OS Redirection**

Use this feature to select the number of rows and columns used in Console Redirection for legacy OS support. The options are 80x24 and **80x25**.

### Putty Keypad

Use this feature to select function key and keypad setting on Putty. The options are **VT100**, LINUX, XTERMR6, SCO, ESCN, and VT400.

### Redirection After BIOS POST

If **Always Enabled** is selected, Legacy Console Redirection will be enabled for Legacy OS after BIOS POST (Power-On Self Test) is completed. The options are **Always Enabled**, and BootLoader.

### Serial Port for Out-of-Band Management/Windows Emergency Management Services (EMS)

This item allows the user to configure Console Redirection settings to support Out-of-Band Serial Port management.

### Console Redirection

Select Enabled to use a COM Port selected by the user for Console Redirection. The options are Enabled and **Disabled**.

## ► Console Redirection Settings

This feature allows the user to specify how the host computer will exchange data with the client computer, which is the remote computer used by the user.

### Out-of-Band-Mgmt (Management) Port

Use this feature to select the port to be used for out-of-band management. The options are **COM1** and COM2

### Terminal Type

This feature allows the user to select the target terminal emulation type for Console Redirection. Select VT100 to use the ASCII character set. Select VT100+ to add color and function key support. Select ANSI to use the extended ASCII character set. Select VT-UTF8 to use UTF8 encoding to map Unicode characters into one or more bytes. The options are ANSI, VT100, **VT100+**, and VT-UTF8.

### Bits Per Second

This item sets the transmission speed for a serial port used in Console Redirection. Make sure that the same speed is used in the host computer and the client computer. A lower transmission speed may be required for long and busy lines. The options are 9600, 19200, 57600, and **115200** (bits per second).



### Flow Control

This feature allows the user to set the flow control for Console Redirection to prevent data loss caused by buffer overflow. Send a "Stop" signal to stop sending data when the receiving buffer is full. Send a "Start" signal to start sending data when the receiving buffer is empty. The options are **None**, Hardware RTS/CTS, and Software Xon/Xoff.

### Data Bits

Use this feature to set the data transmission size for Console Redirection. The options are 7 and 8 (Bits).

### Parity

A parity bit can be sent along with regular data bits to detect data transmission errors. Select Even if the parity bit is set to 0, and the number of 1's in data bits is even. Select Odd if the parity bit is set to 0, and the number of 1's in data bits is odd. Select None if you do not want to send a parity bit with your data bits in transmission. Select Mark to add mark as a parity bit to be sent along with the data bits. Select Space to add a Space as a parity bit to be sent with your data bits. The options are **None**, Even, Odd, Mark, and Space.

### Stop Bits

A stop bit indicates the end of a serial data packet. Select 1 Stop Bit for standard serial data communication. Select 2 Stop Bits if slower devices are used. The options are 1 and 2.

## ► ACPI Settings

Use this feature to configure Advanced Configuration and Power Interface (ACPI) power management settings for your system.

### ACPI Sleep State

Use this feature to select the ACPI State when the system is in sleep mode. Select S1 (CPU Stop Clock) to erase all CPU caches and stop executing instructions. Power to the CPU(s) and RAM is maintained, but RAM is refreshed. Select Suspend to use power-reduced mode. Power will only be supplied to limited components (such as RAMs) to maintain the most critical functions of the system. The options are **S1 (CPU Stop Clock)** and Suspend Disabled.

### NUMA (NON-Uniform Memory Access)

This feature enables the Non-Uniform Memory Access ACPI support. The options are **Enabled** and Disabled.

### High Precision Event Timer

Select Enabled to activate the High Precision Event Timer (HPET) that produces periodic interrupts at a much higher frequency than a Real-time Clock (RTC) does in synchronizing multimedia streams, providing smooth playback, reducing the dependency on other timestamp calculation devices, such as an x86 RDTSC Instruction embedded in the CPU. The High Performance Event Timer is used to replace the 8254 Programmable Interval Timer. The options are **Enabled** and Disabled.

### ► Intel ME (Management Engine) Subsystem

This feature displays the following ME Subsystem Configuration settings.

- **ME BIOS Interface Version**
- **ME Version**

### ► Trusted Computing (Available if a TPM device is installed)

#### Configuration

##### TPM Support

Select Enabled on this item and enable the TPM jumper on the serverboard to allow TPM support to improve data integrity and network security. The options are Enabled and **Disabled**.

**Current Status Information:** This item displays the information regarding the current TPM status.

##### TPM Enable Status

If a security device is detected by the BIOS, this item displays the status of TPM Support to indicate if TPM is currently enabled or disabled.

##### TPM Active Status

If a security device is detected by the BIOS, this item displays the status of TPM Support to indicate if TPM is currently active or deactivated.

##### TPM Owner Status

If a security device is detected by the BIOS, this item displays the status of TPM Ownership.

### ► Intel TXT(LT-SX) Configuration

This feature indicates if the following hardware components support the Intel TXT (Trusted Execution Technology), which helps protect against software-based attacks and ensures protection, confidentiality and integrity of data stored or created on the system.

- **CPU/Chipset TXT Feature** - Displays status of TXT Feature support.
- **TXT Support** - Indicates if TXT support is enabled or disabled. The default setting is **Disabled**.
- **Intel TXT Dependencies** - Displays a list of features that must be supported (and enabled) before Intel TXT(LT-SX) configuration can be enabled.

## 7-4 Event Logs

Use this menu to configure Event Log settings.

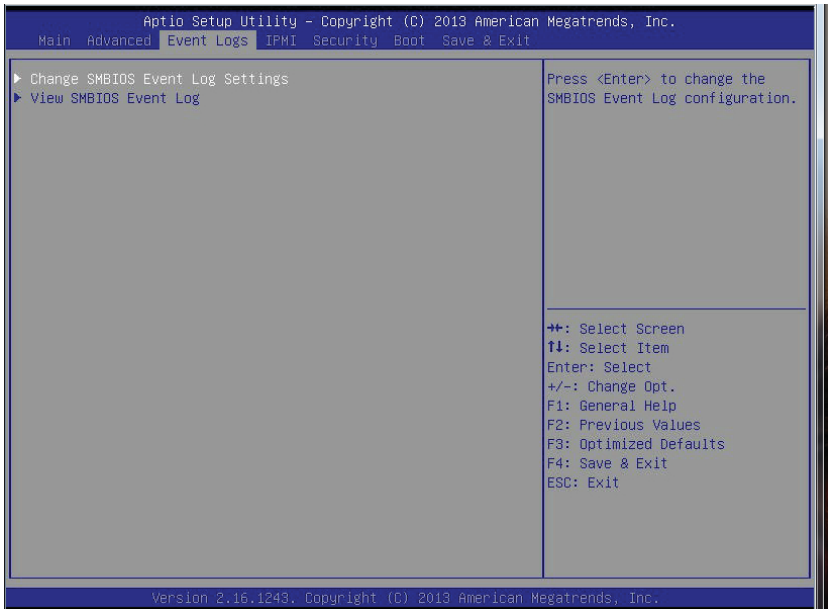

### ► Change Smbios Event Log Settings

#### Enabling/Disabling Options

#### Smbios Event Log

Change this item to enable or disable all features of the Smbios Event Logging during boot. The options are **Enabled** and Disabled.

### **Runtime Error Logging Support**

Change this item to enable or disable runtime error logging. The options are **Enabled** and **Disabled**.

### **Memory Correction Error Threshold**

Change this item to define the system's memory correction error threshold. Directly enter a numeric value. The default value is **10**.

### **PCI Error Logging Support**

Change this item to enable or disable runtime error logging. The options are **Enabled** and **Disabled**.

### **Erasing Settings**

#### **Erase Event Log**

This option erases all logged events. The options are **No**, **Yes**, **Next reset**, and **Yes, Every reset**.

#### **When Log is Full**

This option automatically clears the Event Log memory of all messages when it is full. The options are **Do Nothing** and **Erase Immediately**.

#### **Log System Boot Event**

This option toggles the System Boot Event logging to enabled or disabled. The options are **Disabled** and **Enabled**.

### **MECI**

The Multiple Event Count Increment (MECI) counter counts the number of occurrences a duplicate event must happen before the MECI counter is incremented. This is a numeric value ranging from 1 to 255. The default value is **1**.

### **METW**

The Multiple Event Time Window (METW) defines number of minutes must pass between duplicate log events before MECI is incremented. This is in minutes, from 0 to 99. The default value is **60**.

### **View Smbios Event Log**

This feature displays the contents of the SmbIOS Event Log.

## 7-5 IPMI

Use this menu to configure Intelligent Platform Management Interface (IPMI) settings.

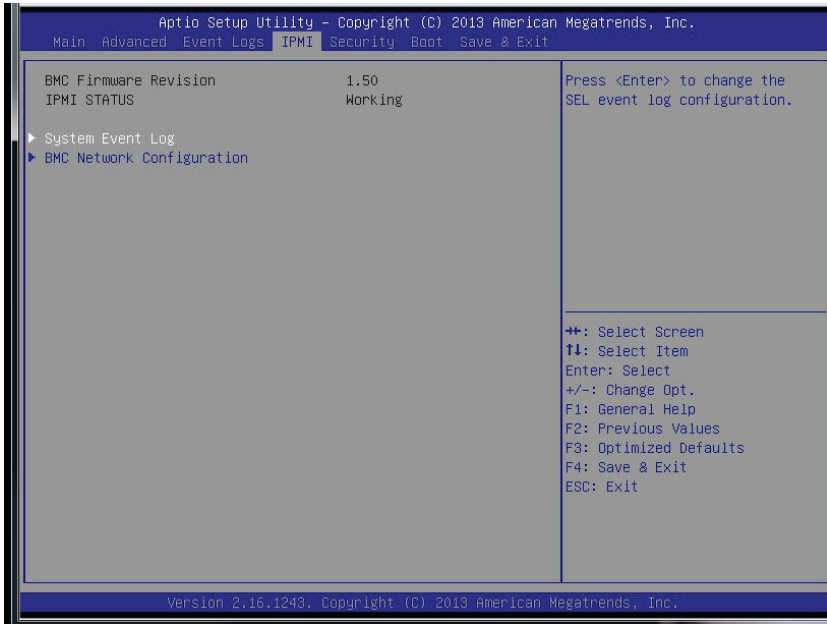

### ► System Event Log

#### Enabling/Disabling Options

##### SEL Components

Select Enabled for all system event logging at bootup. The options are **Enabled** and Disabled.

#### Erasing Settings

##### Erase SEL

Select 'Yes, On next reset' to erase all system event logs upon next system reboot. Select 'Yes, On every reset' to erase all system event logs upon each system reboot. Select No to keep all system event logs after each system reboot. The options are **No**, Yes, On next reset, and Yes, On every reset.

### **When SEL is Full**

This feature allows the user to decide what the BIOS should do when the system event log is full. Select Erase Immediately to erase all events in the log when the system event log is full. The options are **Do Nothing** and Erase Immediately.

## **►BMC Network Configuration**

**LAN Channel 1:** This feature allows the user to configure the settings for LAN Channel 1.

**IPMI LAN Selection:** This feature displays the available IPMI LAN modes.

**IPMI Network Link Status:** This feature displays the IPMI Network Link status.

### **Update IPMI LAN Configuration**

This feature allows the user to decide if the BIOS should configure the IPMI setting at next system boot. The options are **No** and Yes. If the option is set to Yes, the user is allowed to configure the IPMI settings at next system boot:

### **Configuration Address Source**

This feature allows the user to select the source of the IP address for this computer. If Static is selected, you will need to know the IP address of this computer and enter it to the system manually in the field below. The options are Static and **DHCP**.

### **Station IP Address**

This item displays the Station IP address for this computer. This should be in decimal and in dotted quad form (i.e., 192.168.10.253).

### **Subnet Mask**

This item displays the sub-network that this computer belongs to. The value of each three-digit number separated by dots should not exceed 255.

### **Station MAC Address**

This item displays the Station Mac address for this computer. Mac addresses are 6 two-digit hexadecimal numbers.

### **Gateway IP Address**

This item displays the Gateway IP address for this computer. This should be in decimal and in dotted quad form (i.e., 192.168.10.253).

## 7-6 Boot

This menu allows the user to configure the following boot settings for the system.

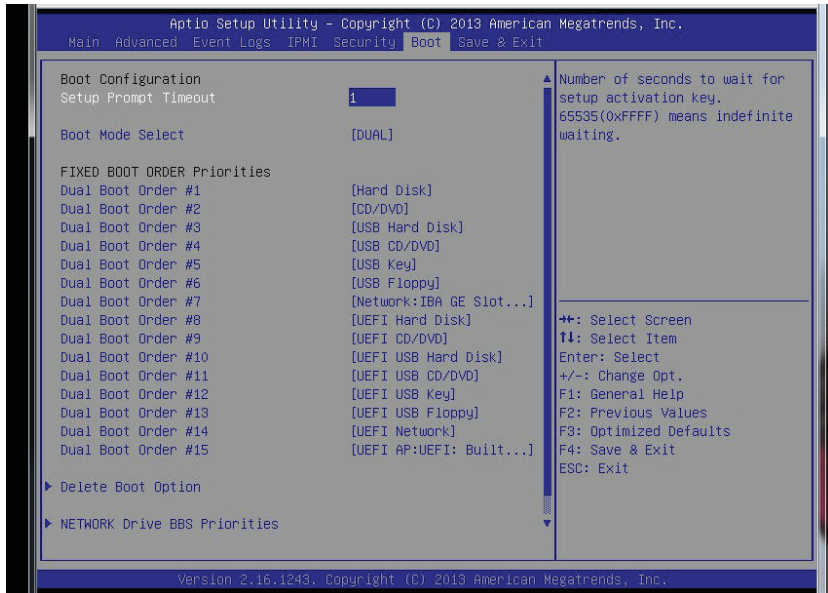

### Set Boot Priorities

#### 1st Boot Device/2nd Boot Device/3rd Boot Device/4th Boot Device/5th Boot Device/6th Boot Device

Use this feature to specify the sequence of boot priority for a device specified by the user.

#### ▶ Add New Boot Option

This feature allows the user to configure the following settings when adding a new device to the boot priority list.

##### Add Boot Option

##### Path for Boot Option

##### Boot Option File Path

##### Create

#### ▶ Delete Boot Option

This feature allows the user to select a boot device to delete from the boot priority list.

► **USB Hard Disk Drive BBS Priorities**

This submenu allows the user to specify the boot priority sequence of a USB hard drive.

1st Device

► **Network Device BBS Priorities**

This submenu allows the user to specify the boot priority sequence of a network device.

1st Device

► **UEFI Boot Device BBS Priorities**

This submenu allows the user to specify the boot priority sequence of a UEFI bootable device.

1st Device

## 7-7 Security

This menu allows the user to configure the security settings for the system.

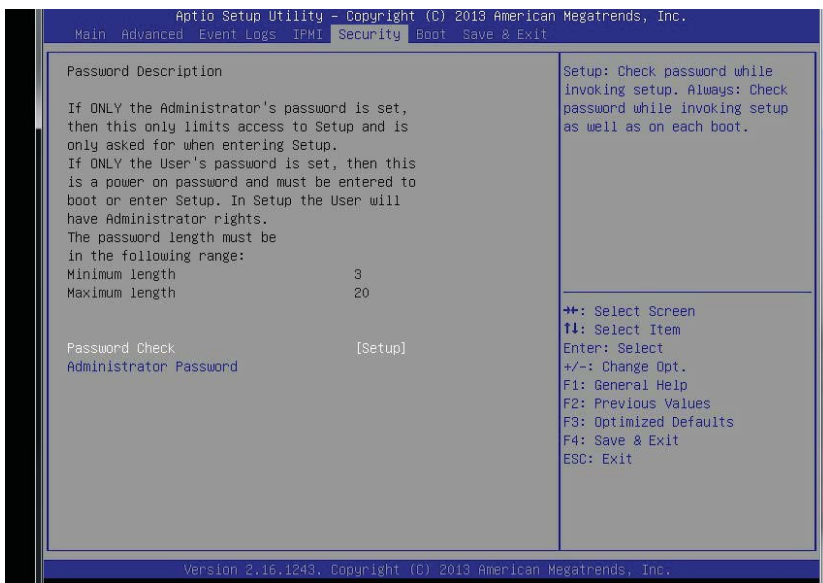



## Password Check

This item allows you to decide when the system should check for a password after it has been entered. Select Setup for the system to prompt for a password before the user enters the BIOS Setup utility. Select Always for the system to prompt for a password upon each system boot and before the user enters the Setup utility. The options are **Setup** and Always.

## Administrator Password

Use this feature to set the Administrator Password which is required to enter the BIOS setup utility. The length of the password should be from 3 characters to 20 characters long.

## 7-8 Save & Exit

This submenu allows the user to configure the Save and Exit settings for the system.

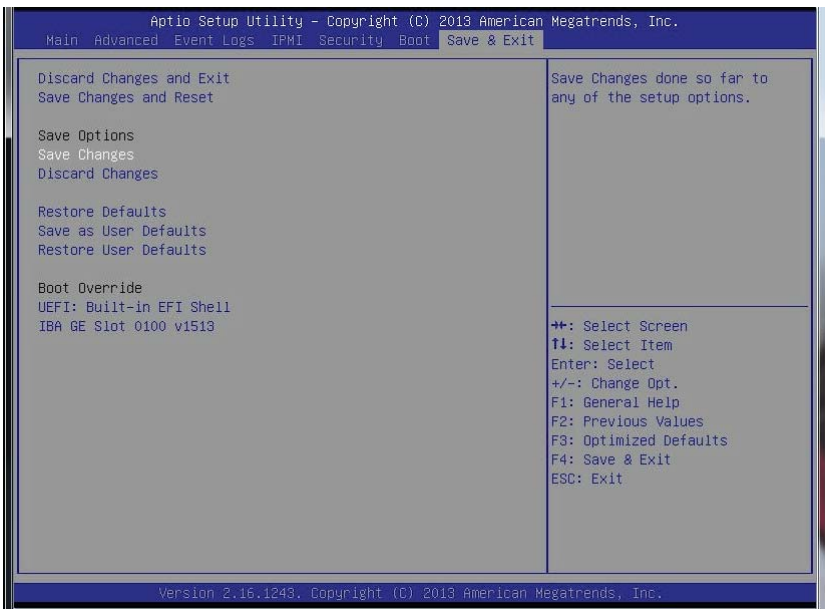

### Discard Changes and Exit

Select this option to quit the BIOS Setup without making any permanent changes to the system configuration, and reboot the computer. Select Discard Changes and Exit, and press <Enter>. When the dialog box appears, asking you if you want to exit the BIOS setup without saving, select **Yes** to quit BIOS without saving the changes, or select No to quit the BIOS and save changes.

### **Save Changes and Reset**

When you have completed the system configuration changes, select this option to save the changes and reboot the computer so that the new system configuration settings can take effect. Select **Save Changes and Exit**, and press <Enter>. When the dialog box appears, asking you if you want to exit the BIOS setup without saving, select **Yes** to quit BIOS without saving the changes, or select **No** to quit the BIOS and save changes.

### **Save Options**

#### **Save Changes**

Select this option and press <Enter> to save all changes you've done so far and return to the AMI BIOS utility Program. When the dialog box appears, asking you if you want to save configuration, select **Yes** to save the changes, or select **No** to return to the BIOS without making changes.

#### **Discard Changes**

Select this feature and press <Enter> to discard all the changes and return to the BIOS setup. When the dialog box appears, asking you if you want to load previous values, select **Yes** to load the values previous saved, or select **No** to keep the changes you've made so far.

#### **Restore Optimized Defaults**

Select this feature and press <Enter> to load the optimized default settings that help optimize system performance. When the dialog box appears, asking you if you want to load optimized defaults, select **Yes** to load the optimized default settings, or select **No** to abandon optimized defaults.

#### **Save as User Defaults**

Select this feature and press <Enter> to save the current settings as the user's defaults. When the dialog box appears, asking you if you want to save values as user's defaults, select **Yes** to save the current values as user's default settings, or select **No** to keep the defaults previously saved as the user's defaults.

#### **Restore User Defaults**

Select this feature and press <Enter> to load the user's defaults previously saved in the system. When the dialog box appears, asking you if you want to restore user's defaults, select **Yes** to restore the user's defaults previously saved in the system, or select **No** to abandon the user's defaults that were previously saved.

**Boot Override**

This feature allows the user to override the Boot Option Priorities setting in the Boot menu, and instead immediately boot the system with one of the listed devices. This is a one-time override.

**Notes**

## Appendix A

### BIOS Error Beep Codes

During the POST (Power-On Self-Test) routines, which are performed each time the system is powered on, errors may occur.

**Non-fatal errors** are those which, in most cases, allow the system to continue the boot-up process. The error messages normally appear on the screen.

**Fatal errors** are those which will not allow the system to continue the boot-up procedure. If a fatal error occurs, you should consult with your system manufacturer for possible repairs.

These fatal errors are usually communicated through a series of audible beeps. The numbers on the fatal error list (on the following page) correspond to the number of beeps for the corresponding error. All errors listed, with the exception of Beep Code 8, are fatal errors.

#### A-1 AMIBIOS Error Beep Codes

Beep Code	Error Message	Description
1 beep	Refresh	Circuits have been reset (Ready to power up)
5 short beeps and 1 long beep	Memory error	No memory detected in the system
5 beeps	No Con-In or No Con-Out devices	Con-In: USB or PS/2 keyboard, PCI or Serial Console Redirection, IPMI KVM or SOL Con-Out: Video Controller, PCI or Serial Console Redirection, IPMI SOL
1 beep per device	Refresh	1 beep for each USB device
<b>X9 IPMI Error Codes</b>		
1 continuous beep	System overheat	System overheat

**Notes**

## Appendix B

# System Specifications

### Processors

Single or dual Intel® Xeon E5-2600v3 Series processors

**Note:** If using only a single processor then slots SXB1B and SXB2 (lower left) will NOT be functional for expansion cards.

**Note:** Please refer to our web site for a complete listing of supported processors.

### Chipset

Intel PCH-C612 chipset

### BIOS

128 MB SPI AMI BIOS® SM Flash UEFI BIOS

### Memory Capacity

Sixteen (16) DIMM slots that can support up to 1024 GB of ECC RDIMM or LRDIMM DDR4 2133/1866/1600/1333 MHz speed memory in 1 GB, 2 GB, 4 GB, 8 GB, 16 GB, 32 GB and 64 GB size @ 1.2V voltage.

**Note:** see Section 5-6 for details.

### Drive Bays

Contains four (4) SATA-3 hot-swap drive bays to house up to four SATA drives

### Expansion Slots

Two full-height, full-length PCI-E 3.0 x16 cards with use of riser card (included)

### Serverboard

X10DRW-i(T)

Dimensions: (LxW) 13.05" (L) x 12.80" (W) (331.47 mm x 325.12 mm))

### Chassis

SC815TQ-R700WB

Form Factor: 1U rackmount

Dimensions: (WxHxD) 17.2 x 1.7 x 23.5 in. (437 x 43 x 597 mm)

## Weight

Gross (Bare Bone): 25 lbs (11.3 kg)

## System Cooling

Contains up to five (5) 4-cm heavy-duty counter-rotating easy swap fans

**Note:** The system cooling fans are NOT redundant, hot-plug.

## Power Supply Input Requirements

AC Input Voltage: 100V - 240V AC auto-range

Rated Input Current:

700W 100-140Vac: 8-6A, 50-60Hz

750W 200-240Vac: 4.3-3.8A, 50-60Hz

## Power Supply Output

Rated Output Power: 700/750 Watt (Part# PWS-706P-1R)

Rated Output Voltages: +12V (700W: 58A @ 90V-140VAC, 750W: 62A @ 180-264VAC), +5Vsb (3A)

## Operating Environment

Operating Temperature: 0° to 50° C (32° to 122° F)

Non-operating Temperature: -40° to 60° C (-40° to 140° F)

Operating Relative Humidity: 8% to 90% (non-condensing)

Non-operating Relative Humidity: 5% to 95% (non-condensing)

**Note:** The system power supplies are redundant, hot-plug.

## Regulatory Compliance

Electromagnetic Emissions: FCC Class A, EN 55022 Class A, EN 61000-3-2/-3-3, CISPR 22 Class A

Electromagnetic Immunity: EN 55024/CISPR 24, (EN 61000-4-2, EN 61000-4-3, EN 61000-4-4, EN 61000-4-5, EN 61000-4-6, EN 61000-4-8, EN 61000-4-11)

Safety: CSA/EN/IEC/UL 60950-1 Compliant, UL or CSA Listed (USA and Canada), CE Marking (Europe)

California Best Management Practices Regulations for Perchlorate Materials: This Perchlorate warning applies only to products containing CR (Manganese Dioxide) Lithium coin cells. "Perchlorate Material-special handling may apply. See [www.dtsc.ca.gov/hazardouswaste/perchlorate](http://www.dtsc.ca.gov/hazardouswaste/perchlorate)"



## Notes

(continued from front)

The products sold by Supermicro are not intended for and will not be used in life support systems, medical equipment, nuclear facilities or systems, aircraft, aircraft devices, aircraft/emergency communication devices or other critical systems whose failure to perform be reasonably expected to result in significant injury or loss of life or catastrophic property damage. Accordingly, Supermicro disclaims any and all liability, and should buyer use or sell such products for use in such ultra-hazardous applications, it does so entirely at its own risk. Furthermore, buyer agrees to fully indemnify, defend and hold Supermicro harmless for and against any and all claims, demands, actions, litigation, and proceedings of any kind arising out of or related to such ultra-hazardous use or sale.